

(No Model.)

2 Sheets—Sheet 1.

L. DUNN.

SAFETY DEVICE FOR POINT SWITCHES.

No. 524,273.

Patented Aug. 7, 1894.

Fig. 1.

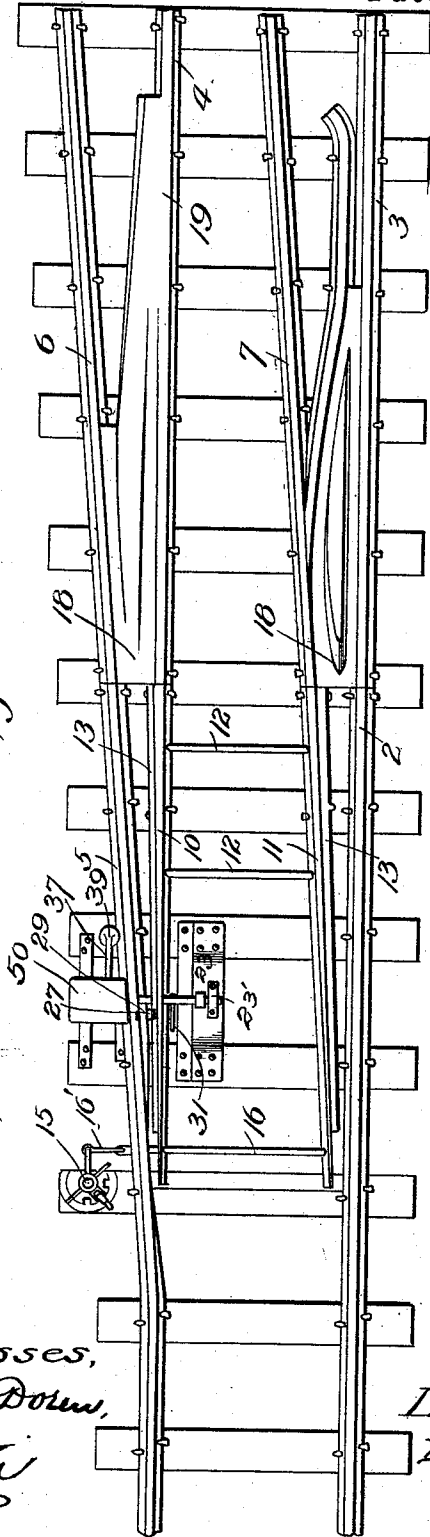
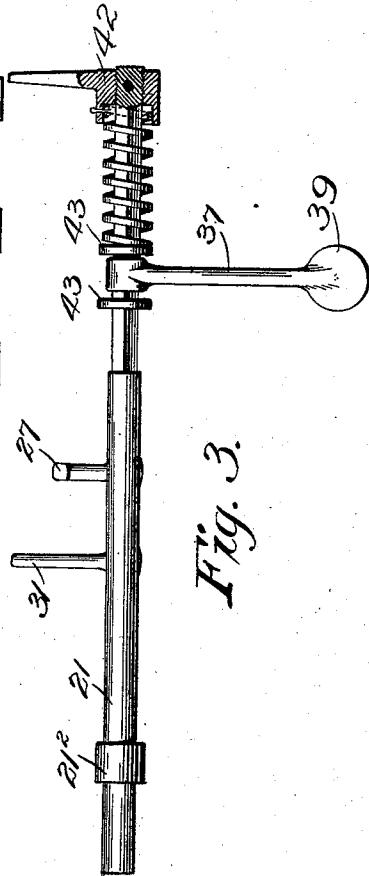

Fig. 3.



Witnesses,
C. E. Van Doren,
J. H. Dixon

Inventor,
Louis Dunn.

By *Paul H. Atwoley*
 Att'ys.

(No Model.)

2 Sheets—Sheet 2.

L. DUNN.

SAFETY DEVICE FOR POINT SWITCHES.

No. 524,273.

Patented Aug. 7, 1894.

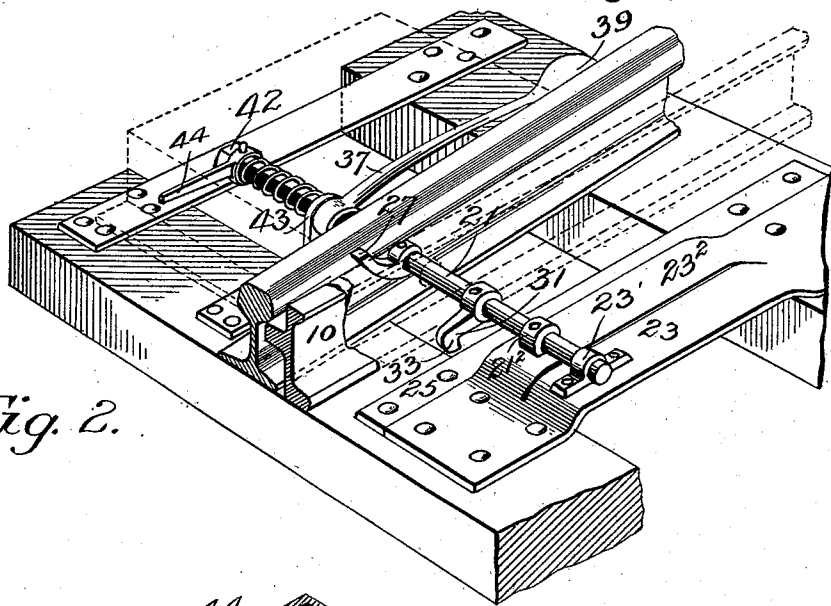

Fig. 2.

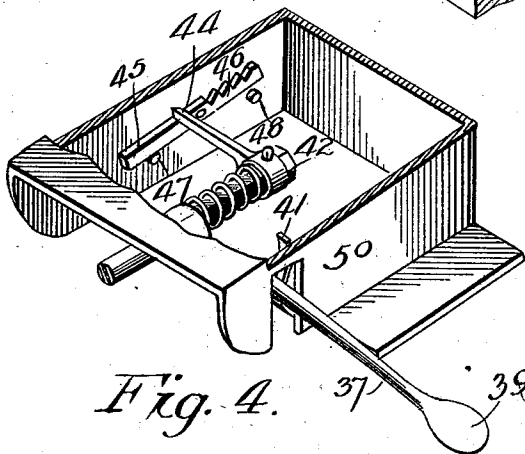

Fig. 4. 37 39

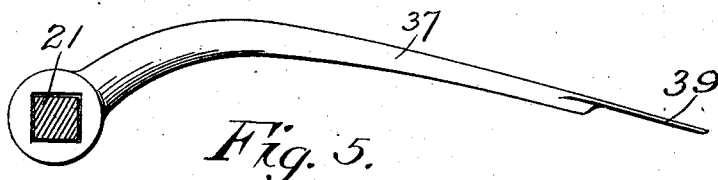

Fig. 5.

Witnesses
 C. E. Van Dorn.
 J. S. Lyon

Inventor.
 Louis Dunn.
 By Paul & Hawley
 Att'ys.

UNITED STATES PATENT OFFICE.

LOUIS DUNN, OF MINNEAPOLIS, MINNESOTA.

SAFETY DEVICE FOR POINT-SWITCHES.

SPECIFICATION forming part of Letters Patent No. 524,273, dated August 7, 1894.

Application filed September 2, 1893; Serial No. 484,645. (No model.)

To all whom it may concern:

Be it known that I, LOUIS DUNN, of the city of Minneapolis, county of Hennepin, State of Minnesota, have invented certain new and useful Improvements in Safety Devices for Point-Switches, of which the following is a specification.

The object of this invention is to provide a safety device to be used in connection with a point or split switch so as to prevent derailment of trains running toward the points of the switch when the switch is in a neutral or partially open position; further to provide means for preventing the train from running onto the side-track even in case the switch is left partly open; and further, to provide means whereby the switch will be positively closed by a train passing from the points thereof.

It sometimes occurs in the use of point or split switches, that the switch rod breaks or the points become fouled by ice, snow or the lodging of a piece of metal or some other substance between one of the points and the stock rails, so that the switch is not fully thrown to connect with the rails of either track; and sometimes by design the switches are partially opened or set at a neutral point by persons intending to wreck the trains.

By the use of this invention I make it impossible to throw the train from the tracks by having the points fouled or set in a neutral position; and to this end my invention consists in means arranged in connection with the points, of a switch for supporting and guiding the wheels of a train passing toward a partially opened switch so as to direct the wheels back onto the main track.

The invention consists generally in means provided in connection with the points for supporting the flanges of the wheels so as to guide the wheels into the spaces between the rails of the main line and the rails of the side track, at which point I also provide means for directing the wheels back onto the main track.

The invention further consists in means for locking the points in a neutral position at the instant a truck passes upon the same, thereby preventing the points from being thrown into position to run the train onto the side track;

and further the invention consists in automatic means for locking the points against the main rail to maintain the straight track.

The invention further consists in the constructions and combinations hereinafter described and particularly pointed out in the claims, and will be more readily understood by reference to the accompanying drawings, in which—

Figure 1 is a plan view showing a point switch having my invention applied thereto. Fig. 2 is an enlarged perspective detail showing the point rail, the diverging end of the main rail and the locking mechanism connected therewith. Fig. 3 is an enlarged detail view of the locking shaft. Fig. 4 is a perspective detail showing the box, which is removed from Fig. 1, and also showing the parts therein. Fig. 5 is a detail showing the lever connected with the shaft.

In the patent issued to me, on the 18th of June, 1889, numbered 405,350, is described and claimed a safety device to be used in connection with a stub switch, and in that patent is shown and described means arranged between the stationary rails of the main and side tracks to receive a train passing from the switch or movable rails when the switch is only partially open, or is in a position in which its rails do not connect with the rails of either the main or the side track.

In my present invention I provide means for preventing the derailment of a train, in connection with a split or point switch, and the means that I employ between the fixed rails of the main and side track for the purpose of receiving the flanges of the wheels and guiding the wheels back onto the main track, is substantially the same in this application as that shown and described in said patent issued to me, as above specified; but it will be understood that any suitable means or device may be used between these rails for this purpose, as my present invention relates to the means used in connection with the movable points for guiding the wheels into the spaces between the rails of the main and the side track.

As shown in the drawings, 3 and 4 represent the rails of the main track, and 7 and 6

the corresponding rails of the side track, these rails being fixed in the usual manner and converging past each other in the usual way.

2 and 5 represent the outer or stock rails, one of which is in line with the outer rail of the main track, and the other being preferably bent and forming the continuation of the outer rail of the side track.

10 and 11 represent the points arranged in the usual manner and connected together by the usual tie-bar 12. The points are also provided with the head rod 16 to which is joined the connecting rod 16', which is connected to the usual stand 15. It will be seen that with the points as generally constructed, when the switch is partially open or in the neutral position, (shown in Fig. 2,) a train passing toward the points will not be directed onto either the main track or the side track, but the flanges of the wheels passing outside of both of the points will drop down between the points and the stock rails and the train will thus be derailed. There are many ways in which the points may get into this neutral position; either the head rod or the connecting rod may become broken and the points become accidentally displaced, or some foreign substance such as a broken bolt or other piece of metal, or a piece of ice may get between one of the points and the stock rail and thus prevent the switch from being completely thrown; or the switch may be left partially open by design by persons intending to derail the trains. In any event, where a point or split switch is used, whenever the switch is left in this position and a train passes along the track toward the points it will inevitably be thrown from the track. For the purpose of preventing this I arrange the points so that the distance between their outer sides is the same as the distance between the inner surfaces of the wheels; and I also provide a filling piece or strip 13 that is either integrally or separably arranged upon the outer side of each point to receive and support the wheel flanges, as shown in Fig. 1; then whenever the points are in such position that the wheels would pass between the points and the stock rails, the outer surfaces of the points will act as guides for the back or inner surfaces of the wheels, and the flanges of the wheels will roll upon the tops of the fillings 13. In this way the wheels will be supported and directed along the points until they pass into the spaces between the fixed rails of the main and sidetracks. After the wheels reach this position they are directed back onto the main track by substantially the means shown in my patent above referred to, for accomplishing the same purpose. In other words, as herein shown, the spaces between the rails 3—7 and 4—6 are provided with a suitable filling 18 which may be formed of metal or other suitable material, and the operation of this part of the device is similar to that in my patent above referred to and the construction

is substantially the same except that I do not find it necessary to groove the main rail, but instead I provide a vanishing groove or space 19 between the outer surface of the main rail 4 and the diagonal rail 6, which raises the wheel so that it passes over the top of the main rail 4.

When the points are in the position shown in Fig. 1 a train passing toward the points will have its flanges taken upon the filling pieces 13, and these filling pieces will direct the trains back onto the main track in the manner above described; but if the head rod or the connecting rod between the points and the stand 15 should be broken or the stand should be turned so as to partially open the switch, the weight of the train upon the points would tend to move the points so as to cause them to connect with the side track, in which case one or more of the trucks, or one or more of the cars having passed over the safety device and gone back on the main track, the other trucks or cars would be directed by the points onto the sidetrack. This would either throw the train from the track or injure the cars or the track. For the purpose of preventing this I provide the locking device which, as herein shown, consists of the shaft 21 which is journaled at its outer end in a hole or opening in the rail 5 and at its inner end in a block 23' arranged on the plate 23 fastened on the ties, and which is split, as shown, so that one part 23³ forms a spring pressing against the flat side of a collar 21² fastened on the shaft 21 to hold the same from turning. Next to the spring plate is a flat plate 25 spiked upon the ties. The shaft 21 passes through an opening in the switch point 10, and this shaft is provided with the upwardly projecting curved arm 27 that is arranged to pass through a hole 29 in the filling piece 13. This shaft is also provided between the point 10 and the plate 25 with the depending head or arm 31, the lower end of which is provided with a projection 33.

When the arm 27 is in its normal position it projects through the hole 29 and stands above the upper surface of the filling piece 13, and the depending arm 31 is then in position with its lower end above the plate 25. The shaft 21 is secured by the arm 27 to the point 10, so that as said point is moved toward and from the rail 5 said shaft moves with it, the arm 33 passing above the plate 25. Should the wheels, however, remain outside of the points with their flanges upon the filling pieces 13, the flanges coming in contact with the end of the arm 27 would depress said arm, turning the shaft 21 upon its axis and bringing the lower end of the arm 31 below the plate 25, the point at the lower end of said arm preferably striking the edge of the rail base. This will effectually lock the point 10 in this position and prevent it from moving any farther from the rail 5, while still leaving it free to move toward said rail 5.

For the purpose of holding the shaft normally in position with the arm 27 in an elevated position, I provide the lever 37, which is arranged to lie along the outside of the rail 5 and is provided with a foot piece 39 at its end. When the shaft 21 is in position with the arm 27 elevated, this lever occupies such a position as is indicated. A spring 41 is arranged preferably within the housing 50 and holds the lever either in its depressed or its elevated position. When the arm 27 is depressed and the end of the lever 37 elevated, the foot piece 39 will stand above the top of the rail 5 in a position where it will be engaged by the tread of a wheel passing toward the switch from the side track; or this lever may be depressed by any person stepping or pressing upon the foot piece 39, and thereby pushing the lever down to its lower position where it will be held by the spring 41. This spring 41 is adapted to sustain the weight of the lever when it is raised by the forcing down of the part 27. This is necessary as the flat side of the collar 21² is not at such time in contact with the flat spring beneath and the shaft might be jarred back so as to remove the arm 31 from the desired position. The collar 21² is preferably used while if the spring 41 was made strong enough it alone might be relied upon. The end of the shaft is made square and the opening in the end of the lever 37, while of the same shape is considerably larger to permit the end of the shaft to move freely back and forth with the switch point, the lever being preferably held from such movement by two lugs 43 or stationary collars fastened at the side of the rail 5. The outer end of the shaft is extended as shown, and provided with a head 42, between which and the outer stationary lug 43 is a strong spring adapted to draw the switch point over against the rail 5 as soon as the former is in any way released. The head 42 has an arm or lug 44 extending close to the wall of the housing and adapted to operate over the pivotal gravity catch 45 thereon. The outer end has a series of notches 46 and the inner end is heavier, so that the notched end is held up to engage the arm or finger 44 when the latter is pushed on by the closing of the switch. The result is that the shaft, and hence the switch points, are locked back against any accident to the spring, which would render the latter and the switch unreliable. Stop pins 47 and 48 are provided beneath the ends of the catch lever or bar to limit the movement thereof, and when the lever 37 is thrown down the finger 44 is raised therefrom to permit the movement of the switch points away from the rail 5.

It is obvious that various modifications of my invention would readily suggest themselves to one skilled in the art, and I therefore do not wish to confine myself to the precise construction shown and described.

Having thus described my invention, I

claim as new and desire to secure by Letters Patent—

1. In a point switch, the combination, with the two movable points, of filling pieces secured to the outer sides of said points, and adapted to receive and support the flanges of the wheels when they leave the divergent ends of the main rails, substantially as described.

2. In a point switch, the combination, with the movable points, arranged to permit the wheels to pass outside of both points when the switch is partially open or in a neutral position, of the filling pieces secured to the outside of the points and adapted to receive and support the flanges of the wheels, for the purpose set forth.

3. The combination, with the stock rails 2 and 5 and the rails of the main and the side tracks, of the movable points provided with filling pieces secured to their outer sides, and means for guiding the wheels back onto the main track after they leave the said filling pieces, for the purpose set forth.

4. The combination, with the movable points, provided with filling pieces arranged upon the outer side thereof, of a locking device connected with said points and arranged to be operated by the flange of a wheel passing along upon one of said filling pieces, substantially as described.

5. The combination, with a movable point, provided with a filling piece upon the outside thereof, of a locking device for said point arranged to be engaged by a wheel flange passing along on said filling piece, for the purpose set forth.

6. The combination, with the points 10 and 11, provided with filling pieces 13 arranged on the outside of said points, of the plate 25 secured upon the ties, the shaft 21 provided with the arm 27 arranged to project through an opening in the filling piece 13, and said shaft being provided also with the arm 31 adapted, when depressed, to engage the plate 25, for the purpose set forth.

7. The combination, with the movable point 10, provided with the filling piece 13, of the shaft 21 mounted in suitable bearings and provided with the arm 27 arranged to project through an opening in the filling piece 13, said shaft being also provided with the depending arm 31, the plate 25 secured upon the ties with which said arm 31 when depressed is adapted to engage, and suitable means for holding the arm 27 in an elevated position, substantially as described.

8. The combination, with the point 10, provided with the filling piece 13, of the shaft 21, provided with the arms 27 and 31, the lever 37, and a spring for holding said lever either in an elevated or depressed position, for the purpose set forth.

9. The combination, with the main rail, of the movable switch point, having filling piece 13, with the shaft 21 extending through both,

a fixed plate, an arm upon said shaft arranged to be moved into position to engage said plate, a second arm upon the shaft extending through an opening provided in said filling
5 piece, an operating lever arranged upon the outer part of said shaft, a pivoted gravity catch, and an arm or lug carried upon said shaft and adapted to be engaged by said catch

o lock said switch point against said rail, substantially as described. ^{to}

In testimony whereof I have hereunto set my hand this 22d day of August, 1893.

LOUIS DUNN.

In presence of—

F. S. LYON,

CHAS. E. VAN DOREN.