

May 9, 1933.

W. A. CROSS

1,908,659

GATE

Filed Feb. 1, 1929

2 Sheets-Sheet 1

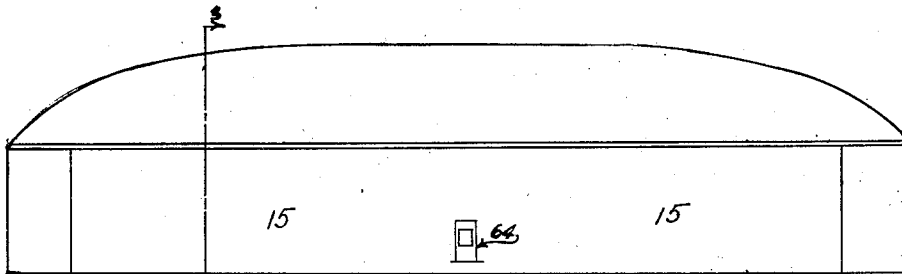

Fig. 1

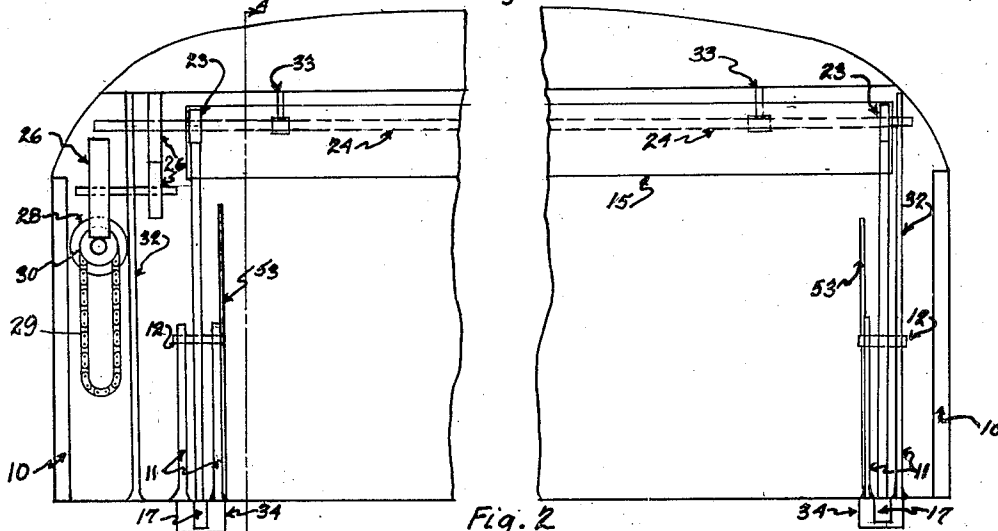

Fig. 2

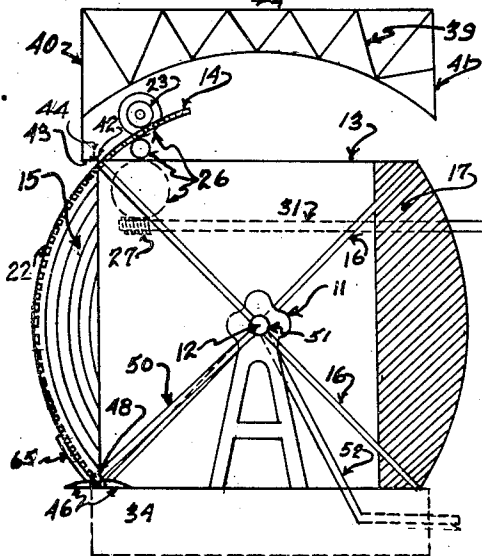

Fig. 3

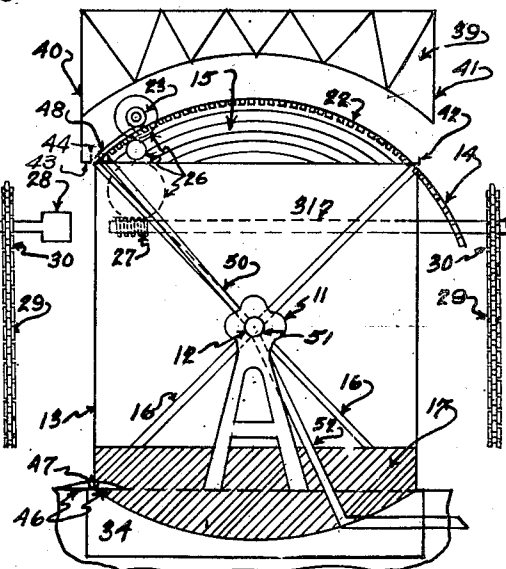

Fig. 4

Inventor:  
WILLIAM A. CROSS  
per Carl F. Pflieger  
Attorney

May 9, 1933.

W. A. CROSS

1,908,659

GATE

Filed Feb. 1, 1929

2 Sheets-Sheet 2

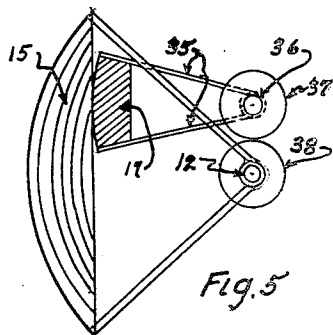

Fig. 5

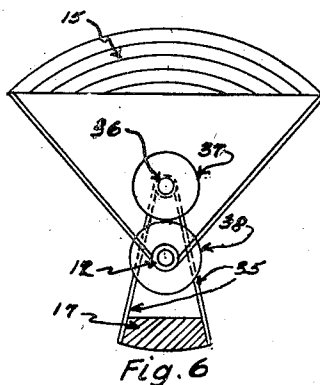

Fig. 6

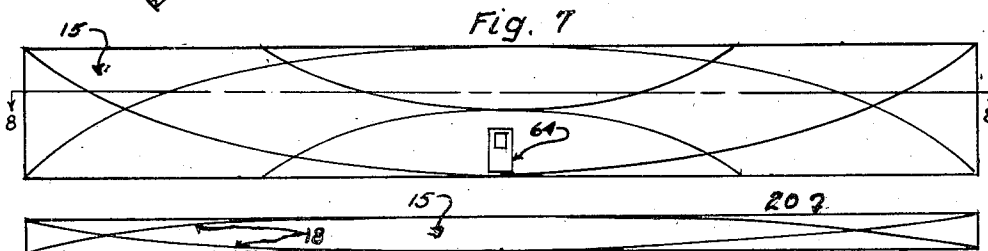

Fig. 7

Fig. 8

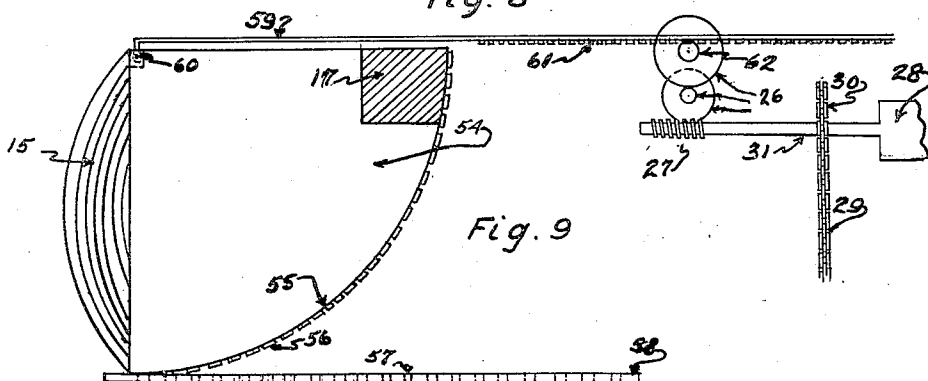

Fig. 9

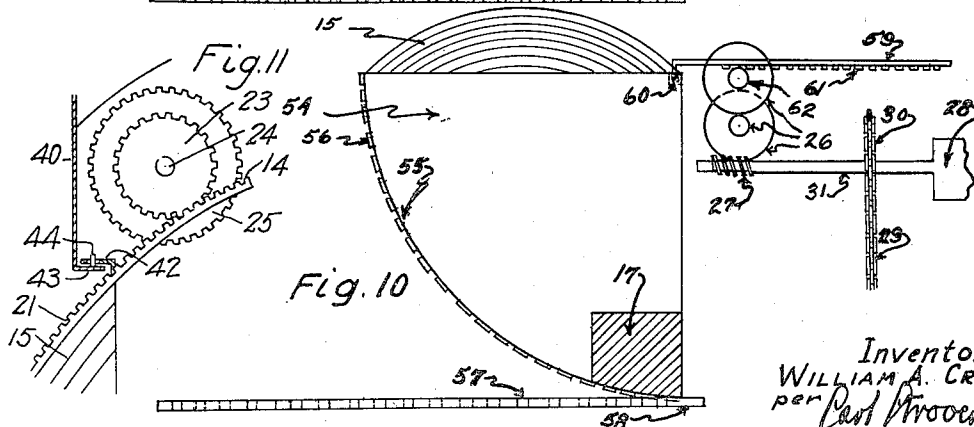

Fig. 11

Fig. 10

Inventor:  
WILLIAM A. CROSS  
per  
Carl Proctor  
Attorney

# UNITED STATES PATENT OFFICE

WILLIAM A. CROSS, OF CHICAGO, ILLINOIS, ASSIGNOR TO EARL F. CROSS, OF ELMHURST, ILLINOIS

## GATE

Application filed February 1, 1929. Serial No. 333,685.

The object of my invention is to provide a gate adapted particularly for use in airplane-sheds or hangars, that can be readily and safely operated to close or open a wide opening of comparatively low height, so as to make virtually the whole width of the opening available for ingress and egress while requiring support neither from the superstructure above it, nor from the ground below it; the objection to support from the superstructure being that it would require, with a wide span, the building of a heavy, expensive superstructure; and the objection to support from the ground being that in unfavorable weather operation of the gate is often attended with difficulties and considerable loss of time.

In the drawings, Fig. 1 is a front elevation of an airplane-shed provided with my gate in closed position; Fig. 2 is a like, enlarged, elevation with the gate open and certain parts broken away; Fig. 3 is a sectional elevation in the plane indicated by line 3—3 in Fig. 1; Fig. 4 is a like elevation in the plane indicated by line 4—4 in Fig. 2; Fig. 5 is a sketch of an alternate method of arranging the counterweights of my gate, showing the gate in closed position; Fig. 6 is a like sketch showing the gate in open position; Fig. 7 is a front elevation of my gate, with the covering broken away, indicating the principal vertical truss members of the preferred construction of my gate; Fig. 8 is a longitudinal section of my gate, in the plane of line 8—8 in Fig. 7, indicating the principal horizontal truss members of my gate; Fig. 9 is a sketch, showing my gate in closed position, attached to rolling frames, together with operating mechanism for this type of construction; Fig. 10 is a similar sketch with my gate in open position; and

Fig. 11 is an enlarged section of certain members hereinafter described.

Referring to the drawings, near the sides 10, built of any suitable material, such as concrete, masonry or steel, of an airplane-shed, there are mounted, within the shed and near its front entrance, on suitable supports 11, by means of axles 12, oscillatable frames 13, carrying between them, adjoining their circu-

larly rounded faces 14, gate 15, and, on extensions 16, counterweights 17. Gate 15 is preferably made convex-cylindrical on the outside, and flat on the inside, as shown in the drawings, and is preferably built of strong sheet-metal, extended over a suitable truss-frame 18, for which space is afforded between the outer covering 19 and the inner covering 20 of the gate. Faces 14, along their outer edges 21, are provided with cogs 22 into which mesh the cogs of two small driving gears 23 which are fixedly mounted on a shaft 24 adapted to be oscillated by a driven gear 25, operated by means of suitable transmission gears 26, through worm 27 which ordinarily is driven by a reversible electric motor 28, but may also be operated, in emergencies, by means of an endless chain 29, engaging sprocket wheel 30, mounted on worm gearshaft 31. Shaft 24 primarily is mounted in bearings 32 on supports 11, but is supported between these bearings by hangers 33 fastened to the roof supports above. Where drainage is ample, extensions 16 may be made long, carrying comparatively light counterweights 17, swinging, when gate 15 is raised, into pits 34, as shown in Fig. 4; but where drainage is not ample, extensions 16 may be made short, and counterweights 17 correspondingly heavier, so as to avoid the necessity of pits 34. It is also quite practicable, as shown in Fig. 5, to omit extensions 16, and to attach counterweights 17, by means of arms 35, rigidly to auxiliary axles 36 which are oscillatably mounted on supports 11 and have fixedly connected to them gears 37, meshing with gears 38, mounted on axles 12. Where this arrangement is employed arms 35 and counterweights 17 project, when my gate 15 is closed, in the same direction from axle 12 as gate 15.

To provide suitable space for my gate when in open position, and at the same time to strengthen the construction of the roof of the shed over the front entrance, I prefer to have the roof there supported by an arched truss-construction 39, extending from a front girder 40 to the next girder 41. In order to prevent excessive drafts of air over the top of my gate, I provide it above and along its upper edge with an astrigal 42, adapted to engage

an apron 43 which extends along the upper edge of the front-entrance of the airplane-shed and which is rigidly connected to the roof structure. This astragal and apron are preferably provided, one with pins 44, and the other with vertical openings 45, adapted to be engaged by pins 44, for the purpose of providing additional stability for my gate, when closed, against windpressure. The same purpose is served, along the bottom edge of my gate, by sloping cleats 46, set opposite to each other, so as to form between them troughs 47, which, being open at their ends, can be easily cleaned, and yet provide rigid seats to be entered by the lower edge of my gate when it is closed. In order to facilitate opening of my gate in severe freezing weather I provide along its lower edge, between outer covering 19 and inner covering 20, a steampipe 48, provided with suitable outlet 49 at one end, and connected at its other end to a supply pipe 50 which leads through the center of one of axles 12, to a swivel-joint 51 supplied with steam, when needed, from stationary steampipe 52. Rigid metal shields 53 are firmly connected to supports 11, to prevent contact between the movable parts mounted on supports 11 and persons and objects that may come near these moving parts. Throughout my construction I prefer to use ball-bearings or roller-bearings in order to make it as easy as possible to operate my gate.

In the alternate construction, indicated in Figs. 9 and 10, gate 15 is mounted on two frames 54, carrying counterweights 17 and provided along their rolling surfaces 55 with teeth 56, adapted to enter openings 57 in beds 58. Drawbars 59 have their curved-down front ends oscillatably connected, by means of pins 60, to frames 54 near the forward ends of these frames, and are provided along their rear ends with rack teeth 61 into which mesh gears 62, mounted on shaft 63,—said gears and shaft being mounted and operated in all respects substantially as above set forth with reference to shaft 24, except that they are located much farther from the entrance of the shed than gears 23 and shaft 24. Since this construction in many respects appears to be less desirable than the one above set forth in detail, I refrain from describing it with greater particularity.

In order to facilitate exit and entrance of persons, when my gate 15 is closed, I prefer to provide at least one small door 64 in my gate 15. This small door is preferably set some distance above the bottom of gate 15 so as to weaken its framework as little as possible, and so as not to interfere with steampipe 48, and is preferably arranged to open outwardly so as to avoid all chance of its flopping open and getting into the way of airplanes when gate 15 is open.

It will be apparent to any engineer or mechanic, without further elucidation, that

gate 15 can readily be swung from the position shown in Figs. 1, 3 and 5 to the position shown in Figs. 2, 4, and 6, and vice versa, by the proper operation of motor 28, or chain 29; and that in the construction indicated in Figs. 9 and 10, gate 15 can by similar means as readily be swung from the closed to the open position and vice versa.

Explaining further the construction of gate 15, I prefer to embody into it a double vertical truss, as indicated in Fig. 7, and a double horizontal truss, as indicated in Fig. 8. Suitable bracing, not shown in the drawings, is employed for connecting and stiffening the various parts of my gate, and the inner covering 20, as well as the outer covering 19, is firmly connected to the framework, so as to serve as reinforcements of the truss framework and as integral parts of the bracing structure of my gate. The great advantage of constructing my gate in the manner described will be readily apparent to any engineer when it is considered that airplanes are getting larger and larger, and that even now entrance openings 20 feet or more in height, and one hundred fifty feet in width, are occasionally required. The wind-pressure upon a gate of this size, in a gale, requires great stoutness of construction. So likewise does the width of a span of 150 or more feet, for a gate that is to be bodily lifted by means connected to the side-ends of the gate. Yet it is manifestly desirable to reduce the weight of such a gate as much as practicable. These requirements cannot be met to like advantage by any other construction than the one indicated by me.

While my gate is primarily designed for use in airplane sheds, it is adapted also for use in wharves, warehouses, entrances to fair grounds, factories and other places.

Manifestly its construction and operation may be modified in many respects without departure from the essentials of my invention. All such modifications I intend to cover by my claims.

I claim—

1. In connection with an entrance opening, the combination of a closure, adapted to close the opening; members located at the sides of the opening, carrying the closure, and adapted to move the closure from a substantially vertical position to a substantially horizontal overhead position, and vice versa; means, located on both sides of the opening, for actuating the carrying members; and apparatus for operating the actuating means in unison, said apparatus including a horizontal overhead shaft located outside of the pathway traversed by the closure in opening and closing.

2. In connection with an entrance opening, a closure adapted to close the opening, presenting, in vertical cross-section, a rounded outer face and a substantially flat inner face,

and constructed of a rigid metal truss-frame combined with suitable metallic covering, forming a reinforcement of the truss-frame, in combination with means for moving the closure from a substantially vertical position to a substantially horizontal overhead position, and vice versa.

3. In connection with an entrance opening, a closure, adapted to close the opening, presenting, in vertical cross-section, a rounded outer face, and constructed of a rigid metal truss-frame combined with suitable metallic covering, forming a reinforcement of the truss-frame, in combination with members located at the sides of the opening, carrying the closure, and adapted to move the closure from a substantially vertical position to a substantially horizontal overhead position, and vice versa; means, located on both sides of the opening, for actuating the carrying members; and apparatus for operating the actuating means in unison, said apparatus including a horizontal overhead shaft located outside of the pathway traversed by the closure in opening and closing.

4. In connection with an entrance opening, the combination of a closure adapted to close the opening; members located within the opening, at each side thereof, carrying the closure, and adapted to move the closure from a substantially vertical position to a substantially horizontal overhead position, below the roof of the structure containing the opening, and vice versa; and means, other than the closure itself, for actuating both of the carrying members in unison.

5. In connection with an entrance opening, the combination of a closure, not supported by the superstructure of the opening and adapted to close the opening; means for moving the closure from a substantially vertical position to a substantially horizontal overhead position, and vice versa; a suitable flange projecting beyond the face of the closure about its upper edge; and a member attached to the superstructure of the opening, and adapted to be engaged by the flange.

6. In connection with an entrance opening, the combination of a closure, not supported by the superstructure of the opening and adapted to close the opening; means for moving the closure from a substantially vertical position to a substantially horizontal overhead position, and vice versa; a suitable flange projecting beyond the face of the closure about its upper edge; a member attached to the superstructure of the opening and adapted to be engaged by the flange; and means for locking the flange to the member, against horizontal movement.

7. In connection with an entrance opening, the combination of a closure, not supported by the superstructure of the opening and adapted to close the opening; means for moving the closure from a substantially vertical

position to a substantially horizontal overhead position, and vice versa; a suitable flange projecting beyond the face of the closure about its upper edge; a member attached to the superstructure of the opening and adapted to be engaged by the flange; said flange and member being provided with pins and with openings, to be entered by the pins, for locking the flange to the member against horizontal movement.

8. In connection with an entrance opening, the combination of a closure adapted to close the opening; members located within the opening at each side thereof, carrying the closure, and adapted to move the closure from a substantially vertical position to a substantially horizontal overhead position, and vice versa; and means, other than the closure itself, for actuating both of the carrying members in unison.

9. In connection with an entrance opening, the combination of a closure adapted to close the opening; oscillatable members located within the opening at each side thereof, carrying the closure, and adapted to move the closure from a substantially vertical position to a substantially horizontal overhead position and vice versa; axles on which the members are mounted; means for actuating the carrying members in unison; and a pipe attached to the closure near and along its lower edge and connected, through one of the axles, to a suitable steam supply.

WILLIAM A. CROSS.

70

75

80

85

90

95

100

105

110

115

120

125

130