

March 7, 1950

E. K. CLARK

2,500,062

APPARATUS FOR DRYING FABRICS OR THE LIKE

Filed April 1, 1947

2 Sheets-Sheet 1

Fig. 1.

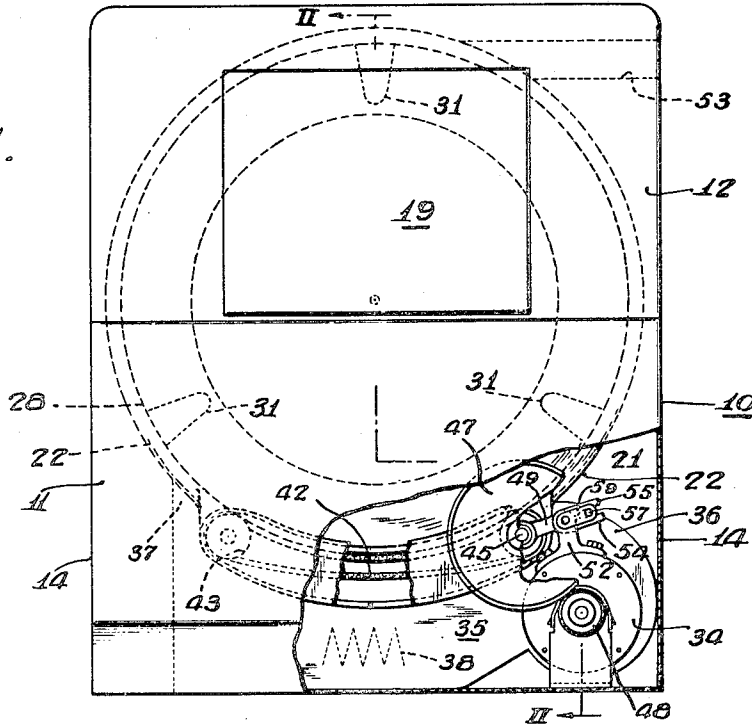
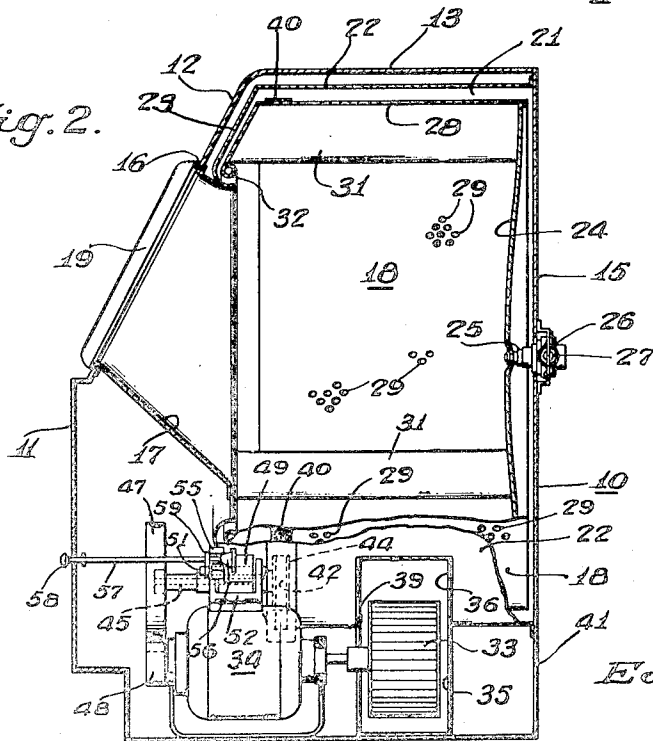

Fig. 2.



INVENTOR
E. K. Clark
BY *Ed. Small*
ATTORNEY

March 7, 1950

E. K. CLARK

2,500,062

APPARATUS FOR DRYING FABRICS OR THE LIKE

Filed April 1, 1947

2 Sheets-Sheet 2

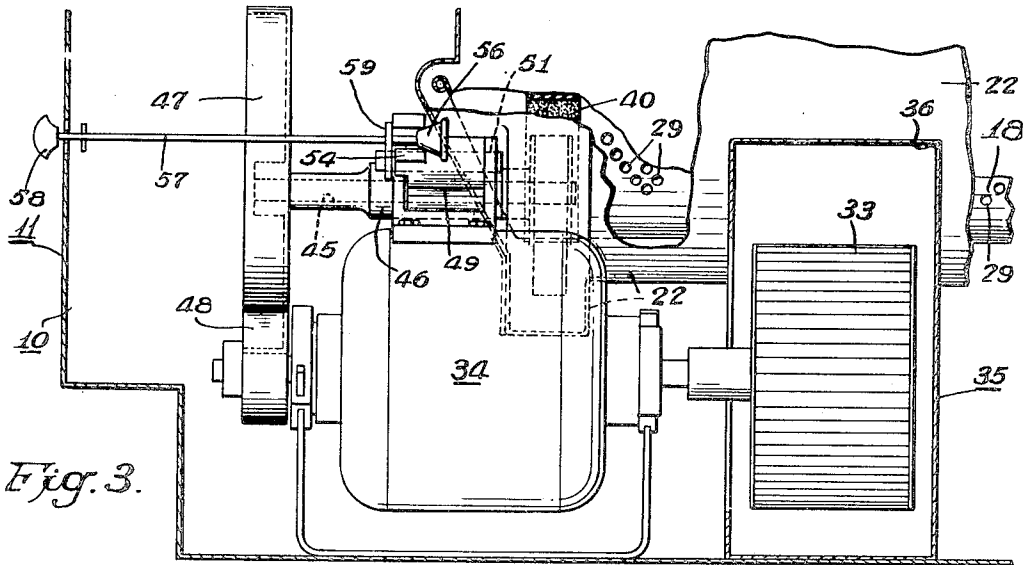

Fig. 3.

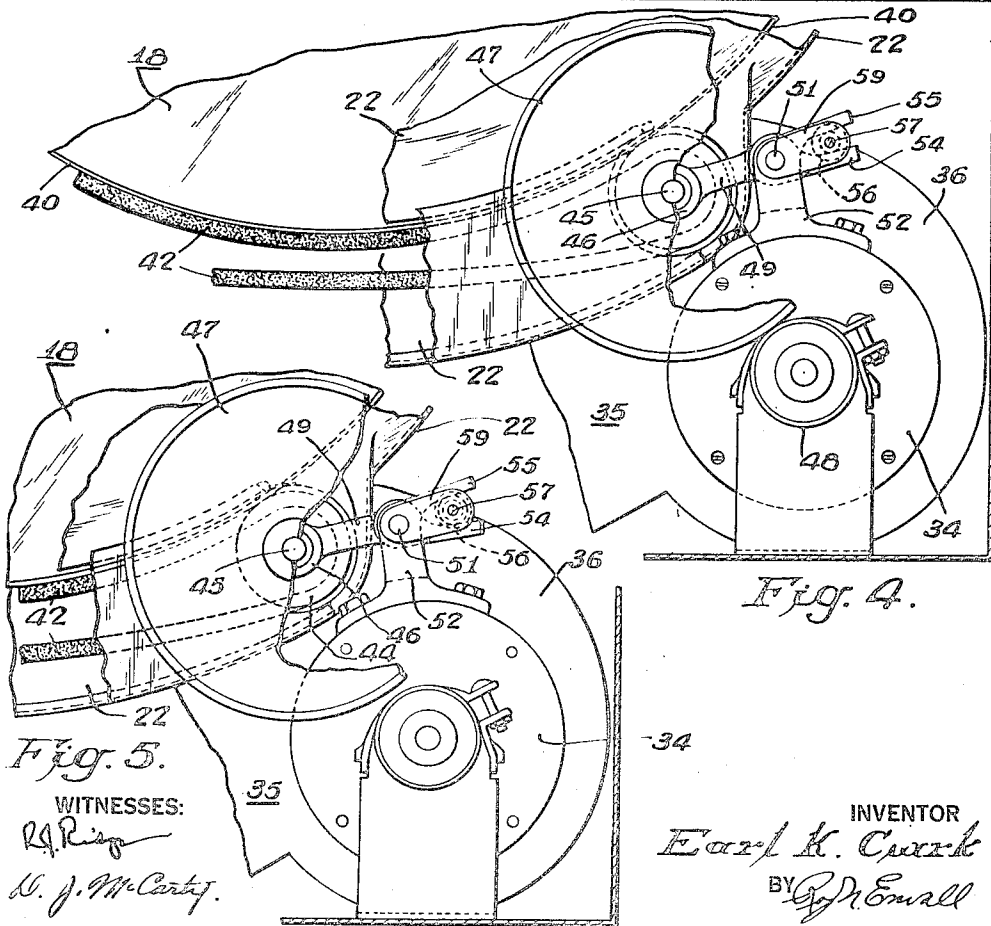

Fig. 4.

Fig. 5.

WITNESSES:

R. R. Rice
W. J. McCarty

INVENTOR
Earl K. Clark
 BY *G. D. Small*
 ATTORNEY

UNITED STATES PATENT OFFICE

2,500,062

APPARATUS FOR DRYING FABRICS OR THE LIKE

Earl K. Clark, Mansfield, Ohio, assignor to Westinghouse Electric Corporation, East Pittsburgh, Pa., a corporation of Pennsylvania

Application April 1, 1947, Serial No. 738,713

3 Claims. (Cl. 34—139)

1

My invention relates to apparatus for drying fabrics and the like and has for an object to provide improved apparatus of this kind.

A further object of my invention is to provide, in a dryer of the type set forth, provisions for drying the material with or without tumbling, depending on the character of the material being treated.

These and other objects are effected by my invention as will be apparent from the following description and claims taken in connection with the accompanying drawings, forming a part of this application, in which:

Fig. 1 is a front elevation of a domestic clothes dryer constructed and arranged in accordance with my invention, portions of the casing being broken away to show the driving mechanism for the basket of the dryer;

Fig. 2 is a vertical section taken along the line II—II of Fig. 1 with portions broken away for clearness;

Figs. 3 and 4 are enlarged views of the basket drive mechanisms shown, respectively, in Figs. 2 and 1; and

Fig. 5 is a view similar to Fig. 4, showing portions of the drive mechanism in a different or inactive position.

Reference will now be had to the drawings wherein I have elected to disclose my invention applied to a domestic clothes dryer generally of the type disclosed and claimed in the copending application of Francis J. Broglie, Serial No. 555,959, filed September 27, 1944, now Patent Number 2,424,737. In this form of dryer, the drying and air translating mechanism is enclosed in a housing 10 having a front wall 11, the upper portion of which is inclined rearwardly and upwardly as shown at 12. The housing includes a top wall 13, side walls 14 and a rear wall 15. The inclined front wall portion 12 is provided with an access opening 16 which communicates with a chute structure 17, the latter directing fabrics dropped through the opening 16 to the interior of a rotatable basket structure, generally indicated at 18 and arranged within the housing 10. The access opening 16 is closed by a suitable door or cover 19 which may be hinged in any well-understood manner to the front wall 11.

The basket 18 is rotatable about a generally horizontal axis within a drying chamber 21, the

2

latter being enclosed within a casing having a generally cylindrical side wall 22 and a front wall 23 which is joined to the inner end of the chute 17 in any well-understood manner. The cylindrical side wall 22 preferably extends to the rear wall 15 and is joined thereto.

The basket 18 includes a rear wall 24 having a stub shaft 25 fixed thereto, the latter being journaled in a bearing 26 hinged, as shown at 27, to the rear wall 15; the construction and arrangement being such that the bearing may rock through a limited range of movement in a generally vertical plane. Since the rockable bearing structure per se which I have just described forms no part of the present invention, further description of the same is deemed unnecessary. A bearing of this type is disclosed and claimed in connection with a dryer in the copending application of William A. Johnston, Serial No. 689,657, filed August 10, 1946.

The basket 18 also includes a cylindrical side wall 28 which is perforate, substantially, throughout its extent, a few of the perforations being indicated at 29. The basket 18 is also provided with a plurality of radially, inwardly-extending vanes or baffles 31 for tumbling the fabrics during rotation of the basket 18. The basket is further provided with a relatively large access opening 32 which communicates with the inner end of the chute 17.

Air for drying the clothes is translated to the drying chamber 21 by a rotatable fan rotor 33 which is driven by an electric motor 34 suitably supported in the bottom of the housing 10. The fan rotor 33 translates air through a duct 35, one end of which is shaped to form a fan casing 36, the opposite end of the duct communicating with an opening 37 formed in the cylindrical side wall 22. Air heating means of any well-understood construction is provided within the duct 35 for heating the air translated therethrough. For example, I have diagrammatically shown at 38 an electric heater for this purpose. The air translated by the fan 33 is drawn into the fan casing 36 through an opening 39 which communicates with the interior of the casing 10. Air from the ambient atmosphere enters the housing 10 through a suitable opening 41 shown, for example, in the back wall 15 of the housing (see Figure 2).

Rotation of the basket is effected by a friction drive mechanism of the type disclosed and claimed in the aforementioned application of William A. Johnston and including an endless belt 42 which engages an arcuate portion of the underside of a driving band 40 carried on the exterior of the basket 18 at the front end thereof (see Figure 2). The belt extends between an idler pulley 43 suitably journaled within the housing 10 in any well-understood manner and a driving belt pulley 44. The belt 42 defines the support for the front end of the basket 18 which, as best shown in Figure 1, is saddled in the belt 42 intermediate the pulleys 43 and 44.

As best shown in the enlarged views Figs. 3 to 5, inclusive, the belt pulley 44 is driven by a jackshaft 45, the latter being journaled in a suitable bearing 46. The jackshaft 45 carries a friction wheel 47 at its opposite end engageable with a smaller friction wheel 48 driven by the electric motor 34. The bearing 46 is supported by a lever 49 which is pivoted, as shown at 51, to a bracket 52 carried by the frame of the electric motor 34. The drive mechanism described up to now is the invention of William A. Johnston and is described and claimed in his aforementioned copending application, Serial No. 689,657. Generally speaking, the purpose of this drive mechanism is to provide good driving contact between the belt 42 and the driving band 40 regardless of any eccentricity of the latter. In this connection, if the driving band 40 is slightly eccentric, rocking movement of the basket in a vertical plane is afforded by the pivoted bearing 26.

During operation of the dryer, the motor 34 operates to rotate the basket 18 at a relatively low speed of, for example, 50 R. P. M. to tumble the fabrics within the basket. The fan rotor 33 translates air through the duct 35 wherein it is heated, the heated air then passing through the opening 37 to the drying chamber 21. The heated air passes through the numerous perforations 29 and contacts the tumbling fabrics for the extraction of moisture therefrom. The moistened air is discharged from the drying chamber 21 through a suitable duct 53 (Fig. 1) to the ambient atmosphere.

It is frequently necessary to dry articles in a domestic dryer, which should not or cannot be tumbled, such as, for example, canvas shoes or gloves which are drawn upon a drying form. In accordance with my invention, means readily accessible to the operator is provided for terminating the rotation of the basket 18 while permitting the motor and the fan to operate for the circulation of heated air through the stationary basket 18. The mechanism which I provide for controlling rotation of the basket 18 operates to raise the jackshaft 45 sufficiently to disengage the friction wheels 47 and 48 when rotation of the basket is to be terminated. This operation, of course, raises the front end of the basket 18 slightly, which movement is permitted by the pivoted journal bearing 26 supporting the rear end of the basket. Upward movement of the jackshaft 45 and its bearing 46 about the pivot 51 is effected by depressing an arm 54 which is fixed to the lever 49. A projection 55 is aligned with the movable arm 54 and is fixed to the bracket 52. Intermediate the arm 54 and projection 55 is a frusto-conical wedge 56 which is manually actuated by a rod 57 having handle 58 secured there-
 10
 15
 20
 25
 30
 35
 40
 45
 50
 55
 60
 65
 70
 75

in Figures 3 and 4 wherein contact is maintained between the friction wheels 47 and 48. In order to terminate operation of the basket, the handle 58 is drawn outwardly to enter the wedge 56 between the arm 54 and projection 55. This operation forces the arm 54 downwardly and the lever 49 upwardly to disengage the friction wheels 47 and 48. This position of the apparatus is shown in Figure 5. In order to properly position the wedge 56 with respect to the arm 54 and projection 55, a supporting lever 59 is provided, the latter being loosely or pivotally mounted on the pivot 51 at one end and provided with an opening at its opposite end within which opening, the rod 57 is slidably supported. The front end of the rod 57 may be slidably supported by the front wall 11 in any well-understood manner.

From the foregoing description, it will be apparent that I have provided an improved dryer for fabrics or the like wherein drying may be carried out with or without tumbling, depending upon the nature of the material being treated. These methods of operation may be selectively carried out, at the will of the operator, by the actuation of a single handle.

While I have shown my invention in but one form, it will be obvious to those skilled in the art that it is not so limited, but is susceptible of various changes and modifications without departing from the spirit thereof.

What I claim is:

1. In apparatus for drying fabrics or the like, the combination of a basket for containing the fabrics and rotatable about a generally horizontal axis for tumbling the fabrics, a fan for translating air through the basket to abstract moisture from the fabrics during all periods of operation of the fan, a motor connected to said fan, a circular driving band carried by the basket, a frictional transmission intermediate said band and the motor for rotating the basket, said transmission including a friction pulley driven by the motor, a jackshaft, a friction wheel carried by the jackshaft and engageable with said pulley, friction means driven by the jackshaft and engaging said band, a bearing supporting the jackshaft means for supporting the bearing and providing for movement thereof to an inactive position wherein said wheel is disengaged from the first pulley to terminate rotation of the basket, a member engaging said bearing for actuating the latter to its inactive position and a manually-actuated handle for operating said actuating member.

2. In apparatus for drying fabrics or the like, the combination of a basket for containing the fabrics and rotatable about a generally horizontal axis for tumbling the fabrics, a fan for translating air through the basket to abstract moisture from the fabrics during all periods of operation of the fan, a motor connected to said fan, a circular driving band carried by the basket, a frictional transmission intermediate said band and the motor for rotating the basket, said transmission including a friction pulley driven by the motor, a jackshaft, a friction wheel carried by the jackshaft and engageable with said pulley, a belt pulley driven by the jackshaft, a belt driven by the belt pulley and engaging said band, a bearing supporting the jackshaft, means pivotally supporting the bearing and providing for movement thereof to an inactive position wherein said wheel is disengaged from the first pulley to terminate rotation of the basket, a wedging mechanism engaging the bearing for actuating the latter to its inactive position and manually-actuated

5

means for operating said wedging mechanism.

3. In apparatus for drying fabrics or the like, the combination of a basket for containing the fabrics and rotatable about a generally horizontal axis for tumbling the fabrics, a fan for translating air through the basket to abstract moisture from the fabrics during all periods of operation of the fan, a motor connected to said fan, a circular driving band carried by the basket, a frictional transmission intermediate said band and the motor for rotating the basket, said transmission including a friction pulley driven by the motor, a jackshaft, a friction wheel carried by the jackshaft and engageable with said pulley, a belt pulley driven by the jackshaft and disposed adjacent the lower portion of the driving band, an idler pulley spaced from said second pulley and arranged adjacent the lower portion of the driving band, an endless belt carried by said belt pulley and the idler pulley and engaging the lower portion of the driving band, a bearing for sup-

6

porting the basket, means for pivotally supporting said bearing and providing for movement of the basket in a generally vertical plane, a journal bearing structure carried by said motor and rotatably supporting said jackshaft, a pivot movably supporting the bearing, a wedge engaging the bearing structure for moving said journal about its pivot to a position wherein said friction wheel is disengaged from said first-mentioned friction pulley and rotation of the basket is stopped and a handle for manually actuating said wedge.

EARL K. CLARK.

REFERENCES CITED

15 The following references are of record in the file of this patent:

UNITED STATES PATENTS

Number	Name	Date
158,821	Young	Jan. 19, 1875
2,389,433	Hough	Nov. 20, 1945