



US 20070023098A1

(19) **United States**

(12) **Patent Application Publication**

(10) **Pub. No.: US 2007/0023098 A1**

Cooke et al.

(43) **Pub. Date:**

Feb. 1, 2007

(54) **HOLDING ELEMENT FOR A DEVICE FOR MONITORING THE QUALITY ON A MECHANICAL WEAVING LOOM**

(30) **Foreign Application Priority Data**

Oct. 22, 2003 (CH) 1814/03

(75) Inventors: **Charles Cooke**, Royston (GB); **Chris Groombridge**, Stevenage (GB); **Patrick Waller**, Duebendorf (CH)

Publication Classification

(51) **Int. Cl.**
D03D 51/34 (2006.01)

(52) **U.S. Cl.** **139/370.2**

Correspondence Address:

BUCHANAN, INGERSOLL & ROONEY PC
POST OFFICE BOX 1404
ALEXANDRIA, VA 22313-1404 (US)

(57) **ABSTRACT**

The invention relates to a device for optically monitoring a woven web of endless fabric on a mechanical weaving loom or a winding device. The monitoring device includes a holding element and extends over the entire width of the woven web of endless fabric. The monitoring device is directly in contact with the woven web of endless fabric and is held indirectly on the mechanical weaving loom, in the region between a delivering roller and the winding of the web of endless fabric onto a cloth beam or a large roller parallel to the delivery roller. The holding element has an axle located on the monitoring device and an axle located on the mechanical weaving loom, the two axles extending parallel to each other and being interconnected by a pivoting arm.

(73) Assignee: **USTER TECHNOLOGIES AG**, Uster (CH)

(21) Appl. No.: **10/576,543**

(22) PCT Filed: **Oct. 14, 2004**

(86) PCT No.: **PCT/CH04/00624**

§ 371(c)(1),
(2), (4) Date: **Jun. 29, 2006**

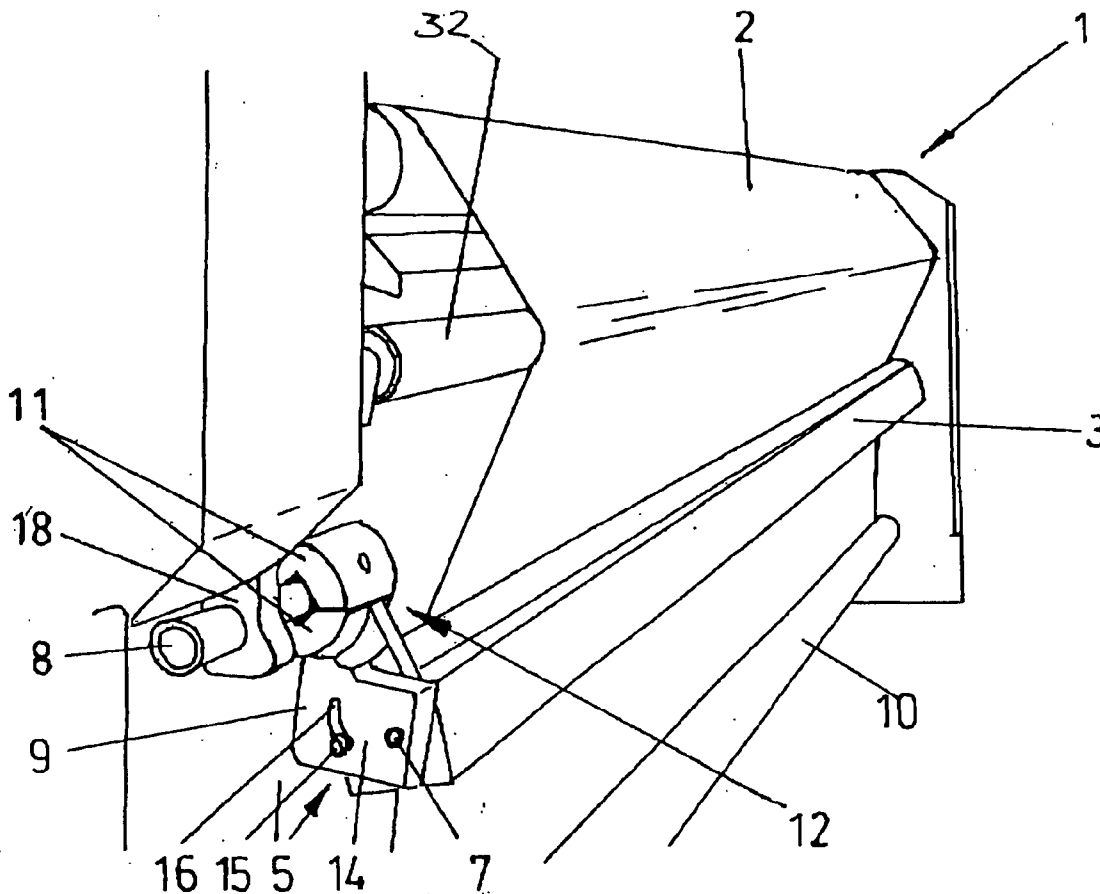
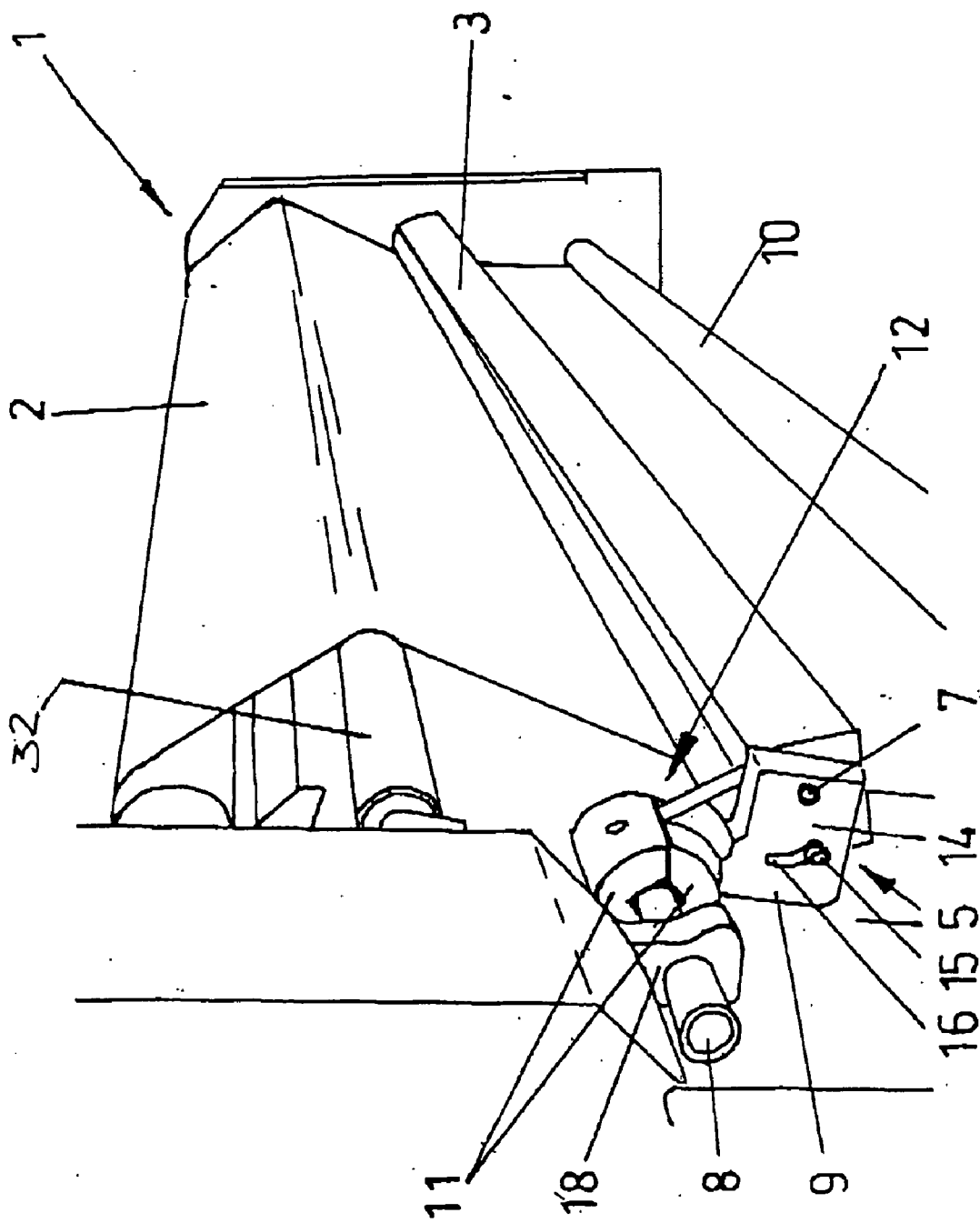

FIG. 1



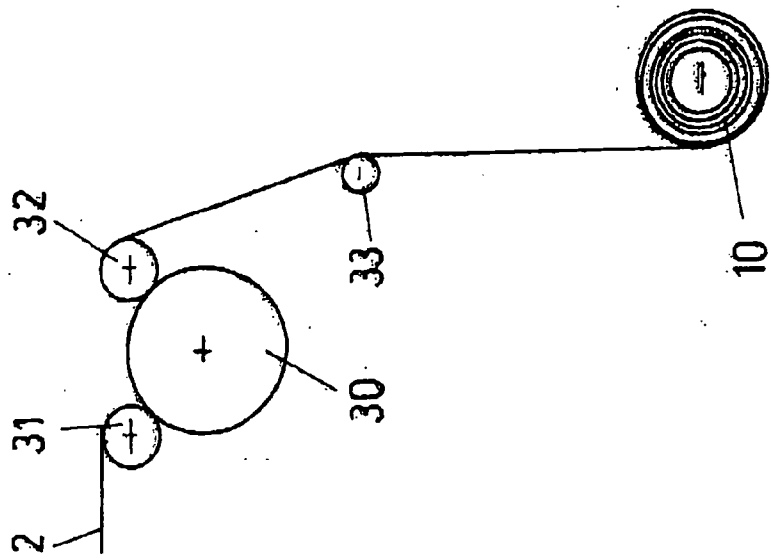

FIG. 4

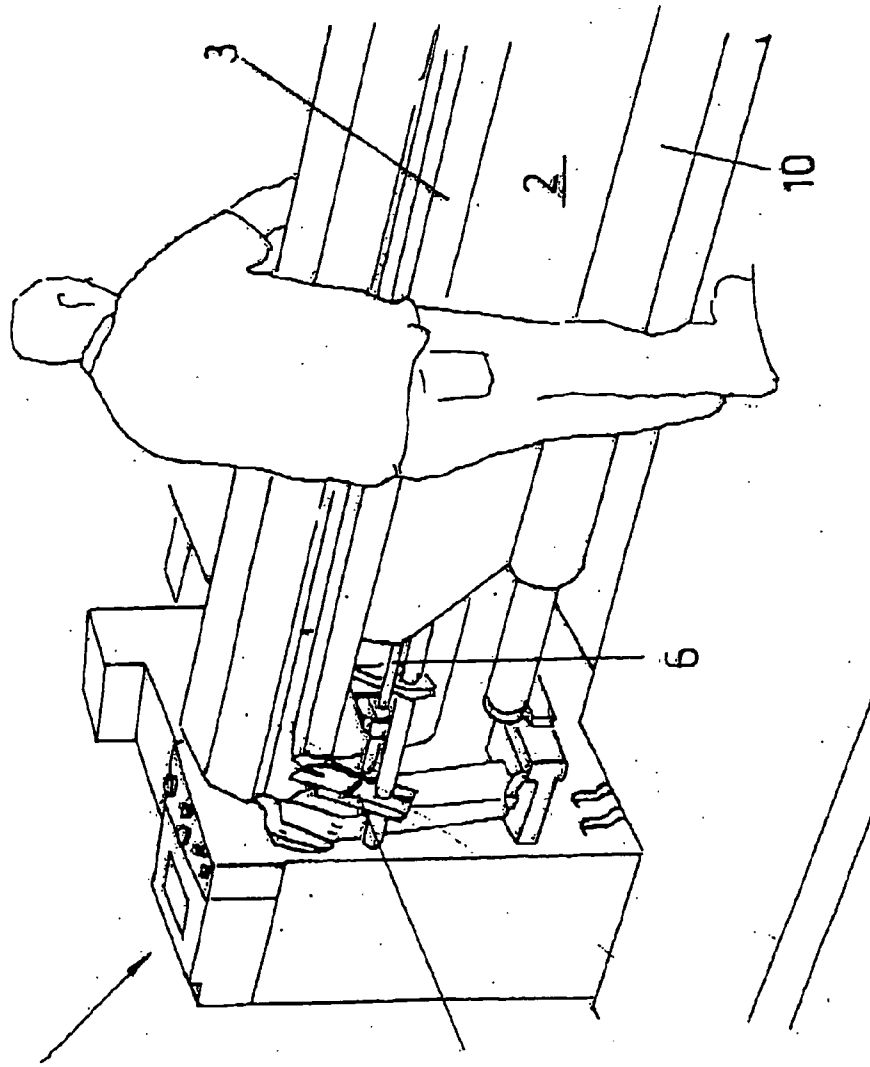

FIG. 2

**HOLDING ELEMENT FOR A DEVICE FOR
MONITORING THE QUALITY ON A
MECHANICAL WEAVING LOOM**

[0001] The present invention relates to a mounting for a device for the optical quality monitoring of a woven material web on a loom, including a mounting, in which the monitoring device extends over the entire width of the woven material web in accordance with the precharacterising clause of claim 1.

[0002] Devices of this kind are known for example from U.S. Pat. No. 4,728,800, WO-95/16909, CH-675 306 or in particular also from EP-A-1 249 530. Such devices are used in particular for the optical quality monitoring of a textile material web directly on the loom. Using these optical monitoring devices, virtually all quality defects occurring at the loom are to be recognised and detected electronically. Defects of this kind may be for example thread breakages of the weft or warp threads, blotches or other visual defects deviating from the usual appearance of the weaving. So that such defects may be recognised, the images detected must be as high-contrast and sharp as possible. To achieve high-contrast, sharp images, optical scanning as close to the material web as possible is required. Such devices are accordingly mounted directly on the loom and in contact with the woven material web.

[0003] It is known, however, that extremely pronounced resonance and vibrations occur on looms. While the natural resonance of the monitoring device can largely be cancelled out by corresponding structural features on the housing of the monitoring device, the vibrations have to be damped by other measures.

[0004] Conventionally, known inspection devices of this kind for material webs are fitted subsequently to looms of the most varied constructions. Because the monitoring device is connected to the loom, the vibrations of the loom are also transmitted to the optical monitoring device. It is thus of critical importance for the optical sensors to be able to be arranged as closely as possible to the textile material web to be monitored, on the one hand, and on the other for the mechanical connection between the optical monitoring device and the loom to be formed such that if possible the vibrations are not transmitted directly to the monitoring device.

[0005] Already known from DE-A-101'23'870 is an inspection device for material webs in which, in accordance with the diagram, a plate with a bore is secured to the two end faces of the device. These bores provide a "soft" suspension, the intention being for only one rotation to be possible about the suspension point. There is no further disclosure about the form required to achieve the "soft" suspension.

[0006] Furthermore, JP-A-09'78'444 discloses an inspection device for material webs in accordance with the precharacterising clause of claim 1, which is mounted such that it may be brought into contact with the woven material web in the region between a take-off roller and the winding point of the material web. However, there is no indication of the construction of the mounting.

[0007] This object is achieved by a mounting for a device for the optical quality monitoring of a woven material web having the features of claim 1.

[0008] The fact that the monitoring device is fitted in the region between the take-off roller and the point at which the material web is wound onto a loom beam or onto a large-scale winding roller is particularly significant here. Conventionally, a deflection or expanding roller is located in this region, and these stretch the woven material web flat before it is wound. This region is at a relatively great distance from the point at which the woven textile web is produced. Resonance and vibrations of the textile web itself are less pronounced here. Because, moreover, the material web is guided in contact with the monitoring device, the relative movements—with the exception of advance of the material web—are reduced. As a result of the indirect mounting in accordance with the invention of the monitoring device, by way of two pivot axes, the vibrations are also transmitted indirectly and hence to a reduced extent. As a result of these deflection points the vibrations are no longer transmitted directly and in addition the way the monitoring device is laid on the woven material web is precisely adjustable, and moreover it is possible to pivot the inspection device away for maintenance work without having to remove it from its mounting.

[0009] The construction of the indirect connection between the monitoring device and the loom is apparent from the further dependent claims.

[0010] Two example embodiments of the subject of the invention are shown in the attached drawings, and the details of the construction thereof are explained with reference to the description below.

[0011] In the drawings:

[0012] FIG. 1 shows a perspective partial view of a loom on which a monitoring device is mounted by means of the mounting according to the invention.

[0013] FIG. 2 shows, in turn, a perspective illustration of another loom having an alternative arrangement of the monitoring device, while

[0014] FIG. 3 shows a constructional alternative of a mounting of the monitoring device on a loom.

[0015] FIG. 4 serves to illustrate the preferred position at which the monitoring device is installed.

[0016] FIGS. 1 and 2 each show a loom 1 in a perspective partial view. The textile material web produced thereon is designated 2. In order to find any defects in the material web 2 which occur during production, an optical monitoring device 3 is arranged on the loom 1. This monitoring device, which extends in the shape of a beam over the entire width of the material web 2, scans the textile material web for example by means of scanners or other optical sensors. To obtain as perfect as possible an image and hence to obtain properly functioning quality monitoring, where on the loom 1 a monitoring device 3 of this kind is arranged is crucial. Trials on various looms have shown that optimum results are achieved in particular if the monitoring device 3 is arranged relatively closely upstream of the point at which the material web 2 is wound onto a loom beam 10, in particular in the region 6 between a take-off roller and the point at which it is wound-onto the loom-beam or the large-scale winding roller. The textile web is stretched flat before it is wound, by an expanding or deflection roller located here. Here, the material web 2 moreover has a desired tension. The optical

monitoring device 3 in this case bears directly against the material web 2. The wall of the monitoring device 3 facing the material web has appropriate windows behind which optical sensors, for example scanners, are arranged, protected by a transparent film.

[0017] FIG. 4 shows a diagrammatic partial section through a loom. Downstream of the actual weaving point, the finished textile material web is conveyed by means of a take-off roller 30, usually driven. The material web 2 is laid against the take-off roller 30 by way of a breast beam 31 and thereafter guided by way of one or more deflection rollers 32 into the region 6 in which the monitoring device is to be arranged in accordance with the invention. In this region 6, which lies upstream of the point at which the material web 2 is wound onto a loom beam or a large-scale winding roller and downstream of the take-off roller 30, there is usually a further deflection roller for the purpose of guiding, or an expanding roller 33 for flattening the material web before it is wound.

[0018] A wide variety of looms are available on the market, and they differ greatly in their construction. The possibilities for arranging the optical monitoring device between the take-off roller 30 and the loom beam 10 are correspondingly varied. FIG. 2 shows an alternative in which the monitoring device 3, on a different loom 1, is arranged upstream of the expanding roller or deflection roller 33 as seen in the direction of transport of the textile material web 2. Here too, however, the monitoring device 3 is arranged in the region of the take-off roller and the loom beam 10 or large-scale winding roller. Preferably, the monitoring device 3 will be mounted in the vicinity of the expanding roller 33 or the deflection roller 32 provided here in its stead, if these are provided on the loom. Wherever an expanding roller 33 is mentioned, a deflection roller provided in this region in its stead is always also included. In the present invention, the term "vicinity" is to be understood to mean that there are no other rollers or beams forming part of the loom which extend in contact with the textile web 2 between the point of contact for the optical monitoring device and the point of contact for the expanding roller.

[0019] The mounting according to the invention of the monitoring device 3 is designated 5 overall. It includes an axis 7 arranged on the monitoring device 3 and a second, parallel axis 8 arranged on the loom 1. The axis 7 on the monitoring device 3 is conventionally formed by two holding pins 13. These two holding pins 13 lie in a straight line forming the axis 7. The axis 8, which is mounted on the loom 1, may be a cross beam already provided on the loom or a tubular piece secured to the loom by means of a base part 18.

[0020] In the embodiment of FIG. 1, the mounting 5 has a sleeve 12 which is formed by two half-shells 11 and may be clamped to the axis 8 in a stable position. The embodiment having two half-shells 11 makes it possible to mount it on continuous axes, already present on the loom, of different diameters. One of the two half-shells 11 is here connected in one piece with the pivotal arm 9. The axis 7 of the monitoring device 3 is borne in this pivotal arm 9, which in this embodiment has a bearing housing 14. The bearing housing 14 substantially comprises a cheek in which the axis 7 of the monitoring device 3 is mounted to pivot. A clamping pin 15 passing through the housing 14 rests in an arcuate slot 16, as a result of which the monitoring device may be locked

relative to the material web 2, such that it may be pivoted about the axis 7 over a certain angular range.

[0021] The mounting 5 by way of two axes 7, 8 results in a wide range of adjustability for the monitoring device 3 relative to the material web 2. In principle, it is conceivable to arrange the monitoring device directly fixed to the loom 1 by means of base parts. However, this would result in the vibrations of the loom being transmitted directly to the monitoring device 3, which would cause a deterioration in the optical image. By mounting it indirectly by way of the two axes 7 and 8, the vibrations are transmitted less directly and the vibrations which still occur are additionally damped by the textile web on which the monitoring device 3 lies. By means of the mounting according to the invention, not only is an optimised arrangement consequently produced with a wide range of adjustability for the monitoring device relative to the textile web 2 but at the same time the optical result is improved because vibrations are transmitted less directly. It goes without saying that for this purpose the bearings may also be provided with appropriate bearing fittings which additionally result in the absorption of vibrations.

[0022] FIG. 3 diagrammatically illustrates an alternative form of the mounting 5. Here, once again the monitoring device 3 bears against the material web 2 in the region 6 downstream of the expanding roller 33 (also called a spreader beam), as seen in the direction of transport of the textile web. Clearly visible is the holding pin 13 which forms the axis 7 on the monitoring device 3. The axis 8 which is connected to the loom 1 is also visible. Here, the connection between this axis 8 and the loom 1 is not illustrated. The pivotal arm 9 substantially comprises a double-sided clamping mounting. The pivotal arm 9 is made from a rod. This rod has two bearing bores 19 through each of which a slot 20 passes diametrically. By means of clamping screws 21, the pivotal arm 9 can be locked on the one hand in an adjustable angular position with respect to the loom 1 and on the other in an adjustable angular position with respect to the monitoring device 3. Accordingly, once again the monitoring device 3 can pivot to a greater or lesser extent towards the textile material web 2 and on the other hand the monitoring device can be arranged at a relative angle with respect to the material web 2. Both directions of movement are crucially important for optimum optical scanning of the material web 2.

LIST OF REFERENCE NUMERALS

- [0023] 1 Loom
- [0024] 2 Textile material web
- [0025] 3 Optical monitoring device
- [0026] 5 Mounting
- [0027] 6 Region in which the monitoring device is arranged
- [0028] 7 Axis on monitoring device 3
- [0029] 8 Axis on loom 1
- [0030] 9 Pivotal arm
- [0031] 10 Loom beam or large-scale winding roller
- [0032] 11 Half-shells
- [0033] 12 Sleeve

- [0034] 13 Holding pin on monitoring device
- [0035] 14 Bearing housing on pivotal arm 9
- [0036] 15 Clamping pin
- [0037] 16 Arcuate slot
- [0038] 17 Clamping bearing for angular adjustment
- [0039] 18 Base part
- [0040] 19 Bearing bores
- [0041] 20 Slot
- [0042] 21 Clamping screws
- [0043] 30 Take-off roller
- [0044] 31 Breast beam
- [0045] 32 Deflection roller
- [0046] 33 Expanding roller or deflection roller

1. A mounting for a device for the optical monitoring of a woven material web on a loom, including a mounting, in which the monitoring device extends over the entire width of the woven material web, in which the monitoring device is mounted, indirectly connected to the loom, in contact with the woven material web in the region between a take-off roller and the point at which the material web is wound onto a loom beam or onto a large-scale winding roller and parallel thereto, wherein this mounting comprises an axis on the monitoring device and an axis on the loom, and the two axes extend parallel to one another and are connected to one another by way of a pivotal arm.

2. A mounting according to claim 1, wherein the mounting on the axis connected to the loom is performed by means of a sleeve formed by two half-shells, with the pivotal arm secured to one half-shell.

3. A mounting according to claim 2, wherein the pivotal arm is connected in one piece with one of the two half shells.

4. A mounting according to claim 2, wherein to each side of the monitoring device there is arranged a bearing pin, with the bearing pins lying in a straight line and forming the axis (7) of the monitoring device.

5. A mounting according to claim 1, wherein a bearing housing is integrally formed with the pivotal arm and the bearing pins of the monitoring device are mounted pivotally in this bearing housing, and wherein a pin extending parallel to the bearing pin is borne such that it may be clamped and pivoted in an arcuate slot for the angular positioning of the monitoring device.

6. A mounting according to claim 1, wherein the pivotal arm is in the form of a rod which is provided at both ends with a clampable bearing capable of angular adjustment.

7. A mounting according to claim 1, wherein it holds the monitoring device such that it may pivot about both axes to lie against the material web in the region in the vicinity of an expanding roller or a deflection roller of the loom.

8. A device according to claim 7, wherein the mounting holds the monitoring device such that it may pivot about both axes to lie against the material web in the region directly upstream, in relation to the direction of transport of the textile material web, of the expanding or deflection roller.

9. A device according to claim 7, wherein the mounting holds the monitoring device such that it may pivot about both axes, to lie against the material web in the region directly downstream, in relation to the direction of transport of the textile material web, of the expanding or deflection roller.

* * * * *