

999,879.

Patented Aug. 8, 1911.

3 SHEETS—SHEET 1.

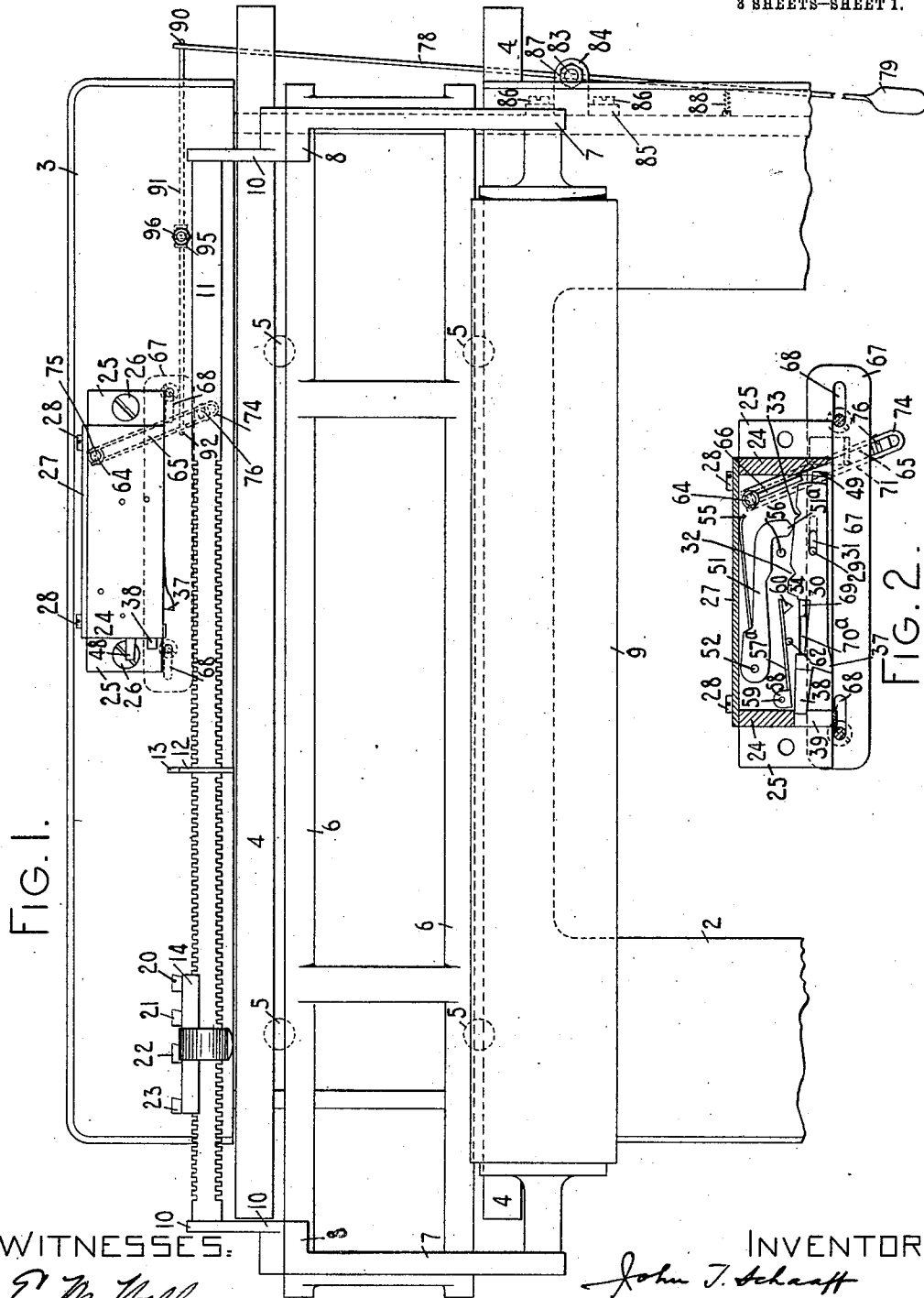

FIG. 1.

FIG. 2.

WITNESSES:  
*E. M. Miller*  
*M. W. Pool*

INVENTOR:  
*John T. Schaff*  
 By *Jacob F. Schaff*  
 HIS ATTORNEY

J. T. SCHAAFF.  
 TYPE WRITING MACHINE.  
 APPLICATION FILED FEB. 18, 1910.

999,879.

Patented Aug. 8, 1911.

3 SHEETS—SHEET 2.

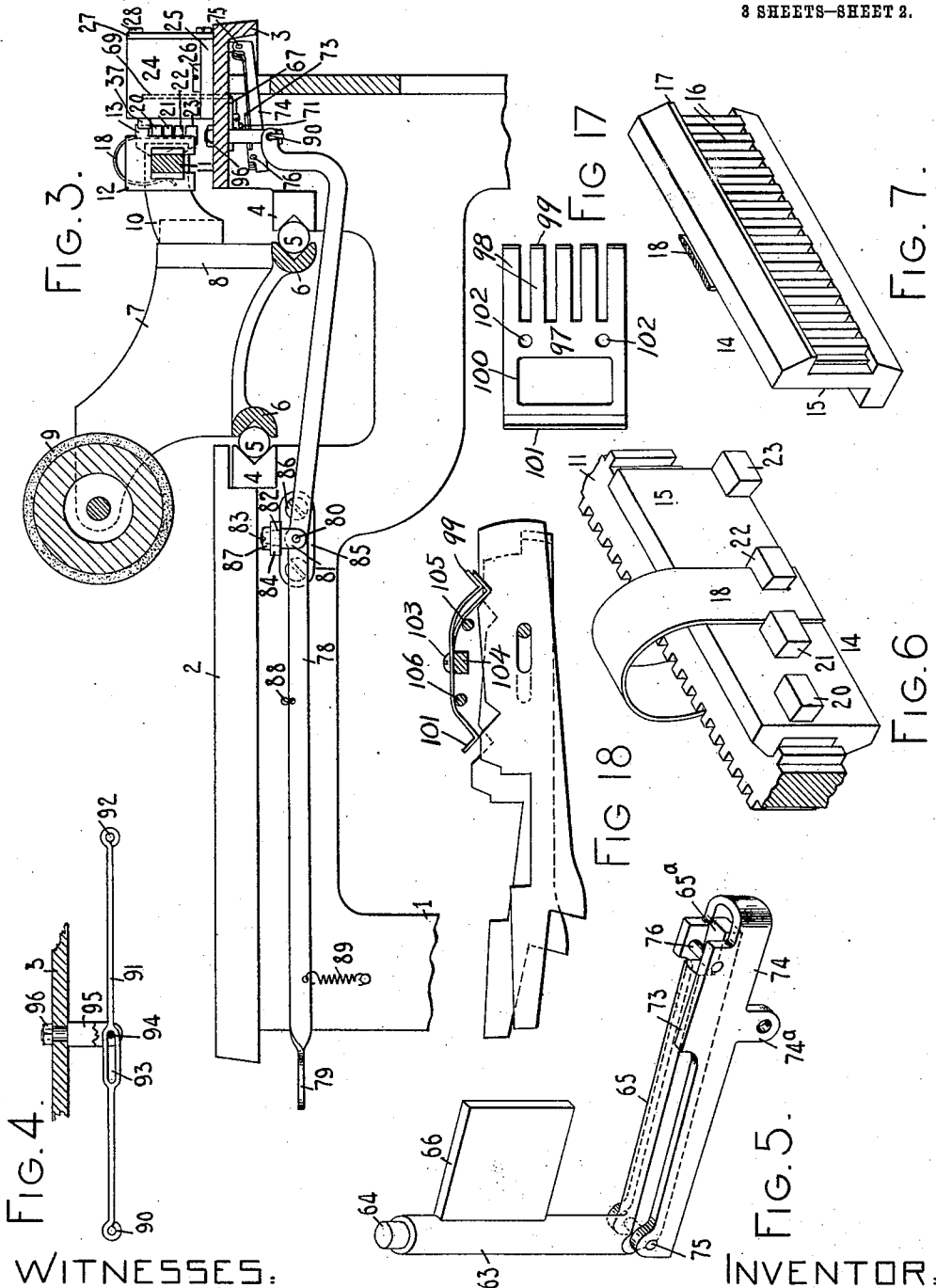

WITNESSES:  
*E. M. Wells.*  
*M. W. Pool*

INVENTOR:  
*John J. Schaff*  
 By *Jacob Felkel*  
 HIS ATTORNEY

999,879.

Patented Aug. 8, 1911.

3 SHEETS—SHEET 3.

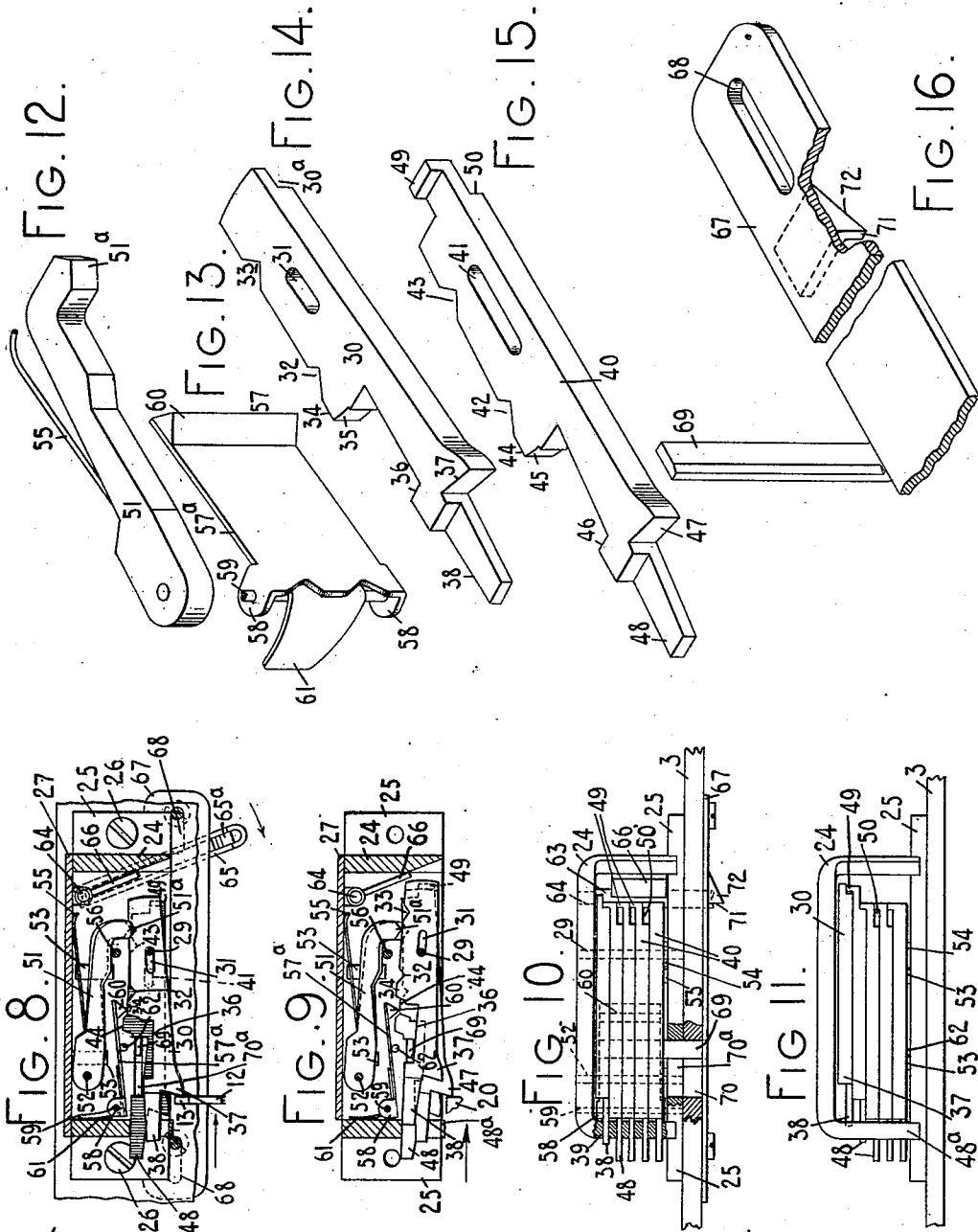

WITNESSES:

*E. M. Wells.*  
*M. W. Pool*

INVENTOR:

*John T. Schaff*  
*By Jacob Felber*

HIS ATTORNEY

# UNITED STATES PATENT OFFICE.

JOHN T. SCHAAFF, OF WASHINGTON, DISTRICT OF COLUMBIA, ASSIGNOR TO UNION TYPEWRITER COMPANY, OF ILION, NEW YORK, A CORPORATION OF NEW YORK.

TYPE-WRITING MACHINE.

999,879.

Specification of Letters Patent.

Patented Aug. 8, 1911.

Application filed February 18, 1910. Serial No. 544,560.

*To all whom it may concern:*

Be it known that I, JOHN T. SCHAAFF, citizen of the United States, and resident of Washington, in the District of Columbia, have invented certain new and useful Improvements in Type-Writing Machines, of which the following is a specification.

My invention relates more especially to stop mechanism for the traveling element or carriage of a typewriting machine and its object is to provide improved mechanism of the class specified.

To the above and other ends my invention consists in the features of construction, combinations of devices and arrangements of parts hereinafter described and particularly pointed out in the claims.

More specifically my invention has to do with stop devices which are automatically controlled so as variably to arrest the carriage and permit writing of different lines to be begun at different distances from the margin of the work sheet. In the present instance I mount on the carriage a plurality of stops which are spaced apart lengthwise of the carriage and are out of line with each other so that they travel in different paths. Each of these stops is adapted to cooperate with a particular one of a set of stops on the framework, the different members of the set being projected automatically and in a predetermined order from inoperative position into position to co-act with the associate carriage stop. As a result of the co-action between the carriage stops and the automatically operating set of frame stops, the carriage, during a series of return movements, will be variably arrested at predetermined points so as to facilitate the writing of a particular form of work requiring various lines to be begun at different points, such, for example, as the heading of letters, the addresses on envelopes and so forth. Manual devices also are provided for moving the whole set of frame stops into or out of operation and for other purposes hereinafter set forth.

The present embodiment of my invention will be more fully explained in connection with the accompanying drawings, wherein—

Figure 1 is a fragmentary plan view of a typewriting machine to which my invention is applied, only so much of said machine being shown as is necessary to a clear understanding of my said invention. Fig. 2 is a

horizontal sectional view of the stop mechanism that is mounted on the frame of the machine. Fig. 3 is a fragmentary vertical sectional view showing the upper portion of said typewriting machine. Fig. 4 is a fragmentary rear view of certain of the manually operating devices for controlling the automatic frame stops. Fig. 5 is a perspective view of parts of my mechanism. Figs. 6 and 7 are perspective views of one form of traveling or carriage stops. Figs. 8 and 9 are views corresponding to Fig. 2 but showing some of the parts in different relations. Figs. 10 and 11 are front elevations corresponding respectively to Figs. 8 and 9, parts being broken away in Fig. 10. Figs. 12 to 16 inclusive are perspective views of different elements of my improvements shown detached. Fig. 17 is a detached face view of a spring element involved in a modified construction of my invention. Fig. 18 illustrates the spring element shown in Fig. 17 in connection with associate parts.

My invention may be applied to any suitable typewriting machine, that shown in the drawings being of the front-strike variety and comprising a main frame 1 surmounted by top plate sections 2 and 3, said frame supporting fixed grooved track-ways 4 to which are adapted anti-friction balls 5, said balls also cooperating with the connected grooved bars 6 of a platen carrier or frame which further comprises end plates 7 terminating at the rear in angular portions 8. The platen frame carries a platen 9 which is equipped with suitable paper feeding and line spacing devices (not shown). It is to be understood that the machine is provided with suitable printing, inking and carriage feeding devices and other devices required to facilitate the production of typewritten matter, although it has not been deemed necessary to illustrate any of these devices in the drawings since the full import of my invention may be understood without their aid.

Arms 10 fixed to the parts 8 extend rearward therefrom and support a stop carrying bar 11, said bar being provided at its front and rear edges with teeth a letter space distance apart between which are adapted to fit traveling stop members such as 12. The stop member 12 is bifurcated to fit over the stop bar 11 and between the teeth thereof at any desired point and said stop member

12 is provided at its top with a rearwardly projecting lug or traveling stop proper 13. It will be understood that any desired number of traveling stops similar to 12 but with  
 5 stop lugs in different planes may be employed, and that these stops may be suitably adjusted along the stop bar to suit the work in hand. The present exemplification of my invention is particularly adapted  
 10 to arrest the carriage variably to write letter headings. As is well understood, such headings usually comprise a date line at the right-hand side of the sheet and four address lines, one for the name, one for the  
 15 street and number, one for the town and one for the State, these address lines usually beginning at progressively increasing distances from the left-hand margin of the sheet. Accordingly in the present instance  
 20 I prefer to employ the stop 12 to assist in determining the point of beginning of the date line and to provide a single traveling stop member 14 having several stop lugs. In the stop here shown I provide four stop  
 25 lugs, one for each line of the address. As appears from Figs. 6 and 7 the stop member 14 comprises a plate-like body portion 15, the inner face whereof is provided with a plurality of teeth 16 which are adapted to  
 30 fit over and engage with the teeth of the stop bar 11, said teeth 16 underlying a lip or ledge 17 which contacts with the top of the stop bar 11. The stop member 14 is maintained in position on said stop bar by a  
 35 spring clip 18 which is fast to the stop member and extends over the top of the stop bar 11 and downward at the front side thereof, the free end of the spring clip curving inward and engaging with the front toothed  
 40 face of stop bar 11. The rear face of the body portion 15 is provided with rearwardly extending lugs or traveling stops proper 20, 21, 22 and 23. These stop lugs, as will be understood from Figs. 1, 3 and 6, project to  
 45 the same extent rearward so that their working faces lie in a vertical plane longitudinal of the stop bar 11, but said stop lugs are stepped downward or lie in different horizontal planes so that they travel in separate  
 50 paths or planes which are parallel with the path of travel of the carriage. As best appears in Fig. 3 the stop 20 travels in a path below the stop 13 while the stops 21, 22 and 23 are respectively in successively lower planes or positions. It will further be apparent more especially from Figs. 1 and 6  
 55 that the working or contact faces of the traveling stops 20 to 23, inclusive, which faces are the right-hand vertical faces, are in different vertical planes transverse of the stop bar 11, so that said stops are adapted to  
 60 arrest the carriage at progressively varying points by contact during return movements of the carriage with the frame stops next to be described.  
 65

The frame stops in the present instance are arranged in a case or housing 24 having horizontally extending tabs 25 which receive headed screws 26 whereby the housing  
 70 is secured to the upper face of the top plate section 3. Said housing is open at its front side and is provided with a removable rear side or cover plate 27 which is secured in place by screws 28. The frame stops and  
 75 the parts immediately associated therewith are clearly illustrated in Figs. 2 and 8 to 16 inclusive while any number of stops desired may be provided in the present embodiment. There are five of these frame  
 80 stops one for each of the traveling stops and they lie one above the other, being adapted to be projected forward separately through the open side of the housing 24 and into the paths of the particular traveling  
 85 stops with which they are meant to cooperate. The frame stops which are bar-like in form are operated as levers each having a loose or sliding connection with an upright pivot pin or fulcrum rod 29 which is  
 90 secured within the housing 24 to the top and bottom thereof. The uppermost frame stop 30 is shown detached in Fig. 14. It has a longitudinally extending slot 31 for the fulcrum rod 29 and its rear face is formed with  
 95 two V-shaped notches 32 and 33 which are respectively at the left and right of the fulcrum rod. To the left of the notch 32 is a contact face 34 and a camming face 35, the rear face of the frame stop or stop bar 30  
 100 being cut away to the left of the camming face to form a notch 36. The front left-hand portion of the bar 30 is cut away to provide a contact face or stop proper 37 and a finger 38 which projects into and is adapted  
 105 to be guided by a horizontal guide slot 39 in the left-hand vertical wall of the housing 24. Similar guide slots bearing the same numeral of reference 39 are provided for the underlying frame stops. The four frame  
 110 stops or stop bars which lie one above another underneath the stop bar 30 are all alike so that a description of one will apply to all, reference being especially had to Fig. 15 wherein one of said stop bars is shown  
 115 detached and numbered 40. Said stop bar is somewhat similar to the top stop bar 30, being provided with a slot 41 for the fulcrum rod 29 and also having V-notches 42 and 43, a contact face 44, a camming face 45, a notch  
 120 46, a stop face 47 and a finger 48 which engages in one of the guide slots 39. At its right-hand end each of the stop bars 40 is provided with an extension terminating in an upwardly extending lip 49, the under  
 125 face of said extension being cut away as indicated at 50. The lip 49 of the upper one of the four stop bars 40 is adapted to cooperate with the cut-away 30<sup>a</sup> formed at the right-hand under side of the stop bar 30; while the lip 49 of each of the other stop  
 130

bars 40 coöperates with the cut-away 50 of the immediately overlying stop bar 40 as will be clearly apparent from Figs. 10 and 11. Levers or dogs 51 are arranged one above the other within the housing behind the frame stops, said levers or dogs being pivoted on a fixed upright fulcrum rod 52 so that they may move independently. There are five of these levers or dogs one for each frame stop, the set of levers being supported on lugs or ribs 53 projecting upward from the bottom of the housing so that each lever 51 is in a plane of one of the stops, the set of frame stops being also raised somewhat above the bottom of the housing by a lug 54 underlying said set at the right and coöperating with the bottom wall of the lowermost guide slot 39 to hold the lowest frame stop slightly above the bottom of the housing. The levers 51 extend rightward from their fulcrum rod and terminate each in a forwardly extending nose 51<sup>a</sup> which is beveled to coöperate with the V-notches in the rear face of the fulcrum stops. Each lever or dog 51 is provided with a wire spring 55 which reacts against the back wall of the housing and tends constantly to press its associate lever 51 forward to engage the companion frame stop. A stationary upright stop pin 56 limits the forward movements of the levers 51. These levers, as will hereinafter appear, serve both as actuators and as detents for the frame stops. There is provided an additional member 57 which coöperates with the frame stops and also combines the functions both of an actuator and a detent. Said member is shown detached in Fig. 13 and comprises a plate-like body portion 57<sup>a</sup> having angularly turned ears 58 at its left-hand side, said ears pivoting on a stationary vertical fulcrum rod 59. The member at its right-hand end is provided with a beveled nose 60 which is adapted to coöperate with the rear face of the frame stops to the left of the levers 51. The nose 60 is pressed constantly toward the frame stops by a leaf spring 61 secured to the body portion 57<sup>a</sup> and reacting against the left-hand side of the housing 24. A stop pin 62 limits the forward movement of the nose 60 by engaging the body portion 57<sup>a</sup>.

Referring to the operation of the frame stop mechanism as thus far described, let it be assumed that the parts are in the relationship shown in Fig. 8. At this time the nose of the topmost lever 51 will be seated in the notch 33 of the stop bar 30 while the nose 60 will be in coöperation with the contact face 34 to the left of the fulcrum rod 29, with which rod the right-hand end of the slot 31 is in contact. The result is that the left-hand portion or arm of the stop bar 30 will be pressed forward until arrested in the position shown by the nose 51<sup>a</sup> of the associate lever 51. In this position of the

stop bar 30 its stop face 37 will be projected forward into the path of the traveling stop 13. All of the underlying stop bars 40 are at this time held in inoperative position by their associate levers 51, the noses of said levers being in contact with the rear edges of the stop bars 40 at the right of the notches 43 therein so that the lever springs 55 are operating to press the right-hand portions or arms of the stop bars 40 forward, the left-hand arms or portions of said stop bars being retracted within the housing and being arrested by contact with the rear walls of their associate guide slots 39. At this time it will be noted that the nose 60 is opposite the cut-outs or notches 42 in the stop bars 40 but is held out of contact therewith by reason of its engagement with the contact face 34. Assuming that a suitable work sheet has been introduced into the machine and positioned on the platen to receive the first line of writing, which in the present instance it will be recalled is the date line at the top of a letter; and assuming further that the platen and platen carrier are positioned as shown in Fig. 1, then the operator will retract the carriage rightward by hand in the usual manner, bringing the stop lug 13 into contact with the projected stop face 37, as shown in Fig. 8. Thereafter as rightward movement of the platen carriage and stop 13 continues, said stop will force the stop bar 30 longitudinally rightward until the same is arrested by the left-hand end of stop bar 30 coming in contact with the right-hand wall of housing 24. During this rightward movement of the stop bar 30 the nose 51<sup>a</sup> will be forced rearward out of the slot 33 and will slide along the rear face of the stop bar to the left of said notch; while the contact face 34 will pass beyond the nose 60. As soon as this occurs the spring 55 of the associate lever 51, acting through the nose thereof, will tend to force the right-hand arm of the stop bar 30 forward and retract the stop face 37 within the housing. This action, however, will be prevented by the engagement of the stop 13 with said stop face, which latter may be slightly inclined to facilitate its being held against retraction; and if found desirable the stop 13 may be correspondingly inclined. During the rightward longitudinal movement of the stop bar 30 the vertical wall of the cut out 30<sup>a</sup> therein will engage with the lip 49 of the contiguous stop bar 40 and will slide said stop bar 40 longitudinally rightward, bringing the notch 43 into register with the nose of the associate lever 51, and the contact face 44 into engagement with the nose 60. The result will be that the spring 61 will force the left-hand arm of the stop bar 40, which is the topmost of the set, forward so as to project its stop face 47 into operative position. After the carriage has been arrested in its

rightward movement by the stop 37 the writing in of the date may be proceeded with, the coacting stops 37 and 13 of course having arrested the carriage in proper position to begin the writing. During the writing the carriage will move leftward and the stop 13 will move with it out of contact with the stop face 37, permitting said stop face to be retracted within the housing by the associate spring 55 as above explained. The position of the parts at this time is shown in Fig. 9 from which it will be perceived that the stop face 37 is inoperative while the stop face 47 of the topmost stop bar 40 has been projected forward into position to cooperate with the associate traveling stop 20 during the next retraction of the carriage. When the carriage is arrested by the cooperation of this projected stop face 47 and the stop 20, it will be in position to begin the printing of the name line of the address, which is the top line thereof. During the second retraction of the carriage and after the engagement of the stop lug 20 with the projected stop face 47, the associate stop bar 40 will be slid longitudinally rightward with the result that the nose of the associate lever 51 will be forced out of the notch 43 and will act against the rear face of the arm 40 to the left of said notch to force the right-hand arm of the stop bar 40 forward and retract the stop face 47, which operation will occur as soon as said stop face is released from the lug 20, by reason of the fact that the contact face 44 has passed the nose 60. The longitudinal rightward movement of the uppermost stop bar 40 will bring the vertical face of the cutaway 50 therein against the lip 49 of the immediately underlying or second stop bar 40 and will force said second stop bar rightward, with the result that its stop face 47 will be projected forward, as hitherto explained, into position for cooperation with the stop lug 21. Consequently during the third retraction of the carriage it will be arrested in position for beginning the second line of the address by reason of the engagement of the stop lug 21 with the projected stop 47 of the second stop bar 40; and these two engaged stops will cooperate in a manner similar to that above outlined to effect the projection of the immediately underlying, or third, stop face 47 for engagement with the stop lug 22. Similarly the stop face 47 of the lowest, or fourth, stop bar 40 will be projected in turn and after arresting the carriage in position for writing the last line of the address will be retracted within the housing so that the carriage will be left free to travel back and forth to the full extent between the usual margin stop devices (not shown) during the writing of the body of the letter.

In order to reset the frame stops in the Fig. 8 position when it is desired to begin

the address at the top of a new letter, devices are provided comprising a rock shaft 63 (Fig. 5) which takes bearings in the top and bottom walls of the housing, the upper end of said rock shaft being reduced as indicated at 64 (Fig. 5) to prevent longitudinal upward movement. The rock shaft extends downward through a hole in the top plate section 3 and is provided with an angular arm or crank 65 which extends forward under the said stop plate section. Within the housing and to the right of the ends of the stop bars 40 a broad retracting plate or finger 66 is secured to the rock shaft, the lower edge of said plate being adapted to engage the bottom of the housing and prevent downward longitudinal movement of the rock shaft 63. When the crank arm 65 is swung leftward in the direction of the arrow in Fig. 8 it will rock the shaft 63 and cause the finger 66 to engage with the ends of the stop bars 40 behind the lips 49 thereon and to move said stop bars together to the position shown in Fig. 8. From Fig. 10 it will be noted that the finger 66 is not high enough to engage with the stop bar 30, which consequently will not begin to move leftward until the vertical wall of the cutaway 30<sup>a</sup> is engaged by the underlying lip 49. Therefore the stop bar 30 will have a less extent of leftward movement than the underlying stop bars 40 and will stop in the Fig. 8 position with the stop face 37 projected forward in operative position and ready for the next cycle of automatic operations to be begun.

Associated with the setting devices comprising the rock shaft 63 are devices for rendering the automatic frame stops inoperative at pleasure so as to avoid the necessity of completing the regular cycle of operations, in case, for example, the address should consist of a less number of lines than four. The retracting devices above referred to comprise a slidable plate 67 which is shown detached in Fig. 16, said plate being formed with longitudinal slots 68 which receive headed screws whereby the plate is maintained close to the under side of the top plate section 3 and so that it may be slid back and forth therebeneath on said screws. Said plate has an upright finger 69 which passes through a slot 70 in the top plate section 3 and through a corresponding slot 70<sup>a</sup> in the bottom of the housing. The finger 69 is located in the notches or cutaways 46 and 36 so that when the plate 67 is slid rightward said finger will engage with the right-hand walls of said notches and will move all of the frame stops together rightward to inoperative position. Separable connections are provided between the crank arm 65 and the plate 67, said connections comprising an angular arm having a vertical stop face 71

extending down from the under side of said plate, and having also an inclined edge 72 (Fig. 16). Cooperative with the lug or stop 71 is an engaging lug 73 which as shown clearly in Fig. 5 is an upward extension or lug formed on a U-shaped member 74 which embraces the crank arm 65 and is pivoted thereto at 75 so as to have a limited independent movement up and down thereon, said member 74 being held in normal relation with said crank arm by a cross pin 76 which contacts with the top of a cutaway 65<sup>a</sup> at the forward end of said crank arm. During the leftward swings of the crank arm, the lug 73 will either pass under or slide over the inclined edge 72 without affecting the plate 67 and finger 69; and during rightward swings of said crank arm so long as the member 74 remains down in normal position thereon as shown in Figs. 3 and 5, the plate 67 will not be affected for the reason that the lug 73 will pass under the device 71, as clearly appears from Fig. 3. If, however, during rightward swings of the crank arm the member 74 be swung up or lifted on its pivot 75 to bring the lug 73 in the plane of the engaging device 71, then the plate 67 will be taken up and the finger 69 will act on the stop bars 30 and 40 to retract them as above explained.

In order conveniently to operate the setting finger 66 and the retracting finger 69 from the front of the machine, I provide connections from the crank arm 65 and the member 74 to a lever 78 which extends fore and aft of the machine and is provided with a finger piece 79 projecting forward from beneath the top plate at the right-hand side of the machine (Figs. 1 and 3). The lever is fulcrumed at 80 on a swivel 81, said swivel being provided with a shouldered portion 82 and a reduced threaded portion 83. The shouldered portion bears in the overhanging arm 84 of a bracket 85 secured by screws 86 to the frame of the machine, said swivel being maintained in place on the bracket by a nut 87 which is screwed on the threaded portion 83 until it abuts the shoulder 82. The construction is such that the swivel may turn freely on the bracket, thereby giving rotary horizontal movements to the lever 78 while the lever may also swing on its fulcrum 80 in vertical planes independently of the swivel. A coiled spring 88 is connected to the frame work and to the forward arm of the lever 78 and tends constantly to draw the forward arm toward the left, maintaining it normally set in the position shown in Fig. 1. A second coiled spring 89 also connected to the frame-work and to the forward arm of the lever 78, tends constantly to draw the forward arm downward and raise the rear arm of said lever. Said rear arm has an upward ex-

ension which is pivotally connected at 90 with a member 91 which has the functions both of a link and a lever, said member being pivotally connected at its inner end at 92 with a downwardly extending lug 74<sup>a</sup> (Fig. 5) on the member 74. As best shown in Fig. 4 the member 91 is formed with an elongated slot 93 which cooperates with a pivot pin 94 carried by a swivel 95, said swivel bearing in an opening in the top plate section 3 and being held in place by a nut 96. The construction is such that the member 91 may turn on the pin 94 as a fulcrum independently of the swivel and may also slide longitudinally as a link; while said member may also turn together with the swivel 95 in substantially horizontal planes beneath the top plate.

The manual devices above described may be actuated to set the frame stops for operation or to retract them out of operative position. By merely pressing the finger piece 79 horizontally rightward the member 91 is forced longitudinally inward and operates to swing the crank arm 65 leftward, causing the finger 66 to set the frame stops in the Fig. 8 position, after which the finger piece may be released, permitting the manual devices to be restored to normal position by the spring 88. If at any time during the cycle of automatic operations of the frame stops it be desired to render the entire set inoperative, the finger piece 79 may be swung horizontally outward, thereby swinging the stop 73 to the left of the stop 71. Next the finger piece 79 is lifted, lowering the rear arm of the lever 78 and swinging the inner arm of the member 91 upward, thereby raising the stop 73 into the plane of the stop 71; after which the finger piece 79 is swung back to normal position, the finger piece 79 being held raised during such swinging back movement. As a result thereof the stop 73 will engage with the stop 71 and slide the plate 67 rightward to the Fig. 2 position, causing the finger 69 to retract the entire set of frame stops to inoperative position as shown in said Fig. 2.

Various changes may be resorted to without departing from the spirit and scope of my present invention. An example of such changes is illustrated in the modified construction shown in Figs. 17 and 18. In this modified construction the set of levers 51 and the member 57 are replaced by a single element which is shown detached in Fig. 17 and numbered 97. Said member 97 is made of sheet metal which is cut out to provide a set of spring tongues 98, each of which terminates in an angular portion 99, thus providing a beveled end on each tongue 98 corresponding to the noses 51<sup>a</sup> of the levers or dogs 51 which levers the spring tongues 98 replace. The member 97 has a slot 100 to reduce the stiffness of the metal and the

end of the member opposite from the spring tongues is bent as indicated at 101, thus providing a beveled portion or V-rib corresponding to the nose 60 of the prior construction. The member 97 is provided with holes 102 which receive screws 103, said screws securing said member 97 to a stationary upright standard 104 within the housing 24. Vertical stop pins 105 and 106 cooperate with the member at opposite sides of the standard 104 to limit forward movement of respectively the spring tongues 98 and the beveled portion or V-rib 101. The inherent spring of the metal tends constantly to maintain the tongues 98 and V-ribs 101 forward in contact with their stop pins 105 and 106. It will be understood that the spring tongues and the V-rib portion 101 are adapted to cooperate with the slots 33 and 32 in the stop bar 30 and also with the slots 43 and 42 in the stop bars 40, performing the same functions as the elements which the member 97 replaces in the prior construction.

Besides the changes above referred to various other changes may be resorted to within my invention.

It will be noted that by my present invention I combine a carriage, stops thereon, a set of cooperating stops arranged in planes registering always with said first named stops, and means for automatically operating a plurality of said set of cooperating stops so as to render them operative one at a time by projecting them in predetermined order into the paths of the stops on the carriage with which they are adapted to co-act, said plurality of stops being normally out of the paths of their co-acting stops on the carriage; that the set of cooperating stops as a whole is movable back and forth by hand-controlled means; that the stops on the carriage are adjustable therealong, and their contact faces travel in separate and distinct paths; that the cooperating stops, which are mounted on the machine frame and may be termed frame stops, are in the nature of margin stops which are combined with automatic means for bringing them into working relationship with their associate co-acting stops on the carriage so as to vary the marginal point at which the carriage is arrested during successive return movements; that hand mechanism is provided for setting the cooperating stops for cooperation, means being provided which operate thereafter automatically to move the set of stops back and forth one at a time, the automatic means operating through the stop first projected by said hand mechanism; that devices controlled by said hand mechanism act to render said set of stops inoperative, said devices comprising a slidable plate provided with an upright finger, said devices and said hand mechanism together comprising manual means for setting said

set of stops for operation and for retracting all of said set of stops at pleasure to inoperative position; that a plurality of stops on the carriage are arranged in different planes and have unvarying paths of movement in said planes, these stops co-acting with a plurality of a set of cooperating stops each being movable by automatic means in a different plane corresponding to the plane in which one of the stops on the carriage is movable; and that the cooperating stops are manually movable back and forth in different planes while automatic means are adapted to move said cooperating stops in the same planes, the automatic movement being at substantially right angles to the directions in which the manual movements take place.

What I claim as new and desire to secure by Letters Patent, is:—

1. In a typewriting machine, the combination of a carriage, a plurality of stops arranged in different planes, a plurality of cooperating stops arranged in planes registering always with said first named stops, and means operating automatically to put said pluralities of stops in cooperative relationship.

2. In a typewriting machine, the combination of a carriage, a plurality of stops arranged in different planes, a plurality of cooperating stops arranged in planes registering with said first named stops, but normally out of the path thereof, and means operating automatically to project said cooperating stops into and out of the paths of said first named stops.

3. In a typewriting machine, the combination of a carriage, a plurality of stops arranged in different planes, a plurality of cooperating stops arranged in planes registering with said first named stops but normally out of the path thereof, and means operating automatically to project said cooperating stops one at a time into and out of co-acting position.

4. In a typewriting machine, the combination of a carriage, a plurality of stops adjustable thereon, the contact faces of said stops traveling in separate and distinct paths, a plurality of frame stops one for each of said plurality of traveling stops, and means for automatically projecting the frame stops one at a time into and out of the paths of their associate traveling stops.

5. In a typewriting machine, the combination of a carriage, a plurality of margin stops, a plurality of co-acting stops, and automatic means for bringing said margin stops into working relationship with their associate co-acting stops.

6. In a typewriting machine, the combination of a carriage, a plurality of separately movable margin stops, a plurality of co-acting stops, and automatic means for

moving the margin stops one at a time into working relationship with said associate co-acting stops.

7. In a typewriting machine, the combination of a carriage, a plurality of separately movable margin stops, a plurality of co-acting stops, and means acting automatically during successive return movements of the carriage to move the margin stops in predetermined order one at a time into working relationship with their associate co-acting stops on the carriage so as to arrest the carriage variably during successive return movements.

8. In a typewriting machine, the combination of a carriage, a plurality of stops arranged in different planes, a plurality of co-operating stops arranged in planes registering with said first named stops, and means operating automatically to move said co-operating stops into and out of operative position in predetermined order.

9. In a typewriting machine, the combination of a carriage, stops arranged in different planes, a set of co-operating stops arranged in planes registering with said first named stops, hand mechanism for setting said set of stops for operation, and means for thereafter automatically moving said set of stops back and forth one at a time.

10. In a typewriting machine, the combination of a carriage, stops arranged in different planes, a set of co-operating stops arranged in planes registering with said first named stops, hand mechanism for projecting one of said set in operative position, and automatic means operating through said projected stop to project the other members of said set successively into operative positions.

11. In a typewriting machine, the combination of a carriage, stops arranged in different planes, a set of co-operating stops arranged in planes registering with said first-named stops, hand mechanism for setting said set of stops for operation, means for thereafter automatically moving said set of stops back and forth one at a time, and devices controlled by said hand mechanism for rendering said set of stops inoperative.

12. In a typewriting machine, the combination of a carriage, a plurality of stops arranged in different planes, a set of co-operating stops arranged in planes registering with said first-named stops, and manual means for setting said set of stops for operation and for retracting all of said set of stops at pleasure to inoperative position.

13. In a typewriting machine, the combination of a carriage, a plurality of stops arranged in different planes and having unvarying paths of movement in said planes, a plurality of co-operating stops each movable in a different plane corresponding to the plane in which one of the first-named stops

is movable, and means operative automatically to bring said stops into co-action.

14. In a typewriting machine, the combination of a carriage, a plurality of stops each movable in a different plane, a plurality of co-operating stops each movable in a different plane corresponding to the plane in which one of the first-named stops is movable, and means operative automatically to bring said stops into co-action one after another in predetermined order.

15. In a typewriting machine, the combination of a carriage, a plurality of stops arranged in different planes, a plurality of co-operating stops arranged in planes registering with said first named stops, manual means for moving said co-operating stops back and forth, and automatic means for moving said co-operating stops back and forth in a different direction.

16. In a typewriting machine, the combination of a carriage, a plurality of stops, a plurality of co-operating stops, manual means for moving said co-operating stops back and forth in different planes, and automatic means for moving said co-operating stops in the same planes.

17. In a typewriting machine, the combination of a carriage, a plurality of stops, a plurality of co-operating stops, manual means for moving said co-operating stops back and forth in different planes, and automatic means for moving said co-operating stops in the same planes at substantially right angles to the directions in which said stops are moved by said manual means.

18. In a typewriting machine, the combination of a carriage, a plurality of stops, a plurality of co-operating stops, and means for causing said co-operating stops to operate one on another to render said other operative.

19. In a typewriting machine, the combination of a carriage, a plurality of stops, a plurality of co-operating stops, and means for causing said co-operative stops to operate one on another in a predetermined order so as to render certain of said co-operative stops successively operative.

20. In a typewriting machine, the combination of a carriage, a plurality of stops, a plurality of co-operating stop levers, and means for automatically swinging said stop levers on their fulcrums into and out of operative position.

21. In a typewriting machine, the combination of a carriage, a plurality of stops, a plurality of co-operating stop levers arranged in parallel planes, and means for automatically moving said stop levers into position to co-operate with said stops to variably arrest the carriage.

22. In a typewriting machine, the combination of a carriage, a stop, a co-operating stop lever, and automatic means operating

alternately on opposite sides of the fulcrum of said lever to swing it to and fro in its fulcrum into and out of position to co-act with said stop.

5 23. In a typewriting machine, the combination of a carriage, a plurality of stops, a plurality of slidable cooperating stop levers, automatic means for causing said stop levers to slidably move one another, and  
10 means for swinging said levers independently on their fulcrums.

24. In a typewriting machine, the combination of a carriage, a plurality of stops, a plurality of pivoted and slidable cooperating stops, means for sliding said stops simultaneously back and forth in opposite directions, and means for swinging said stops separately in different directions from those in which said stops slide.

20 25. In a typewriting machine, the combination of a carriage, stops, a set of pivoted cooperating stops, spring means adapted to act on said pivoted stops on opposite sides of their pivots, and means for rendering the  
25 spring means operative at opposite sides of said pivots in alternation.

26. In a typewriting machine, the combination of a carriage, stops, pivoted and slidable cooperative stop bars, means for moving  
30 said stop bars endwise, and spring means for moving said stop bars pivotally.

27. In a typewriting machine, the combination of a carriage, a plurality of stops, cooperative stop bars each provided with a  
35 notch, and spring-pressed levers one for each stop bar, said levers having noses engageable with said notches and said stop bars being movable to bring said notches into and out of engagement with said noses.

40 28. In a typewriting machine, the combination of a carriage, a plurality of stops, cooperative stop bars each provided with a notch, spring-pressed moving levers one for each stop bar, said levers having noses  
45 engageable with said notches and said stop bars being movable to bring said notches into and out of engagement with said noses, and a spring-pressed member engageable with said stop bars to move the same.

50 29. In a typewriting machine, the combination of a carriage, a plurality of stops, cooperative stop bars each provided with a notch, spring-pressed levers one for each stop bar, said levers having noses engageable  
55 with said notches and said stop bars being movable to bring said notches into and out of engagement with said noses, and a spring-pressed member having a nose also engageable with said stop bars, said stop  
60 bars being slidable to render said noses operative on each stop bar at different times.

30. In a typewriting machine, the combination of a carriage, a plurality of stops, cooperative stop bars each provided with a  
65 notch, spring-pressed levers one for each

stop bar, said levers having noses engageable with said notches and said stop bars being movable to bring said notches into and out of engagement with said noses, and a spring-pressed member also engageable  
70 with said stop bars, said stop bars being slidable to cause said levers and said member to reciprocate said stop bars pivotally.

31. In a typewriting machine, the combination of a carriage, stops, a plurality of  
75 cooperative stops, and means for moving simultaneously said plurality of cooperative stops, said means comprising a pivotally mounted finger, a hand lever, and connections between said hand lever and said finger, said finger being normally disconnected  
80 from said stops.

32. In a typewriting machine, the combination of a carriage, stops, cooperative stops, means for moving said cooperative stops in  
85 one direction, said means comprising a pivotally mounted finger, a hand lever, and connections between said hand lever and said finger, and means for moving said cooperative stops in the opposite direction, said  
90 last recited means comprising a slidable member, and engageable lugs controlled by said hand lever.

33. In a typewriting machine, the combination of a carriage, stops, cooperative stops,  
95 and means for moving said stops in one direction, said means comprising a slidable plate having a lug thereon, a member on a pivotal support, said member carrying a lug and being adapted to swing independently  
100 of said support to bring said lug into the path of said first-named lug.

34. In a typewriting machine, the combination of a carriage, stops, cooperative stops,  
105 means for moving said stops in one direction, said means comprising a slidable plate having a lug thereon, a member on a pivotal support, said member carrying a lug and being adapted to swing independently of said support to bring said lug into the  
110 path of said first-named lug, and hand means for controlling said member, said hand means comprising a lever mounted on a swivel.

35. In a typewriting machine, the combination of a carriage, stops, cooperative stops,  
115 means for moving said stops in one direction, said means comprising a slidable plate having a lug thereon, a member on a pivotal support, said member being adapted to swing independently of said support and to co-act with said lug, and hand means for controlling said member, said hand means comprising a lever mounted on a swivel and  
120 a second member slidably and pivotally mounted on a second swivel and connected with said lever.

36. In a typewriting machine, the combination of a carriage, stops, cooperative stop bars overlying one another, certain of said  
130

stop bars being provided with devices for moving certain other of said stop bars automatically during the travel of the carriage.

37. In a typewriting machine, the combination of a carriage, carriage stops thereon arranged in different horizontal planes, a set of cooperative stop bars arranged one on top of another each in the plane of one of said carriage stops, and lugs on certain of said stop bars adapted to move certain other of said stop bars.

38. In a typewriting machine, the combination of a carriage, carriage stops thereon arranged in different horizontal planes, a set

of cooperative stop bars, means on certain of said stop bars to move certain other of said stop bars for rendering them operative one at a time, and hand operated means for moving said set of stop bars together back and forth.

Signed at Bridgeport, in the county of Fairfield, and State of Connecticut, this 15th day of February A. D. 1910.

JOHN T. SCHAAFF.

Witnesses:

J. NAIRN,  
EDITH MILLER.

---

Copies of this patent may be obtained for five cents each, by addressing the "Commissioner of Patents, Washington, D. C."

---