

L. PAULERO.
ELECTRIC IMPLEMENT.
APPLICATION FILED AUG. 29, 1912.

1,128,036.

Patented Feb. 9, 1915.

2 SHEETS—SHEET 1.

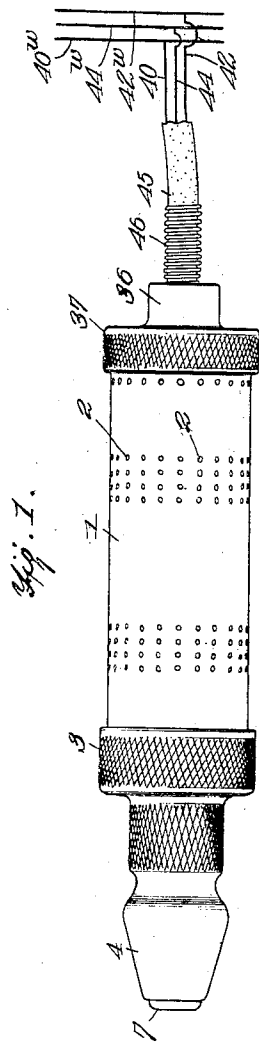
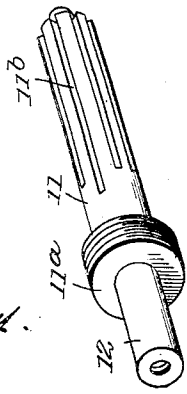

Fig. 1.

Fig. 7.



WITNESSES

L. H. Schmidt.
L. F. Stanley

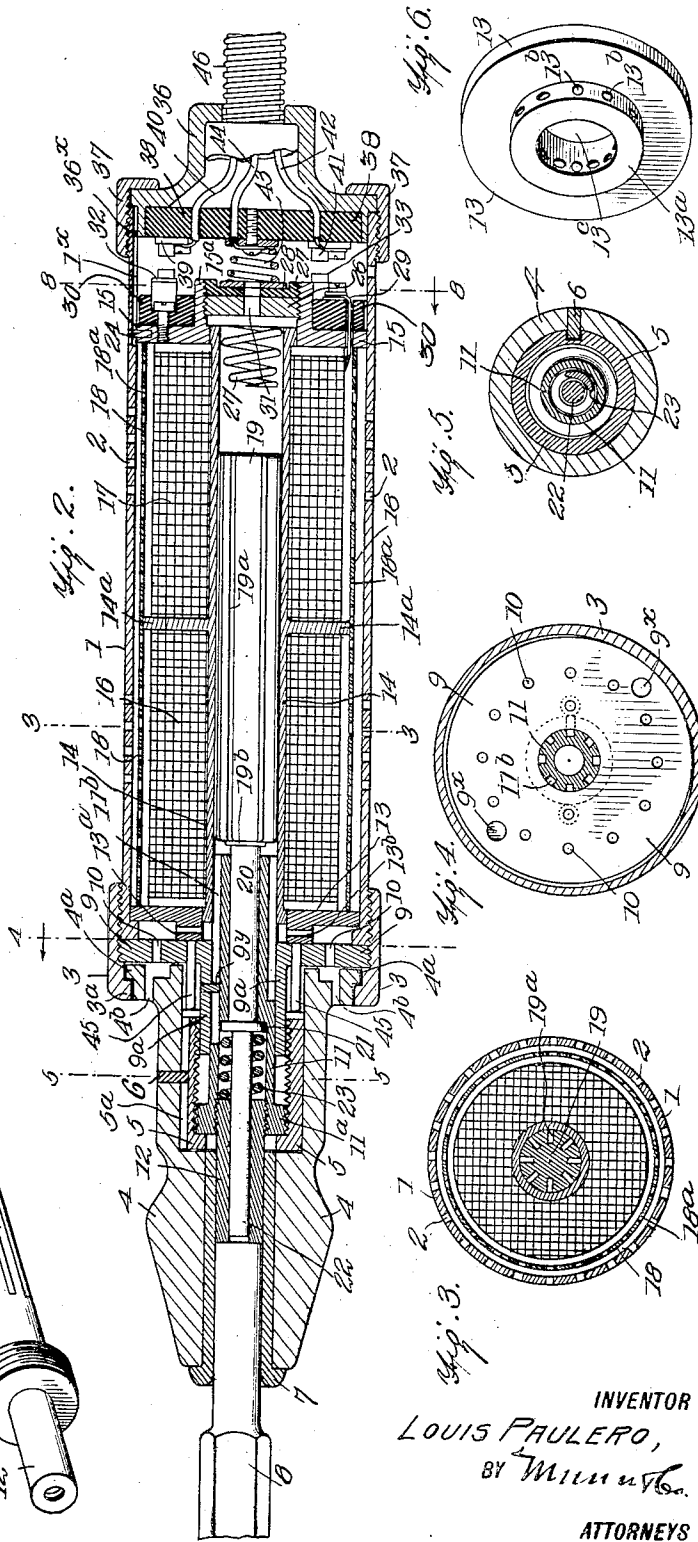

Fig. 6.

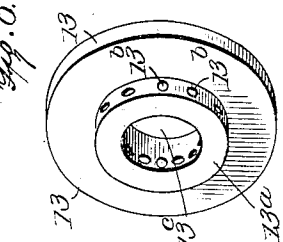

Fig. 5.

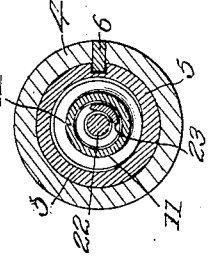

Fig. 4.

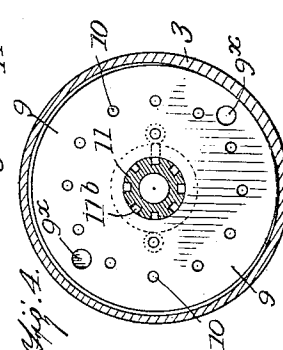
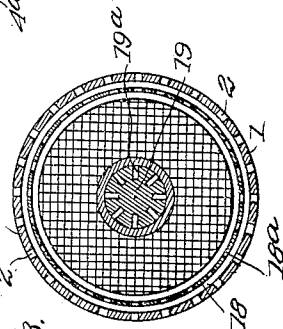

Fig. 3.



INVENTOR
LOUIS PAULERO,
BY *Munn & Co.*
ATTORNEYS

L. PAULERO.
 ELECTRIC IMPLEMENT.
 APPLICATION FILED AUG. 29, 1912.

1,128,036.

Patented Feb. 9, 1915.

2 SHEETS—SHEET 2.

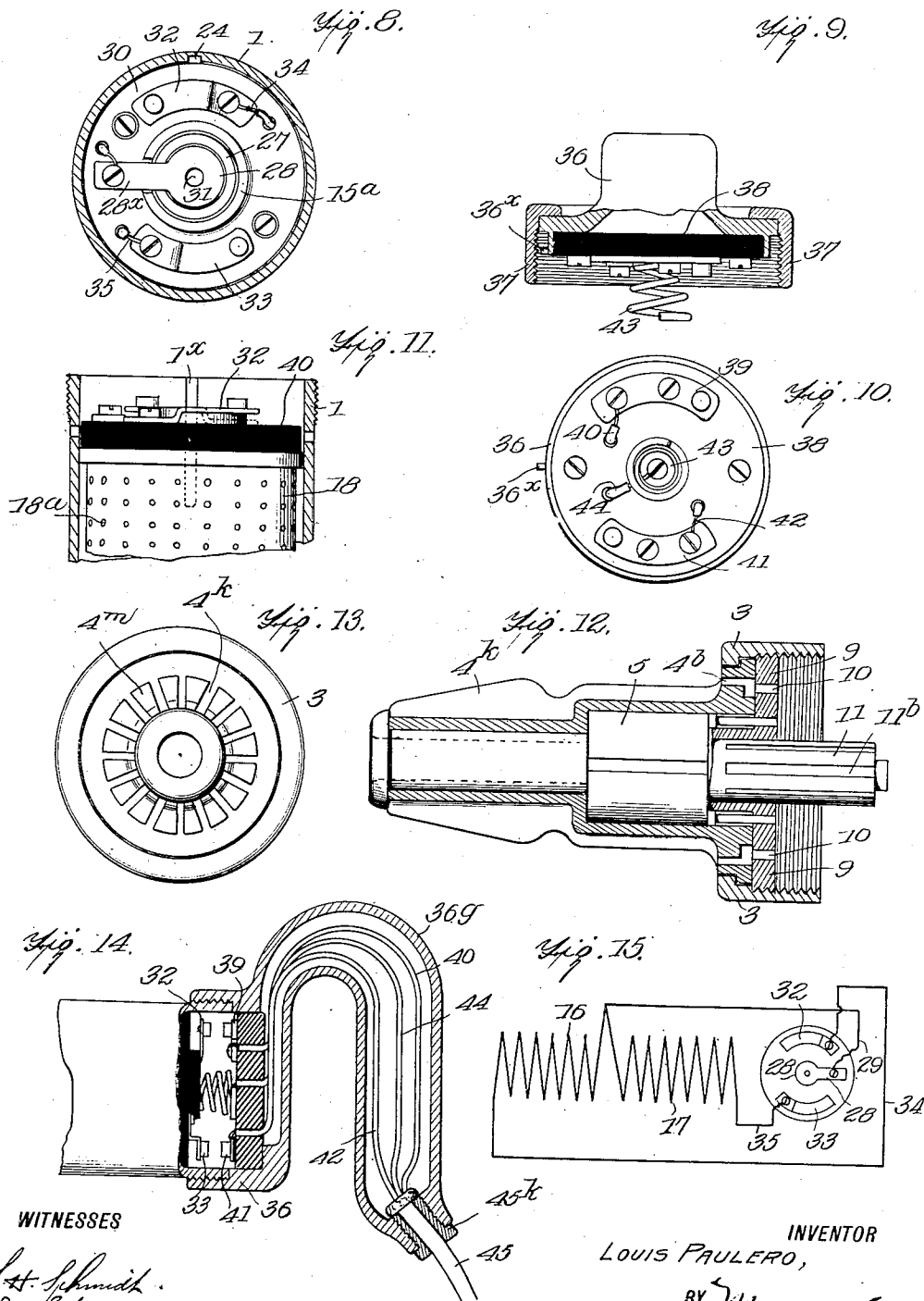

WITNESSES

L. H. Schmidt.
 L. A. Stanley

INVENTOR
 LOUIS PAULERO,
 BY *Munn & Co.*
 ATTORNEYS

UNITED STATES PATENT OFFICE.

LOUIS PAULERO, OF PETERSBURG, VIRGINIA.

ELECTRIC IMPLEMENT.

1,128,036.

Specification of Letters Patent.

Patented Feb. 9, 1915.

Application filed August 29, 1912. Serial No. 717,697.

To all whom it may concern:

Be it known that I, LOUIS PAULERO, a citizen of the United States, and a resident of Petersburg, in the county of Dinwiddie and State of Virginia, have invented certain new and useful Improvements in Electric Implements, of which the following is a specification.

My invention relates to improvements in electrically operated implements, and it consists in the combinations, constructions and arrangements hereinafter described and claimed.

An object of my invention is to provide a device especially adapted for cutting and carving stone, driving rivets, chipping and calking, hammering, and in fact wherever it is desirable to employ a tool having a reciprocating motion.

A further object of my invention is to provide an electrically operated implement of the type mentioned with novel means for closing and opening the actuating circuit so as to allow for the economical operation of the tool.

A further object of my invention is to provide a special grip for the hand of the operator using the tool, this grip inclosing the mechanism for making the various adjustments to the stroke of the plunger.

Other objects and advantages will appear in the following specification and the novel features of the device will be particularly pointed out in the appended claims.

My invention is illustrated in the accompanying drawings forming part of this application in which similar reference characters indicate like parts in the several views and in which:—

Figure 1 is a side view of the device; Fig. 2 is a longitudinal section thereof; Fig. 3 is a section along the line 3—3 of Fig. 2; Fig. 4 is a section along the line 4—4 of Fig. 2; Fig. 5 is a section along the line 5—5 of Fig. 2; Fig. 6 is a perspective view of an end plate; Fig. 7 is a perspective view of a portion of the stroke adjusting mechanism; Fig. 8 is a sectional view on the line 8—8 looking in the direction of the arrow; Fig. 9 is a sectional view of the rear end of the tool and the ring for securing it to the main body portion; Fig. 10 is a face view of the means for securing the terminals of the cable; Fig. 11 is a sectional view showing a portion of the cylinder which carries the solenoid coils; Fig. 12 is a sectional view showing a modified form

of the tool; Fig. 13 is a front view of the form shown in Fig. 12; Fig. 14 is a sectional view through a handle which forms a portion of the modified form; and, Fig. 15 is a diagrammatic view showing the circuit connections for the solenoids.

Referring now particularly to Figs. 1 and 2 I have shown therein an exterior cylindrical casing 1 which is preferably made of aluminum for the sake of lightness and which is provided with perforations 2. One end of this casing is threaded, to receive a cap 3. The latter is provided with an inwardly turned flange 3^a at its end arranged to engage the outwardly turned flange 4^a of the chuck casing 4. Openings 4^b are provided in the flange portion 4^a of the chuck casing for the purpose of ventilation, as will be explained later. The member 4 is also preferably made of aluminum. Within the chuck casing 4 is disposed a rotatable member 5 which is provided with a longitudinal groove 5^a. A pin 6 of hardened steel or other suitable material is carried by the chuck member 4 and projects into the groove for the purpose of causing the member 5 to turn on its axis when the chuck member 4 is turned by hand. A bushing 7 of hardened steel is driven into one end of the chuck member 4 and forms a socket for the tool 8. Disposed between the end of the casing 1 and the flange 4^a of the member 4 is a plate 9 which is perforated at 10. This plate has a lateral cylindrical extension 9^a on one side thereof. As will be seen from Fig. 2 the periphery of the plate 9 is threaded to engage the threads of the cap 3. When this plate 9 is screwed into the cap where it is held by means of the casing 1, the member 4 may be easily revolved by hand. As shown in Fig. 4 the plate 9 is provided with two wrench holes 9^x by means of which the plate is screwed in place. A cylindrical member 11 is disposed within the extension 9^a of the plate 9 and is provided with a head 11^a arranged to be screwed to the threaded portion of the interior of the rotatable member 5. The member 11 is provided with a longitudinal recess 11^b into which a pin 9^y carried by the cylindrical extension 9^a of the plate 9 extends. This pin 9^y prevents the rotation of the member 11 around its axis but permits the latter to have a longitudinal movement in the direction of its axis. The head 11^a of the member 11

is provided with a threaded recess arranged to receive a cylindrical member 12. Near one end of the cylinder 1 is a plate 13, which has a cylindrical extension 13^a on one side thereof provided with a series of radially extending ventilating openings 13^b. This plate 13 is best shown in Fig. 6. It has a central opening 13^c into which one end of a spool 14 extends. The latter is provided with a radially extending flange 14^a. At the opposite end of the spool 14 is a plate 15, which forms one end of the spool. Two coils 16 and 17 are wound on the spool the partition flange 14^a separating these coils. Between the coils 16 and 17 and the outer casing 1 is a casing 18 which is preferably made of thin sheet iron or other magnetic material and which is perforated with air holes 18^a. In the interior of the spool 14 is disposed a slidable plunger 19 which is provided with a series of longitudinal grooves 19^a and has at one end a reduced portion 19^b which forms a striking head arranged to engage the striking pin 20. The latter is provided with a flange 21 and has a reduced portion 22 arranged to enter the member 12. Surrounding the portion 22 and disposed between the flange 21 and the end of the member 12 is a spiral spring 23. Referring now to the plate 15, it will be seen that I have provided a pin 24 which is arranged to slide in a groove 1^x in the casing 1. This is for the purpose of preventing the solenoid from being turned on its axis and furthermore for centering the plate 15. The latter it will be observed has an extension 15^a which is threaded internally and which is arranged to receive a nut 26. A cushion spring 27 is disposed within the interior of the spool 14, one end of this spring bearing on the nut 26. The latter is provided with an insulating washer 27 which is recessed to receive a contact 28. The contact has a laterally extending portion 28^x (see Fig. 8) which is connected by means of a conductor 29 with the coils 16 and 17, (see Fig. 15) the conductor 29 passing through the insulating disk 30 which is carried by the extension 15^a and which is in contact with the plate 15. The members 26, 27 and 28 are provided with a central opening 31 for purposes of ventilation. On the plate 15 are mounted a pair of contact members 32 and 33 respectively. (See Figs. 2 and 8). The former is connected to one end of the coil 16 by means of the conductor 34, while the contact 33 is connected with the coil 17 by means of the conductor 35. At one end of the device is an end piece 36 which is held by means of a screw cap 37, the latter being arranged to engage the threaded portion of the cylinder or casing 1. The end member 36 carries an insulating plate 38 upon which is mounted a contact

member 39 to which is connected a lead wire 40. A contact member 41 is connected to a lead wire 42, while a central contact member 43 is connected to a lead wire 44. These leads pass through the insulating member 38 and out through the flexible connection 45 shown in Fig. 1, the wires being suitably insulated from the end member 36. The contact member 43 is in this instance a spiral spring preferably of phosphor bronze. The cable 45 is preferably protected by means of a coil spring 46 which surrounds the cable and which passes through the end of the member 36, thereby protecting the cable from injury through contact with the end member. The end member 36 is provided with a pin 36^x (see Figs. 2 and 10) which is arranged to enter the groove 1^x in the casing 1 so as to bring the contacts 32 and 33 on the insulating plate 30 into alignment with the contacts 39 and 41 respectively carried by the insulating disk 38.

From the foregoing description of the various parts of the device the operation thereof may be readily understood. The tool is designed to be used with a three-wire circuit in which there is either a pulsating direct or an alternating current. The means by which the alternations or pulsations are produced forms no part of the present invention. Any kind of a tool 8, such as a riveting tool may be inserted in the socket in the bushing 7. The operator grasps the tool by means of the chuck case 4, which is shaped to fit the hand. By pressing on the end of the tool the operator forces the part 12 rearwardly, this part being connected with the member 11^a, and the latter being secured to the part 5. These parts are also moved rearwardly. I have provided pins 45, which are arranged to pass through openings in the plate 9. These pins have one end in engagement with the member 5 and the opposite end engages a plate 13, which forms the end of the spool. The latter together with the coils is moved rearwardly, so as to bring the contacts 32 and 39 into engagement and simultaneously the contacts 33 and 41. This completes a circuit, which is as follows: from lead wire 42^w (see Fig. 1) through 43, 41, 33, wire 35, coil 17, conductor 29, 28, 42, lead 44 to return wire 44^w. This causes the plunger 19 to be drawn inwardly toward the spring 27, which cushions the movement of the plunger at this end of the device. If the current is a pulsating one, the current will presently be cut off from the wire 42^w and the wire 40^w will become the active wire. As soon as the wire 40^w is charged the current will flow from it through the wire 40, 39, 32, conductor 34, through the solenoid 16 and by the return wire 29 to contacts 28, 43, 44 to return wire 44^w. The coils 16 and 17 are wound in opposite directions, and hence

when the coil 16 is energized the plunger will be pulled in the opposite direction and delivers its blow upon the striking pin 20, which in turn communicates it to the end of the tool 8. The plunger 19 is formed of hardened steel, and tends to have residual magnetism, but as the polarity of the coil 16 is opposite from that of the coil 17 the effect of the striking of the plunger 19 is to neutralize all the magnetism left in it by the coil 16, thereby allowing it to immediately release itself from the striking pin 20. It will be obvious that as long as the tool is pressed into contact with the work the connections will be effected at the rear end of the solenoid through the contacts 32—39 and 33—41. When, however, the tool is withdrawn from the work, then the spring 42 will push the solenoids and their contacts 32 and 33 toward the forward end of the tool, thereby breaking the circuit.

The arrangement just described, which permits the disconnection of the coils from their actuating circuits immediately when the tool is withdrawn from the work, prevents the overheating of the coils. Furthermore, the parts are kept cool by the ventilating openings such as those shown at 4^b in the plate 4, the openings 10 in the plate 9, the opening 13^b in the plate 13, the perforations 18^a in the casing 18, the perforations 21 in the outer casing 1, and the opening 31 through the nut 26 and the insulating washer 27. With these ventilating openings the parts are thoroughly cooled, and hence the device does not become unduly heated, so that the tool may be operated at a cooler temperature than hitherto possible. The grooving of the plunger 19 also forms radiating strips between the grooves, which rapidly dissipate the heat absorbed by the plunger. The grooves 11^b in the member 11 permit the passage of the air coming from the openings 13^b to the interior of the spool 14, so as to provide plenty of cool air for cooling the plunger.

The means for regulating the stroke of the plunger is as follows: On turning the casing 4, it will be observed that the member 5 will be rotated by the engagement of the pin 6 in the slot 5^a (see Fig. 2). The rotation of the member 5 will cause a relative movement between the threaded head 11^a of the member 11 and the member 5 for the reason that the member 11 is prevented from turning by the pin 9^a, which is carried by the extension 9^a of the plate 9. This pin extends into a slot 11^a. The member 11 will therefore be forced inwardly when the member 4 is turned in one direction, and outwardly when it is turned in the other direction. As the member 11 is moved inwardly toward the plunger, the striking pin follows it. This, it will be seen, will tend to decrease the stroke of the plunger, while turn-

ing the member 4 in the opposite direction will tend to increase it. Thus the stroke of the plunger 19 may be regulated by merely turning the member 4 in one direction or the other.

In Fig. 12, I have shown a modified form of the tool in which the chuck casing instead of being solid is provided with a series of grooves 4^k for permitting access of the air nearer to the working parts and providing a series of radiating flanges 4^m between the grooves 4^k, so as to form a better radiator of heat.

In Fig. 14, I have shown a modified form of handle in which the tool is provided with a pistol grip 36^e. This pistol grip 36^e forms an integral part of the end member 36 and the wires 42, 44 and 40 are carried out through the handle, as shown in Fig. 14. The cable 45 in this instance is secured in position by means of a nut 45^k. The handle 36^e is preferably made of aluminum.

As will be seen from Fig. 2, the reduced portion 22 of the striking pin 20 in its normal position is slightly away from the end of the tool 8, so that when the pin 20 is struck by the plunger 19, it delivers a much sharper blow to the tool than would be possible if the latter were in contact with the member 22. I desire also to call special attention to the fact that the perforated casing 18 forms a magnetic path for the lines of force of the solenoids 16 and 17, as well as protecting these coils. Another feature which should be emphasized is the fact that the plunger is made of hard steel which is demagnetized in the manner already explained. Heretofore the plunger has been made of soft iron capped with hard steel at its striking end.

The device described above is of light weight, is economical of current, due to the fact that when the tool is withdrawn the circuit connections are instantly broken, and does not heat up in operation, owing to the system of ventilation described. The ease with which the stroke of the hammer is adjusted also renders the device capable of more extended use than with tools in which such adjustment is not possible.

I claim:

1. In an electrically operated implement, a casing, a pair of solenoids mounted within said casing, a common plunger for said solenoids, a tool carried by said casing, means for alternately energizing said solenoids, thereby causing a reciprocatory movement of said plunger, and a striking pin disposed between the end of the tool and the plunger for communicating the motion of the plunger to the tool, one end of said striking pin being normally spaced apart from the end of the tool.

2. In an electrically operated implement, a casing, a pair of solenoids mounted within

said casing, a common plunger for said solenoids, a tool carried by said casing, means for alternately energizing said solenoids, thereby causing a reciprocatory movement of said plunger, a striking pin disposed between the end of the tool and the plunger for communicating the motion of the plunger to the tool, one end of said striking pin being normally spaced apart from the end of the tool, and means for regulating the stroke of the plunger.

3. In an electrically operated implement, a casing, a slidable spool disposed within said casing, a pair of solenoids carried by said slidable spool, a pair of contacts carried by said casing and arranged to be engaged by the first mentioned contacts, a common plunger for said solenoids, an extension carried by said casing, a tool carried by said extension, a pin disposed between said plunger and said tool for communicating the motion of the plunger to the tool, and movable means disposed between the tool and the spool for causing a movement of the spool to bring the contacts into engagement when the tool is pressed against the work.

4. In an electrically operated implement, an outer casing, a spool disposed within said outer casing, said spool being provided with a pair of contacts at its end, a pair of contacts carried by the end of the casing and arranged to be engaged by the first mentioned contacts, a pair of solenoids carried by said spool, the movement of said spool serving to bring the contacts together, thereby energizing the solenoids, and a perforated sheet iron casing disposed around the solenoids and movable with the latter, said casing forming part of a magnetic circuit for the solenoids.

5. In an electrically operated implement, an exterior casing provided with a pair of contacts at its end, a slidable spool disposed within said casing, a pair of contacts on the end of said slidable spool arranged to engage said first named contacts, a spring disposed between the end of the casing and the end of the spool, a pair of solenoids carried by said spool, a source of current connected to the contacts on said casing, a tool, and means disposed between said tool and said spool for moving the latter to bring the contacts into engagement.

6. In an electrically operated implement, an exterior casing provided with a pair of contacts at its end, a slidable spool disposed within said casing, a pair of contacts on the end of said slidable spool arranged to engage said first named contacts, a spring disposed between the end of the casing and the end of the spool, a pair of solenoids carried

by said spool, a source of current connected to the contacts on said casing, a tool, means disposed between said tool and said spool for moving the latter to bring the contacts into engagement, and a common plunger for said solenoids adapted to transmit motion to said tool.

7. In an electrically operated implement, an exterior casing provided with a pair of contacts at its end, a slidable spool disposed within said casing, a pair of contacts on the end of said slidable spool arranged to engage said first named contacts, a spring disposed between the end of the casing and the end of the spool, a pair of solenoids carried by said spool, a source of current connected to the contacts on said casing, a tool, means disposed between said tool and said spool for moving the latter to bring the contacts into engagement, a common plunger for said solenoids adapted to transmit motion to said tool, and means for adjusting the movement of said plunger.

8. In an electrically operated implement, an exterior casing provided with a pair of contacts at its end, a slidable spool disposed within said casing, a pair of contacts on the end of said slidable spool arranged to engage said first named contacts, a spring disposed between the end of the casing and the end of the spool, a pair of solenoids carried by said spool, a source of current connected to the contacts on said casing, a tool, means disposed between said tool and said spool for moving the latter to bring the contacts into engagement, and a common plunger for said solenoids adapted to transmit motion to said tool.

9. In an electrically operated instrument, an outer casing, a solenoid slidably disposed within said outer casing, a chuck rigidly secured to said outer casing, a tool slidably carried by said chuck, means disposed between said tool and said solenoid for imparting a movement of the tool to the solenoid, contacts carried by said solenoid, and contacts carried by said casing and arranged to be engaged by the first named contacts during the movement of the solenoid.

10. In an implement, a casing, a plunger mounted within the casing, a tool carried by said casing, means for causing a reciprocatory movement of the plunger, and a striking pin disposed between the end of the tool and the plunger for communicating the motion of the plunger to the tool, the end of said striking pin being normally spaced apart from the end of the tool.

LOUIS PAULERO.

Witnesses:

JOHN MCS. BUCHANAN,
RICH. D. GILLIAM.