



(51) International Patent Classification:

F25D 11/00 (2006.01) F25D 17/04 (2006.01)  
F25D 16/00 (2006.01) F25D 23/00 (2006.01)

(21) International Application Number:

PCT/IT2012/000033

(22) International Filing Date:

1 February 2012 (01.02.2012)

(25) Filing Language:

Italian

(26) Publication Language:

English

(30) Priority Data:

FI2011A000018 2 February 2011 (02.02.2011) IT

(71) Applicant (for all designated States except US): C.P.S.I. [IT/IT]; Consulenze Progettazioni & Servizi Integrati S.R.L., Via Roma, 57, I-50060 Londa (FI) (IT).

(72) Inventor; and

(75) Inventor/Applicant (for US only): BRACCINI, Maria Laura [IT/IT]; Via Roma, 57, I-50060 Londa (FI) (IT).

(74) Agent: CICCARELLO, Basilio; c/o INGENIIS S.a.s. di B. Ciccarello e C., Via Antonio De Berti, 24, I-00143 Roma (IT).

(81) Designated States (unless otherwise indicated, for every kind of national protection available): AE, AG, AL, AM, AO, AT, AU, AZ, BA, BB, BG, BH, BR, BW, BY, BZ, CA, CH, CL, CN, CO, CR, CU, CZ, DE, DK, DM, DO, DZ, EC, EE, EG, ES, FI, GB, GD, GE, GH, GM, GT, HN, HR, HU, ID, IL, IN, IS, JP, KE, KG, KM, KN, KP, KR, KZ, LA, LC, LK, LR, LS, LT, LU, LY, MA, MD, ME, MG, MK, MN, MW, MX, MY, MZ, NA, NG, NI, NO, NZ, OM, PE, PG, PH, PL, PT, QA, RO, RS, RU, RW, SC, SD, SE, SG, SK, SL, SM, ST, SV, SY, TH, TJ, TM, TN, TR, TT, TZ, UA, UG, US, UZ, VC, VN, ZA, ZM, ZW.

(84) Designated States (unless otherwise indicated, for every kind of regional protection available): ARIPO (BW, GH, GM, KE, LR, LS, MW, MZ, NA, RW, SD, SL, SZ, TZ, UG, ZM, ZW), Eurasian (AM, AZ, BY, KG, KZ, MD, RU, TJ, TM), European (AL, AT, BE, BG, CH, CY, CZ, DE, DK, EE, ES, FI, FR, GB, GR, HR, HU, IE, IS, IT, LT, LU, LV, MC, MK, MT, NL, NO, PL, PT, RO, RS, SE, SI, SK, SM, TR), OAPI (BF, BJ, CF, CG, CI, CM, GA, GN, GQ, GW, ML, MR, NE, SN, TD, TG).

[Continued on next page]

(54) Title: REFRIGERATING APPLIANCE

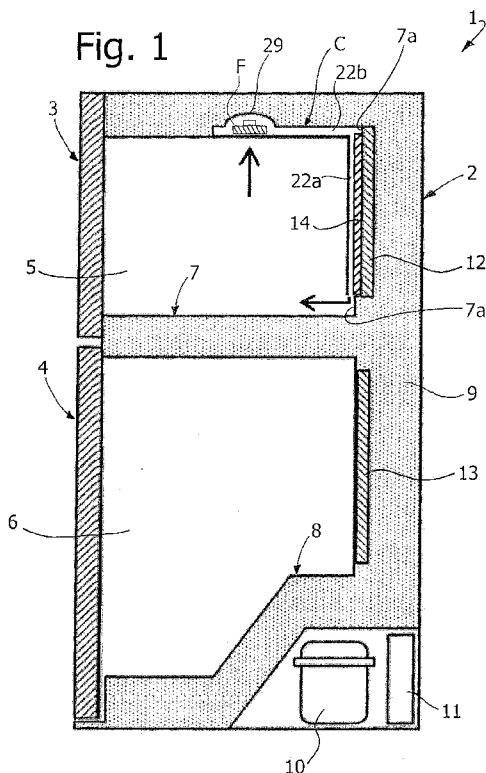

(57) Abstract: A refrigerating appliance has a cabinet (2) with a storage compartment (5) delimited by a body (7), and a refrigerant circuit. The storage compartment (5) is cooled by an evaporator (12), which is mounted parallel near a first wall (7a) of the body (7). Mounted in a fixed position in correspondence of the first wall (7a) is also a thermal accumulator (14) containing eutectic material, which extends with its larger face in thermal contact with a surface of the first wall (7a). In correspondence of the first wall (7a), the body (7) defines integrally a seat (15) having a slot (16) for the insertion of the thermal accumulator (14). The slot (16) is formed in the body (7) in correspondence of a connecting zone between the first wall (7a) and a second wall (7d) of the body (7) adjacent to the first wall (7a).

WO 2012/104884 A2

**Published:**

- *without international search report and to be republished upon receipt of that report (Rule 48.2(g))*

## REFRIGERATING APPLIANCE

### **Technical field**

The present invention relates to a refrigerating appliance, particularly but not  
5 exclusively a domestic refrigerator, of the type indicated in the preamble of claim  
1.

### **Background art**

The use of thermal energy accumulators containing an eutectic material, for  
example in the form of liquid or gel, is generally well known in the field of  
10 refrigeration.

In some known solutions, eutectic thermal accumulators are configured as  
containers freely positioned and movable within a storage compartment of a  
domestic refrigerator. In other solutions, an eutectic material container is  
integrated into trays in the storage compartment of the refrigerator. Even in this  
15 kind of solutions, therefore, the thermal accumulator is removable or possibly  
extractable from the refrigerator.

In another type of known solutions, to which the present invention refers, one or  
more thermal accumulators are permanently integrated into the structure of the  
refrigerator.

20 A solution of this type is known, e.g. from WO2009/000722, according to which  
one or more internal surfaces of the storage compartment are constituted by  
walls of thermal accumulators arranged to form at least a part of the  
compartment. Solutions of this type, even if technically feasible, are extremely  
complex and expensive from the point of view of the industrial production, as  
25 they require substantial structural changes and high investments, and are not  
generally suitable to a mass production.

For this reason, in most of the known cases in which one or more thermal  
accumulators are configured as fixed parts of a refrigerator, the accumulators  
themselves are arranged outside the storage compartment in contact with one or  
30 more external surfaces of the walls that delimit the same compartment.

A solution of this type is known from EP-A-0974794, on which the preamble of claim 1 is based. A refrigerator is described in which a thermal accumulator, being configured as a rigid or semi-rigid container of eutectic material, is associated so to lean against one of the lateral walls, in particular its upper wall, that delimit the storage compartment. The evaporator designed to cool the storage compartment is positioned above this thermal accumulator.

The arrangement according to EP-A-0974794 appears to be simpler and more economical than the one described in WO2009/000722, however it still implies a certain complexity of assembly of the refrigerator. In particular, the thermal accumulator has to be fixed in contact with the outer surface of the wall of the body or plastic shell that defines the compartment. Then an evaporator has to be placed over the thermal accumulator and fixed to the latter and/or to the wall of the body of the compartment. The group so obtained must be mounted over the cabinet which forms the refrigerator, and a thermal insulator, commonly a foamed or expanded material, has to be injected into the cavity between the cabinet itself and the body of the compartment.

### **Disclosure of invention**

The present invention aims to overcome the above mentioned drawbacks of the background art, and in particular to provide a refrigerating appliance of the type including at least one simple and cheap to be built accumulator of thermal energy.

A further object of the present invention is to indicate a particularly advantageous method for making a refrigerating appliance, method that allows a simplification of the mounting operations and requires a moderate investment.

An additional object of the present invention is to provide a refrigerating apparatus with improved functions in connection with the maintenance of optimal conditions of temperature and moisture inside a storage compartment, particularly for fresh foods.

These and other objects, that will become more apparent hereinafter, are achieved according to the present invention by a refrigerating appliance whose

features are stated in claim 1 and by a method for making a refrigerating appliance whose features are stated in claim 13. The claims constitute an integral part of the technical teaching provided in relation to the invention herein.

### **Brief description of drawings**

- 5 Further objects, features and advantages of the invention will become apparent from the detailed description which follows, with reference to the accompanying drawings being provided as a non-limiting example, where:
- Figure 1 is a diagrammatic cross-section of a refrigerating appliance according to the present invention;
  - 10 - Figures 2 and 3 are diagrammatic perspective views of a body made of plastic material defining a plurality of walls of a storage compartment of the refrigerating appliance in Figure 1, with an associated air conveyor belonging to a forced air circulation system within the said compartment;
  - Figure 4 is a diagrammatic perspective fragmentary view of a portion of the  
15 body in Figures 2 and 3;
  - Figure 5 is a diagrammatic plan view of the body in Figures 2 to 4, without said air conveyor and with a thermal accumulator mounted over it;
  - Figures 6 and 7 are a diagrammatic perspective view and an exploded view respectively of a thermal accumulator of the refrigerating appliance in Figure 1;
  - 20 - Figure 8 is a diagrammatic perspective view of an intermediate component of the thermal accumulator in Figures 6 and 7;
  - Figure 9 is a diagrammatic fragmentary cross-section of the thermal accumulator in Figures 6 and 7;
  - Figure 10 is a view of the body made of plastic material which defines the walls  
25 of the storage compartment, without said air conveyor and with the thermal accumulator in an installed condition; and
  - Figure 11 is a diagrammatic cross-section of a connecting zone between the rear and the ceilings of the plastic body in Figures 2 and 3, with the air conveyor and the thermal accumulator assembled in normal operating conditions of the  
30 refrigerating appliance.

### Description of preferred embodiments of the invention

The reference to "an embodiment" within this description means that a particular configuration, structure, or characteristic described in connection with the embodiment is included in at least one embodiment. Thus, the terms like "in one  
5 embodiment" and similar in various parts of this description, do not necessarily all refer to the same embodiment. Furthermore, the particular configurations, structures or characteristics may be combined in any suitable manner in one or more embodiments. The references are used in the following only for comprehension's sake and do not define the spirit and the aim of the  
10 embodiments.

With particular reference to Figure 1, a general refrigerating appliance for domestic use according to the teachings of the present invention is diagrammatically shown in cross-section. The refrigerating appliance, generally indicated as 1, has a cabinet 2, whose construction is *per se* known, defining  
15 external walls in view.

Frontally the cabinet 2 has two doors indicated as 3 and 4, which also are conventional. Defined inside the cabinet 2 are two storage spaces or compartments, which are indicated in Figure 1 as 5 and 6, and often simply called compartments below. Assuming that the compartment 5 is designed to storage  
20 fresh products such as fruits, vegetables, cheeses.

It is understood that the refrigerating appliance 1 is represented with two compartments only by a way of example: in the embodiment of the invention, the refrigerating appliance may have both a single compartment and two or more compartments, alternatively it may be a chest refrigerating appliance; further the  
25 invention can also be embodied in industrial refrigerators.

Only by a way of example, compartments 5 and 6 are defined by respective compartment bodies or shells made of plastic material, where each body integrally defines a plurality of side walls and a rear wall. In the example there are two bodies, indicated as 7 and 8, but in practice the walls limiting the two  
30 compartments 5 and 6 may be defined by a single body made of plastic material,

as known in the state of art.

Only according to the state of art, a thermally insulating means is interposed between the cabinet 2 and each body 7 and 8. In the exemplified embodiment, the insulating means is a polyurethane foam, indicated as 9. In alternative  
5 embodiments, the insulating material may be of an other kind, and optionally it can include a gap in which vacuum is created.

The refrigerating appliance 1 further comprises a refrigerant circuit of a *per se* known kind, which is not described in detail. It is enough to set forth that such a refrigerant circuit preferably comprises at least one compressor 10, at least one  
10 condenser 11 and at least one evaporator associated with each storage compartment. Therefore, in the exemplified embodiment two evaporators are provided, which are indicated as 12 and 13. The refrigerating appliance also comprises a control system, not shown since also it is made as known. The control system includes thermostatic means for setting the desired temperature  
15 within each compartment 5 and 6 and controlling its maintenance.

In the non-limiting shown example, evaporators 12 and 13 are arranged in close proximity of the rear wall 7a, 8a of the bodies 7 and 8, i.e. the wall that is generally opposite to the relative door 3 and 4, particularly in thermal contact with the external surface of said rear wall. However, in alternative embodiments  
20 not shown, evaporators 12 and 13 - which may be of any known type, for example plate-shaped or comprised of a simple pipe coil - can be associated also to side walls of the bodies 7 and 8.

According to the state of art, the space inside of each compartment 5 and 6 is cooled by the respective evaporator 12 and 13 that extends in a position generally  
25 parallel to its rear wall, in thermal contact with the latter.

A thermal accumulator containing eutectic material is associated in a fixed position with the rear wall of at least one of the two compartments 5 and 6, in the shown example the rear wall of the compartment 5. Preferably, the thermal accumulator, generally indicated as 14 in figure 1, is substantially configured as a  
30 rigid or semi-rigid panel.

The thermal accumulator 14 is mounted on the body 7 so as it extends substantially parallel to the rear wall of the body 7 and to the evaporator 12, a larger face of the thermal accumulator 14 being in thermal contact with a surface of said rear wall, as it will be explained later.

5 A particularly advantageous embodiment of body 7 is shown in various views in Figures 2 - 4, which are diagrammatic perspective views of body 7 defining a plurality of walls of a storage compartment of the refrigerating appliance in Figure 1, with an associated air conveyor belonging to a forced air circulation system within said compartment, as described later. Such a body 7 is advantageously  
10 formed in a single piece, e.g. made of polystyrene by thermoforming or injection. As it is depicted in Figures 2 and 3, body 7 defines a front flange 7b as well as a plurality of side walls and said rear wall 7a. The side walls include in particular two flanks 7c, a ceiling 7d and a bottom 7e.

According to a feature of the invention, the body 7 integrally defines a seat 15 for  
15 the thermal accumulator 14, in correspondence with the rear wall 7a of the body 7. In the illustrated embodiment the seat 15 has a rear wall substantially coinciding with the rear wall 7a of the body 7 of the compartment 5.

According to a further feature of the invention, the body 7 has a slot, indicated as  
16 in Figure 4, for the introduction of the thermal accumulator 14 in its seat 15.  
20 The slot 16 is formed substantially in correspondence of a connecting zone or a corner zone, or a transition area, between the rear wall 7a and a second body wall that is adjacent to the wall 7a. Therefore, in the example shown the slot 16 is formed substantially in correspondence of the connecting zone between the wall 7a and the body ceiling 7d, which is almost approximately orthogonal to the  
25 wall 7a.

In a preferred embodiment, the seat 15 is arranged to receive the thermal accumulator 14 in a guided way through the slot 16, and then from the outside of the body 7, in assembling the refrigerating appliance 1.

As shown in Figures 2 to 4, according to an embodiment of the invention, an  
30 axially extended portion of the rear wall 7a, which is substantially vertical, is

narrow in width, in order to define two opposite side walls 15a of the seat 15.

Preferably, but not necessarily, in correspondence of the side walls 15a, the body 7 integrally defines parallel opposite guides that position the thermal accumulator 14. These guides, which can be of any shape which is adapted to co-operate with  
5 corresponding side rails defined on opposite side walls of the thermal accumulator 14, are represented only diagrammatically and are indicated as 17 in Figure 5, in which the thermal accumulator 14 is shown in a plan view without air conveyor. In this way, the thermal accumulator 14 can be inserted into the seat 15, preferably in a guided way thanks to the guides 17, through the slot 16, from the  
10 top, and then from the outside of the body 7.

Preferably, the body 7 is also shaped so as to define a bottom of the seat 15, or at least one or more abutments, in a position generally opposite to the slot 16, on which the thermal accumulator 14 rests when is inserted in an operating position within the seat 15.

15 It should be understood that, in the exemplified embodiment and in the assembled configuration, one of the larger faces of the thermal accumulator 14 – here, its rear face - is in thermal contact with an internal surface of the rear wall 7a, the thermal accumulator 14 extending generally mainly within the space delimited by the walls of the body 7, i.e. within the compartment 5. Therefore, in  
20 the exemplified embodiment the rear wall 7a of the compartment body 7 is interposed between the evaporator 12 and the thermal accumulator 14.

Turning again to the not limiting embodiment illustrated, the seat 15 is generally frontally opened, in such a way that the front larger face of the thermal accumulator 14 generally faces the inner space delimited by the compartment  
25 body 7.

As mentioned, in an embodiment as represented in the figures, the thermal accumulator 14 is substantially configured as a rigid or semi-rigid panel, that is constructed so as to define internally a plurality of vessels for containing the eutectic material. The eutectic material used for the implementation of the  
30 invention can be the most suitable of a type *per se* known.

For example, the panelled structure of the thermal accumulator 14 comprises a first and a second plate, i.e. a front plate and a rear plate being indicated as 14a and 14b in Figures 6 and 7, which are a diagrammatic perspective view and an exploded view respectively of the thermal accumulator 14. Between the two plates 14a and 14b at least an intermediate body 14c is interposed and retained that is preferably made of moulded thermoplastic material and is constructed to define at least a part of said vessels for containing eutectic material. In Figure 8 there is shown in perspective view a larger face of said intermediate body 14c while Figure 9 shows a diagrammatic cross-section thereof, together with the front plates 14a and 14b.

As shown, particularly in Figure 9, the intermediate body 14c has a cross-sectional shape so that it defines a plurality of vessels 18, which communicate with each other or not, in order to contain the eutectic material, for example a gel or a liquid. The thermoplastic material used for making the intermediate body 14c has an even small elasticity, and at least some of the vessels 18 are kept empty or partly empty, in order to allow an increase in volume of the eutectic material after its solidification. Also the material used for the formation of the plates 14a and 14b can conveniently be a plastic material, and consequently also at least slightly elastically deformable to allow changes in volume of the eutectic material. The intermediate body 14c is sealed between the two plates 14a and 14b, for example by vibration or hot blade welding. The eutectic material can for example be inserted in the vessels 18 from an end of the intermediate body 14c, said end being provided with one or more openings that are afterwards sealed. Alternatively, the eutectic material can be prearranged in blocks or packs that are positioned in the intermediate body 14c before the welding of the plates 14a and/or 14b.

In a particularly advantageous embodiment of the invention, the intermediate body 14c is constructed so that an internal housing substantially semi-cylindrical and coil shaped is defined, which is indicated as 19 in Figure 8 and partially visible also in Figure 9.

In this embodiment, a metal pipe, for example a copper one, which constitutes the same evaporator intended for cooling the storage compartment 5, can be positioned within this housing 19. When said pipe coil, not shown, is in the assembled and operational condition, it is at least slightly pressed and anyway in thermal contact with the inner surface of the front plate 14b of the thermal accumulator 14.

In the embodiment exemplified in Figure 1, the evaporator 12 is positioned outside of the compartment 5, behind the wall 7a, and in contact with the latter. In the alternative embodiment just above-mentioned, the pipe coil which constitutes the evaporator is integrated into the thermal accumulator 14: according to such an embodiment, the two ends of the pipe coil can protrude through respective passageways defined in the rear plate 14b or in the intermediate body 14c, not shown in the figures, in order to connect the compressor 10 to the condenser 11 in the refrigerant circuit, an expansion valve being possibly interposed between them, all in accordance with the well known art in this field. For this purpose, appropriate passageways will be defined in a suitable position also in the wall 7a.

According to a particularly advantageous feature of the invention, the compartment 5 is provided with a forced air circulation system including a duct for the air. This forced air circulation system is part of an arrangement designed to maintain generally constant conditions of temperature and moisture within the compartment 5.

As mentioned above, the seat 15 for the thermal accumulator 14 is frontally open. In this way, the front plate 14a, that is a larger face of the thermal accumulator 14, is directly exposed inside the space delimited by the walls of the compartment body 7. According to an embodiment, a wall 20 is added to the body 7 in front of the thermal accumulator 14, in order to obtain said air circulation and humidifying system.

The wall 20, as shown in Figure 2, is a part of an air conveyor, generally indicated as C. In the assembled condition, the wall 20 substantially frontally closes the

seat 15 of the thermal accumulator 14, whose bottom is open towards the inside of the compartment 5, to allow the passage of air. This is clearly shown for example in Figure 11, which is a diagrammatic cross-section of a connecting zone between the rear wall 7a and the top wall 7d of the body 7 of figures 2 and 3, when the air conveyor and the thermal accumulator are assembled in normal operating conditions of the refrigerating appliance.

The wall 20 extends generally parallel to the front plate 14a of the thermal accumulator 14, at a certain distance from the front plate 14a: in this way, a cavity that is a part of a duct of said air circulation system is defined between the plate 14a and the wall 20 and indicated as 22a.

In the illustrated example of Figure 11, the air conveyor C has a body, which is e.g. formed of moulded plastic material, having two generally parallel walls, a lower wall 25 and an upper wall 26. The lower wall 25 and the upper wall 26 define a first portion 22b of said duct for the air between them, together with their respective side walls 27 (Figures 2 and 3). The lower wall 25 leans on the outside of the ceiling 7d of the body 7, and the wall 20 extends perpendicularly from a distal end of the wall 25 of the air conveyor C and downward through the slot 16 inside the compartment 5. Advantageously, the seat 15 can be shaped so that to define also guide means for the sliding insertion of the wall 20. The body of the air conveyor C has also a rear wall 28 intended to be coupled, for example glued or welded, to the rear wall 7a of the compartment body 7.

As shown particularly in Figures 2 and 3, the body of the air conveyor C also defines a generally circular chamber indicated as 29 at the proximal end of both the walls 25 and 26. In the assembled condition of the air conveyor C, the generally circular chamber is in fluid communication with an opening 30 formed in the ceiling 7d of the body 7 (Figures 4 and 5).

Mounted within the chamber 29 or inside the body 7 in correspondence of the opening 30 is a fan *per se* known, for example a centrifugal fan with central suction, only schematically shown in Figure 1, in which it is indicated as F.

Furthermore, with reference to the non-limiting example of Figure 11, the front

plate 14a of the thermal accumulator 14 is shown extending in height so as to protrude beyond the slot 16, up to the inside of the body of the air conveyor C, in contact with its upper wall 26. In this way, defined between the upper wall 26, the generally vertical wall 20 and the front plate 14a of the thermal accumulator 14 is the cavity 22a which, as mentioned, is a section of the air circulation duct.

Figure 11 also shows that the rear plate 14b of the thermal accumulator 14 is in direct contact with the inner surface of the rear wall 7a of the body 7. In the example, the thermal accumulator 14 is just about an entire wall of the room that contains the food and creates a sort of "thermal filter" that allows the maintenance of the correct temperature within the compartment 5.

Shortly, in the operational conditions of the refrigerating appliance 1, the units of refrigeration generated by the evaporator 12 are accumulated by the eutectic material and distributed inside the compartment 5. According to the *per se* known principle of operation of the containers of eutectic material, the thermal accumulator 14 allows the temperature inside the compartment 5 to be maintained substantially constant, without any significant variation, even in periods in which the operation of the refrigerant circuit is interrupted, in particular during the stops of the compressor 10. The presence of the thermal accumulator 14 allows also temperature to avoid any fluctuations due to the hysteresis of the thermostat, be it electronic or electromechanical, which controls the maintenance of the temperature inside the compartment 5.

In the operating conditions of the air circulation system, the fan F sucks air from the inside of the compartment 5, which can be for example a storage compartment of fresh foods such as fruit, vegetables, cheese, and forces the air into the duct that is formed, in part, by the air conveyor C. The air then enters the chamber 29 and flows along the portion 22b of the duct that is defined between the walls 25 and 26 (Figure 11). Then the air descends in the portion of the duct formed from the cavity 22a, between the wall 20 of the air conveyor C and the front plate 14a of the thermal accumulator 14.

According to a particularly advantageous feature of the invention, the thermal

accumulator 14 is arranged to maintain a value of temperature of the wall formed by the front plate 14a in the operating conditions of the forced air circulation system so that the formation or the maintenance of frost or ice on said wall is caused. In this way, the forced air passing through the duct flows over frost or ice, and absorbs moisture before entering again the storage space, as diagrammatically shown by arrows in Figure 1.

It should be noted that, differently from the known refrigerators of the "no-frost" type, in which the forced air circulation is employed in order to prevent the formation of condensation, frost or ice on the walls of a storage compartment, in the present invention the formation and/or the maintenance of frost or ice is a desired condition, for humidifying the air.

In this way, besides ensuring the maintenance of a substantially predetermined and well distributed temperature within the compartment 5, the moisture is also kept at a suitable level (the known forced air circulation systems accelerate the dehydration of fresh food in storage) for the preservation of fresh food, despite the presence of a forced air circulation system.

For this purpose, an eutectic material of the thermal accumulator 14 shall be chosen having a temperature of solidification so that the temperature of the plate 14a falls just below the value adapted to cause the formation of frost or ice on the plate 14a itself, at least in the operating conditions of the air circulation system.

This condition is diagrammatically represented in Figures 10 and 11; it should be noted that in Figure 10, which is a view of the compartment body where the representation of the air conveyor C is omitted, the front plate 14a of the thermal accumulator 14 is directly in view. In Figures 10 and 11, the reference G indicates schematically a layer of ice, formed on the wall of the duct for the air which is formed by the front plate 14a of the thermal accumulator 14. In this way, the air that is forced into the duct 22a-22b of the circulation system flows over said layer of ice G and can take moisture that can be transferred later to fresh products in the storage compartment 5.

In the forced air circulation system provided according to the above preferred embodiment of the invention, the ventilation is a low intensity one. In particular, the motor of the fan F works at a very low speed, about at least ten times lower than the speed normally used in forced air circulation systems inside of refrigerators according to the state of art, particularly those of "no-frost" type.

The refrigerating appliance according to the present invention is provided with a defrost circuit, not shown, as it is *per se* known. For example, in one embodiment, this circuit includes an electrical resistance which is switch on periodically to cause the melt of the frost or ice G. A drain hole can be made on the bottom of the compartment 5 through the lower wall 7e. The drain hole is connected to a small discharge pipe conveying defrosting water to a tray positioned above the compressor 10.

The manufacture of the refrigerating appliance according to the invention is very simple. As said, the compartment body 7 can be formed in one piece for example of polystyrene or other suitable thermoplastic material by injection or thermoforming operations.

The thermal accumulator 14 can be also made of plastic material, as mentioned by providing the two plates 14a and 14b between which the intermediate body 14c is interposed and retained that defines the vessels 18, for containing the eutectic material, and possibly the housing 19 for the evaporator coil. The eutectic material will be chosen, among the known ones, depending on the operating requirements explained above.

In the normal assembly of the refrigerating appliance, the compartment body 7 is mounted in the cabinet 2 and the thermally insulating material 9 is injected between the body 7 and the cabinet 2; alternatively a vacuum is created according to the known art.

Of course, before the execution of the phase of thermal insulation, particularly before the assembly of the body 7 in the cabinet, the thermal accumulator 14 will be mounted on the body 7. In the case in which the evaporator is in the position of Figure 1, the evaporator 12 is also associated with the rear wall 7a of the

compartment body 7, and then suitably connected to the refrigerant circuit in *per se* known ways.

The body 7, as mentioned, is shaped in a single body so as to define integrally, in correspondence of the rear wall 7a, the seat 15 for housing the thermal accumulator 14. The body 7 is also moulded so that it has the slot 16 through  
5 which the thermal accumulator 14 is slidably inserted inside the seat 15 from the outside of the body 7. The positioning accuracy can be enhanced by the guides 17, when provided; in this case, preferably, the insertion of the thermal accumulator 14 between the guides 17 takes place with slight interference  
10 between the parties.

In this way, the assembly of the thermal accumulator 14 with respect to the body 7 is extremely simple to be carried out, with a result of a substantially monolithic group of assembly. Similarly, the constructive solution is economic, since the seat 15, the slot 16 and the eventual sliding guides 17 can be obtained by simply  
15 shaping the moulds necessary for the formation of the body 7.

In the embodiments in which the forced air conveying system is provided, also the air conveyor C described above will be mounted on the body 7. Thereafter, the body 7 can be mounted on the cabinet 2. Then the thermally insulating material 9 can be injected.

20 Advantageously, after the injection of the insulating material 9 and its solidification, the material itself will exercise a certain pressure on the evaporator 12 and on the rear wall 7a of the body 7; in this way the evaporator 12 will be pressed against said rear wall 7a, and the latter will in turn be pressed against the rear plate 14b of the thermal accumulator 14, so that an optimal contact between  
25 the thermal exchange surfaces is ensured.

Of course, in the case in which the evaporator is integrated within the thermal accumulator 14, after the thermal accumulator itself is manufactured with the internal pipe coil constituting the evaporator, the thermal accumulator 14 is inserted in the respective seat 15. Two ends of said pipe coil will be connected in  
30 the refrigerant circuit, downstream of the condenser 11 and upstream of the

compressor 10, in a *per se* known manner, through two passages formed in the rear wall 7a of the compartment body 7.

It should be appreciated that the assembly operations of the refrigerating appliance are very simplified and cheap, thereby enabling to achieve the intended  
5 objects of the invention.

It is clear that numerous variants to the refrigerating appliance described as an example are possible for the person skilled in the art without thereby departing from the invention as defined by the claims that follow.

It will be appreciated for example that the specific conformation of the air  
10 circulation and/or humidifying system previously described must be considered optional.

Therefore, according to a possible embodiment, the air conveyor C is replaced by a simple substantially T-shaped body that is fixed to the ceiling 7d of the compartment body 7, in order to form the wall 20 and to close the slot 16 on its  
15 top. In this case, the front plate 14a of the thermal accumulator 14 does not protrude in height beyond the slot 16.

According to a further embodiment without the wall 20, a forced circulation system can be created, in which air can pass through the thermal accumulator 14, instead of flowing over the plate 14a. To achieve this, it is sufficient that some of  
20 the vessels 18 of the thermal accumulator 14 are kept empty of the eutectic material, so that they can work as through holes being open at their ends. In this way the vessels 18, communicating through their upper and lower ends with the rest of the forced air circulation system, act as ducts for the air. In this embodiment, the duct 22b ends at the top of the thermal accumulator 14, the  
25 corresponding wall 20 and thus the duct 22a missing. Of course, the through vessels 18 flow inside the compartment 5 through the lower end of the thermal accumulator 14.

Also in this embodiment the thickness of the thermal accumulator 14 can be equal to the sum of the thickness values provided in the embodiment shown in  
30 figure 1 for the duct 22a and to the thermal accumulator 14, while the total

volume, now provided separately, remains equal to the passage of air and the eutectic material. In this way, the air ducts are not an impediment to stow the same amount of eutectic with an advantage, however, of a greater surface of air-eutectic thermal exchange.

- 5 In another embodiment, simpler than the preceding one, the front plate 14a of the thermal accumulator 14 can be maintained in view within the compartment 5; even in this case a means for closing the slot 16 will be preferably provided.

In another possible embodiment, the body 7 can be formed in such a way as to have a double rear wall, i.e. comprising two parallel walls that define a seat for  
10 the thermal accumulator 14 between themselves, the seat being open at the top through the slot 16. Thus, in this case said seat will be closed frontally towards the inside of the compartment 5 by a wall of the same compartment body. Even in such an embodiment, a means of closing the slot 16 will preferably be provided.

- 15 In the previously exemplified embodiment, the thermal accumulator 14 is coupled with the rear wall of the compartment 5, but it should be appreciated that said thermal accumulator may be associated with one or more walls different from the rear wall in alternative embodiments.

## CLAIMS

**1.** A refrigerating appliance having:

- a cabinet (2) having at least a door (3);

- at least one storage compartment (5) inside the cabinet (2), the storage  
5 compartment (5) being delimited by a compartment body (7) that defines  
integrally a plurality of side walls (7c, 7c, 7d, 7e) and a rear wall (7a) opposite to  
the door (3), where a thermally insulating means (9) is interposed between the  
cabinet (2) and the compartment body (7);

- a refrigerating circuit including at least a compressor (10), at least a  
10 condenser (11) and at least an evaporator (12);

wherein the storage compartment (5) is cooled through the evaporator (12)  
which is mounted near a first wall (7a) among said side walls and rear wall (7c,  
7c, 7d, 7e, 7a), and substantially parallel to said first wall (7a), furthermore a  
thermal accumulator (14) containing eutectic material being mounted in a fixed  
15 position in correspondence with the first wall (7a), the thermal accumulator (14)  
extending substantially parallel to the first wall (7a) and to the evaporator (12),  
with a first larger face of the thermal accumulator (14) in thermal contact with a  
surface of the first wall (7a),

characterised in that the compartment body (7) defines integrally a seat (15) for  
20 the thermal accumulator (14) in correspondence of the first wall (7a), the  
compartment body (7) having a slot (16) for the insertion of the thermal  
accumulator (14) in the seat (15), the slot (16) being formed in the compartment  
body (7) substantially in correspondence of a connecting zone between the first  
wall (7a) and a second wall (7d) of the compartment body (7) that is adjacent to  
25 the first wall (7a).

2. The refrigerating appliance according to claim 1, wherein the seat (15) is  
arranged to receive the thermal accumulator (14) through said slot (16) in a  
guided way from the outside of the compartment body (7).

3. The refrigerating appliance according to claim 1, wherein the surface of the  
30 first wall (7a), with which the first larger face of the thermal accumulator (14) is

in contact, is a surface facing the inside of the storage compartment (5), the thermal accumulator (14) extending within the storage compartment (5).

4. The refrigerating appliance according to claim 2, wherein the first wall (7a) is a substantially vertical wall and defines at least an abutment of the seat (15),  
5 opposite to the slot (16), to which the thermal accumulator (14) rests, the second wall (7d) being a substantially horizontal wall.

5. The refrigerating appliance according to claim 2, wherein the compartment body (7) has positioning guides (17) between which the thermal accumulator (14) is constrained.

10 6. The refrigerating appliance according to claim 1, wherein the thermal accumulator (14) has a rigid or semi-rigid panelled structure that defines internally a plurality of vessels (18) for containing the eutectic material.

7. The refrigerating appliance according to claim 6, wherein the evaporator (12) is disposed outside of the storage compartment (5), the first wall (7a) being  
15 interposed between the evaporator (12) and the thermal accumulator (14).

8. The refrigerating appliance according to claim 6, wherein the evaporator includes a pipe coil which extends at least in part within the thermal accumulator (14).

9. The refrigerating appliance according to claim 6, wherein the panelled structure  
20 comprises a second larger face of the thermal accumulator (14), a portion of the second larger face (14a) projecting outside of the seat (15) through said slot (16).

10. The refrigerating appliance according to claim 9, wherein a wall (20) mounted on the compartment body (7) is added in front of the seat (15), the wall (20)  
25 extending substantially parallel to the second major face of the thermal accumulator (14), a cavity (22a) belonging to a system (C) for the forced circulation of air inside the storage compartment (5) being between the second larger face and the wall (20).

11. The refrigerating appliance according to claim 9, wherein the panelled  
30 structure comprises a first and a second parallel plate (14b, 14a) defining said

larger faces of the thermal accumulator (14), at least one intermediate body (14c), which is structured to define at least part of said vessels (18) for containing the eutectic material being interposed and retained between said larger faces, said plates (14b, 14a) and the intermediate body (14c) being of plastic material.

5 12. A method for the production of a refrigerating appliance having at least a storage compartment (5) and a refrigerant circuit including at least a compressor (10), at least a condenser (11) and at least an evaporator (12), the method comprising the steps of:

- a) providing a compartment body (7) that defines integrally a plurality of side walls (7c, 7c, 7d, 7e) and a rear wall (7a);
- b) providing a thermal accumulator (14) containing eutectic material;
- c) mounting the compartment body (7) on a cabinet (2) for refrigerating appliance in order to define a storage compartment (5);
- d) providing a thermally insulating means (9) between the cabinet (2) and the

15 wherein, before step d), near a first wall (7a) of the compartment body (7), the evaporator (12) and the thermal accumulator (14) are mounted substantially parallel to said first wall (7a), a first larger face of the accumulator thermal (14) being in thermal contact with a first surface of the first wall (7a),

20 characterised in that

- the step a) comprises the operation of forming the compartment body (7) in a single body that defines integrally a seat (15) for the thermal accumulator (14) in correspondence of the first wall (7a), and comprises a slot (16) for the introduction of the thermal accumulator (14) in the seat (15) substantially in

25 correspondence of a connecting zone between the first wall (7a) and a second wall (7d) of the compartment body (7) that is adjacent to the first wall (7a); and

- before a step chosen between the step c) and the step d), the thermal accumulator (14) is slidably inserted within the seat (15) through said slot (16), from the outside of the compartment body (7).

30 13. The method according to claim 12, wherein before a step chosen between the

step c) and the step d) the evaporator (12) is mounted on the outside of the storage compartment (5), in thermal contact with a surface of the first wall (7a) of the compartment body (7) which is opposite to said first surface of the first wall (7a).

5 14. The method according to claim 12, wherein the step b) comprises the operation of integrating at least a part of the evaporator within the thermal accumulator (14) and wherein, before one step chosen between the step c) and step d), the evaporator is connected to the refrigerant circuit downstream of the condenser (11) and upstream of the compressor (10).

10 15. The method according to claim 12, wherein the step b) comprises the operations of

- providing a front plate (14a) and a rear plate (14b);

- moulding an intermediate body of plastic material (14c) so that a plurality of vessels (18) for containing the eutectic material is partially defined; and

15 - inserting and sealing the intermediate body (14c) between the front plate (14a) and rear plates (14b).



Fig. 2

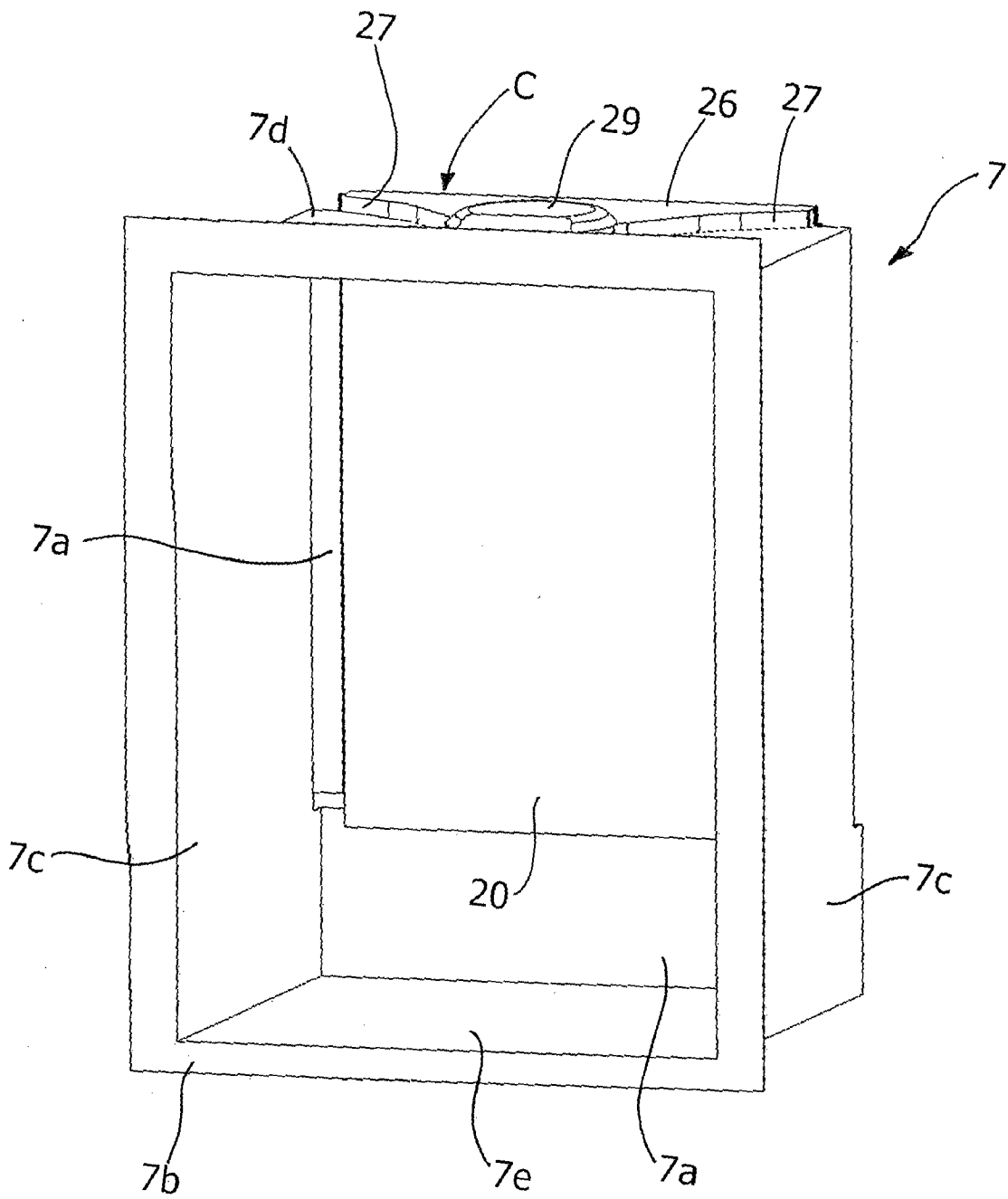
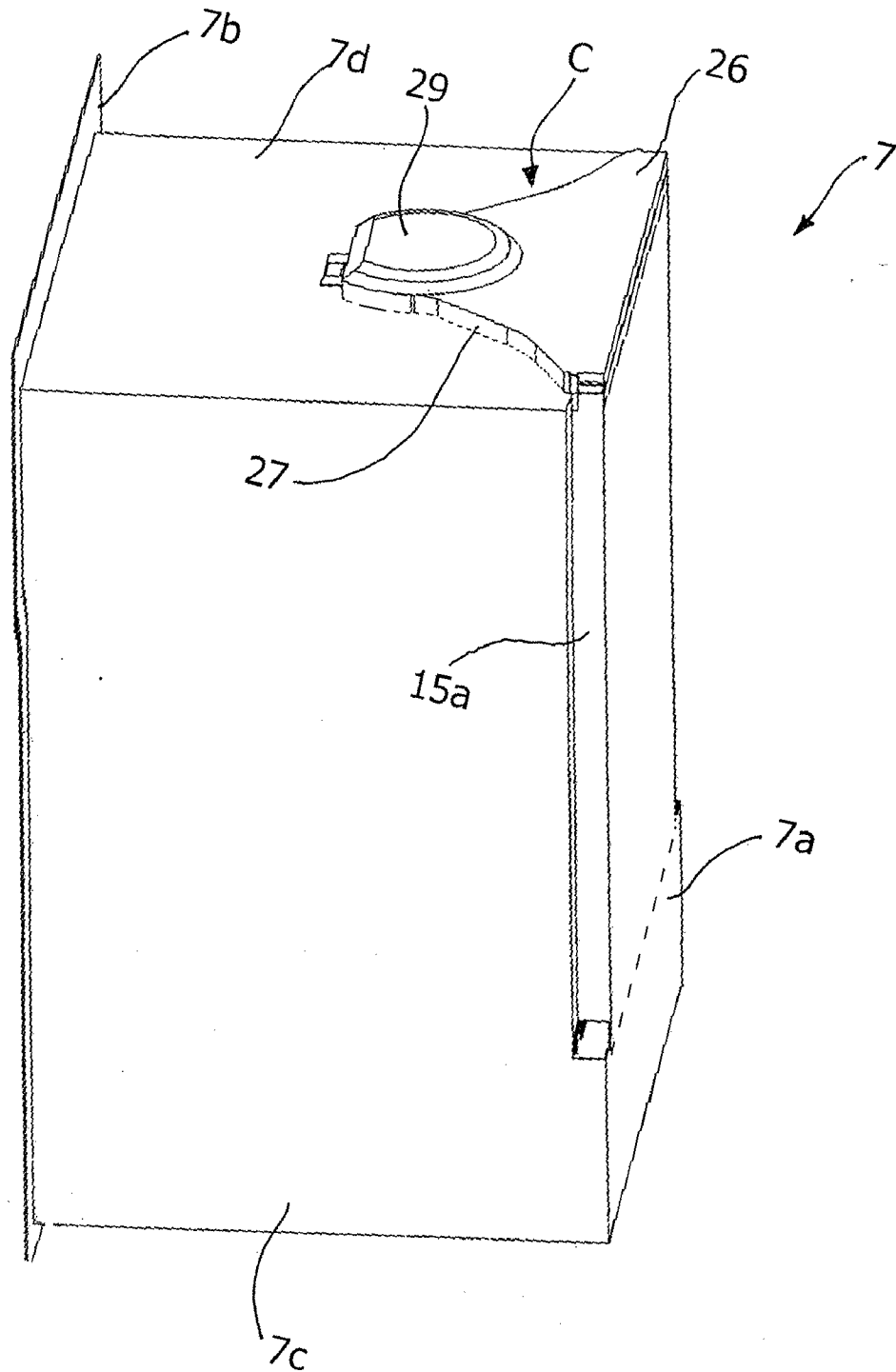

Fig. 3



4/8

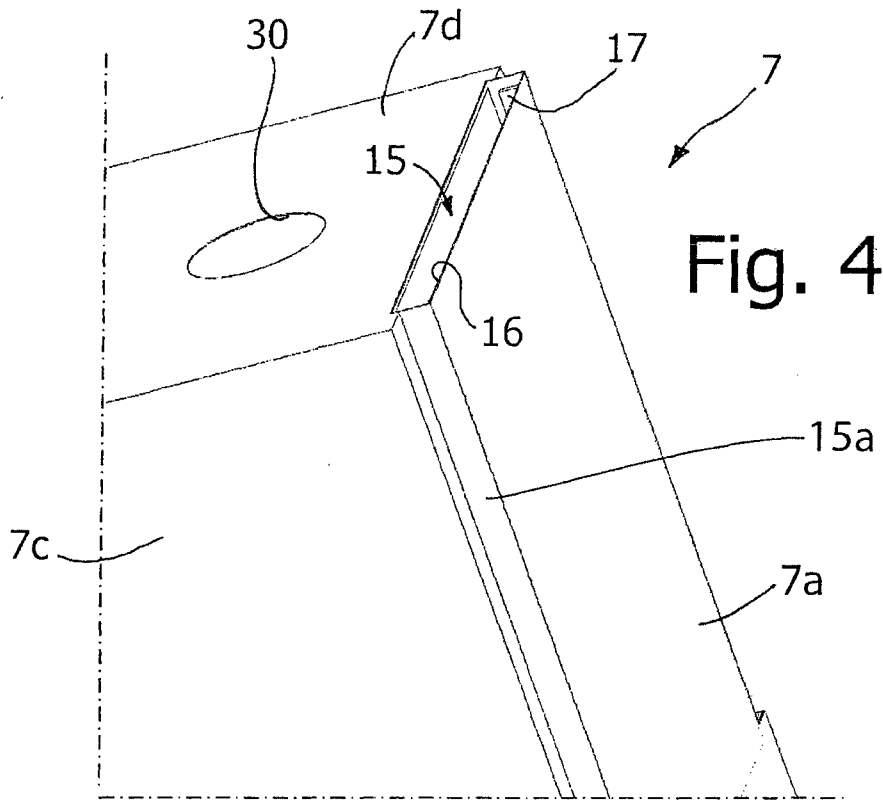

Fig. 4

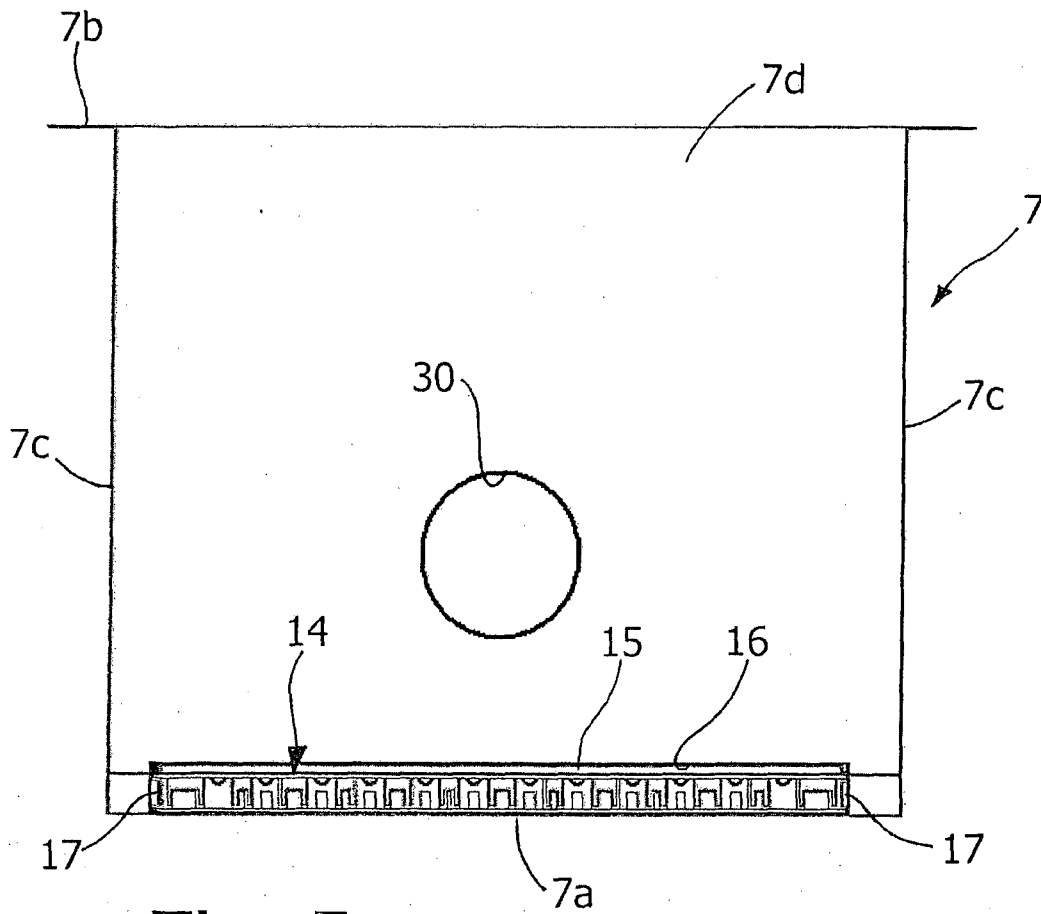

Fig. 5

5/8

Fig. 6

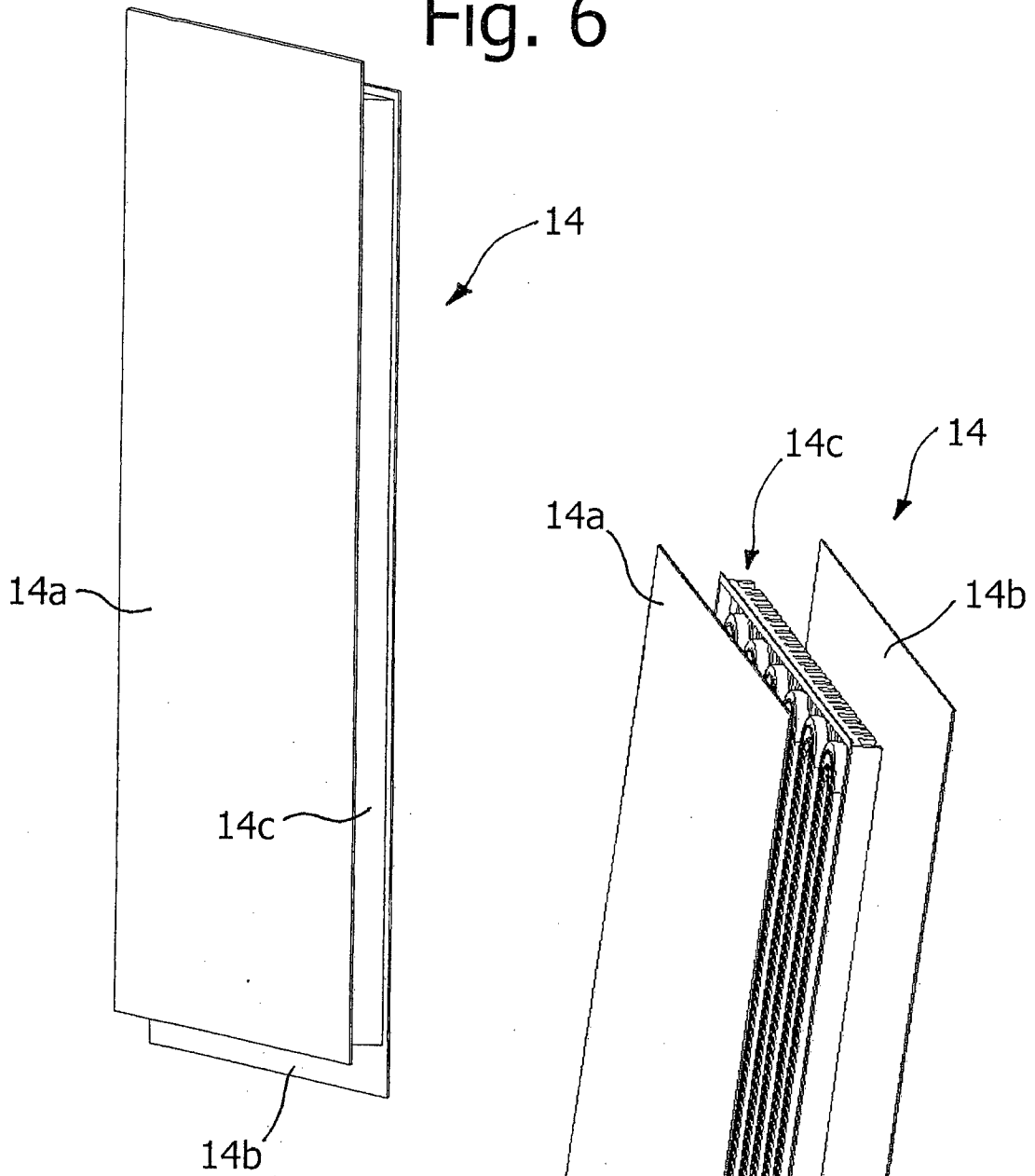
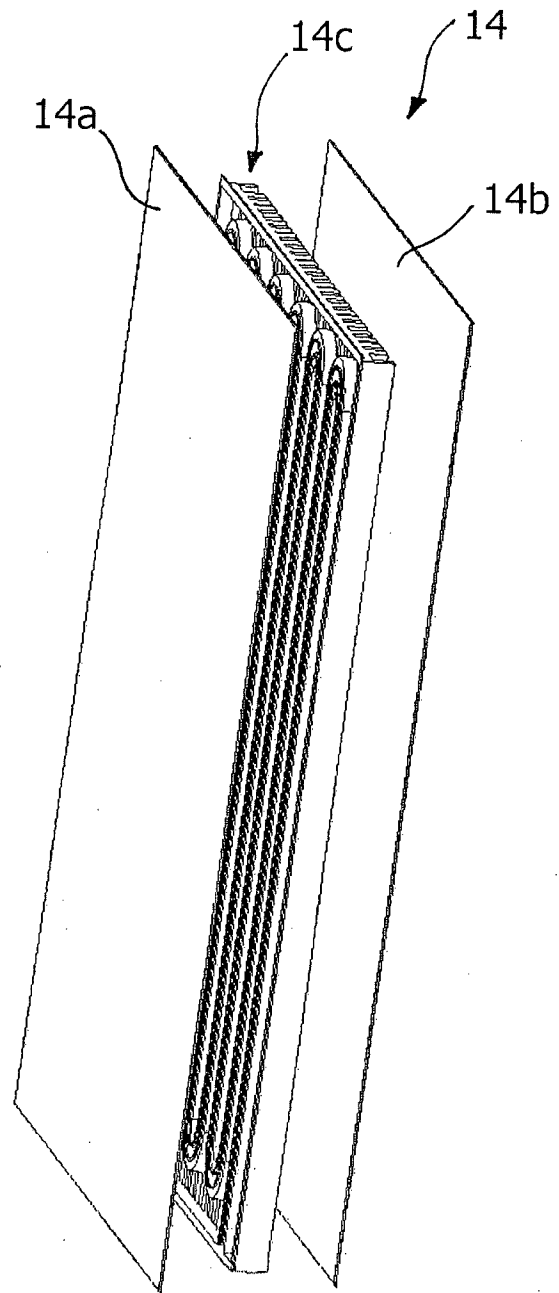

Fig. 7



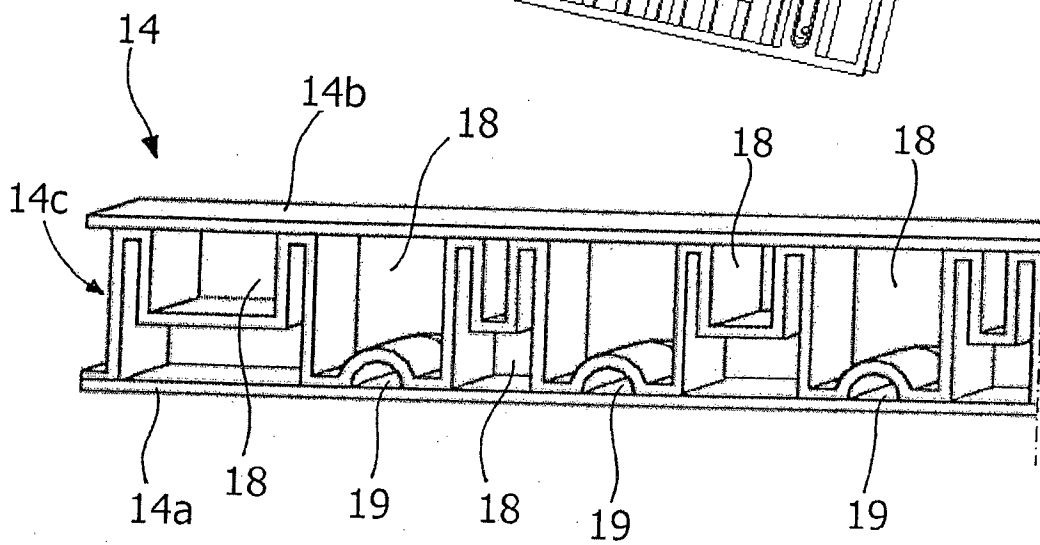
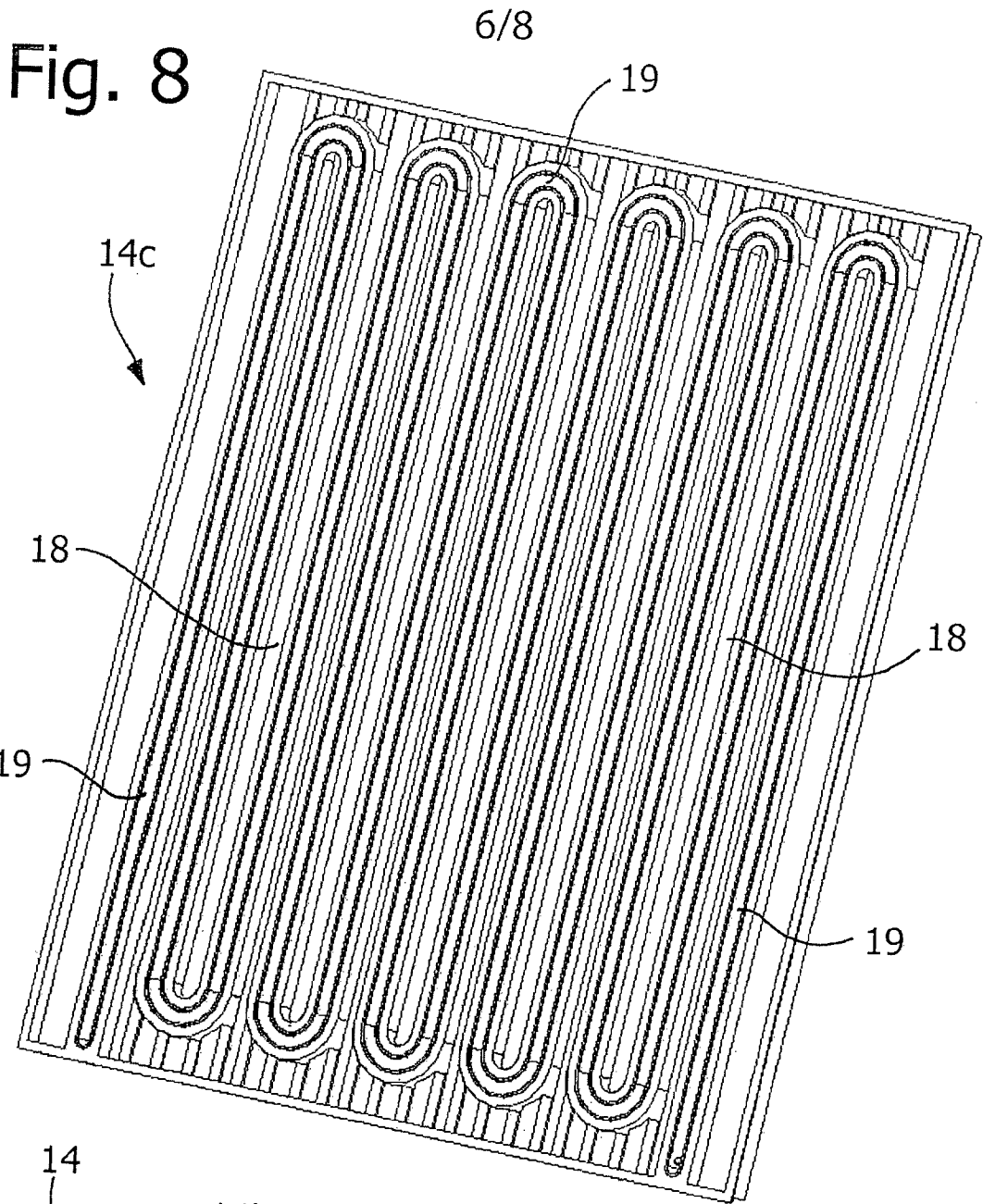

Fig. 9

Fig. 10

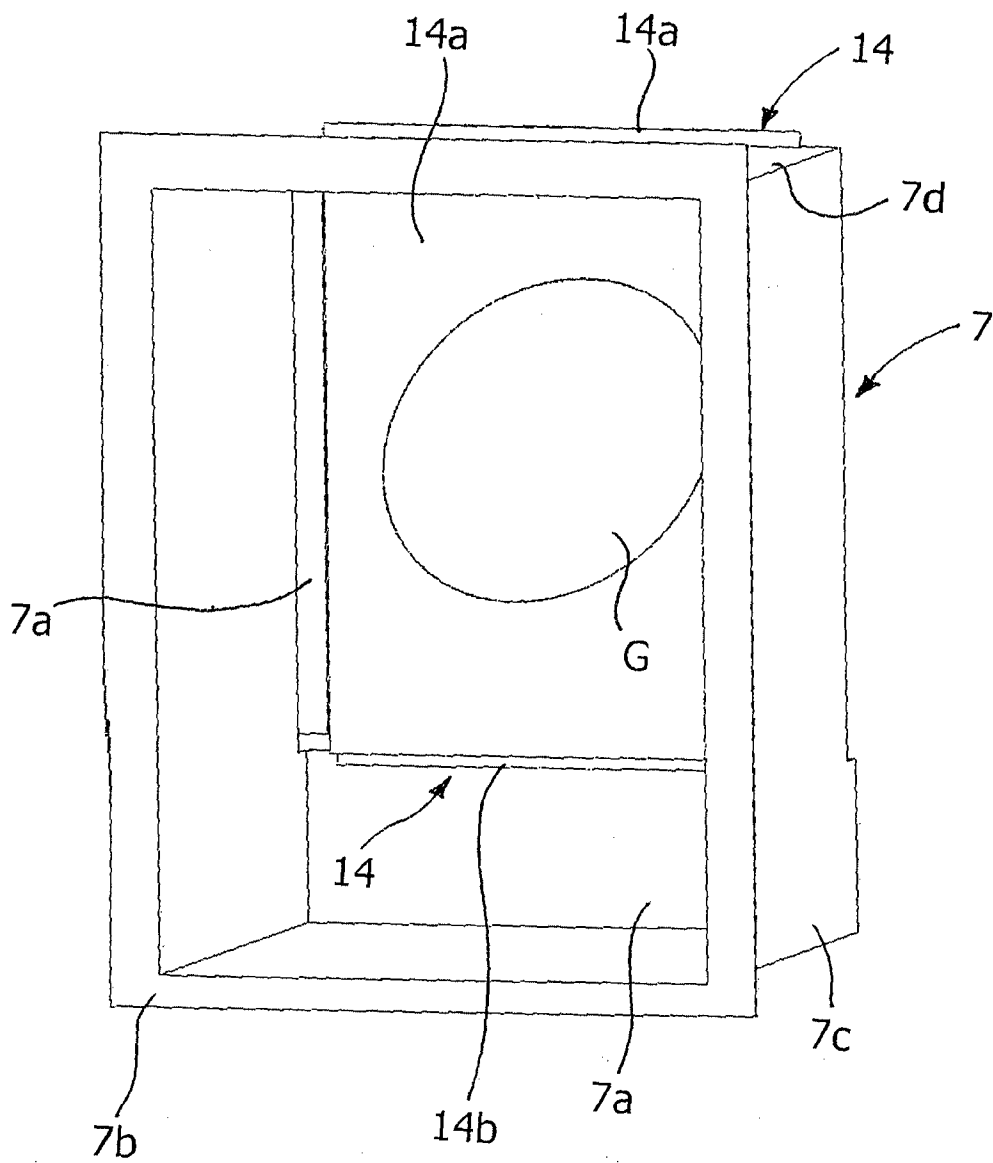

Fig. 11

