



(11) **EP 1 830 946 B1**

(12) **EUROPEAN PATENT SPECIFICATION**

(45) Date of publication and mention of the grant of the patent:
29.09.2010 Bulletin 2010/39

(51) Int Cl.:
B01F 13/10 ^(2006.01) **G07F 11/06** ^(2006.01)
G07F 11/64 ^(2006.01) **B65D 75/48** ^(2006.01)
B44D 3/06 ^(2006.01)

(21) Application number: **05826408.6**

(86) International application number:
PCT/EP2005/057083

(22) Date of filing: **22.12.2005**

(87) International publication number:
WO 2006/067206 (29.06.2006 Gazette 2006/26)

(54) **SYSTEM AND METHOD FOR COLORING PAINTS AND DECORATIVE COATINGS, AND RELATIVE ACTUATION DEVICE**

SYSTEM UND VERFAHREN ZUM FÄRBen VON LACKEN UND DEKORATIVEN BESCHICHTUNGEN UND ENTSPRECHENDE BETÄTIGUNGSVORRICHTUNG

SYSTEME ET PROCEDE PERMETTANT DE COLORER DES PEINTURES ET REVETEMENTS DECORATIFS, AINSI QUE DISPOSITIF D'ACTIONNEMENT CORRESPONDANT

(84) Designated Contracting States:
AT BE BG CH CY CZ DE DK EE ES FI FR GB GR HU IE IS IT LI LT LU LV MC NL PL PT RO SE SI SK TR

(72) Inventors:
• **SCARPETTA, Claudio**
I-35044 Montagnana (IT)
• **VERONESE, Francesco**
I-35042 Este (IT)

(30) Priority: **23.12.2004 IT UD20040238**

(74) Representative: **Petraz, Gilberto Luigi**
GLP S.r.l.
Piazzale Cavedalis 6/2
33100 Udine (IT)

(43) Date of publication of application:
12.09.2007 Bulletin 2007/37

(73) Proprietor: **M. V. Megatrade Ltd**
1075 Nicosia (CY)

(56) References cited:
FR-A- 1 081 825 US-A- 2 663 461
US-A- 5 836 661 US-A- 6 011 999

EP 1 830 946 B1

Note: Within nine months of the publication of the mention of the grant of the European patent in the European Patent Bulletin, any person may give notice to the European Patent Office of opposition to that patent, in accordance with the Implementing Regulations. Notice of opposition shall not be deemed to have been filed until the opposition fee has been paid. (Art. 99(1) European Patent Convention).

Description

FIELD OF THE INVENTION

5 **[0001]** The present invention concerns a manual tintometric system, a relative method and the device which allows said system to be actuated, for the rapid, precise and repeatable coloring of base paints and decorative coatings, for example white, which are made available for use, in a plurality of desired shades, by using single-dose packs of concentrated paste dye.

10 **[0002]** The invention concerns a system that uses single-dose packs of dyes based on single pigments, or pre-mixed, in order to obtain the coloring, according to a pre-determined arrangement, of one or more unitary known volumes of paints and coatings according to a finite and pre-determined plurality of different shades.

[0003] The invention also concerns a system that provides to use one or more single-dose packs in combination, according to a pre-determined arrangement, in order to easily obtain a potentially unlimited number of precise and reproducible shades, in which a high constancy of the result is guaranteed.

15 **[0004]** The paste dyes to which the invention refers are concentrated dispersions of pigment, ready for use and prepared in single-dose packs with a pre-established shape, type and capacity.

[0005] The base paints and/or coatings to which the invention refers are paints and/or coatings for decorative use, of any nature and type whatsoever (paints, washables, stuccoes, quartz coatings, lime-based, etc.), which are used in pre-established quantities consisting of a pre-determined number of unitary known volumes.

20 **[0006]** The base paints and/or coatings are supplied together with the single-dose packs, since the base paints can also be characterized by a pre-determined quantity of titanium dioxide and other white pigments which conditions the repeatable obtaining of the desired shades.

25 **[0007]** When the base paint/coating has been defined, the coloring system described here is valid and applicable irrespective of the characteristics of the base itself, in terms of content of titanium dioxide or other white pigments, and also of the level of coating and yield. The base paints and/or coatings to which the invention refers can therefore be white, medium or neutral, depending on the type of final effect that is to be obtained.

BACKGROUND OF THE INVENTION

30 **[0008]** It is known that, in the present state of the art, to color any paint and/or decorative coating in order to obtain a desired shade, one or another of the following modes is normally used:

i) by the manual coloring, drop by drop, of concentrated paste dyes, added gradually to the base paint until the desired shade is achieved;

35 ii) by manual coloring, dosing the paste dye according to weight in the base paint/coating;

iii) by means of volumetric and gravimetric tintometric systems, for example of the manual-mechanical, electronic and automatic type, which perform a pre-determined dosage of one or more dyes in the base paint/coating to be colored.

40 **[0009]** The main problem connected to the coloring of paints and decorative coatings concerns the continuous, exact and constant reproducibility of the tone of color desired. Coloring pastes of various nature are available on the market, and in packs of various capacity, which are added to and mixed with base paint products; this method of coloring does not, however, ensure a certain final result, since the result depends on the percentages of dye that are added to the base paint, on the characteristics of reproducibility of the dye and, not last although to a lesser extent, on the degree of whiteness of the paint product.

45 **[0010]** Therefore, in most cases, to have a good result it is necessary to rely on an expert, with results that are sometimes not optimum and in any case extremely subjective, since they depend on each occasion on the capacities of the individual.

50 **[0011]** An alternative is to use an automatic and computerized tintometric system which, however, requires that a thorough study of the paint is carried out upstream, and in any case this also requires expert personnel to be used.

[0012] If a non-expert decides to create for himself the tone of color desired, he encounters a series of problems due to the lack of knowledge of the dosage, the mixing process and the composition of the dyes.

55 **[0013]** Since the final result is uncertain and difficult to repeat with constancy, in the event that, after a period of time, it is necessary to touch up the paint or the decoration, or restore it, or extend it, it is very difficult to exactly reproduce the same color.

[0014] US-A-2.663.461 concerns single-dose packs to deliver pre-determined quantities of a particular substance, particularly medicines or suchlike.

[0015] FR-A-1.081.825, which discloses a system in accordance with the preamble of claim 1, a method in accordance

with the preamble of claim 18, and a device in accordance with the preamble of claim 23, concerns a method for preparing dyes for painting automobiles, in which single-dose packs of pigments are used, each one relating to a color of an automobile, but it does not concern a tintometric system of distributing to any user a single-dose pack of pigments to be used and/or combined together, and to be added to pre-determined quantities of a base paint/coating, in order to obtain in a repeatable and systematic way colored paints and coatings starting from a base paint or coating.

[0016] Purpose of the present invention is therefore to solve the problems described, guaranteeing the exact and constant reproducibility of the shades even for personnel who are not particularly expert, by using a coloring system that ensures easy use, rapid execution and extreme constancy and repeatability of results.

[0017] The Applicant has devised, tested and embodied the present invention to overcome the shortcomings of the state of the art and to obtain these and other purposes and advantages.

SUMMARY OF THE INVENTION

[0018] The present invention is set forth and characterized in the main claims, while the dependent claims describe other characteristics of the invention or variants to the main inventive idea.

[0019] In accordance with the above purpose, the present invention provides to pre-pack a plurality of concentrated paste dyes, based on defined pigments, or mixtures of pigments, each one contained in a single-dose pack of a pre-determined shape, type and capacity (volume).

[0020] Each of the single-dose packs allows a complete, immediate and constant dosage of the specific individual dye selected, in the base paint or decoration to which the desired shade is to be attributed.

[0021] The constancy of the result sought is obtained thanks to the fact that each of the single-dose packs contains a specific paste dye (as said, of the type with one or several pigments), pre-mixed at fixed percentages, which allows to achieve a finite range of pre-determined shades depending on the number of dyes required.

[0022] With the present invention, in one evolved embodiment, it is also possible to achieve a potentially unlimited range of shades, combining in a pre-ordained manner two or more single-dose packs of the same dye, in order to vary the tone of color within the same shade; or it is also possible to combine two or more single-dose packs of different dyes in order to obtain various combinations of new shades starting from a finite plurality of base dyes.

[0023] It is also provided to prepare the base paint/coating in unitary volumes (pre-defined packs and formats), so that, having chosen the base format (or quantity), it is possible to obtain with excellent reproducibility the shade reported for example in a color card, and deriving from a specific combination of one or more single-dose packs.

[0024] The maximum number of combinations that can be obtained, excluding the variability in the quantities of the base paint, can be calculated by the formula $k \cdot [(n+m) + (n \cdot m)]$, where n and m are equal to the number of individual dyes (single-dose packs) which can be combined together (with the individual dyes which can be the same as or different from each other), and k is the number of packs used in the mixture, according to a combination system that will be described in detail hereafter.

[0025] According to the invention, the dyes, pre-mixed in pastes and contained in the single-dose packs, can have one of the following generic combinations:

- a) pre-dispersed pigments in paste, with a defined or mixed color index, of both inorganic or organic type;
- b) dyes formulated in such a manner as to obtain both arbitrary shades, and also specific shades, for example coded internationally (for example RAL, NC, etc.).

[0026] In a preferential embodiment of the present invention, the pre-mixed paste dyes are prepared in single-dose packs having a usable capacity (volume) varying from 5 to 250 ml.

[0027] In another preferential embodiment, the single-dose pack is produced in plastic material (PE, LDPE, MDPE, HDPE, PET, PP, etc.) single or combined (for example aluminum-plastic, etc.).

[0028] In another preferential embodiment, the single-dose packs are produced by means of thermoforming starting from plastic laminates.

[0029] In another embodiment, the single-dose pack is produced in metal material.

[0030] In another preferential embodiment, each pack is provided with a suitable opening system, by cutting. The shape of the single-dose pack is advantageously designed to allow the content to be completely emptied, irrespective of alterations of a physical type (separation, etc.) that the content (dye) may suffer during extended storage.

[0031] According to the invention, the polymer material with which the single-dose pack is produced can be transparent, opaque or pigmented.

[0032] The system and the method according to the invention are advantageously actuated by means of a device which comprises a plurality of single-dose packs, each containing a pre-determined quantity of a single paste dye, at least a panel, or alternatively one or more color cards, carrying the shades of the dyes contained in the single-dose packs and the shades obtainable from the combinations of the single-dose packs, and at least a container in which a

plurality of tins of base paint/coating are positioned.

[0033] In this way, simply by identifying the desired shade on the panel or color card, the client purchases the format of base paint/coating and one or more single-dose packs to be added to the same base so as to achieve the combination corresponding to the desired shade.

[0034] According to an evolved form of embodiment of the present invention, the device also comprises a distribution machine, in which the single-dose packs are disposed, which automatically distributes, according to the user's requests, the specific packs needed to obtain the desired shade.

BRIEF DESCRIPTION OF THE DRAWINGS

[0035] These and other characteristics of the present invention will become apparent from the following description of some preferential forms of embodiment, given as a non-restrictive example with reference to the attached drawings wherein:

- fig. 1 is a schematic view of a first form of embodiment of a device to actuate the combined tintometric system according to the present invention;
- fig. 2 is a schematic view of a second form of embodiment of a device to actuate the combined tintometric system according to the present invention;
- figs. 3 to 9 show schematically some forms of embodiment of single-dose packs used in the distribution devices in figs. 1 or 2.

DETAILED DESCRIPTION OF SOME PREFERENTIAL FORMS OF EMBODIMENT

[0036] With reference to fig. 1, the reference number 10 indicates generally a distribution device to actuate a combined tintometric system according to the present invention.

[0037] In this case, the distribution device 10 is of the manual type and comprises a panel 11 and a box 14, the latter disposed below the panel 11.

[0038] The panel 11 is substantially divided into three boxes, respectively 12, 13 and 15, while the box 14 is open from the upper side and inside it a plurality of tins 18 are positioned, containing a determinate quantity of base paint/coating. The base paint/coating can be white, or of another type, for example medium or neutral.

[0039] The box 12 of the panel 11 is on the y axis, and a number n of pre-prepared single-dose packs 16 are positioned therein, for example hanging on hooks by means of holes of the Euroslot type. Each single-dose pack 16 contains a corresponding quantity of a base dye varying from about 5 ml to about 250 ml, denominated for example A-ochre, B-maize, C-pine, D-papaya, and others. In the same box 12 respective colored spaces 17 are provided, adjacent to the single-dose packs 16, which allow to display the color of the dye contained in the corresponding adjacent single-dose pack 16 and the use of the single-dose packs 16 in single or double quantity.

[0040] The box 13 is on the x axis and a number m of pre-prepared single-dose packs 16 are positioned therein, for example hanging on hooks by means of holes of the Euroslot type, as can be seen in figs. 3 to 9. Each single-dose pack 16 contains a corresponding quantity of a base dye varying from about 5 ml to about 250 ml, denominated for example 1-green, 2-earth, 3-iris, 4-mango, and others.

[0041] In this case too, below the single-dose packs 16, respective colored spaces 17 are provided, visually bearing the color of the dye contained in the corresponding single-dose pack 16 above, and the use of the single-dose pack 16 in single or double quantity.

[0042] The box 15 is disposed between the above mentioned boxes 12 and 13, and a plurality of colored spaces 19 are provided therein, which carry the graphic representation of the shade that can be obtained from the combination of one or more single-dose packs 16 disposed on the y axis with one or more single-dose packs 16 disposed on the x axis, and lying on the horizontal and vertical lines that cross in correspondence with said colored space 19.

[0043] Using the dye contained in the single-dose packs 16, the n + m dyes are used to obtain a number k·(n+m) of pre-determined shades and another k·(n·m) shades deriving from the combination thereof.

[0044] Therefore, when it is intended to mix a single-dose pack 16 disposed on the y axis with a single-dose pack 16 disposed on the x axis, the number k of shades will be equal to 2.

[0045] When it is intended to mix a single-dose pack 16 disposed on the y axis with two single-dose packs 16 disposed on the x axis, or vice versa, the number k of shades will be equal to 3.

[0046] As already indicated, in order to make immediately visible and intuitable the production of the shade for the most inexpert user, the shade obtainable from the combination of the individual single-dose packs 16 present respectively on the x axis and on the y axis is shown graphically exactly in correspondence with the intersection of the lines passing through the colored space 19 showing the desired shade.

[0047] The following table 1 graphically represents what has been described so far.

TABLE 1

n dyes etc.				
OCHRE	OCHRE + GREEN			
MAIZE			MAIZE + IRIS	
PINE				
PAPAYA				
PINK	GREEN	EARTH	IRIS	MANGO

5

10

15

20

25

30

35

40

45

50

55

[0048] etc. m dyes According to a variant not shown here, a different type of panel is used in which the single-dose packs 16 are disposed in a single file, for example below, above or laterally to the panel, and above the box 14. In this case, the single-dose packs 16 are stacked one on the other inside specific containers situated behind the panel and there is an aperture present towards the outside, for example located immediately below the panel, advantageously in correspondence with an abbreviation that identifies the content of the pack 16. In this way the single-dose packs 16 can easily be picked out by the user. Every time that a pack 16 is removed, a new pack is made available to the user in correspondence with the aperture.

[0049] With respect to the embodiment of fig. 1 as shown before, the panel does not carry the shades obtainable where the x axis and the y axis cross, but advantageously carries the formulas or recipes of all the shades obtainable from an arbitrary combination of the single-dose packs 16 combined with the panel.

[0050] With this solution, since the system teaches the user how to achieve any arbitrary type of combination of the single-dose packs 16 available, the number of shades obtainable from the combination of the packs 16 is much higher than the shades obtainable with the pre-determined combinations obtained in correspondence with the intersections of the panel 11 in fig. 1.

[0051] In the embodiment shown in fig. 2, a second form of preferential embodiment is shown of a distribution device, in this case indicated generally by the reference number 110, of an automatic or semi-automatic type.

[0052] The distribution device 110 comprises a panel 111, a box 114 and a distribution machine 120.

[0053] The panel 111, as in the previous case, has a number n of colored spaces 17 on the y axis, each bearing a determinate base color, and a number m of colored spaces 17 on the x axis, so as to define a number k of colored spaces 19 bearing the various shades obtainable from the combinations of the various base dyes. In this case too, the same considerations apply as were set forth concerning the shades obtainable from the combination of the base dyes. In this case too, the panel 111 can indicate, as an alternative to or in replacement of the shades obtainable in correspondence with the intersections of the x axis and y axis, all the shades obtainable from any arbitrary combination of the single-dose packs 16 available.

[0054] In this case, the pre-prepared single-dose packs 16 are disposed inside the distribution machine 120 which then provides to selectively distribute them according to the chosen shade.

[0055] The substantial difference with respect to the manual system is therefore due to the automated distribution of the single-dose packs 16.

[0056] In fact, in the completely manual system, once the shade has been identified the client directly picks up the single-dose pack or packs 16 hanging on the panel 11, or disposed on a side of or below the panel, while in the semi-automatic system the client identifies the shade in the same way on the panel 111, which is however marked by a progressive and defined number, or from a defined abbreviation/name.

[0057] In this way, the client keys in the number (or the abbreviation) corresponding to the chosen shade on a command panel 121 provided on the distribution machine 120 and, by means of a color monitor 122, the distribution machine 120 allows the faithful display of the selected shade.

[0058] At this point, if the selected number actually corresponds to the chosen shade, the client confirms the selection and the distribution machine 120 will supply one or more single-dose packs 16 relating to the desired shade.

[0059] The combined system according to the invention is therefore very efficient, since it is enough to load the distribution machine 120 with a rather limited number of different base dyes, in order to obtain from their combination a large number of shades.

[0060] According to a first variant, not shown here, the distribution machine 120 can be implemented with a command panel 121 of the palm type, that is, the panel 111 is shown directly on the monitor 122, so that the user can move left and right along the line of m dyes to select the one desired, and along the column of n dyes to perform the selection.

[0061] Once positioned in correspondence with the shade desired, the user can press a selection key, or press the

screen directly in correspondence with the shade.

[0062] The selection thus effected determines the expulsion of the selected single-dose pack 16, or of several single-dose packs 16 even different, to be used in combination to obtain the desired shade.

[0063] In this embodiment, it is also possible to select the quantity of base paint if this is divided into unitary quantities, for example in the event that in the box 114 there are tins 18 of different capacity, for example 4 liters and 10 liters. Moreover, the possibility may be provided to select the base paint, should the shades have been designed for two or more base coatings with different characteristics, for example in terms of degree of white, cover, chemical composition and other.

[0064] According to another variant, a completely automated distribution device 110 is provided, in which all the shades on the panel 111 are distinguished by an abbreviation or a defined number, so that they can be selected on the distribution machine 120. In this case, since the number of base shades is not restricted, given that the machine effects the dosage of the dyes inside itself, the panel showing the shades can be analogous to the panel 111 or it can carry an indefinite number of shades of any type. The distribution machine 120 does not contain inside any already pre-packed single-dose packs 16, but the single-dose packs 16 are prepared at the moment, inside the distribution machine 120, by delivering paste dyes.

[0065] The functioning of the distribution machine 120 is therefore similar to that used for automatic distributors of instant hot drinks.

[0066] In this case, the distribution machine 120, following the selection by the client, supplies one single-dose pack 16 of paste dye, the composition and quantity of which is prepared at the moment, thus also reducing the limits of capacity for the single-dose pack 16.

[0067] In this case, the distribution machine 120 comprises inside a device for the application of a label on the single-dose pack 16. The label can for example contain the following data:

- number and name of the shade;
- packing date and traceability of the product (to respect the laws in force concerning labeling and "General safety of products"); and/or
- bar code and price of the product.

[0068] In this case, the distribution machine 120 also comprises inside a series of containers for the paste dyes and an electronic delivery system totally analogous to the usual electronic and automatic tintometric systems present on the market.

[0069] In this way the distribution machine 120 delivers the mixture of dyes in a single-dose pack 16, closes it hermetically, applies the complete label and then expels it.

[0070] The substantial difference with respect to tintometric systems currently present on the market is the considerable simplicity of use of the distribution device both manual 10 or automated 110, without any assistance from specialized personnel. At present, in fact, in order to color a base paint by means of an automatic tintometric system, the client has to be assisted by specialized personnel. Once having chosen the shade and the base paint, the client informs the specialized assistant, who effects the operations to add the dye and subsequent mixing with the base paint.

[0071] The system described in the present invention, on the contrary, does not require the assistance of specialized personnel, since the client only has to select the shade combined with a determinate base paint, pick up the single-dose pack 16 and then carry out the mixing for himself. The specialized personnel will only have to perform the maintenance of the distribution device 10, 110 from time to time, exclusively to top up the single-dose packs 16 and the tins 18 of the base paint, and to carry out the ordinary cleaning of the possible nozzles and the delivery system.

[0072] The system according to the invention is therefore particularly suitable for the less expert user, who can thus choose the desired shade from a sample of shades displayed graphically on the panel 11, 11 and, mixing the single-dose packs 16 with the base paint contained in the tins 18, can obtain the desired result, with certainty, constancy and repeatability.

[0073] As an alternative to the panel 11 or 111, the machine could distribute and/or display color cards, which can be consulted manually, on which the combinations obtainable starting from the single-dose packs 16 available on the machine are reported. This solution is advantageously applicable in cases where, for reasons of space, it is not possible to use machines equipped with panels of a certain size.

[0074] Figs. 3 to 9 show some of the possible variants of single-dose packs 16 provided in the system according to the invention. Generally, all the embodiments of single-dose packs 16a, 16b, 16c, 16d, 16e, 16f and 16g, as described hereafter, can be made irrespectively of transparent, opaque or pigmented plastic material, such as PE, LDPE, MDPE, HDPE, PET, PP or other, single or combined, by means of thermoforming, and are provided with a cutting opening system. The single-dose packs can also be made of metal material, for example aluminum, or multiple combined.

[0075] To be more exact, figs. 3, 4, 5 and 6 show single-dose packs 16a, 16b, 16c and 16d made of polymer material, either in the form of a flexible bag, made of impermeable plastic, or multiple combined.

[0076] In fig. 7, the single-dose pack 16e is made in the form of a sachet made of impermeable plastic material, or multiple combined, such as for example aluminum-plastic, Tetrapack®, or suchlike.

[0077] Fig. 8 shows an embodiment wherein the single-dose pack 16f is made in the form of a tube of polymer material, multiple combined or metal, for example aluminum, equipped with a screw top and closed at the end by means of heat welding.

[0078] According to another variant shown in fig. 9, the single-dose pack 16g can also be made in the form of a dosing syringe.

[0079] It is clear that modifications and/or additions of parts may be made to what has been described heretofore, without departing from the scope of the present invention.

[0080] For example, it comes within the field of the invention that the device 10 can also be used without the base paints/coatings, but only to combine together two or more single-dose packs 16 in order to obtain a desired and pre-determined shade, for example indicated on the panel or on a relative color card.

[0081] It is also clear that, although the present invention has been described with reference to some specific examples, a person of skill in the art shall certainly be able to achieve many other equivalent forms of systems and methods for coloring paints and decorative coatings, and relative actuation devices, having the characteristics as set forth in the claims and hence all coming within the field of protection defined thereby.

Claims

1. System for coloring paints and decorative coatings, comprising:

- a plurality of single-dose packs (16), each containing a pre-determined quantity of a single paste dye, **characterized in that** it further comprises
- a container (14) inside which a plurality of tins containing a determinate quantity of a base paint or decorative coating are positioned;

and **in that** one or more single-dose packs (16) of one or more of said individual dyes is suitable to be added, according to a combinatorial arrangement, to a pre-determined quantity consisting of one or more of said quantities of said base paint or decorative coating in order to attribute to said resulting paint, or decorative coating, a specific desired shade according to constant and repeatable modes, the system further comprising a panel (11, 111) or color cards wherein a graphic representation (19) is provided of the shade that can be obtained from the combination of one or more single-dose packs (16).

2. System as in claim 1, **characterized in that** said base paint or decorative coating is a paint product of any type and nature, containing or not containing titanium dioxide and other white pigments.

3. System as in claim 1 or 2, **characterized in that** said paste dye consists of a single dye pigment.

4. System as in claim 1 or 2, **characterized in that** said paste dye consists of two or more pre-mixed pigments.

5. System as in claim 1, **characterized in that** said pre-determined quantity of paste dye for each single-dose pack (16) is comprised between 5 and 250 ml.

6. System as in any claim hereinbefore, **characterized in that** two or more of said single-dose packs (16) of a same paste dye are suitable to be added, according to a pre-determined arrangement, to a pre-determined quantity of a base paint or decorative coating in order to attribute to said paint or decorative coating a different tone of the same shade, said tone varying in a constant and repeatable manner according to the number of single-dose packs (16) used.

7. System as in any claim from 1 to 5, **characterized in that** two or more of said single-dose packs (16), each containing a different paste dye, are suitable to be added, according to a pre-determined arrangement, to a pre-determined quantity of a base paint or decorative coating in order to attribute to said base paint or decorative coating, in a constant and repeatable manner, a shade obtained from the combination of said two or more different paste dyes.

8. System as in any claim hereinbefore, **characterized in that** two or more single-dose packs (16) of two or more paste dyes are suitable to be combined together in order to obtain a desired shade.

9. System as in any claim hereinbefore, **characterized in that** said single-dose packs (16) are produced in plastic

material (PE, LDPE, MDPE, HDPE, PET, PP), single or combined, or in metal material.

- 5
10. System as in any claim hereinbefore, **characterized in that** said single-dose packs (16) are produced by means of thermoforming starting from plastic laminates.
11. System as in any claim hereinbefore, **characterized in that** each of said single-dose packs (16) is provided with a cutting opening system.
- 10 12. System as in any claim hereinbefore, **characterized in that** the single-dose pack (16) is produced in transparent, opaque or pigmented polymer material.
13. System as in any claim hereinbefore from 1 to 8, **characterized in that** each of said single-dose packs (16a, 16b, 16c, 16d) is a flexible bag, made of impermeable plastic material or multiple combined.
- 15 14. System as in any claim from 1 to 12, **characterized in that** said single-dose pack (16e) is made in the form of a sachet of impermeable or multiple combined plastic material, such as for example aluminum-plastic, Tetrapack® or suchlike.
- 20 15. System as in any claim hereinbefore, **characterized in that** each of said single-dose packs (16a, 16b, 16c, 16d) is equipped with a Euroslot hole to allow it to be set up on hooks or suchlike.
16. System as in any claim from 1 to 12, **characterized in that** said single-dose pack (16f) is a tube of polymer material, multiple combined or metal, equipped with a screw top and closed at the end by means of heat welding.
- 25 17. System as in any claim from 1 to 12, **characterized in that** said single-dose pack (16g) is a dosing syringe made of polymer material, finalized for the complete emptying of the content.
- 30 18. Method for coloring paints and decorative coatings, wherein it provides to pack a plurality of concentrated paste dyes, based on defined pigments, or mixtures of pigments, each contained in a single-dose pack (16) of a pre-determined shape, type and capacity, **characterized in that** it provides a container (14) inside which a plurality of tins (18) containing a determinate quantity of a base paint or decorative coating are positioned; and **in that** it provides to associate at least one of said paste dyes, according to a pre-determined arrangement, with a pre-determined quantity consisting of one or more of said quantity of said base paint or decorative coating in order to attribute to said paint or decorative coating a specific shade according to constant and repeatable modes, and wherein a user can choose the desired shade from a sample of shade displayed by a graphic representation (19) provided either on a panel (11, 111) or on color cards of the shade that can be obtained from the combination of one or more single-dose packs (16).
- 35
- 40 19. Method as in claim 18, **characterized in that** it provides to use two or more single-dose packs (16) of the same paste dye in order to obtain the same shade with a varying tone in a repeatable manner, according to the number of single-dose packs (16) used.
- 45 20. Method as in claim 18, **characterized in that** it provides to use two or more single-dose packs (16), each with a different paste dye, in order to obtain in a constant and repeatable manner a new shade deriving from the combination of said two or more dyes.
21. Method as in any claim from 18 to 20, **characterized in that** each of said single-dose packs (16) is picked up manually by the user from a panel (11) with which they are associated.
- 50 22. Method as in any claim from 18 to 20, **characterized in that** each of said single-dose packs (16) is delivered automatically by a distribution machine (120) in which said single-dose packs (16) are disposed.
- 55 23. Device for coloring paints and decorative coatings, wherein it comprises a plurality of single-dose packs (16), each containing a pre-determined quantity of a single paste dye, **characterized in that** it comprises a container (14) inside which a plurality of tins (18) containing a determinate quantity of base paint or decorative coating are positioned, and at least a panel (11, 111) bearing the shades of the dyes contained in said single-dose packs (16) and the shades obtainable, according to a pre-determined arrangement, from the combinations of said single-dose packs (16), and at least a container (14) in which said tins (18) comprising said one or more unitary quantities of said base

paint or decorative coating are positioned, wherein said panel (11, 111) comprises a plurality of colored spaces (19) or of color cards which carry the graphic representation of the shade that can be obtained from the combination of one or more single-dose packs (16).

- 5 **24.** Device as in claim 23, **characterized in that** it also comprises a distribution machine (120) able to automatically distribute said single-dose packs (16) in order to obtain a desired shade.
- 10 **25.** Device as in claim 24, **characterized in that** said distribution machine (120) is able to deliver one or more pre-packed single-dose packs (16).
- 15 **26.** Device as in claim 25, **characterized in that** said distribution machine (120) is able to deliver a single-dose pack (16), prepared and sealed at the moment starting from paste dyes, applying or printing on the same single-dose pack the references relating to the shade (content, bar code, price, etc.).
- 20 **27.** Device as in any claim from 23 to 26, **characterized in that** said distribution machine (120) comprises command and display means (121, 122) able to allow the user to select and display said desired shade.
- 25 **28.** Device as in any claim from 23 to 25, **characterized in that** it comprises means to distribute or display a color card carrying the shades of the dyes contained in said single-dose packs (16) and the shades obtainable, according to a pre-determined arrangement, from the combinations of said single-dose packs (16).
- 30 **29.** Device as in claim 23, **characterized in that** said single-dose packs (16) are disposed on said panel (11) in positions adjacent to the shades corresponding to the dye contained therein.
- 35 **30.** Device as in claim 23, **characterized in that** said single-dose packs (16) are disposed below the panel (11, 111) and stacked inside containers.

Patentansprüche

- 30 **1.** System zum Färben von Lacken und Dekorationsbeschichtungen, aufweisend:
- 35 - eine Mehrzahl von Einzeldosis-Packungen (16), die jeweils eine vorbestimmte Menge eines einzigen Pastenfarbstoffes enthalten,
- 40 **dadurch gekennzeichnet, dass** es ferner aufweist:
- 45 - einen Behälter (14), in dem eine Mehrzahl von Dosen positioniert ist, die eine bestimmte Menge eines Basislacks oder einer Basis-Dekorationsbeschichtung enthalten,
- 50 und dass eine oder mehr Einzeldosis-Packungen (16) mit einem oder mehr der einzelnen Farbstoffe geeignet ist/ sind, gemäß einer Kombinationsanordnung zu einer vorbestimmten Menge hinzugefügt zu werden, die aus einer oder mehr der Mengen des Basislacks oder der Basis-Dekorationsbeschichtung besteht, um dem/der sich ergebenden Lack oder Dekorationsbeschichtung konstanten und wiederholbaren Arten entsprechend eine bestimmte gewünschte Farbschattierung zu geben, wobei das System ferner aufweist: ein Paneel (11, 111) oder Farbkarten, wobei eine grafische Darstellung (19) der Farbschattierung, die aus der Kombination einer oder mehrerer Einzeldosis-Packungen (16) erhalten werden kann, bereitgestellt wird.
- 55 **2.** System gemäß Anspruch 1, **dadurch gekennzeichnet, dass** der Basislack oder die Basis-Dekorationsbeschichtung ein Farbprodukt jeder Art und Beschaffenheit ist, das Titandioxid und andere weiße Pigmente enthält oder nicht enthält.
- 60 **3.** System gemäß Anspruch 1 oder 2, **dadurch gekennzeichnet, dass** der Pastenfarbstoff aus einem einzigen Farbstoffpigment besteht.
- 65 **4.** System gemäß Anspruch 1 oder 2, **dadurch gekennzeichnet, dass** der Pastenfarbstoff aus zwei oder mehr vorgemischten Pigmenten besteht.

5. System gemäß Anspruch 1, **dadurch gekennzeichnet, dass** die vorbestimmte Menge an Pastenfarbstoff für jede Einzeldosis-Packung (16) zwischen 5 ml und 250 ml liegt.
6. System gemäß irgendeinem vorherigen Anspruch, **dadurch gekennzeichnet, dass** zwei oder mehr der Einzeldosis-Packungen (16) eines gleichen Pastenfarbstoffes geeignet sind, gemäß einer vorbestimmten Anordnung zu einer vorbestimmten Menge eines Basislacks oder einer Basis-Dekorationsbeschichtung hinzugefügt zu werden, um dem Lack oder der Dekorationsbeschichtung einen anderen Farbton der gleichen Farbschattierung zu geben, wobei der Farbton auf konstante und wiederholbare Weise der Anzahl an verwendeten Einzeldosis-Packungen (16) entsprechend variiert.
7. System gemäß irgendeinem Anspruch von 1 bis 5, **dadurch gekennzeichnet, dass** zwei oder mehr der Einzeldosis-Packungen (16), die jeweils einen unterschiedlichen Pastenfarbstoff enthalten, geeignet sind, gemäß einer vorbestimmten Anordnung einer vorbestimmten Menge eines Basislacks oder einer Basis-Dekorationsbeschichtung beigefügt zu werden, um dem Basislack oder der Basis-Dekorationsbeschichtung auf eine konstante und wiederholbare Weise eine Farbschattierung zu geben, die aus der Kombination der zwei oder mehr unterschiedlichen Pastenfarbstoffe erhalten wird.
8. System gemäß irgendeinem vorhergehenden Anspruch, **dadurch gekennzeichnet, dass** zwei oder mehr Einzeldosis-Packungen (16) von zwei oder mehr Pastenfarbstoffen geeignet sind, miteinander kombiniert zu werden, um eine gewünschte Farbschattierung zu erhalten.
9. System gemäß irgendeinem vorhergehenden Anspruch, **dadurch gekennzeichnet, dass** die Einzeldosis-Packungen (16) aus Kunststoff (PE, LDPE, MDPE, HDPE, PET, PP), einzeln oder kombiniert, oder aus Metallwerkstoff hergestellt sind.
10. System gemäß irgendeinem vorhergehenden Anspruch, **dadurch gekennzeichnet, dass** die Einzeldosis-Packungen (16) mittels Thermoformens ausgehend von Kunststofflaminate hergestellt sind.
11. System gemäß irgendeinem vorhergehenden Anspruch, **dadurch gekennzeichnet, dass** jede der Einzeldosis-Packungen (16) mit einem Aufschneide-Öffnungssystem versehen ist.
12. System gemäß irgendeinem vorhergehenden Anspruch, **dadurch gekennzeichnet, dass** die Einzeldosis-Packung (16) aus durchsichtigem, lichtundurchlässigem oder pigmentiertem Polymerwerkstoff hergestellt ist.
13. System gemäß irgendeinem vorhergehenden Anspruch 1 bis 8, **dadurch gekennzeichnet, dass** jede der Einzeldosis-Packungen (16a, 16b, 16c, 16d) ein flexibler Beutel ist, der aus undurchlässigem Kunststoff hergestellt oder mehrfach kombiniert ist.
14. System gemäß irgendeinem Anspruch von 1 bis 12, **dadurch gekennzeichnet, dass** die Einzeldosis-Packung (16e) in Form eines Portionsbeutels aus undurchlässigem oder mehrfach kombiniertem Kunststoff, wie zum Beispiel aus Aluminium-Kunststoff, TetraPak® oder dergleichen hergestellt ist.
15. System gemäß irgendeinem vorhergehenden Anspruch, **dadurch gekennzeichnet, dass** jede der Einzeldosis-Packungen (16a, 16b, 16c, 16d) mit einem Euroschlitz-Loch versehen ist, um zu ermöglichen, dass diese auf Haken oder dergleichen aufgesetzt wird.
16. System gemäß irgendeinem Anspruch von 1 bis 12, **dadurch gekennzeichnet, dass** die Einzeldosis-Packung (16f) ein Rohr aus einem Polymerwerkstoff, mehrfach kombiniert oder aus Metall ist, das mit einem Schraubverschluss ausgestattet ist und am Ende mittels Heißschweißens verschlossen ist.
17. System gemäß irgendeinem Anspruch von 1 bis 12, **dadurch gekennzeichnet, dass** die Einzeldosis-Packung (16g) eine aus Polymerwerkstoff hergestellte Dosierspritze ist, die für das vollständige Leeren des Inhaltes ausgearbeitet ist.
18. Verfahren zum Färben von Lacken und Dekorationsbeschichtungen, wobei es das Verpacken einer Mehrzahl von konzentrierten Pastenfarbstoffen basierend auf definierten Pigmenten oder Pigmentmischungen bereitstellt, die jeweils in einer Einzeldosis-Packung (16) einer vorbestimmten Form, Art und Kapazität enthalten sind, **dadurch gekennzeichnet, dass** es einen Behälter (14) bereitstellt, in dem eine Mehrzahl von Dosen (18) positioniert ist, die

- eine vorbestimmte Menge eines Basislacks oder einer Basis-Dekorationsbeschichtung enthalten, und dass es das Zuordnen mindestens eines der Pastenfarbstoffe gemäß einer vorbestimmten Anordnung zu einer vorbestimmten Menge bestehend aus einer oder mehr der Menge des Basislacks oder der Basis-Dekorationsbeschichtung bereitstellt, um dem Lack oder der Dekorationsbeschichtung eine bestimmte Farbschattierung konstanten und wiederholbaren Arten entsprechend zu geben, und wobei ein Benutzer die gewünschte Farbschattierung aus einem Schattierungsmuster auswählen kann, das mittels einer grafischen Darstellung (19) angezeigt wird, die entweder auf einem Paneel (11, 111) oder auf Farbkarten mit der Farbschattierung bereitgestellt wird, die aus der Kombination von einer mehreren Einzeldosis-Packungen (16) erhalten werden kann.
- 5
- 10 **19.** Verfahren gemäß Anspruch 18, **dadurch gekennzeichnet, dass** es das Verwenden von zwei oder mehr Einzeldosis-Packungen (16) des gleichen Pastenfarbstoffes bereitstellt, um die gleiche Farbschattierung mit einem variierenden Farbton auf eine wiederholbare Weise entsprechend der Anzahl von verwendeten Einzeldosis-Packungen (16) zu erhalten.
- 15 **20.** Verfahren gemäß Anspruch 18, **dadurch gekennzeichnet, dass** es das Verwenden von zwei oder mehr Einzeldosis-Packungen (16) jeweils mit einem unterschiedlichen Pastenfarbstoff bereitstellt, um auf eine konstante und wiederholbare Weise eine sich aus der Kombination der zwei oder mehr Farbstoffe ergebende neue Farbschattierung zu erhalten.
- 20 **21.** Verfahren gemäß irgendeinem Anspruch von 18 bis 20, **dadurch gekennzeichnet, dass** jede der Einzeldosis-Packungen (16) von dem Benutzer aus einem Paneel (11), dem diese zugeordnet sind, von Hand aufgenommen wird.
- 25 **22.** Verfahren gemäß irgendeinem Anspruch von 18 bis 20, **dadurch gekennzeichnet, dass** jede der Einzeldosis-Packungen (16) automatisch von einer Verteilermaschine (120) ausgegeben wird, in der die Einzeldosis-Packungen (16) angeordnet sind.
- 30 **23.** Vorrichtung zum Färben von Lacken und Dekorationsbeschichtungen, wobei sie eine Mehrzahl von Einzeldosis-Packungen (16) aufweist, die jeweils eine vorbestimmte Menge eines einzigen Pastenfarbstoffes enthalten, **dadurch gekennzeichnet, dass** sie aufweist: einen Behälter (14), in dem eine Mehrzahl von Dosen (18) positioniert ist, die eine bestimmte Menge an Basislack oder Basis-Dekorationsbeschichtung aufweisen, und mindestens ein Paneel (11, 111), das die Farbschattierungen der in den Einzeldosis-Packungen (16) enthaltenen Farbstoffe und die Farbschattierungen trägt, die gemäß einer vorbestimmten Anordnung aus den Kombinationen der Einzeldosis-Packungen (16) erhältlich sind, und mindestens einen Behälter (14), in dem die Dosen (18) positioniert sind, die eine oder mehrere einheitliche Mengen des Basislacks oder der Basis-Dekorationsbeschichtung aufweisen, wobei das Paneel (11, 111) eine Mehrzahl von Farbräumen (19) oder Farbkarten aufweist, die die grafische Darstellung der Farbschattierung tragen, die aus der Kombination von einer oder mehreren Einzeldosis-Packungen (16) erhalten werden kann.
- 35
- 40 **24.** Vorrichtung gemäß Anspruch 23, **dadurch gekennzeichnet, dass** sie auch eine Verteilermaschine (120) aufweist, die geeignet ist, die Einzeldosis-Packungen (16) automatisch zu verteilen, um eine gewünschte Farbschattierung zu erhalten.
- 45 **25.** Vorrichtung gemäß Anspruch 24, **dadurch gekennzeichnet, dass** die Verteilermaschine (120) geeignet ist, eine oder mehr vorverpackte Einzeldosis-Packungen (16) auszugeben.
- 50 **26.** Vorrichtung gemäß Anspruch 25, **dadurch gekennzeichnet, dass** die Verteilermaschine (120) geeignet ist, eine Einzeldosis-Packung (16) auszugeben, die zu dem Zeitpunkt beginnend mit den Pastenfarbstoffen vorbereitet und versiegelt wird, wobei die Hinweise bezüglich der Schattierung (Inhalt, Strichcode, Preis und so weiter) auf die gleiche Einzeldosis-Packung aufgebracht oder aufgedruckt werden.
- 55 **27.** Vorrichtung gemäß irgendeinem Anspruch von 23 bis 26, **dadurch gekennzeichnet, dass** die Verteilermaschine (120) Befehls- und Anzeigemittel (121, 122) aufweist, die geeignet sind, dem Benutzer zu ermöglichen, die gewünschte Farbschattierung auszuwählen und anzuzeigen.
- 28.** Vorrichtung gemäß irgendeinem Anspruch von 23 bis 25, **dadurch gekennzeichnet, dass** sie Mittel aufweist zum Verteilen oder Anzeigen einer Farbkarte, die die Farbschattierungen der in den Einzeldosis-Packungen (16) enthaltenen Farbstoffe sowie die Farbschattierungen trägt, die gemäß einer vorbestimmten Anordnung aus den Kombinationen der Einzeldosis-Packungen (16) erhältlich sind.

29. Vorrichtung gemäß Anspruch 23, **dadurch gekennzeichnet, dass** die Einzeldosis-Packungen (16) auf dem Paneel (11) in Positionen benachbart zu den Farbschattierungen angeordnet sind, die dem darin enthaltenen Farbstoff entsprechen.

5 30. Vorrichtung gemäß Anspruch 23, **dadurch gekennzeichnet, dass** die Einzeldosis-Packungen (16) unter dem Paneel (11, 111) angeordnet und in Behältern übereinandergestapelt sind.

Revendications

10

1. Système de coloration de peintures et de revêtements décoratifs, comprenant :

- une pluralité de paquets d'une seule dose (16), chacun contenant une quantité prédéterminée d'un seul colorant en pâte, **caractérisé en ce qu'il** comprend en outre :

15

- un conteneur (14) à l'intérieur duquel une pluralité de pots contenant une quantité déterminée d'une peinture de base ou d'un revêtement décoratif sont positionnés ;

20

et **en ce que** un ou plusieurs desdits paquets d'une seule dose (16) d'un ou plusieurs desdits colorants individuels convient(conviennent) pour être ajouté(s), selon un agencement de combinaison, à une quantité prédéterminée consistant en une ou plusieurs desdites quantités de ladite peinture de base ou du dit revêtement décoratif afin d'attribuer à ladite peinture ou au dit revêtement décoratif résultant(e), une nuance spécifique désirée selon des modes constants et reproductibles, le système comprenant en outre un panneau (11, 111) ou des cartes de couleur sur lequel/lesquelles une représentation graphique (19) est fournie de la nuance qui peut être obtenue à partir de

25

la combinaison d'un ou de plusieurs paquets d'une seule dose (16).

30

2. Système selon la revendication 1, **caractérisé en ce que** ladite peinture de base ou ledit revêtement décoratif est un produit de peinture d'un type et d'une nature quelconques, contenant, ou ne contenant pas, du dioxyde de titane et d'autres pigments blancs.

35

3. Système selon la revendication 1 ou 2, **caractérisé en ce que** ledit colorant en pâte consiste en un seul pigment blanc.

4. Système selon la revendication 1 ou 2, **caractérisé en ce que** ledit colorant en pâte consiste en deux, ou plusieurs pigments pré-mélangés.

40

6. Système selon l'une quelconque des revendications précédentes, **caractérisé en ce que** deux ou plusieurs desdits paquets d'une seule dose (16) d'un même colorant en pâte conviennent pour être ajoutés, selon un agencement prédéterminé, à une quantité prédéterminée d'une peinture de base ou d'un revêtement décoratif afin d'attribuer à ladite peinture ou au dit revêtement décoratif un ton différent de la même nuance, ledit ton variant de manière constante et reproductible, selon le nombre de paquets d'une seule dose (16) utilisés.

45

7. Système selon l'une quelconque des revendications 1 à 5, **caractérisé en ce que** deux ou plusieurs desdits paquets d'une seule dose (16), chacun contenant un colorant en pâte différent, conviennent pour être ajoutés, selon un agencement prédéterminé, à une quantité prédéterminée d'une peinture de base et d'un revêtement décoratif, afin d'attribuer à ladite peinture de base ou au dit revêtement décoratif, d'une manière constante et reproductible, une nuance obtenue à partir de la combinaison desdits deux ou plusieurs colorants en pâte différents.

50

8. Système selon l'une quelconque des revendications précédentes, **caractérisé en ce que** deux ou plusieurs desdits paquets d'une seule dose (16) de deux ou plusieurs colorants en pâte conviennent pour être combinés ensemble afin d'obtenir une nuance désirée.

55

9. Système selon l'une quelconque des revendications précédentes, **caractérisé en ce que** lesdits paquets d'une seule dose (16) sont fabriqués dans une matière plastique (PE, LDPE, MDPE, HDPE, PET, PP), unique ou combinée, ou dans un matériau métallique.

EP 1 830 946 B1

10. Système selon l'une quelconque des revendications précédentes, **caractérisé en ce que** lesdits paquets d'une seule dose (16) sont fabriqués par thermoformage à partir de laminés de plastique.
- 5 11. Système selon l'une quelconque des revendications précédentes, **caractérisé en ce que** chacun desdits paquets d'une seule dose (16) est muni d'un système d'ouverture par découpe.
12. Système selon l'une quelconque des revendications précédentes, **caractérisé en ce que** le paquet d'une seule dose (16) est fabriqué dans un matériau polymère transparent, opaque ou pigmenté.
- 10 13. Système selon l'une quelconque des revendications précédentes 1 à 8, **caractérisé en ce que** chacun desdits paquets d'une seule dose (16a, 16b, 16c, 16d) est un sachet souple, composé d'une matière plastique imperméable ou de matière plastique multiple combinée.
- 15 14. Système selon l'une quelconque des revendications 1 à 12, **caractérisé en ce que** ledit paquet d'une seule dose (16e) a la forme d'un sachet composé de matière plastique imperméable ou de matière plastique multiple combinée, telle que, par exemple, aluminium-plastique, Tetrapack® ou similaire.
- 20 15. Système selon l'une quelconque des revendications précédentes, **caractérisé en ce que** chacun desdits paquets d'une seule dose (16a, 16b, 16c, 16d) est muni d'une fente Euroslot pour lui permettre d'être installé sur des crochets ou similaire.
- 25 16. Système selon l'une quelconque des revendications 1 à 12, **caractérisé en ce que** ledit paquet d'une seule dose (16f) est un tube composé d'un matériau polymère, d'une matière plastique multiple combinée ou d'un métal, muni d'un couvercle à vis et refermé, à l'extrémité, par thermosoudage.
- 30 17. Système selon l'une quelconque des revendications 1 à 12, **caractérisé en ce que** ledit paquet d'une seule dose (16g) est une seringue de dosage composée d'un matériau polymère, conçue pour la vidange complète du contenu.
- 35 18. Procédé de coloration de peintures et de revêtements décoratifs, dans lequel il est proposé d'emballer une pluralité de colorants en pâte concentrés, à base de pigments définis, ou de mélanges de pigments, chacun étant contenu dans un paquet d'une seule dose (16) ayant une forme, un type et une capacité prédéterminés, **caractérisé en ce qu'il** est proposé un conteneur (14) à l'intérieur duquel une pluralité de pots (18) contenant une quantité prédéterminée d'une peinture de base ou d'un revêtement décoratif sont positionnés ; et **en ce qu'il** est proposé d'associer au moins l'un desdits colorants en pâte, selon un agencement prédéterminé, avec une quantité prédéterminée consistant en l'une ou en plusieurs desdites quantités de la peinture de base ou dudit revêtement décoratif, pour attribuer à ladite peinture ou au dit revêtement décoratif une nuance spécifique selon des modes constants et reproductibles, et dans lequel un utilisateur peut choisir la nuance désirée à partir d'un échantillon de la nuance affichée par une représentation graphique (19) fournie soit sur un panneau (11, 111) soit sur des cartes de couleur de la nuance qui peut être obtenue à partir de la combinaison d'un ou de plusieurs paquets d'une seule dose (16).
- 40 19. Procédé selon la revendication 18, **caractérisé en ce qu'il** est proposé d'utiliser deux, ou plusieurs, paquets d'une seule dose (16) du même colorant en pâte afin d'obtenir la même nuance avec un changement de ton de manière reproductible, selon le nombre de paquets d'une seule dose (16) utilisés.
- 45 20. Procédé selon la revendication 18, **caractérisé en ce qu'il** est proposé d'utiliser deux, ou plusieurs, paquets d'une seule dose (16), chacun contenant un colorant en pâte différent, afin d'obtenir de manière constante et reproductible une nouvelle nuance dérivée de la combinaison desdits deux ou plusieurs colorants.
- 50 21. Procédé selon l'une quelconque des revendications 18 à 20, **caractérisé en ce que** chacun desdits paquets d'une seule dose (16) est pris manuellement par l'utilisateur sur un panneau (11) auquel ils sont associés.
- 55 22. Procédé selon l'une quelconque des revendications 18 à 20, **caractérisé en ce que** chacun desdits paquets d'une seule dose (16) est délivré automatiquement par un distributeur (120) dans lequel sont disposés lesdits paquets d'une seule dose (16).
23. Dispositif de coloration de peintures et de revêtements décoratifs, dans lequel il comprend une pluralité de paquets d'une seule dose (16), chacun contenant une quantité prédéterminée d'un seul colorant en pâte, **caractérisé en ce qu'il** comprend un conteneur (14) à l'intérieur duquel une pluralité de pots (18) contenant une quantité déterminée

EP 1 830 946 B1

de la peinture de base ou du revêtement décoratif sont positionnés, et au moins un panneau (11, 111) portant les nuances des colorants contenus dans lesdits paquets d'une seule dose (16) et les nuances qui peuvent être obtenues, selon un agencement prédéterminé, à partir des combinaisons desdits paquets d'une seule dose (16), et au moins un conteneur (14) dans lequel lesdits pots (18) comprenant la ou les dite(s) quantité(s) unitaire(s) de ladite peinture de base ou dudit revêtement décoratif sont positionnés, dans lequel ledit panneau (11, 111) comprend une pluralité d'espaces colorés (19) ou de cartes de couleur qui portent la représentation graphique de la nuance qui peut être obtenue à partir de la combinaison d'un ou de plusieurs paquet(s) d'une seule dose (16).

- 5
- 10
- 15
- 20
- 25
- 30
- 35
- 40
- 45
- 50
- 55
24. Dispositif selon la revendication 23, **caractérisé en ce qu'il** comprend également un distributeur (120) capable de distribuer automatiquement lesdits paquets d'une seule dose (16) afin d'obtenir une nuance désirée.
 25. Dispositif selon la revendication 24, **caractérisé en ce que** ledit distributeur (120) est capable de délivrer un ou plusieurs paquets d'une seule dose (16) pré-emballé(s).
 26. Dispositif selon la revendication 25, **caractérisé en ce que** ledit distributeur (120) est capable de délivrer un paquet d'une seule dose (16), préparé et scellé dans l'instant à partir des colorants en pâte, en appliquant ou en imprimant sur ce même paquet d'une seule dose les références relatives à la nuance (contenu, code barre, prix, etc.).
 27. Dispositif selon l'une quelconque des revendications 23 à 25, **caractérisé en ce que** ledit distributeur (120) comprend un moyen de commande et d'affichage (121, 122) capable de permettre à l'utilisateur de sélectionner et d'afficher ladite nuance désirée.
 28. Dispositif selon l'une quelconque des revendications 23 à 25, **caractérisé en ce qu'il** comprend un moyen permettant de distribuer ou d'afficher une carte de couleur portant les nuances des colorants contenus dans lesdits paquets d'une seule dose (16) et les nuances pouvant être obtenues, selon un agencement prédéterminé, à partir des combinaisons desdits paquets d'une seule dose (16).
 29. Dispositif selon la revendication 23, **caractérisé en ce que** lesdits paquets d'une seule dose (16) sont disposés sur ledit panneau (11) dans des positions adjacentes aux nuances correspondant au colorant contenu dans ceux-ci.
 30. Dispositif selon la revendication 23, **caractérisé en ce que** lesdits paquets d'une seule dose (16) sont disposés sous le panneau (11, 111) et stockés dans des conteneurs.

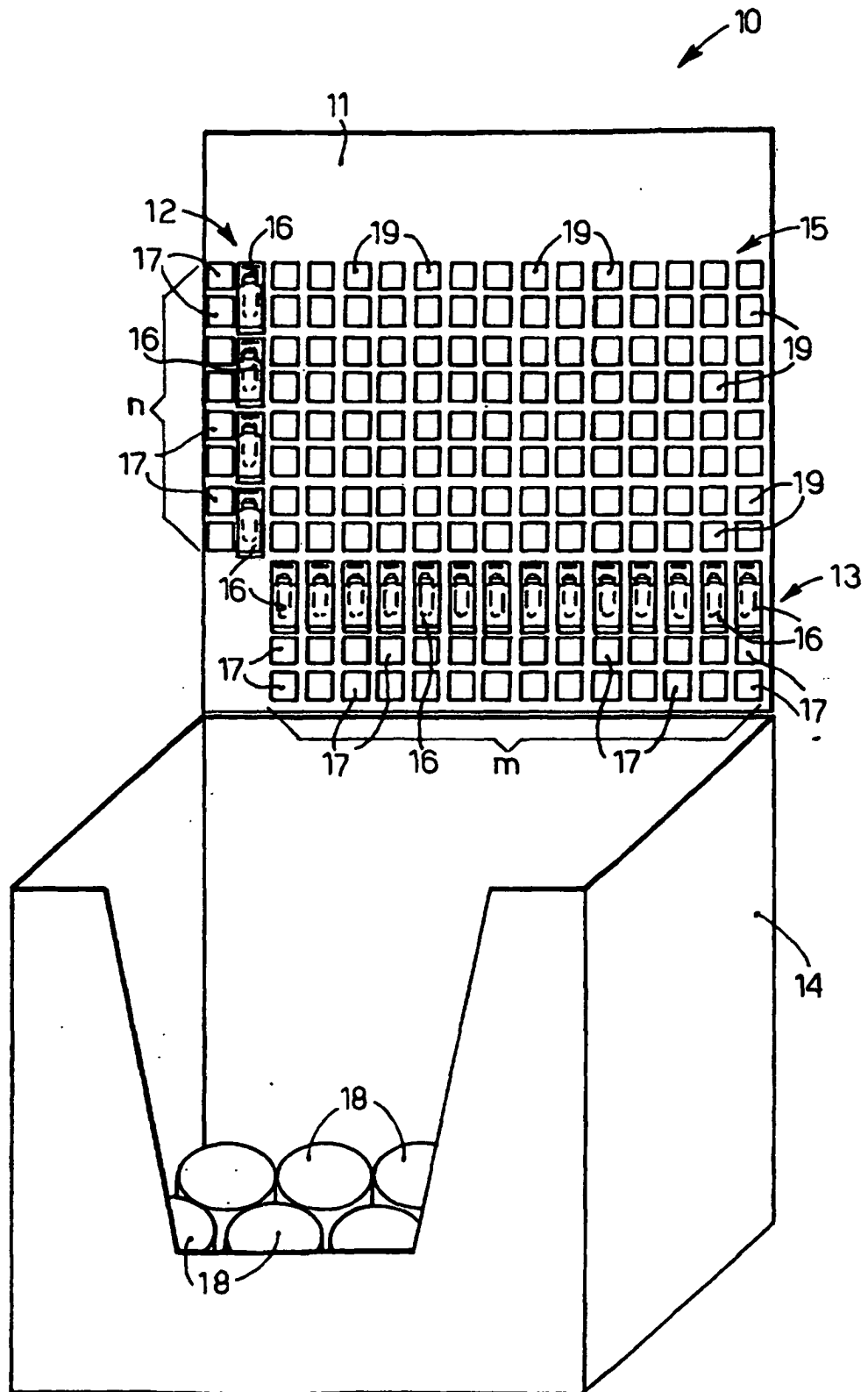

fig. 1

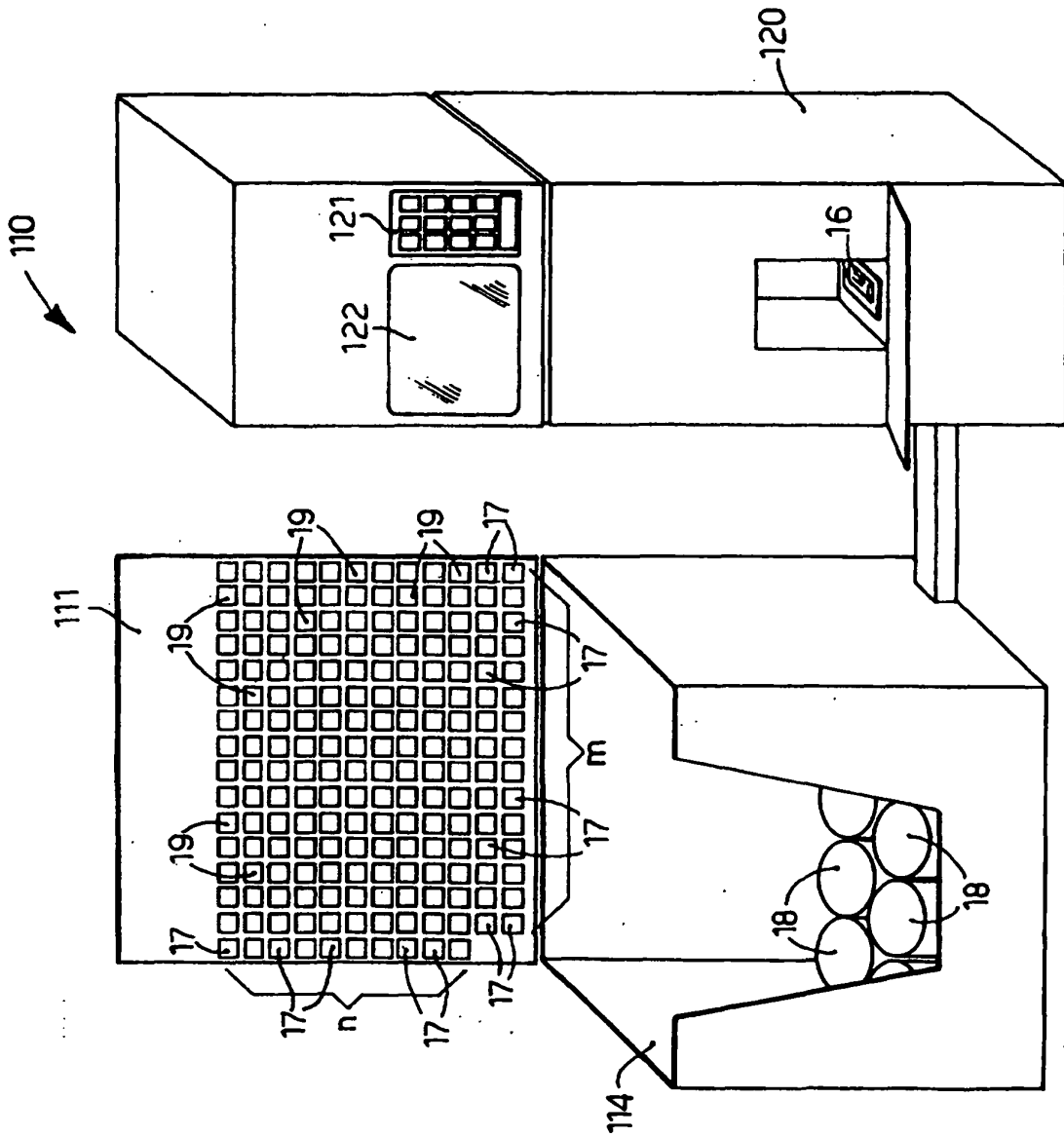

fig. 2

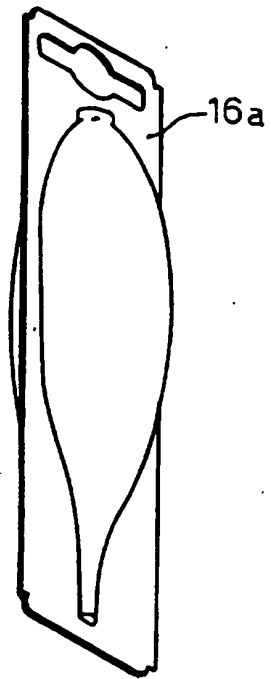

fig. 3

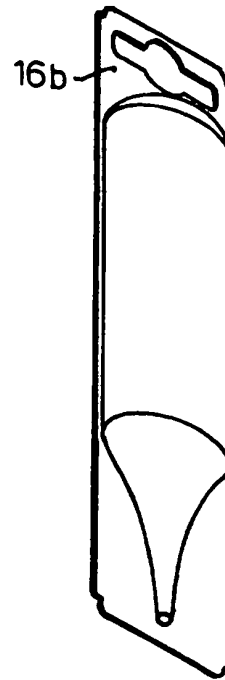

fig. 4

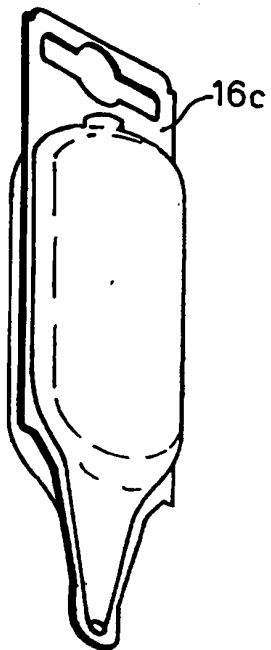

fig. 5

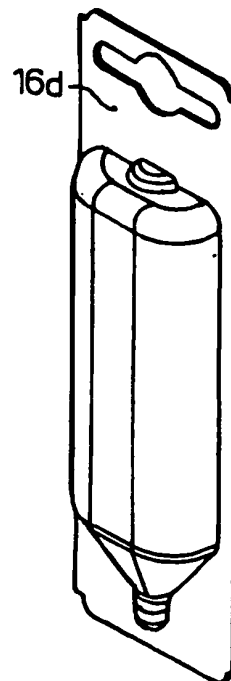
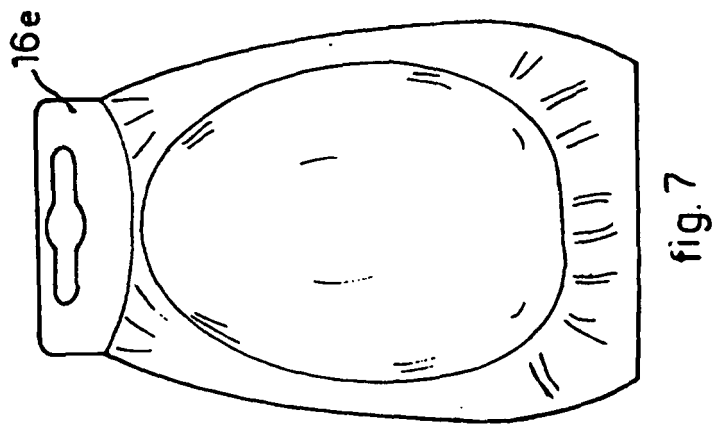
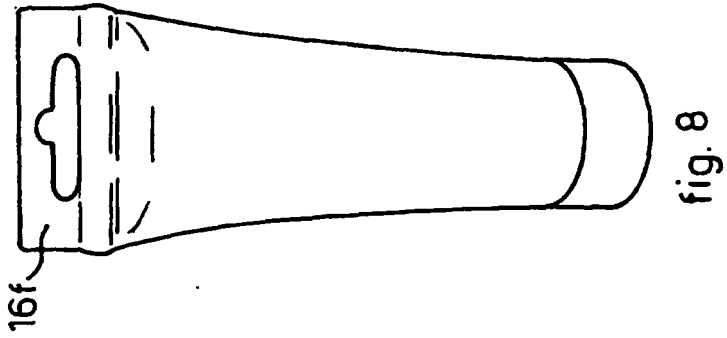
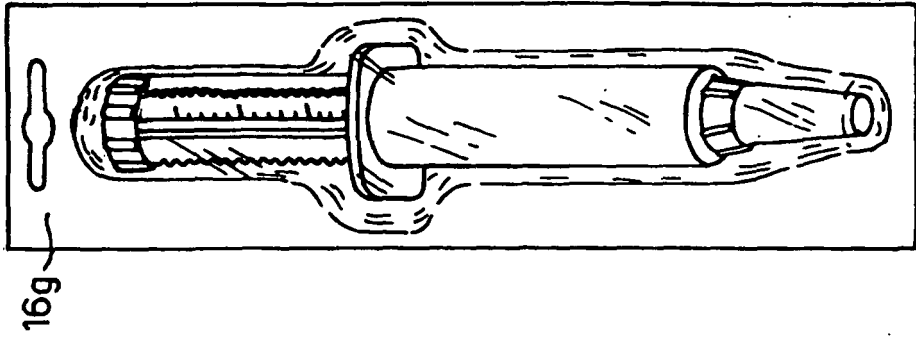

fig. 6



REFERENCES CITED IN THE DESCRIPTION

This list of references cited by the applicant is for the reader's convenience only. It does not form part of the European patent document. Even though great care has been taken in compiling the references, errors or omissions cannot be excluded and the EPO disclaims all liability in this regard.

Patent documents cited in the description

- US 2663461 A [0014]
- FR 1081825 A [0015]