

(12) **United States Patent**
Fulton et al.

(10) **Patent No.:** **US 11,910,524 B2**
(45) **Date of Patent:** ***Feb. 20, 2024**

(54) **BACKLIT USER INTERFACE**
(71) Applicant: **Molex, LLC**, Lisle, IL (US)
(72) Inventors: **Steven Fulton**, Lisle, IL (US);
Matthew Shannon, Lisle, IL (US)
(73) Assignee: **Molex, LLC**, Lisle, IL (US)
(*) Notice: Subject to any disclaimer, the term of this patent is extended or adjusted under 35 U.S.C. 154(b) by 0 days.
This patent is subject to a terminal disclaimer.

(56) **References Cited**
U.S. PATENT DOCUMENTS
7,071,433 B2 7/2006 Holscher
2005/0103611 A1 5/2005 Holscher
(Continued)
FOREIGN PATENT DOCUMENTS
CN 102835030 A 12/2012
CN 105814528 A 7/2016
WO 2019113567 A1 6/2019
OTHER PUBLICATIONS
International Preliminary Report on Patentability received for PCT application No. PCT/US2018/064662, dated Jun. 18, 2020, 05 Pages.
(Continued)
Primary Examiner — Peter D McLoone

(21) Appl. No.: **18/085,611**
(22) Filed: **Dec. 21, 2022**
(65) **Prior Publication Data**
US 2023/0120952 A1 Apr. 20, 2023

Related U.S. Application Data
(63) Continuation of application No. 16/769,243, filed as application No. PCT/US2018/064662 on Dec. 10, 2018, now Pat. No. 11,589,456.
(Continued)

(51) **Int. Cl.**
H05K 1/02 (2006.01)
G06F 3/044 (2006.01)
(Continued)

(52) **U.S. Cl.**
CPC **H05K 1/0274** (2013.01); **G06F 3/044** (2013.01); **H03K 17/962** (2013.01);
(Continued)

(58) **Field of Classification Search**
CPC .. H05K 1/0274; H05K 1/0281; H05K 1/0326; H05K 1/0393; H05K 1/09;
(Continued)

(57) **ABSTRACT**
A number of user interface devices are described. In one example, a user interface device includes a lens having a graphic visible through the lens, a transparent circuit film comprising a top surface and a bottom surface, a reflector film bonded to the bottom surface of the transparent circuit film, the reflector film including an embossed area which defines a pocket between the reflector film and the bottom surface of the transparent circuit film, a light emitting diode (LED) bonded to the bottom surface of the transparent circuit film and positioned within the pocket between the reflector film and the bottom surface of the transparent circuit film, and a layer of transparent pressure-sensitive adhesive interposed between the bottom surface of the lens and the top surface of the transparent circuit film.

20 Claims, 2 Drawing Sheets

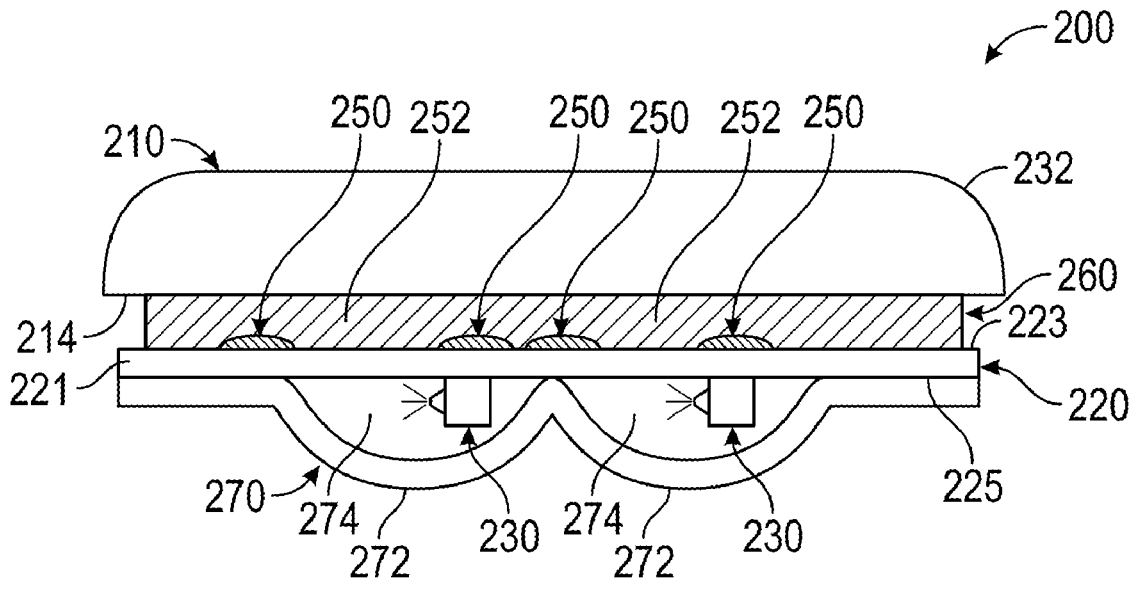

Related U.S. Application Data

(56)

References Cited

(60) Provisional application No. 62/596,522, filed on Dec. 8, 2017.

(51) **Int. Cl.**
H03K 17/96 (2006.01)
H05K 1/03 (2006.01)
H05K 1/09 (2006.01)

(52) **U.S. Cl.**
 CPC *H05K 1/0281* (2013.01); *H05K 1/0326* (2013.01); *H05K 1/0393* (2013.01); *H05K 1/09* (2013.01); *G06F 2203/04103* (2013.01); *H03K 2217/960755* (2013.01); *H05K 2201/0145* (2013.01); *H05K 2201/10106* (2013.01); *H05K 2201/10121* (2013.01)

(58) **Field of Classification Search**
 CPC . H05K 2201/0145; H05K 2201/10106; H05K 2201/10121; G06F 3/044; H03K 17/962; H03K 2217/960755

See application file for complete search history.

U.S. PATENT DOCUMENTS

2006/0268567	A1	11/2006	Jang et al.	
2007/0209916	A1	9/2007	Clegg et al.	
2009/0162617	A1	6/2009	Kojima et al.	
2010/0110327	A1*	5/2010	Kim	G02F 1/133608 445/24
2011/0012845	A1	1/2011	Rothkopf et al.	
2013/0194759	A1	8/2013	Kang et al.	
2013/0248344	A1	9/2013	Stilwell	
2014/0313169	A1	10/2014	Kravets et al.	
2015/0062490	A1	3/2015	Kwon	
2016/0103365	A1	4/2016	Sato	
2017/0294278	A1	10/2017	Chen et al.	
2021/0020393	A1*	1/2021	Liang	H01H 13/14

OTHER PUBLICATIONS

International Search Report and Written Opinion received for PCT application No. PCT/US2018/064662, dated Apr. 5, 2019, 07 Pages.

* cited by examiner

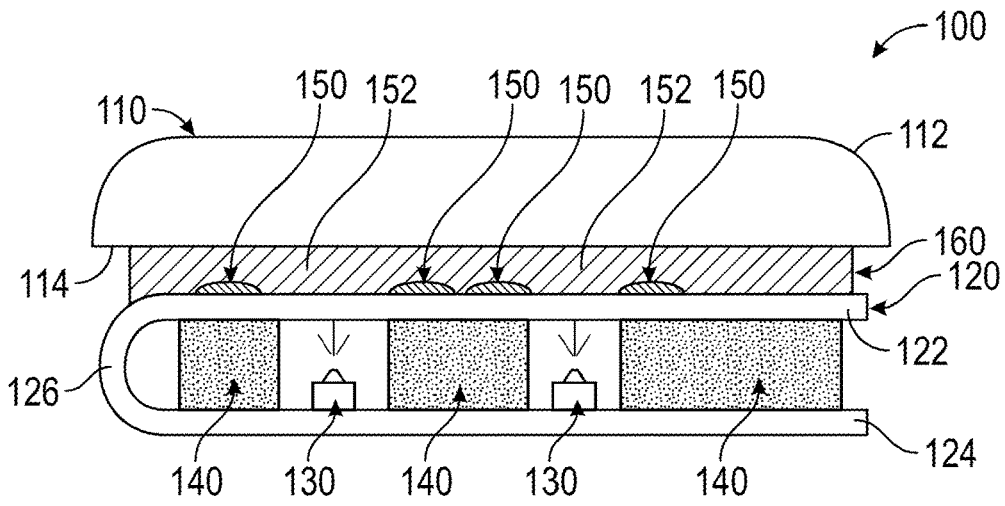

FIG. 1

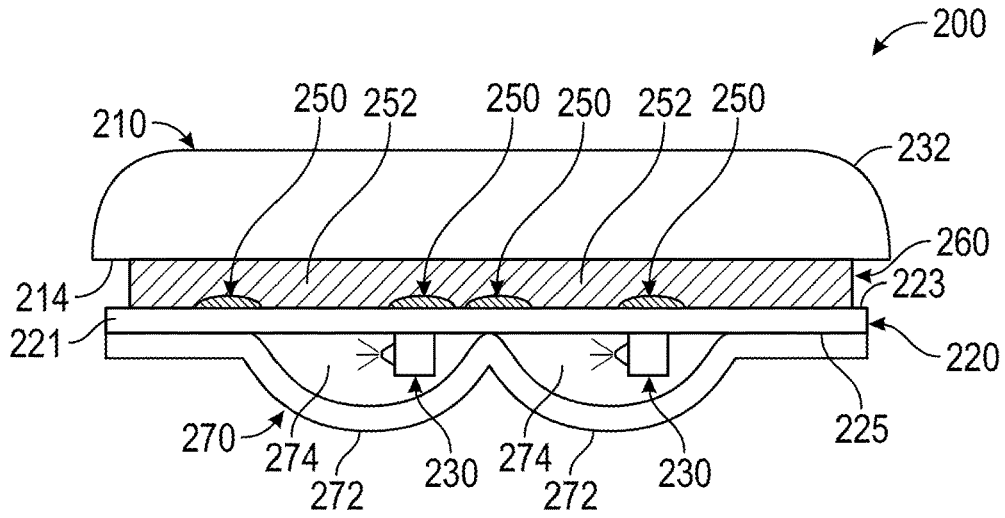

FIG. 2

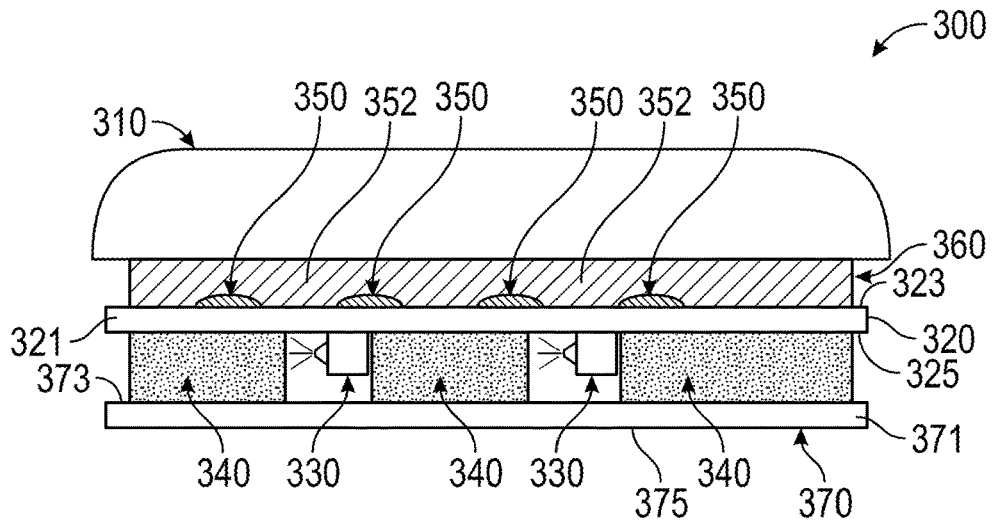

FIG. 3

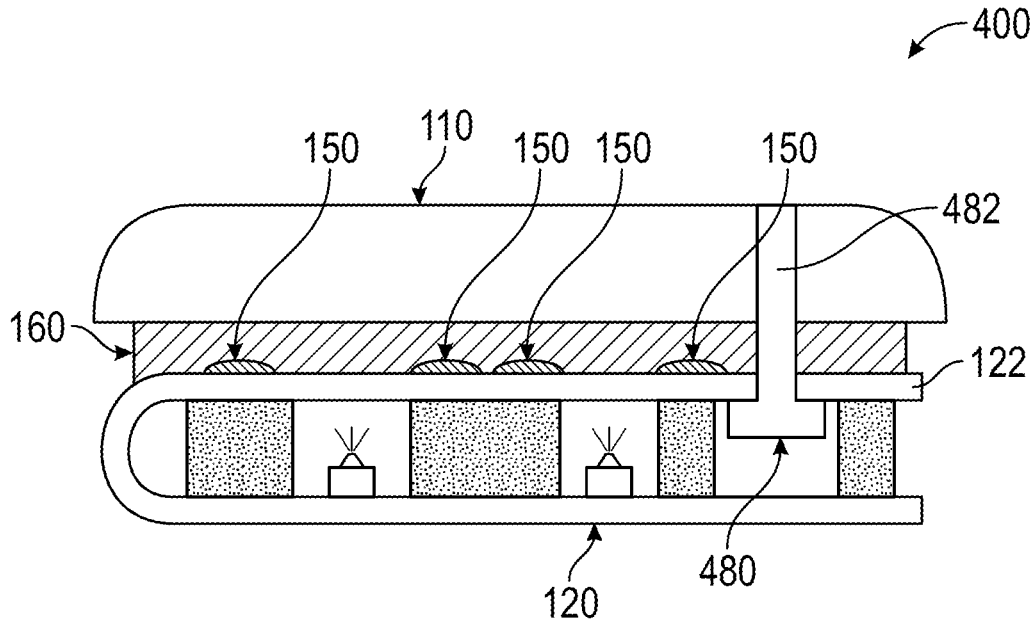

FIG. 4

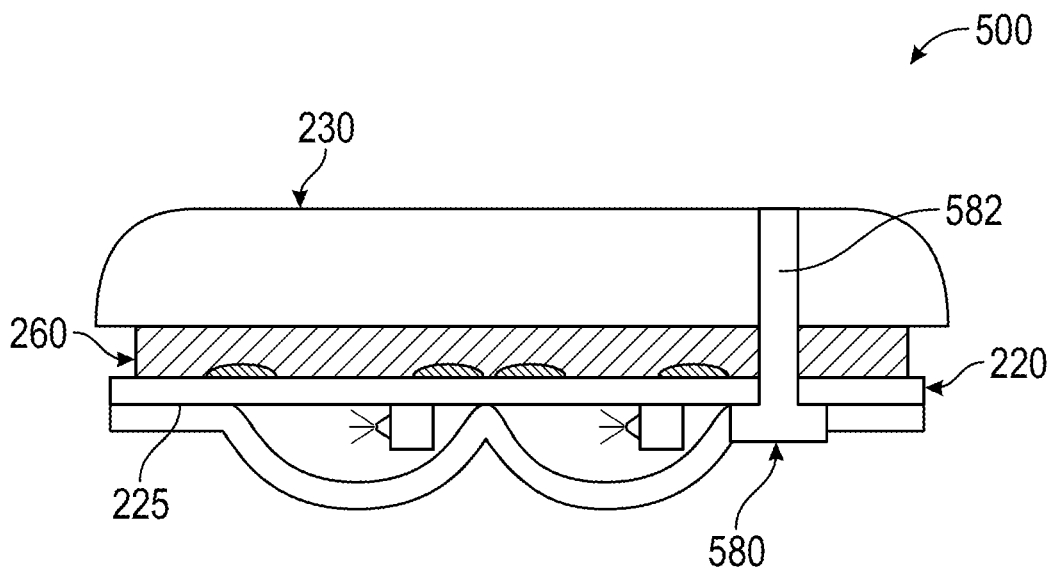

FIG. 5

1

BACKLIT USER INTERFACECROSS-REFERENCE TO RELATED
APPLICATIONS

This application is a continuation of U.S. Non-Provisional patent application Ser. No. 16/769,243, filed Jun. 3, 2020, titled "BACKLIT USER INTERFACE," which is the U.S. national stage application of International Patent Application No. PCT/US2018/064662, filed Dec. 10, 2018, which claims the benefit of priority under 35 U.S.C. § 119(e) of U.S. Provisional Patent Application No. 62/596,522, filed Dec. 8, 2017, the entire contents of each of which applications are hereby incorporated herein by reference.

FIELD OF THE INVENTION

The present disclosure relates to user interfaces for use on various devices, including virtual personal assistants, home appliances and medical devices.

DESCRIPTION OF RELATED ART

User interfaces for use on various devices are known. These user interfaces typically use capacitive touch sensing technology. Such user interfaces, however, traditionally require higher cost substrates like printed circuit boards (PCBs) or flexible printed circuits (FPC). These PCBs and FPCs then also require the use of molded light pipes and light guides as the PCBs and FPCs do not allow light to transfer from one side thereof to the other side thereof. Furthermore, flexible light guide films provide poor quality of backlighting and PCBs cannot accommodate curved surfaces or be in-molded. As a result, certain individuals would appreciate further improvements to user interfaces.

SUMMARY

A user interface device includes a lens with a top surface and a bottom surface, where the bottom surface includes at least one graphic that is visible through the top surface of the lens. The user interface device further includes a transparent circuit film with a top surface and a bottom surface, at least one light emitting diode (LED), at least one silver conductor, and a layer of transparent pressure-sensitive adhesive that secures the bottom surface of the lens to the top surface of the transparent circuit film.

In a first aspect, the transparent circuit film is in a fold-over configuration such that the transparent circuit film has a top layer and a bottom layer that are connected by a connecting end portion, where the top layer and the bottom layer are separated a desired distance from one another to allow for the at least one LED and at least one spacer to be positioned therebetween.

In a second aspect, user interface device further includes a reflector film.

BRIEF DESCRIPTION OF THE DRAWINGS

The present disclosure is illustrated by way of example, and not limited, in the accompanying figures, which are not drawn to scale, in which like reference numerals indicate similar elements and in which:

FIG. 1 illustrates features of a first embodiment of a backlit user interface;

FIG. 2 illustrates features of a second embodiment of a backlit user interface;

2

FIG. 3 illustrates features of a third embodiment of a backlit user interface;

FIG. 4 illustrates features of a fourth embodiment of a backlit user interface; and

FIG. 5 illustrates features of a fifth embodiment of a backlit user interface.

DETAILED DESCRIPTION

FIGS. 1-5 illustrate exemplary embodiments of the present disclosure and it is to be understood that the disclosed embodiments are merely exemplary of the disclosure, which may be embodied in various forms. Therefore, specific details disclosed herein are not to be interpreted as limiting, but merely as a basis for the claims and as a representative basis for teaching one skilled in the art to variously employ the present disclosure. It is further to be understood that the illustrations are not drawn to scale.

FIG. 1 illustrates a first embodiment of a backlit user interface **100**. The backlit user interface **100** includes a lens **110**, a transparent circuit film **120**, at least one light emitting diode (LED) **130**, at least one spacer **140**, at least one silver conductor **150**, and a layer of transparent pressure-sensitive adhesive **160**.

The lens **110** is preferably formed of plastic material which is generally transparent. The lens **110** has a top surface **112** and a bottom surface **114**. The top surface **112** is preferably curved and is intended to be contacted by a user. The bottom surface **114** is preferably flat and is intended to have at least one graphic (not illustrated) provided thereon such that the graphic is visible by viewing through the top surface **112** of the lens **110**. The graphic may be applied to the bottom surface **114** of the lens **110** in any suitable manner, e.g., spray paint, laser etch, screen-print or digital print.

The transparent circuit film **120** is preferably formed of polyester (PET). The transparent circuit film **120** is preferably provided in a fold-over configuration such that the transparent circuit film **120** is provided with a top layer **122** and a bottom layer **124** that are connected by a connecting end portion **126**. The top layer **122** and the bottom layer **124** are separated a desired distance from one another to allow for the at least one LED **130** and the at least one spacer **140** to be positioned therebetween. The transparent circuit film **120** may be electrically connected to another portion of the device on which the backlit user interface **100** is provided, e.g., by a header connector attached to the circuit with low-temp solder, facing down away from the lens, by a tail that is compatible with a ZIF connector or by contact pads provided on the bottom layer **124**, possibly with carbon coating, that are intended for pogo-pins.

The at least one LED **130** is bonded to the bottom layer **124** of the transparent circuit film **120** in a top-fire position, preferably using a low temperature solder material, such that the at least one LED **130** emits light toward and through the top layer **122** of the transparent circuit film **120**.

The at least one spacer **140** is preferably formed of foam. The at least one spacer **140** is preferably bonded in place between the top and bottom layer **122**, **124** of the transparent circuit film **120**. The at least one spacer **140** is positioned around the at least one LED **130** and, if more than one LED **130** is provided, the at least one spacer **140** is positioned to separate one LED **130** from another LED **130**.

The at least one silver conductor **150** is preferably screen printed on the top layer **122** of the transparent circuit film **120** to provide at least one capacitive touch sensor. The at least one silver conductor **150** is preferably opaque. The

number of silver conductors **150** provided will typically match the number of LEDs **130** provided. Each silver conductor **150** is generally formed in a ring-like configuration such that a space **152** is defined within a middle of the ring-like configuration. In this context, ring-like is intended to mean completely closed (e.g., in an O-shape) or partially closed (e.g., in a C-shape or a U-shape). Each silver conductor **150** is positioned generally above (as viewed in FIG. 1) one of the LEDs **130** such that the space **152** defined is in general vertical alignment (as viewed in FIG. 1) with the LED **130**.

The lens **110** and the transparent circuit film **120** are preferably secured to one another by the layer of transparent pressure-sensitive adhesive **160** and positioned between the bottom surface **114** of the lens **110** and either the top layer **122** of the transparent circuit film **120** or the at least one silver conductor **150**. Thus, the layer of transparent pressure-sensitive adhesive **160** occupies the space **152** defined by the at least one silver conductor **150**.

In operation, the light emitted by the at least one LED **130** will pass through the transparent circuit film **120**, through the layer of transparent pressure-sensitive adhesive **160** (including the portion thereof that occupies space **152**), and onto the graphic (as the graphic is also positioned in general vertical alignment (as viewed in FIG. 1) with the space **152**), thereby providing backlighting for the user interface **100** which allows the user to easily view the graphic.

FIG. 2 illustrates a second embodiment of a backlit user interface **200**. The backlit user interface **200** includes a lens **210**, a transparent circuit film **220**, at least one light emitting diode (LED) **230**, a reflector film **270**, at least one silver conductor **250**, and a layer of transparent pressure-sensitive adhesive **260**.

The lens **210** is preferably formed of plastic material which is generally transparent. The lens **210** has a top surface **212** and a bottom surface **214**. The top surface **212** is preferably curved and is intended to be contacted by a user. The bottom surface **214** is preferably flat and is intended to have at least one graphic (not illustrated) provided thereon such that the graphic is visible by viewing through the top surface **212** of the lens **210**. The graphic may be applied to the bottom surface **214** of the lens **210** in any suitable manner, e.g., spray paint, laser etch, screen-print or digital print.

The transparent circuit film **220** is preferably formed of polyester (PET). The transparent circuit film **220** is preferably provided in a single layer **221** having a top surface **223** and a bottom surface **225**. The transparent circuit film **220** may be electrically connected to another portion of the device on which the backlit user interface **200** is provided, e.g., by a header connector attached to the circuit with low-temp solder, facing down away from the lens, by a tail that is compatible with a ZIF connector or by contact pads provided on the bottom surface **225**, possibly with carbon coating, that are intended for pogo-pins.

The at least one LED **230** is bonded to the bottom surface **225** of the transparent circuit film **220** in a right angle-fire position, preferably using a low temperature solder material, such that the at least one LED **230** emits light generally parallel to the transparent circuit film **220**.

The reflector film **270** is preferably formed of a white reflector material. The reflector film **270** is preferably bonded in place to the bottom surface **225** of the transparent circuit film **220**. The reflector film **270** is configured to provide at least one embossed area **272** which defines a pocket **274** between the reflector film **270** and the bottom surface **225** of the transparent circuit film **220**. The number

of pockets **274** defined corresponds to the number of LEDs **230** provided as each LED **230** is positioned in a corresponding pocket **274**.

The at least one silver conductor **250** is preferably screen printed on the top surface **223** of the transparent circuit film **220** to provide at least one capacitive touch sensor. The at least one silver conductor **150** is preferably opaque. The number of silver conductors **250** provided will typically match the number of LEDs **230** provided. Each silver conductor **250** is generally formed in a ring-like configuration such that a space **252** is defined within a middle of the ring-like configuration. In this context, ring-like is intended to mean completely closed (e.g., in an O-shape) or partially closed (e.g., in a C-shape or a U-shape). Each silver conductor **250** is positioned generally above (as viewed in FIG. 2) one of the pockets **274** such that the space **252** defined is in general offset from being in vertical alignment (as viewed in FIG. 2) with the LED **230**.

The lens **210** and the transparent circuit film **220** are preferably secured to one another by the layer of transparent pressure-sensitive adhesive **260** and positioned between the bottom surface **214** of the lens **210** and either the top surface **223** of the transparent circuit film **220** or the at least one silver conductor **250**. Thus, the layer of transparent pressure-sensitive adhesive **260** occupies the space **252** defined by the at least one silver conductor **250**.

In operation, light emitted by the at least one LED **230** will pass through the transparent circuit film **220** (either directly or after bouncing off of the reflector film **270**), through the layer of transparent pressure-sensitive adhesive **260** (including the portion thereof that occupies space **252**), and onto the graphic (as the graphic is also positioned in general vertical alignment (as viewed in FIG. 2) with the space **252**), thereby providing backlighting for the user interface **200** which allows the user to easily view the graphic.

FIG. 3 illustrates a third embodiment of a backlit user interface **300**. The backlit user interface **300** includes a lens **310**, a transparent circuit film **320**, at least one light emitting diode (LED) **330**, a reflector film **370**, at least one spacer **340**, at least one silver conductor **350**, and a layer of transparent pressure-sensitive adhesive **360**.

The lens **310** is preferably formed of plastic material which is generally transparent. The lens **310** has a top surface **312** and a bottom surface **314**. The top surface **312** is preferably curved and is intended to be contacted by a user. The bottom surface **314** is preferably flat and is intended to have at least one graphic (not illustrated) provided thereon such that the graphic is visible by viewing through the top surface **312** of the lens **310**. The graphic may be applied to the bottom surface **314** of the lens **310** in any suitable manner, e.g., spray paint, laser etch, screen-print or digital print.

The transparent circuit film **320** is preferably formed of polyester (PET). The transparent circuit film **320** is preferably provided in a single layer **321** having a top surface **323** and a bottom surface **325**. The transparent circuit film **320** may be electrically connected to another portion of the device on which the backlit user interface **300** is provided, e.g., by a header connector attached to the circuit with low-temp solder, facing down away from the lens, by a tail that is compatible with a ZIF connector or by contact pads provided on the bottom surface **325**, possibly with carbon coating, that are intended for pogo-pins.

The reflector film **370** is preferably formed of a white reflector material. The reflector film **370** is preferably provided in a single layer **371** having a top surface **373** and a bottom surface **375**.

The at least one LED **330** is bonded to the bottom surface **325** of the transparent circuit film **320** in a right angle-fire position, preferably using a low temperature solder material, such that the at least one LED **330** emits light generally parallel to the transparent circuit film **320**.

The at least one spacer **340** is preferably formed of foam. The at least one spacer **340** is preferably bonded in place between the bottom surface **325** of the transparent circuit film **320** and the top surface **373** of the reflector film **370**. The at least one spacer **340** is positioned around the at least one LED **330** and, if more than one LED **330** is provided, the at least one spacer **340** is positioned to separate one LED **330** from another LED **330**.

The at least one silver conductor **350** is preferably screen printed on the top surface **323** of the transparent circuit film **320** to provide at least one capacitive touch sensor. The at least one silver conductor **350** is preferably opaque. The number of silver conductors **350** provided will typically match the number of LEDs **330** provided. Each silver conductor **350** is generally formed in a ring-like configuration such that a space **352** is defined within a middle of the ring-like configuration. In this context, ring-like is intended to mean completely closed (e.g., in an O-shape) or partially closed (e.g., in a C-shape or a U-shape). Each silver conductor **350** is positioned generally above (as viewed in FIG. 3) one of the LEDs **330** such that the space **352** defined is in general vertical alignment (as viewed in FIG. 3) with the LED **330**.

The lens **310** and the transparent circuit film **320** are preferably secured to one another by the layer of transparent pressure-sensitive adhesive **360**, which is positioned between the bottom surface **314** of the lens **310** and either the top surface **323** of the transparent circuit film **320** or the at least one silver conductor **350**. Thus, the layer of transparent pressure-sensitive adhesive occupies the space **352** defined by the at least one silver conductor **350**.

In operation, light emitted by the at least one LED **330** will pass through the transparent circuit film **320** (either directly or after bouncing off of the reflector film **370**), through the layer of transparent pressure-sensitive adhesive **360** (including the portion thereof that occupies space **352**), and onto the graphic (as the graphic is also positioned in general vertical alignment (as viewed in FIG. 3) with the space **352**), thereby providing backlighting for the user interface **300** which allows the user to easily view the graphic.

FIG. 4 illustrates a fourth embodiment of a backlit user interface **400**. The backlit user interface **400** is identical to the first embodiment of the backlit user interface **100** (see FIG. 1), except that backlit user interface **400** also includes a microphone **480** as a part thereof, where the lens **110**, the layer of pressure-sensitive adhesive **160** and the top layer **122** of the transparent circuit film **120** have an aperture **482** therethrough for the microphone **480**. The microphone **480** is preferably bonded to the top layer **122** of the transparent circuit film **120**, on the opposite side of the top layer **122** as compared to the at least one silver conductor **150**.

FIG. 5 illustrates a fifth embodiment of a backlit user interface **500**. The backlit user interface **500** is identical to the second embodiment of the backlit user interface **200** (see FIG. 2), except that the backlit user interface **500** also includes a microphone **580** as a part thereof, where the lens **210**, the layer of pressure-sensitive adhesive **260** and the

transparent circuit film **220** have an aperture **582** therethrough for the microphone **580**. The microphone **580** is preferably bonded to the bottom surface **225** of the transparent circuit film **220**.

It will be understood that there are numerous modifications of the illustrated embodiments described above which will be readily apparent to one skilled in the art, including combinations of features disclosed herein that are individually disclosed or claimed herein, explicitly including additional combinations of such features, or alternatively other types of embodiments of the same. Also, there are many possible variations in the materials and configurations, including, but not limited to, as examples: (a) the embodiments could be provided with a graphic film could be used instead of a lens; (b) the embodiments could be provided with or without LEDs; (c) the embodiments could be provided with or without LED drive circuitry; (d) the embodiments could be provided with or without microphones; (e) the embodiments could be provided with or without capacitive touch chip and firmware; (f) the embodiments could be provided with backlighting of a user interface with LEDs bonded to a low-cost circuit (which provides lower cost as compared to traditional backlit user interfaces); (g) the embodiments could be provided with a substrate that is flexible polyester (which provides the benefits of being lower cost, flexible and transparent); (h) the embodiments could utilize reflective material behind the LEDs to direct the light to the user (which provides better lighting quality); (i) the embodiments could have graphic overlays on top surfaces to create backlit icons; (j) the embodiments could have combined graphical and electrical circuit on one substrate material (which provides lower costs); (k) the embodiments could have graphic/circuit in-molded into a lens/bezel (which allows for use of a curved surface and better appearance); (l) the embodiments could have capacitive touch for sensing user input; (m) the embodiments could have capacitive sensors with ring geometry, allowing backlighting through the transparent center of the ring (which allows for backlighting for keys and better quality than light guide film); (n) the embodiments could have a transparent center of the touch sensor with either no conductor or a transparent conductor (which provides improved backlighting and improved capacitive sensing through thick materials); (o) the embodiments could have LEDs bonded to the circuit with low-temp solder (which provides that there is no substrate damage during SMT); (p) the embodiments could have microprocessor-based circuitry included on the polyester circuit (which provides lower cost); (q) the embodiments could have silver circuit traces applied to the substrate with screen printing (which provides lower cost); (r) the embodiments could have LEDs located a distance away from the capacitive sensor to improve capacitive sensitivity (which allows touch sensing through thicker materials); (s) the embodiments could have LEDs which are top-fire, right-angle fire, or reverse-fire (which provides different options for quality lighting); (t) the embodiments could have transparent, conductive ink provided in the opening defined by the silver conductor, such that the silver conductor does not need to surround the opening as much as it needs to if the transparent, conductive ink is not used.

At least the following is claimed:

1. A user interface device, comprising:
 - a lens comprising a graphic visible through the lens;
 - a transparent circuit film comprising a top surface and a bottom surface;
 - a reflector film bonded to the bottom surface of the transparent circuit film, the reflector film comprising an

- embossed area which defines a pocket between the reflector film and the bottom surface of the transparent circuit film;
 - a light emitting diode (LED) bonded to the bottom surface of the transparent circuit film and positioned within the pocket between the reflector film and the bottom surface of the transparent circuit film; and
 - a layer of transparent pressure-sensitive adhesive interposed between the bottom surface of the lens and the top surface of the transparent circuit film to secure the bottom surface of the lens to the top surface of the transparent circuit film.
2. The user interface device of claim 1, wherein a top surface of the lens is curved.
 3. The user interface device of claim 1, wherein the graphic is applied to a bottom surface of the lens by at least one of spray paint, laser etch, screen-print, or digital print.
 4. The user interface device of claim 3, wherein the bottom surface of the lens is flat.
 5. The user interface device of claim 1, wherein the transparent circuit film is formed of polyester (PET).
 6. The user interface device of claim 1, wherein the LED is bonded to the bottom surface of the transparent circuit film in a right angle-fire position.
 7. The user interface device of claim 1, further comprising a microphone bonded to the bottom surface of the transparent circuit film.
 8. The user interface device of claim 7, wherein the lens and the transparent circuit film each comprise an aperture therethrough for the microphone.
 9. The user interface device of claim 1, further comprising a silver conductor on the top surface of the transparent circuit film.
 10. The user interface device of claim 9, wherein:
 - the silver conductor is formed in a ring on the top surface of the transparent circuit film to provide at least one capacitive touch sensor; and
 - the ring of the silver conductor is aligned with the embossed area which defines the pocket.
 11. The user interface device of claim 1, wherein:
 - the reflector film comprises a plurality of embossed areas which define a plurality of pockets between the reflector film and the bottom surface of the transparent circuit film; and

- the LED comprises a plurality of LEDs, at least one LED among the plurality of LEDs being positioned within a respective pocket among the plurality of pockets.
12. A user interface device, comprising:
 - a lens;
 - a top film layer and a bottom film layer under the lens, the bottom film layer comprising an embossed area which defines a pocket between the bottom film layer and a bottom surface of the top film layer; and
 - a light emitting diode (LED) positioned within the pocket between the top film layer and the bottom film layer.
 13. The user interface device of claim 12, wherein:
 - the top film layer comprises a transparent circuit film; and
 - the LED is bonded to a bottom surface of the transparent circuit film.
 14. The user interface device of claim 13, wherein the LED is bonded to the bottom surface of the transparent circuit film in a right angle-fire position.
 15. The user interface device of claim 12, further comprising a microphone bonded to the top film layer.
 16. The user interface device of claim 15, wherein the lens comprises an aperture therethrough for the microphone.
 17. The user interface device of claim 12, further comprising a silver conductor on a top surface of the top film layer.
 18. The user interface device of claim 17, wherein:
 - the silver conductor is formed in a ring on the top surface of the top film layer to provide at least one capacitive touch sensor; and
 - the ring of the silver conductor is aligned with the embossed area which defines the pocket.
 19. The user interface device of claim 12, wherein:
 - the top film layer comprises a transparent circuit film;
 - the LED is bonded to a bottom surface of the transparent circuit film; and
 - the bottom film layer comprises a reflector film.
 20. The user interface device of claim 12, wherein:
 - the bottom film layer comprises a plurality of embossed areas which define a plurality of pockets between the bottom film layer and the bottom surface of the top film layer; and
 - the LED comprises a plurality of LEDs, at least one LED among the plurality of LEDs being positioned within a respective pocket among the plurality of pockets.

* * * * *