

(No Model.)

7 Sheets—Sheet 1.

J. R. ROWLANDS. GAME APPARATUS.

No. 523,712.

Patented July 31, 1894.

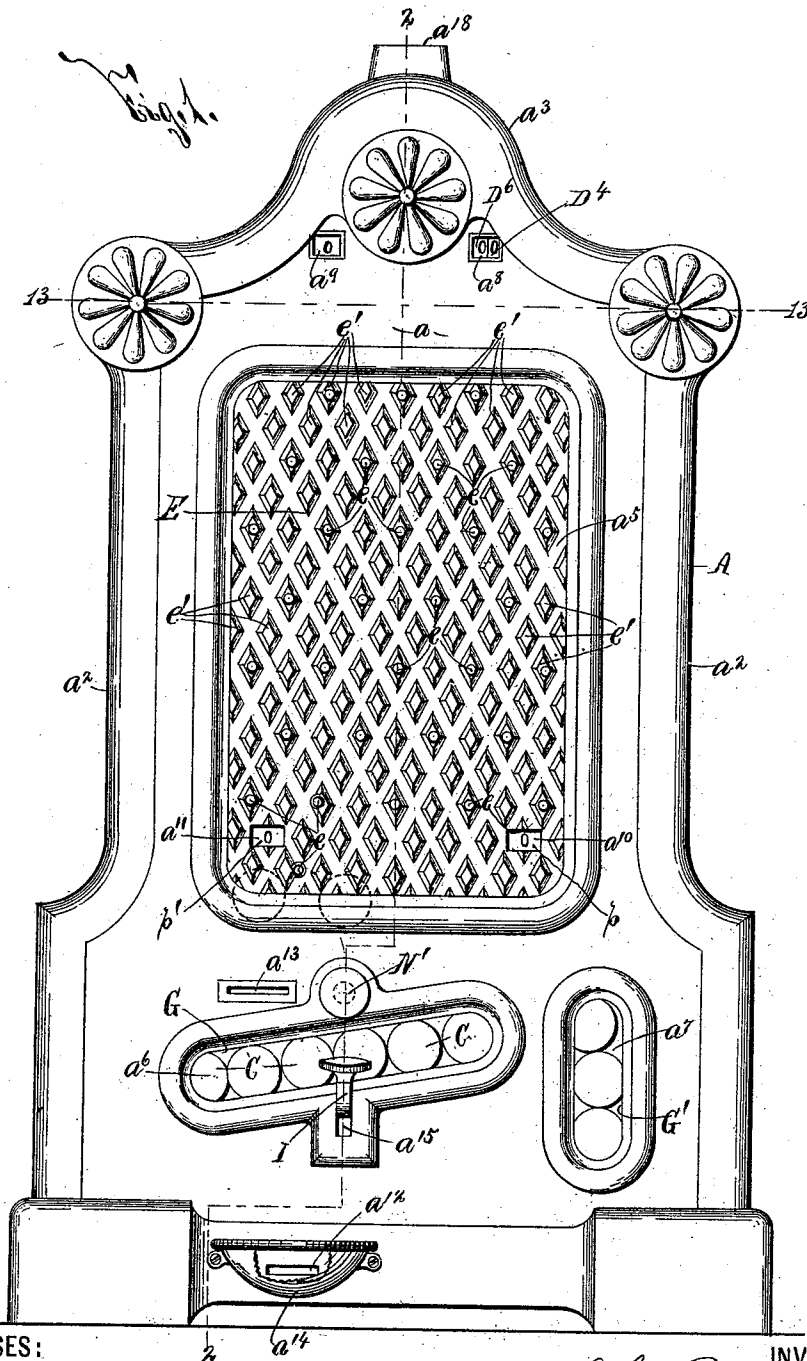

WITNESSES:

H. Chase
C. Schoenack

INVENTOR

John R. Rowlands

BY

Wm. Wilkinson & Parsons
ATTORNEYS.

(No Model.)

7 Sheets—Sheet 2.

J. R. ROWLANDS. GAME APPARATUS.

No. 523,712.

Patented July 31, 1894.

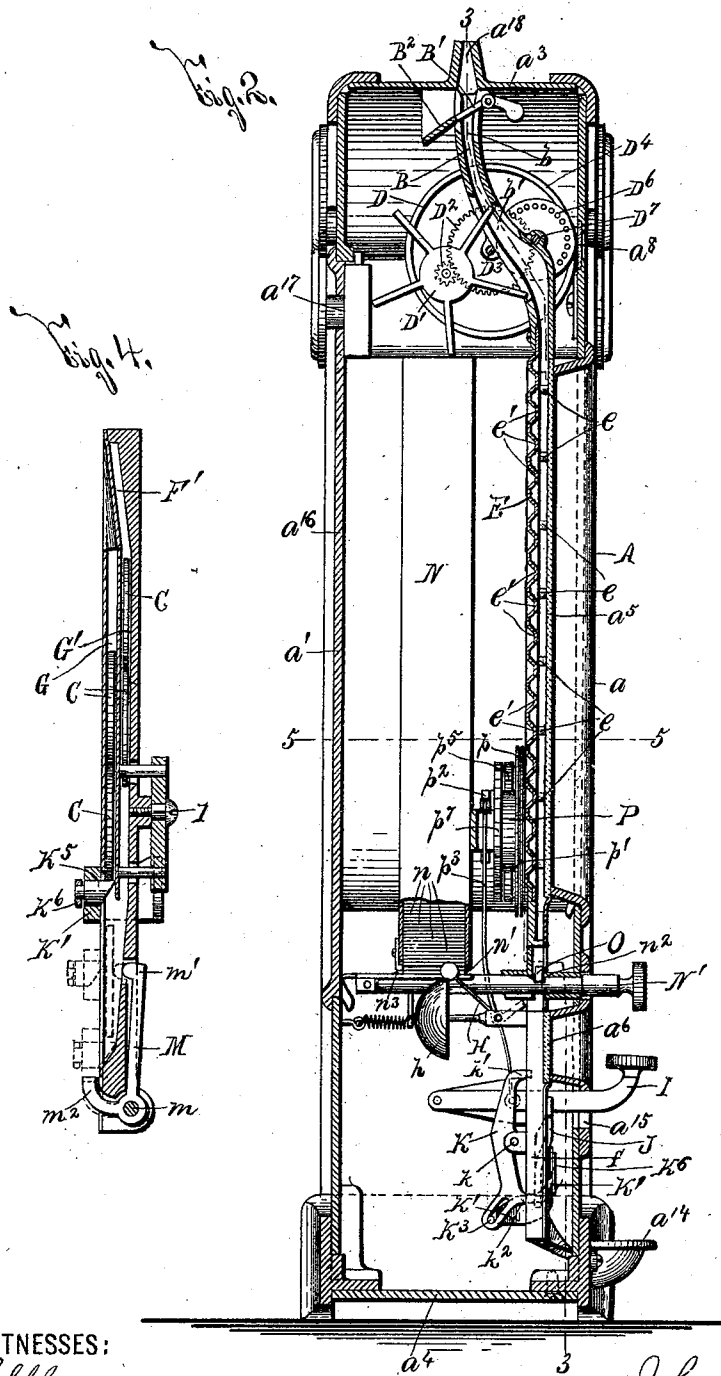

WITNESSES:

C. Chase,
C. Schoenck,

INVENTOR.

John R. Rowlands

BY

Wm. H. Kilmer & Parsons
ATTORNEYS,

(No Model.)

7 Sheets—Sheet 3.

J. R. ROWLANDS. GAME APPARATUS.

No. 523,712.

Patented July 31, 1894.

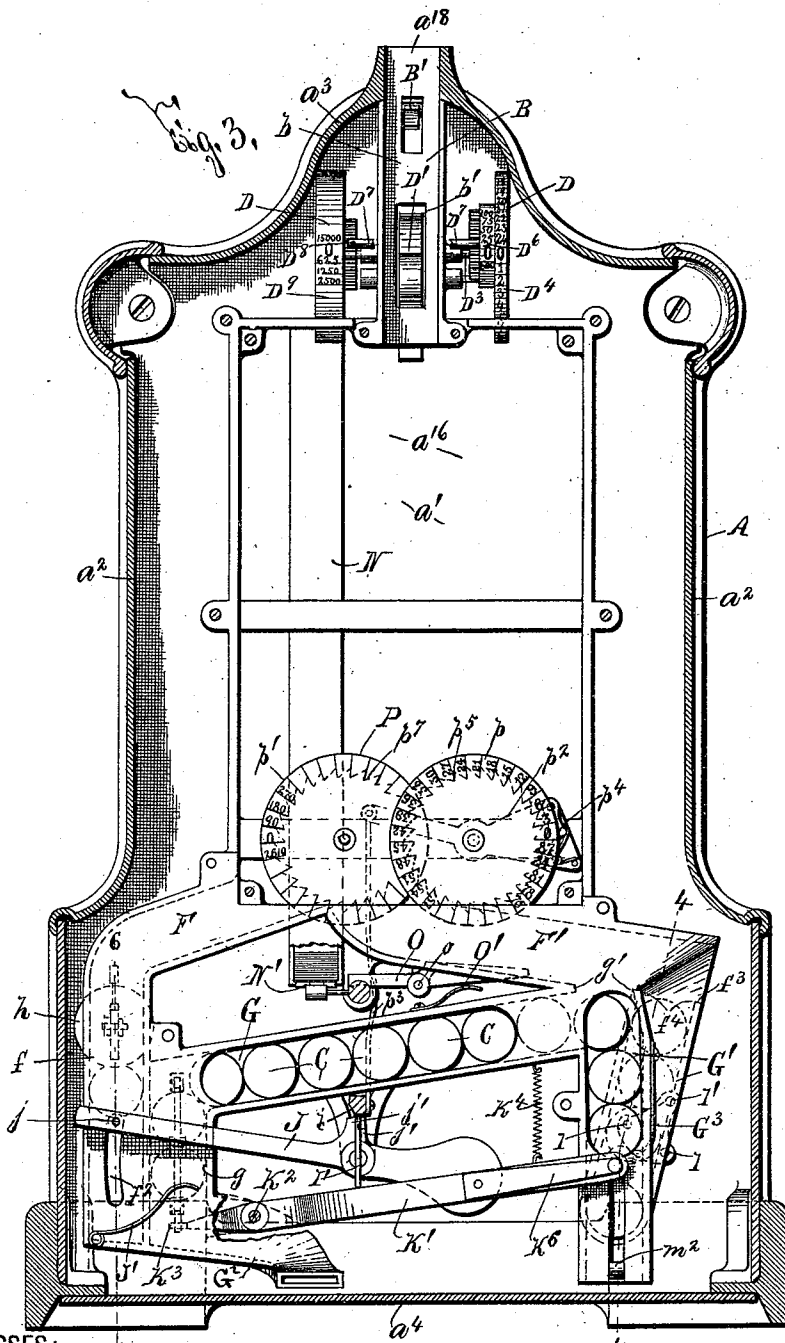

WITNESSES:

6
H. C. Chase
E. Schoenck

INVENTOR

4
John R. Rowlands

BY

Key Wilkinson & Parsons
 ATTORNEYS,

(No Model.)

7 Sheets—Sheet 4.

J. R. ROWLANDS.
GAME APPARATUS.

No. 523,712.

Patented July 31, 1894.

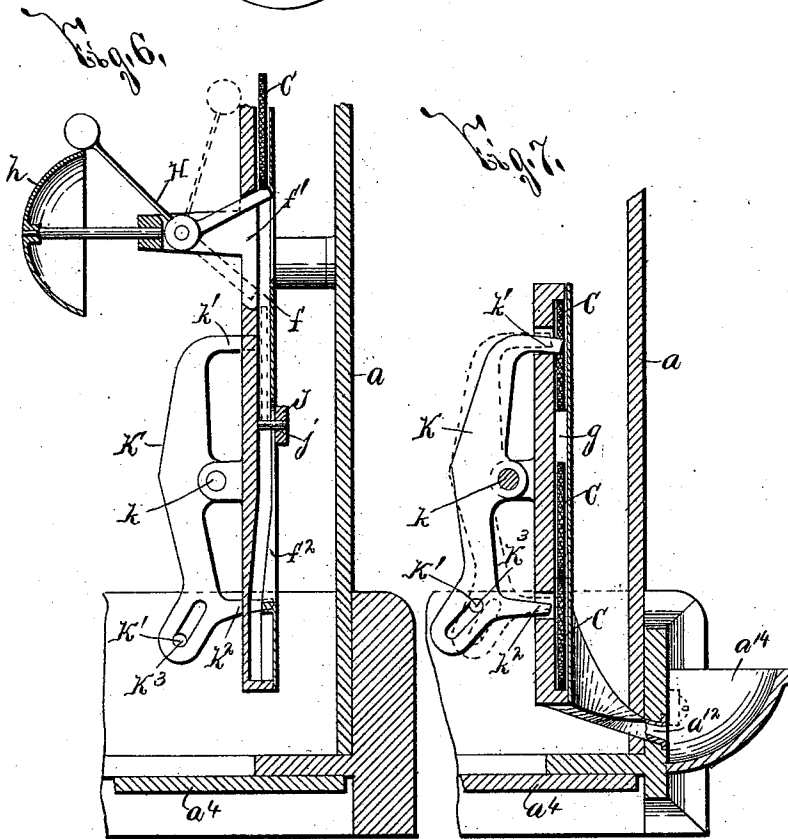
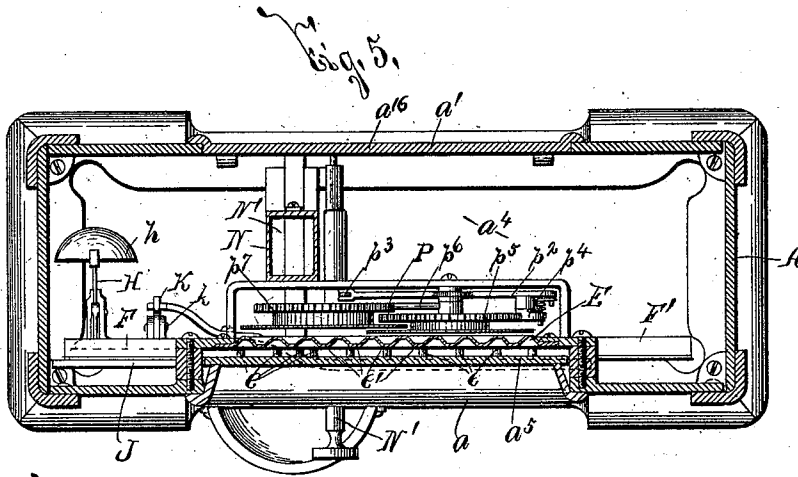

WITNESSES:

H. C. Chase,
E. Schoenck,

INVENTOR

John R. Rowlands

BY

Hey, Wilkinson & Parsons,

ATTORNEYS,

(No Model.)

7 Sheets—Sheet 5.

J. R. ROWLANDS.
GAME APPARATUS.

No. 523,712.

Patented July 31, 1894.

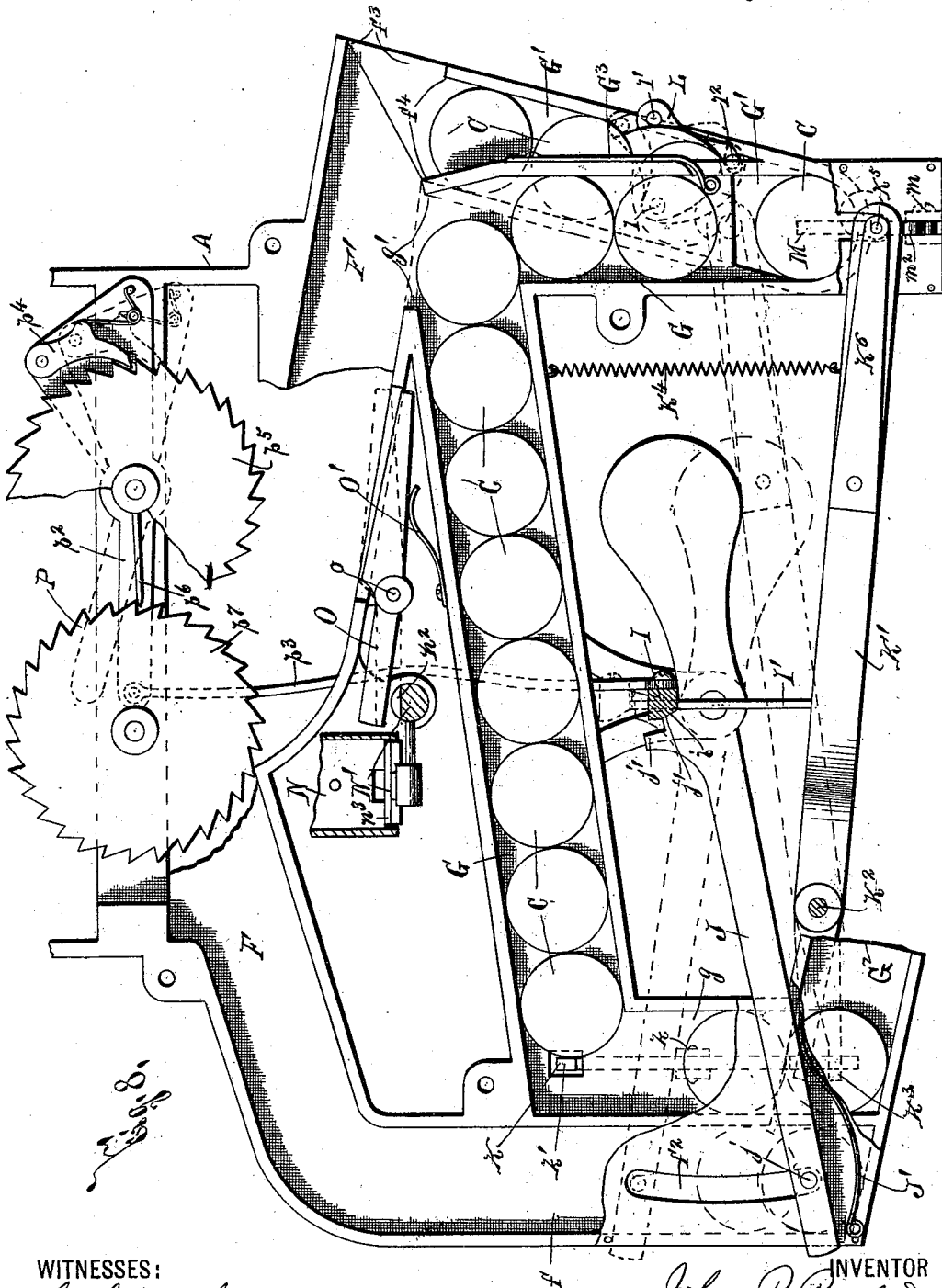

WITNESSES:

C. Schoeneck,
M. D. Lewis,

INVENTOR

John R. Rowlands,

BY

Hey, Wilkinson & Parsons
ATTORNEYS,

(No Model.)

7 Sheets—Sheet 6.

J. R. ROWLANDS.
GAME APPARATUS.

No. 523,712.

Patented July 31, 1894.

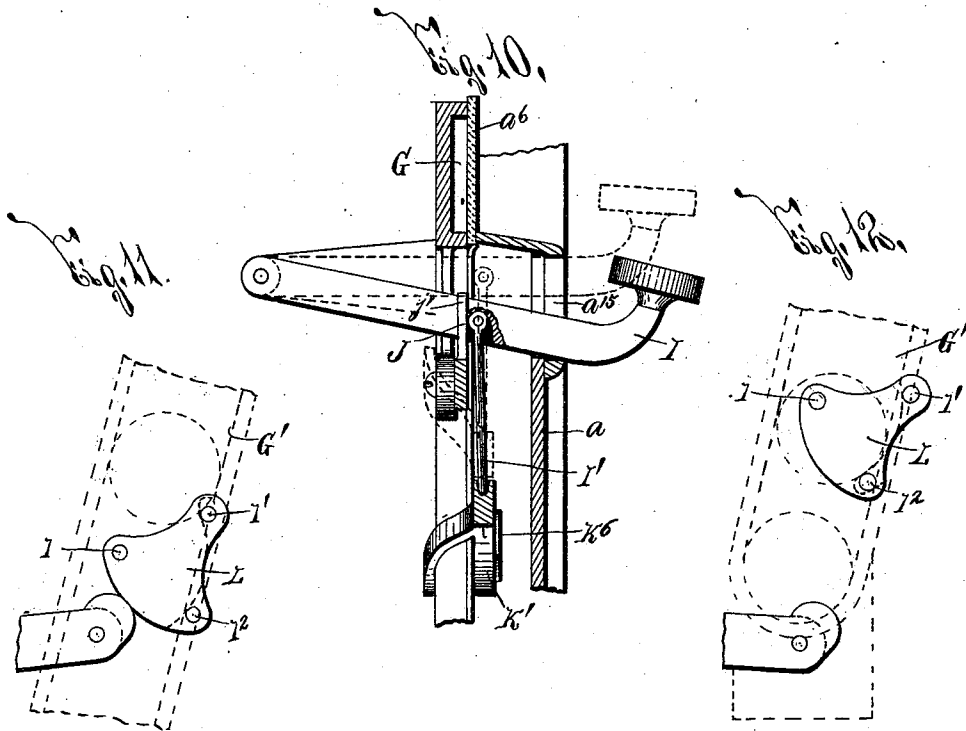
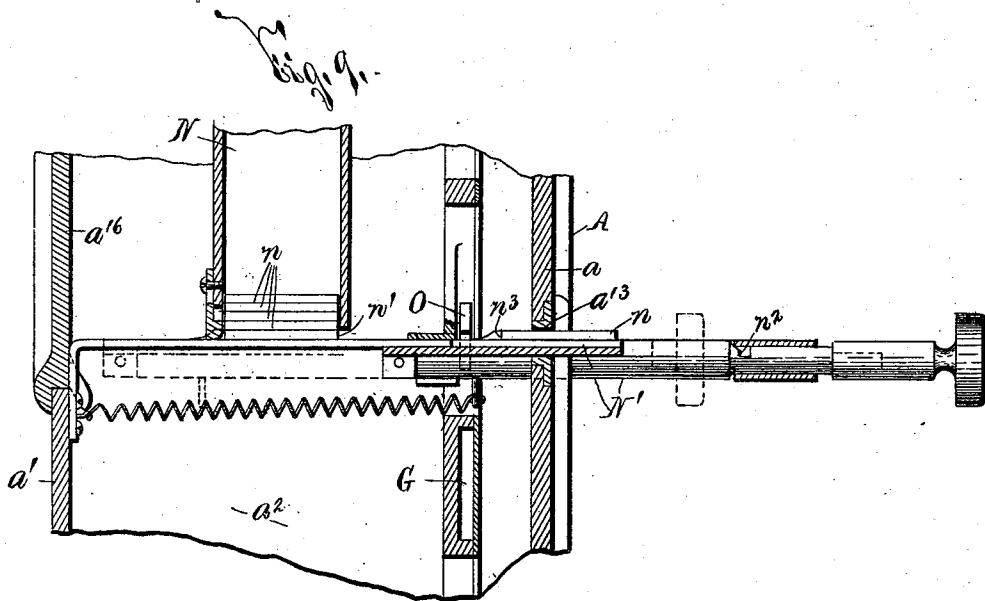

WITNESSES:
C. Schweick,
M. D. Lewis.

INVENTOR
John R. Rowlands
 BY
Hayden & Parsons,
 ATTORNEYS

J. R. ROWLANDS.
GAME APPARATUS.

No. 523,712.

Patented July 31, 1894.

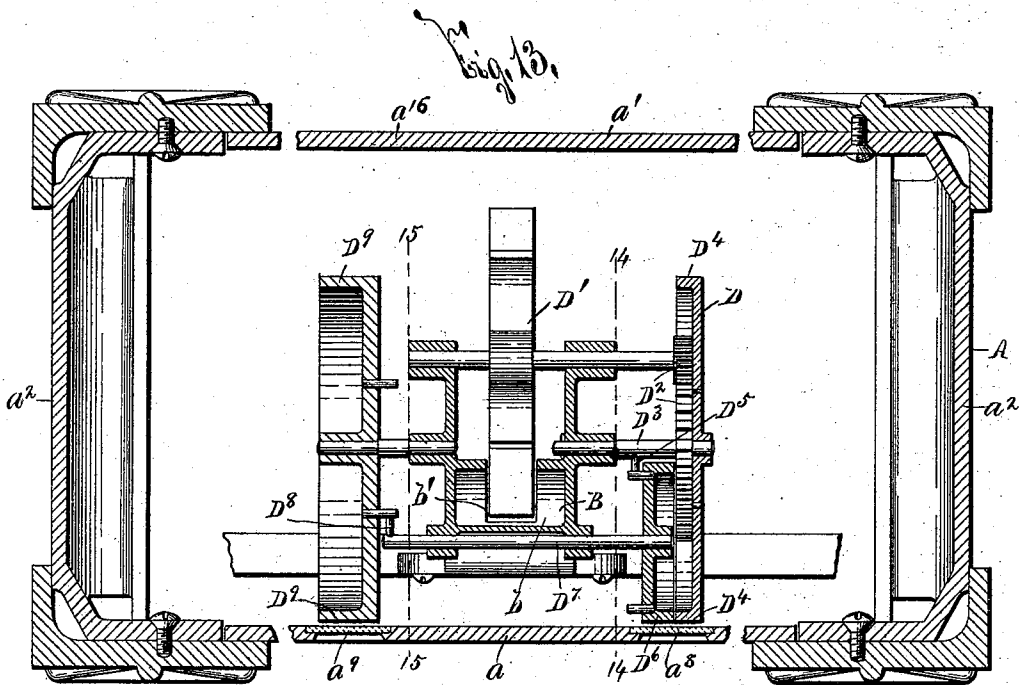

Fig. 14.

Fig. 15.

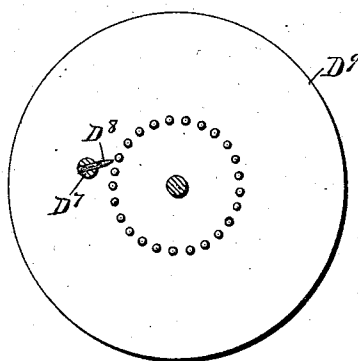
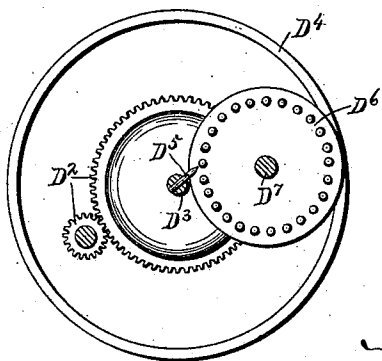
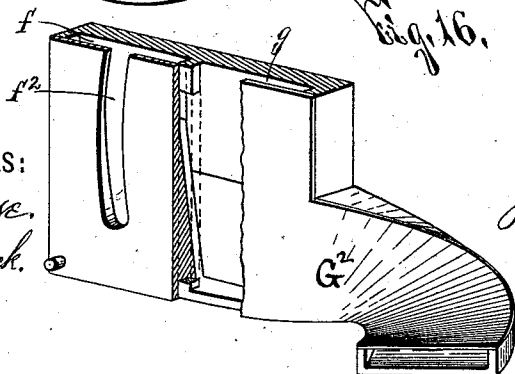

Fig. 16.



WITNESSES:

H. C. Chase.
E. Schoenack.

INVENTOR

John R. Rowlands

BY

Wm. Wilkinson & Parsons
ATTORNEYS.

UNITED STATES PATENT OFFICE.

R. ROWLANDS, OF SYRACUSE, NEW YORK, ASSIGNOR OF TWO-THIRDS
O WARREN H. BOLES AND WALTON H. WALES, OF SAME PLACE.

GAME APPARATUS.

SPECIFICATION forming part of Letters Patent No. 523,712, dated July 31, 1894.

Application filed July 19, 1893. Serial No. 480,883. (No model.)

To all whom it may concern:

Be it known that I, JOHN R. ROWLANDS, of Syracuse, in the county of Onondaga, in the State of New York, have invented new and
5 useful Improvements in Game Apparatus, of which the following, taken in connection with the accompanying drawings, is a full, clear, and exact description.

My invention relates to improvements in
10 game apparatus, and has for its object the production of a simple and attractive amusement, which is economically manufactured, is durable in use, effective in operation, and permits of the ready computation of the actuating members fed within the game, and
15 those discharged therefrom for reuse; and to this end it consists, essentially, in a chute for the actuating members, a movable part for making contact with the members passed
20 through the chute, counting mechanism controlled by said movable part, a support having a series of pins thereon for forming ways or guides for the actuating members, and diverging ways or guides for receiving said actuating members passed through the ways or
25 guides of said support.

The invention furthermore consists in a support provided with said pins or projections and having a series of raised surfaces thereon
30 for making contact with the actuating members and reducing to a minimum the liability of adhesion thereof to said supports, a discharge extremity for one of said diverging ways, an alarm operated by the actuating
35 members passed through said discharge end, a feeding way or guide having downturned extremities, one being provided with a discharge opening in proximity to said discharge extremity, and a second or auxiliary feeding
40 way or guide for conveying the actuating members to the former feeding way or guide.

The invention still furthermore consists in a receptacle for the counting members of the game, a feed for feeding said members from
45 said receptacle, a lock for said feed having a movable part projecting into one of said diverging ways or guides, a regulator for controlling the passage through the discharge opening of the feeding way or guide, a lever
50 for operating said regulator, a counter con-

nected to said lever, and in the detail construction and arrangement of the parts, all as hereinafter more particularly described and pointed out in the claims.

In describing this invention, reference is
55 had to the accompanying drawings, forming a part of this specification, in which like letters indicate corresponding parts in all the views.

Figure 1 is an elevation of my improved
60 invention illustrating its general construction and arrangement. Figs. 2 and 3 are vertical sectional views, taken respectively on lines 2—2, Fig. 1, and 3—3, Fig. 2. Fig. 4 is a detail sectional view, taken on line 4—4,
65 Fig. 3. Fig. 5 is a horizontal sectional view, taken on line 5—5, Fig. 2. Figs. 6 and 7 are detail sectional views, taken on lines 6—6, Fig. 3; Fig. 6 illustrating the alarm for the discharge end of one of the diverging ways
70 or guides and the regulator for the discharge end of the feeding way or guide, and Fig. 7 showing the regulator illustrated at Fig. 6 as in its position assumed when permitting
75 discharge of two of the actuating members. Fig. 8 is an enlarged elevation of the diverging ways or guides, the main and auxiliary feeding ways or guides, the lower end of the receptacle for the counting members of the
80 game apparatus, the feed for discharging said members, the lock for preventing the action of said feed, the regulator for controlling the discharge of the actuating members from the feeding way or guide, the lever for
85 operating said regulator, the lock for said lever, and the connection between said lever and the feeding way or guide for forcing the actuating members therethrough. Fig. 9 is a detail sectional view of the lower end of the receptacle for the counting members and
90 the feed for discharging the members from said receptacle, said feed being illustrated in its operative position. Fig. 10 is a detail sectional view illustrating the lever for discharging the actuating members from the
95 discharge end of the feeding way or guide. Figs. 11 and 12 are detail views illustrating the regulator for the second or auxiliary feeding way or guide. Fig. 13 is a horizontal sectional view, taken on line 13—13, Fig. 1, 100

illustrating the counting mechanism for indicating the number of actuating members passed within my improved game apparatus. Figs. 14 and 15 are detail views of said counting mechanism, taken on lines 14—14 and 15—15, Fig. 13, and Fig. 16 is a detail view, partly in section, of the discharge ends of one of the diverging ways or guides and the feeding way or guide.

10 The inclosing case A is of any desirable form, size, and construction, and preferably consists of front, rear, opposite side, and top and bottom walls a' , a^2 , a^3 , a^4 . The front wall is formed with transparent panels a^5 a^6 15 a^7 for indicating the passage of the actuating members and with apertures a^8 a^9 for indicating the operation of the counting mechanism which registers the number of actuating members passed within my game 20 apparatus. The transparent panel a^5 is provided at its lower end with apertures a^{10} a^{11} for registering with the index wheel of the counting mechanism that registers the number of actuating members passed through 25 the game apparatus to enable their reuse, and the front wall a is provided with outlet openings a^{12} a^{13} for the discharge of the actuating and counting members of the game apparatus, a shallow cup or receptacle a^{14} for the re- 30 ception of the discharged actuating members, and a slot a^{15} for a lever presently described, that controls the action of the regulator for the discharge of the actuating members, and the mechanism for counting said discharged 35 members.

The back wall a' is provided with a removable door a^{16} having a lock a^{17} of any suitable construction for securing said removable door in operative position.

40 The top wall a^3 is formed with an inlet opening a^{18} , and registered with said inlet opening and arranged within the outer case of my game apparatus is a chute B for the actuating members C, which are here illus- 45 trated as circular disks.

The chute B is of desirable form and construction, its lower end is preferably nearer the front wall of the outer case than its upper end, its upper end is provided with an 50 opening b therethrough, and its lower end with a similar opening b' .

Movable within the opening b is one end of a hinged gate B' having its other end sufficiently weighted to be elevated only by an 55 actuating member C of the proper weight. If, however, an actuating member of less than the normal weight is inserted within the chute B, the end of the gate B' projecting within said chute is not depressed, but deflects said 60 member of light weight along a lateral projection or guide B².

D' is a movable part of a counting mechanism D projecting into the opening b' in the lower end of the chute B, and, as clearly seen 65 at Fig. 2, this movable part consists of a revolvable wheel having projecting arms movable in said opening b' . As each actuating

member descends it depresses one of the arms of the movable part D' until said arm is forced out of the opening b' , and the next succeeding arm is forced into said opening, and therefore partially rotates said movable part D'. This movable part or wheel is connected by gearing D² to a shaft D³ carrying an indicating wheel D⁴ provided on its outer 75 face with a series of indicating numerals or characters registering with the opening a^8 in the front wall a of the case A. Also provided on the shaft D³ is an arm D⁵, which engages a series of projections upon an indicating wheel D⁶ secured to a shaft D⁷. The indicating wheel D⁶ is arranged alongside of the front portion of the wheel D⁴, and is also 80 provided on its periphery with indicating numerals or characters registering with the openings a^8 . Provided on the shaft D⁷ is an arm D⁸, which engages a series of projections on a disk D⁹ provided on its outer face with a series of indicating numerals or characters registering with the opening a^9 in the wall a 90 of the case A.

The movable part D' and the indicating wheels D⁴ D⁶ D⁹ of the counting mechanism D are so relatively arranged that, as one of the arms of the movable part D' is depressed, 95 the wheel D⁴ is partially revolved to expose through the opening a^8 a number or character indicating the passage of said actuating member, and, as the wheel D⁴ makes a complete revolution, the wheel D⁶ is partially 100 revolved to expose through the opening a^8 the number of actuating members passed into the game apparatus and required to effect a complete revolution of the wheel D⁴. The wheel D⁴ is then revolved a second time, and, when 105 its complete revolution is effected, the wheel D⁶ has been again partially revolved for indicating the number of actuating members required to rotate the wheel D⁴ twice. After the wheel D⁴ has been continuously revolved 110 a sufficient number of times to effect a complete revolution of the wheel D⁶, the arm D⁸ produces a partial revolution of the wheel D⁹, and, after the wheel D⁶ has been continuously revolved a number of times, the wheel D⁹ is 115 revolved once.

This counting mechanism is particularly simple and practical, and serves to positively and effectively count the number of actuating members passed within the game apparatus, thereby relieving the players from such 120 responsibility, and obviating all liability of mistake or fraud. It is evident, however, that a counting mechanism for this purpose may be entirely dispensed with if desired, 125 and that other counting mechanisms may be used, and consequently my invention is not limited to any particular construction of counting mechanism as D.

Directly beneath the chute B, and at the 130 inside of the transparent panel a^5 is a plate E provided with a series of alternately arranged projecting pins e sufficiently separated to permit passage of the actuating mem-

bers C. These pins *e* form a series of ways or guides for the actuating members, which pass downwardly to the base of the plate E.

In order that the liability of adhesion of the actuating members to the plate E may be reduced to a minimum, even when said members are more or less moist, as is sometimes the case, owing to continued handling, the plate E is formed with a series of raised bearing surfaces *e'* and interposed depressions, which reduce to a minimum the amount of surface making contact with the actuating members.

At the base of the plate E are diverging ways or guides F F', and in proximity to the ways F F' is a feeding way or guide G having downturned extremities, one of which is connected by a second or auxiliary feeding way or guide G' to the discharge end of the way F'. The way F is formed with a discharge extremity *f* in proximity to the discharge extremity *g* of the feeding way G, and both of said discharge extremities *f g* feed the actuating members into an inclined chute G², which discharges said members through the opening *a*¹² in the front wall *a* of the case A into the receptacle *a*¹⁴.

The diverging ways or guides F F' are so arranged in connection with the projections *e* of the plate E that the actuating members passed through the guide F' are greatly in excess of the number passed through the opposite guide F, and the guide F is preferably provided with a suitable alarm, Fig. 6, for indicating the passage of an actuating member therethrough. This alarm preferably consists of a pivoted lever H having one extremity adapted to engage a vibrating bell disk *h* and the other projecting into the guide F through an opening *f'* therein. As an actuating member descends through the guide F, it depresses the end of the lever H projecting within said guide, and, as the actuating member passes from engagement with said end of the lever H, the opposite end comes in contact with the disk *h*, and the player is thereby informed of the passage of an actuating member through the guide F.

I is a lever pivoted at its inner end within the case and having its outer end projecting through the opening *a*¹⁵ to the outside of the case A. This lever is connected, as presently described, to actuate the regulator for governing the passage of the actuating members through the feeding way or guide G, and is normally locked from movement by a stop consisting of a counterbalanced lever J having one end weighted and its other end provided with a lug *j* movable in a slot *f*² in the lower feeding end *f* of the way or guide F.

The central portion of the lever J is provided with an upwardly projecting arm having a series of shoulders *j' j'* for engaging the lever I, and the lever I is formed with an inclined face *i* for bearing against the base of the upwardly projecting arm of the lever J and rocking the same.

As an actuating member descends through the discharge extremity of the guide or way F, it engages the projection *j* of the lever J, and depresses the adjacent end of said lever until it contacts with a suitable stop spring J', and said actuating member thereby disengages the shoulders of the central arm thereof from the lever I, and consequently the player is free to depress said lever I. As the lever I is depressed its inclined shoulder *i* bears against the base of the central arm of the lever J, and rocks the outer end of said lever downwardly against the action of the spring J', thereby permitting the escape from the feeding end *f* of the way or guide F, of the actuating member resting upon the projection *j* of the lever J, and serving to depress the same out of operative position, for permitting movement of the lever I. At the same time that the lever I rocks the lever J, so as to permit the escape of the actuating member engaged with said lever the lever I operates the regulator for the discharge end of the feeding way or guide G, and permits the passage to the way or guide G² of two of the actuating members stored within the feeding way or guide G.

The regulator K for the discharge end of the feeding way or guide G consists of a lever pivoted at *k*, and having separated arms *k'* *k*² arranged one above the other, and movable into and out of said way or guide, and sufficiently separated to permit the entrance between said arms of two of the actuating members. As clearly seen at Fig. 2 the lower arm *k*² is normally within the feeding way or guide, and supports the superimposed actuating members.

Connecting the lever I and the regulator K is a lever K' pivoted at K² and having one end provided with a lug K³ movable in an inclined slot in the lower end of the regulator K. The opposite end of the lever K' is detachably engaged by a depending arm I' pivoted at its upper end to the lever I, and is forced downwardly as said lever is depressed. Consequently as the lever I is depressed the upper arm *k'* of the regulator K is forced into the way or guide directly above the two lower actuating members therein and the lower arm *k*² is withdrawn from said way or guide, thereby permitting the discharge from the way or guide G of the two outer actuating members therein. As previously stated this operation of the regulator does not take place until immediately after the lever J has been sufficiently depressed to permit the escape therefrom of the actuating member engaged therewith for depressing said lever J.

As soon as the actuating member resting upon the lug or arm *j* of the lever J passes downwardly from engagement therewith, said lever J being counterbalanced, immediately tends to assume its normal position, and is prevented therefrom only when the player holds the lever I in its depressed position. At the instant, however, that pressure is re-

moved from said lever I, a spring K^4 secured to the lever K' immediately elevates the lever I, and the lower shoulder upon the central upwardly extending arm of the lever J assumes a position directly beneath the lever I before the upward movement of the lever K' has been sufficient to cause the regulator K to assume its normal position with its upper arm out of the way or guide G and its lower arm k^2 projecting into said way or guide. As the lever I continues its upward movement and the regulator K' is caused to assume its upper position the upper shoulder of the central upwardly projecting arm of the lever J assumes its normal position, and prevents downward movement of the lever I until the lever J is again depressed by the passage of an actuating member through the guide F for permitting action of the lever I.

It is thus apparent that, when an actuating member passes through the guide F, said member is, by the operation of the lever I, fed to the receptacle a^{14} , and two additional actuating members stored within the guide G are also fed to said receptacle, thus permitting the re-passage of three actuating members through my improved game apparatus, and increasing the liability of the player securing counting members of the game apparatus, as will be presently described. It is also evident that the actuating members are only fed from the game apparatus by the passage of an actuating member through the way or guide F, and that, after the passage of one member through said way or guide and the discharge of said member and two additional actuating members from the feeding way or guide G, no additional manipulation of the lever I is permitted, and the feeding of additional actuating members from said guide G is absolutely prevented.

As clearly seen at Figs. 3 and 8 the central portion of the feeding way or guide G is inclined downwardly from its right-hand end, and the upper end of said central portion of the feeding way or guide G is connected by an opening g' to the lower end of the way or guide F', thus permitting entrance into the way or guide G of actuating members passed along the guide F'. The actuating members passing along the guide F' are also free to escape from its lower end through an opening f^3 therein into the base of the game apparatus, or into a suitable receptacle, not illustrated, provided therein, or are free to pass through an opening f^4 into the upper end of the auxiliary or second feeding way or guide G', the lower end of which is connected to the lower end of the right-hand downturned extremity of the feeding tube G.

In order that the actuating members fed into the auxiliary feeding way or guide G' may pass regularly and positively into the adjacent end of the feeding way or guide G and be thence elevated to the upper extremity of the central portion thereof, I provide my improved game apparatus with a regu-

lator L and a rocking shifting lever M projecting into the base of the auxiliary feeding way or guide G', and extend the right-hand end of the lever K' to the adjacent end of the feeding way or guide G, and provide said end of the lever K' with an arm K^5 movable in said adjacent end of the way or guide G.

When the lever K' is in its normal position the arm K^5 , which is preferably supported upon a spring K^6 carried by the lever K' is in its elevated position, and supports the actuating members above said arm and within the corresponding end of the feeding way or guide G. As the lever I is depressed, as previously stated, the arm K^5 is also depressed, and a suitable spring G^3 secured to the feeding way or guide serves to prevent downward movement of the actuating members previously supported by the arm K^5 .

The regulator L is pivoted at l to the auxiliary feeding way or guide G', and is provided with upper and lower arms or projections l' l^2 movable alternately into and out of said way or guide G'. The right-hand end of the lever K' provided with the arm K^5 is forked, and the inner branch of said forked end engages the regulator L beneath its pivot l for normally forcing said regulator L to such position that its upper arm l' is within the feeding way or guide G', and prevents downward movement of the superimposed actuating members.

As the lever K' is depressed, as previously stated, the lower end of the regulator L and the weight of the actuating member superimposed above the arm l' forces said arm out of the feeding way or guide G', and the lower arm l^2 then passes within said feeding way or guide, and prevents further downward movement of the actuating members which immediately feed through the way or guide G' into engagement with said arm l^2 . As the lever K' is elevated by the spring K^4 the regulator L is rocked on its pivot l by engagement with said lever until the upper arm l' of the regulator is forced within the way or guide G' for preventing downward feeding of the actuating members above said arm, and the lower arm l^2 is forced from said way or guide G' for permitting downward feeding of the single actuating member beneath the arm l' .

The rocking shifting lever M is pivoted at m at the base of the auxiliary feeding way or guide G', and the adjacent end of the feeding guide G, and is provided with an arm m' movable within the base of the feeding way or guide G' for forcing the actuating member fed downwardly from the regulator L, against the outer or front face of the adjacent downturned end of the feeding way or guide G, and said lever M is provided with an arm m^2 in the path of the lower end of the lever K' . As the lever K' is depressed, as previously stated, by the lever K and operates the regulator L, the arm K^5 bears against the outer or front face of the actuating member fed to the base of the way or

guide G' by the previous movement of the lever K' and the regulator L actuated by said lever K', and said arm K⁵ is free to move outwardly, owing to its securement upon the spring K⁶.

When the lever K' is at the extreme end of its downward movement, the arm K⁵ passes beneath the actuating member, previously engaged thereby, and the spring K⁶ then forces said arm to its operative position, and at the instant that said arm passes beneath said actuating member the lower end of the lever K' depresses the arm m² of the lever M, and the upper arm m' of said lever engages and forces forwardly said actuating member in order that, as the lever K' ascends by the action of the spring K⁴, the said actuating member may be elevated above the spring G³ by the arm K⁵. It will thus be readily apparent that the continued movement of the lever K' regulates the passage of the actuating members from the auxiliary feeding way or guide G' to the feeding way or guide G, and forces the actuating members fed from said auxiliary way or guide G', upwardly through the right-hand downturned extremity of the way or guide G to the central inclined portion of said guide G, and maintains a constant supply of actuating members within the feeding way or guide G. It is also evident, that if the central portion of the feeding way or guide G is filled, the uppermost actuating member fed upwardly by the lever K' passes upwardly through the opening g', and thence outwardly through the opening f³ to the base of the game apparatus or the receptacle, not illustrated, therefor, or passes through the opening f⁴ to the upper end of the feeding way or guide G.

It will be noted that the transparent panels a⁶ a⁷ in the front wall a of the case A are arranged directly in front of the central portion, and the right-hand downturned extremity of the feeding way or guide G for enabling observation of the movement of the actuating members therein.

N is a receptacle containing a series of counting members n, and provided at its base with an outlet opening n' in which is movable the inner end of a feed or plunger N' having its outer end projecting through the front wall of the case A. This feed N' is normally locked from operative position by a stop lever O pivoted at o to a suitable support, and having one end engaged with a notch n² in the feed plunger N', and the other projecting within the way or guide F'.

The inner end of the notch n² is formed with a substantially perpendicular lower end, and with an inwardly inclined upper end, and directly beneath the end of the lever O projecting within the way or guide F' in a spring O'. As an actuating member descends through the way or guide F' it depresses the end of the lever O projecting within said way or guide until further movement of said lever O is prevented by the spring O', and it

elevates the opposite end of the lever from engagement with the vertical portion of the inner wall of the notch n² in the feeding plunger N'. The player then engages the feed or plunger N', and withdraws the same, and, as said plunger is withdrawn, the upper inclined end of the inner wall of the notch n² elevates the adjacent end of the lever O, and depresses the opposite end of said lever against the action of the spring O' for permitting the onward passage of the actuating member within the way or guide F'. At the same time a shoulder n³ on the feed or plunger N' engages the lowermost counting member, and feeds the same through the outlet opening a¹³ in the front wall a of the case A.

It will be evident to any one skilled in the art that any suitable counting member may be used, and that, if desired, the counting members may consist of a series of sections of a strip wound upon a drum, not illustrated, within the case A, and fed by suitable feeding and cutting mechanism from said case.

It is extremely desirable to count the actuating members fed from my improved game apparatus, especially when I use a counting mechanism as D for counting the members fed within the same, and consequently at the rear of the lower end of the plate E I provide a suitable counting mechanism P consisting of indicating wheels p p' having a series of indicating numerals or characters on their faces adapted to register with the openings a¹⁰ a¹¹ in the front wall a of the case A, and a lever p² provided upon the shaft of the disk p, and having one end connected by a link p³ to the lever I and the other provided with a suitable dog p⁴ for engaging a ratchet wheel p⁵ at the rear of the disk p. The shaft of the disk p is provided with an arm or single tooth p⁶, which engages a ratchet p⁷ at the rear of the disk p', and rotates the same a single tooth at each revolution of the disk p⁵.

As will be readily understood from the foregoing description and upon reference to the drawings the operation of my invention is as follows: The actuating members are fed within the game apparatus, and, if of insufficient weight, do not pass therethrough, but, if of normal weight, pass through the chute B, and are counted by the counting mechanism D and then pass between the projections of the plate E, and into one of the diverging ways F F'. If the actuating member passes through the way F the player is notified by the alarm H, the lever J is partially depressed, and the lever I is then free to be operated by the player, and, when operated, effects the discharge into the receptacle a¹⁴ of three of the actuating members, which are then re-passed through the chute B. If the actuating member passes into the way F' the feed for the counting members is free to be operated, and said actuating member then passes to the main or auxiliary feeding ways or guides, or to a suitable receptacle within the game apparatus. As the lever I is operated

to discharge three actuating members from the game apparatus the lever K' serves to maintain the supply of actuating members within the feeding way or guide G and also operates to count the actuating members fed from the game apparatus.

It will be readily understood by one skilled in the art that my present invention may be used as a vending machine. It is evident, however, that the detail construction of the parts of my improved game apparatus may be considerably varied without departing from the spirit of my invention, hence I do not herein specifically limit myself to such construction and arrangement.

Having thus fully described my invention, what I claim as new, and desire to secure by Letters Patent, is—

1. In a game apparatus, the combination with a plate having a series of pins or projections forming a series of ways or guides for the actuating members, separate diverging ways or guides leading from the ways formed by said pins, a movable part in the path of the actuating member, and counting mechanism controlled by the action of said movable part, substantially as and for the purpose described.

2. In a game apparatus, the combination with an inclosing case, a chute leading within the case for conducting the actuating members within the same, a movable part projecting within the chute, counting mechanism controlled by the action of said movable part, and diverging ways beneath the chute, one way discharging within the case and the other at the outside of the same, substantially as and for the purpose specified.

3. In a game apparatus, the combination with an inclosing case, separated openings in one of the upright walls thereof, a chute interposed between said openings and leading within the case for conducting the actuating members therein, a movable part consisting of a revoluble wheel having arms projecting within said chute and actuated by said actuating members, indicating wheels having their indicating faces aligned with the openings of said case, connecting mechanism between said movable part and the indicating wheels, whereby said indicating wheels are actuated by the movement of said revoluble wheel and diverging ways beneath the chute for receiving the actuating members, one way discharging within the case and the other at the outside of the same, substantially as and for the purpose, described.

4. In a game apparatus, the combination with an inclosing case, having separated openings in one of its upright walls, a chute interposed between said openings and provided with a cutout in one wall thereof and a downwardly deflected arm at the base of said cutout projecting laterally from the outer face of said wall of the chute, a movable gate hinged at the opposite side of the chute and disposed in substantially the same plane as

said arm, and having one end arranged normally in the path of the actuating members and its opposite end provided with a counterbalance, a movable part consisting of a revoluble wheel arranged beneath the gate and having arms projecting within said chute, indicating wheels arranged on opposite sides of the revoluble wheel and aligned with the openings in said case, and connecting mechanism between said revoluble wheel and indicating wheels, whereby said indicating wheels are actuated by the movement of said revoluble wheel, substantially as and for the purpose described.

5. In a game apparatus, the combination of a plate or support over which the actuating members are movable provided with a series of separated bearing surfaces for making contact with said members, a series of pins or projections on said plate or support for deflecting the actuating members, and ways or guides leading to and away from said plate or support, substantially as and for the purpose described.

6. In a game apparatus, the combination with a series of pins or projections forming a series of ways or guides for the actuating members, diverging ways or guides leading from the ways formed by said pins, a movable part in the path of the actuating member, a feeding way connected to one of said diverging ways, and counting mechanism, substantially as described, for counting the actuating members passed through said feeding way, substantially as described.

7. In a game apparatus, the combination of a receptacle containing a number of the counting members of the game, a movable feed for feeding said members from the receptacle, diverging ways or guides for the actuating members of the game, a movable lever connected to normally lock said feed from operation and projecting into one of said ways or guides for making contact with the actuating members to release the feed, substantially as and for the purpose specified.

8. In a game apparatus, the combination of a receptacle containing a number of the counting members of the game, a movable feed for feeding said members from the receptacle, diverging ways or guides for the actuating members of the game, a movable lever having one end connected to normally lock said feed from operation and the other end arranged within one of said ways or guides, whereby the passing actuating member rocks said lever and releases said feed, and is prevented from further movement by said lever, and an inclined shoulder on said feed for rocking said lever out of the path of the actuating member and permitting its onward movement, substantially as and for the purpose described.

9. In a game apparatus, the combination with a series of pins or projections forming a series of ways or guides for the actuating members, diverging ways or guides leading from the ways formed by said pins, a recep-

tacle containing a number of the counting members of the game, a movable feed for feeding said members from the receptacle, a movable lever having one end connected to normally lock said feed from operation and the other arranged within one of said diverging ways, whereby the passing actuating member rocks said lever and releases said feed, and is prevented from further movement by said lever, and a shoulder on said feed for rocking said lever out of the path of the actuating member and permitting its onward movement, substantially as and for the purpose specified.

10. In a game apparatus, the combination of a receptacle containing a number of the counting members of the game, a plunger having one end movable at the base of the receptacle and formed with a shoulder for engaging the lowermost member, said plunger being provided with a slot or groove having one wall formed with an inclined portion, diverging ways or guides for the actuating members of the game, and a lever having one end movable in one of said ways or guides and the other registered in said slot or groove, substantially as and for the purpose described.

11. In a game apparatus, the combination with a series of pins or projections forming a series of ways or guides for the actuating members, separate diverging ways or guides leading from the ways formed by said pins and formed with downwardly turned extremities, an alarm, and a movable part projecting into one of said diverging ways or guides and connected to said alarm for operating the same, substantially as and for the purpose specified.

12. In a game apparatus, the combination with diverging ways or guides for the actuating members having discharge openings, a feeding way or guide having a discharge opening, a feed regulator movable in the feeding way or guide for regulating the passage therethrough, a lever having a hand engaging portion and connected to operate said feed regulator, a stop for said lever having an engag-

ing end projecting into one of the diverging ways or guides for making contact with the actuating members passed therethrough and counting mechanism connected to said lever, substantially as and for the purpose specified.

13. In a game apparatus, the combination with a way or guide having a discharge opening, a feeding way or guide having a discharge opening, a regulator lever having separate arms movable in the feeding way or guide for controlling the passage therethrough, a lever connected to actuate the former lever, a third or stop lever having a shoulder projecting within the former way or guide for making contact with the actuating member passing therethrough, said lever being formed with separate shoulders for engaging the second lever, and a spring connected to said levers for returning the same to their operative position, substantially as and for the purpose described.

14. In a game apparatus, the combination with diverging ways or guides for the actuating members having discharge openings, a feeding way or guide having a discharge opening, a feed regulator movable in the feeding way or guide for regulating the passage therethrough, a lever having a hand engaging portion and connected to operate said feed regulator, a stop for said lever having an engaging end projecting into one of the diverging ways or guides for making contact with the actuating members passed therethrough and means, substantially as described, for feeding the actuating members into said feeding way or guide, substantially as and for the purpose specified.

In testimony whereof I have hereunto signed my name, in the presence of two attesting witnesses, at Syracuse, in the county of Onondaga, in the State of New York, this 15th day of May, 1893.

JOHN R. ROWLANDS.

Witnesses:

CLARK H. NORTON,
E. A. WEISBURG.

Correction in Letters Patent No. 523,712.

It is hereby certified that the last named assignee in Letters Patent No. 523,712, granted July 31, 1894, upon the application of John R. Rowlands, of Syracuse, New York, for an improvement in "Game Apparatus," was erroneously written and printed "Walton H. Wales," whereas said name should have been written and printed *Walter H. Wales*; and that the said letters patent should be read with this correction therein that the same may conform to the record of the case in the Patent Office.

Signed, countersigned, and sealed this 9th day of April, A. D., 1895.

[SEAL.]

JNO. M. REYNOLDS,
Assistant Secretary of the Interior.

Countersigned:

JOHN S. SEYMOUR,
Commissioner of Patents.