

J. A. LITTLE.

Improvement in Scrubbers and Scrapers.

No. 130,925.

Patented Aug. 27, 1872.

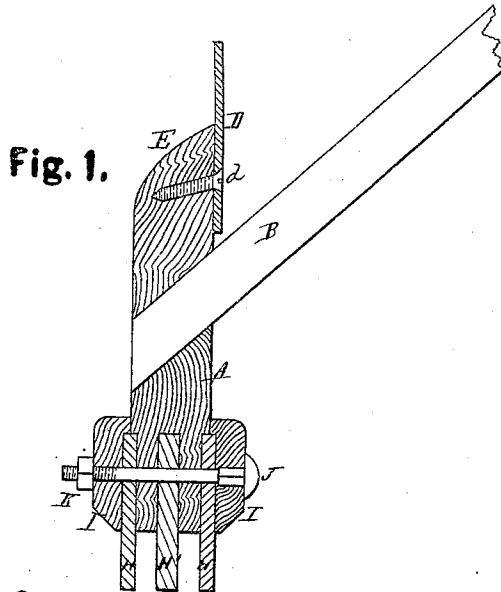
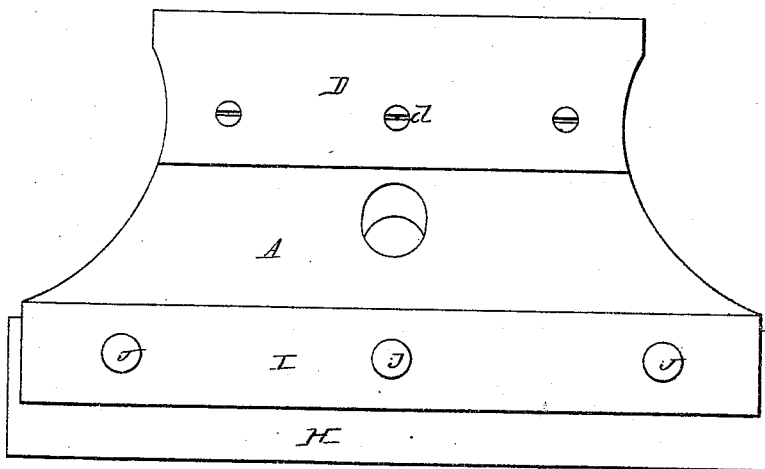

Fig. 2.



WITNESSES.
E. A. Bates
Phil. C. Mosier

INVENTOR.
James A. Little
Chapman & Hosmer & Co
Attys

UNITED STATES PATENT OFFICE.

JAMES A. LITTLE, OF CARTERSBURG, INDIANA.

IMPROVEMENT IN SCRUBBERS AND SCRAPERS.

Specification forming part of Letters Patent No. 130,925, dated August 27, 1872.

To all whom it may concern:

Be it known that I, JAMES A. LITTLE, of Cartersburg, in the county of Hendricks and State of Indiana, have invented a new and valuable Improvement in Scrubbers and Scrapers; and I do hereby declare that the following is a full, clear, and exact description of the construction and operation of the same, reference being had to the annexed drawing making a part of this specification, and to the letters and figures of reference marked thereon.

Figure 1 of the drawing is a representation of a sectional view of my invention. Fig. 2 is a front view of my invention.

My invention has relation to a combined India-rubber scrubber and metallic scraper; and consists in the construction and novel arrangement of the tongued wooden head cleats and bolts, scraper, and rubber strips, whereby a very useful instrument is produced at little expense, as hereinafter described.

In the drawing, A represents the head of the implement, consisting of a piece of board of some suitable general shape, as shown, and having one end beveled, as at E, and a metallic plate, D, secured to the side and extending beyond the edge of said end. B designates a handle. The handle is inserted from the side holding the scraper-plate D, and lies at an angle of about forty-five degrees to said plate. The object of the beveled surface E is to allow the head A to be tilted to the proper

position for use, when the handle will be elevated sufficiently above a horizontal position and the scraper brought to its work at an angle. The opposite edge of the head A holds several strips of India rubber, H H H'. The middle piece is inserted in a recess cut in the head and the two side pieces held by means of recessed cleats I. Bolts J, with nuts K, secure the strips and cleats, and allow the strips to be adjusted according as they become worn.

The implement is used as a rubber by inverting the head A, so that the edges of the strips shall perform the work required, said strips being in a vertical position and all touching at the same time.

What I claim as my invention, and desire to secure by Letters Patent, is—

The implement described, consisting of an oblique handle and a wooden head, beveled at one edge parallel with said handle and toward the scraper-plate, and provided at the opposite edge with the fixed-rib, removable cleats, bolts, and rubber strips, substantially as specified.

In testimony that I claim the above I have hereunto subscribed my name in the presence of two witnesses.

JAMES A. LITTLE.

Witnesses:

SUDIE OSBORNE,
TAYLOR WILLS.