



US007898987B2

(12) **United States Patent**  
**Weigl et al.**

(10) **Patent No.:** **US 7,898,987 B2**  
(45) **Date of Patent:** **\*Mar. 1, 2011**

(54) **METHOD AND DEVICE FOR THE EXCHANGE OF DATA BETWEEN AT LEAST TWO USERS CONNECTED TO A BUS SYSTEM**

5,666,358 A 9/1997 Paratore et al.  
5,694,542 A 12/1997 Kopetz  
6,061,600 A 5/2000 Ying  
6,208,653 B1 3/2001 Ogawa et al.  
6,611,860 B1 8/2003 Ying

(75) Inventors: **Andreas Weigl**, Linkenheim-Hochstetten (DE); **Thomas Fuehrer**, Gerlingen (DE); **Bernd Müller**, Leonberg (DE); **Florian Hartwich**, Reutlingen (DE); **Robert Hugel**, Karlsruhe (DE)

**FOREIGN PATENT DOCUMENTS**

EP 0 560 122 9/1993  
EP 0 650 106 4/1995

(73) Assignee: **Robert Bosch GmbH**, Stuttgart (DE)

**OTHER PUBLICATIONS**

(\* ) Notice: Subject to any disclaimer, the term of this patent is extended or adjusted under 35 U.S.C. 154(b) by 439 days.

Banetjee S. et al., "A Time Driven Controller Area Network for Reliable Automation", Indian Journal of Power and River Valley Development, Books and Journals Private, Ltd., In, Jan. 1997, vol. 47, No. 1-2, pp. 6-8.

This patent is subject to a terminal disclaimer.

Berwanger J. et al., "Byteflight—Neues Hochleistungs-Datenbus-system für sicherheitsrelevante Anwendungen", Automotive Electronics Handbook, Jan. 2000, pp. 60-67.

(21) Appl. No.: **11/435,815**

Führer T. et al., "Time Triggered Communication on CAN (Time Triggered CAN- TTCAN)", Proceedings of the International CAN Conference, 2000, pp. 1-7.

(22) Filed: **May 16, 2006**

(65) **Prior Publication Data**

*Primary Examiner*—Pankaj Kumar

US 2006/0203748 A1 Sep. 14, 2006

*Assistant Examiner*—Hicham B Foud

**Related U.S. Application Data**

(74) *Attorney, Agent, or Firm*—Kenyon & Kenyon LLP

(62) Division of application No. 09/755,866, filed on Jan. 5, 2001, now Pat. No. 7,075,898.

(57) **ABSTRACT**

(30) **Foreign Application Priority Data**

A method for exchanging data in messages between at least two users connected by a bus system, where each of the at least two users includes a predefinable and/or ascertainable timing mark, includes causing the at least two users to transmit, via the bus system, messages including the data. The method also includes causing a first user, in a function as timer, to control the messages as a function of time in such a way that it repeatedly transmits a reference message, which contains time information of the first user, via the bus at a specifiable time interval. Further, if the timing mark of the second user is reached without a reference message of the first user reaching the second user, the second user is caused to take over the function of timer by transmitting its own reference message with its own time information via the bus system.

Jan. 5, 2000 (DE) ..... 100 00 304

(51) **Int. Cl.**

**H04L 12/28** (2006.01)  
**H04L 12/42** (2006.01)  
**H04B 7/212** (2006.01)  
**H04J 3/06** (2006.01)

(52) **U.S. Cl.** ..... 370/257; 370/444; 370/451; 370/503

(58) **Field of Classification Search** ..... None  
See application file for complete search history.

(56) **References Cited**

**U.S. PATENT DOCUMENTS**

4,393,458 A 7/1983 Fung

**12 Claims, 6 Drawing Sheets**

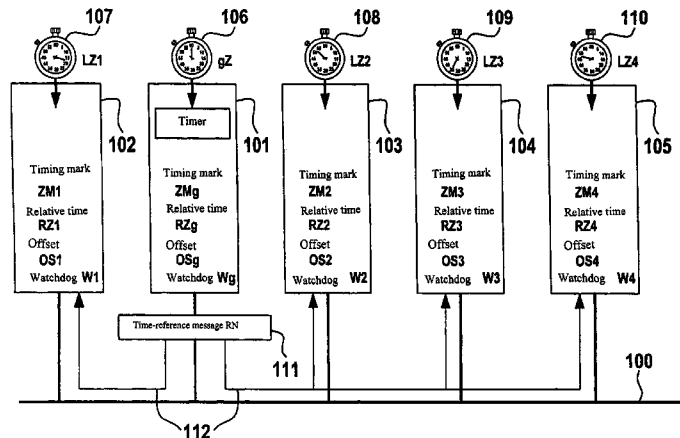

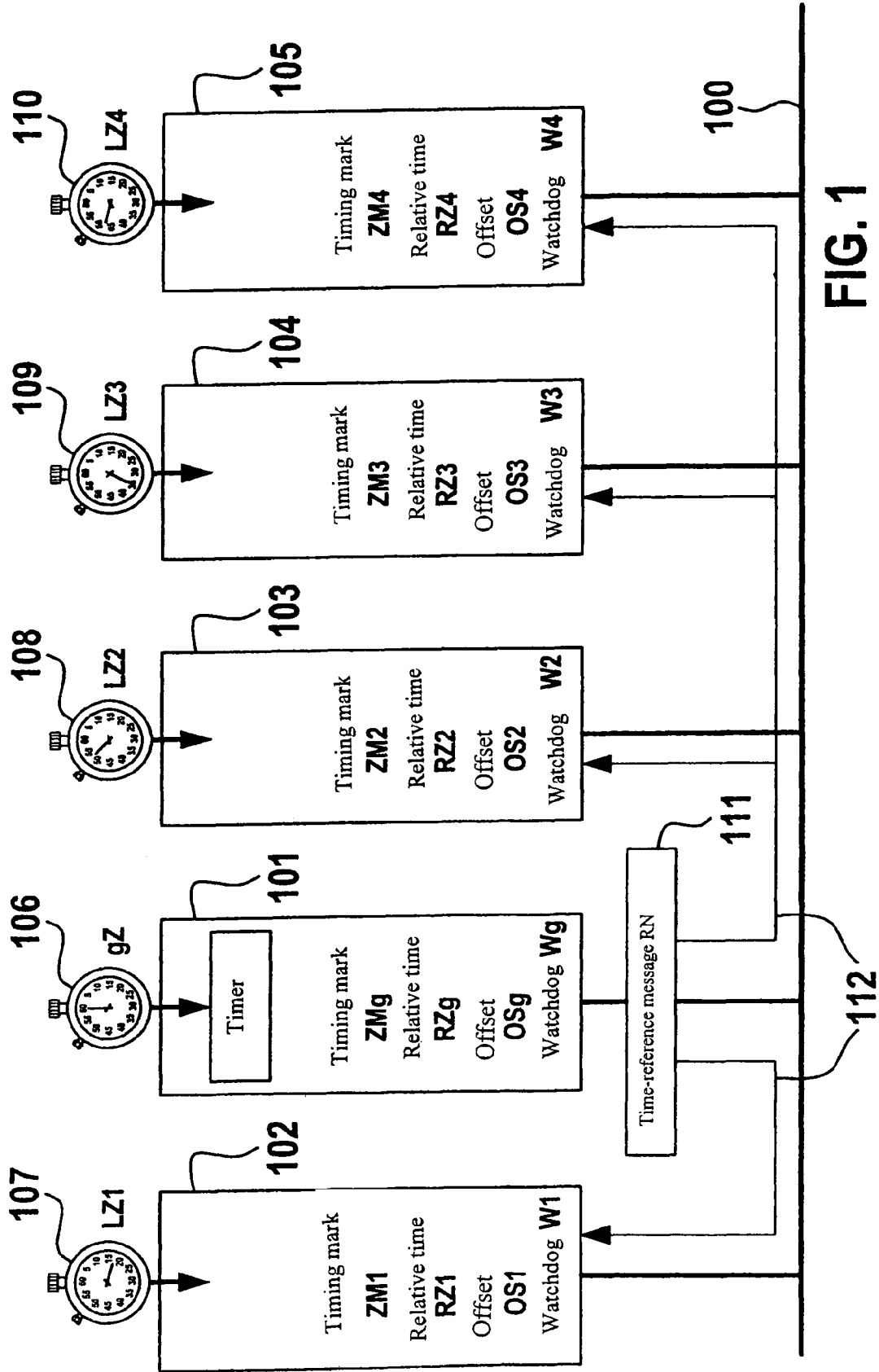
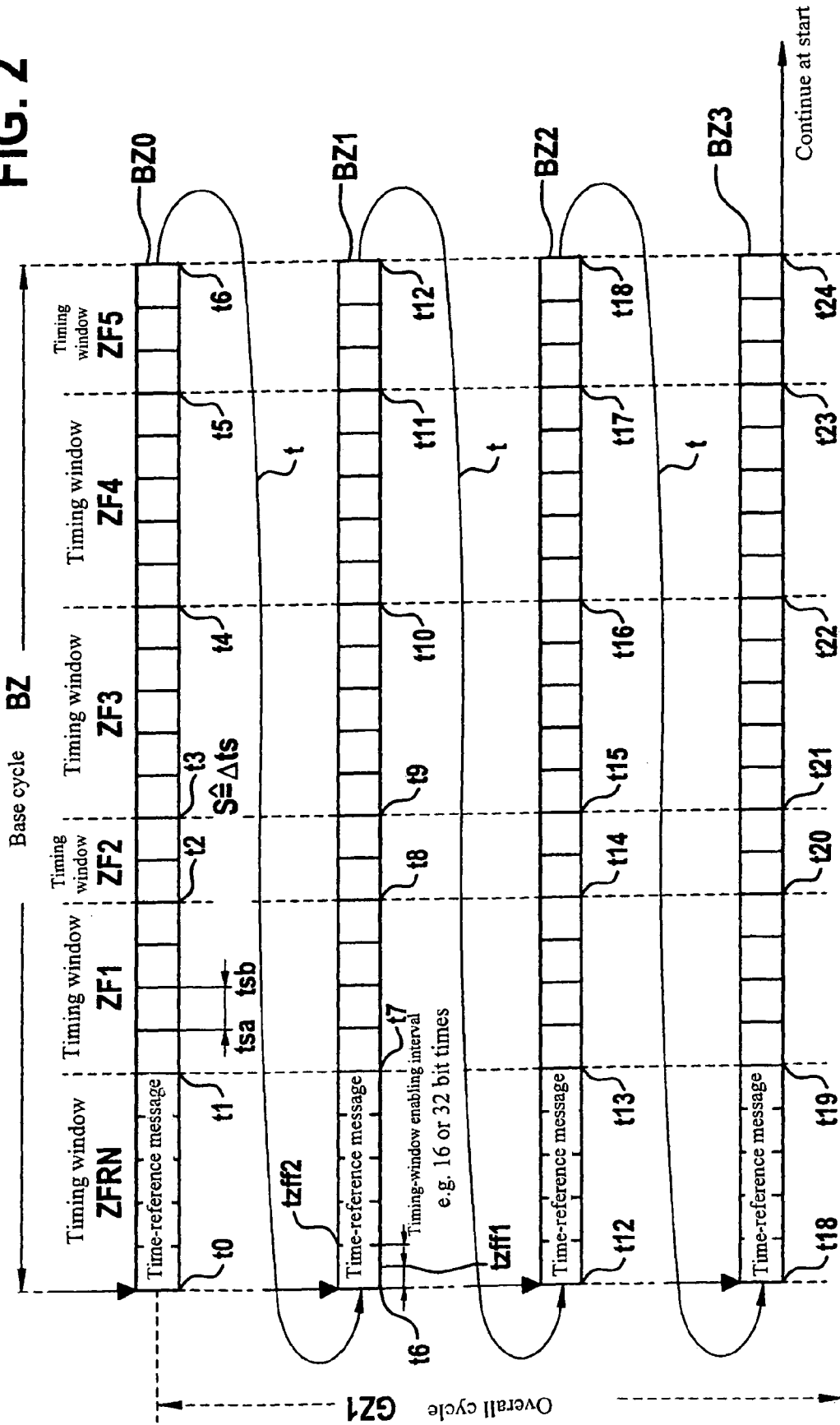

FIG. 1

FIG. 2







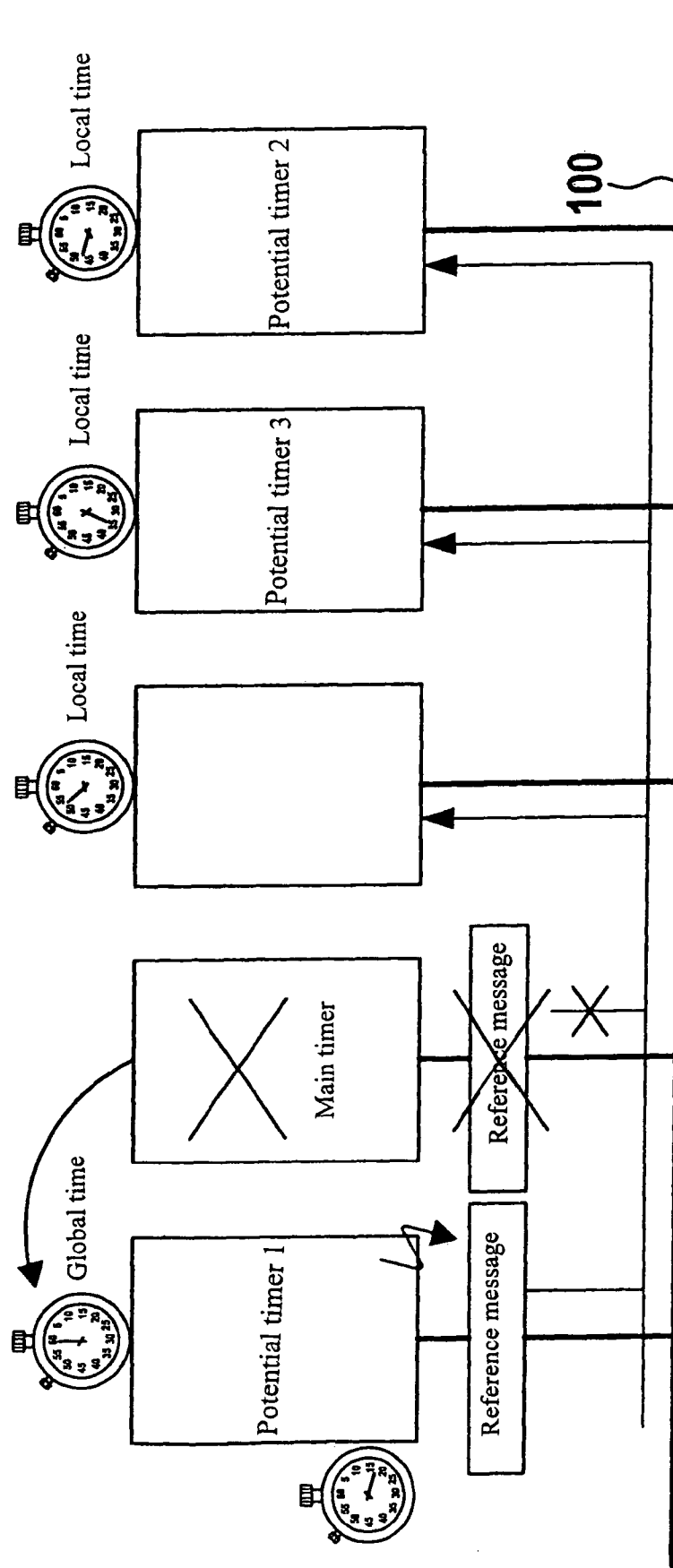

FIG. 5

Distributed timers

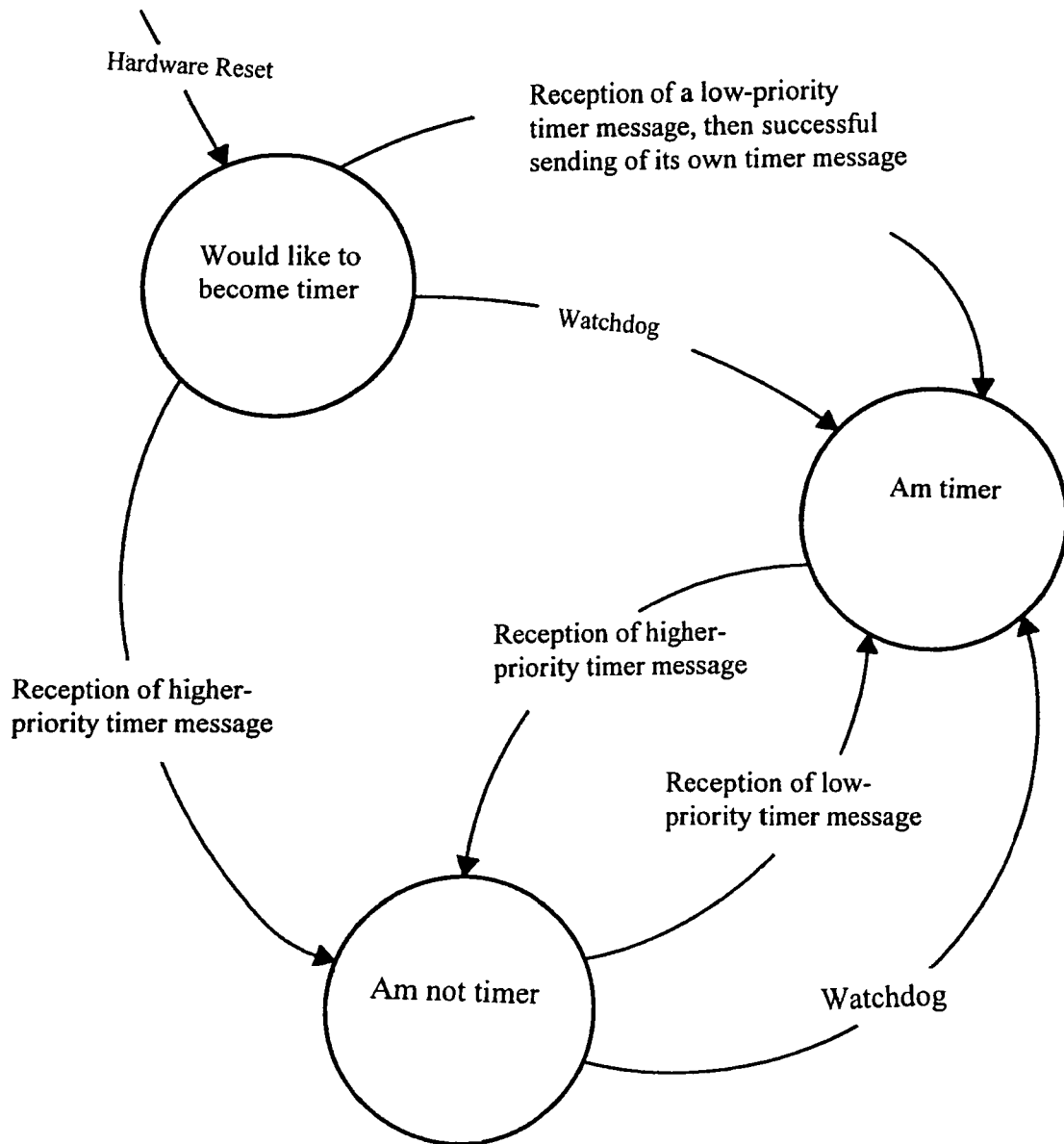

FIG. 6

1

**METHOD AND DEVICE FOR THE  
EXCHANGE OF DATA BETWEEN AT LEAST  
TWO USERS CONNECTED TO A BUS  
SYSTEM**

CROSS-REFERENCE TO RELATED  
APPLICATION

This application is a division of prior U.S. patent application Ser. No. 09/755,866 filed Jan. 5, 2001 now U.S. Pat. No. 7,075,898 of which is expressly incorporated herein in its entirety by reference thereto.

FIELD OF THE INVENTION

The present invention relates to a method and a device for the exchange of data between at least two users (nodes) connected to a bus system.

BACKGROUND INFORMATION

As related art in automotive networking, the CAN (controller area network) protocol has been used for several years. In that case, the communication is controlled in an event-driven manner. Very great loads can be produced when the transmission of various messages is to be initiated at the same time. The non-destructive arbitration mechanism of CAN guarantees the sequential transmission of all messages according to the priority of their identifiers or identifications. For hard real-time systems, an analysis of the transit times and bus loads for the entire system is made in advance, to make sure that all message deadlines can be observed (even under peak load).

There are already communication protocols which are based on time-controlled processing, such as TTP/C or Interbus-S. The exceptional feature in this case is that the bus access is already planned in advance by allocating transmission instants. Thus, no collisions can occur during the transit time. However, in the same way, a peak load is avoided on the communications bus. Thus, the bus is frequently not completely utilized to capacity.

In the case of the TTP/C protocol, the time information is distributed by allocation of the communication objects to the global time and adjustment of the local time of the individual users by fault-tolerant averaging of all time information.

Other bus protocols derive the time information from the individual bits of a message.

Consequently, a controlled run-up of the system that is as rapid as possible is not ensured in every case. In the same way, the entire system can collapse if the time-giving user malfunctions. Furthermore, automatic resumption of the function is not always ensured after the malfunction.

It is apparent that the related art is unable to deliver optimal results in every respect.

SUMMARY OF THE INVENTION

Thus, the present invention advantageously includes a method and a device for the exchange of data in messages between at least two users which are connected by a bus system, the messages containing the data being transmitted by the users via the bus system, and each user containing a predefinable and/or ascertainable timing mark; a first user, in a function as timer, controls the messages as a function of time in such a way that it repeatedly transmits a reference message, which contains time information of the first user, via the bus at a specifiable time interval, and if the timing mark of

2

the second user is reached without a reference message of the first user reaching the second user, the at least second user takes over the function of timer by transmitting its own reference message with its own time information via the bus system.

In this context, the CAN bus is used particularly expediently as the basic bus system or bus protocol. However, the present invention relates generally to any bus system or bus protocol in which an object-oriented message transfer or data transfer is used, thus the message and/or the data contained therein are clearly recognizable by an identifier. Consequently, this is valid for all busses in which not the users, but rather the messages or their data are addressed, in particular the CAN bus.

Advantageously, various users, particularly all users, are potentially provided as timers, and these users can transmit their own reference messages with time information of their own via the bus when the user's own timing mark has been reached without a reference message having been received.

The messages are advantageously controlled by a first user as a function of time in such a way that the first user repeatedly transmits a reference message via the bus at at least one predefinable time interval, and the time interval is subdivided into timing windows of specifiable length, the messages being transmitted in the timing windows.

Therefore, compared to the related art, the present invention advantageously includes a higher protocol layer with respect to the actual bus (CAN) protocol which is retained unchanged within the framework of the time-controlled communication according to the present invention. Thus, the time-controlled communication advantageously allows full capacity utilization of the bus, and at the same time makes it possible to hold the latency times for each message to a defined value.

The present invention therefore includes a cyclically proceeding transfer of bus (CAN) messages. In this manner, a deterministic and combinable communication system is produced. Such a system is subsequently referred to as TTCAN in the present invention. Furthermore, in the same way, the starting point is a CAN bus, the considerations being valid generally for all bus systems or bus protocols having object-oriented message transfer, as mentioned above.

The reference message and the subsequent timing windows up to the next reference message are expediently combined to form a first cycle of specifiable length and/or specifiable structure, the structure corresponding to the length, number and time position of the timing windows in the time interval which follow the reference message.

Furthermore, a plurality of first cycles of the same structure are advantageously combined to form a second cycle, messages in the second cycle also being repeatedly transmitted in timing windows whose time interval is greater than the time length of the first cycle.

One cyclical message transfer is expediently omitted in at least one timing window of the first or the second cycle. In these initially empty timing windows, it is then possible to transfer arbitrating messages, thus such which do not have to be transmitted cyclically, but rather are available when, for example, certain sequences are concluded.

A priority with respect to the timer function can expediently be assigned to the users potentially used as timer, that user advantageously initially taking over the function as timer for the first cycle whose timing mark is reached first without the user having received a reference message, and in the following first cycle of the second cycle, that user having the

highest priority taking over the function as timer. In this manner, the priority of the timers is expediently configurable (logical sequence).

The aforesaid measures advantageously ensure the timer function and the orderly communications sequence or message exchange over time after the initialization or in the event of the malfunction of a timer in a time-controlled bus system, particularly a CAN bus system (TTCAN).

A further advantage is the controlled, fastest possible runup of the system, composed of users and bus system, obtained in this case. A system collapse in response to the malfunction of a timer (node) is expediently avoided, and automatic resumption of the function is ensured after a malfunction.

#### BRIEF DESCRIPTION OF THE DRAWINGS

FIG. 1 shows schematically a bus system having a plurality of users.

FIG. 2 shows the sequence in principle of the first cycles or base cycles and the second cycles, the overall cycles over time.

FIG. 3 illustrates in detail the design and message occupancy of the timing windows.

FIG. 4 then shows an overall cycle having 7 base cycles and diverse transmission groups of messages, as well as arbitrating messages.

FIG. 5 shows, by analogy with FIG. 1, the transfer of the timer function to a further user which is designed as a potential timer.

FIG. 6 shows, in a state diagram, various possibilities for the transfer of the timer function in view of the timer priorities.

#### DETAILED DESCRIPTION

TTCAN is based on a time-controlled, periodic communication which is clocked by a timer (node, user) with the aid of a time-reference message, or reference message RN for short. The period up to the next reference message RN is denoted as base cycle and is subdivided into n timing windows (see FIG. 2). Each timing window allows the exclusive transmission of one periodic message of variable length. These periodic messages are transmitted in a TTCAN controller by using timing marks which are coupled to the expiration of a logical relative time. However, TTCAN also allows the consideration of vacant timing windows. These timing windows can be used for so-called spontaneous messages, the access within these timing windows to the bus being utilized via the arbitration scheme of CAN (arbitrating messages). The synchronization of the timer clock (global time gZ) with the internal local time of individual nodes 1Z1 through 1Z4 is taken into account and efficiently converted.

FIG. 1 shows a bus system 100 having a plurality of bus users 101 through 105. In this context, each user 101 through 105 has a separate time base 106 through 110 which can be transmitted, on the one hand, by an internal element such as a clock, counter, clock generator, etc., or externally to the respective user. The respective local time base 1Z1 through 1Z4 is, in particular, a counter, for example, a 16-bit incrementing, which may only be influenced by a HW reset. In this instance, the local time base is implemented in each node or user 102 through 105. One user, the timer, 101, has an exposed setting. Its time base is designated as global time base 106 having global time gZ, and is either implemented in timer 101, or is transmitted to it externally. Global time gZ is formed in principle in each node from local time base 107

through 110, i.e. local time 1Z (1Z1 through 1Z4) and an offset OS1 through OS4. As a rule, this offset OSg for timer 101 is equal to zero (OSg=0). All other nodes form their view of global time gZ from local time 1Z (1Z1 through 1Z4) and local offset OS1 through OS4 and OSg, when OSg≠0. The case when OSg is not zero occurs, for example, when global time gZ is transmitted from the outside to timer 101 which, in addition, contains its own time base 106. Then, the timer is also calibrated to global time gZ, and gZ and time base 106 may not agree. The local offset is the difference between the local time at the transmission instant (SOF, start of frame) of the reference message, and the global time transmitted by the timer in this reference message.

#### Local Time Base and the Global Time

Local Time Base: The local time base is a counter, such as a 16-bit incrementing, which may only be influenced by a HW reset. The local time base is implemented in each node.

Reference-Mark Buffer Register: In response to each assumed SOF, the buffer register is loaded with the local time base.

Reference Marker: If the instantaneous message is recognized as a reference message, then the value is retrieved from the buffer register into the reference marker (as local reference mark). The reference marker is configured, for example, as a 16-bit register.

Timer Reference Mark: This is the reference mark of the timer received by the time takers in the reference message.

Local Offset with Respect to the Global Time: The local offset to the global time is the difference between the reference mark in the buffer register and the global timing mark received in the reference message. It is used for calculating the global time from the local time. The offset of the timer itself remains constant. The timer transmits its local reference mark plus the local offset in the reference message.

Thus, timer 101 is also that node or user which transmits time-reference message 111, i.e., reference message RN for short. Arrow 112 indicates that reference message RN 111 is dispatched, especially simultaneously, to remaining users 102 through 105.

Reference message RN is the basis for the time-controlled, periodic operation of TTCAN. It is clearly denoted by a special identifier, and is received by all nodes, here 102 through 105, as clock generator. In principle, it is sent out cyclically by timer 101. The reference message can include the following data: The number of the instantaneous base cycle BZn, the reference mark of the timer in global time.

The reference mark is formed by the takeover of the internal counter reading at the instant of the "start of frame" bit (SOF) upon reception of the reference message of the timer. Thus, the reference mark is an instantaneous recording of the local time base at the instant of receiving the reference message. Relative time RZ1 through RZ4 and RZg specified in the users is the difference between the local time base and the last reference mark. All definitions with regard to the timing marks used relate to the relative time of an individual user. For example, it can be permanently available as a signal (e.g., by combining the two register values via gates). The reference mark determines the relative time of all nodes on the TTCAN bus.

Watchdog Wg and W1 through W4, likewise shown, is a special relative instant. Such a relative instant (watchdog)—at which a new reference message, and thus a reference mark, as well, is expected at the latest—is defined in each node. Therefore, the watchdog represents a special timing mark. The watchdog is used primarily in the initializing and re-initializing to monitor whether a communication has taken

place at all. In this case, the watchdog should always be greater than the interval between the reference messages.

In this context, one timing mark is a relative instant which establishes the relationship between the relative time and an action in the original bus (CAN) controller. One timing mark is represented as a register, a controller having the ability to manage a plurality of timing marks. A plurality of timing marks can be allocated to one message (see, for example, in FIG. 4: transmission group A occurs both in timing window ZF1a, and in timing window ZF4a).

With regard to the application, an application watchdog is actuated in particular. This watchdog is employed regularly by the application in order to signal the proper operation to the TTCAN controller. The messages are sent by the CAN controller only when this watchdog is actuated.

FIG. 2 shows the principle of the time-controlled, periodic message or data transfer over time. This message transfer is clocked by the timer with the aid of the reference message. Time interval t0 through t6 is designated as base cycle BZ and is subdivided into k timing windows ( $k \in \mathbb{N}$ ). Reference messages RN of respective base cycles BZ0 through BZ3 are transmitted from t0 to t1, t6 to t7, t12 to t13 and t18 to t19, thus in timing window ZFRN. The structure of timing windows ZF1 through ZF5 following a reference message RN, thus their length (in segments S, where  $\Delta t_s = t_{sb} - t_{sa}$ ), their number and their time position, is specifiable. In this manner, an overall cycle GZ1 which begins at t0 and ends at t24, to be run through anew, can be formed from a plurality of base cycles of the same structure. For example, the timing windows include 2 to 5 segments having, for instance, 32 bit times each. The number of timing windows is, for example, 2 to 16, only one timing window or more than 16 also being possible. The number of base cycles in an overall cycle is  $2^m$ , for instance, where, in particular  $m \leq 4$ .

By way of example, tzff1 and tzff2 denote two transmission enabling intervals or timing-window enabling intervals which, for instance, last 16 or 32 bit times and describe the time frame within which it is possible to begin with the transmission of the message with respect to the base cycle.

Each timing window allows the exclusive transmission of a periodic message of variable length. By way of example, FIG. 3 shows two messages of different length and the allocation in the timing window. For instance, message 1 (N1) as block 300 contains 130 bits, and message 2 (N2) as block 301 contains 47 bits.

As already mentioned, maximum and minimum timing windows can be predefined as a function of the message length, for instance, between 2 and 5 segments per timing window in this example. Thus, a maximum timing window ZFmax is predefined as block 302 which includes 5 segments (S1 through S5) having 32 bit times each, and a minimum timing window ZFmin is predefined as block 303 which includes 2 segments (S1 and S2) having 32 bit times each. Messages N1 and N2 are transmitted in them, the messages thus not having to completely fill up the timing windows; rather, the timing-window sizes are specified according to the message length. Therefore, ZFmax offers sufficient time or place for the longest possible message, e.g. 130 bits or bit times, and ZFmin can be adapted to the shortest possible message, e.g. 47 bits.

In general, the timing window is the time frame available for a specific message (see FIG. 3). The timing window of a message is opened with the application of the proceed-to-send signal, and the beginning of this window agrees in principle with a defined timing mark. The length of the timing window is determined from i segments having, for example, 32 bit times (see block 304a). In this context, the segmenting

at, in particular, 32 bit times represents a HW-friendly size. The timing window may not be shorter than the longest message occurring in this timing window. The bit time is, in particular, the nominal CAN bit time.

The transmission enabling interval or timing-window enabling interval describes the time frame within which the transmission of the message may be started. The transmission enabling interval is a part of the timing window. Thus, the proceed-to-send is applied in the interval timing mark and timing mark plus delta. The value delta is perceptibly smaller than the length of the timing window (e.g., 16 or 32 bit times for ZFF1 or ZFF2). A message whose beginning does not lie within the transmission enabling interval may not be sent.

FIG. 4 now represents an overall cycle (transmission matrix) GZ2.

Overall Cycle (Transmission Matrix): All messages (RN, A through F and arbitrating) of all users are organized as components of a transmission matrix (see FIG. 4). The transmission matrix is made up of individual base cycles BZ0a through BZ7a. All base cycles of overall cycle GZ2 have the same structure. These base cycles can be composed selectively from exclusive (A through F) and arbitrating components. The total number of lines (thus base cycles BZ0a through BZ7a) here is a number  $2^m = 8$ , where  $m = 3$ .

One base cycle (line of the transmission matrix) begins with a reference mark in reference message RN and is composed of a plurality (i) of successive timing windows of defined length (first timing window ZFO, i.e., ZFRN for RN). The arrangement of the messages within the base cycle can be freely established. A timing window is linked for exclusive components to a CAN message object. A timing window can also be left free (409, 421, 441, 417, 445) or be used for arbitrating components (403, 427).

Messages which are always sent in the same timing window but in different base cycles form a transmission group (column of the transmission matrix, A through F) (see FIG. 4). Consequently, a period can be established, e.g., A in ZF1a and ZF4a: 401, 407, 413, 419, 425, 431, 437, 443 and 404, 410, 416, 422, 428, 434, 440, 446. One message object (of a timing window) can be sent repeatedly within a transmission group. The period of a message within a transmission group is a number 2, where  $1 <= m$ .

The message object, i.e., the message, corresponds to the message object of the bus, particularly in CAN, and includes the identifier, as well as the data itself. In TTCAN, the message object is supplemented by at least one, preferably by all three, of the following entries in the transmission matrix: timing window, base mark, rate of repetition.

The timing window is the position (ZF0, ZF1a through ZF5a) in the base cycle (BZn, line of the transmission matrix). The beginning of the timing window is defined by reaching a specific timing mark.

The base mark indicates in which base cycle (BZ0a through BZ7a) in the overall cycle the message is sent first.

The rate of repetition defines after how many base cycles this transmission is repeated.

To indicate the validity of a message object for the CAN controller, there is a "permanent transmission request" which signifies a permanent enabling of the object (for exclusive components, see below) and an "individual transmission request" which signifies a one-time validity of the object (for arbitrating components, see below).

The automatic retransmission from CAN is advantageously deactivated for the messages in TTCAN.

In the following, the message transfer—periodic messages and spontaneous messages—in the base cycle or in the overall cycle, particularly with respect to the application, is now

described again. In so doing, exclusive messages, thus periodic messages, and arbitrating, thus spontaneous messages, are again differentiated.

Exclusive Message Objects (Periodic Messages): Exclusive message objects are sent when the application watchdog is set, the “permanent transmission request” of the application is set at the CAN controller, and the transmission enabling interval of the appertaining timing window is open. In this case, the timing mark for the message object agrees with the relative time. The permanent transmission request remains set until it is reset by the application itself.

Arbitrating Message Objects (Spontaneous Messages): Arbitrating message objects are sent when the application watchdog is set, the “individual transmission request” of the application is set at the CAN controller, and the transmission enabling interval of the next timing window specified for this is open. The timing mark for this timing window is then equal to the relative time. The transmission request is reset after successful transmission by the CAN controller. The simultaneous access of various spontaneous messages is regulated via the bit arbitration of CAN. If a spontaneous message in this timing window loses versus another spontaneous message, then it can first fight again for bus access in the next timing window specified for this.

If the entire transmission matrix, i.e. the overall cycle is run through, then a cyclical, time-controlled message transmission is yielded. Time-controlled means that each action uses, as a point of departure, the attainment of a specific instant (see timing marks and relative time). If the overall cycle is run through completely, i.e., all base cycles were processed once, then a start is made again with the first base cycle of the transmission matrix. No time gaps arise in the transition. An overview of such a time-controlled communications system with timer has been presented in the description and the figures of the Drawing.

In a TTCAN system, all timing windows in which messages are transmitted relate to a reference instant which is communicated to all users by a reference sender at the beginning of a base cycle.

FIG. 5 shows a system for that purpose by analogy with FIG. 1. The timer is composed, for example, of a local (e.g., 16-bit wide) counter (of the local or global time base), an (e.g., 16-bit wide) offset register, a (e.g., 16-bit wide) reference register and a watchdog timing mark.

In one system, there is a plurality of “potential” timers which, in a predefined priority, are able to send a reference message and thus become timers.

During the run-up of the system after switching on, each node provided for that purpose can assume the timer function.

To that end, the local counter is started and the counter reading is loaded into the reference register. The local counter is running, and either the watchdog mark is reached, or a reference message is received from another node.

If the watchdog mark is reached before a reference message has been received, then this node takes over the timer function by sending a reference message and thus starting a base cycle.

If the node receives a reference message from another node before the watchdog mark has been reached, then it synchronizes itself to this reference and checks whether its own timer priority is higher or lower.

Various possibilities are shown in the state diagram in FIG. 6. In the case of lower priority, this node continues to function as a normal “potential”, but not active timer.

However, if its timer priority is higher than that of the reference message received, as of the next reference instant, it attempts to become the timer.

In this context, there are then the following cases:

a) If the higher-priority timer sends the reference message before the prevailing timer, then it takes over the function of timer, and the previous timer withdraws, since it sees the higher-priority reference message.

b) If both timers transmit simultaneously, then the arbitrating mechanism of the CAN protocol comes into effect, and the higher-priority timer assumes the function of the timer, since the priority is linked to the identifier of the reference message.

c) If the higher-priority timer comes too late, then, in a system without drift correction, it attempts to send its reference message until the message gets through, or the timer receives an even higher priority reference message. In this context, a shift of the global time is put up with. Drift correction means the adjustment of the accuracy of the local clocks distributed in a TTCAN system to synchronize transmission and reception instants more precisely. When working with a system having a drift correction, attempt is again made at the next possible reference instant to assume the timer function. A suitable drift-correction algorithm ensures that, at the latest at the second base cycle, the higher-priority timer does not place its reference message on the bus later than the prevailing timer, and thus wins the arbitration and assumes the timer function.

If the prevailing timer fails, then the watchdogs in the “potential” timers elapse with variable rapidity depending on their priority, and the node whose watchdog elapses first assumes the timer function (see above).

In order that the transition from one timer to the other is as steady as possible in the time, each timer can transmit its view of the global time in its reference message.

The terms time-reference message and reference message are synonymous. A reference message having time information, i.e., the time information in the reference message is then designated as timer message (see FIG. 6).

What is claimed is:

1. A method for an exchange of data in messages between at least two users connected by a bus system, each one of the at least two users including at least one of a predefinable timing mark and an ascertainable timing mark, the method comprising:

causing the at least two users to transmit via the bus system messages including the data;

causing a first one of the at least two users, in a function as timer, to control the messages as a function of time such that the first one of the at least two users repeatedly transmits a first reference message including a first time information regarding a time base of the first one of the at least two users, via the bus system at a specifiable time interval; and

if the at least one of the predefinable timing mark and the ascertainable timing mark of a second one of the at least two users is reached without the first reference message of the first one of the at least two users reaching the second one of the at least two users, causing the second one of the at least two users to take over the function of timer by transmitting a second reference message with a second time information regarding a time base of the second one of the at least two users, via the bus system, wherein one of the first time information and the second time information is used by a receiving user to calculate a global time as a function of a local time information and the one of the first time information and the second time information.

2. The method according to claim 1, further comprising: providing each one of the at least two users as timers; and

9

causing the first one of the at least two users and the second one of the at least two users to transmit via the bus system the first reference message with the first time information and the second reference message with the second time information when the at least one of the predefinable timing mark and the ascertainable timing mark of any of the at least two users has been reached without a receipt of a corresponding one of the first reference message and the second reference message. 5

3. The method according to claim 1, further comprising: subdividing the specifiable time interval into timing windows of a specifiable length; and transmitting the messages including the data in the timing windows.

4. The method according to claim 1, further comprising: allocating a priority with respect to the function as timer to those of the at least two users that are used as a timer. 15

5. The method according to claim 3, wherein the messages are cyclically transmitted.

6. A device for an exchange of data in messages between at least two users connected by a bus system, each one of the at least two users including at least one of a predefinable timing mark and an ascertainable timing mark, comprising: 20

- a transmitting arrangement for causing the at least two users to transmit via the bus system messages including the data; 25
- a controlling arrangement for causing a first one of the at least two users, in a function as timer, to control the messages as a function of time such that the first one of the at least two users repeatedly transmits a first reference message including a first time information regarding a time base of the first one of the at least two users, via the bus system at a specifiable time interval; and 30
- a second transmitting arrangement for causing, if the at least one of the predefinable timing mark and the ascertainable timing mark of a second one of the at least two users is reached without the first reference message of the first one of the at least two users reaching the second one of the at least two users, the second one of the at least two users to take over the function of timer by transmitting a second reference message with a second time information regarding a time base of the second one of the at least two users, via the bus system, wherein one of the first time information and the second time information is used by a receiving user to calculate a global time as a function of a local time information and the one of the first time information and the second time information. 35

7. The device according to claim 6, further comprising: 40

- a providing arrangement for providing each one of the at least two users as timers; 50

wherein the first one of the at least two users and the second one of the at least two users to transmit via the bus system the first reference message with the first time

10

information and the second reference message with the second time information when the at least one of the predefinable timing mark and the ascertainable timing mark of any of the at least two users has been reached without a receipt of a corresponding one of the first reference message and the second reference message.

8. The device according to claim 6, wherein the specifiable time interval is subdivided into timing windows of a specifiable length, and wherein the messages including the data are transmitted in the timing windows.

9. The device according to claim 8, wherein the messages are cyclically transmitted.

10. The device according to claim 6, wherein a priority with respect to the function as timer is allocated to those of the at least two users that are used as a timer. 15

11. The device according to claim 6, further comprising: a providing arrangement for providing each one of the at least two users as timers; 20

- wherein the first one of the at least two users and the second one of the at least two users to transmit via the bus system the first reference message with the first time information and the second reference message with the second time information when the at least one of the predefinable timing mark and the ascertainable timing mark of any of the at least two users has been reached without a receipt of a corresponding one of the first reference message and the second reference message; 25
- wherein a priority with respect to the function as timer is allocated to those of the at least two users that are used as a timer, 30
- wherein the specifiable time interval is subdivided into timing windows of a specifiable length, 35
- wherein the messages including the data are transmitted in the timing windows, and 40
- wherein the messages are cyclically transmitted. 45

12. The method according to claim 1, further comprising: providing each one of the at least two users as timers; 50

- causing the first one of the at least two users and the second one of the at least two users to transmit via the bus system the first reference message with the first time information and the second reference message with the second time information when the at least one of the predefinable timing mark and the ascertainable timing mark of any of the at least two users has been reached without a receipt of a corresponding one of the first reference message and the second reference message; 55
- allocating a priority with respect to the function as timer to those of the at least two users that are used as a timer; 60
- subdividing the specifiable time interval into timing windows of a specifiable length; and 65
- transmitting the messages including the data in the timing windows; 70
- wherein the messages are cyclically transmitted. 75

\* \* \* \* \*