



US00RE49205E

(19) **United States**
(12) **Reissued Patent**
Johnson et al.

(10) **Patent Number:** **US RE49,205 E**
(45) **Date of Reissued Patent:** **Sep. 6, 2022**

(54) **JOHNSON LITHIUM OXYGEN ELECTROCHEMICAL ENGINE**

(58) **Field of Classification Search**
None

(71) Applicant: **Johnson IP Holding, LLC**, Atlanta, GA (US)

See application file for complete search history.

(72) Inventors: **Lonnie G. Johnson**, Atlanta, GA (US);
Tedric D. Campbell, Lithia Springs, GA (US)

(56) **References Cited**

U.S. PATENT DOCUMENTS

3,237,078 A 2/1966 Mallory
3,393,355 A 7/1968 Whoriskey et al.
(Continued)

(73) Assignee: **JOHNSON IP HOLDING, LLC**, Atlanta, GA (US)

FOREIGN PATENT DOCUMENTS

(21) Appl. No.: **16/437,141**

CN 1866583 A 11/2006
CN 101434417 A 5/2009

(22) Filed: **Jun. 11, 2019**

(Continued)

Related U.S. Patent Documents

Reissue of:

(64) Patent No.: **10,218,044**
Issued: **Feb. 26, 2019**
Appl. No.: **15/408,991**
Filed: **Jan. 18, 2017**

OTHER PUBLICATIONS

Office Action dated Dec. 17, 2020 in CN Application No. 201780007783.8.

(Continued)

U.S. Applications:

(60) Provisional application No. 62/281,875, filed on Jan. 22, 2016.

Primary Examiner — Sean E Vincent

(74) *Attorney, Agent, or Firm* — Panitch Schwarze Belisario & Nadel LLP

(51) **Int. Cl.**
H01M 12/08 (2006.01)
H01M 8/04276 (2016.01)
(Continued)

(57) **ABSTRACT**

A rechargeable lithium air battery is provided. The battery contains a ceramic separator forming an anode chamber, a molten lithium anode contained in the anode chamber, an air cathode, and a non-aqueous electrolyte. The cathode has a temperature gradient comprising a low temperature region and a high temperature region, and the temperature gradient provides a flow system for reaction product produced by the battery.

(52) **U.S. Cl.**
CPC **H01M 12/08** (2013.01); **H01M 4/134** (2013.01); **H01M 4/382** (2013.01); **H01M 4/8621** (2013.01); **H01M 8/04276** (2013.01); **H01M 10/0562** (2013.01); **H01M 10/0563** (2013.01); **H01M 10/399** (2013.01); **H01M 10/615** (2015.04); **H01M 10/617** (2015.04); **H01M 10/63** (2015.04); **H01M 10/652** (2015.04); **H01M 10/654** (2015.04);
(Continued)

41 Claims, 8 Drawing Sheets

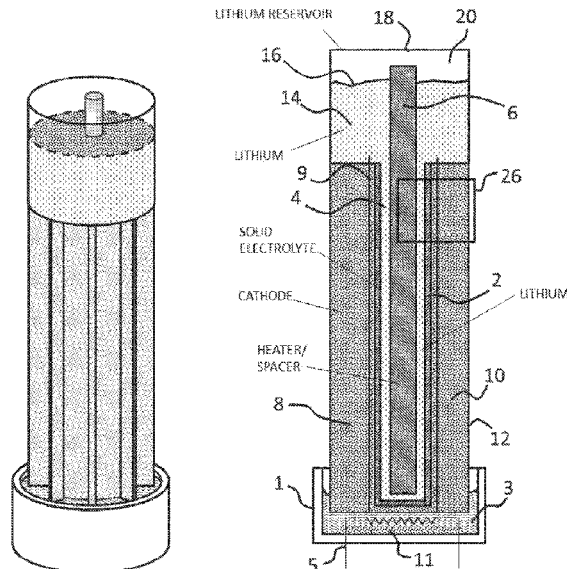

(51)	Int. Cl.		5,474,959 A	12/1995	Schafer et al.
	<i>H01M 12/02</i>	(2006.01)	5,512,147 A	4/1996	Bates et al.
	<i>H01M 10/652</i>	(2014.01)	5,522,955 A	6/1996	Brodd
	<i>H01M 10/617</i>	(2014.01)	5,561,004 A	10/1996	Bates et al.
	<i>H01M 10/654</i>	(2014.01)	5,567,210 A	10/1996	Bates et al.
	<i>H01M 4/86</i>	(2006.01)	5,569,520 A	10/1996	Bates
	<i>H01M 10/615</i>	(2014.01)	5,597,660 A	1/1997	Bates et al.
	<i>H01M 4/38</i>	(2006.01)	5,612,152 A	3/1997	Bates
	<i>H01M 10/655</i>	(2014.01)	5,654,084 A	8/1997	Egert
	<i>H01M 10/0569</i>	(2010.01)	5,677,081 A	10/1997	Iwamoto et al.
	<i>H01M 10/48</i>	(2006.01)	5,705,293 A	1/1998	Hobson
	<i>H01M 50/431</i>	(2021.01)	5,778,515 A	7/1998	Menon
	<i>H01M 50/434</i>	(2021.01)	5,783,333 A	7/1998	Mayer
	<i>H01M 50/437</i>	(2021.01)	5,783,928 A	7/1998	Okamura
	<i>H01M 10/6551</i>	(2014.01)	5,811,205 A	9/1998	Andrieu et al.
	<i>H01M 10/6571</i>	(2014.01)	5,821,733 A	10/1998	Turnbull
	<i>H01M 10/39</i>	(2006.01)	6,022,642 A	2/2000	Tsukamoto et al.
	<i>H01M 10/0562</i>	(2010.01)	6,136,472 A	10/2000	Barker et al.
	<i>H01M 4/134</i>	(2010.01)	6,139,986 A	10/2000	Kurokawa et al.
	<i>H01M 10/63</i>	(2014.01)	6,168,884 B1	1/2001	Neudecker et al.
	<i>H01M 10/0563</i>	(2010.01)	6,182,340 B1	2/2001	Bishop
	<i>H01M 4/02</i>	(2006.01)	6,201,123 B1	3/2001	Daikai et al.
(52)	U.S. Cl.		6,242,129 B1	6/2001	Johnson
	CPC		6,255,122 B1	7/2001	Duncombe et al.
	<i>H01M 10/655</i> (2015.04); <i>H01M 10/6551</i>		6,387,563 B1	5/2002	Bates
	(2015.04); <i>H01M 10/6571</i> (2015.04); <i>H01M</i>		6,413,285 B1	7/2002	Chu et al.
	<i>12/02</i> (2013.01); <i>H01M 50/431</i> (2021.01);		6,413,672 B1	7/2002	Suzuki et al.
	<i>H01M 50/434</i> (2021.01); <i>H01M 50/437</i>		6,541,161 B1	4/2003	Scanlon, Jr.
	(2021.01); <i>H01M 10/0569</i> (2013.01); <i>H01M</i>		6,679,926 B1	1/2004	Kajiura et al.
	<i>10/486</i> (2013.01); <i>H01M 2004/027</i> (2013.01);		6,827,921 B1	12/2004	Singhal et al.
	<i>H01M 2004/8689</i> (2013.01); <i>H01M 2300/0048</i>		6,852,139 B2	2/2005	Zhang et al.
	(2013.01); <i>H01M 2300/0068</i> (2013.01); <i>Y02E</i>		6,886,240 B2	5/2005	Zhang et al.
	<i>60/10</i> (2013.01); <i>Y02E 60/50</i> (2013.01)		6,887,612 B2	5/2005	Bitterlich et al.
			7,230,404 B2	6/2007	Kimoto et al.
			7,276,308 B2	10/2007	Formanski et al.
			7,510,800 B2	3/2009	Yoshida et al.
			7,524,580 B1	4/2009	Birke et al.
			7,540,886 B2	6/2009	Zhang et al.
			7,557,055 B2	7/2009	Zhang et al.
			7,674,559 B2	3/2010	Min et al.
			7,691,536 B2	4/2010	Johnson
			7,732,096 B2	6/2010	Thackeray et al.
			7,776,478 B2	8/2010	Klaassen
			7,824,795 B2	11/2010	Yoshida et al.
			7,901,658 B2	3/2011	Weppner et al.
			7,914,932 B2	3/2011	Yoshida et al.
			7,998,622 B2	8/2011	Inda
			8,092,941 B2	1/2012	Weppner et al.
			8,173,292 B2	5/2012	Kato
			8,192,869 B2	6/2012	Teramoto
			8,211,496 B2	7/2012	Johnson et al.
			8,221,916 B2	7/2012	Inda
			8,313,721 B2	11/2012	Thackeray et al.
			8,383,268 B2	2/2013	Inda
			8,431,287 B2	4/2013	Teramoto
			8,476,174 B2	7/2013	Inda
			8,568,921 B1	10/2013	Johnson
			8,778,546 B2	7/2014	Farmer
			8,795,868 B1	8/2014	Miles
			8,808,407 B2	8/2014	Inda
			8,822,077 B2	9/2014	Katoh
			8,852,816 B2	10/2014	Ogasa
			8,883,355 B2	11/2014	Inda
			8,951,681 B2	2/2015	Katoh
			9,034,525 B2	5/2015	Babic et al.
			9,153,838 B2	10/2015	Ogasa
			9,159,989 B2	10/2015	Ogasa
			9,178,255 B2	11/2015	Kumar et al.
			9,203,123 B2	12/2015	Prochazka, Jr. et al.
			9,263,770 B2	2/2016	Boxley et al.
			9,266,780 B2	2/2016	Ogasa
			9,379,375 B2	6/2016	Sugiura et al.
			9,385,405 B2	7/2016	Murata et al.
			9,413,033 B2	8/2016	Ogasa
			9,413,036 B2	8/2016	Bhavaraju et al.
			9,425,454 B2	8/2016	Sugiura et al.
			9,450,278 B2	9/2016	Kim et al.
			9,680,191 B2	6/2017	Lee et al.
			9,711,822 B2	7/2017	Nakashima et al.
(56)	References Cited				
	U.S. PATENT DOCUMENTS				
	4,299,682 A	11/1981	Oda et al.		
	4,303,877 A	12/1981	Meinhold		
	4,352,068 A	9/1982	Weppner		
	4,386,020 A	5/1983	Hartwig et al.		
	4,419,421 A	12/1983	Wichelhaus et al.		
	4,495,078 A	1/1985	Bell et al.		
	4,513,069 A	4/1985	Kreuer et al.		
	4,526,855 A	7/1985	Hartwig et al.		
	4,614,905 A	9/1986	Petersson et al.		
	4,654,281 A	3/1987	Anderman et al.		
	4,704,341 A	11/1987	Weppner et al.		
	4,710,848 A	12/1987	Schlechtriemen et al.		
	4,719,401 A	1/1988	Altmejd		
	4,728,590 A	3/1988	Redey		
	4,777,119 A	10/1988	Brault et al.		
	4,792,752 A	12/1988	Schlechtriemen et al.		
	4,803,134 A	2/1989	Sammells		
	4,885,267 A	12/1989	Takahara et al.		
	4,931,214 A	6/1990	Worrell et al.		
	5,023,153 A	6/1991	Weppner		
	5,202,788 A	4/1993	Weppner		
	5,238,761 A	8/1993	Ryan		
	5,260,821 A	11/1993	Chu et al.		
	5,270,635 A	12/1993	Hoffman et al.		
	5,291,116 A	3/1994	Feldstein		
	5,314,765 A	5/1994	Bates		
	5,322,601 A	6/1994	Liu et al.		
	5,336,573 A	8/1994	Zuckerbrod et al.		
	5,338,625 A	8/1994	Bates et al.		
	5,362,581 A	11/1994	Chang et al.		
	5,387,857 A	2/1995	Honda et al.		
	5,411,592 A	5/1995	Ovshinsky et al.		
	5,432,026 A	7/1995	Sahm et al.		
	5,445,906 A	8/1995	Hobson et al.		
	5,455,126 A	10/1995	Bates et al.		

(56)

References Cited

U.S. PATENT DOCUMENTS

9,917,304 B2 3/2018 Lee et al.
 9,954,260 B2 4/2018 Ho
 9,997,813 B2 6/2018 Park et al.
 10,566,611 B2 2/2020 Allie et al.
 10,686,224 B2 6/2020 Angell et al.
 10,693,170 B2 6/2020 Jin et al.
 10,734,686 B2 8/2020 Robins et al.
 10,797,340 B2 10/2020 Lee et al.
 2001/0014505 A1 8/2001 Duncombe et al.
 2001/0036578 A1 11/2001 Nishida et al.
 2002/0000541 A1 1/2002 Sasaki et al.
 2002/0008706 A1 4/2002 Mayes et al.
 2002/0119375 A1 8/2002 Zhang
 2003/0012996 A1 1/2003 Bitterlich et al.
 2003/0030039 A1 2/2003 Sasaki et al.
 2003/0118897 A1 6/2003 Mino et al.
 2003/0157407 A1 8/2003 Kosuzu et al.
 2004/0081888 A1 4/2004 Thackeray et al.
 2004/0101761 A1 5/2004 Park et al.
 2004/0111874 A1 6/2004 Schierle-Arndt et al.
 2004/0118700 A1 6/2004 Schierle-Arndt et al.
 2004/0151986 A1 8/2004 Park et al.
 2004/0191617 A1 9/2004 Visco et al.
 2005/0084758 A1 4/2005 Yamamoto et al.
 2005/0095506 A1 5/2005 Klaassen
 2005/0100793 A1 5/2005 Jonghe et al.
 2005/0147890 A1 7/2005 Shembel et al.
 2005/0266150 A1 12/2005 Yong et al.
 2006/0046149 A1 3/2006 Yong et al.
 2006/0068282 A1 3/2006 Kishi et al.
 2006/0093916 A1 5/2006 Howard et al.
 2006/0165578 A1 7/2006 Sasaki et al.
 2006/0246355 A1 11/2006 Min et al.
 2006/0287188 A1 12/2006 Borland et al.
 2007/0031323 A1 2/2007 Baik et al.
 2007/0048617 A1 3/2007 Inda
 2007/0087269 A1 4/2007 Inda
 2007/0148545 A1 6/2007 Amine et al.
 2007/0148553 A1 6/2007 Weppner
 2007/0231704 A1 10/2007 Inda
 2007/0264579 A1 11/2007 Ota
 2008/0131781 A1 6/2008 Yong et al.
 2008/0220334 A1 9/2008 Inda
 2008/0241698 A1 10/2008 Katoh
 2008/0268346 A1 10/2008 Inda
 2009/0004371 A1 1/2009 Johnson et al.
 2009/0068563 A1 3/2009 Kanda et al.
 2009/0081554 A1 3/2009 Takada et al.
 2009/0081555 A1 3/2009 Teramoto
 2009/0092903 A1 4/2009 Johnson et al.
 2009/0098281 A1 4/2009 Zhang et al.
 2009/0142669 A1 6/2009 Shinohara et al.
 2009/0162755 A1 6/2009 Neudecker
 2009/0194222 A1 8/2009 Teramoto
 2009/0197178 A1 8/2009 Inda
 2009/0197182 A1 8/2009 Katoh
 2009/0214957 A1 8/2009 Okada et al.
 2009/0274832 A1 11/2009 Inda
 2010/0028782 A1 2/2010 Inda
 2010/0047696 A1 2/2010 Yoshida et al.
 2010/0104948 A1 4/2010 Skotheim et al.
 2010/0203383 A1 8/2010 Weppner
 2010/0291443 A1 11/2010 Farmer
 2010/0308278 A1 12/2010 Kepler et al.
 2011/0053001 A1 3/2011 Babic et al.
 2011/0059369 A1 3/2011 Nan et al.
 2011/0076542 A1 3/2011 Farmer
 2011/0086274 A1 4/2011 Chang et al.
 2011/0133136 A1 6/2011 Weppner et al.
 2011/0177397 A1 7/2011 Ogasa
 2011/0209859 A1 9/2011 Reinke et al.
 2011/0223460 A1 9/2011 Farmer
 2011/0223467 A1 9/2011 Shacklette et al.
 2011/0223487 A1 9/2011 Johnson et al.
 2011/0300451 A1 12/2011 Inda

2011/0318650 A1 12/2011 Zhang et al.
 2012/0100433 A1 4/2012 Suyama et al.
 2012/0141881 A1 6/2012 Geier et al.
 2012/0196189 A1 8/2012 Babic et al.
 2012/0237834 A1 9/2012 Ogasa
 2012/0251882 A1 10/2012 Moon et al.
 2012/0264021 A1 10/2012 Sugiura et al.
 2012/0270115 A1 10/2012 Johnson
 2013/0011751 A1 1/2013 Nakada et al.
 2013/0011752 A1 1/2013 Tanaami et al.
 2013/0017454 A1 1/2013 Sato et al.
 2013/0095394 A1 4/2013 Tanaami et al.
 2013/0157149 A1* 6/2013 Peled H01M 4/38
 429/405
 2013/0164616 A1 6/2013 Nakada et al.
 2013/0230777 A1 9/2013 Babic et al.
 2013/0273437 A1 10/2013 Yoshioka et al.
 2013/0309551 A1 11/2013 Ogasa
 2013/0344416 A1 12/2013 Sakamoto et al.
 2014/0008006 A1 1/2014 Lee et al.
 2014/0011080 A1 1/2014 Lee et al.
 2014/0011095 A1 1/2014 Lee et al.
 2014/0023933 A1 1/2014 Chiga et al.
 2014/0038058 A1 2/2014 Holzapfel et al.
 2014/0065456 A1* 3/2014 Bhavaraju H01M 10/36
 429/81
 2014/0099538 A1 4/2014 Johnson et al.
 2014/0099556 A1 4/2014 Johnson et al.
 2014/0287305 A1 9/2014 Wachsmann et al.
 2015/0037688 A1 2/2015 Otsuka et al.
 2015/0056518 A1 2/2015 Babic et al.
 2015/0056520 A1 2/2015 Thokchom et al.
 2015/0099187 A1 4/2015 Cui et al.
 2015/0099197 A1 4/2015 Nakashima et al.
 2015/0333307 A1 11/2015 Thokchom et al.
 2016/0028133 A1 1/2016 Miles
 2016/0036109 A1 2/2016 Kim et al.
 2016/0149261 A1 5/2016 Zaghib et al.
 2016/0164153 A1 6/2016 Kim et al.
 2016/0181657 A1 6/2016 Kawaji et al.
 2016/0329539 A1 11/2016 Kawaji et al.
 2016/0336583 A1 11/2016 Smith et al.
 2017/0179521 A1* 6/2017 Sakamoto H01M 10/0562
 2017/0214106 A1 7/2017 Johnson et al.
 2017/0222287 A1 8/2017 Suzuki et al.
 2019/0296276 A1 9/2019 Bradwell et al.
 2019/0372148 A1 12/2019 He et al.
 2021/0218091 A1 7/2021 Uddin et al.
 2021/0265616 A1 8/2021 Kim et al.

FOREIGN PATENT DOCUMENTS

CN 101494299 A 7/2009
 CN 102214827 A 10/2011
 CN 102013536 B 10/2012
 CN 102934279 A 2/2013
 CN 104245624 A 12/2014
 CN 206048735 U 3/2017
 CN 107437636 A 12/2017
 CN 206921981 U 1/2018
 CN 207413450 U 5/2018
 DE 4309070 A1 9/1994
 DE 102004010892 B3 11/2005
 DE 102007030604 A1 1/2009
 DE 102010019187 A1 11/2011
 DE 102015220354 A1 4/2017
 EP 0070020 A1 1/1983
 EP 0033935 B1 8/1985
 EP 0177062 A2 4/1986
 EP 0190605 A2 8/1986
 EP 0206339 A2 12/1986
 EP 0226955 A2 7/1987
 EP 0232513 A2 8/1987
 EP 0243975 A2 11/1987
 EP 0249802 A2 12/1987
 EP 238383 B1 8/1989
 EP 0408039 A2 1/1991
 EP 0227996 B1 7/1991
 EP 0470597 A2 2/1992

(56)

References Cited

FOREIGN PATENT DOCUMENTS

- | | | | |
|----|-------------|----|---------|
| EP | 0693581 | B1 | 5/1998 |
| EP | 1271683 | A2 | 1/2003 |
| EP | 1431422 | A1 | 6/2004 |
| EP | 1431423 | A1 | 6/2004 |
| EP | 1237212 | A3 | 4/2005 |
| EP | 2037527 | A1 | 3/2009 |
| EP | 2086040 | A2 | 8/2009 |
| EP | 2181971 | A1 | 5/2010 |
| EP | 2685551 | A1 | 1/2014 |
| EP | 2706598 | A1 | 3/2014 |
| EP | 2903060 | A1 | 8/2015 |
| FR | 2466107 | A1 | 3/1981 |
| GB | 1329688 | A | 9/1973 |
| GB | 1599792 | A | 10/1981 |
| GB | 2226441 | B | 12/1992 |
| JP | S628452 | A | 1/1987 |
| JP | H05-310417 | A | 11/1993 |
| JP | H07235291 | A | 9/1995 |
| JP | 2000311710 | A | 11/2000 |
| JP | 2000331680 | A | 11/2000 |
| JP | 2000331684 | A | 11/2000 |
| JP | 2001126757 | A | 5/2001 |
| JP | 2001126758 | A | 5/2001 |
| JP | 2001243954 | A | 9/2001 |
| JP | 2003132921 | A | 5/2003 |
| JP | 2004127613 | A | 4/2004 |
| JP | 2006260887 | A | 9/2006 |
| JP | 2006261008 | A | 9/2006 |
| JP | 2006310295 | A | 11/2006 |
| JP | 2008505458 | A | 2/2008 |
| JP | 2009176741 | A | 8/2009 |
| JP | 2010067499 | A | 3/2010 |
| JP | 2010080426 | A | 4/2010 |
| JP | 2010129190 | A | 6/2010 |
| JP | 2010132533 | A | 6/2010 |
| JP | 2010244729 | A | 10/2010 |
| JP | 2011134675 | A | 7/2011 |
| JP | 2011150817 | A | 8/2011 |
| JP | 2011249254 | A | 12/2011 |
| JP | 2012003940 | A | 1/2012 |
| JP | 2012099315 | A | 5/2012 |
| JP | 2012146479 | A | 8/2012 |
| JP | 2013037992 | A | 2/2013 |
| JP | 2013157084 | A | 8/2013 |
| JP | 2013532359 | A | 8/2013 |
| JP | 2015013775 | A | 1/2015 |
| JP | 2015138741 | A | 7/2015 |
| JP | 2015144061 | A | 8/2015 |
| JP | 2015204215 | A | 11/2015 |
| JP | 2015230801 | A | 12/2015 |
| KR | 20140006046 | A | 1/2014 |
| RU | 2126192 | C1 | 2/1999 |
| WO | 2005085138 | A1 | 9/2005 |
| WO | 2006005066 | A2 | 1/2006 |
| WO | 2006019245 | A1 | 2/2006 |
| WO | 2007004590 | A1 | 1/2007 |
| WO | 2007075867 | A2 | 7/2007 |
| WO | 2009003695 | A2 | 1/2009 |
| WO | 2009029746 | A1 | 3/2009 |
| WO | 2011007445 | A1 | 1/2011 |
| WO | 2011125481 | A1 | 10/2011 |
| WO | 2011150528 | A1 | 12/2011 |
| WO | 2011154869 | A2 | 12/2011 |
| WO | 2011156392 | A1 | 12/2011 |
| WO | 2012008422 | A1 | 1/2012 |
| WO | 2012016606 | A1 | 2/2012 |
| WO | 2012018831 | A1 | 2/2012 |
| WO | 2012128374 | A1 | 9/2012 |
| WO | 2012144553 | A1 | 10/2012 |
| WO | 2013049460 | A1 | 4/2013 |
| WO | 2013085557 | A1 | 6/2013 |
| WO | 2013130983 | A2 | 9/2013 |
| WO | 2013131005 | A2 | 9/2013 |
| WO | 2014058683 | A1 | 4/2014 |
| WO | 2014058684 | A2 | 4/2014 |
| WO | 2015007680 | A1 | 1/2015 |
| WO | 2015104538 | A1 | 7/2015 |
| WO | 2015128982 | A1 | 9/2015 |
| WO | 2015151144 | A1 | 10/2015 |
| WO | 2016102373 | A1 | 6/2016 |
| WO | 2016116400 | A1 | 7/2016 |
| WO | 2016141765 | A1 | 9/2016 |
| WO | 2020225313 | A1 | 11/2020 |

OTHER PUBLICATIONS

Extended European Search Report dated Feb. 12, 2020 in EP Application No. 19192837.3.

Kim et al., "A review of lithium and non-lithium based solid state batteries," *Journal of Power Sources*, vol. 282, pp. 299-322 (2015). Office Action dated Jun. 7, 2018 in U.S. Appl. No. 15/408,991, by Johnson.

Office Action dated Jun. 10, 2019 in JP Application No. 2018538203 (Partial English Translation).

"All-Solid-State Lithium-Ion Battery Using Li₂C₂O₈B₂O₃ 203 Electrolyte" External Program 20th Century International Conference, Presented on Poster Board, 2 pgs (Jun. 15, 2015).

Aaltonen et al., "Lithium Lanthanum Titanate Thin Films Grown by Atomic Layer Deposition for All-Solid-State Lithium Ion Battery Applications," Abstract #688, The 15th International Meeting on Lithium Batteries (2010).

Adachi et al., "Ionic Conducting Lanthanide Oxides," *Chem. Rev.*, vol. 102, pp. 2405-2429 (2002).

Ahn et al., "Characteristics of Amorphous Lithium Lanthanum Titanate Electrolyte Thin Films Grown by PLD for Use in Rechargeable Lithium Microbatteries," *Electrochemical and Solid-State Letters*, vol. 8, No. 2, pp. A75-A78 (2005).

Ahn et al., "Characteristics of Perovskite (Li_{0.5}La_{0.5})TiO₃ Solid Electrolyte Thin Films Grown by Pulsed Laser Deposition for Rechargeable Lithium Microbattery," *Electrochimica Acta*, vol. 50, pp. 371-374 (2004).

Ahn et al., "Effect of Li_{0.5}La_{0.5}TiO₃ Solid Electrolyte Films on Electrochemical Properties of LiCoO₂ Thin Film Cathodes with Different Rapid-Thermal Annealing Conditions," *Journal of Vacuum Science & Technology B*, vol. 23, No. 5, pp. 2089-2094 (2005).

Allen et al., "Effect of substitution (Ta, Al, Ga) on the conductivity of Li₇La₃Zr₂O₁₂," *Journal of Power Sources*, vol. 206, pp. 315-319(2012).

Allnatt et al., "Atomic Transport in Solids," Cambridge University Press, pp. ix-xiii (2003).

Annamareddy et al., "Ion Hopping and Constrained Li Diffusion Pathways in the Superionic State of Antifluorite Li₂O," *Entropy*, vol. 19, No. 227, pp. 1-11 (2017).

Aruna et al., "Combustion Synthesis and Nanomaterials," *Current Opinion in Solid State and Materials Science*, vol. 12, pp. 44-50 (2008).

Awaka et al., "Synthesis and Structure Analysis of Tetragonal Li₇La₃Zr₂O₁₂ with the Garnet-Related Type Structure," *Journal of Solid State Chemistry*, vol. 182, No. 8, pp. 2046-2052 (2009).

Balkanski et al., "Integrable lithium solid-state microbatteries," *Journal of Power Sources*, vol. 26, pp. 615-622 (1989).

Bates et al., "Rechargeable Thin-Film Lithium Batteries," Oak Ridge National Laboratory Publication, 9 pgs (1993).

Billinge, "The Nanostructure Problem," *Physics*, vol. 3, No. 25, pp. 1-3 (2010).

Birke et al., "A first approach to a monolithic all solid state inorganic lithium battery," *Solid State Ionics*, vol. 118, pp. 149-157 (1999).

Birke et al., "Electrolytic Stability Limit and Rapid Lithium Insertion in the Fast-Ion-Conducting Li_{0.29}La_{0.57}TiO₃ Perovskite-Type Compound," *Journal of the Electrochemical Society*, vol. 144, No. 6, pp. L167-L169 (1997).

Bohnke et al., "Mechanism of Ionic Conduction and Electrochemical Intercalation of Lithium into the Perovskite Lanthanum Lithium Titanate," *Solid State Ionics*, vol. 91, pp. 21-31 (1996).

Boyd, "Thin Film Growth by Pulsed Laser Deposition," *Ceramics International*, vol. 22, pp. 429-434 (1996).

Boyle et al., "All-Ceramic Thin Film Battery," Sandia Report 2002-3615 Unlimited Release, 53 pages (Nov. 2002).

(56)

References Cited

OTHER PUBLICATIONS

- Brenier, "Stress and Moisture-Sorption in Ozone-Annealed Films of Zirconium Oxide Obtained from Sol-Gel," *Journal of Sol-Gel Science and Technology*, vol. 25, pp. 57-63 (2002).
- Brinker et al., "Sol-Gel Science: The Physics and Chemistry of Sol-Gel Processing," Academic Press, pp. 21, 95, 153, 513, 675, 742, 787, and 837 (1990).
- Buschmann et al., "Structure and dynamics of the fast lithium ion conductor $\text{Li}_7\text{La}_3\text{Zr}_{20}\text{I}_{12}$," *Physical Chemistry Chemical Physics*, vol. 13, p. 19378-19392 (2011) (Abstract Only).
- Cao et al., "Microstructure and Ionic Conductivity of Sb-doped $\text{Li}_7\text{La}_3\text{Zr}_{20}\text{I}_{12}$," *Journal of Inorganic Materials*, vol. 29, No. 2, pp. 220-224 (2014).
- Chabal et al., "Safer High-performance Electrodes, Solid Electrolytes, and Interface Reactions for Lithium-Ion Batteries," *Material Matters*, vol. 8, No. 4, pp. 104-110 (2013).
- Chen et al., "High Capacity and Cyclic Performance in a Three-Dimensional Composite Electrode Filled with Inorganic Solid Electrolyte," *Journal of Power Sources*, vol. 249, pp. 306-310 (2014).
- Chen et al., "Improving ionic conductivity of $\text{Li}_0.35\text{La}_0.55\text{Ti}_0.3$ ceramics by introducing $\text{Li}_7\text{La}_3\text{Zr}_{20}\text{I}_{12}$ sol into the precursor powder," *Solid State Ionics*, vol. 235, pp. 8-13 (2013).
- Cussen, "Structure and Ionic Conductivity in Lithium Garnets," *Journal of Materials Chemistry*, vol. 20, pp. 5167-5173 (2010).
- Davison et al., "Low Cost, Novel Methods for Fabricating All-Solid-State Lithium Ion Batteries," downloaded from web page: <http://www.wpi.edu/Pubs/E-project/Available/E-project-042312-141301/unrestricted/SS_Lithium_Ion_Battery_MQP_Final_Report.pdf>, Download date: Apr. 23, 2012, original posting date unknown, 126 pages.
- Decision to Grant dated Nov. 24, 2020 in KR Application No. 1020187020835.
- Drabold, "Topics in the Theory of Amorphous Materials," *The European Physical Journal B*, vol. 68, pp. 1-21 (2009).
- Elliott, "Physics of Amorphous Materials," Longman Scientific & Technical, Ed. 2, pp. v-vi (1990).
- Examination Report dated Jun. 22, 2016 in EP Application No. 13776685.3.
- Examination Report dated Nov. 30, 2016 in EP Application No. 13776685.3.
- Extended European Search Report dated Feb. 8, 2017 in EP Application 16202541.
- Extended European Search Report dated Mar. 16, 2017 in EP Application No. 17150717.
- Furusawa et al., "Ionic Conductivity of Amorphous Lithium Lanthanum Titanate Thin Film," *Solid State Ionics*, vol. 176, pp. 553-558 (2005).
- Gao et al., "Sol-gel Synthesis and Electrical Properties of $\text{Li}_5\text{La}_3\text{Ta}_2\text{O}_{12}$ Lithium Ionic Conductors," *Solid State Ionics*, vol. 181, Nos. 1-2, pp. 33-36 (2009).
- Geiger et al., "Crystal Chemistry and Stability of $\text{Li}_7\text{La}_3\text{Zr}_{20}\text{I}_{12}$ Garnet: A Fast Lithium-Ion Conductor," *Inorganic Chemistry*, vol. 50, pp. 1089-1097 (2011).
- Giordani et al., "A Molten Salt Lithium-Oxygen Battery," *Journal of the American Chemical Society*, 26 pages (2016).
- Glass et al., "Ionic Conductivity of Quenched Alkali Niobate and Tantalate Glasses," *Journal of Applied Physics*, vol. 19, No. 9, pp. 4808-4811 (1978).
- Goodenough et al., "Challenges for Rechargeable Li Batteries," *Chemistry of Materials*, vol. 22, No. 3, pp. 587-603 (2010).
- Hámáláinen et al., "Lithium Phosphate Thin Films Grown by Atomic Layer Deposition," *Journal of The Electrochemical Society*, vol. 159, No. 3, pp. A259-A263 (2012).
- Huggins, "Advanced Batteries: Materials Science Aspects," Springer, Ed. 1, p. xvii-xxx and pp. 368-371 (2008).
- Inaguma et al., "High Ionic Conductivity in Lithium Lanthanum Titanate," *Solid State Communications*, vol. 86, No. 10, pp. 689-693 (1993).
- Int'l Preliminary Examination Report on Patentability dated Jul. 5, 2018 in Int'l Application No. PCT/US2016/068105.
- Int'l Preliminary Report on Patentability dated Feb. 14, 2013 in Int'l Application No. PCT/US2011/046289.
- Int'l Preliminary Report on Patentability dated Apr. 23, 2015 in Int'l Application No. PCT/US2013/063160.
- Int'l Preliminary Report on Patentability dated Sep. 2, 2014 in Int'l Application No. PCT/US2013/028672.
- Int'l Preliminary Report on Patentability dated Sep. 12, 2014 in Int'l Application No. PCT/US2013/028633.
- Extended European Search Report dated Dec. 16, 2021 in EP Application No. 21186896.3.
- Office Action dated Feb. 9, 2022 in EP Application No. 16823507.5.
- Office Action dated Jan. 22, 2016 in EP Application No. 13776685.3.
- Office Action dated Jan. 24, 2012 in U.S. Appl. No. 12/198,421 by Johnson.
- Office Action dated Jan. 25, 2018 in CN Application No. 201380052598.2.
- Office Action dated Jan. 31, 2019 in U.S. Appl. No. 15/387,143, by Allie.
- Office Action dated Feb. 7, 2018 in U.S. Appl. No. 14/382,194, by Thokchom.
- Office Action dated Feb. 10, 2016 in U.S. Appl. No. 13/829,525 by Johnson.
- Office Action dated Feb. 15, 2017 in CN Application No. 201380052598.2.
- Office Action dated Feb. 20, 2017 in JP Application No. 2014-560097.
- Office Action dated Feb. 21, 2020 in KR Application No. 1020187020835.
- Office Action dated Mar. 2, 2016 in CN Application No. 201380023413.5.
- Office Action dated Mar. 14, 2018 in U.S. Appl. No. 13/829,525, by Johnson.
- Office Action dated Mar. 17, 2020 in U.S. Appl. No. 16/109,295, by Johnson.
- Office Action dated Mar. 26, 2021 in CN Application No. 201680075318.3.
- Office Action dated Mar. 30, 2018 in CN Application No. 201380023413.5.
- Office Action dated Apr. 9, 2015 in U.S. Appl. No. 13/829,525 by Johnson.
- Office Action dated Apr. 10, 2018 in EP Application No. 16202541.5.
- Office Action dated Apr. 29, 2014 in U.S. Appl. No. 12/848,991 by Babic.
- Office Action dated May 1, 2014 in U.S. Appl. No. 13/410,895, by Babic.
- Office Action dated May 4, 2015 in U.S. Appl. No. 13/829,951 by Johnson.
- Office Action dated May 4, 2016 in KR Application No. 10-2014-7027734.
- Office Action dated May 19, 2017 in U.S. Appl. No. 12/198,421, by Johnson.
- Office Action dated May 30, 2017 in JP Application No. 2015-535772.
- Office Action dated Jun. 2, 2016 in CN Application No. 201380052598.2.
- Office Action dated Jun. 5, 2019 in CN Application No. 201380052598.2.
- Office Action dated Jun. 12, 2017 in U.S. Appl. No. 14/382,194, by Thokchom.
- Office Action dated Jun. 13, 2017 in JP Application No. 2015-535773.
- Office Action dated Jun. 15, 2017 in U.S. Appl. No. 14/382,191, by Thokchom.
- Office Action dated Jun. 17, 2019 in U.S. Appl. No. 15/387,143, by Allie.
- Office Action dated Jun. 19, 2014 in U.S. Appl. No. 13/829,951, by Johnson.
- Office Action dated Jun. 24, 2019 in JP Application No. 2018551909.
- Office Action dated Jun. 26, 2015 in U.S. Appl. No. 14/530,171 by Babic.

(56)

References Cited

OTHER PUBLICATIONS

- Office Action dated Jun. 29, 2018 in U.S. Appl. No. 14/382,194, by Thokchom.
- Office Action dated Jul. 1, 2015 in U.S. Appl. No. 13/829,525 by Johnson.
- Office Action dated Jul. 5, 2016 in CN Application No. 201380052635. X.
- Office Action dated Jul. 13, 2011 in U.S. Appl. No. 12/163,044, by Johnson.
- Office Action dated Jul. 15, 2016 in KR Application No. 10-2014-7027734.
- Office Action dated Jul. 20, 2017 in CN Application No. 201380052635. X.
- Office Action dated Jul. 21, 2016 in U.S. Appl. No. 13/829,951, by Johnson.
- Office Action dated Jul. 27, 2016 in U.S. Appl. No. 13/829,525, by Johnson.
- Office Action dated Aug. 3, 2020 in CN Application No. 201680075318. 3.
- Office Action dated Aug. 7, 2017 in U.S. Appl. No. 13/829,525, by Johnson.
- Office Action dated Aug. 7, 2019 in U.S. Appl. No. 12/198,421, by Johnson.
- Office Action dated Aug. 9, 2021 in U.S. Appl. No. 12/198,421, by Johnson.
- Office Action dated Aug. 11, 2017 in CN Application No. 2013800234135.
- Office Action dated Aug. 21, 2020 in U.S. Appl. No. 12/198,421, by Johnson.
- Office Action dated Aug. 22, 2016 in JP Application No. 2014-560097.
- Office Action dated Aug. 30, 2021 in JP Application No. 2020114023.
- Office Action dated Aug. 31, 2015 in KR Application No. 10-2014-7027734.
- Office Action dated Sep. 3, 2018 in CN Application No. 201380052598. 2.
- Office Action dated Sep. 4, 2015 in EP Application No. 13776685.3.
- Office Action dated Sep. 7, 2015 in JP Application No. 2014-560097, translation only.
- Office Action dated Sep. 8, 2015 in U.S. Appl. No. 12/198,421 by Johnson.
- Office Action dated Sep. 10, 2021 in CN Application No. 201910697285.1 (with English Translation of Search Report).
- Office Action dated Sep. 14, 2016 in U.S. Appl. No. 12/198,421, by Johnson.
- Office Action dated Sep. 28, 2020 in JP Application No. 2019173287.
- Office Action dated Nov. 2, 2018 in U.S. Appl. No. 12/198,421, by Johnson.
- Office Action dated Nov. 16, 2021 in CN Application No. 201680075318.3.
- Office Action dated Nov. 18, 2016 in CN Application No. 201380023413.5.
- Office Action dated Nov. 18, 2016 in U.S. Appl. No. 13/829,951, by Johnson.
- Office Action dated Dec. 6, 2013 in U.S. Appl. No. 12/848,991 by Babic.
- Office Action dated Dec. 13, 2018 in CN Application No. 2013800234135.
- Oh et al., "Ionomer Binders Can Improve Discharge Rate Capability in Lithium-Ion Battery Cathodes," *Journal of The Electrochemical Society*, vol. 158, No. 2, pp A207-A213 (2011).
- Ohta et al., "All-solid-state lithium ion battery using garnet-type oxide and Li3BO3 solid electrolytes fabricated by screen-printing," *Journal of Power Sources* (2013).
- Okumura et al., "All-Solid-State Lithium-Ion Battery Using Li2.2C0.8B0.8B0.2O3 Electrolyte," *Solid State Ionic*, vol. 288, pp. 248-252 (2016).
- Owen, "Rechargeable Lithium Batteries," *Chemical Society Reviews*, vol. 26, pp. 259-267 (1997).
- Peters et al., "Ionic Conductivity and Activation Energy for Oxygen Ion Transport in Superlattices - The Multilayer System CSZ (ZrO2 + CaO) / Al2O3," *Solid State Ionics*, vol. 178, Nos. 1-2, pp. 67-76 (2007).
- Pham et al., "Synthesis and Characterization of Nanostructured Fast Ionic Conductor Li0.30La0.56TiO3," *Chemistry of Materials*, vol. 18, No. 18, pp. 4385-4392 (2006).
- Popovici et al., "Sol-gel Preparation and Characterization of Perovskite Lanthanum Lithium Titanate," *Journal of Materials Science*, vol. 42, pp. 3373-3377 (2007).
- Ramzy et al., "Tailor-Made Development of Fast Li Ion Conducting Garnet-Like Solid Electrolytes," *Applied Materials & Interfaces*, vol. 2, No. 2, pp. 385-390 (2010).
- Raskovalov et al., "Structure and transport properties of Li7La3Zr2-0.75xAlxO2 superionic solid electrolytes," *Journal of Power Sources* (2013).
- Rowell et al., "A new class of materials for lithium-ion batteries: iron(III) borates," *Journal of Power Sources*, vol. 98-98, pp. 254-257 (2001).
- Sakamoto, "Lithium Batteries," Michigan State University (2011).
- Sanchez et al., "Chemical Modification of Alkoxide Precursors," *Journal of Non-Crystalline Solids*, vol. 100, pp. 65-76 (1988).
- Scanlon, "Lithium Polymer Battery, Final Report for Dec. 8, 1994-Dec. 30, 2002," Energy Storage and Thermal Sciences Branch, Air Force Research Laboratory (2003).
- Shannon et al., "New Li Solid Electrolytes," *Electro*, vol. 22, No. 7, pp. 783-796 (Jul. 1977).
- Singhal et al., "High Temperature Solid Oxide Fuel Cells: Fundamentals, Design and Applications," Elsevier Advanced Technology, 430 pages (2003).
- Song et al., "Review of Gel-Type Polymer Electrolytes for Lithium-ion Batteries," *Journal of Power Sources*, vol. 77, pp. 183-197 (1999).
- Stramare et al., "Lithium Lanthanum Titanates: A Review," *Chemistry of Materials*, vol. 15, pp. 3974-3990 (2003).
- Sulaiman, "Fabrication and Characterization of LiN03-AI203 Composite Solid Electrolytes," 2013 3rd International Conference on Chemistry and Chemical Engineering, vol. 38, pp. 1-5 (2012).
- Sun et al., "High-Strength All-Solid Lithium Ion Electrodes Based on Li4Ti5O12," *Journal of Power Sources*, vol. 196, pp. 6507-11 (2011).
- Tadnaga et al., "Low temperature synthesis of highly ion conductive Li7La3Zr2O12-Li3B03 composites," *Electrochemistry Communications* (Apr. 3, 2013).
- Tan et al., "Fabrication and Characterization of Li7La3Zr2O12 Thin Films for Lithium Ion Battery," *ECS Solid State Letters*, vol. 1, No. 6, pp. 057-060 (2012).
- Tan et al., "Garnet-type Li7La3Zr2O12 Electrolyte Prepared by a Solution-Based Technique for Lithium ion battery," *Water. Res. Soc. Symp. Proc.*, vol. 1440, 6 pages (2012).
- Fan et al., "Synthesis of Cubic Phase Li7La3Zr2O12 Electrolyte for Solid-State Lithium-Ion Batteries," *Electrochemical and Solid-State Letters*, vol. 15, No. 3, pp. A37-A39 (2012).
- Tan, "Materials for energy storage in Lithium-Ion batteries," Dissertation submitted to the University of Utah (Dec. 2012).
- Thangadurai et al., "Investigations on Electrical Conductivity and Chemical Compatibility Between Fast Lithium Ion Conducting Garnet-Life Li6BaLa2Ta2O12 and Lithium Battery Cathodes," *Journal of Power Sources*, vol. 142, pp. 339-344 (2005).
- Vijayakumar et al., "Synthesis of Fine Powders of Li3xLa2/3-xTiO3 Perovskite by a Polymerizable Precursor Method," *Chemistry of Materials*, vol. 16, No. 14, pp. 2719-2724 (2004).
- Wang et al., "Ionic/Electronic Conducting Characteristics of LiFePO4 Cathode Materials," *Electrochemical and Solid-State Letters*, vol. 10, No. 3, pp. A65-A69 (2007).
- West, "Basic Solid State Chemistry," John Wiley & Sons Ltd., Ed. 2, pp. vii-xv, 346-351 (1999).
- Wohrle et al., "Sol-Gel Synthesis of the Lithium-Ion Conducting Perovskite La0.57Li0.3TiO3 Effect of Synthesis and Thermal Treatments on the Structure and Conducting Properties," *Ionics*, vol. 2, pp. 442-445 (1996).
- Wolfenstine, "Grain Boundary Conductivity in Crystalline LiTi2(PO4)3," Army Research Laboratory (Apr. 2008).

(56)

References Cited

OTHER PUBLICATIONS

Written Opinion dated Sep. 22, 2014 in Int'l Application No. PCT/US2013/063161.

Wu et al., "Sol-gel preparation and characterization of $\text{Li}_{1.3}\text{Al}_0.3\text{Ti}_1.7(\text{PO}_4)_3$ sintered with flux of LiBO_2 ," *Rare Metals*, vol. 29, No. 5, p. 515 (2010).

Xiong et al., "Effects of Annealing Temperature on Structure and Opt-Electric Properties of Ion-Conducting LLTO Thin Films Prepared by RF Magnetron Sputtering," *Journal of Alloys and Compounds*, vol. 509, pp. 1910-1914 (2011).

Xu et al., "Structures of Orthoborate Anions and Physical Properties of Their Lithium Salt Nonaqueous Solutions," *Journal of The Electrochemical Society*, vol. 150, No. 1, pp. E74-E80 (2003).

Xu, "Nonaqueous Liquid Electrolytes for Lithium-Based Rechargeable Batteries," *Chemical Reviews*, vol. 104, pp. 1303-4417 (2004).

Yang et al., "Ionic to Mixed Ionic/Electronic Conduction Transition of Chemically Lithiated $\text{Li}_{0.33}\text{La}_{0.56}\text{TiO}_3$ at Room Temperature: Lithium-ion-Motion Dependent Electron Hopping," *Applied Physics Letters*, vol. 89, pp. 1-3 (2006).

Yu et al., "A Stable Thin-Film Lithium Electrolyte: Lithium Phosphorus Oxynitride," *J. Electrochem. Soc.*, vol. 144, No. 2, pp. 524-532 (1997).

Zallen, "The Physics of Amorphous Solids," Wiley-VCH, Ed. 1, pp. ix-xi (1983).

Zhang et al., "Effect of lithium borate addition on the physical and electrochemical properties of the lithium ion conductor $\text{Li}_3.4\text{Si}_0.4\text{P}_0.6\text{O}_4$," *Solid State Ionics*, vol. 231, pp. 109-115 (2013).

Int'l Preliminary Report on Patentability dated Dec. 22, 2014 in Int'l Application No. PCT/US2013/063161.

Int'l Search Report and Written Opinion dated Jan. 6, 2012 in Int'l Application No. PCT/US2011/046289.

Int'l Search Report and Written Opinion dated Mar. 25, 2014 in Int'l Application No. PCT/US2013/063160.

Int'l Search Report and Written Opinion dated Apr. 23, 2014 in Int'l Application No. PCT/US2013/063161.

Int'l Search Report and Written Opinion dated Aug. 15, 2013 in Int'l Application No. PCT/US2013/028672.

Int'l Search Report and Written Opinion dated Aug. 22, 2013 in Int'l Application No. PCT/US2013/028633.

Int'l Search Report and Written Opinion dated Aug. 25, 2020 in Int'l Application No. PCT/US2020/026334.

Int'l Search Report dated Feb. 17, 2017 in Int'l Application No. PCT/US2016/068105 (Partial).

Int'l Search Report dated Apr. 12, 2017 in Int'l Application No. PCT/US2016/068105 (Complete).

Jena et al., "Studies on the Ionic Transport and Structural Investigations of $\text{La}_{0.5}\text{Li}_{0.5}\text{TiO}_3$ Perovskite Synthesized by Wet Chemical Methods and the Effect of Ce, Zr Substitution at Ti site," *Journal of Materials Science*, vol. 40, pp. 4737-4748 (2005).

Jin et al., "Al-doped $\text{Li}_7\text{La}_3\text{Zr}_2\text{O}_{12}$ synthesized by a polymerized complex method," *Journal of Power Sources*, vol. 196, pp. 8683-8687 (2011).

Jin et al., "All-Solid-State Rechargeable Lithium Ion Battery Fabrication with Al-Doped $\text{Li}_7\text{La}_3\text{Zr}_2\text{O}_{12}$ Solid Electrolyte," Retrieved from <<http://international.dep.anl.gov/Postdocs/Symposium/Program/Presentations/32.pdf>>, Download date: Oct. 8, 2012, original posting date: unknown, 1 page.

Jin et al., "Bulk solid state rechargeable lithium ion battery fabrication with Al-doped $\text{Li}_7\text{La}_3\text{Zr}_2\text{O}_{12}$ electrolyte and $\text{Cu}_0.1\text{V}_2\text{O}_5$ cathode," *Electrochimica Acta*, vol. 89, pp. 407-412 (2013).

Jin, "Processing and characterization of secondary solid-state Li-Ion batteries," Dissertation submitted to the University of Notre Dame, 128 pages (Apr. 2013).

Jinlian et al., "Enhanced high temperature performance of LiMn_2O_4 coated with Li_3BO_3 solid electrolyte," *Bull. Mater. Sci.*, vol. 36, No. 4, pp. 687-691 (2013).

Kanamura et al., "Three Dimensionally ordered composite solid materials for all solid-state rechargeable lithium batteries" *Journal of Power Sources*, 146, pp. 86-89, 2005.

Khatun et al., Impact of Lithium Composition on Structural, Electronic and Optical Properties of Lithium Cobaltite Prepared by Solid-state Reaction *Journal of Scientific Research*, vol. 6, No. 2, pp. 217-231 (2014).

Kim et al., "Characterization of the Interface Between LiCoO_2 and $\text{Li}_7\text{La}_3\text{Zr}_2\text{O}_{12}$ in an All-Solid-State Rechargeable Lithium Battery," *Journal of Power Sources*, vol. 196, pp. 764-767 (2011).

Kishida et al., "Microstructure of the LiCoO_2 (cathode)/ $\text{La}_{2/3-x}\text{Li}_x\text{TiO}_3$ (electrolyte) Interface and its Influences on the Electrochemical Properties," *Acta Materialia*, vol. 55, No. 14, pp. 4713-4722 (2007).

Kitaoka et al., "Preparation of $\text{La}_{0.5}\text{Li}_{0.5}\text{TiO}_3$ Perovskite Thin Films by the Sol-Gel Method," *Journal of Materials Science*, vol. 32, pp. 2063-2070 (1997).

Kobayashi et al., "All-Solid-State Lithium Secondary Battery with Ceramic/Polymer Composite Electrolyte," *Solid State Ionics*, vol. 152-153, pp. 137-142 (2002).

Kokal et al., "Sol-gel Synthesis and Lithium Ion Conductivity of $\text{Li}_7\text{La}_3\text{Zr}_2\text{O}_{12}$ with a Garnet-Related Type Structure," *Solid State Ionics*, vol. 185, pp. 42-46 (2011).

Kotobuki et al., "Fabrication of All-Solid-State lithium battery using novel garnet type electrolyte," *ECS Meeting Abstracts* (2010).

Kotobuki et al., "Fabrication of Three-Dimensional Battery Using Ceramic Electrolyte with Honeycomb Structure by Sol-Gel Process," *Journal of The Electrochemical Society*, vol. 157, No. 4, pp. A493-A498 (2010).

Kreiter et al., "Sol-gel Routes for Microporous Zirconia and Titania Membranes," *J. Sol-Gel Sci. Technol.*, vol. 48, pp. 203-211 (2008).

Laughlin et al., "Using Sol-Gel Chemistry to Synthesize a Material with Properties Suited for Chemical Sensing," *Journal of Chemical Education*, vol. 77, No. 1, pp. 77-78 (2000).

Lee et al., "The Production of LiCoO_2 Cathode Thick Films for an All-Solid-State Microbattery," *Journal of Ceramic Processing Research*, vol. 8, No. 2, pp. 106-109 (2007).

Li et al., "Developments of electrolyte systems for lithium-sulfur batteries: a review," *Frontiers in Energy Research*, vol. 3, No. 5, pp. 1-12 (2015).

Li et al., "Physical and Electrochemical Characterization of Amorphous Lithium Lanthanum Titanate Solid Electrolyte Thin-Film Fabricated by e-beam Evaporation," *Thin Solid Films*, vol. 515, pp. 1886-1892 (2006).

Li et al., "Synthesis and Characterization of Li ion Conducting $\text{La}_{2/3-x}\text{Li}_x\text{TiO}_3$ by a Polymerizable Complex Method," *Ceramics International*, vol. 33, pp. 1591-1595 (2007).

Liu et al., "Enhanced high temperature performance of LiMn_2O_4 coated with Li_3BO_3 solid electrolyte," *Bull. Mater. Sci.*, vol. 36, No. 4, pp. 687-691 (2013).

Ma, Ying, "Ceria-based Nanostructured Materials for Low-Temperature Solid Oxide Fuel Cells," School of Information and Communication Technology, Functional Materials Division, Royal Institute of Technology, 52 pages (2012).

Machida et al., "All-Solid-State Lithium Battery with $\text{LiCo}_0.3\text{Ni}_0.7\text{O}_2$ Fine Powder as Cathode Materials with an Amorphous Sulfide Electrolyte," *Journal of The Electrochemical Society*, vol. 149, No. 6, pp. A688-A693 (2002).

Maqueda et al., "Structural, Microstructural and Transport Properties Study of Lanthanum Lithium Titanium Perovskite Thin Films Grown by Pulsed Laser Deposition," *Thin Solid Films*, vol. 516, pp. 1651-1655 (2008).

Masset et al., "Thermal activated (thermal) battery technology Part II Molten salt electrolytes," *Journal of Power Sources*, vol. 164, pp. 397-414 (2007).

Mateishina et al., "Solid-State Electrochemical Lithium Cells with Oxide Electrodes and Composite Solid Electrolyte," *Russian Journal of Electrochemistry*, vol. 43, No. 5, pp. 606-608 (2007).

Meda et al., "Lipon Thin Films Grown by Plasma-Enhanced Metalorganic Chemical Vapor Deposition in a $\text{N}_2\text{-H}_2\text{-Ar}$ Gas Mixture," *Thin Solid Films*, vol. 520, pp. 1799-1803 (2012).

Mei et al., "Role of amorphous boundary layer in enhancing ionic conductivity of lithium-lanthanum-titanate electrolyte," *Electrochimica Acta*, vol. 55, pp. 2958-2963 (2010).

Munshi, "Handbook of Solid State Batteries & Capacitors," World Scientific, Chapters 10-12 (1995).

(56)

References Cited

OTHER PUBLICATIONS

Murugan et al., "Fast Lithium Ion Conduction in Garnet-Type $\text{Li}_7\text{La}_3\text{Zr}_2\text{O}_{12}$," *Angewandte Chemie International Edition*, vol. 46, pp. 7778-7781 (2007).

Nagata et al., "All Solid Battery with Phosphate Compounds Made Through Sintering Process," *Journal of Power Sources*, vol. 174, pp. 832-837 (2007).

Nimisha et al., "Chemical and Microstructural Modifications in LiPON Thin Films Exposed to Atmospheric Humidity," *Solid State Ionics*, vol. 185, pp. 47-51 (2011).

Office Action and Search Report dated Jan. 20, 2021 in TW Application No. 109111527 (with Brief Summary of Relevant Portions of Office Action).

Office Action dated Jan. 2, 2015 in U.S. Appl. No. 12/198,421 by Johnson.

Office Action dated Jan. 7, 2013 in U.S. Appl. No. 12/198,421 by Johnson.

Office Action dated Jan. 12, 2022 in U.S. Appl. No. 16/592,562, by Allie.

Office Action dated Jan. 15, 2015 in U.S. Appl. No. 13/829,951 by Johnson.

Office Action dated Jan. 16, 2018 in JP Application No. 2015-535773.

Office Action dated Jan. 17, 2017 in CN Application No. 201380052635.
Office Action dated Jan. 18, 2017 in U.S. Appl. No. 13/829,525, by Johnson.

Zhang et al., "Study on Synthesis and Evolution of Sodium Potassium Niobate Ceramic Powders by an Oxalic Acid-Based Sol-Gel Method," *Journal of Sol-Gel Science and Technology*, vol. 57, pp. 31-35 (2011).

International Search Report dated May 3, 2022 in International Application No. PCT/US2022/011012.

Office Action dated May 16, 2022 in U.S. Appl. No. 16/838,706, by Johnson.

Office Action dated Jun. 20, 2022 in U.S. Appl. No. 16/918,647, by Johnson.

Obrovac et al., "Reversible Cycling of Crystalline Silicon Powder," *Journal of the Electrochemical Society*, vol. 154, No. 2, pp. A103-A108 (2007).

Limthongkul et al., "Electrochemically-Driven Solid State Amorphization in Lithium-Silicon Alloys and Implications for Lithium Storage," *Acta Materialia*, vol. 51, pp. 1103-1113 (2003).

Datta et al., "Silicon and Carbon Based Composite Anodes for Lithium Ion Batteries," *Journal of Power Sources*, vol. 158, pp. 557-563 (2006).

Read et al., "Characterization of the Lithium/Oxygen Organic Electrolyte Battery," *Journal of the Electrochemical Society*, vol. 149, No. 9, pp. A1190-A1195 (2002).

Abraham et al., "A Polymer Electrolyte-Based Rechargeable Lithium/Oxygen Battery," *Journal of the Electrochemical Society*, vol. 143, No. 1, pp. 1-5 (1996).

Miles et al., "Cation Effects on the Electrode Reduction of Molten Nitrates," *Journal of the Electrochemical Society*, vol. 127, pp. 1761-1766 (1980).

Briant et al., "Ionic Conductivity in Lithium and Lithium-Sodium Beta Alumina," *Journal of the Electrochemical Society*, vol. 128, No. 9, pp. 1830-1834 (1981).

Wang et al., "Ionic Conductivities and Structure of Lithium Phosphorus Oxynitride Glasses," *Journal of Non-Crystalline Solids*, vol. 183, pp. 297-306 (1995).

Kotobuki et al., "Fabrication of All-Solid-State Lithium Battery with Lithium Metal Anode Using Al_2O_3 -Added $\text{Li}_7\text{La}_3\text{Zr}_2\text{O}_{12}$ Solid Electrolyte," *Journal of Power Sources*, vol. 196, pp. 7750-7754 (2011).

Kotobuki et al., "Compatibility of $\text{Li}_7\text{La}_3\text{Zr}_2\text{O}_{12}$ Solid Electrolyte to All-Solid-State Battery Using Li Metal Anode," *Journal of the Electrochemical Society*, vol. 157, No. 10, pp. A1076-A1079 (2010).

Miles, Melvin H., "Lithium Batteries Using Molten Nitrate Electrolytes," *Battery Conference on Applications and Advances. The Fourteenth Annual*, pp. 39-42 (1999).

Int'l Search Report and Written Opinion dated Mar. 16, 2017 in Int'l Application No. PCT/US2017/014035.

International Preliminary Report on Patentability dated Aug. 2, 2018 in International Application No. PCT/US2017/014035.

* cited by examiner

Fig. 1

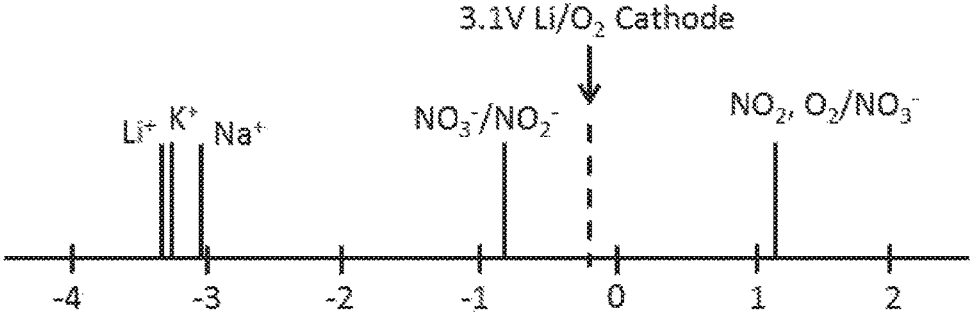

Fig. 2

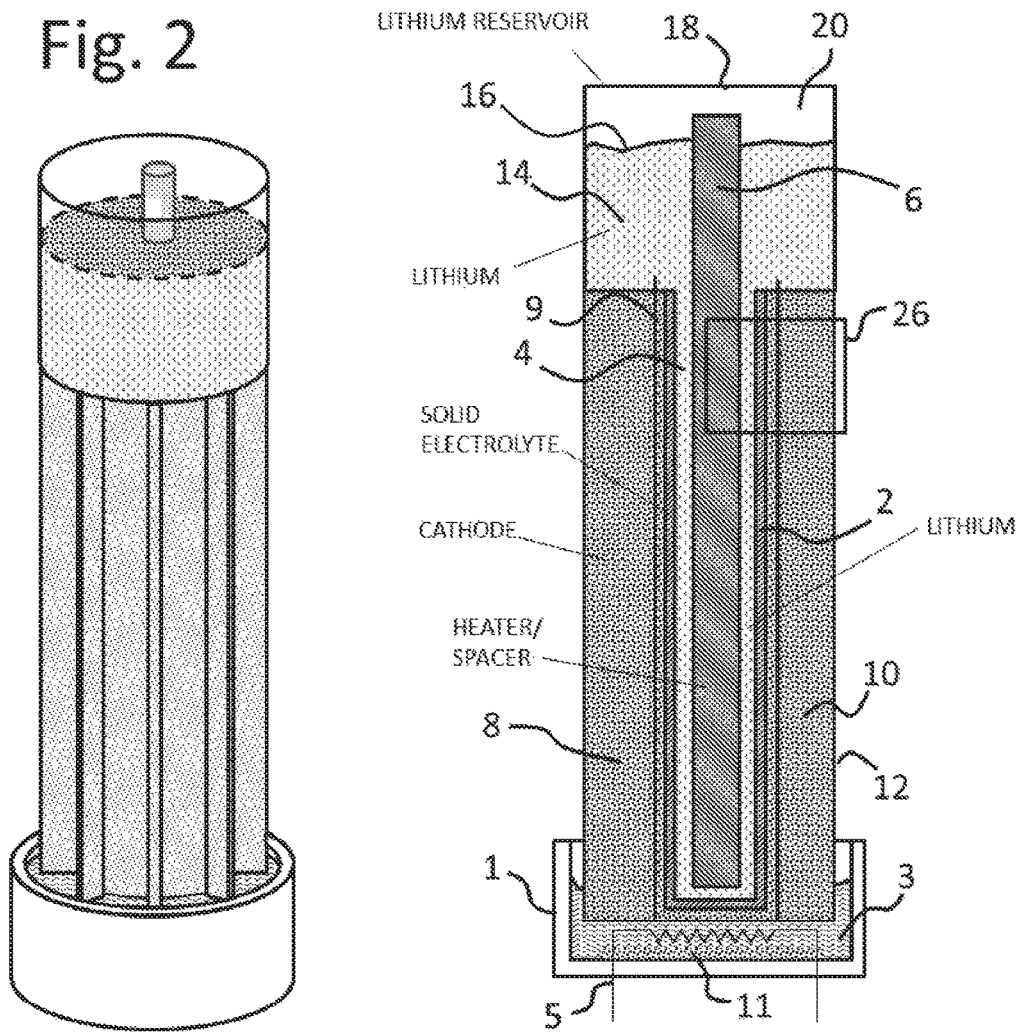
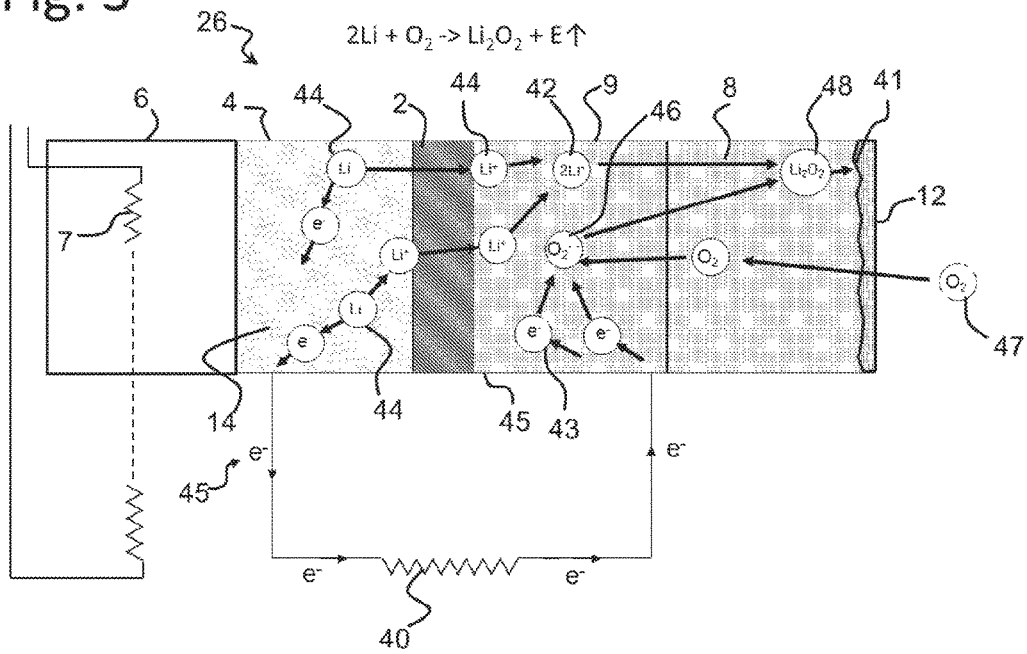

Fig. 3



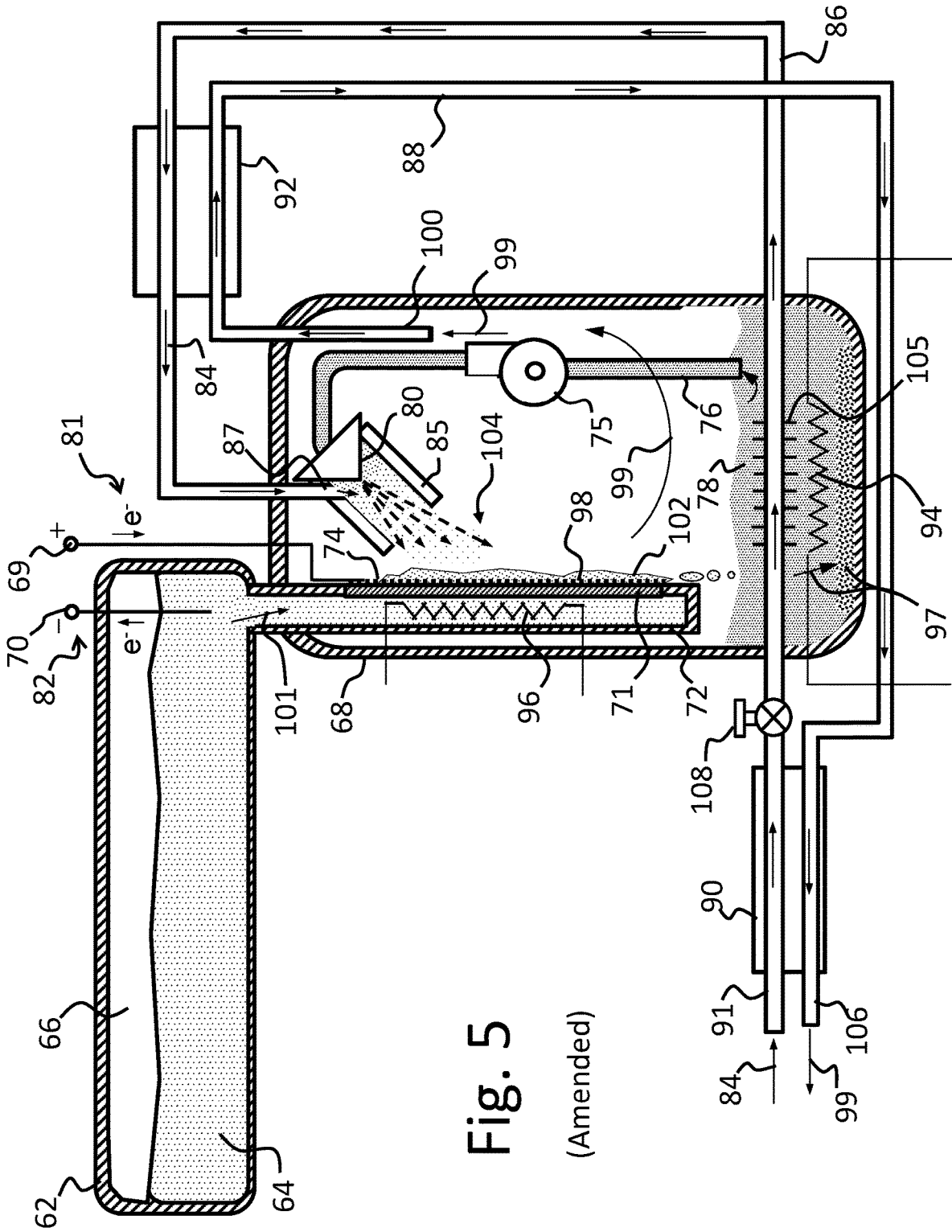

Fig. 5
(Amended)

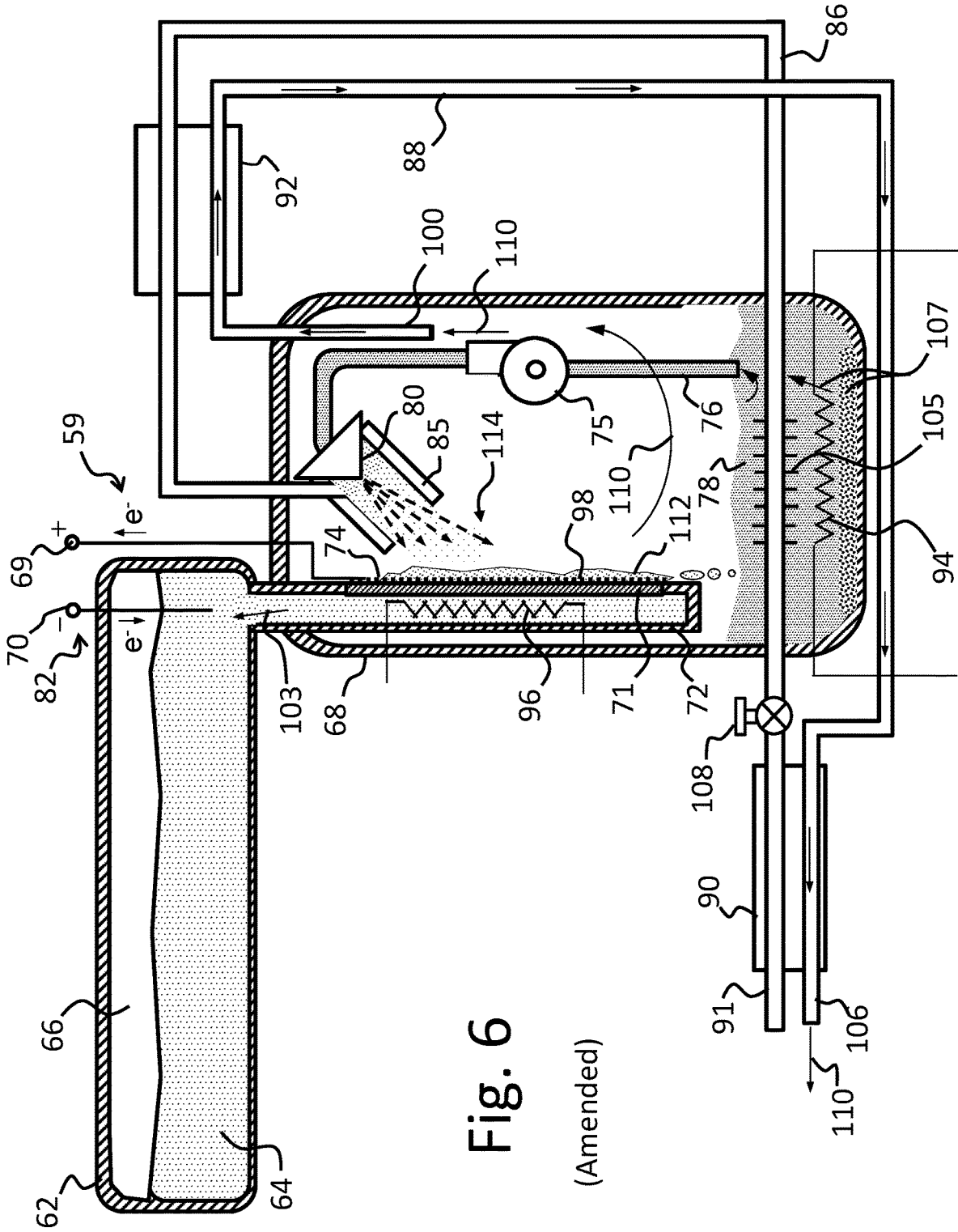

Fig. 6

(Amended)

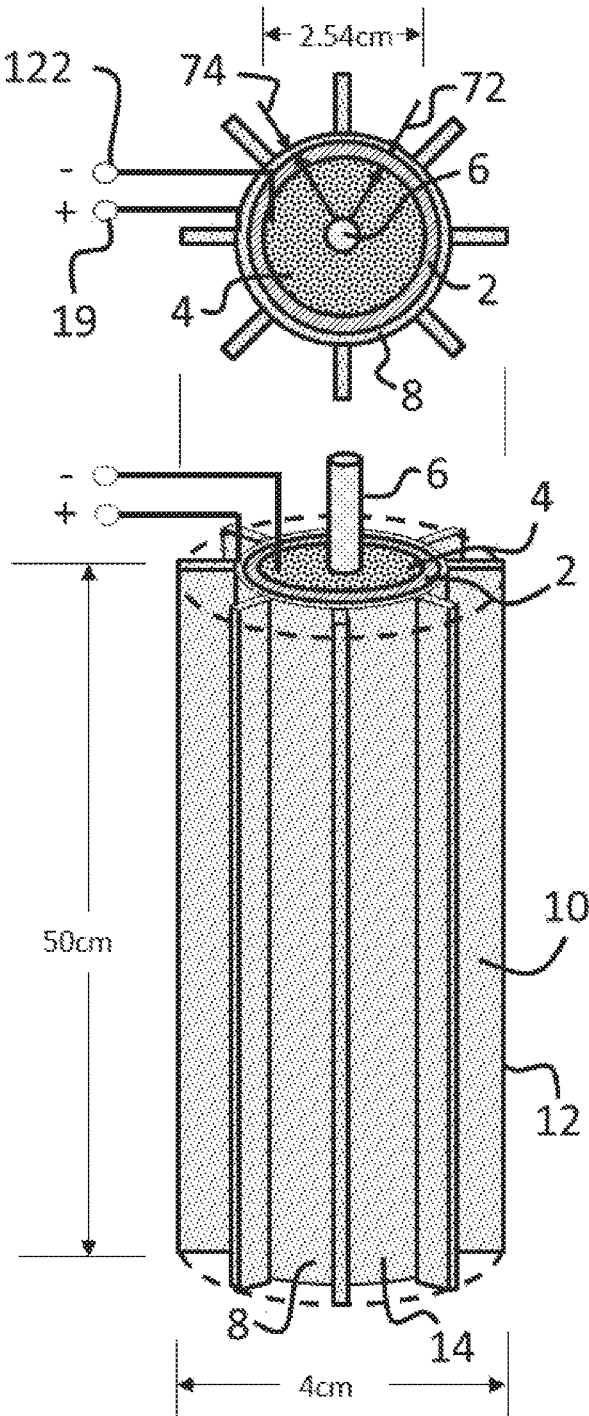

Fig. 7

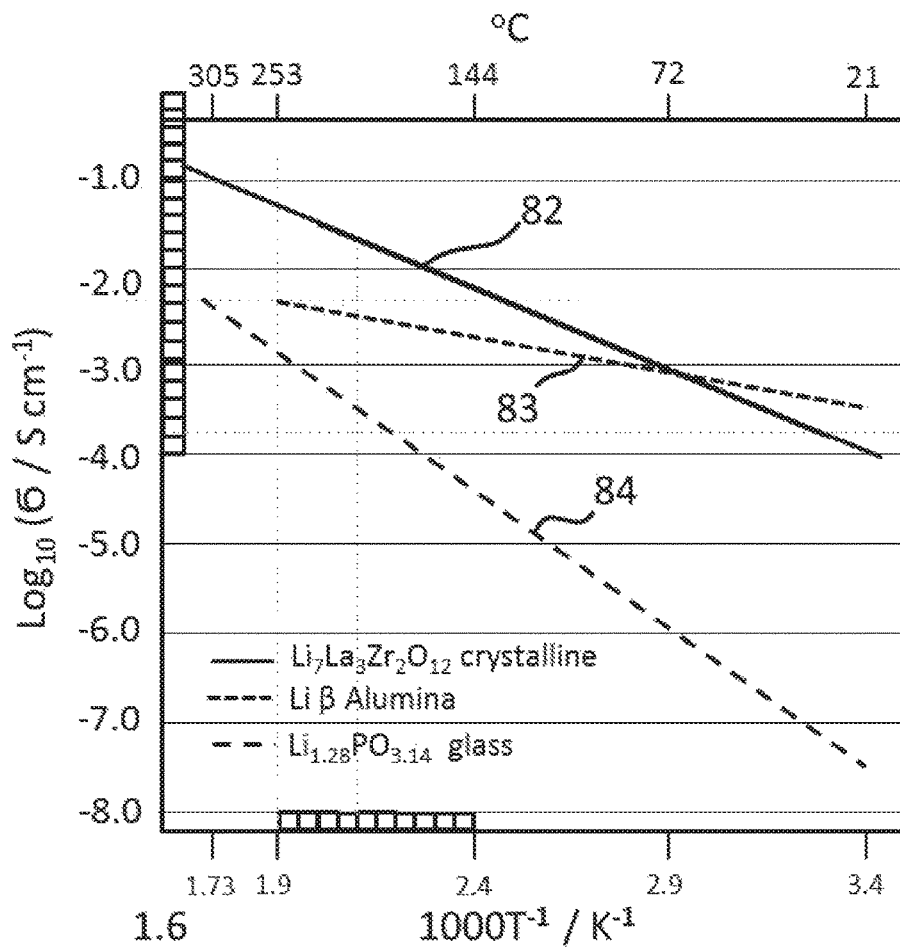

Fig. 8

**JOHNSON LITHIUM OXYGEN
ELECTROCHEMICAL ENGINE**

Matter enclosed in heavy brackets [] appears in the original patent but forms no part of this reissue specification; matter printed in italics indicates the additions made by reissue; a claim printed with strikethrough indicates that the claim was canceled, disclaimed, or held invalid by a prior post-patent action or proceeding.

CROSS-REFERENCE TO RELATED
APPLICATION

This application is a reissue of U.S. Pat. No. 10,218,044, issued on Feb. 26, 2019 from U.S. application Ser. No. 15/408,991, filed Jan. 18, 2017, which claims priority to U.S. Provisional Application No. 62/281,875, filed Jan. 22, 2016, the [disclosure] disclosures of which [is] are herein incorporated by reference in their entirety.

BACKGROUND OF THE INVENTION

The need for high performance and reliable energy storage in the modern society is well documented. Lithium batteries represent a very attractive solution to these energy needs due to their superior energy density and high performance. However, available Li-ion storage materials limit the specific energy of conventional Li-ion batteries. While lithium has one of the highest specific capacities of any anode (3861 mAh/g), typical cathode materials such as MnO₂, V₂O₅, LiCoO₂ and (CF)_n have specific capacities less than 200 mAh/g.

Recently, lithium/oxygen (Li/O₂) or lithium air batteries have been suggested as a means for avoiding the limitations of today's lithium ion cells. In these batteries, lithium metal anodes are used to maximize anode capacity and the cathode capacity of Li air batteries is maximized by not storing the cathode active material in the battery. Instead, ambient O₂ is reduced on a catalytic air electrode to form O₂²⁻, where it reacts with Li⁺ ions conducted from the anode. Aqueous lithium air batteries have been found to suffer from corrosion of the Li anode by water and suffer from less than optimum capacity because of the excess water required for effective operation.

Abraham and Jiang (J. Electrochem. Soc., 1996, 143 (1), 1-5) reported a non-aqueous Li/O₂ battery with an open circuit voltage close to 3 V, an operating voltage of 2.0 to 2.8 V, good coulomb efficiency, and some re-chargeability, but with severe capacity fade, limiting the lifetime to only a few cycles. Further, in non-aqueous cells, the electrolyte has to wet the lithium oxygen reaction product in order for it to be electrolyzed during recharge. It has been found that the limited solubility of the reaction product in available organic electrolytes necessitates the use of excess amounts of electrolyte to adequately wet the extremely high surface area nanoscale discharge deposits produced in the cathode. Thus, the required excess electrolyte significantly decreases high energy density that would otherwise be available in lithium oxygen cells.

Operation of Li/O₂ cells depends on the diffusion of oxygen into the air cathode. Oxygen absorption is a function of the electrolyte's Bunsen coefficient (α), electrolyte conductivity (σ), and viscosity (η). It is known that as the solvent's viscosity increases, there are decreases in lithium reaction capacity and Bunsen coefficients. Additionally, the electrolyte has an even more direct effect on overall cell

capacity as the ability to dissolve reaction product is crucial. This problem has persisted in one form or another in known batteries.

Indeed, high rates of capacity fade remain a problem for non-aqueous rechargeable lithium air batteries and have represented a significant barrier to their commercialization. The high fade is attributed primarily to parasitic reactions occurring between the electrolyte and the mossy lithium powder and dendrites formed at the anode-electrolyte interface during cell recharge, as well as the passivation reactions between the electrolyte and the LiO₂ radical which occurs as an intermediate step in reducing Li₂O₂ during recharge.

During recharge, lithium ions are conducted across the electrolyte separator with lithium being plated at the anode. The recharge process can be complicated by the formation of low density lithium dendrites and lithium powder as opposed to a dense lithium metal film. In addition to passivation reactions with the electrolyte, the mossy lithium formed during recharge can be oxidized in the presence of oxygen into mossy lithium oxide. A thick layer of lithium oxide and/or electrolyte passivation reaction product on the anode can increase the impedance of the cell and thereby lower performance. Formation of mossy lithium with cycling can also result in large amounts of lithium being disconnected within the cell and thereby being rendered ineffective.

Lithium dendrites can penetrate the separator, resulting in internal short circuits within the cell. Repeated cycling causes the electrolyte to break down, in addition to reducing the oxygen passivation material coated on the anode surface. This results in the formation of a layer composed of mossy lithium, lithium-oxide and lithium-electrolyte reaction products at the metal anode's surface which drives up cell impedance and consumes the electrolyte, bringing about cell dry out.

Attempts to use active (non lithium metal) anodes to eliminate dendritic lithium plating have not been successful because of the similarities in the structure of the anode and cathode. In such lithium air "ion" batteries, both the anode and cathode contain carbon or another electronic conductor as a medium for providing electronic continuity. Carbon black in the cathode provides electronic continuity and reaction sites for lithium oxide formation. To form an active anode, graphitic carbon is included in the anode for intercalation of lithium and carbon black is included for electronic continuity. Unfortunately, the use of graphite and carbon black in the anode can also provide reaction sites for lithium oxide formation. At a reaction potential of approximately 3 volts relative to the low voltage of lithium intercalation into graphite, oxygen reactions would dominate in the anode as well as in the cathode. Applying existing lithium ion battery construction techniques to lithium oxygen cells would allow oxygen to diffuse throughout all elements of the cell structure. With lithium/oxygen reactions occurring in both the anode and cathode, creation of a voltage potential differential between the two is difficult. An equal oxidation reaction potential would exist within the two electrodes, resulting in no voltage.

As a solution to the problem of dendritic lithium plating and uncontrolled oxygen diffusion, known aqueous and non-aqueous lithium air batteries have included a barrier electrolyte separator, typically a ceramic material, to protect the lithium anode and provide a hard surface onto which lithium can be plated during recharge. However, formation of a reliable, cost effective barrier has been difficult. A lithium air cell employing a protective solid state lithium ion conductive barrier as a separator to protect lithium in a

lithium air cell is described in U.S. Pat. No. 7,691,536 of Johnson. Thin film barriers have limited effectiveness in withstanding the mechanical stress associated with stripping and plating lithium at the anode or the swelling and contraction of the cathode during cycling. Moreover, thick lithium ion conductive ceramic plates, while offering excellent protective barrier properties, are extremely difficult to fabricate, add significant mass to the cell, and are rather expensive to make.

As it relates to the cathode, the dramatic decrease in cell capacity as the discharge rate is increased is attributed to the accumulation of reaction product in the cathode. At high discharge rate, oxygen entering the cathode at its surface does not have an opportunity to diffuse or otherwise transition to reaction sites deeper within the cathode. The discharge reactions occur at the cathode surface, resulting in the formation of a reaction product crust that seals the surface of the cathode and prevents additional oxygen from entering. Starved of oxygen, the discharge process cannot be sustained.

Another significant challenge with lithium air cells has been electrolyte stability within the cathode. The primary discharge product in lithium oxygen cells is Li_2O_2 . During recharge, the resulting lithium oxygen radical, LiO_2 , an intermediate product which occurs while electrolyzing Li_2O_2 , aggressively attacks and decomposes the electrolyte within the cathode, causing it to lose its effectiveness.

High temperature molten salts have been suggested as an alternative to organic electrolytes in non-aqueous lithium-air cells. U.S. Pat. No. 4,803,134 of Sammells describes a high lithium-oxygen secondary cell in which a ceramic oxygen ion conductor is employed. The cell includes a lithium-containing negative electrode in contact with a lithium ion conducting molten salt electrolyte, $\text{LiF-LiCl-Li}_2\text{O}$, separated from the positive electrode by the oxygen ion conducting solid electrolyte. The ion conductivity limitations of available solid oxide electrolytes require that such a cell be operated in the 700°C . range or higher in order to have reasonable charge/discharge cycle rates. The geometry of the cell is such that the discharge reaction product accumulates within the molten salt between the anode and the solid oxide electrolyte. The required space is an additional source of impedance within the cell.

TABLE 1

Physical properties of Molten Nitrate Electrolytes				
System	Mol %	Melt Temp ° C.	κ (S/cm) @570K	at Mol %
$\text{LiNO}_3\text{-KNO}_3$	42-58	124	0.687	50.12 mol % LiNO_3
$\text{LiNO}_3\text{-RbNO}_3$	30-70	148	0.539	50 mol % RbNO_3
$\text{NaNO}_3\text{-RbNO}_3$	44-56	178	0.519	50 mol % RbNO_3
$\text{LiNO}_3\text{-NaNO}_3$	56-44	187	0.985	49.96 mol % NaNO_3
$\text{NaNO}_3\text{-KNO}_3$	46-54	222	0.66	50.31 mol % NaNO_3
$\text{KNO}_3\text{-RbNO}_3$	30-70	290	0.394	70 mol % RbNO_3

Molten nitrates also offer a viable solution and the physical properties of molten nitrate electrolytes are summarized in Table 1 (taken from Lithium Batteries Using Molten Nitrate Electrolytes by Melvin H. Miles; Research Depart-

ment (Code 4T4220D); Naval Air Warfare Center Weapons Division; China Luke, Calif. 93555-61000).

The electrochemical oxidation of the molten LiNO_3 occurs at about 1.1 V vs. $\text{Ag+}/\text{Ag}$ or 4.5 V vs. $\text{Li+}/\text{Li}$. The electrochemical reduction of LiNO_3 occurs at about -0.9V vs. $\text{Ag+}/\text{Ag}$, and thus these two reactions define a 2.0V electrochemical stability region for molten LiNO_3 at 300°C . and are defined as follows:

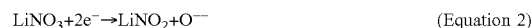

This work with molten nitrates was not performed with lithium air cells in mind; however, the effective operating voltage window for the electrolyte is suitable for such an application. As indicated by the reaction potential line in FIG. 1, applying a recharge voltage of 4.5V referenced to the lithium anode can cause lithium nitrate to decompose to lithium nitrite, releasing oxygen. On the other hand, lithium can reduce LiNO_3 to Li_2O and LiNO_2 . This reaction occurs when the LiNO_3 voltage drops below 2.5V relative to lithium. As long as there is dissolved oxygen in the electrolyte, the reaction kinetics will favor the lithium oxygen reactions over LiNO_3 reduction. Oxide ions are readily converted to peroxide (O_2^{2-}) and aggressive superoxide (O_2^-) ions in NaNO_3 and KNO_3 melts (M. H. Miles et al., J. Electrochem. Soc., 127,1761 (1980)).

A need remains for a lithium air cell which overcomes problems associated with those of the prior art.

BRIEF SUMMARY OF THE INVENTION

A rechargeable lithium air battery comprises a ceramic separator forming an anode chamber, a molten lithium anode contained in the anode chamber, an air cathode, and a non-aqueous electrolyte, wherein the cathode has a temperature gradient comprising a low temperature region and a high temperature region, and wherein the temperature gradient provides a flow system for reaction product produced by the battery.

BRIEF DESCRIPTION OF THE SEVERAL VIEWS OF THE DRAWINGS

The foregoing summary, as well as the following detailed description of the invention, will be better understood when read in conjunction with the appended drawings. For the purpose of illustrating the invention, there are shown in the drawings embodiments which are presently preferred. It should be understood, however, that the invention is not limited to the precise arrangements and instrumentalities shown.

In the drawings:

FIG. 1 is a diagram depicting electrochemical reaction potentials in molten lithium nitrate at 300°C .;

FIG. 2 is a schematic of a battery cell according to one embodiment of the present invention;

FIG. 3 is a schematic of a battery cell according to another embodiment of the present invention in discharge;

FIG. 4 is a schematic of the battery cell of FIG. 3 in recharge;

FIG. 5 is a schematic of a high performance battery cell according to a further embodiment of the invention in discharge;

FIG. 6 is a schematic of a high performance battery cell of FIG. 5 in recharge;

FIG. 7 is a schematic of a battery cell according to a further embodiment of the invention; and

FIG. 8 is an Arrhenius plot showing lithium ion conductivities of several solid ceramic electrolytes.

DETAILED DESCRIPTION OF THE INVENTION

This invention relates generally to energy storage, and more particularly to a lithium air electrochemical cell. For the purposes of this disclosure, the terms lithium air cell, lithium air electrochemical engine and lithium oxygen battery are used interchangeably.

The present invention provides a rechargeable lithium air cell having a high rate of cell charge/discharge with limited capacity fade, high energy density, high power density, and the ability to operate on oxygen from ambient air. As such, it removes significant barriers that have prevented the commercialization of lithium air cells. For example, the formation of mossy lithium powder and dendrites at the anode-electrolyte interface during cell recharge are eliminated by the use of molten lithium supplied as a flow reactant to the anode side of a stable solid state ceramic electrolyte. The battery according to the invention also includes a flow system for removing reaction product from the cathode.

The reactions of lithium with oxygen are as follows:

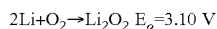

To avoid problems associated with past approaches to lithium air cells, a lithium air cell according to the invention may be operated at a wide range of temperatures in the range of 20° C. to 700° C., which include elevated temperatures, such as the preferred temperatures of about 200° C. to 450° C., more preferably about 200° to about 250° C. The solvent in the electrolyte may be selected based on the preferred operating temperature of the specific battery. Operation at elevated temperature enables faster kinetics for higher power density, thus eliminating a major issue associated with lithium air technology. Further, operation at elevated temperature also allows for the use of high temperature organic electrolytes and inorganic, molten salt electrolyte solutions that have high electrochemical stability, thus avoiding another of the major problems that has plagued conventional approaches to lithium air cells. Selected inorganic molten salts have good solubility of lithium/oxygen reaction products, thus allowing better control of cell kinetics.

The rechargeable air battery according to the invention contains a ceramic separator which forms an anode chamber, a molten lithium anode contained in the anode chamber, an air cathode, and a non-aqueous electrolyte. Each of these components will be described in more detail below.

The cell further comprises a flow system which is provided by a temperature gradient across the cathode. More specifically, the cathode has two temperature regions: a high temperature region (preferably located near the anode, where the reaction takes place) and a low temperature region which is located further away from the anode. As the electrolyte circulates through the cell during discharge, the reaction product produced by the battery migrates from the high temperature region to the low temperature region.

The anode chamber is preferably formed by a sealed ceramic enclosure that is lithium ion conductive and which functions as the separator for the battery. Preferably, the ceramic material is stable in contact with lithium metal and protects the anode from ambient oxygen and moisture. Preferred materials include lithium ion conducting glasses

such as lithium beta alumina, lithium phosphate glass, lithium lanthanum zirconium oxide (LLZO), Al_2O_3 :
 $\text{Li}_7\text{La}_3\text{Zr}_2\text{O}_{12}$, lithium aluminum germanium phosphate (LAGP), and lithium aluminum titanium phosphate (LATP).

In a preferred embodiment, the anode chamber is maintained at about 20° C. to about 200° C., more preferably at about 175° C. to about 200° C., most preferably about 175° C. to about 195° C.

The anode comprises metallic lithium in a molten state; lithium has a melting point of about 180° C. The benefit of the molten lithium anode is that it limits undesirable dendrite growth in the cell.

The non-aqueous electrolyte is chosen for stability in contact with lithium. Thus, a breach in the ceramic enclosure will not result in rapid reactions, particularly because air ingress into the cell will be controlled. Preferred electrolytes include molten inorganic salts, for example, alkali nitrates such as lithium and sodium nitrate, alkali chlorides and bromides such as lithium, potassium and sodium chlorides and bromides, alkali carbonates such as sodium and lithium carbonates, as well as sodium nitrate-potassium nitrate (NaNO_3 — KNO_3) eutectic mixtures and silane and siloxane-based compounds including, for example, hexamethylcyclotrisiloxane, octamethylcyclotetrasiloxane, dodecamethylpentasiloxane, and dodecamethylhexatetrasiloxane with or without polyethylene oxide groups.

The inorganic salt, silane, or siloxane in the electrolyte is present in a solvent. The solvent is not limited, and may be selected based on the preferred operating temperature of the battery. A preferred solvent is LiCl—KCl eutectic, which works at a temperature of 350° C. to 450° C. The temperature of the electrolyte may be controlled with a heater and is preferably about 200° C. to 450° C.

The air cathode or positive electrode is porous so that oxygen can penetrate through the pores and form lithium peroxide as the reaction product; electrolyte also flows through the porous cathode. The cathode is preferably formed from a porous ceramic material which is lithium conductive and which is infiltrated or impregnated with a metal nitrate such as silver nitrate or a carbon material such as carbon fibers, carbon black, or carbon foam. Preferred porous ceramic materials include LLZO, LAGP, LATP, and lithium oxyanions such as lithium carbonate; most preferred is LLZO. In another preferred embodiment, the cathode contains a carbon material, a heat resistance polymer binder such as polyimide, and a metal oxide catalyst. An exemplary cathode material of this type contains about 60% by weight vapor grown carbon fibers, about 30% polyimide binder, and about 10% manganese dioxide. The cathode may also be constructed of electrically conductive sintered metal oxide powder, sintered metal nitride, carbon, or sintered silicon carbide.

As a preferred example, porous lithium lanthanum zirconium oxide (LLZO) ceramic substrates are prepared by pressing 10-15 grams of LLZO powder into a disc at 1000 psi. The disc is densified by placing in a furnace at 1000° C. for a period of 1 hour. The disc is then impregnated with a metal nitrate such as silver nitrate to form the cathode.

A thermodynamic process is employed to remove and supply electrolyte to cathode reaction sites. In its basic configuration, a temperature gradient is maintained across the structure of the cathode wetted by the electrolyte. The active charge/discharge reaction region of the cell forms the higher temperature region of the gradient. As a result of the temperature gradient, during discharge, reaction product accumulated within the electrolyte at the higher temperature region migrates to the lower temperature region where it

precipitates/solidifies. The configuration of the cell is such that reaction product can accumulate within the lower temperature region physically away from the higher temperature reaction region of the cell. Accumulation of reaction product in the lower temperature region prevents it from significantly affecting the charge/discharge cell kinetics occurring in the higher temperature cathode reaction region. Ultimately, the cooled and settled reaction product will become re-dissolved in the electrolyte. This flow system is a key attribute of the inventive batteries.

In an alternative embodiment, the cell contains a pump to circulate the electrolyte across the temperature gradient. Such a cell contains a molten or another appropriate electrolyte reservoir and a temperature control system for controlling the relative temperatures of the cathode and the reservoir. Further, a heating element is employed for electrolyte temperature control. The pump system cycles electrolyte between the cathode and the electrolyte reservoir, which are adjacent to and in fluid communication with each other. Operation is such that during discharge, the cathode is maintained at a temperature that is elevated above that of the electrolyte reservoir. Reaction product dissolved in the electrolyte at high temperature in the cathode is carried to the electrolyte reservoir where it precipitates due to the lower temperature therein. In contrast, during charge, heat is supplied to the reservoir to maintain solubility of reaction product into the electrolyte. During charge, the electrolyte carries dissolved reaction product from the reservoir to the cathode, where it is electrolyzed. Oxygen is released and lithium ions are conducted through the ceramic separator such that lithium metal is plated at the anode. Electrolyte depleted of reaction product circulates back to the reservoir where it dissolves and carries more reaction product to the cathode as the charge process continues. The configuration is such that the reaction product is temporarily stored as a solid in the electrolyte reservoir as opposed to the cathode. Operation in this manner enables the cathode to be maintained in an optimum configuration for maximum charge and discharge performance.

FIG. 2 is a schematic drawing of a molten lithium electrochemical cell according to an embodiment of the invention. The cell is cylindrical in shape with fins running lengthwise along the cylinder and radiating outward away from the core of the cell. The basic structure is supported by hollow solid electrolyte cylinder (anode chamber) 2 which extends the length of the cell and functions as the cell separator. Molten lithium metal 14 is contained within reservoir 18 at the top of the cell and inside annular cavity 4 such that molten lithium is free to flow down from reservoir 18 into annular cavity 4. The top level of the molten anode 16 is not expected to totally fill the headspace 20 of the cell. Electrical heater element 6 runs the length of the cell and is positioned to maintain the lithium in a molten state. Heater 6 is part of the core structure that forms annular cavity 4 between the heater and the inner wall of the solid electrolyte 2 where molten lithium 14 is contained. Lithium 14 serves as the anode of the cell. Finned cathode cylinder 8 is positioned over the outer surface of electrolyte cylinder 2. The core of the fin is shown by 9. Cathode 8 is a porous structure containing liquid electrolyte which, due to its finned structure, is configured to have a wicking effect to maintain distribution of electrolyte therein. The reaction in the cell occurs at the interface where the cathode touches the separator, which is the hotter (high temperature) region of the cathode. The reaction product will not settle in this hot portion of the cathode, but rather on the colder side of the cathode (low temperature region). This allows for deeper

cathode access. The cell preferably operates at 250° C. to 700° C. such that the eutectic salt mixture or other electrolyte is maintained in a molten state. Fins 10 extend into the surrounding air to facilitate heat transfer to the air such that heat supplied to the core induces a temperature gradient radially outward that is maintained between tips 12 of the fins 10 and the molten lithium at the core of the cell.

Dissolved reaction product 11 generated during discharge will preferentially precipitate in the lower temperature regions of the fins as opposed to the warmer core region. Molten electrolyte reservoir 1 contains excess electrolyte 3 and electrolyte that has been displaced by reaction product as it is produced and deposited within fins 10. Reservoir 1 may be maintained at a temperature that is lower than the core of the cell such that the reaction product preferentially precipitates therein as well. The temperature of the reservoir is controlled by heater element 5. During recharge, reaction product re-dissolves into the molten salt electrolyte to maintain concentration equilibrium as product is electrolyzed and lithium is re-plated at the anode. Heater 5 is used during recharge to heat the electrolyte to redissolve reaction product. The heat source for core 6 of the cell is not shown but would maintain temperature for operation during both charge and discharge.

Reservoir 18 supplies lithium 14 to annular cavity 4 so that the cavity does not become depleted as the lithium is consumed during discharge. Similarly, as lithium is reduced into the annular section during recharge, lithium is resupplied and accumulated in the reservoir.

FIGS. 3 and 4 show expanded views of radial plane cross section 26 of the cell in FIG. 2 and illustrate the operation of the cell. These Figs. show heater/spacer 6 including heater element 7, finned cathode 8, annular lithium cavity 4, solid electrolyte cylinder 2 and molten lithium anode 14. Referring to FIG. 3, oxygen 47 dissolves into the molten salt electrolyte from the cell's environment. During discharge, lithium 44 is oxidized and conducted through electrolyte separator 2 into the molten salt contained within cathode 8, giving rise to electric current flow 45 through load 40 to cathode 8. The electrons 43 oxidize molecular oxygen that is dissolved in the molten salt electrolyte, producing oxygen ions 46 to complete the reaction, with the resulting reaction product being either lithium peroxide (Li_2O_2 as 2Li^+ and O_2^{2-}) and/or lithium oxide (Li_2O as 2Li^+ and O^{2-}) ions suspended in the molten salt electrolyte solution. The two lithium ions 42 are anticipated to be individually dispersed within the electrolyte. The illustration is not intended to convey a diatomic pair bonded to each other. When the molten salt becomes saturated with reaction product, lithium peroxide 48 and/or lithium oxide begins to precipitate out of solution.

Heater element 7 located in the center region of the cell maintains the lithium anode and the electrolyte salt contained in the cathode in a molten state. Because of its location and because of the loss of heat from the cathode fins to the air surrounding the cell, a decreasing temperature exists between the core of the cell 6 and fin tips 12. The molar equilibrium of dissolved lithium/oxygen reaction product in the molten salt will be lower at the lower temperature fin tips 12 than at the high temperature cathode material 45 that is closest to the core of the cell. As such, reaction product 48 will tend to precipitate out of solution in the region of fin tips 12, resulting in a buildup of reaction product 41 in that location. Although reaction kinetics will favor the high temperature region, creation of reaction product in high temperature region 14 will cause over saturation and precipitation of reaction product in lower

temperature fin tip region 12. Migration to fin tips 12 will occur because the molar concentration of reaction product in the salt is continuous between the two regions. The salt level will naturally be uniformly distributed, limited only by mass transport rate across the concentration gradients of the dissolved product within the molten salt. Further production of reaction products in the solution in the higher temperature regions will cause precipitation of reaction product in the lower temperature region since the increase would cause over saturation in the low temperature region.

Having the reaction product accumulate in the fin tip regions of the cell is important because precipitation in this region has only very limited adverse impacts on operation of the cell. The invention thus avoids over accumulation of reaction product in the active region of the cell which could cause a reduction of ionic conductivity and could block access and diffusion of oxygen to reaction sites.

FIG. 4 depicts recharge operation of the cell. For recharge, power source 50 is connected in the circuit in place of the load. Dissolved lithium/oxygen reaction product 52, 54, 56 is electrolyzed as electrons 53 are stripped by the power source and coupled to the anode side of the cell. During the process, molecular oxygen 57 is released to the environment and lithium ions 54 are conducted through the solid state separator 2 to the anode side of the cell where electrons 53 reduce it to lithium metal.

As reaction product 58 is consumed from the molten salt electrolyte solution, its molar concentration level in the electrolyte eutectic tends lower, thus allowing additional reaction product precipitant 41 to dissolve into the electrolyte. The re-dissolved reaction product naturally migrates toward the core region of the cell due to the concentration gradient created as reaction product in the core region is removed by the recharge process. Continuous dissolving of reaction product 41 maintains a molar equilibrium concentration level of the reaction product in the electrolyte in fin tip region 12 until all of discharge reaction product 41 is re-dissolved and electrolyzed, whereby the cell will be fully charged.

FIG. 5 is a schematic diagram of a high performance lithium oxygen or lithium air cell according to a further embodiment of the invention. Lithium reservoir 62 contains molten lithium 64 at a preferred temperature of 350° C. A portion 72 of lithium reservoir 62 extends into [reactor] reaction chamber and molten salt electrolyte reservoir 68 where separator 71 interfaces with the contents of reaction chamber and molten salt electrolyte reservoir 68. Reservoir 62 optionally includes ullage pressurized gas 66 to ensure flow of molten lithium into contact with solid state electrolyte separator 71. Reservoir 62 maintains the supply 101 of lithium to separator 71 as the cell is discharged. Separator 71 is a solid lithium ion conductive material and may be lithium beta alumina or lithium lanthanum zirconium oxide (LLZO). It is preferably a solid ceramic and/or a glass electrolyte. Cathode 98 and embedded current collector 74 are coupled to the surface of separator 71 on the external side of reservoir 62. Cathode 98 includes lithium/oxygen reaction sites for charge and discharge of the cell. Current collector 74 is connected to positive terminal 69 which allows electrons 81 to travel. Power is applied to terminals 82. [Reactor] Reaction chamber and molten salt electrolyte reservoir 68 contains molten salt electrolyte 78. Pump 75 supplies molten salt electrolyte [solution] 78 through supply tube 76 to nozzle 80. Nozzle 80, tube 85 and port 87 comprise a jet pump whereby fluid supplied by pump 75 creates a low pressure region that draws air 84 into port 87 such that it flows through conduit 86 to port 87. The fluid injection

process creates a turbulent mixture region of air and molten electrolyte. It produces a washing effect as the resulting spray 104 exits the jet pump and impinges on cathode 98. This process creates an electrochemical potential between the lithium inside reservoir 62 on one side of electrolyte 71 (electrode terminal 70) and the oxygen dissolved and dispersed within electrolyte/air mixture washing through cathode 98 on the other side.

Operation of the cell is such that molten salt electrolyte 102 washing through cathode 98 dissolves lithium-air reaction products produced therein as the cell is discharged. Oxygen depleted air 99 exits the reactor chamber through port 100. Air 84 enters the cell at port 91 and passes through heat exchanger 90, heat exchanger 105 and heat exchanger 92 prior to entering reaction chamber and molten salt electrolyte reservoir 68. The flow rate can be controlled by valve 108. The heat exchangers preheat air 84 to a level such that it enters nozzle 87 near the temperature of molten salt electrolyte 78 exiting nozzle 80. Air entering the reaction chamber and molten salt electrolyte reservoir 68 is heated within heat exchangers 90 and 92 by oxygen depleted air 99 exiting the reaction chamber through conduit 88. Air passing through heat exchanger 105 inside [reactor] reaction chamber and molten salt electrolyte reservoir 68 is heated by molten electrolyte salt 78. Extraction of heat from electrolyte 78 in the electrolyte reservoir maintains its temperature below the temperature of the electrolyte 102 that is washing through cathode 98. Electric heater 96 is thermally coupled to separator 71 and supplies energy as needed to maintain the temperature of cathode 98 above the temperature the reservoir electrolyte 78 that is thermally coupled to heat exchanger 105. The effect of the thus maintained temperature difference is that electrolyte 102 washing through cathode 98 is raised to a higher temperature than electrolyte 78 that is in the reservoir. Continuous flow of electrolyte continuously dissolves and washes away reaction product being produced in cathode 98. On the other hand, when the electrolyte leaves cathode 98 and is cooled by heat exchanger 105 in the reservoir, its saturation limit for dissolved reaction product decreases, which causes a portion of the reaction product to precipitate, 97. The electric heater 94 is used to control the temperature of the electrolyte. The discharge process continues as pump 75 resupplies electrolyte 78, now depleted of reaction product, to nozzle 80 where it entrains more air and carries it to cathode 98, is reheated, and dissolves more reaction product as it occurs from lithium air reactions ongoing therein.

FIG. 6 illustrates operation of the cell under recharge conditions. Power is supplied to heater 94 to increase the solubility level of reaction product 107 in electrolyte 78. The dissolving of reaction product 107 in electrolyte 78 increases with temperature. Pump 75 pumps electrolyte 78 containing dissolved reaction product to nozzle 80 whereby it is sprayed 114 onto cathode 98. Power is applied to terminals 82 to electrolyze lithium/air reaction product in cathode 98. With the extraction of electrons 59 by a positive voltage applied to terminal 69 relative to terminal 70, reaction product is electrolyzed with oxygen 110 being released to escape [reactor] reaction chamber and molten salt electrolyte reservoir 68 via port 100. It exits the cell through port [78] 106 after passing through heat exchanger 92 and 90 to preheat incoming air. During the recharge process, lithium ions are conducted through solid electrolyte separator 71 into reservoir 62 where it is reduced to lithium by electron flow via terminal 70. The recharge process continuously electrolyzes dissolved reaction product from molten salt in cathode 98 as reaction product depleted electrolyte 112

returns to *reaction chamber and molten salt electrolyte reservoir* [78] 68, dissolves more reaction product, 107, and is pumped back to cathode 98. Molten lithium is re-supplied to reservoir 62 as indicated by arrow 103. Under recharge condition, valve 108 may optionally be closed since air intake into the reaction chamber is not needed.

In an exemplary cell shown in FIG. 7, solid electrolyte cylinder 2 with terminals 122 and 19 has an inner diameter of 2.54 cm and length of 50 cm. The volume of lithium would be $0.253 \text{ L } (\pi(2.54(\text{D})/2)^2 * 50 \text{ cm}(\text{L}) = 253.35 \text{ cm}^3)$. The electrochemical potential for the lithium/oxygen reaction is 3.14V. Assuming an under load operating output voltage of 2.5V to allow for internal impedances, the energy capacity can be determined considering the Amp-Hour capacity of lithium being 3,860 Ah/kg (2,084 Ah/ltr). At an output voltage of 2.5V, the energy available from the cell would be 9650 Wh/kg (5210 Wh/ltr). Given the 0.253 L lithium volume in the example, the cell could supply 1.3 kWh of energy.

In a cell operating at 300° C. with NaNO₃—KNO₃ molten salt eutectic electrolyte, the conductivity of the electrolyte is 0.66 S/cm. Similarly, the conductivity of the solid electrolyte containment cylinder 2 at 300° C. is 0.1 S/cm as shown in FIG. 7. Assuming that the thickness 74 in FIG. 7 of the porous cathode 8 on the surface of the solid electrolyte 2 is 0.2 cm and that the thickness 72 of the solid electrolyte is 0.1 mm, the area specific resistance of the solid electrolyte plus the liquid can be calculated as $0.403 \text{ Ohm-cm}^2 (1/(0.66 \text{ S/cm}) * 0.2 \text{ cm} + 1/(0.1 \text{ S/cm}) * 0.01 \text{ cm})$. Given the 0.7 Volt allowance for internal IR loss, the net output current under load would be 1.73 A assuming other polarization losses are negligible. In such a case, the area specific power of the cell would be 4.34 Watts. This example cell has a surface area of $399 \text{ cm}^2 (\pi * 2.54 * 50)$, therefore its power output capability would be 1.73 kW.

FIG. 8 is an Arrhenius plot showing the conductivity of several solid state ionic conductive materials that would be suitable for use as the electrolyte cylinder 2. Impedance line 83 is for lithium beta alumina (data from J. L. Briant, J. Electrochem. Soc.: Electrochemical Science And Technology; 1834 (1981)) and line 84 is for lithium phosphate glass (data from B. Wang, Journal of Non-Crystalline Solids, Volume 183, Issue 3, 2; 297-306 (1995). Conductivity values 82 for aluminum oxide doped lithium lanthanum zirconium oxide (Al₂O₃:Li₇La₃Zr₂O₁₂) are from M Koto-buki, et. al.; Journal of Power Sources 196 7750-7754 (2011)).

Sintered LLZO electrolyte had been demonstrated to be stable with lithium in all solid state batteries. (See T. Yoshida, et. al.; Journal of The Electrochemical Society, 157-10, A1076-A1079 (2010)). The cyclic voltammogram of the Li/LLZO/Li cell showed that the dissolution and deposition reactions of lithium occurred reversibly without any reaction with LLZO. This indicates that a Li metal anode can be employed in contact with LLZO electrolyte.

In an exemplary embodiment, a 1 kWh battery is designed to operate at a discharge rate of 1 C, i.e. battery totally discharged in 1 hour. Lithium has a specific energy of 11,580 Wh/kg. If the mass of the oxygen is included, the net energy density is 5,200 Wh/kg. For a 1 kWh battery, 86 g of lithium would be needed. Lithium has a discharge current capacity of 3.86 Ah/g. At a discharge rate of 1 C, the required discharge current would be 332 A (86 g * 3.86 Ah/g/1 hr). In this example, the area of the separator may be defined as 100 cm² and the solid separator as LLZO or other suitable substitute thereof. In this example the use of a 100 cm² separator results in a net current density of 3.32 A/cm². As

indicated in FIG. 8, the lithium ion conductivity, σ , of LLZO is approximately 0.1 S/cm. A separator made of this material and at a thickness, t , of 100 μm would have an impedance of $0.1 \text{ Ohm-cm}^2, (1/\sigma * t)$. The output current supplied at 1 C would have a maximum drop in voltage of 0.4V relative to the cell's open circuit voltage. The primary reaction product of the cell is Li₂O₂. The amount of air flow required to sustain a 1 C discharge rate can be determined from the required oxygen flow.

The atomic mass of lithium is 6.9 g/mole. The primary discharge reaction for the cell is $2\text{Li} + \text{O}_2 \rightarrow \text{Li}_2\text{O}_2$, 1 mole of oxygen is required for per mole of lithium. The number of moles of lithium in the reaction is 12.46, (86 g/6.9 g/mole). Therefore, 6.23 moles or 199.4 grams (6.23 moles * 32 grams/mole) of oxygen are required to balance the reaction. Air is 23% oxygen by mass so that the total amount of air needed for the reaction is 866 g, (199.4 g O₂/(0.23 g O₂/g Air). For the 1 C discharge, the air mass flow rate is 866 g/hr or 0.24 g/sec. The density of air is 0.00123 g/cm³. This gives a volumetric flow rate of 195 cm³/sec.

It will be appreciated by those skilled in the art that changes could be made to the embodiments described above without departing from the broad inventive concept thereof. It is understood, therefore, that this invention is not limited to the particular embodiments disclosed, but it is intended to cover modifications within the spirit and scope of the present invention as defined by the appended claims.

We claim:

1. A rechargeable lithium air battery comprising a ceramic separator forming an anode chamber, a molten lithium anode contained in the anode chamber, an air cathode, a non-aqueous electrolyte, and an electrolyte reservoir adjacent to the cathode, wherein the cathode has a temperature gradient comprising a low temperature region and a high temperature region, and wherein the temperature gradient provides a flow system for reaction product produced by the battery.

2. The battery according to claim 1, further comprising a pump and a temperature control system.

3. The battery according to claim 2, wherein the pump controls movement of the electrolyte between the cathode and the electrolyte reservoir.

4. The battery according to claim 2, wherein the temperature control system controls temperatures of the cathode and the electrolyte reservoir.

5. The battery according to claim 1, wherein during discharge the reaction product moves from the high temperature region of the cathode to the low temperature region of the cathode.

6. The battery according to claim 1, wherein the electrolyte comprises a molten inorganic salt.

7. The battery according to claim 1, wherein the electrolyte comprises a silane or siloxane compound.

8. The battery according to claim 1, wherein the cathode comprises a porous ceramic material.

9. The battery according to claim 8, wherein the cathode is impregnated with a metal nitride or a carbon material.

10. The battery according to claim 1, wherein the cathode comprises an electrically conductive sintered metal oxide, metal nitride, carbon, or silicon carbide.

11. The battery according to claim 1, wherein the cathode comprises carbon, a polymer binder, and a metal oxide.

12. The battery according to claim 8, wherein the porous ceramic material comprises lithium lanthanum zirconium oxide.

13. The battery according to claim 1, where the anode chamber is maintained at about 20° C. to 200° C.

13

14. The battery according to claim 1, wherein the ceramic separator comprises a lithium ion conducting glass.

15. The battery according to claim 14, wherein the lithium ion conducting glass is selected from lithium beta alumina, lithium phosphate glass, lithium lanthanum zirconium oxide, $\text{Al}_2\text{O}_3\cdot\text{Li}_7\text{La}_3\text{Zr}_2\text{O}_{12}$, lithium aluminum germanium phosphate, and lithium aluminum titanium phosphate.

16. The battery according to claim 1, wherein the battery has an operating temperature of about 200° C. to about 450° C.

17. A rechargeable lithium air battery comprising a ceramic separator forming an anode chamber, a molten lithium anode and a heater contained in the anode chamber, an air cathode, and a non-aqueous electrolyte, wherein the cathode has a temperature gradient comprising a low temperature region and a high temperature region, and wherein the temperature gradient provides a flow system for reaction product produced by the battery.

18. A rechargeable lithium air battery comprising a ceramic separator forming an anode chamber, a molten lithium anode contained in the anode chamber, an air cathode, and a non-aqueous electrolyte, wherein the cathode has a temperature gradient comprising a low temperature region and a high temperature region, the temperature gradient provides a flow system for reaction product produced by the battery, wherein the cathode comprises a core adjacent to the ceramic separator and at least one fin extending radially outward from the core, and wherein the core is the high temperature region of the cathode and the at least one fin is the low temperature region of the cathode.

19. A rechargeable lithium air battery comprising a ceramic separator forming an anode chamber, a molten lithium anode contained in the anode chamber, an air cathode, a non-aqueous electrolyte, an electrolyte reservoir adjacent to the cathode, a pump and a temperature control system, wherein the temperature control system controls temperatures of the cathode and the electrolyte reservoir, the temperature of the electrolyte reservoir is about 200° C. to about 450° C., the cathode has a temperature gradient comprising a low temperature region and a high temperature region, and wherein the temperature gradient provides a flow system for reaction product produced by the battery.

20. A rechargeable lithium air battery comprising a lithium reservoir, a reaction chamber, an air cathode, a temperature control system, and an electrolyte reservoir adjacent to the air cathode, wherein the lithium reservoir includes a ceramic separator and the electrolyte reservoir contains an inorganic non-aqueous electrolyte, the ceramic separator extends into the reaction chamber whereby lithium flows into the reaction chamber from the lithium reservoir and contacts the ceramic separator in the reaction chamber, the ceramic separator couples lithium to the inorganic non-aqueous electrolyte supplied from the electrolyte reservoir, and the inorganic non-aqueous electrolyte couples the reaction chamber to the electrolyte reservoir and carries reaction product therebetween whereby reaction product within the reaction chamber is removed.

21. The battery according to claim 20, wherein the temperature control system controls temperatures of the cathode and the electrolyte reservoir.

22. The battery according to claim 20, wherein the cathode comprises a core adjacent to the ceramic separator and at least one fin extending radially outward from the core.

23. The battery according to claim 22, and wherein the core is a high temperature region of the cathode and the at least one fin is a low temperature region of the cathode.

14

24. The battery according to claim 20, wherein the electrolyte comprises a molten inorganic salt.

25. The battery according to claim 20, wherein the electrolyte comprises a silane or siloxane compound.

26. The battery according to claim 20, wherein the cathode comprises a ceramic material.

27. The battery according to claim 20, wherein the cathode is impregnated with a metal nitride or a carbon material.

28. The battery according to claim 20, wherein the cathode comprises an electrically conductive sintered metal oxide, metal nitride, carbon, or silicon carbide.

29. The battery according to claim 20, wherein the cathode comprises carbon, a polymer binder, and a metal oxide.

30. The battery according to claim 26, wherein the ceramic material comprises lithium lanthanum zirconium oxide.

31. The battery according to claim 20, where the anode chamber is maintained at about 20° C. to 200° C.

32. The battery according to claim 20, wherein the ceramic separator comprises a lithium ion conducting glass.

33. The battery according to claim 32, wherein the lithium ion conducting glass is selected from lithium beta alumina, lithium phosphate glass, lithium lanthanum zirconium oxide, $\text{Al}_2\text{O}_3\cdot\text{Li}_7\text{La}_3\text{Zr}_2\text{O}_{12}$, lithium aluminum germanium phosphate, and lithium aluminum titanium phosphate.

34. The battery according to claim 20, wherein the battery has an operating temperature of about 200° C. to about 450° C.

35. A rechargeable lithium air battery comprising:
 a supply of air flow,
 an air cathode,
 a heat exchanger for transferring heat to air flowing to the air cathode from air leaving the air cathode,
 a pump for supplying air to the air cathode,
 a temperature control system,
 a lithium ion conductive solid ceramic electrolyte
 a lithium reservoir,
 an inorganic electrolyte reservoir,
 a molten lithium anode contained in the lithium reservoir,
 and
 an inorganic electrolyte contained within the inorganic electrolyte reservoir,
 wherein lithium flows to the lithium anode from the lithium reservoir during charge and from the lithium anode to the lithium reservoir during recharge, the solid ceramic electrolyte conducts lithium ions from the lithium reservoir to the inorganic electrolyte for reaction with oxygen supplied by air flow to the air cathode, and wherein lithium oxygen reaction product is accumulated within the electrolyte reservoir.

36. The battery according to claim 35, wherein the lithium oxygen reaction product has at least limited solubility in the inorganic salt electrolyte.

37. A rechargeable lithium air battery comprising:
 a supply of air flow,
 a heat exchanger,
 a pump,
 a cathode,
 a temperature control system,
 a reaction chamber,
 a lithium reservoir,
 a molten salt electrolyte reservoir,
 a molten lithium anode contained in the lithium reservoir,
 and

15

a molten inorganic salt electrolyte contained within the molten salt electrolyte reservoir,
 wherein lithium is supplied to the reaction chamber from the lithium reservoir, molten inorganic salt is supplied to the reaction chamber from the molten salt electrolyte reservoir and air is supplied to the reaction chamber by the heat exchanger, the heat exchanger transfers heat from oxygen-depleted air leaving the cathode to ambient air flowing to the cathode, and wherein lithium oxygen reaction product accumulates within the molten salt electrolyte reservoir.

38. The battery according to claim 37, wherein the reaction chamber surrounds an air cathode and a solid ceramic lithium ion conductive electrolyte, wherein the solid ceramic lithium ion conductive electrolyte is coupled between the lithium reservoir and the molten inorganic salt electrolyte, isolating lithium from the molten inorganic salt electrolyte, interfacing lithium to the molten salt electrolyte or cathode, and conducting lithium ions from the lithium reservoir to the molten salt electrolyte for reaction with oxygen supplied to the cathode with air flow from the heat exchanger.

39. A rechargeable lithium air battery comprising:
 a supply of oxygen flow,
 a ceramic lithium ion conductive electrolyte,
 a pump,
 a lithium reservoir,
 an inorganic electrolyte reservoir,
 a molten lithium anode,
 a cathode, and
 an inorganic electrolyte contained within the electrolyte reservoir,
 wherein the ceramic electrolyte is coupled between the lithium anode and the cathode, lithium is supplied to the anode from the lithium reservoir, oxygen is supplied to the cathode, and lithium ions are conducted by the ceramic electrolyte to the cathode, whereby lithium reacts with oxygen at the cathode, the pump circulates the electrolyte between the cathode and the reservoir, and the electrolyte washes reaction product from the cathode during discharge and supplies reaction product to the cathode during recharge.

16

40. A rechargeable lithium air battery comprising:
 a supply of oxygen flow,
 a cathode,
 a ceramic lithium ion conductive electrolyte,
 a heat exchanger for transferring heat to air flowing to the cathode from air leaving the cathode,
 a lithium reservoir,
 an inorganic electrolyte reservoir,
 a molten lithium anode,
 a pump for supplying air to the cathode, and
 an inorganic electrolyte contained within the electrolyte reservoir,

wherein the ceramic electrolyte is coupled between the lithium anode and the cathode, lithium is supplied to the anode from the lithium reservoir, oxygen is supplied to cathode with air supplied by the pump, and lithium ions are conducted by the ceramic electrolyte to the cathode, whereby lithium reacts with oxygen at the cathode, and wherein lithium oxygen reaction product accumulates within the inorganic electrolyte reservoir.

41. A rechargeable lithium air battery comprising:
 a supply of air flow,
 an air cathode,
 an electrolyte pump,
 a temperature control system,
 a lithium ion conductive solid ceramic electrolyte
 a lithium reservoir,
 a molten salt electrolyte reservoir,
 a molten lithium anode contained in the lithium reservoir,
 and
 a molten inorganic salt electrolyte contained within the molten salt electrolyte reservoir,
 wherein the solid ceramic electrolyte conducts lithium ions from the lithium reservoir to the molten inorganic salt electrolyte for reaction with oxygen supplied by air flow to the cathode, and the electrolyte pump promotes electrolyte flow to contact the cathode and to remove and carry lithium oxygen reaction product to the electrolyte reservoir.

* * * * *