

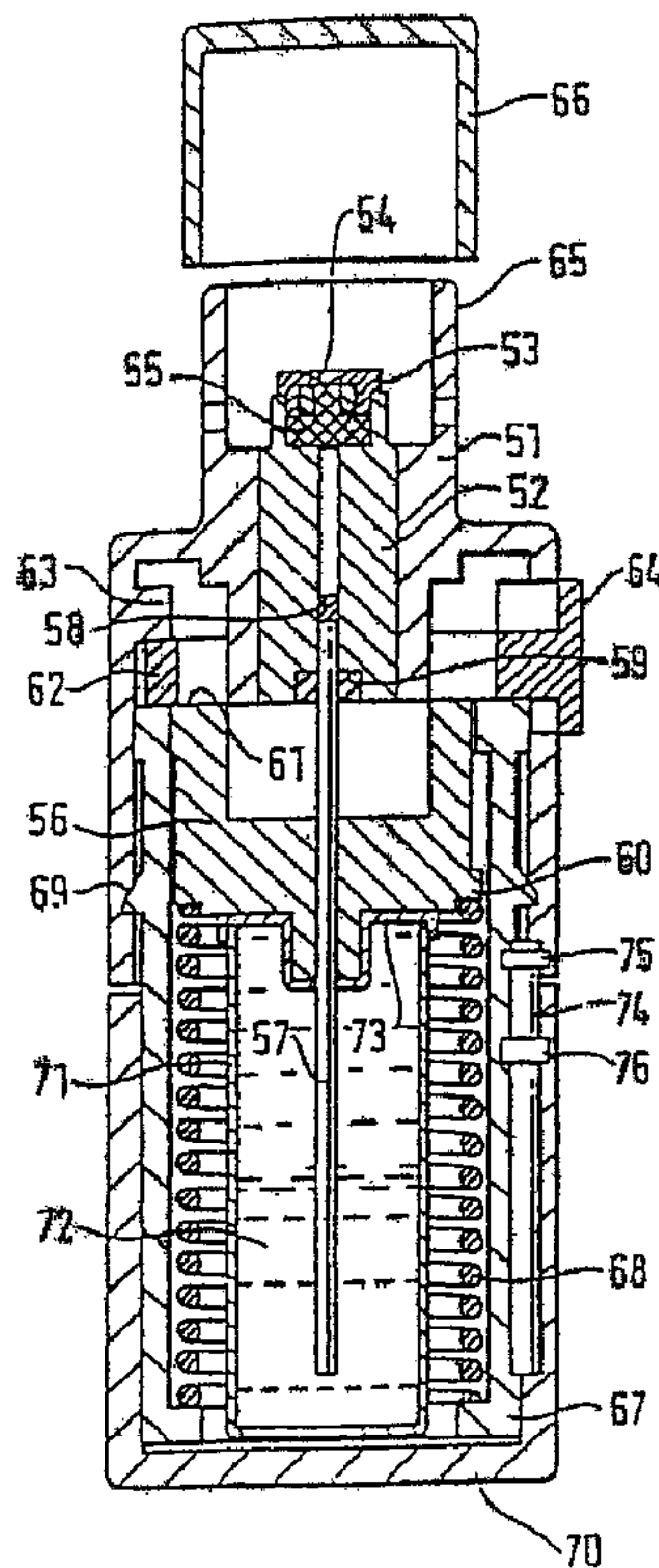

(22) Date de dépôt/Filing Date: 2001/10/23
 (41) Mise à la disp. pub./Open to Public Insp.: 2002/05/10
 (45) Date de délivrance/Issue Date: 2011/06/14
 (62) Demande originale/Original Application: 2 436 540
 (30) Priorités/Priorities: 2000/10/31 (DE100 54 042.2);
 2000/12/15 (DE100 62 712.9)

(51) Cl.Int./Int.Cl. *A61K 31/56* (2006.01),
A61K 31/46 (2006.01), *A61K 31/569* (2006.01),
A61K 31/573 (2006.01), *A61K 31/58* (2006.01),
A61K 9/12 (2006.01), *A61K 9/72* (2006.01),
A61P 11/00 (2006.01), *A61P 29/00* (2006.01)
 (72) Inventeurs/Inventors:
 PAIRET, MICHEL, DE;
 PIEPER, MICHAEL PAUL, DE;
 MEADE, CHRISTOPHER JOHN MONTAGUE, DE;
 REICHL, RICHARD, DE;
 SCHMELZER, CHRISTEL, DE
 (73) Propriétaire/Owner:

(54) Titre : COMPOSITIONS PHARMACEUTIQUES CONTENANT DES ANTICHOLINERGIQUES ET DES
 CORTICOSTEROIDES SOUS LA FORME D'UNE SUSPENSION OU D'UNE SOLUTION INHALABLE
 (54) Title: PHARMACEUTICAL COMPOSITIONS BASED ON ANTICHOLINERGICS AND CORTICOSTEROIDS IN THE
 FORM OF AN INHALABLE SOLUTION OR SUSPENSION



(57) Abrégé/Abstract:

The present invention relates to novel pharmaceutical compositions based on anticholinergics and corticosteroids, processes for preparing them and their use in the treatment of respiratory tract diseases. The pharmaceutical compositions are in the form of inhalable solutions or suspensions.

(73) Propriétaires(suite)/Owners(continued):BOEHRINGER INGELHEIM PHARMA GMBH & CO. KG, DE

(74) Agent: FETHERSTONHAUGH & CO.

25771-786D

Abstract

The present invention relates to novel pharmaceutical compositions based on anticholinergics and corticosteroids, processes for preparing them and their use in the treatment of respiratory tract diseases. The pharmaceutical compositions
5 are in the form of inhalable solutions or suspensions.

25771-786D

- 1a -

the pharmaceutical combinations according to the invention can be used in smaller doses than would be the case with the individual compounds used in monotherapy in the usual way. This reduces unwanted side effects such as may occur when
5 corticosteroids are administered, for example.

The effects mentioned above are observed both when the two active substances are administered simultaneously in a single active substance formulation and when they are administered successively in separate formulations.
10 According to the invention, it is preferable to administer the two active substance ingredients simultaneously in a single formulation.

25771-786D

- 2 -

Within the scope of the present invention the term anticholinergics 1 denotes salts which are preferably selected from among tiotropium salts, oxitropium salts and ipratropium salts, most preferably tiotropium salts.

5 In the above-mentioned salts the cations tiotropium, oxitropium and ipratropium are the pharmacologically active ingredients. Within the scope of the present patent application, an explicit reference to the above cations is indicated by the use of the number 1'. Any

10 reference to compounds 1 naturally also includes a reference to the ingredients 1' (tiotropium, oxitropium or ipratropium).

By the salts 1 which may be used within the scope of the present invention are meant the compounds which contain,

15 in addition to tiotropium, oxitropium or ipratropium as counter-ion (anion), chloride, bromide, iodide, sulphate, methanesulphonate or para-toluenesulphonate. Within the scope of the present invention, the methanesulphonate, chloride, bromide and iodide are preferred of all the

20 salts 1, the methanesulphonate and bromide being of particular importance. Of outstanding importance according to the invention are salts 1 selected from among tiotropium bromide, oxitropium bromide and ipratropium bromide. Tiotropium bromide is particularly

25 preferred.

Within the scope of the present invention, the word corticosteroids (hereinafter 2) denotes compounds selected from among flunisolide, beclomethasone, triamcinolone, budesonide, fluticasone, mometasone,

30 ciclesonide, rofleponide, GW 215864, KSR 592, ST-126 and dexamethasone. Preferably, compounds 2 is selected from among flunisolide, beclomethasone, triamcinolone, budesonide, fluticasone, mometasone, ciclesonide and dexamethasone. Most preferably, compound 2 is selected

25771-786D

- 3 -

from among budesonide, fluticasone, mometasone and ciclesonide. In some cases, within the scope of the present patent application, the term steroids 2 may also be used on its own instead of the word corticosteroids 2.

5 Any reference to steroids 2 within the scope of the present invention includes a reference to salts or derivatives 2' which may be formed from the steroids. Examples of possible salts or derivatives 2' include: sodium salts, sulphobenzoates, phosphates,
10 isonicotinates, acetates, propionates, dihydrogen phosphates, palmitates, pivalates or furoates. In some cases the compounds of formula 2 may also occur in the form of their hydrates.

The pharmaceutical combinations of 1 and 2 according to
15 the invention are preferably administered by inhalation. Suitable inhalable powders packed into suitable capsules (inhalettes) may be administered using suitable powder inhalers. Alternatively, the drug may be inhaled by the application of suitable inhalation aerosols. These
20 include inhalation aerosols which contain HFA134a, HFA227 or a mixture thereof as propellant gas. The drug may also be inhaled using suitable solutions of the pharmaceutical combination consisting of 1 and 2.

In one aspect, therefore, the invention relates to a
25 pharmaceutical composition which contains a combination of 1 and 2.

In another aspect the present invention relates to a pharmaceutical composition which contains one or more salts 1 and one or more compounds 2, optionally in the
30 form of their solvates or hydrates. The active substances may be combined in a single preparation or contained in two separate formulations. Pharmaceutical

25771-786D

- 4 -

compositions which contain the active substances 1 and 2 in a single preparation are preferred according to the invention.

In another aspect the present invention relates to a pharmaceutical composition which contains, in addition to therapeutically effective quantities of 1 and 2, a pharmaceutically acceptable excipient. In another aspect the present invention relates to a pharmaceutical composition which does not contain any pharmaceutically acceptable excipient in addition to therapeutically effective quantities of 1 and 2.

The present invention also relates to the use of 1 and 2 for preparing a pharmaceutical composition containing therapeutically effective quantities of 1 and 2 for treating inflammatory or obstructive diseases of the respiratory tract, particularly asthma or chronic obstructive pulmonary diseases (COPD) by simultaneous or successive administration. Moreover, the pharmaceutical combinations according to the invention may be used to prepare a drug for treating cystic fibrosis or allergic alveolitis (Farmer's Lung), for example, by simultaneous or successive administration. The only reason for not using the active substance combinations according to the invention is if treatment with steroids is contraindicated for therapeutic reasons.

According to one aspect of the invention of the parent application, there is provided a pharmaceutical composition in the form of an inhalable powder comprising (1) crystalline tiotropium bromide monohydrate and (2) one or more compounds selected from steroids, enantiomers

25771-786D

4a

thereof, mixtures of enantiomers, racemates thereof, solvates thereof and hydrates thereof.

According to another aspect of the invention of the parent application, there is provided use of crystalline tiotropium bromide monohydrate and component
5 (2) as defined herein in preparation of a pharmaceutical composition that is an inhalable powder for treating an inflammatory or obstructive disease of the respiratory tract.

According to one aspect of the invention of this divisional application, there is provided a pharmaceutical composition in the form of a propellant-containing
10 inhalable aerosol comprising an inhalable solution or suspension of a tiotropium salt (1) and one or more steroids (2), optionally in the form of enantiomers thereof, mixtures of the enantiomers thereof, racemates thereof, solvates thereof and hydrates thereof, wherein 1 and 2 in dissolved or suspended form.

According to another aspect of the invention of this divisional
15 application, the pharmaceutical composition described herein may be used for treating an inflammatory or obstructive disease of the respiratory tract.

The present invention further relates to the simultaneous or successive use of therapeutically effective doses of the combination of the above pharmaceutical compositions 1 and 2 for treating inflammatory or obstructive respiratory tract
20 diseases, particularly asthma or chronic obstructive pulmonary diseases (COPD), provided that treatment with steroids is not contraindicated for therapeutic reasons, by simultaneous or successive

25771-786D

- 5 -

administration. The present invention also relates to the simultaneous or successive use of therapeutically effective doses of the combination of the above pharmaceutical compositions 1 and 2 for treating cystic
5 fibrosis or allergic alveolitis (Farmer's Lung), for example.

In the active substance combinations of 1 and 2 according to the invention, ingredients 1 and 2 may be present in the form of their enantiomers, mixtures of enantiomers or
10 in the form of racemates.

The proportions in which the two active substances 1 and 2 may be used in the active substance combinations according to the invention are variable. Active substances 1 and 2 may possibly be present in the form of
15 their solvates or hydrates. Depending on the choice of the compounds 1 and 2, the weight ratios which may be used within the scope of the present invention vary on the basis of the different molecular weights of the various compounds and their different potencies. As a
20 rule, the pharmaceutical combinations according to the invention may contain compounds 1 and 2 in ratios by weight ranging from 1:300 to 50:1, preferably from 1:250 to 40:1. In the particularly preferred pharmaceutical combinations which contain tiotropium salt as compound 1
25 and a compound selected from among budesonide, fluticasone, mometasone and ciclesonide as the steroid 2, the weight ratios of 1 to 2 are most preferably in a range in which tiotropium 1' and 2 are present in proportions of 1:150 to 30:1, more preferably from 1:50
30 to 20:1.

For example, without restricting the scope of the invention thereto, preferred combinations of 1 and 2 according to the invention may contain 1' and steroid 2

25771-786D

- 6 -

in the following weight ratios: 1:50; 1:49; 1:48; 1:47;
 1:46; 1:45; 1:44; 1:43; 1:42; 1:41; 1:40; 1:39; 1:38;
 1:37; 1:36; 1:35; 1:34; 1:33; 1:32; 1:31; 1:30; 1:29;
 1:28; 1:27; 1:26; 1:25; 1:24; 1:23; 1:22; 1:21; 1:20;
 5 1:19; 1:18; 1:17; 1:16; 1:15; 1:14; 1:13; 1:12; 1:11;
 1:10; 1:9; 1:8; 1:7; 1:6; 1:5; 1:4; 1:3; 1:2; 1:1; 2:1;
 3:1; 4:1; 5:1; 6:1; 7:1; 8:1; 9:1; 10:1; 11:1; 12:1;
 13:1; 14:1; 15:1; 16:1; 17:1; 18:1; 19:1; 20:1.

The pharmaceutical compositions according to the
 10 invention containing the combinations of 1 and 2 are
 normally administered so that 1 and 2 are present
 together in doses of 0.01 to 10000 μ g, preferably from 0.1
 to 2000 μ g, more preferably from 1 to 1000 μ g, better still
 from 5 to 500 μ g, preferably, according to the invention,
 15 from 10 to 300 μ g, better still 20 to 200 μ g per single
 dose. For example, combinations of 1 and 2 according to
 the invention contain a quantity of tiotropium 1' and
 steroid 2 such that the total dosage per single dose is
 about 20 μ g, 25 μ g, 30 μ g, 35 μ g, 45 μ g, 50 μ g, 55 μ g, 60 μ g,
 20 65 μ g, 70 μ g, 75 μ g, 80 μ g, 85 μ g, 90 μ g, 95 μ g, 100 μ g, 105 μ g,
 110 μ g, 115 μ g, 120 μ g, 125 μ g, 130 μ g, 135 μ g, 140 μ g, 145 μ g,
 150 μ g, 155 μ g, 160 μ g, 165 μ g, 170 μ g, 175 μ g, 180 μ g, 185 μ g,
 190 μ g, 195 μ g, 200 μ g, 205 μ g, 210 μ g, 215 μ g, 220 μ g, 225 μ g,
 230 μ g, 235 μ g, 240 μ g, 245 μ g, 250 μ g, 255 μ g, 260 μ g, 265 μ g,
 25 270 μ g, 275 μ g or similar. In these dosage ranges, active
 substances 1' and 2 may be present in the weight ratios
 mentioned earlier.

For example, without restricting the scope of the
 invention thereto, the combinations of 1 and 2 according
 30 to the invention may contain a quantity of tiotropium 1'
 and steroid 2 such that, for each single dose, 5 μ g of 1'
 and 25 μ g of 2, 5 μ g of 1' and 50 μ g of 2, 5 μ g of 1' and
 100 μ g of 2, 5 μ g of 1' and 125 μ g of 2, 5 μ g of 1' and 200 μ g
 of 2, 5 μ g of 1' and 250 μ g of 2, 10 μ g of 1' and 25 μ g of 2,

25771-786D

- 7 -

10µg of 1' and 50µg of 2, 10µg of 1' and 100µg of 2, 10µg
 of 1' and 125µg of 2, 10µg of 1' and 200µg of 2, 10µg of
1' and 250µg of 2, 18µg of 1' and 25µg of 2, 18µg of 1'
 and 50µg of 2, 18µg of 1' and 100µg of 2, 18µg of 1' and
 5 125µg of 2, 18µg of 1' and 200µg of 2, 18µg of 1' and
 250µg of 2, 20µg of 1' and 25µg of 2, 20µg of 1' and 50µg
 of 2, 20µg of 1' and 100µg of 2, 20µg of 1' and 125µg of
2, 20µg of 1' and 200µg of 2, 20µg of 1' and 250µg of 2,
 36µg of 1' and 25µg of 2, 36µg of 1' and 50µg of 2, 36µg
 10 of 1' and 100µg of 2, 36µg of 1' and 125µg of 2, 36µg of
1' and 200µg of 2, 36µg of 1' and 250µg of 2, 40µg of 1'
 and 25µg of 2, 40µg of 1' and 50µg of 2, 40µg of 1' and
 100µg of 2, 40µg of 1' and 125µg of 2, 40µg of 1' and
 200µg of 2 or 40µg of 1' and 250µg of 2 are administered.

15 If the active substance combination in which 1 denotes
 tiotropium bromide is used as the preferred combination
 of 1 and 2 according to the invention, the quantities of
 active substance 1' and 2 administered per single dose
 mentioned by way of example correspond to the following
 20 quantities of 1 and 2 administered per single dose: 6µg
 of 1 and 25µg of 2, 6µg of 1 and 50µg of 2, 6µg of 1 and
 100µg of 2, 6µg of 1 and 125µg of 2, 6µg of 1 and 200µg
 of 2, 6µg of 1 and 250µg of 2, 12µg of 1 and 25µg of 2,
 12µg of 1 and 50µg of 2, 12µg of 1 and 100µg of 2, 12µg
 25 of 1 and 125µg of 2, 12µg of 1 and 200µg of 2, 12µg of 1
 and 250µg of 2, 21.7µg of 1 and 25µg of 2, 21.7µg of 1
 and 50µg of 2, 21.7µg of 1 and 100µg of 2, 21.7µg of 1
 and 125µg of 2, 21.7µg of 1 and 200µg of 2, 21.7µg of 1
 and 250µg of 2, 24.1µg of 1 and 25µg of 2, 24.1µg of 1
 30 and 50µg of 2, 24.1µg of 1 and 100µg of 2, 24.1µg of 1
 and 125µg of 2, 24.1µg of 1 and 200µg of 2, 24.1µg of 1
 and 250µg of 2, 43.3µg of 1 and 25µg of 2, 43.3µg of 1
 and 50µg of 2, 43.3µg of 1 and 100µg of 2, 43.3µg of 1
 and 125µg of 2, 43.3µg of 1 and 200µg of 2, 43.3µg of 1
 35 and 250µg of 2, 48.1µg of 1 and 25µg of 2, 48.1µg of 1

25771-786D

- 8 -

and 50 μ g of 2, 48.1 μ g of 1 and 100 μ g of 2, 48.1 μ g of 1
and 125 μ g of 2, 48.1 μ g of 1 and 200 μ g of 2 or 48.1 μ g of 1
and 250 μ g of 2.

If the active substance combination in which 1 is
5 tiotropium bromide monohydrate is used as the preferred
combination of 1 and 2 according to the invention, the
quantities of 1 and 2 administered per single dose
specified by way of example hereinbefore correspond to
the following quantities of 1 and 2 administered per
10 single dose: 6.2 μ g of 1 and 25 μ g of 2, 6.2 μ g of 1 and
50 μ g of 2, 6.2 μ g of 1 and 100 μ g of 2, 6.2 μ g of 1 and
125 μ g of 2, 6.2 μ g of 1 and 200 μ g of 2, 6.2 μ g of 1 and
250 μ g of 2, 12.5 μ g of 1 and 25 μ g of 2, 12.5 μ g of 1 and
50 μ g of 2, 12.5 μ g of 1 and 100 μ g of 2, 12.5 μ g of 1 and
15 125 μ g of 2, 12.5 μ g of 1 and 200 μ g of 2, 12.5 μ g of 1 and
250 μ g of 2, 22.5 μ g of 1 and 25 μ g of 2, 22.5 μ g of 1 and
50 μ g of 2, 22.5 μ g of 1 and 100 μ g of 2, 22.5 μ g of 1 and
125 μ g of 2, 22.5 μ g of 1 and 200 μ g of 2, 22.5 μ g of 1 and
250 μ g of 2, 25 μ g of 1 and 25 μ g of 2, 25 μ g of 1 and 50 μ g
20 of 2, 25 μ g of 1 and 100 μ g of 2, 25 μ g of 1 and 125 μ g of 2,
25 μ g of 1 and 200 μ g of 2, 25 μ g of 1 and 250 μ g of 2, 45 μ g
of 1 and 25 μ g of 2, 45 μ g of 1 and 50 μ g of 2, 45 μ g of 1
and 100 μ g of 2, 45 μ g of 1 and 125 μ g of 2, 45 μ g of 1 and
200 μ g of 2, 45 μ g of 1 and 250 μ g of 2, 50 μ g of 1 and 25 μ g
25 of 2, 50 μ g of 1 and 50 μ g of 2, 50 μ g of 1 and 100 μ g of 2,
50 μ g of 1 and 125 μ g of 2, 50 μ g of 1 and 200 μ g of 2 or
50 μ g of 1 and 250 μ g of 2.

The active substance combinations of 1 and 2 according to
the invention are preferably administered by inhalation.
30 For this purpose, ingredients 1 and 2 have to be made
available in forms suitable for inhalation. Inhalable
preparations include inhalable powders,
propellant-containing metering aerosols or
propellant-free inhalable solutions. Inhalable powders

25771-786D

- 9 -

according to the invention containing the combination of active substances 1 and 2 may consist of the active substances on their own or of a mixture of the active substances with physiologically acceptable excipients. Within the scope of the present invention, the term propellant-free inhalable solutions also includes concentrates or sterile inhalable solutions ready for use. The preparations according to the invention may contain the combination of active substances 1 and 2 either together in one formulation or in two separate formulations. These formulations which may be used within the scope of the present invention are described in more detail in the next part of the specification.

A) Inhalable powder containing the combinations of active substances 1 and 2 according to the invention:

The inhalable powders according to the invention may contain 1 and 2 either on their own or in admixture with suitable physiologically acceptable excipients.

If the active substances 1 and 2 are present in admixture with physiologically acceptable excipients, the following physiologically acceptable excipients may be used to prepare these inhalable powders according to the invention: monosaccharides (e.g. glucose or arabinose), disaccharides (e.g. lactose, saccharose, maltose), oligo- and polysaccharides (e.g. dextrane), polyalcohols (e.g. sorbitol, mannitol, xylitol), salts (e.g. sodium chloride, calcium carbonate) or mixtures of these excipients with one another. Preferably, mono- or disaccharides are used, while the use of lactose or glucose is preferred, particularly, but not exclusively, in the form of their hydrates. For the purposes of the invention, lactose is the particularly preferred excipient, while lactose monohydrate is most particularly preferred.

25771-786D

- 10 -

Within the scope of the inhalable powders according to the invention the excipients have a maximum average particle size of up to 250 μ m, preferably between 10 and 150 μ m, most preferably between 15 and 80 μ m. It may sometimes seem appropriate to add finer excipient fractions with an average particle size of 1 to 9 μ m to the excipient mentioned above. These finer excipients are also selected from the group of possible excipients listed hereinbefore. Finally, in order to prepare the inhalable powders according to the invention, micronised active substance 1 and 2, preferably with an average particle size of 0.5 to 10 μ m, more preferably from 1 to 5 μ m, is added to the excipient mixture. Processes for producing the inhalable powders according to the invention by grinding and micronising and by finally mixing the ingredients together are known from the prior art. The inhalable powders according to the invention may be prepared and administered either in the form of a single powder mixture which contains both 1 and 2 or in the form of separate inhalable powders which contain only 1 or 2.

The inhalable powders according to the invention may be administered using inhalers known from the prior art. Inhalable powders according to the invention which contain a physiologically acceptable excipient in addition to 1 and 2 may be administered, for example, by means of inhalers which deliver a single dose from a supply using a measuring chamber as described in US 4570630A, or by other means as described in DE 36 25 685 A. Preferably, the inhalable powders according to the invention which contain physiologically acceptable excipient in addition to 1 and 2 are packed into capsules (to produce so-called inhalettes) which are used in inhalers as described, for example, in WO 94/28958.

25771-786D

11

A particularly preferred inhaler for using the pharmaceutical combination according to the invention in inhalettes is shown in Figure 1.

This inhaler (Handihaler™) for inhaling powdered pharmaceutical compositions from capsules is
5 characterised by a housing 1 containing two windows 2, a deck 3 in which there are air inlet portions and which is provided with a screen 5 secured via a screen housing 4, an inhalation chamber 6 connected to the deck 3 on which
10 there is a push button 9 provided with two sharpened pins 7 and movable counter to a spring 8, and a mouthpiece 12 which is connected to the housing 1, the deck 3 and a cover 11 via a spindle 10 to enable it to be flipped open or shut.

15 If the inhalable powders according to the invention are packed into capsules (inhalers) for the preferred use described above, the quantities packed into each capsule should be 1 to 30mg, preferably 3 to 20mg, more particularly 5 to 10mg of inhalable powder per capsule.
20 These capsules contain, according to the invention, either together or separately, the doses of 1 and 2 mentioned hereinbefore for each single dose.

B) Propellant gas-driven inhalation aerosols containing the combinations of active substances 1 and 2:

25 Inhalation aerosols containing propellant gas according to the invention may contain substances 1 and 2 dissolved in the propellant gas or in dispersed form. 1 and 2 may be present in separate formulations or in a single preparation, in which 1 and 2 are either both dissolved,
30 both dispersed or only one component is dissolved and the other is dispersed. The propellant gases which may be used to prepare the inhalation aerosols according to the invention are known from the prior art. Suitable

25771-786D

- 12 -

propellant gases are selected from among hydrocarbons such as n-propane, n-butane or isobutane and halohydrocarbons such as fluorinated derivatives of methane, ethane, propane, butane, cyclopropane or cyclobutane. The propellant gases mentioned above may be used on their own or in mixtures thereof. Particularly preferred propellant gases are halogenated alkane derivatives selected from TG134a and TG227. Of the halogenated hydrocarbons mentioned above, TG134a (1,1,1,2-tetrafluoroethane) and TG227 (1,1,1,2,3,3,3-heptafluoropropane) and mixtures thereof are preferred according to the invention.

The propellant-driven inhalation aerosols according to the invention may also contain other ingredients such as co-solvents, stabilisers, surfactants, antioxidants, lubricants and pH adjusters. All these ingredients are known in the art.

The inhalation aerosols containing propellant gas according to the invention may contain up to 5 wt.-% of active substance 1 and/or 2. Aerosols according to the invention contain, for example, 0.002 to 5 wt.-%, 0.01 to 3 wt.-%, 0.015 to 2 wt.-%, 0.1 to 2 wt.-%, 0.5 to 2 wt.-% or 0.5 to 1 wt.-% of active substance 1 and/or 2.

If the active substances 1 and/or 2 are present in dispersed form, the particles of active substance preferably have an average particle size of up to 10µm, preferably from 0.1 to 5µm, more preferably from 1 to 5µm.

The propellant-driven inhalation aerosols according to the invention mentioned above may be administered using inhalers known in the art (MDIs = metered dose inhalers). Accordingly, in another aspect, the present invention

25771-786D

- 13 -

relates to pharmaceutical compositions in the form of propellant-driven aerosols as hereinbefore described combined with one or more inhalers suitable for administering these aerosols. In addition, the present invention relates to inhalers which are characterised in that they contain the propellant gas-containing aerosols described above according to the invention. The present invention also relates to cartridges which are fitted with a suitable valve and can be used in a suitable inhaler and which contain one of the above-mentioned propellant gas-containing inhalation aerosols according to the invention. Suitable cartridges and methods of filling these cartridges with the inhalable aerosols containing propellant gas according to the invention are known from the prior art.

C) Propellant-free inhalable solutions or suspensions containing the combinations of active substances 1 and 2 according to the invention:

It is particularly preferred to use the active substance combination according to the invention in the form of propellant-free inhalable solutions and suspensions. The solvent used may be an aqueous or alcoholic, preferably an ethanolic solution. The solvent may be water on its own or a mixture of water and ethanol. The relative proportion of ethanol compared with water is not limited but the maximum is up to 70 percent by volume, more particularly up to 60 percent by volume and most preferably up to 30 percent by volume. The remainder of the volume is made up of water. The solutions or suspensions containing 1 and 2, separately or together, are adjusted to a pH of 2 to 7, preferably 2 to 5, using suitable acids. The pH may be adjusted using acids selected from inorganic or organic acids. Examples of suitable inorganic acids include hydrochloric acid, hydrobromic acid, nitric acid, sulphuric acid and/or

25771-786D

- 14 -

phosphoric acid. Examples of particularly suitable organic acids include ascorbic acid, citric acid, malic acid, tartartic acid, maleic acid, succinic acid, fumaric acid, acetic acid, formic acid and/or propionic acid etc.

5 Preferred inorganic acids are hydrochloric and sulphuric acids. It is also possible to use the acids which have already formed an acid addition salt with one of the active substances. Of the organic acids, ascorbic acid, fumaric acid and citric acid are preferred. If desired,

10 mixtures of the above acids may be used, particularly in the case of acids which have other properties in addition to their acidifying qualities, e.g. as flavourings, antioxidants or complexing agents, such as citric acid or ascorbic acid, for example. According to the invention,

15 it is particularly preferred to use hydrochloric acid to adjust the pH.

According to the invention, the addition of editic acid (EDTA) or one of the known salts thereof, sodium editate, as stabiliser or complexing agent is unnecessary in the

20 present formulation. Other embodiments may contain this compound or these compounds. In a preferred embodiment the content based on sodium editate is less than 100mg/100ml, preferably less than 50mg/ml, more preferably less than 20mg/ml. Generally, inhalable

25 solutions in which the content of sodium editate is from 0 to 10mg/100ml are preferred.

Co-solvents and/or other excipients may be added to the propellant-free inhalable solutions according to the invention. Preferred co-solvents are those which contain

30 hydroxyl groups or other polar groups, e.g. alcohols - particularly isopropyl alcohol, glycols - particularly propyleneglycol, polyethyleneglycol, polypropyleneglycol, glycolether, glycerol, polyoxyethylene alcohols and polyoxyethylene fatty acid esters. The terms excipients

25771-786D

- 15 -

and additives in this context denote any pharmacologically acceptable substance which is not an active substance but which can be formulated with the active substance or substances in the pharmacologically suitable solvent in order to improve the qualitative properties of the active substance formulation. Preferably, these substances have no pharmacological effect or, in connection with the desired therapy, no appreciable or at least no undesirable pharmacological effect. The excipients and additives include, for example, surfactants such as soya lecithin, oleic acid, sorbitan esters, such as polysorbates, polyvinylpyrrolidone, other stabilisers, complexing agents, antioxidants and/or preservatives which guarantee or prolong the shelf life of the finished pharmaceutical formulation, flavourings, vitamins and/or other additives known in the art. The additives also include pharmacologically acceptable salts such as sodium chloride as isotonic agents.

20 The preferred excipients include antioxidants such as ascorbic acid, for example, provided that it has not already been used to adjust the pH, vitamin A, vitamin E, tocopherols and similar vitamins and provitamins occurring in the human body.

25 Preservatives may be used to protect the formulation from contamination with pathogens. Suitable preservatives are those which are known in the art, particularly cetyl pyridinium chloride, benzalkonium chloride or benzoic acid or benzoates such as sodium benzoate in the concentration known from the prior art. The preservatives mentioned above are preferably present in concentrations of up to 50mg/100ml, more preferably between 5 and 20mg/100ml.

25771-786D

- 16 -

Preferred formulations contain, in addition to the solvent water and the combination of active substances 1 and 2, only benzalkonium chloride and sodium edisylate. In another preferred embodiment, no sodium edisylate is present.

The propellant-free inhalable solutions according to the invention are administered in particular using inhalers of the kind which are capable of nebulising a small amount of a liquid formulation in the therapeutic dose within a few seconds to produce an aerosol suitable for therapeutic inhalation. Within the scope of the present invention, preferred inhalers are those in which a quantity of less than 100µL, preferably less than 50µL, more preferably between 10 and 30µL of active substance solution can be nebulised in preferably one spray action to form an aerosol with an average particle size of less than 20µm, preferably less than 10µm, in such a way that the inhalable part of the aerosol corresponds to the therapeutically effective quantity.

An apparatus of this kind for propellant-free delivery of a metered quantity of a liquid pharmaceutical composition for inhalation is described for example in International Patent Application WO 91/14468 and also in WO 97/12687 (cf. in particular Figures 6a and 6b). The nebulisers (devices) described therein are known by the name Respimat®.

This nebuliser (Respimat®) can advantageously be used to produce the inhalable aerosols according to the invention containing the combination of active substances 1 and 2. Because of its cylindrical shape and handy size of less than 9 to 15 cm long and 2 to 4 cm wide, this device can be carried at all times by the patient. The nebuliser sprays a defined volume of pharmaceutical formulation

25771-786D

- 17 -

using high pressures through small nozzles so as to produce inhalable aerosols.

The preferred atomiser essentially consists of an upper housing part, a pump housing, a nozzle, a locking mechanism, a spring housing, a spring and a storage container, characterised by

- a pump housing which is secured in the upper housing part and which comprises at one end a nozzle body with the nozzle or nozzle arrangement,
- 10 - a hollow plunger with valve body,
- a power takeoff flange in which the hollow plunger is secured and which is located in the upper housing part,
- a locking mechanism situated in the upper housing part,
- 15 - a spring housing with the spring contained therein, which is rotatably mounted on the upper housing part by means of a rotary bearing,
- a lower housing part which is fitted onto the spring housing in the axial direction.
- 20

The hollow plunger with valve body corresponds to a device disclosed in WO 97/12687. It projects partially into the cylinder of the pump housing and is axially movable within the cylinder. Reference is made in particular to Figures 1 to 4, especially Figure 3, and the relevant parts of the description. The hollow plunger with valve body exerts a pressure of 5 to 60 Mpa (about 50 to 600 bar), preferably 10 to 60 Mpa (about 100 to 600 bar) on the fluid, the measured amount of active substance solution, at its high pressure end at the moment when the spring is actuated. Volumes of 10 to 50 microlitres are preferred, while volumes of 10 to 20 microlitres are particularly preferred and a volume of 15 microlitres per spray is most particularly preferred.

25771-786D

- 18 -

The valve body is preferably mounted at the end of the hollow plunger facing the valve body.

The nozzle in the nozzle body is preferably microstructured, i.e. produced by microtechnology.

5 Microstructured valve bodies are disclosed for example in WO-94/07607; reference is hereby made to the contents of this specification, particularly Figure 1 therein and the associated description.

10 The valve body consists for example of two sheets of glass and/or silicon firmly joined together, at least one of which has one or more microstructured channels which connect the nozzle inlet end to the nozzle outlet end. At the nozzle outlet end there is at least one round or non-round opening 2 to 10 microns deep and 5 to 15
15 microns wide, the depth preferably being 4.5 to 6.5 microns while the length is preferably 7 to 9 microns.

In the case of a plurality of nozzle openings, preferably two, the directions of spraying of the nozzles in the nozzle body may extend parallel to one another or may be
20 inclined relative to one another in the direction of the nozzle opening. In a nozzle body with at least two nozzle openings at the outlet end the directions of spraying may be at an angle of 20 to 160° to one another, preferably 60 to 150°, most preferably 80 to 100°. The
25 nozzle openings are preferably arranged at a spacing of 10 to 200 microns, more preferably at a spacing of 10 to 100 microns, most preferably 30 to 70 microns. Spacings of 50 microns are most preferred. The directions of spraying will therefore meet in the vicinity of the
30 nozzle openings.

The liquid pharmaceutical preparation strikes the nozzle body with an entry pressure of up to 600 bar, preferably

25771-786D

- 19 -

200 to 300 bar, and is atomised into an inhalable aerosol through the nozzle openings. The preferred particle or droplet sizes of the aerosol are up to 20 microns, preferably 3 to 10 microns.

- 5 The locking mechanism contains a spring, preferably a cylindrical helical compression spring, as a store for the mechanical energy. The spring acts on the power takeoff flange as an actuating member the movement of which is determined by the position of a locking member.
- 10 The travel of the power takeoff flange is precisely limited by an upper and lower stop. The spring is preferably biased, via a power step-up gear, e.g. a helical thrust gear, by an external torque which is produced when the upper housing part is rotated counter
- 15 to the spring housing in the lower housing part. In this case, the upper housing part and the power takeoff flange have a single or multiple V-shaped gear.

The locking member with engaging locking surfaces is arranged in a ring around the power takeoff flange. It

20 consists, for example, of a ring of plastic or metal which is inherently radially elastically deformable. The ring is arranged in a plane at right angles to the atomiser axis. After the biasing of the spring, the locking surfaces of the locking member move into the path

25 of the power takeoff flange and prevent the spring from relaxing. The locking member is actuated by means of a button. The actuating button is connected or coupled to the locking member. In order to actuate the locking mechanism, the actuating button is moved parallel to the

30 annular plane, preferably into the atomiser; this causes the deformable ring to deform in the annual plane. Details of the construction of the locking mechanism are given in WO 97/20590.

25771-786D

- 20 -

The lower housing part is pushed axially over the spring housing and covers the mounting, the drive of the spindle and the storage container for the fluid.

When the atomiser is actuated the upper housing part is rotated relative to the lower housing part, the lower housing part taking the spring housing with it. The spring is thereby compressed and biased by means of the helical thrust gear and the locking mechanism engages automatically. The angle of rotation is preferably a whole-number fraction of 360 degrees, e.g. 180 degrees. At the same time as the spring is biased, the power takeoff part in the upper housing part is moved along by a given distance, the hollow plunger is withdrawn inside the cylinder in the pump housing, as a result of which some of the fluid is sucked out of the storage container and into the high pressure chamber in front of the nozzle.

If desired, a number of exchangeable storage containers which contain the fluid to be atomised may be pushed into the atomiser one after another and used in succession. The storage container contains the aqueous aerosol preparation according to the invention.

The atomising process is initiated by pressing gently on the actuating button. As a result, the locking mechanism opens up the path for the power takeoff member. The biased spring pushes the plunger into the cylinder of the pump housing. The fluid leaves the nozzle of the atomiser in atomised form.

Further details of construction are disclosed in PCT Applications WO 97/12683 and WO 97/20590, to which reference is hereby made.

25771-786D

- 21 -

The components of the atomiser (nebuliser) are made of a material which is suitable for its purpose. The housing of the atomiser and - if its operation permits, other parts as well are preferably made of plastics, e.g. by injection moulding. For medicinal purposes,
5 physiologically safe materials are used.

Figures 2a/b attached to this patent application, which are identical to Figures 6a/b of WO 97/12687, show the nebuliser (Respimat®) which can advantageously be used
10 for inhaling the aqueous aerosol preparations according to the invention.

Figure 2a shows a longitudinal section through the atomiser with the spring biased while Figure 2b shows a longitudinal section through the atomiser with the spring
15 relaxed.

The upper housing part (51) contains the pump housing (52) on the end of which is mounted the holder (53) for the atomiser nozzle. In the holder is the nozzle body (54) and a filter (55). The hollow plunger (57) fixed in
20 the power takeoff flange (56) of the locking mechanism projects partially into the cylinder of the pump housing. At its end the hollow plunger carries the valve body (58). The hollow plunger is sealed off by means of the seal (59). Inside the upper housing part is the stop
25 (60) on which the power takeoff flange abuts when the spring is relaxed. On the power takeoff flange is the stop (61) on which the power takeoff flange abuts when the spring is biased. After the biasing of the spring the locking member (62) moves between the stop (61) and a
30 support (63) in the upper housing part. The actuating button (64) is connected to the locking member. The upper housing part ends in the mouthpiece (65) and is

25771-786D

- 22 -

sealed off by means of the protective cover (66) which can be placed thereon.

The spring housing (67) with compression spring (68) is rotatably mounted on the upper housing part by means of the snap-in lugs (69) and rotary bearing. The lower housing part (70) is pushed over the spring housing. Inside the spring housing is the exchangeable storage container (71) for the fluid (72) which is to be atomised. The storage container is sealed off by the stopper (73) through which the hollow plunger projects into the storage container and is immersed at its end in the fluid (supply of active substance solution).

The spindle (74) for the mechanical counter is mounted in the covering of the spring housing. At the end of the spindle facing the upper housing part is the drive pinion (75). The slider (76) sits on the spindle.

The nebuliser described above is suitable for nebulising the aerosol preparations according to the invention to produce an aerosol suitable for inhalation.

If the formulation according to the invention is nebulised using the method described above (Respimat®) the quantity delivered should correspond to a defined quantity with a tolerance of not more than 25%, preferably 20% of this amount in at least 97%, preferably at least 98% of all operations of the inhaler (spray actuations). Preferably, between 5 and 30 mg of formulation, most preferably between 5 and 20 mg of formulation are delivered as a defined mass on each actuation.

However, the formulation according to the invention may also be nebulised by means of inhalers other than those

25771-786D

- 23 -

described above, e.g. jet stream inhalers or other stationary nebulisers.

Accordingly, in a further aspect, the invention relates to pharmaceutical formulations in the form of
5 propellant-free inhalable solutions or suspensions as described above combined with a device suitable for administering these formulations, preferably in conjunction with the Respimat®. Preferably, the invention relates to propellant-free inhalable solutions
10 or suspensions characterised by the combination of active substances 1 and 2 according to the invention in conjunction with the device known by the name Respimat®. In addition, the present invention relates to the above-mentioned devices for inhalation, preferably the
15 Respimat®, characterised in that they contain the propellant-free inhalable solutions or suspensions according to the invention as described hereinbefore.

The propellant-free inhalable solutions or suspensions according to the invention may take the form of
20 concentrates or sterile inhalable solutions or suspensions ready for use, as well as the above-mentioned solutions and suspensions designed for use in a Respimat®. Formulations ready for use may be produced from the concentrates, for example, by the addition of
25 isotonic saline solutions. Sterile formulations ready for use may be administered using energy-operated fixed or portable nebulisers which produce inhalable aerosols by means of ultrasound or compressed air by the Venturi principle or other principles.

30 Accordingly, in another aspect, the present invention relates to pharmaceutical compositions in the form of propellant-free inhalable solutions or suspensions as described hereinbefore which take the form of

25771-786D

- 24 -

concentrates or sterile formulations ready for use,
combined with a device suitable for administering these
solutions, characterised in that the device is an energy-
operated free-standing or portable nebuliser which
5 produces inhalable aerosols by means of ultrasound or
compressed air by the Venturi principle or other methods.

The Examples which follow serve to illustrate the present
invention in more detail without restricting the scope of
the invention to the following embodiments by way of
10 example.

Starting materials

Tiotropium bromide:

The tiotropium bromide used in the following formulations
examples may be obtained as described in European Patent
15 Application 418 716 A1.

In order to prepare the inhalable powders according to
the invention, crystalline tiotropium bromide monohydrate
may also be used. This crystalline tiotropium bromide
monohydrate may be obtained by the method described
20 below.

15.0 kg of tiotropium bromide are placed in 25.7 kg of
water in a suitable reaction vessel. The mixture is
heated to 80-90°C and stirred at constant temperature
until a clear solution is formed. Activated charcoal
25 (0.8 kg) moistened with water is suspended in 4.4 kg of
water, this mixture is added to the solution containing
the tiotropium bromide and the resulting mixture is
rinsed with 4.3 kg of water. The mixture thus obtained
is stirred for at least 15 minutes at 80-90°C and then
30 filtered through a heated filter into an apparatus
preheated to an external temperature of 70°C. The filter

25771-786D

- 25 -

is rinsed with 8.6 kg of water. The contents of the apparatus are cooled at 3-5°C for every 20 minutes to a temperature of 20-25°C. The apparatus is cooled further to 10-15°C using cold water and crystallisation is
5 completed by stirring for at least another hour. The crystals are isolated using a suction filter dryer, the crystal slurry isolated is washed with 9 litres of cold water (10-15°C) and cold acetone (10-15°C). The crystals obtained are dried at 25°C in a nitrogen current over a
10 period of 2 hours.

Yield: 13.4 kg of tiotropium bromide monohydrate (86% of theory).

The crystalline tiotropium bromide monohydrate thus obtained is micronised by known methods in order to
15 prepare the active substance in the form of the average particle size corresponding to the specifications according to the invention.

25771-786D

- 26 -

Examples of FormulationsA) Inhalable powders:

1)

Ingredients	µg per capsule
Tiotropium bromide	21.7
Budesonide	200
Lactose	4778.3
Total	5000

5

2)

Ingredients	µg per capsule
Tiotropium bromide	21.7
Fluticasone propionate	125
Lactose	4853.3
Total	5000

3)

Ingredients	µg per capsule
Tiotropium bromide x H ₂ O	22.5
Mometasone furoate	250
Lactose	4727.5
Total	5000

10 4)

Ingredients	µg per capsule
Tiotropium bromide	21.7
Ciclesonide	250
Lactose	4728.3
Total	5000

25771-786D

- 27 -

B) Propellant gas-containing aerosols for inhalation:

1) Suspension aerosol:

Ingredients	wt.-%
Tiotropium bromide	0.029
Budesonide	0.4
Soya lecithin	0.2
TG 134a: TG227 = 2:3	ad 100

5

2) Suspension aerosol:

Ingredients	wt.-%
Tiotropium bromide	0.029
Fluticasone-propionate	0.3
Isopropyl myristate	0.1
TG 227	ad 100

3) Suspension aerosol:

10

Ingredients	wt.-%
Tiotropium bromide	0.029
Mometasone-furoate	0.6
Isopropyl myristate	0.1
TG 227	ad 100

4) Suspension aerosol:

Ingredients	wt.-%
Tiotropium bromide	0.029
Ciclesonide	0.4
Isopropyl myristate	0.1
TG 227	ad 100

25771-786D

28

CLAIMS:

1. A pharmaceutical composition in the form of a propellant-containing inhalable aerosol comprising an inhalable solution or suspension of a tiotropium salt **(1)** and one or more steroids **(2)**, optionally in the form of enantiomers thereof,
5 mixtures of the enantiomers thereof, racemates thereof, solvates thereof and hydrates thereof, wherein **1** and **2** are in dissolved or suspended form.
2. A pharmaceutical composition according to claim 1, wherein **1** is present in the form of the chloride, bromide, iodide, methanesulphonate, sulphate or paratoluene sulphonate salt.
- 10 3. A pharmaceutical composition according to claim 1, wherein **1** is present in the form of the bromide salt.
4. A pharmaceutical composition according to claim 1, wherein **1** is present in the form of the bromide salt, monohydrate.
5. A pharmaceutical composition according to any one of claims 1 to 4,
15 wherein **2** is selected from among flunisolide, beclomethasone, triamcinolone, budesonide, fluticasone, mometasone, ciclesonide and dexamethasone.
6. A pharmaceutical composition according to any one of claims 1 to 4, wherein **2** is ciclesonide.
7. A pharmaceutical composition according to any one of claims 1 to 6,
20 wherein **1** and **2** are present in a weight ratio of from 1:300 to 50:1.
8. A pharmaceutical composition according to any one of claims 1 to 6, wherein **1** and **2** are present in a weight ratio of from 1:250 to 40:1.
9. A pharmaceutical composition according to any one of claims 1 to 8, wherein a single application corresponds to a dosage of the combination **1** and **2** of
25 0.1 to 10,000 µg.

25771-786D

29

10. A pharmaceutical composition according to any one of claims 1 to 8, wherein a single application corresponds to a dosage of the combination 1 and 2 of 0.1 to 2,000 µg.
11. A pharmaceutical composition according to any one of claims 1 to 10,
5 further comprising a pharmaceutically acceptable carrier or diluent.
12. A pharmaceutical composition according to any one of claims 1 to 11, wherein the propellant comprises a hydrocarbon or a halohydrocarbon.
13. A pharmaceutical composition according to claim 12, wherein the hydrocarbon is n-propane, n-butane or isobutane.
- 10 14. A pharmaceutical composition according to claim 12, wherein the halohydrocarbon is a fluorinated derivative of methane, ethane, propane, butane, cyclopropane or cyclobutane.
15. A pharmaceutical composition according to claim 12, wherein the propellant is TG134a, TG227 or a mixture thereof.
- 15 16. A pharmaceutical composition according to any one of claims 1 to 15, further comprising one or more other ingredients selected from the group consisting of cosolvents, stabilisers, surfactants, antioxidants, lubricants and means for adjusting the pH.
17. A pharmaceutical composition according to any one of claims 1 to 16
20 comprising up to 5% by weight of 1 and up to 5% by weight of 2.
18. A pharmaceutical composition as defined in any one of claims 1 to 17 for treating an inflammatory or obstructive disease of the respiratory tract.
19. A pharmaceutical composition as defined in any one of claims 1 to 17 for treatment of asthma.

25771-786D

30

20. A pharmaceutical composition as defined in any one of claims 1 to 17 for treatment of chronic obstructive pulmonary disease.
21. Use of a pharmaceutical composition as defined in any one of claims 1 to 17 for treating an inflammatory or obstructive disease of the respiratory tract.
- 5 22. Use of a pharmaceutical composition as defined in any one of claims 1 to 17 in preparation of a medicament for treating an inflammatory or obstructive disease of the respiratory tract.
23. Use of 1 and 2 in a pharmaceutical composition as defined in claim 1, 2, 3, 4, 5, 6, 7, 8, 9, 10, 11, 12, 13, 14, 15, 16 or 17 for treatment of asthma.
- 10 24. Use of 1 and 2 in a pharmaceutical composition as defined in claim 1, 2, 3, 4, 5, 6, 7, 8, 9, 10, 11, 12, 13, 14, 15, 16 or 17 for treatment of chronic obstructive pulmonary disease.

1/3

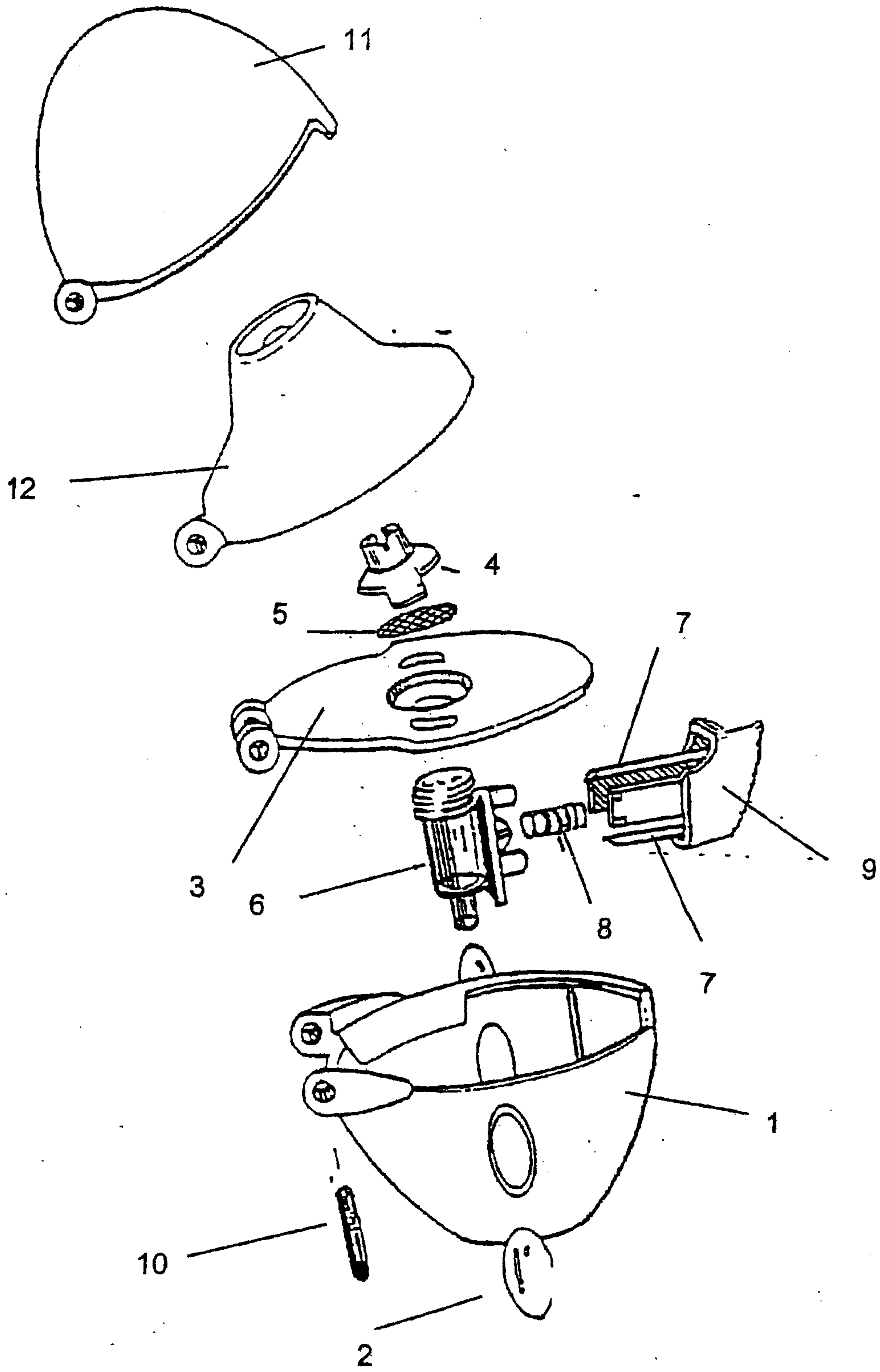

Fig. 1

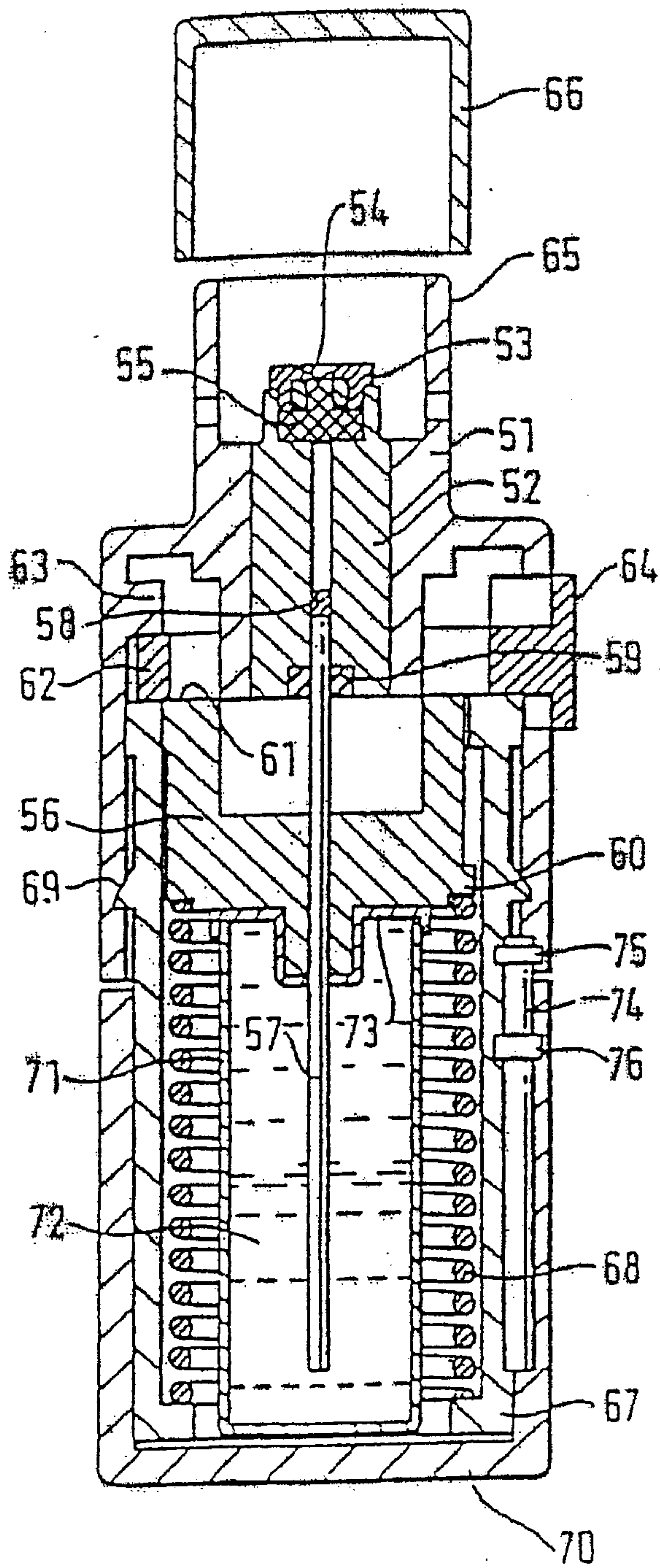

Fig. 2a

3/3

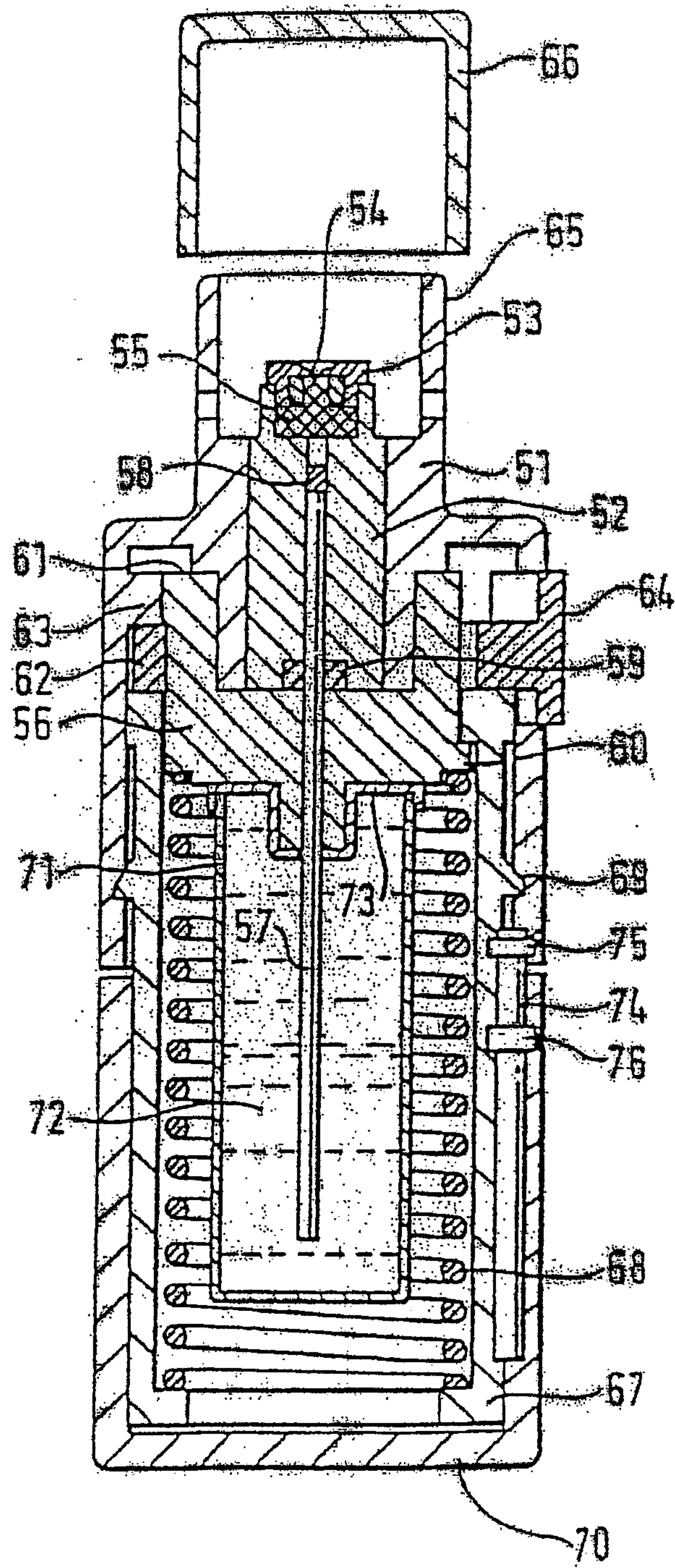

Fig. 2b

