



- (51) International Patent Classification:  
*F02P 9/00* (2006.01)     *H01T 13/38* (2006.01)  
*H01T 13/22* (2006.01)     *H01T 13/52* (2006.01)  
*H01T 13/34* (2006.01)
- (21) International Application Number:  
PCT/US2012/048423
- (22) International Filing Date:  
26 July 2012 (26.07.2012)
- (25) Filing Language: English
- (26) Publication Language: English
- (30) Priority Data:  
61/511,592     26 July 2011 (26.07.2011)     US
- (71) Applicant (for all designated States except US): **KNITE, INC.**, [US/US]; 18 West Piper Ave., Suite 2-1, Ewing, NJ 08628 (US).
- (72) Inventor; and
- (75) Inventor/Applicant (for US only): **SUCKEWER, Artur, P.**, [US/US]; 67 DeLeon Circle, Franklin Park, NJ 08823 (US).

- (74) Agent: **HENRY, Steven, J.**; Wolf, Greenfield & Sacks, P.C., 600 Atlantic Avenue, Boston, MA 02210-2206 (US).
- (81) Designated States (unless otherwise indicated, for every kind of national protection available): AE, AG, AL, AM, AO, AT, AU, AZ, BA, BB, BG, BH, BN, BR, BW, BY, BZ, CA, CH, CL, CN, CO, CR, CU, CZ, DE, DK, DM, DO, DZ, EC, EE, EG, ES, FI, GB, GD, GE, GH, GM, GT, HN, HR, HU, ID, IL, IN, IS, JP, KE, KG, KM, KN, KP, KR, KZ, LA, LC, LK, LR, LS, LT, LU, LY, MA, MD, ME, MG, MK, MN, MW, MX, MY, MZ, NA, NG, NI, NO, NZ, OM, PE, PG, PH, PL, PT, QA, RO, RS, RU, RW, SC, SD, SE, SG, SK, SL, SM, ST, SV, SY, TH, TJ, TM, TN, TR, TT, TZ, UA, UG, US, UZ, VC, VN, ZA, ZM, ZW.
- (84) Designated States (unless otherwise indicated, for every kind of regional protection available): ARIPO (BW, GH, GM, KE, LR, LS, MW, MZ, NA, RW, SD, SL, SZ, TZ, UG, ZM, ZW), Eurasian (AM, AZ, BY, KG, KZ, RU, TJ, TM), European (AL, AT, BE, BG, CH, CY, CZ, DE, DK, EE, ES, FI, FR, GB, GR, HR, HU, IE, IS, IT, LT, LU, LV, MC, MK, MT, NL, NO, PL, PT, RO, RS, SE, SI, SK, SM, TR), OAPI (BF, BJ, CF, CG, CI, CM, GA, GN, GQ, GW, ML, MR, NE, SN, TD, TG).

[Continued on next page]

(54) Title: TRAVELING SPARK IGNITER

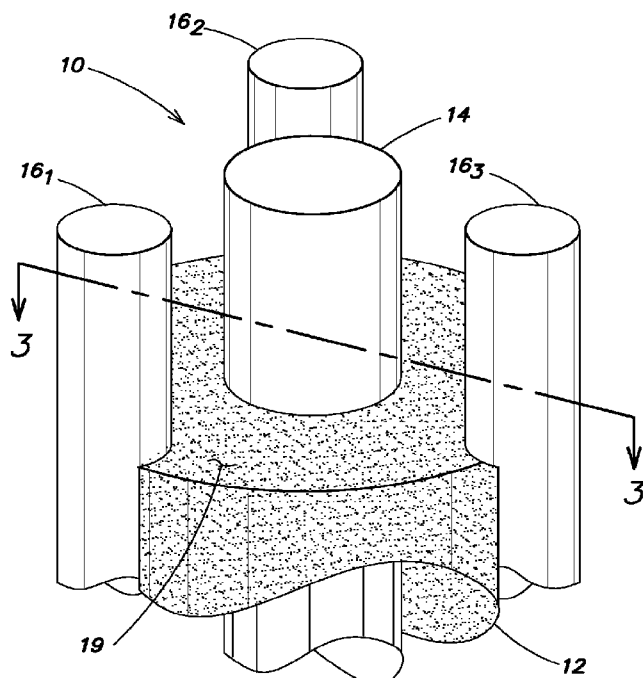

**FIG. 1A**

(57) Abstract: An igniter having at least two electrodes spaced from each other by an insulating member having a substantially continuous surface along a path between the electrodes. The electrodes extend substantially parallel to each other for a distance both above and below said surface. The insulating member has a channel (recess) for receiving at least a portion of a length of at least one of said electrodes below and to said surface of the insulating member. The surface of the insulating member may preferably be augmented with a conductivity enhancing agent. The insulating member and electrodes are configured so that an electric field between the electrodes at said surface does not have abrupt field intensity changes, whereby when a potential is applied to the electrodes sufficient to cause breakdown to occur between the electrodes, discharge occurs at said surface of the insulating member to define a plasma initiation region.

WO 2013/016592 A1



---

**Published:**

— with international search report (Art. 21(3))

— before the expiration of the time limit for amending the claims and to be republished in the event of receipt of amendments (Rule 48.2(h))

## TRAVELLING SPARK IGNITER

**CROSS-REFERENCE TO RELATED APPLICATIONS**

This application claims the benefit, under 35 USC 119(e), of U.S. Provisional Application No. 61/511,592, titled "TRAVELING SPARK IGNITER WITH ELECTRODES INSET IN INSULATOR," filed July 26, 2011, in the name of Artur P. Suckewer, Attorney Docket No. P0653.70023US00, which is hereby incorporated by reference in its entirety.

**BACKGROUND**

The traveling spark igniter (TSI) is a device that has been discussed as a promising spark plug replacement for internal combustion engines. TSIs have, for example, been shown in a number of prior patents. For example, U.S. Patents Nos. 5,704,321; 6,131,542; 6,321,733; 6,474,321; 6,662,793; 6,553,981; 7,467,612 and U.S. Patent Application No. 12/313,927 describe traveling spark ignition systems and igniters which employ Lorentz and thermal forces to propel a plasma into a combustion region (such as an engine chamber, where igniting a fuel-air mixture can be used to do useful work, or a burner for a furnace, for example). Those patents and application are hereby incorporated by reference in their entireties for their explanations of TSI devices and ignition systems.

Briefly, a TSI-based ignition system provides a plasma kernel which is propagated along the igniter's electrodes by Lorentz force (and grown with thermal forces) and subsequently, propelled into a combustion region. The Lorentz force acting on the ignition kernel (i.e., plasma) is created by way of the component of the discharge current passing through (or adjacent to) the plasma, between the electrodes, interacting with a magnetic field caused by a component of that same current in or along the electrodes of the igniter. The magnitude of the Lorentz force is proportional to the square of that current.

In engines operating at normal pressures (i.e., a maximum of about 120 psi at the time of ignition), traveling spark igniters provide significant advantages over conventional spark plugs due to the large plasma volume they generate, typically some 100-200 times larger than in a conventional spark plug, for comparable discharge energy. These advantages may include enabling increased efficiency and reduced emissions.

For higher engine operating pressures, however, the breakdown voltage required for initiating the discharge between the electrodes of the igniter is significantly higher than in

engines operating at conventional pressures. This creates problems for TSIs, as for any spark plug. The electrodes in a TSI, as in a conventional spark plug, are maintained in a spaced apart relationship by a member called an isolator, which is formed of an insulating material such as a ceramic. The higher breakdown voltage causes problems for both the isolator and the electrodes.

Along the surface of the isolator running between the electrodes, the breakdown voltage is lower than it is further along the electrodes in a TSI, or in any conventional spark plug with a similar gap between the electrodes. Indeed, this difference in breakdown voltages varies directly with increasing pressure at the location of the discharge. Consequently, although the breakdown voltage along the isolator surface increases with pressure, that increase is less than the increase in the breakdown voltage between the exposed part of the electrodes away from the isolator surface. When breakdown occurs (as a result of which the resistance through the plasma rapidly drops), the current rises rapidly and a very large current is conducted in the forming plasma at the isolator surface. The magnitude of the current may then fall over time, but the initial high current and the sustained current thereafter give rise to a Lorentz force acting on the plasma for a sufficient time to propel the plasma from the igniter into the combustion region. However, the power in the rapidly rising initial current creates not only a very high temperature plasma, but also a powerful shock wave in the vicinity of the surface of the isolator. The larger the current, the more rapid the plasma expansion and the resulting shock wave. These combined effects can cause deformation and/or breakage of the isolator.

As previously reported, for example, although both the railplug and the TSI generate significant plasma motion at relatively low pressures, when the combustion chamber pressure is increased to a high pressure, the plasma behaves differently and this difference in behavior leads to unsatisfactory results. In a low pressure environment, the force exerted on the plasma by the pressure is relatively small. The plasma remains diffuse and moves easily along the electrodes in response to the Lorentz force. As the ignition chamber pressure is increased, however, that pressure presents a force of significant magnitude that resists the Lorentz force and, thus, plasma motion. Consequently, the plasma tends to be or become more concentrated, and to collapse on itself; instead of having a diffused plasma cloud that is relatively easily moved, a very localized plasma – an arc – is formed between the electrodes and it is not easily propelled. This arc, though occupying a much smaller volume than the plasma cloud of the low-pressure case, receives similar energy. As a result, the current density is higher and at the electrodes, where the arc exists, there is a higher localized

temperature and more power density at the arc-electrode interfaces. Concurrently, the plasma, affected by the Lorentz and thermal forces, bows out from the arc attachment points. This causes the magnetic field lines to no longer be orthogonal to the current flow between the electrodes, reducing the magnitude of the Lorentz force produced by a given current. Should this occur, in addition to the other problems, there is a loss in motive force applied to the plasma at the plasma-electrode interface. Overall, there is a reduction in plasma motion as compared with the lower pressure environments, and dramatically increased electrode wear at the arc attachment points. Thus, railplug designs previously have not generally been useful over a wide range of engine pressures, from low to average to high pressures.

As opposed to conventional ignition systems, ignition systems which use electromagnetic fields to improve plasma/spark-based ignition systems generally attempt to create a relatively uniform electromagnetic field as localized field concentrations or other 'disturbances' may cause forces acting on the plasma and/or plasma propagations to occur in undesirable secondary directions (i.e., directions other than the direction it is desired to propel the plasma) or other secondary effects to occur. Once these 'disturbances' occur, especially if they are of sufficient magnitude, it is often found that the plasma will become 'unstable' as the disturbance often causes the plasma to become 'unaligned' with the field lines. Once this occurs, the plasma may exaggerate the disturbance in an inconsistent manner, causing the plasma to differ greatly in size, location of initial formation (breakdown), position and propagation direction between successive discharge events. This inconsistency in performance can detract from ignition system functional reliability, efficiency and effectiveness, as well as igniter lifetime (factors that are always important, even at low pressures, but some of which are particularly challenging in high pressure internal combustion engines).

Improvements are thus desired in plasma-based ignition systems with induced plasma motion, to improve the uniformity of formation and propulsion of the plasma, and other important operating parameters, over a wide range of engine pressures but especially in high pressure engines.

If a traveling spark igniter is to be used in a high pressure combustion environment, a need further exists to overcome the above negative effects on the isolator material and electrodes of the igniter. That is, a need exists for an igniter and ignition system for use in high pressure combustion engines, wherein the isolator and electrodes exhibit substantial lifetimes (preferably comparable to that of conventional spark plugs in low pressure engines) without being destroyed by the discharge process or environment. It has been observed that

TSI igniters wherein both electrodes are of a rail type configuration Lorentz force induced plasma motion is enhanced vs. a coaxial configuration Desirably, such a traveling spark igniter and ignition system will be usable and useful in internal combustion engines operating not only at high and very high pressures (i.e., hundreds of psi), but also at lower, conventional pressures, as well as in other combustion applications such as afterburners and augmentors.

## SUMMARY

An igniter satisfying the above needs is described and certain select, example embodiments are shown and discussed herein. It is not possible to show or discuss all of the many possible variations on the theme of illustrated device, of course.

According to a first aspect, an igniter embodying certain teachings mentioned herein has at least two electrodes spaced from each other by an insulating member which has a substantially continuous surface along a path between the electrodes. The electrodes preferably extend substantially parallel to each other for a distance both above and below said surface. The insulating member is shaped (e.g., molded or machined) with a channel or recess for receiving at least a portion of a length of at least one of said electrodes below and to said surface of the insulating member. That is, the at least one of said electrodes is inset into the insulator. (In certain embodiments, it may be desirable that the channel be larger than required to simply receive the inset electrode.) When a potential is applied to the electrodes sufficient to cause breakdown to occur between the electrodes, discharge occurs at said surface of the insulating member, which thus defines a plasma initiation region.

In some embodiments, the conductivity of said surface of the insulator may be enhanced. This enhancement can be achieved in a number of ways. For example, the surface of the insulator may be doped with a conductivity-enhancing agent using any known technique for doping the insulator material. In some embodiments, the insulator is made of a ceramic material and the conductivity enhancing agent is a metallic material. In other embodiments, said surface of the insulator is at least partially coated with a conductivity-enhancing agent, such as a metallic film, a solid element, engobe or paint.

In some embodiments of the above types, the electrodes comprise at least one inner electrode and at least one outer electrode, and the insulator has for each outer electrode a recess or channel running parallel to the inner electrode and sized to partially or fully receive a said outer electrode.

In some embodiments according to any of the foregoing, the substantially continuous surface may be a substantially flat surface.

According to another aspect, an igniter has at least two electrodes spaced from each other by an insulating member having a substantially continuous surface along a path between the electrodes, the electrodes extend substantially parallel to each other for a distance both above and below said surface, the surface of the insulating member has a conductivity enhancing agent and the insulating member and electrodes are configured so that an electric field between the electrodes at said surface does not have abrupt field intensity changes, whereby when a potential is applied to the electrodes sufficient to cause breakdown to occur between the electrodes, discharge occurs at said surface of the insulating member to define a plasma initiation region.

In some embodiments according to either aspect, the electrodes remain parallel for at least 0.010" below the initiation region; at least 0.020" below the initiation region; at least 0.040" below the initiation region; at least 0.080" below the initiation region; at least 0.160" below the initiation region; or at least 0.250" below the initiation region.

As in the first aspect, in some embodiments according to this aspect, the insulator may have its surface conductivity enhanced at the plasma initiation region. For example, said surface of the insulator may be doped with a conductivity-enhancing agent. Or, when the insulator is of a ceramic material, the conductivity enhancement may be achieved by doping with a metallic material. Or, the insulator may be at least partially coated with a conductivity-enhancing agent such as a metallic paint or engobe.

In some embodiments, the electrodes may comprise at least one inner electrode and at least one outer electrode, said electrodes being of substantially circular cross-section and the insulator has for each outer electrode a circular or partially circular channel running parallel to the inner electrode and sized to receive a said outer electrode.

In some embodiments, the electrodes comprise at least one inner electrode and at least one outer electrode, said electrodes being of substantially circular cross-section and the insulator has for each outer electrode a circular or partially circular channel running parallel to the inner electrode and sized to receive a said outer electrode. The electrodes may comprise at least one inner electrode and at least one outer electrode and be of substantially circular cross-section.

In any of the foregoing embodiments except for the coaxial embodiment, at least one of said electrodes may be larger in cross section above said surface of the insulating member than below said surface.

A still further aspect is an igniter having at least two electrodes spaced from each other by an insulating member having a surface (e.g., a semi-surface) at least partly filling a gap between the electrodes, the electrodes extending substantially parallel to each other for a distance both above and below said surface, the insulating member being shaped with a channel for receiving at least a portion of a length of at least one of said electrodes below and to said surface of the insulating member, whereby when a potential is applied to the electrodes sufficient to cause breakdown to occur between the electrodes, said surface of the insulating member defines a plasma initiation region.

### **BRIEF DESCRIPTION OF THE DRAWINGS**

Various aspects and embodiments of the application will be described with reference to the following figures. It should be appreciated that the figures are not necessarily drawn to scale. Items appearing in multiple figures are indicated by the same or a similar reference number in all the figures in which they appear.

FIG. 1A is an isometric, partially cut-away view of the tip region of a first example of a plasma-based igniter embodying some of the teachings expressed herein for constructing igniters which exhibit improved performance over a range of engine pressures, from normal to high;

FIG. 1B is an isometric, partially cut-away view of the tip region of a second example of a plasma-based igniter embodying some of the teachings expressed herein;

FIG. 2 is a top plan view of the end surface of isolator 18 or 18' of FIGS. 1A, 1B; and

FIG. 3 is a cross-sectional view of the isolator of the FIG. 1A embodiment, taken along section line 3-3 of FIG. 1A.

### **DETAILED DESCRIPTION**

As good as the igniters of the above-mentioned patents and application are, continuing efforts to improve these igniters have resulted in enhanced lifetimes and abilities to function in a wide range of engine pressure situations, particularly high engine pressure environments (i.e., those in which the pressure is at least approximately 120 psi at time of ignition, or more) as well as in other difficult and diverse combustion initiation situations. These positive results include the type of igniter embodiment shown in FIGS. 1 and 2.

Turning to those drawing figures, two examples are presented of igniters as taught herein. Each igniter, 10 and 10', respectively, comprises an isolator 12 or 12' having a central bore 13 which receives a center electrode 14 or 14' and one or more (i.e., N) outer electrodes 16<sub>1</sub>-16<sub>N</sub> or 16'<sub>1</sub>-16'<sub>N</sub>, respectively. Igniters 10 and 10' are identical except for the way isolators 12 and 12' are made, so only igniter 10 will be described initially. Then the difference between the two isolators will be discussed. In these examples, N=3, though one, two, three or more outer electrodes are feasible and the invention is not limited to a specific number of outer or inner (center) electrodes. (This is not meant to imply that the orientation of the electrodes need be circular. Other configurations are certainly acceptable.)

Preferably, each of the outer electrodes is shaped in cross-section to avoid creating sharp increases in field concentration in the area of minimum "radial" separation between the electrodes (i.e., the gap). More preferably, it is a smoothly curved surface at that point, considered from a longitudinal axis of the electrode (normal to the radial direction or the like in a non-circular configuration); and this curved surface (shown in the drawings as circular, but not necessarily so) is partially inset into, and bears against, a correspondingly curved (e.g., semicircular) groove or channel 18 (see Fig. 2) in isolator 12. The diameter of the outer electrode may differ above and below the initiation region. Any suitable construction (not shown) may be used to keep the outer electrodes in place, including, but not limited to, an insulating material encircling the illustrated apparatus or simply making the outer electrodes as part of a unitary outer structure for the igniter body.

Each of igniters 10 and 10' provides a defined plasma initiation region in the vicinity of the upper surface of its isolator. In the illustrated embodiments, the electrodes are approximately parallel extending away from the initiation region, with at least one outer electrode remaining approximately parallel to an inner electrode for a distance below the surface of the isolator (essentially an insulator) separating the electrodes. The electrodes preferably may remain parallel for at least 0.010" below the initiation region, for at least 0.020," for at least 0.040," for at least 0.080," for at least 0.160," or for at least 0.250" below the initiation region.

Embodiments are contemplated, also, in which the inner and outer electrodes may not be substantially parallel. For example, the surface of the outer or inner electrode(s) may tilt or curve away from the other electrode as a function of distance from the initiation region "outward" toward the combustion region. Or an outer electrode may exhibit a change in diameter along its length, which change may be either smooth or abrupt. For example, the diameter of an outer electrode might make a step change in the vicinity of the initiation

region. The change in diameter, whether smooth or abrupt might lead one to question whether such an electrode could ever be approximately or substantially parallel; however, it is intended that parallelism be assessed with reference to the axes of the electrodes, if they are substantially straight. In any event, these embodiments are within the teaching of this document as they still provide for an electric field that is free of significant abrupt changes along a path between the inner and outer electrodes in the vicinity of the initiation region.

The material forming the isolator preferably is a ceramic material, as in conventional spark plugs, but the surface region of the isolator may have its conductivity enhanced. This enhancement may be achieved in multiple ways, discussed below.

Avoiding sharp edges on the outer electrode(s) and inseting those electrodes into the insulating isolator, while maintaining a uniform spacing between inner and outer electrodes above and below the isolator surface is believed to reduce electric field concentrations and non-uniformities near the surface of the ceramic insulator, as compared to previous igniter designs of the type mentioned above, and to keep the overall electromagnetic fields correctly oriented both axially and radially (while likely compensating adequately for any intentionally introduced anomalies at the discharge initiation region – e.g., those caused by electrode diameter changes).

The plasma initiation region may be defined by a portion of the surface 19 of the insulator (isolator) 12 between the inner and outer electrodes. To reduce the voltage at which the arc discharge commences between the electrodes, and concomitantly reduce the amount of physical shock to the isolator when the breakdown occurs, the isolator material may be treated to reduce its resistivity somewhat from that of an untreated ceramic insulator material (such as aluminum oxide). Some example methods of reducing resistivity are discussed below.

The behavior of the electrical and magnetic fields in the region of the igniter/spark plug where the plasma is initially formed – i.e., the discharge initiation region - is important for forming and propelling the plasma. However, the discharge initiation region presents a challenge. A commercially useful igniter must meet a difficult set of requirements, including promoting consistent and reliable plasma formation with each firing, at a consistent initiation region; generating a sufficient and consistent Lorentz force to drive the plasma in the desired direction, even in high pressure engines; and exhibiting long life.

Others who have worked on improving railplugs have tried to accomplish similar objects by narrowing the gap between the electrodes (“rails”) in order to define the discharge initiation region. This approach has been found to affect the local electromagnetic properties

sufficiently as to distort the electromagnetic field locally to inhibit motion of the locus of the electrode plasma interface thus stressing the electrode material, such that the electrode material is distorted or displaced. This distortion/displacement leads to two forms of reliability issues: (1) the igniter 'wears out' due to material displacement/loss, and (2) the igniter fails to produce a consistently repeatable plasma. That happens because the required breakdown potential changes due to the local geometry at the discharge initiation region changing, which is at least partly due to electrode material distortion/displacement.

By contrast, as taught herein the discharge initiation region is created by providing at the desired location for that region a physical structure that, locally, reduces the potential necessary to achieve a breakdown in the gap between the inner and outer electrodes while minimizing the disturbance to the field when viewed in its totality. That physical structure typically is a surface of an insulator, the isolator that separates the inner and outer electrodes.

This technique allows for better control of the discharge initiation and generally improved reliability/longevity over the previously discussed railplug improvements. However, it has its own challenges, including higher stress on the ceramic insulator and changes in breakdown potential and in 'functional geometry' due to deposits of electrode material forming on the ceramic surface at or near the discharge region. As previously reported, one way of addressing some of these issues is by using a ceramic insulator having an upper surface that does not extend the entire distance between the electrodes – i.e., it is depressed, or dips, over part of that distance. This is referred to as a semi-surface discharge gap. Normally (but not always), the depression is near the cathode; thus, the discharge consistently starts at the ceramic surface at the anode (or first electrode). However, due to the gap, or dip, in the ceramic surface, between the electrodes, the termination point of the discharge on the surface of the cathode (second electrode) will normally vary over a greater region than on the anode (first electrode). This approach is particularly useful to permit an increase in the energy used during plasma initiation. However, the dip, a non-uniformity, in the isolator surface also introduces a complication, as it works at cross purposes with a desire to consistently initiate the plasma formation in a specific, localized region of the discharge zone of the igniter. With elongated inner and outer electrodes, sometimes called rails, as the potential builds prior to breakdown, the dielectric gains a charge, thus altering the electromagnetic fields during discharge, especially in the first moments of plasma and arc formation. Thus, a ceramic/electrode interface that is not substantially uniform across the majority of the interface creates inconsistencies in the field.

Instead, of using the dip, the “upper” surface 19 (or 19’) of the isolator 12 (or 12’) is substantially uniform and flat. A top view of the upper surface of the isolator, shown in FIG. 2, further illustrates that point, as well as showing the formation of channels 18 and bore 13 for receiving the outer electrodes and inner electrode, respectively. This situation is further shown in the cross-sectional view of the isolator as presented in Fig. 3. There, only one channel 18 is indicated since section line 3-3 cuts only one outer electrode and its channel.

To facilitate a reduction in the breakdown voltage for some embodiments, the isolator dielectric, or at least its surface, may be treated with materials, or have materials added to or placed at the surface, that allow a region at the portion of the surface of the dielectric at or near the discharge initiation region to act in a more conductive manner than would a pure nonconductive ceramic by itself. This approach allows for use of a lower voltage (potential), and usually less energy, to cause breakover/breakdown of the discharge initiation region and formation of the initial arc that supports the current which gives rise to the Lorentz force. This is particularly useful for applications in high pressure engines. Lower pressure engines may not require the isolator to be anything other than a plain ceramic.

As a first example of the conductivity-enhanced isolator, dopants such as platinum (delivered to the ceramic – e.g., alumina - while in a partially sintered state - via Chloroplatinic acid or Hydrogen hexachloroplatinate) and other metals have been shown to have beneficial significant effects. For example, as shown in FIG. 1A and indicated by the stippling of isolator 12 therein, one embodiment of a suitable structure may be produced by molding and partially sintering a powdered ceramic material such as alumina into a partially completed isolator, stopping the sintering process at a suitable point such as only about 25-30% of the total sintering time; doping the partially sintered isolator “blank” by exposing the blank to a solution of a powdered dopant in a liquid carrier such as those just mentioned, for an empirically determined appropriate time interval sufficient for the isolator to “wick” up a quantity of the dopant; removing the doped isolator from the solution and completing the temperature treatment required to finish the sintering process. Doping the ceramic in this way reduces the breakdown voltage of the igniter by about thirty to fifty percent and, in turn, reduces the wear on, and extends the life of, the igniter.

While FIGS. 1A and 3 might be thought to suggest that the doping of the isolator is uniform (at least in the vicinity of the electrodes and initiation region), no such inference is intended. It is believed to be sufficient if the doping merely penetrates the isolator surface to a small depth at the initiation region and adjacent the electrodes.

The use of round cross-section electrodes and insetting the outer electrodes in round, semicircular channels in the insulator helps to orient the electromagnetic fields at the initiation region and to minimize electric field concentrations (i.e., non-uniformities) of the kind that lead to the undesirable effects mentioned above.

A second example of an embodiment that also enhances the conductivity of the isolator in the initiation region is shown in FIG. 1B. There, the isolator 12' is an undoped ceramic material. However, the surface of the isolator has been enhanced by the application of a very thin layer of a relatively conductive material. That material may be, for example, a metallic (e.g., gold) layer, brushed on as a paint, sprayed on, or applied through vapor deposition or other techniques. Of course, those skilled in the art understand that there are many other ways of creating an isolator with a conductivity-enhanced surface. However the conductivity enhancement is achieved, it preferably will not introduce any significant electric field non-uniformities in a path between inner and outer electrodes.

The insetting of the outer electrodes into the sides of the isolator also helps to avoid localized concentrations of the electric field so that such field is reasonably uniform at the moment of discharge initiation. This contributes to uniform, consistent and repeatable plasma formation.

In addition to the embodiments illustrated, which are examples only, it will be appreciated by those skilled in the art that other electrode structures can be used to achieve similar operation

Any of the above features may be intermixed with other features in any desired arrangement, so long as they are not mutually exclusive.

While the invention has been described with respect to a limited number of embodiments, those skilled in the art, having benefit of this disclosure, will appreciate that other embodiments can be devised within the spirit and scope of the invention as disclosed herein. Accordingly, the scope of the invention should be limited only by the attached claims.

What is claimed is:

## CLAIMS

1. An igniter having at least two electrodes spaced from each other by an insulating member having a substantially continuous surface along a path between the electrodes, the electrodes extending substantially parallel to each other for a distance both above and below said surface, the insulating member being shaped with a channel for receiving at least a portion of a length of at least one of said electrodes below and to said surface of the insulating member, whereby when a potential is applied to the electrodes sufficient to cause breakdown to occur between the electrodes, said surface of the insulating member defines a plasma initiation region.
2. The igniter of claim 1, wherein said surface of the insulator is doped with a conductivity-enhancing agent.
3. The igniter of claim 2, wherein the insulator is of a ceramic material and the conductivity enhancing agent is a metallic material.
4. The igniter of claim 1 wherein said surface of the insulator is at least partially coated with a conductivity-enhancing agent.
5. The igniter of any of claims 1-4 wherein the electrodes comprise at least one inner electrode and at least one outer electrode, and the insulator has for each outer electrode a recessed channel running parallel to the inner electrode and sized to partially or fully receive a said outer electrode.
6. The igniter of claim 1, wherein the substantially continuous surface is a substantially flat surface.

7. An igniter having at least two electrodes spaced from each other by an insulating member having a substantially continuous surface along a path between the electrodes, the electrodes extending substantially parallel to each other for a distance both above and below said surface, the surface of the insulating member having a conductivity enhancing agent and the insulating member and electrodes being configured so that an electric field between the electrodes at said surface does not have abrupt field intensity changes, whereby when a potential is applied to the electrodes sufficient to cause breakdown to occur between the electrodes, discharge occurs at said surface of the insulating member to define a plasma initiation region.
8. The igniter of claim 1 or claim 7 wherein the electrodes remain parallel for at least 0.010" below the initiation region.
9. The igniter of claim 1 or claim 7 wherein the electrodes remain parallel for at least 0.020" below the initiation region.
10. The igniter of claim 1 or claim 7 wherein the electrodes remain parallel for at least 0.040" below the initiation region.
11. The igniter of claim 1 or claim 7 wherein the electrodes remain parallel for at least 0.080" below the initiation region
12. The igniter of claim 1 or claim 7 wherein the electrodes remain parallel for at least 0.160" below the initiation region.
13. The igniter of claim 12, wherein said surface of the insulator is doped with a conductivity-enhancing agent.
14. The igniter of claim 12, wherein the insulator is of a ceramic material and the conductivity enhancing agent is a metallic material.
15. The igniter of claim 12 wherein said surface of the insulator is at least partially coated with a conductivity-enhancing agent.

16. The igniter of claim 13 wherein the electrodes comprise at least one inner electrode and at least one outer electrode, said electrodes being of substantially circular cross-section and the insulator has for each outer electrode a circular or partially circular channel running parallel to the inner electrode and sized to receive a said outer electrode.
17. The igniter of claim 14 wherein the electrodes comprise at least one inner electrode and at least one outer electrode, said electrodes being of substantially circular cross-section and the insulator has for each outer electrode a circular or partially circular channel running parallel to the inner electrode and sized to receive a said outer electrode.
18. The igniter of claim 15 wherein the electrodes comprise at least one inner electrode and at least one outer electrode, said electrodes being of substantially circular cross-section and the insulator has for each outer electrode a circular or partially circular channel running parallel to the inner electrode and sized to receive a said outer electrode.
19. The igniter of claim 7 wherein one of the electrodes is a cylinder coaxially oriented around the other electrode.
20. The igniter of claim 5, wherein at least one of said electrodes is larger in cross section above said surface of the insulating member than below said surface.
21. The igniter of claim 7, wherein at least one of said electrodes is larger in cross section above said surface of the insulating member than below said surface.
22. The igniter of claim 1 or claim 7 wherein the electrodes remain parallel for at least 0.250" below the initiation region.
23. The igniter of claim 1 wherein the channel is larger than is required to receive an electrode therein.
24. An igniter having at least two electrodes spaced from each other by an insulating member having a surface at least partly filling a gap between the electrodes, the electrodes extending substantially parallel to each other for a distance both above and below said surface, the insulating member being shaped with a channel for receiving at least a portion of

a length of at least one of said electrodes below and to said surface of the insulating member, whereby when a potential is applied to the electrodes sufficient to cause breakdown to occur between the electrodes, said surface of the insulating member defines a plasma initiation region.

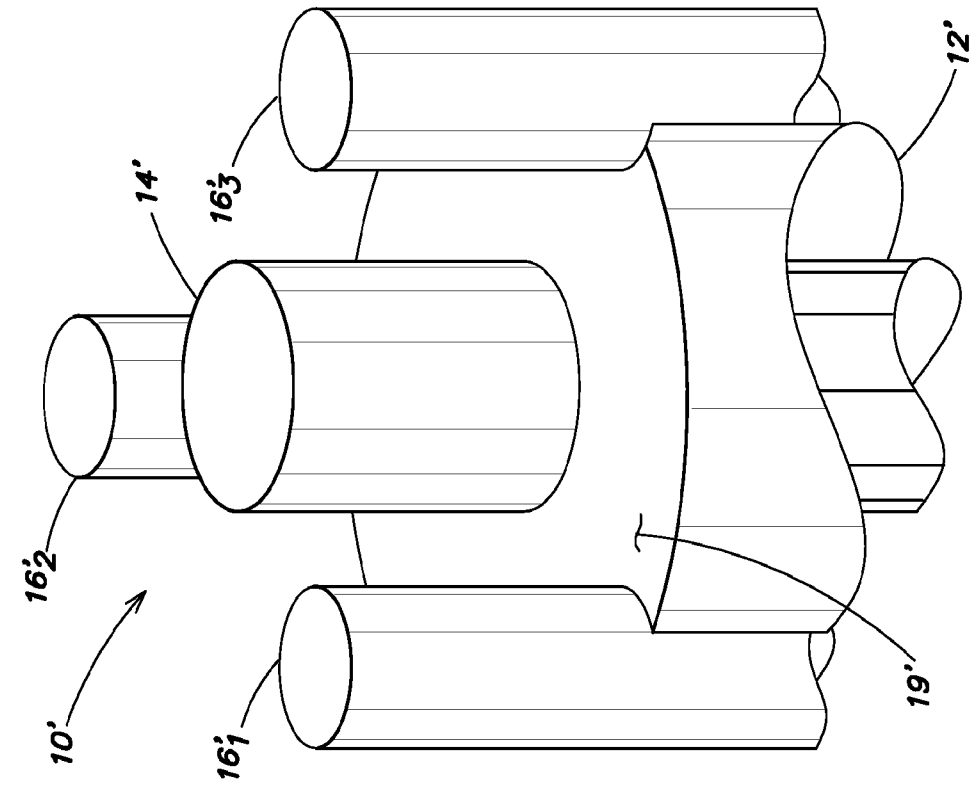

**FIG. 1B**

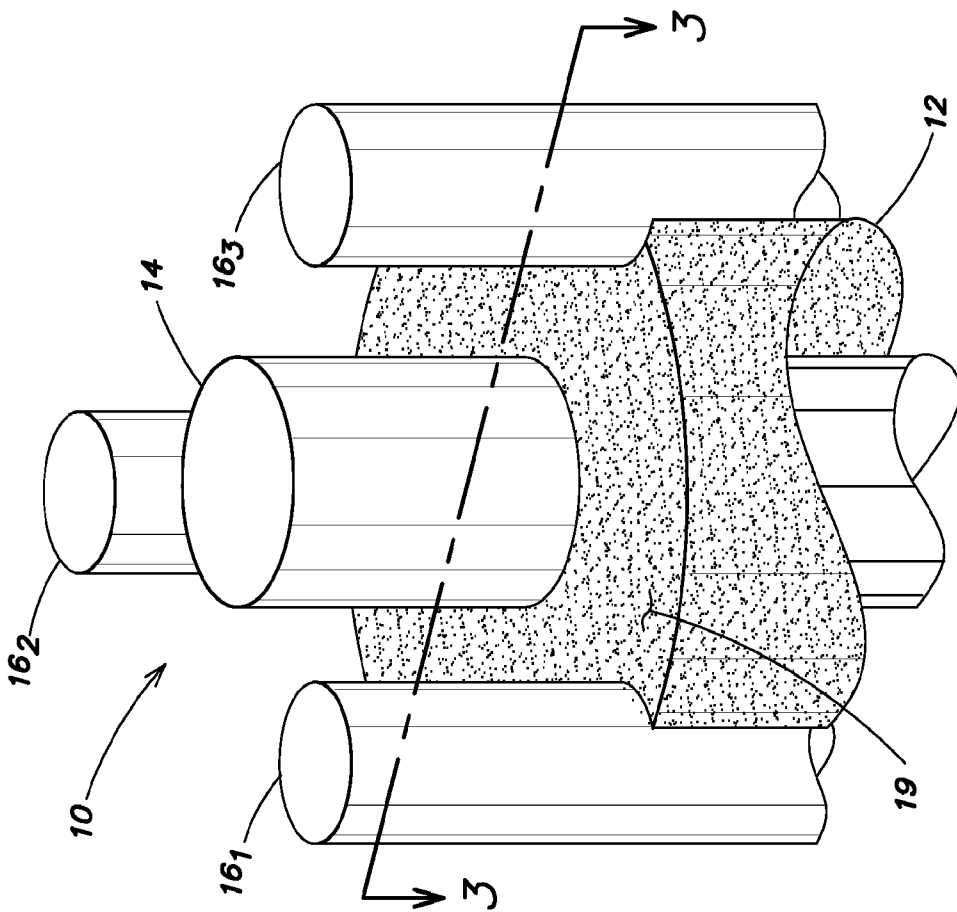

**FIG. 1A**

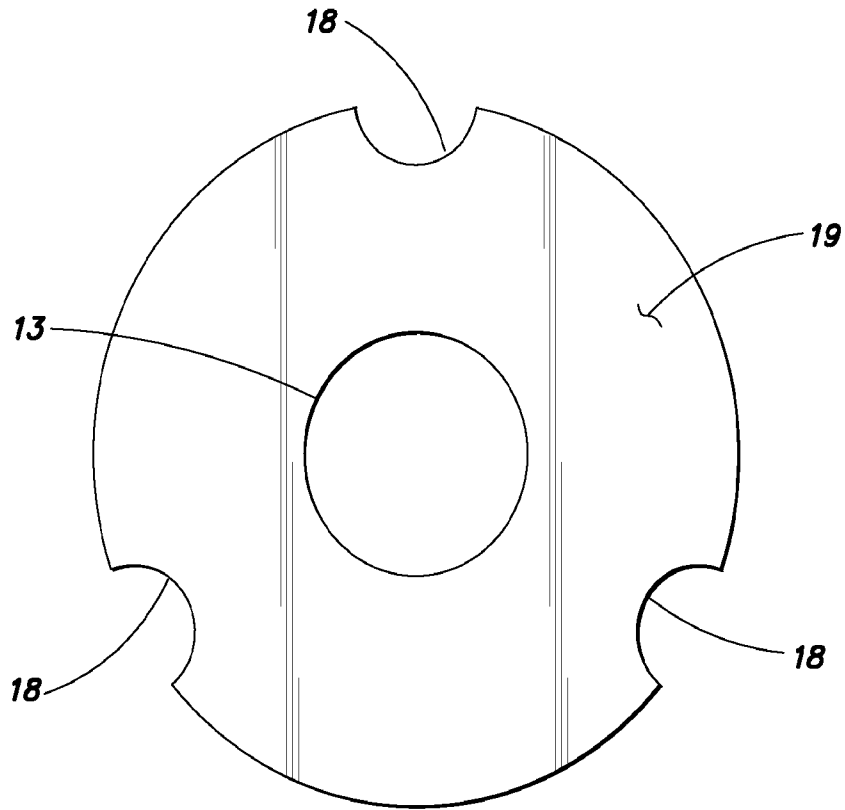

**FIG. 2**

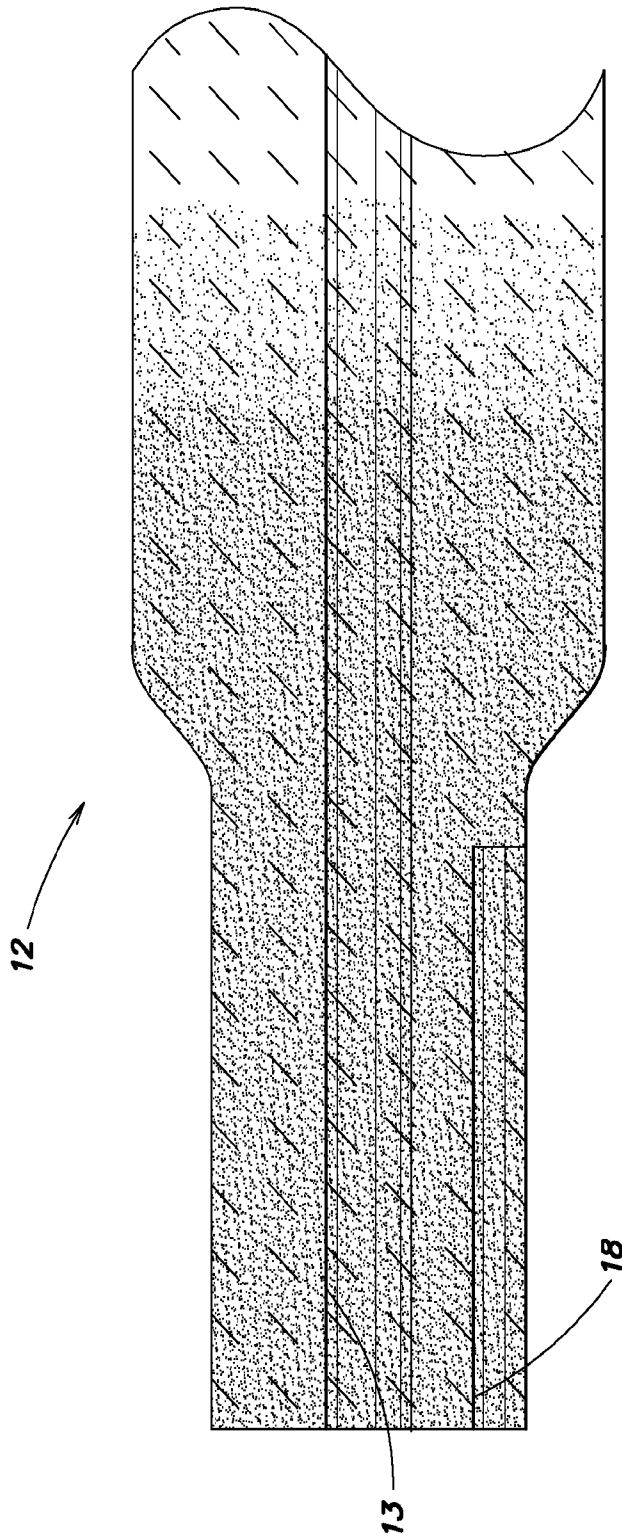

**FIG. 3**

# INTERNATIONAL SEARCH REPORT

International application No PCT/US2012/048423
---

<b>A. CLASSIFICATION OF SUBJECT MATTER</b> INV. F02P9/00      H01T13/22      H01T13/34      H01T13/38      H01T13/52 ADD.				
According to International Patent Classification (IPC) or to both national classification and IPC				
<b>B. FIELDS SEARCHED</b>				
Minimum documentation searched (classification system followed by classification symbols) F02P H01T				
Documentation searched other than minimum documentation to the extent that such documents are included in the fields searched				
Electronic data base consulted during the international search (name of data base and, where practicable, search terms used) EPO-Internal, WPI Data				
<b>C. DOCUMENTS CONSIDERED TO BE RELEVANT</b>				
Category*	Citation of document, with indication, where appropriate, of the relevant passages	Relevant to claim No.		
X	US 5 564 403 A (CODINA GEORGE [US] ET AL) 15 October 1996 (1996-10-15) the whole document -----	1		
X	WO 88/04729 A1 (CUMBUSTION ELECTROMAGNETICS [US]) 30 June 1988 (1988-06-30) the whole document -----	1		
X	US 4 795 937 A (WAGNER EBERHARD P [DE] ET AL) 3 January 1989 (1989-01-03) the whole document -----	1-21,23, 24		
X	WO 2009/105273 A1 (EHRlich MELVIN [US]) 27 August 2009 (2009-08-27) the whole document -----	1-4,6, 8-15,23		
----- -/--				
<input checked="" type="checkbox"/> Further documents are listed in the continuation of Box C. <input checked="" type="checkbox"/> See patent family annex.				
* Special categories of cited documents : <table style="width: 100%; border: none;"> <tr> <td style="width: 50%; border: none; vertical-align: top;">                     "A" document defining the general state of the art which is not considered to be of particular relevance                      "E" earlier application or patent but published on or after the international filing date                      "L" document which may throw doubts on priority claim(s) or which is cited to establish the publication date of another citation or other special reason (as specified)                      "O" document referring to an oral disclosure, use, exhibition or other means                      "P" document published prior to the international filing date but later than the priority date claimed                 </td> <td style="width: 50%; border: none; vertical-align: top;">                     "T" later document published after the international filing date or priority date and not in conflict with the application but cited to understand the principle or theory underlying the invention                      "X" document of particular relevance; the claimed invention cannot be considered novel or cannot be considered to involve an inventive step when the document is taken alone                      "Y" document of particular relevance; the claimed invention cannot be considered to involve an inventive step when the document is combined with one or more other such documents, such combination being obvious to a person skilled in the art                      "&amp;" document member of the same patent family                 </td> </tr> </table>			"A" document defining the general state of the art which is not considered to be of particular relevance "E" earlier application or patent but published on or after the international filing date "L" document which may throw doubts on priority claim(s) or which is cited to establish the publication date of another citation or other special reason (as specified) "O" document referring to an oral disclosure, use, exhibition or other means "P" document published prior to the international filing date but later than the priority date claimed	"T" later document published after the international filing date or priority date and not in conflict with the application but cited to understand the principle or theory underlying the invention "X" document of particular relevance; the claimed invention cannot be considered novel or cannot be considered to involve an inventive step when the document is taken alone "Y" document of particular relevance; the claimed invention cannot be considered to involve an inventive step when the document is combined with one or more other such documents, such combination being obvious to a person skilled in the art "&" document member of the same patent family
"A" document defining the general state of the art which is not considered to be of particular relevance "E" earlier application or patent but published on or after the international filing date "L" document which may throw doubts on priority claim(s) or which is cited to establish the publication date of another citation or other special reason (as specified) "O" document referring to an oral disclosure, use, exhibition or other means "P" document published prior to the international filing date but later than the priority date claimed	"T" later document published after the international filing date or priority date and not in conflict with the application but cited to understand the principle or theory underlying the invention "X" document of particular relevance; the claimed invention cannot be considered novel or cannot be considered to involve an inventive step when the document is taken alone "Y" document of particular relevance; the claimed invention cannot be considered to involve an inventive step when the document is combined with one or more other such documents, such combination being obvious to a person skilled in the art "&" document member of the same patent family			
Date of the actual completion of the international search	Date of mailing of the international search report			
11 December 2012	20/12/2012			
Name and mailing address of the ISA/ European Patent Office, P.B. 5818 Patentlaan 2 NL - 2280 HV Rijswijk Tel. (+31-70) 340-2040, Fax: (+31-70) 340-3016	Authorized officer  Ulivieri, Enrico			

# INTERNATIONAL SEARCH REPORT

International application No PCT/US2012/048423
---

C(Continuation). DOCUMENTS CONSIDERED TO BE RELEVANT		
Category*	Citation of document, with indication, where appropriate, of the relevant passages	Relevant to claim No.
X	DE 10 2006 037039 A1 (SIEMENS AG [DE]) 14 February 2008 (2008-02-14) the whole document	1,20,24
X	----- US 2008/141967 A1 (TANI YASUHIDE [JP] ET AL) 19 June 2008 (2008-06-19) the whole document -----	1-4, 8-15,23

# INTERNATIONAL SEARCH REPORT

Information on patent family members

International application No PCT/US2012/048423
---

Patent document cited in search report	Publication date	Patent family member(s)	Publication date
US 5564403	A	15-10-1996	NONE
-----			
WO 8804729	A1	30-06-1988	AU 1088188 A 15-07-1988
			CA 1311795 C 22-12-1992
			EP 0339043 A1 02-11-1989
			JP H02502661 A 23-08-1990
			WO 8804729 A1 30-06-1988
-----			
US 4795937	A	03-01-1989	DE 3544176 C1 21-05-1987
			ES 2003980 A6 01-12-1988
			FR 2591820 A1 19-06-1987
			GB 2184163 A 17-06-1987
			IT 1196840 B 25-11-1988
			JP 62145678 A 29-06-1987
			US 4795937 A 03-01-1989
-----			
WO 2009105273	A1	27-08-2009	CA 2714569 A1 27-08-2009
			EA 201070955 A1 29-04-2011
			EP 2257707 A1 08-12-2010
			JP 2011515005 A 12-05-2011
			KR 20100126757 A 02-12-2010
			US 2009223474 A1 10-09-2009
			WO 2009105273 A1 27-08-2009
-----			
DE 102006037039	A1	14-02-2008	DE 102006037039 A1 14-02-2008
			WO 2008017600 A1 14-02-2008
-----			
US 2008141967	A1	19-06-2008	DE 102007055816 A1 26-06-2008
			FR 2916490 A1 28-11-2008
			JP 2008177142 A 31-07-2008
			US 2008141967 A1 19-06-2008
-----			