

[54] **FLUID OPERATED CONTROL APPARATUS RESPONSIVE TO SENSING A PLURALITY OF MEMBERS CONTAINING ONE OF TWO CODES**

[72] Inventor: **Gerald J. Sukel**, Rochester, N.Y.  
 [73] Assignee: **Eastman Kodak Company**, Rochester, N.Y.  
 [22] Filed: **Nov. 9, 1970**  
 [21] Appl. No.: **88,033**

[52] U.S. Cl. .... **307/144**, 137/81.5, 200/DIG. 5, 200/81.4, 200/81 R  
 [51] Int. Cl. .... **H01h 35/24**, F15c 1/08  
 [58] Field of Search ..... 200/42, 44, 46, 81 R, 81.4, 200/81.5, DIG. 5, 83 R; 137/81.5, 552.5; 307/118, 144; 192/131

[56] **References Cited**

**UNITED STATES PATENTS**

3,534,329	10/1970	Greene .....	200/81.4 X
3,051,872	8/1962	Cowherd .....	307/144 X
3,509,898	5/1970	Monge et al. ....	137/81.5
3,542,049	11/1970	Kobayashi et al. ....	137/81.5
3,427,417	2/1969	Hope .....	200/83 R
2,944,558	7/1960	Dodge .....	200/81 R X

3,317,039 5/1967 Wadey.....137/81.5 X  
 3,270,960 9/1966 Phillips.....235/201

*Primary Examiner*—Robert K. Schaefer  
*Assistant Examiner*—Robert A. Vanderhye  
*Attorney*—Robert W. Hampton and G. Herman Childress

[57] **ABSTRACT**

Fluid operated apparatus for controlling the operation of a device actuator that is connectable in an electric circuit and adapted to be energized in response to sensing of the presence of a particular coding on a film cartridge or other member. Fluid operated means senses the coding on a cartridge and selectively controls the application of fluid pressure to a fluid operated switch so that the switch is opened or closed according to the coding sensed. Electrical contacts of the switch are connectable in a circuit including the device to be controlled so that the device is operated only in response to the presence of a cartridge having a particular code thereon. In a preferred embodiment disclosed the apparatus is adapted to sense two particular cartridge codes and to operate a punch used to strip film from the cartridge only when a conditioning switch on a film processor indicates that the processor is set to handle the film type that is in the cartridge.

**5 Claims, 4 Drawing Figures**

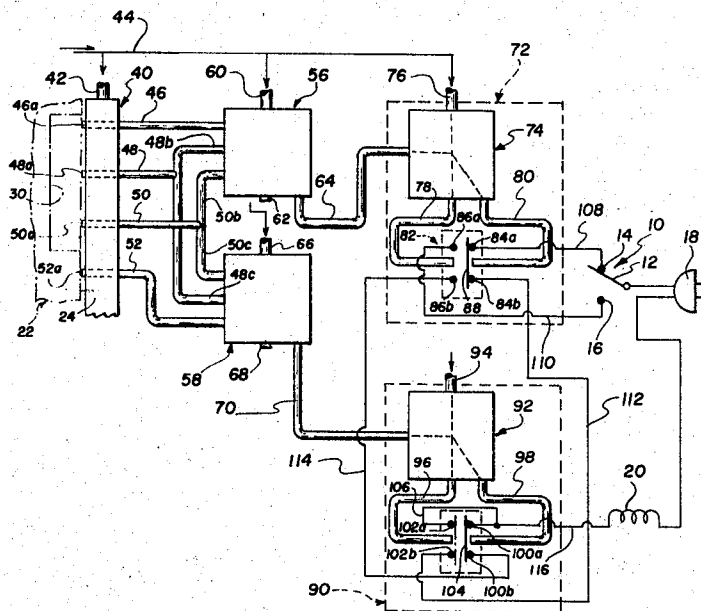

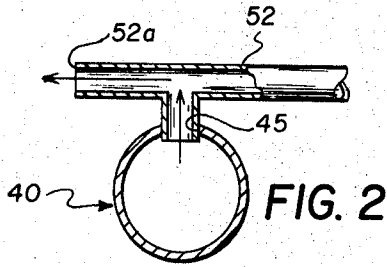

FIG. 2

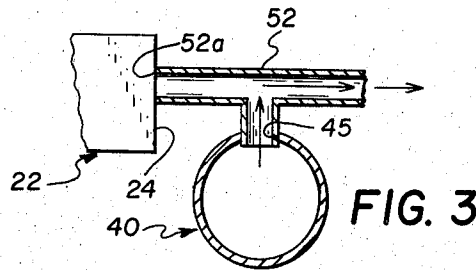

FIG. 3

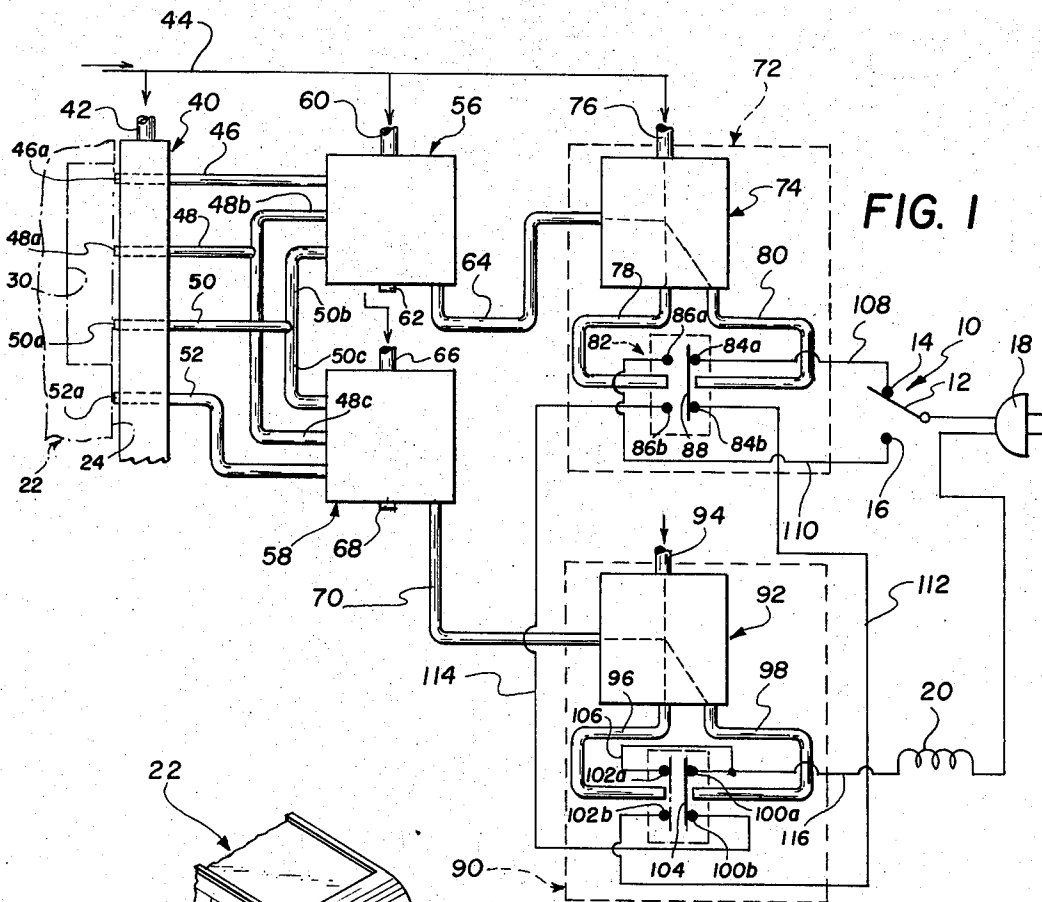

FIG. 1

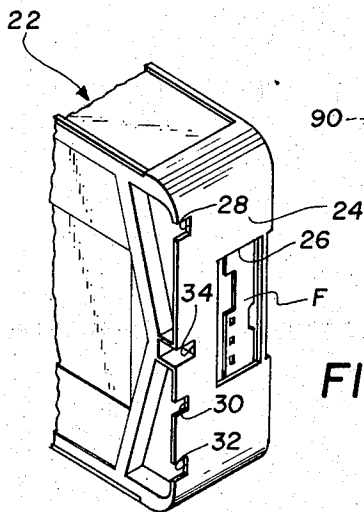

FIG. 4

GERALD J. SUKEL  
INVENTOR.

BY *J. Herman Children*  
*Robert W. Hampton*

ATTORNEYS

## FLUID OPERATED CONTROL APPARATUS RESPONSIVE TO SENSING A PLURALITY OF MEMBERS CONTAINING ONE OF TWO CODES

### CROSS-REFERENCE TO RELATED APPLICATION

Reference is made to commonly assigned co-pending U.S. Pat. application Ser. No. 61,594, entitled FILM PROCESSING APPARATUS FOR PROCESSING FILMS OF DIFFERENT TYPE, filed in the name of E. W. Jensen on Aug. 6, 1970.

### BACKGROUND OF THE INVENTION

The beforementioned copending application discloses a film processor that is adapted to handle two different types of films. A switch in the processor is set to either of two operative positions so that when a cartridge containing film is presented, suitable cartridge sensing means cooperate with that switch to permit operation of a device for extracting film from the cartridge only if the switch is set at a position that conditions the apparatus for handling the type of film sensed by the cartridge sensing means. The present application relates to a particular apparatus for sensing a particular code or codes on cartridges, and for cooperating with the switch disclosed in the copending application for actuating the device, such as a punch or the like.

Various fluid controlled or fluid operated devices are well known for sensing the presence (or absence) of a work piece and for controlling operation of a device in response to such sensing. For example, sorting apparatus used for sorting perforated cards used in data processing machines are frequently fluid operated. However, prior film processing film apparatus have relied primarily on an operator visually determining the film type to be fed to the processor. If there is an operator error and film of the wrong type is furnished to the processor, the film can be ruined during processing. Also, such manual detection of a particular film type is expensive since it is time consuming and requires a full time operator. High volume, economical film processing requires substantially automatic sensing of film types and substantially 100 percent accuracy in detection of the type of film being fed to the apparatus. Mechanical and photoelectric sensing devices are not altogether suitable for sensing film cartridges due to lack of reliability over long periods of operation and/or danger of exposing film to a light beam.

### SUMMARY OF THE INVENTION

Accordingly it is an object of the invention to provide fluidic apparatus for controlling the operation of a device, such as a portion of a film processor, in response to the sensing of the presence of a member having thereon means defining a code identifying the member so that the device is operated only when the proper code is sensed by the apparatus; and to provide such apparatus that is capable of sensing more than one code and for cooperating with a multi-position switch for coordinating operation of the device in response to both the position of the switch and the presence of a member with the correct code thereon. Another object of the invention is to provide apparatus of the type described wherein a particular code on a film cartridge can be sensed without the use of photoelectric or mechanical apparatus. A further object of the inven-

tion is to provide such apparatus which is fluid operated and wherein only slight pressure need be exerted for sensing.

In accordance with the present invention, apparatus is provided for controlling the operation of a device in response to sensing the presence of a member having thereon means defining a code for identifying the member. The apparatus includes fluid operated electrical switch means having a fluid inlet and having means communicating with the inlet for changing the switch means from one state to another state in response to fluid pressure conditions at the inlet. The switch means is adapted to be connected in a circuit for regulating operation of a device so that the device is energized in response to fluid pressure conditions at the inlet. Means are provided for sensing the code defining means on said member and for varying the fluid pressure condition at the fluid inlet in response to such sensing.

### BRIEF DESCRIPTION OF THE DRAWINGS

In the detailed description of the preferred embodiments of the invention presented below, reference is made to the accompanying drawings, in which:

FIG. 1 is a schematic view of fluid operated apparatus of the invention for controlling the operation of a device;

FIG. 2 is an enlarged detail view showing a portion of the apparatus for sensing coding on a camera cartridge or the like;

FIG. 3 is a view similar to FIG. 2 showing a cartridge or other member being sensed by the apparatus; and

FIG. 4 is a fragmentary view of a camera cartridge having coding thereon defined by notches that can be sensed by using the apparatus of the invention.

### DESCRIPTION OF THE PREFERRED EMBODIMENT

Because photographic apparatus are well known, the present description will be directed in particular to elements forming part of, or cooperating more directly with, the present invention, photographic apparatus not specifically shown or described herein being understood to be selectable from those known in the art.

By way of example, the preferred embodiment of the apparatus of the invention is disclosed in connection with film processing apparatus of the general type disclosed in the commonly assigned, copending U.S. Pat. application entitled FILM PROCESSING METHOD AND APPARATUS, Ser. No. 820,379, filed on Apr. 29, 1969 in the name of James L. Hart et al., now abandoned in favor of continuation application No. 126,979. Also, apparatus for processing films of various types is disclosed in the commonly assigned, copending U.S. Pat. application Ser. No. 61,594, entitled FILM PROCESSING APPARATUS FOR PROCESSING FILMS OF DIFFERENT TYPE, filed on Aug. 6, 1970 in the name of Einar W. Jensen. The latter application discloses a film processor apparatus having two chambers for processing liquids, one of which is used for processing a film of one type or ASA number, and the other of which is used for processing film of a different type or ASA number. For example, the processor may handle films having film speed ratings of either ASA 40 or ASA 160 by selectively

passing film through one or the other of the chambers. As the processor is being set up, a conditioning switch, such as shown at 10 in the present application, is set to either one of two closed positions wherein a movable switch member 12 is brought into engagement with a switch contact 14, or alternatively, a switch contact 16. Switch member 12 is connected to a source of electrical potential, such as by an electrical connector 18. Also connected to the source of electrical potential or connector 18 is an electrically energizable device shown schematically at 20. The device 20 may be, for example, an electrically operable punch device such as disclosed in the commonly assigned copending U.S. Pat. application Ser. No. 813,526, filed Apr. 4, 1969 in the names of Robert C. Sutliff and Archie J. Tucker, entitled CARTRIDGE AND METHOD FOR REMOVING FILM FROM THE CARTRIDGE, now U.S. Pat. No. 3,550,877. The punch device described in that application is operable to penetrate the side walls of a film cartridge such as shown in FIG. 4 for disabling an anti-backup mechanism (not shown) within the cartridge, thereby to permit extraction of film from the cartridge through an exposure aperture in the cartridge. The apparatus of the present invention is adapted to sense the coding on a cartridge that is indicative of characteristic of film in a cartridge presented to such film processing apparatus, and to energize the device 20 if (and only if) the type of film in the cartridge (as sensed by the apparatus of the invention) is the type of film the processor is conditioned to handle (as indicated by the position of the conditioning switch 10). Thus the apparatus verifies manual sorting of film cartridges by types of film in the cartridges.

Before proceeding with the description of the apparatus of the invention, reference will be made to FIG. 4 which illustrates a portion of a conventional super 8 film cartridge generally designated 22. The cartridge has an end wall 24 with an aperture 26 therein through which film F in the cartridge can be exposed and through which film can be extracted from the cartridge in the manner described in the beforementioned copending application in the name of Sutliff et al. Wall 24 of the cartridge normally is provided with code markings in the form of notches 28, 30 and 32. Notch 28 conventionally designates the ASA film speed or rating of the film contained within the cartridge. Notch 30 normally is used as a product identification notch, and it is this notch that is sensed by apparatus of this invention. The presence of a notch as shown at 32 indicates that the cartridge is loaded with film that requires exposure by artificial light. In addition, the cartridge can be provided with a centrally located slot 34 that is used for positioning the cartridge accurately in a camera or in film processing apparatus.

Referring now to FIGS. 1-3, the apparatus of the present invention comprises a manifold 40 having a fluid inlet 42 through which air or other gaseous fluid under pressure is adapted to be furnished to the manifold from a supply line diagrammatically shown at 44. The manifold has a plurality of outlet ports or openings 45 that preferably are equally spaced along the length of the manifold. Four such ports or outlets are illustrated in the drawings; however, more or fewer ports can be provided, depending upon the variety of codes to be sensed by the apparatus. Each of the outlet

ports communicates with a conduit or line defining a fluid passage, four of which are illustrated in the drawings and designated 46, 48, 50 and 52. As shown in FIGS. 2 and 3 for conduit 52, one end 52a of each conduit normally is open to permit venting of fluid from the manifold through the various passages. However, if the open end of a conduit is closed (by a solid portion of cartridge 22 adjacent notch 30, for example), then there is a slight increase in the fluid pressure in the other (right) end of the conduit or passage. Thus the fluid pressure conditions in conduits 46-52 can be used to determine the presence of a cartridge having a particular arrangement of code notching indicative of a film type or characteristic. In order to simplify the drawings, the cartridge is shown positioned directly against one end of conduits 46-52. However, in practice, these conduits may be connected to a cartridge holder (not shown) that locates end wall 24 of the cartridge properly for fluid sensing by the apparatus of the invention and for stripping of film from the cartridge.

Each conduit 48 and 50 has at its right end two branch passages 48b, 48c and 50b and 50c. The right end of passages 46, 48b and 50b are connected to a fluidic device 56, and the right end of fluid passages 50c, 48c and 52 are connected to a similar fluidic device 58. The fluidic devices 56 and 58 are preferably conventional fluidic industrial control modules known as OR/NOR gates that are available from various industrial sources, including the Fluidic Products Department, Corning Glass Works, Corning, New York. Device 56 has a fluid inlet connected via conduit 60 to the source 44 of fluid under pressure. The device 56 has two fluid outlets connected to a fluid vent 62 and to a conduit or fluid passage 64. Normally, air or other fluid under pressure entering the device 56 through supply conduit 60 is exhausted through vent 62. However, in response to an increase in fluid pressure in any or all of the inlet conduits 46, 48 and/or 50, fluid furnished to the device through conduit 60 is directed into the passage or fluid conduit 64, thereby increasing the fluid pressure in that conduit. In a similar manner, device 58 normally receives fluid under pressure from source 44 through a fluid supply conduit 66 connected to the fluid inlet of the device. Normally air is vented from the device through a vent or outlet 68. When fluid pressure increases in any or all of conduits 48, 50 and/or 52, fluid under pressure entering the device from line 66 is provided to a conduit or fluid passage 70 thereby increasing the fluid pressure in that passage. In the embodiment disclosed the apparatus is intended to sense cartridge coding that either blocks conduit end 46a and leaves unblocked conduit ends 48a, 50a and 52a or blocks end 52a and leaves ends 46a, 48a and 50a unblocked. For this particular code sensing conduits 46 and 52 may be considered control conduits since device 56 is responsive to changes in fluid pressure in conduit 46 and device 58 is responsive to changes in fluid pressure in conduit 52. Of course, this particular coding is merely representative of various notching combinations that can be sensed by the apparatus so that any or all of conduits 46, 48, 50 and 52 may be control conduits. Thus the provision of conduits 48 or 50 permit sensing of additional film types.

Passage 64 couples the output of the OR/NOR gate 56 to a fluidic-to-electric switch generally designated

72. Switch 72 comprises a fluid device generally shown at 74 which has a fluid inlet connected via a conduit 76 to the source 44 of fluid under pressure. Normally fluid entering the device 74 through passage 76 is vented through a first outlet to a passage or conduit 78. However, when there is an increase in fluid pressure in passage 64 due to an increase in the fluid pressure in the control passage 46, then fluid entering device 74 through conduit 76 is discharged from the device into a passage or conduit 80.

Passages 78 and 80 are connected to a double pole, double throw, diaphragm-operated electric switch generally designated 82 and comprising a first pair of electrical contacts 84a and 84b and a second pair of electrical contacts 86a and 86b. A switch contact member 88, which is normally spring biased against electrical contacts 84a and 84b to complete a circuit therebetween, can be moved to the left (as viewed in FIG. 1) into engagement with contacts 86a and 86b, thereby to establish electrical contact between such contacts and to terminate the electrical contact between the contact members 84a and 84b. This movement of the switch member against its spring bias to change the switch from one state to another is achieved in response to an increase in fluid pressure in passage 80. When fluid under pressure is directed from device 74 into passage 78, the resulting increase in fluid pressure at the left side of the diaphragm or switch member (and the corresponding decrease in pressure in line 80) helps the switch spring move the contact member to the position shown in FIG. 1 and maintain the switch closed to contacts 84a, 84b.

A second fluidic-to-electric switch is generally designated 90 and it is similar in construction and operation to switch 72. Switch 90 comprises a fluidic device 92 that normally receives at its inlet fluid under pressure through conduit or passage 94 and the fluid pressure source 44. Normally, this fluid is discharged to a conduit or passage 96. Device 92 also is connected to passage 70 so that an increase in fluid pressure in passage 70 deflects fluid entering the device through passage 94 and provides such fluid into a control conduit or passage 98. Switch 90 further includes a first pair of electrical contacts 100a, 100b and a second pair of electrical contacts 102a, 102b. A switch member 104 is movable between the position shown in solid lines in FIG. 1 wherein it closes a circuit between contacts 100a, 100b and a second position shown in dashed lines in FIG. 1 wherein it closes a circuit between contacts 102a, 102b. This movement of the member 104 is in response to fluid pressure conditions in passages 96 and 98 in the same manner described hereinbefore in connection with switch 72. Switch 90 is identical in construction to the switch 72 except that the contacts 100a and 102a are electrically interconnected by a conductor 106.

Contact 84a of switch 72 is connected by a conductor 108 to terminal or contact 14 of switch 10, and the other terminal or contact 16 of switch 10 is connected by conductor 110 to contact 86a. Contact 84b of switch 72 is connected by a conductor 112 to contact 102b of switch 90, and switch contacts 86b and 100b are interconnected by a conductor 114. Switch contacts 100a and 102a are connected to the device 20 by conductor 116.

Operation of the apparatus of the invention will now be described. First of all, when none of the passage ends 46a, 48a, 50a or 52a are blocked, as will occur if no cartridge is presented to the apparatus or if the cartridge presented has a sufficiently wide notch 30 to leave unblocked all of the passage ends, then fluid under pressure furnished to devices 56 and 58 from supply line 44 will be vented through their outlets 62 and 68, respectively. Therefore, no fluid under pressure is provided to passages 64 and 70, and fluid-operated switches 72 and 90 remain in the states shown in solid lines in FIG. 1. As a result, the electrical circuit to device 20 is open whether conditioning switch 10 is closed to contact member 14 or to contact member 16.

Next it will be assumed that the contact member 12 is closed to switch contact 14 and that this conditions the film processing apparatus to receive film from a film cartridge 22 having coding that blocks the end 52a of passage 52 but leaves unblocked the ends 46a, 48a and 50a as shown in FIG. 1. The presence of such coding causes the fluid device 58 to provide fluid under pressure from conduit 66 of the device 58 to device 92 through the outlet conduit 70. This, in turn, provides fluid under pressure from device 92 to conduit 98 of the fluid to electric switch 90, thereby causing contact member 104 to move from engagement with contacts 100a, 100b to engagement with the contacts 102a and 102b as shown in dashed lines in FIG. 1. This completes an electrical circuit to the device 20 for actuating the device. The electrical circuit can be traced as follows: from the power source 18 through switch member 12 and contact 14 to conductor 108, through switch contact member 88 and conductor 112 to switch contact 102b, across switch member 104 to contact 102a, and then through conductor 106 and 116 to the device 20. Processing of film can proceed in the usual and normal manner. In a similar manner the actuator 20 will be energized if the switch contact member 12 is moved into engagement with the contact 16 and if a cartridge 22 presented to the apparatus has a notch 30 that closes the end 46a of passage 46 and leaves passage ends 48a, 50a and 52a unblocked.

Actuator 20 will not be energized unless the particular coding on a cartridge presented to the apparatus indicates the film in the cartridge is of the type that the processor can handle as determined by the position of switch 10. For example, if all of the passage ends 46a, 48a, 50a and 52a are blocked by a cartridge having no notches, then both of the fluid-to-electric switches 72 and 80 are switched. As a result the electrical circuit to actuator 20 remains open. Thus it will be seen that the apparatus of the present invention verifies presorting of cartridges and permits operation of the actuator only when the cartridge presented is notched to indicate a film type or characteristic that corresponds to the setting of the conditioning switch 10 of the film processor. The apparatus of the invention is particularly desirable for sensing a code where photoelectric or mechanical systems are not desirable. Very little pressure is required to operate the fluidic devices 56 and 58, typically less than 1/100th of one pound per square inch being sufficient for operation of these devices. While the apparatus of the invention has been described in connection with the sensing of a particular code on film cartridges, and in connection with the

operation of film processing apparatus it will be apparent to those skilled in the art that codes on articles other than cartridges can be sensed, and that the apparatus can be used in connection with devices other than an actuator for a film processor.

The invention has been described in detail with particular reference to preferred embodiments thereof, but it will be understood that variations and modifications can be effected within the spirit and scope of the invention.

I claim:

1. Apparatus for controlling the operation of an electrically energizable device in response to sensing the presence of film cartridges containing either one of two types of film to be processed by a film processor, the cartridges each having on one surface thereof means defining one of two identifiable codes indicative of a characteristic of film within the cartridge, the device being connectable in a circuit including a processor conditioning switch that can be set to either of two closed positions for conditioning the processor to handle film having two different characteristics, the apparatus comprising:

two fluid operated electrical switches, each of said switches having (1) two pairs of electrical contacts, (2) a fluid inlet for receiving fluid under pressure, (3) a movable member for completing a circuit between one or the other of said pairs of contacts in response to fluid pressure conditions at said inlet, and (4) means operably associated with said member for moving said member to selectively open and close the circuit between said pairs of contacts in response to fluid pressure conditions at said fluid inlet, said contacts being adapted to be connected in a circuit including said device and said conditioning switch;

two fluid operated OR/NOR gates, each of said gates having (1) a fluid inlet adapted to be connected to a source of fluid under pressure, (2) a first fluid outlet through which fluid from the inlet normally is discharged, (3) a second fluid outlet, and (4) a second inlet adapted to receive fluid under pressure and to effect discharge of fluid from the gate through the second outlet, the second fluid outlet of a first one of said gates being connected to the inlet of one of said switches and the second fluid outlet of a second one of said gates being connected to the fluid inlet of the other of said switches;

means connected to the second inlet of each of said gates for providing fluid under pressure thereto to actuate the gate to provide fluid from the first inlet to the second outlet thereof in response to sensing of particular codes on cartridges; and

means completing electrical circuits between said pairs of contacts of said switches, said conditioning switch and said device so that a particular cartridge coding can be sensed by said gates for operating one or the other of the fluid operated switches to complete a circuit to the device and the conditioning switch if the conditioning switch is set to a position indicating the processor is set to process film of the type contained in the cartridge as indicated by the coding on the cartridge.

2. Apparatus for controlling the operation of an electrically energizable device in response to sensing on a plurality of members to be furnished to the apparatus one of two distinctly different codes used for identifying the members, the apparatus comprising:

an electrical circuit comprising first and second fluidic-to-electric switches adapted to be connected for regulating operation of the device, each of said fluidic-to-electric switches having (1) means for receiving a fluid under pressure and (2) electrical switch means changeable from a first state to a second state in response to pressure conditions of a fluid furnished to the fluid receiving means, said switches being electrically connected in the circuit so that the device can be energized if one of the switch means is in its second state;

means for controlling the states of said switch means comprising (1) means for sensing each of the two codes and (2) means coupling said sensing means to the fluid receiving means of said fluidic-to-electric switches for (a) effecting a change in the condition of the fluid furnished to said first fluidic-to-electric switch to change its switch means to its second state in response to sensing the presence of one of the codes and (b) effecting a change in the condition of the fluid furnished to said second fluidic-to-electric switch to change its switch means to its second state in response to sensing the presence of one of the codes; and

a conditioning switch having two closed positions for conditioning the device to handle members having one or the other of the different codes identifying the members, said conditioning switch being connected in the circuit so that (1) when it is set to one of its closed positions it permits energization of said device when the presence of a member having one of said codes is sensed by said sensing means and (2) when it is set to the other of its closed positions it permits energization of said device when the presence of a member having the other of said codes is sensed by said sensing means.

3. Apparatus as set forth in claim 2 wherein the means for controlling the state of said switch means comprises a fluid-operated device having (1) an inlet for receiving fluid, (2) a first fluid outlet through which fluid normally is vented from the device, and (3) a second fluid outlet through which fluid can be discharged from the device in response to fluid pressure conditions at the inlet, the second fluid outlet being connected to said switch means.

4. Apparatus as set forth in claim 2 wherein said means for controlling the states of said switch means comprises two fluidic OR/NOR gates, each of said gates having (1) a fluid outlet connected to said receiving means of one of said switch means and (2) a fluid inlet connected to said sensing means for receiving fluid from said sensing means, said gates being operable to provide fluid under pressure to said switches in response to the sensing of a member containing one of said codes.

5. Apparatus as set forth in claim 2 wherein said switch means of said switches are electrically connected in said circuit so that the circuit is ineffective to operate the device when both of said switch means are in their first state or in their second state.

\* \* \* \* \*