



(12) EUROPEAN PATENT APPLICATION

(43) Date of publication:
24.11.1999 Bulletin 1999/47

(51) Int. Cl.⁶: E04G 23/08

(21) Application number: 98109026.9

(22) Date of filing: 18.05.1998

(84) Designated Contracting States:
AT BE CH CY DE DK ES FI FR GB GR IE IT LI LU
MC NL PT SE
Designated Extension States:
AL LT LV MK RO SI

• Okada, Hiroshi
1300-80, Yabata, Nabari, Mie (JP)
• Itoh, Yoshifumi
1300-80, Yabata, Nabari, Mie (JP)

(71) Applicant:
NIPPON PNEUMATIC MANUFACTURING CO.
LTD.
Osaka (JP)

(74) Representative:
Schieschke, Klaus, Dipl.-Ing.
Patentanwälte
Eder & Schieschke,
Elisabethstrasse 34/II
80796 München (DE)

(72) Inventors:
• Okumura, Takashi
1300-80, Yabata, Nabari, Mie (JP)

(54) Crusher

(57) A crusher which is simple in structure and capable of dismantling a building structure and recovering iron material from among dismantled remains of a building. A movable jaw (17) is provided so as to be opened and closed relative to a fixed jaw (16) fixed to the crusher main frame (10). A magnetic case (24) made of a nonmagnetizable material is provided on the bottom of the main frame. A permanent magnet assembly (29) is slidably mounted in the case (24). The permanent magnet assembly (29) is connected to a hydraulic cylinder (33) for sliding the permanent magnet (29). By actuating the cylinder (33), the permanent magnet (29) will move down so that iron material is attracted through a bottom plate (25) of the magnet case (24). By raising the permanent magnet assembly (29), the magnet weakens, so that the attracted iron material drops by gravity.

FIG. 1

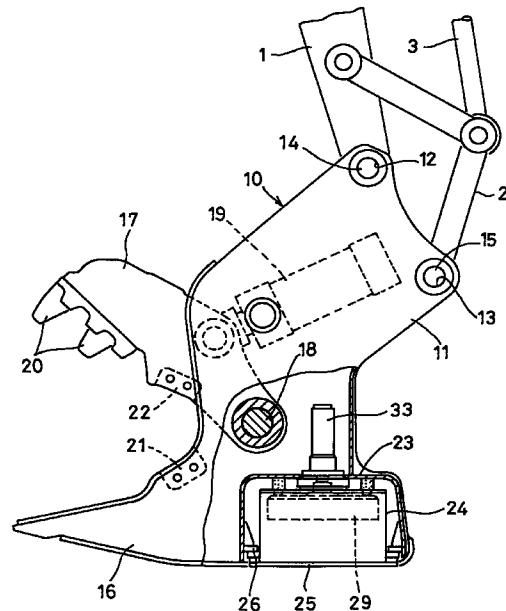

Description

BACKGROUND OF THE INVENTION

[0001] This invention relates to a crusher used to dismantle buildings and other structures.

[0002] A crusher is mounted on an arm tip of a civil engineering machine such as a backhoe to dismantle buildings.

[0003] The crusher has a fixed jaw secured to the crusher main frame, and a movable jaw provided pivotally opposite the fixed jaw. The movable jaw is opened and closed by a hydraulic cylinder to dismantle a building and break dismantled material into smaller pieces in cooperation with the fixed jaw.

[0004] Cutting blades provided on the fixed and movable jaws cut iron material, such as iron bars, exposed from the building being dismantled.

[0005] Iron material thus cut is recovered from the dismantled wastes. Manually recovering such iron material is extremely troublesome and also dangerous because the dismantled remains of a building may collapse.

[0006] In order to solve this problem, crushers disclosed in unexamined Japanese patent publications 8-13815 and 4-155068 have a permanent magnet mounted in the main body having the fixed jaw to recover iron material from among dismantled remains by magnetically attracting such iron material with the permanent magnet.

[0007] In the case of the crusher disclosed in unexamined Japanese patent publication 8-13815, a permanent magnet is slid in a composite frame comprising a non-magnetic frame and a magnetic frame. With the permanent magnet in the nonmagnetic frame, iron material is attracted, and the attraction force is released by sliding the permanent magnet into the magnetic frame. To slide the permanent magnet, a force greater than the attraction force applied to the magnetic frame has to be applied to the permanent magnet. Thus, a large load is applied to a link mechanism for converting the opening/closing movement of the movable jaw into sliding motion of the permanent magnet. The link mechanism thus tends to become shaky soon and its life is short.

[0008] In this arrangement, the composite frame is provided in a relatively small space in the crusher body. Only the bottom of the nonmagnetic frame of the composite frame is used as the surface for attracting iron material. Thus, the attracting surface area is thus small, so that it is impossible to recover iron material with high efficiency.

[0009] In the case of the crusher disclosed in unexamined Japanese patent publication 4-155068, a permanent magnet is slidably mounted in a nonmagnetic casing to define front and rear chambers in the casing. Pressure oil is alternately supplied into one of the chambers to move the permanent magnet. Thus, the permanent magnet, which corresponds to a piston of a hydraulic cylinder, tends to be influenced by water con-

tained in pressure oil.

[0010] Further, it is necessary to seal the front and rear chambers from each other by mounting a seal member on the outer periphery of the permanent magnet. Since the permanent magnet with the seal member is slid along the inner surface of the casing, the inner surface of the casing has to be finished with extremely high accuracy. Thus, machining is extremely troublesome and costly.

[0011] An object of this invention is to provide a crusher with a permanent magnet which is simple in structure and inexpensive.

SUMMARY OF THE INVENTION

[0012] According to this invention, there is provided a crusher comprising a frame having a pair of side plates, a fixed jaw fixed to the frame, a movable jaw pivotally supported on the frame at a position opposite the fixed jaw, a first hydraulic cylinder for opening and closing the movable jaw relative to the fixed jaw, a magnet case mounted between the pair of side plates of the frame, a permanent magnet assembly slidably mounted in the magnet case, and a second hydraulic cylinder connected to the permanent magnet assembly for sliding the permanent magnet assembly, the first and second hydraulic cylinders being operatively associated with each other.

[0013] According to the present invention, on-off valves are provided in an oil feed line communicating with the front chamber of the second hydraulic cylinder and in an oil feed line communicating with the rear chamber of the second hydraulic cylinder. By actuating the on-off valves, pressurized oil can be sealed in the front or rear chamber of the hydraulic cylinder. Thus the permanent magnet can be moved only when collecting the iron bars and can be held in an inoperative position when breaking the dismantled material and cutting the iron bars.

[0014] Also, according to the present invention, a throttle is provided between one of the on-off valves and the front chamber of the second hydraulic cylinder, and a check valve is provided in a bypass line having one end thereof communicating with the inlet end of the throttle and the other end with the outlet end of the throttle. This prevents oil in the front chamber of the second hydraulic cylinder from flowing through the bypass line. This assures that the permanent magnet moves quickly away from the bottom plate of the magnet case and moves slowly toward the bottom plate.

[0015] Other features and objects of the present invention will become apparent from the following description made with reference to the accompanying drawings, in which:

BRIEF DESCRIPTION OF THE DRAWINGS

[0016]

Fig. 1 is a partially cutaway front view of a crusher embodying this invention;

Fig. 2A is an enlarged sectional view of an iron attracting portion of the crusher of Fig. 1;

Fig. 2B is a section taken along line II-II of Fig. 2A; and

Fig. 3 shows a hydraulic circuit of the crusher of Fig. 1.

DETAILED DESCRIPTION OF THE PREFERRED EMBODIMENT

[0017] Now an embodiment of this invention is described with reference to the attached drawings.

[0018] As shown in Fig. 1, a main frame 10 has a pair of side plates 11 each formed with a pair of pin holes 12, 13 at the upper portion thereof.

[0019] The frame 10 is pivotally mounted on the tip of an arm 1 of a civil engineering machine by a pin 14 inserted through the holes 12. A two-joint link 2 has one end thereof coupled to the tip of the arm 1 and the other end to the frame 10 by a pin 15 inserted through the holes 13.

[0020] A cylinder 3 is coupled to the connecting portion of the joints of the link 2. By activating the cylinder 3, the frame 10 is pivoted about the pin 14.

[0021] A fixed jaw 16 is provided at one side of the lower portion of the frame 10. Opposite the jaw 16, a movable jaw 17 is pivotally supported on a shaft 18 extending between the pair of side plates 11.

[0022] The movable jaw 17 is opened and closed relative to the fixed jaw 16 by a hydraulic cylinder 19 provided between the pair of side plates 11.

[0023] The movable jaw 17 has crushing teeth 20 at its tip. The fixed jaw 16 and the movable jaw 17 carry cutting blades 21, 22, respectively, opposite each other to cut iron members.

[0024] An open-bottomed housing 23 is provided at the bottom of the frame 10. A hollow magnet case 24 is mounted in the housing 23.

[0025] The magnet case 24 is made from a nonmagnetizable material, and as shown in Fig. 2A, has a bottom plate 25 fixed by tightening bolts 27 against supports 26 fixed to the inner surface of the housing 23 near its bottom.

[0026] In the case 24, a permanent magnet assembly 29 is vertically slidably supported between vertical guides 28. The permanent magnet assembly 29 comprises an open-bottomed, box-shaped yoke 30 made from a magnetizable material, and a permanent magnet 31 mounted in the yoke 30. The yoke 30 has at its top a coupling piece 32 coupled to a piston rod 34 of a hydraulic cylinder 33 for sliding the magnet 31. The cylinder 33 is bolted to a top plate 35 of the magnet case

24. Cushioning members 36 are provided on the top plate 35 to absorb shocks when the permanent magnet assembly 29 collides against the top plate 35.

[0027] Fig. 3 shows a hydraulic circuit. Oil feed lines 37a and 37b are connected to a cylinder front chamber 19a and a cylinder rear chamber 19b of the hydraulic cylinder 19 to open and close the movable jaw 17, respectively.

[0028] From a hydraulic pressure generating unit (not shown) mounted on the civil engineering machine, pressure oil is supplied to the oil feed lines 37a, 37b through a changeover valve. Lines 38a and 38b branch from the lines 37a and 37b, respectively. The line 38a is connected to a front chamber 33a of the cylinder 33, while the other line 38b is connected to its rear chamber 33b.

[0029] Thus, when pressure oil is supplied into the line 37a to open the movable jaw 17, pressure oil in the line partially flows into the front chamber 33a of the cylinder 33, thus raising the permanent magnet assembly 29. When the movable jaw 17 is closed, the permanent magnet assembly 29 is lowered.

[0030] On-off valves 39a and 39b are provided in the lines 38a and 38b, respectively, to selectively supply pressure oil to the hydraulic cylinder 33. The line 38a communicating with the front chamber 33a has a throttle 40 disposed between the on-off valve 39a and the front chamber 33a. The hydraulic circuit further includes a bypass line 41 having one and the other ends thereof communicating with the inlet and outlet ends of the throttle 40, respectively. A check valve 42 is provided in the bypass line 41 to prevent oil in the front chamber 33a from flowing through the bypass line 41 toward the on-off valve 39a.

[0031] In operation, the movable jaw 17 is opened and closed about the shaft 18 by supplying pressure oil to the hydraulic cylinder 19 to dismantle a building with the movable jaw 17 and the fixed jaw 16, and to break dismantled material into smaller pieces and to cut e.g. iron bars.

[0032] If, during dismantling operations, the on-off valves 39a, 39b are open, pressure oil is supplied into the hydraulic cylinder 33. The permanent magnet assembly 29 will thus be unnecessarily moved up and down as the movable jaw 17 is opened and closed. In order to prevent this problem, the on-off valves 39a, 39b are closed to keep the permanent magnet assembly 29 at the elevated position under the pressure of oil sealed in the front chamber 33a.

[0033] To recover iron material such as iron bars from among dismantled wastes, the on-off valves 39a, 39b shown in Fig. 3 are opened to lower the permanent magnet assembly 29 by supplying pressure oil to the rear chamber 33b of the hydraulic cylinder 33. Iron material is thus attracted to the bottom surface of the bottom plate 25 of the magnet case 24 by a magnetic flux flowing through the bottom plate 25.

[0034] When the permanent magnet assembly 29 is lowered, the throttle 40 restricts the flow of oil from the

front cylinder chamber 33a through the line 38a. The assembly 29 is thus lowered slowly, making it possible for the assembly 29 to soft-land on the bottom plate 25.

[0035] Iron material attracted to the bottom 25 of the magnet case 24 is moved to a predetermined position e.g. by turning the arm, and pressure oil is supplied to the front chamber 33a of the hydraulic cylinder 33 to raise the permanent magnet assembly 29. This weakens the magnetic force, so that the iron material drops by gravity.

[0036] As the permanent magnet assembly 29 is raised, pressure oil flowing through the branch line 38a flows into the front cylinder chamber 33a from both the throttle 40 and the check valve 42. This permits the permanent magnet assembly 29 to quickly rise, so that iron material attracted thereto is instantly released and dropped.

[0037] In the embodiment, the hydraulic cylinder 19 for opening and closing the movable jaw 17 is operatively associated with the hydraulic cylinder 33 so that when the movable jaw 17 is opened, the permanent magnet assembly 29 is raised simultaneously. But instead, the oil line may be arranged such that the on-off valve 39a communicates with the rear cylinder chamber 33b and the on-off valve 39b communicates with the front cylinder chamber 33a to raise the permanent magnet assembly 29 when the movable jaw 17 is closed.

[0038] As described above, the lines 38a, 38b branching from the lines 37a, 37b leading to the cylinder for opening and closing the movable jaw are connected to the hydraulic cylinder 33, so that the opening and closing of the movable jaw 17 can be operatively associated with the sliding movement of the permanent magnet assembly 29. The structure is thus simple, and the hydraulic circuit can be constructed easily. The change-over between ordinary operations of dismantling and breakage of material into smaller pieces and iron recovery operations is done easily by opening and closing the on-off valves 39a, 39b provided in the lines 38a, 38b.

[0039] The mounting position of the magnet case 24 is not limited to the bottom of the frame 10. It may be mounted on the other side, i.e. the side on which the fixed jaw 16 is not formed.

[0040] As described above, according to this invention, the structure is simple. No accurate machining of the magnet case and the permanent magnet assembly is required. The entire crusher can thus be manufactured at a low cost. Since the permanent magnet assembly is slid toward and away from the iron attracting surface, it is possible to provide a larger iron attracting surface compared with an arrangement in which the permanent magnet is slid parallel to the iron attracting surface.

[0041] By closing the on-off valves, the permanent magnet assembly is stopped and held at a slide position, so that during crushing of a building, in which the crushing jaws are opened and closed, it is possible to prevent unnecessary movement of the permanent mag-

net.

[0042] The permanent magnet assembly can be moved quickly away from the bottom plate of the magnet case, so that the attraction of iron material can be released instantly. Also, the permanent magnet assembly can be slowly moved toward the bottom plate, so that it is possible to prevent breakage of the bottom plate by colliding with the permanent magnet assembly.

10 Claims

1. A crusher comprising a frame having a pair of side plates, a fixed jaw fixed to said frame, a movable jaw pivotally supported on said frame at a position opposite said fixed jaw, a first hydraulic cylinder for opening and closing said movable jaw relative to said fixed jaw, a magnet case mounted between said pair of side plates of said frame, a permanent magnet assembly slidably mounted in said magnet case, and a second hydraulic cylinder connected to said permanent magnet assembly for sliding said permanent magnet assembly, said first and second hydraulic cylinders being operatively associated with each other.
2. A crusher as claimed in claim 1 further comprising a first on-off valve provided in an oil feed line communicating with a front chamber of said second hydraulic cylinder and a second on-off valve provided in an oil feed line communicating with a rear chamber of said second hydraulic cylinder.
3. A crusher as claimed in claim 2 further comprising a throttle means provided between said second on-off valve and said front chamber of said second hydraulic cylinder, a bypass line having one end thereof communicating with the inlet end of said throttle means and the other end with the outlet end of said throttle means, and a check valve provided in said bypass line for preventing oil in said front chamber of said second hydraulic cylinder from flowing through said bypass line.

FIG. 1

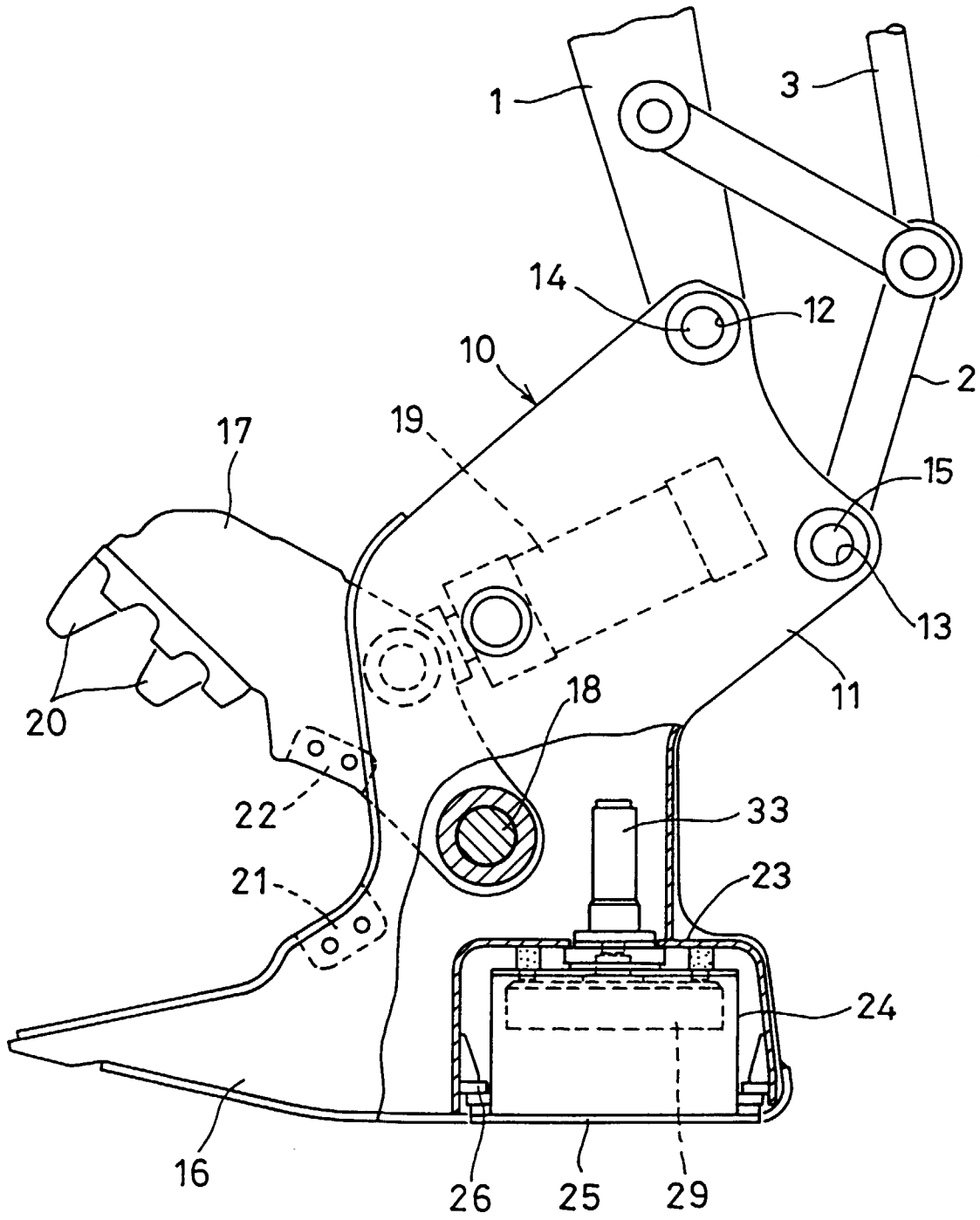

FIG. 2A

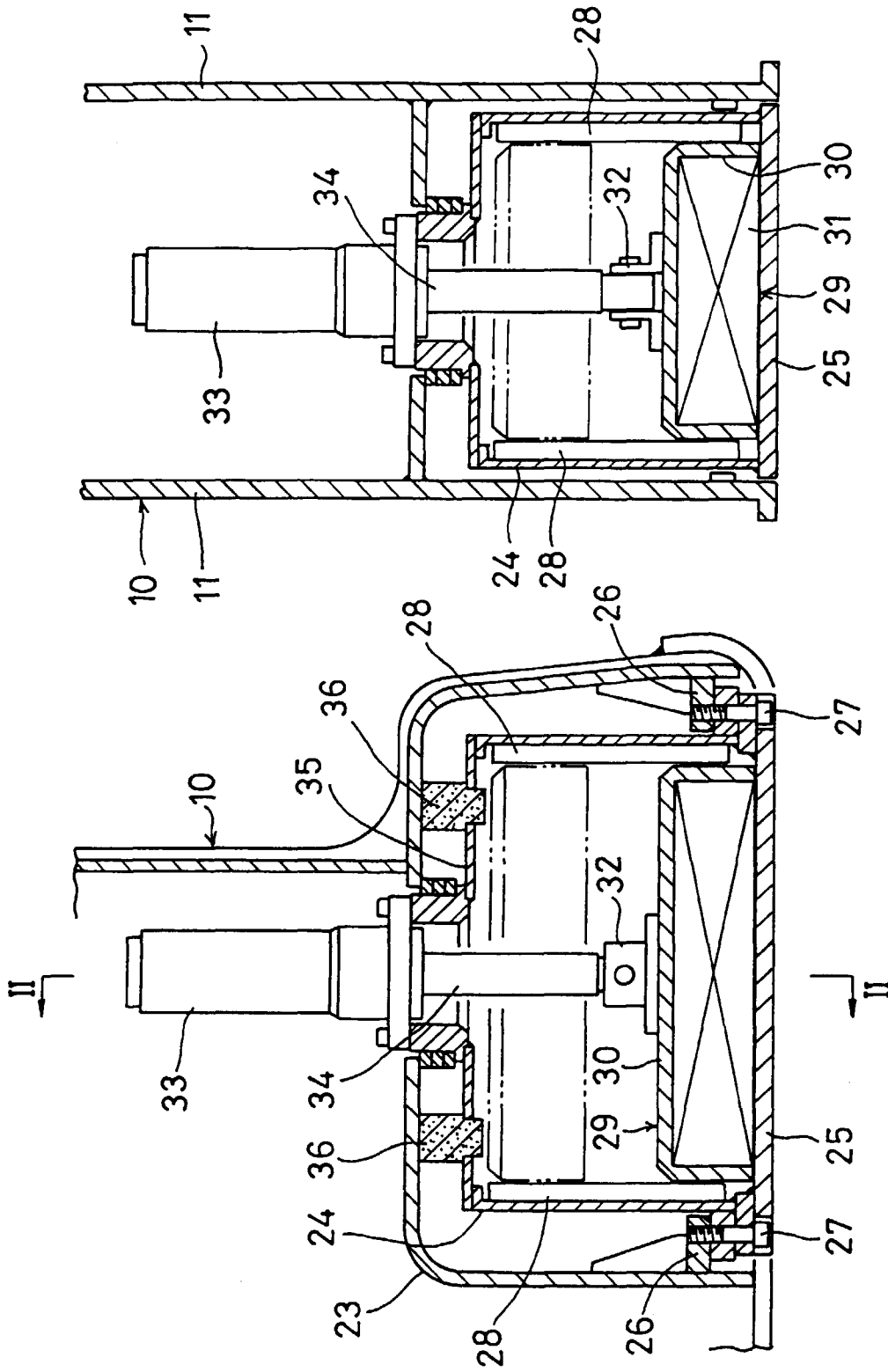
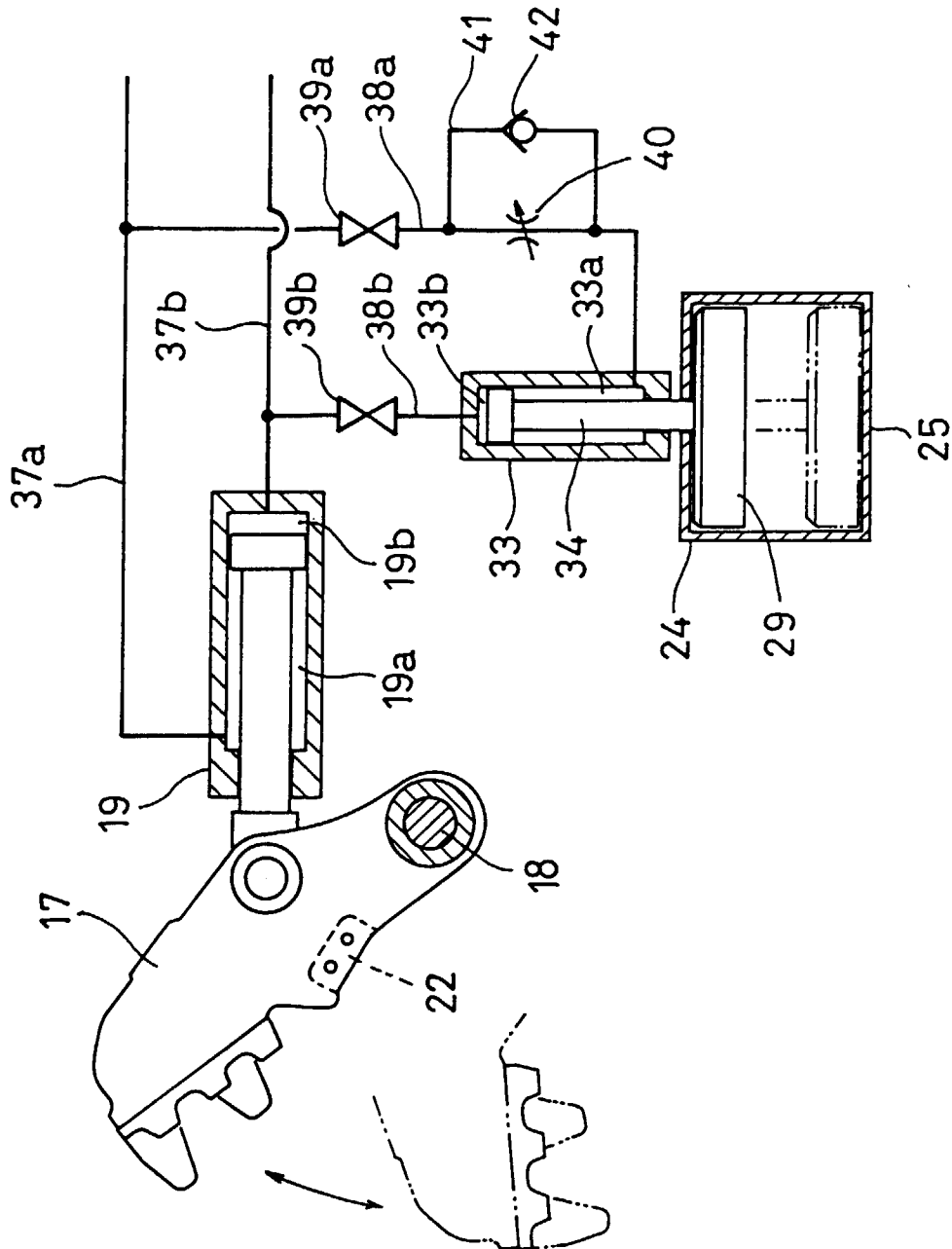

FIG. 2B

FIG. 3





European Patent
Office

EUROPEAN SEARCH REPORT

Application Number
EP 98 10 9026

| DOCUMENTS CONSIDERED TO BE RELEVANT | | | |
|---|---|--|---|
| Category | Citation of document with indication, where appropriate, of relevant passages | Relevant to claim | CLASSIFICATION OF THE APPLICATION (Int.Cl.6) |
| X | DE 195 24 226 A (MAYURAMA CORP.) 18 January 1996 * column 8, last paragraph - column 13; figures * | 1 | E04G23/08 |
| A | DE 197 10 949 A (TAMROCK OY) 30 October 1997 | | |
| The present search report has been drawn up for all claims | | | TECHNICAL FIELDS SEARCHED (Int.Cl.6) E04G B23D |
| Place of search THE HAGUE | | Date of completion of the search 25 September 1998 | Examiner Vijverman, W |
| CATEGORY OF CITED DOCUMENTS X : particularly relevant if taken alone Y : particularly relevant if combined with another document of the same category A : technological background O : non-written disclosure P : intermediate document | | T : theory or principle underlying the invention E : earlier patent document, but published on, or after the filing date D : document cited in the application L : document cited for other reasons & : member of the same patent family, corresponding document | |

EPO FORM 1503 03/82 (P/4C01)

**ANNEX TO THE EUROPEAN SEARCH REPORT
ON EUROPEAN PATENT APPLICATION NO.**

EP 98 10 9026

This annex lists the patent family members relating to the patent documents cited in the above-mentioned European search report. The members are as contained in the European Patent Office EDP file on
The European Patent Office is in no way liable for these particulars which are merely given for the purpose of information.

25-09-1998

| Patent document cited in search report | Publication date | Patent family member(s) | Publication date |
|--|------------------|-------------------------|------------------|
| DE 19524226 A | 18-01-1996 | JP 2650854 B | 10-09-1997 |
| | | JP 8013815 A | 16-01-1996 |
| | | GB 2291397 A,B | 24-01-1996 |
| | | IT 1275453 B | 07-08-1997 |
| | | US 5628611 A | 13-05-1997 |
| DE 19710949 A | 30-10-1997 | FI 99266 B | 31-10-1997 |
| | | JP 10009212 A | 13-01-1998 |
| | | NL 1005506 C | 30-09-1997 |
| | | NL 1005506 A | 17-09-1997 |
| | | US 5784943 A | 28-07-1998 |