

(19) **DANMARK**



Patent- og  
Varemærkestyrelsen

(10) **DK/EP 2207366 T3**

(12) **Oversættelse af  
europæisk patentskrift**

- 
- (51) Int.Cl.: **H 04 R 25/00 (2006.01)** **A 61 B 5/12 (2006.01)**
- (45) Oversættelsen bekendtgjort den: **2014-12-01**
- (80) Dato for Den Europæiske Patentmyndigheds bekendtgørelse om meddelelse af patentet: **2014-09-03**
- (86) Europæisk ansøgning nr.: **10250039.4**
- (86) Europæisk indleveringsdag: **2010-01-11**
- (87) Den europæiske ansøgnings publiceringsdag: **2010-07-14**
- (30) Prioritet: **2009-01-12 US 143820 P**
- (84) Designerede stater: **AT BE BG CH CY CZ DE DK EE ES FI FR GB GR HR HU IE IS IT LI LT LU LV MC MK MT NL NO PL PT RO SE SI SK SM TR**
- (73) Patenthaver: **Starkey Laboratories, Inc., 6600 Washington Avenue South, Eden Prairie, MN 55344, USA**
- (72) Opfinder: **Lopresti, Janice, 21220 Woodview Drive, Itasca, Illinois 60143, USA**  
**Tao, Zhang, 8602 Zachman Circle, Eden Prairie, Minnesota 55344, USA**
- (74) Fuldmægtig i Danmark: **Marks & Clerk (Luxembourg) LLP, 44 rue de la Vallée, B.P. 1775, L-1017 Luxembourg, Luxembourg**
- (54) Benævnelse: **SYSTEM TIL BESTEMMELSE AF NIVEAUET FOR LYDTRYK VED TROMMEHINDEN VED ANVENDELSE AF MÅLINGER VÆK FRA TROMMEHINDEN**
- (56) Fremdragne publikationer:  
**WO-A1-2010/016925**  
**US-A- 4 809 708**  
**US-A1- 2008 194 984**  
**HUDE H ET AL: "Methods for estimating the sound pressure at the eardrum", THE JOURNAL OF THE ACOUSTICAL SOCIETY OF AMERICA, AMERICAN INSTITUTE OF PHYSICS FOR THE ACOUSTICAL SOCIETY OF AMERICA, NEW YORK, NY, US, vol. 106, no. 4, 1 October 1999 (1999-10-01), pages 1977-1992, XP012001248, ISSN: 0001-4966, DOI: 10.1121/1.427945**



FIELD OF TECHNOLOGY

This application relates generally to hearing assistance devices and more particularly to a system for estimating sound pressure level at a wearer's eardrum from sound at another ear canal location.

BACKGROUND

5           Hearing assistance devices, including hearing aids, are electronic devices that provide signal processing functions such as wide dynamic range compression and output compression limiting control. In many hearing assistance devices these and other functions can be programmed to fit the requirements of individual users. Performance of a user's hearing assistance device, while the device is in the user's ear, is difficult to verify. Furthermore, methods that apply at low frequencies may well not work at high  
10 frequencies. The expense of measurement equipment, the time it takes to make the measurements, and the perceived complexity of the procedure, have all proven to be obstacles to widespread use of such measurements. However, such measurements may enable better programming of a user's hearing assistance device because each user's ear is different.

          US 2008/194984 discloses a method for measuring an estimated sound pressure level at a tympanic  
15 membrane in an ear canal of an ear of a wearer of a hearing assistance device using measurements away from the tympanic membrane, the method comprising: placing a sound sampling apparatus in the ear canal at a first position; placing a sound emitter in the ear canal at a second position; generating sound with the sound emitter and receiving sound with the sound sampling apparatus to measure an amplitude response of the ear canal; and determining the estimated sound pressure level at the tympanic membrane using  
20 measurements of sound from the sound sampling apparatus and the measured amplitude response.

The invention is the method and apparatus of Claims 1 and 10.

SUMMARY

          This document provides method and apparatus for estimating the sound pressure level at a user's tympanic membrane, or eardrum. One example provides a hearing assistance device with a sound sampling  
25 apparatus that provides measurements at a first position in the ear canal to generate the sound pressure level at the eardrum of the wearer. This system does not require precise knowledge of the ear canal. Furthermore, it does not require cumbersome calibration steps for each patient, which is critical for practical and efficient real-ear measurement in the clinical environment. In one embodiment, the present approach is implemented in the fitting software and the hearing device. In alternate embodiments, the present system is implemented  
30 completely in the hearing device. In various embodiments, the present approach works at low and high frequencies.

          In various embodiments, the present subject matter provides a method for estimating the sound pressure level at a tympanic membrane in an ear canal of an ear of a wearer of a hearing assistance device using measurements away from the tympanic membrane according to claim 1.

35           Variations of the foregoing methods include wherein placing a sound sampling apparatus comprises placing a thin tube with an end at the first position for sampling sound at the first position. Variations further include placing a second end of the thin tube in a microphone port of the hearing assistance device. Variations include wherein placing a sound sampling apparatus comprises placing a microphone at the first position. In some variations the sound sampling apparatus is a microphone fitted

- 2 -

with a small sound tube and wherein the sound emitter is a receiver. In some embodiments the first position and the second position have a minimum distance of about 5 mm. Different ways of emitting sound include, but are not limited to playing a swept audio sound into the ear canal by the hearing assistance device or playing a tone complex into the ear canal by the hearing assistance device.

5 In some embodiments the method further includes modeling the ear canal as a cascade of cylindrical tubes, each tube of the cascade of tubes having a radius and a length, the cascade of tubes including two middle lengths L1 and L2 which are calculated from:  $L1+L2 = (5.81 \times 10^5 - \text{Square Root}[3.38 \times 10^{11} - 7.92 \times 10^7 \times (8450 - f_0)]) / (3.96 \times 10^7)$ , where  $f_0$  is the null frequency; and estimating a series resistance, R, in a middle ear analog using:  $R = (5.92 \times 10^{-3} - \text{Square Root}[3.50 \times 10^{-5} + 1.29 \times 10^{-6} \times (2.78 - Q)]) / (6.46 \times 10^{-7})$ , where Q is the null Q.

The present subject matter also provides a hearing assistance device for measuring sound pressure level in an ear canal of a wearer's ear to provide an estimation of the sound pressure level at a tympanic membrane of the wearer's ear including a high frequency range according to claim 10.

15 In various embodiments the sound sampling apparatus comprises a thin tube having a first end adapted to receive sound in the ear canal and a second end adapted to fit in a microphone port of the hearing assistance device. In various embodiments the sound sampling apparatus comprises a microphone fitted with a small sound tube and wherein the sound emitter is a receiver.

This summary is an overview of some of the teachings of the present application and is not intended to be an exclusive or exhaustive treatment of the present subject matter. Further details about the present subject matter are found in the detailed description and the appended claims. The scope of the present invention is defined by the appended claims.

#### BRIEF DESCRIPTION OF THE DRAWINGS

25 FIG. 1 shows a hearing assistance device worn by a person which is adapted to measure sound at the wearer's eardrum by measuring sound at another location in the wearer's ear canal, according to one embodiment of the present subject matter.

FIG. 2 shows a sound sampling apparatus using a thin tube, according to one embodiment of the present subject matter.

FIG. 3 shows some detail of an example of the sampling apparatus in the ear canal, according to various embodiments of the present subject matter.

30 FIG. 4 shows an example of the sampling apparatus in the ear canal, according to various embodiments of the present subject matter.

FIG. 5 illustrates one method for measuring sound at the tympanic membrane of the wearer, according to one embodiment of the present subject matter.

35 FIG. 6 is a PSPICE model of the ear canal analog, according to one embodiment of the present subject matter.

FIG. 7 is a graph of frequency of pressure minimum versus the tube length in the model according to one embodiment of the present subject matter.

FIG. 8 is a middle ear analog showing a series resistance which is used in one process, according to one embodiment of the present subject matter.

- 3 -

FIG. 9 is a graph of the null Q versus the series resistance according to one embodiment of the present subject matter.

FIG. 10 is a PSPICE model of the ear probe analog which models the device plus the probe, according to one embodiment of the present subject matter.

5 FIG. 11 is an ear canal analog, according to one embodiment of the present subject matter.

FIG. 12 is one example of a middle ear analog (Pascal et al, 1998) for use in a system, according to one embodiment of the present subject matter.

#### DETAILED DESCRIPTION

10 The following detailed description of the present invention refers to subject matter in the accompanying drawings which show, by way of illustration, specific aspects and embodiments in which the present subject matter may be practiced. These embodiments are described in sufficient detail to enable those skilled in the art to practice the present subject matter. References to "an", "one", or "various" embodiments in this disclosure are not necessarily to the same embodiment, and such references contemplate more than one embodiment. The following detailed description is, therefore, not to be taken in  
15 a limiting sense, and the scope is defined only by the appended claims.

The sound field in an individual's ear canal is generally more uniform when subjected to low frequency sound because of the longer wavelength. Because of the uniformity, it is assumed that sound pressure levels and phase sensed near the eardrum provide an accurate measure of the sound pressure level and phase at the eardrum. However, the sound field becomes less uniform and more complex as the  
20 eardrum and ear canal are subjected to higher frequency sounds. It is risky and uncomfortable, to measure the sound pressure level at the eardrum by placing a sensor very close to the eardrum. Furthermore, it is difficult to predict the sound pressure level at the eardrum without placing a sensor very close to the eardrum at high frequencies.

The present invention relates to a system for estimating the sound pressure level at the eardrum by  
25 measurement of sound at another location in the ear canal that is easier to reach. The inventors of the present subject matter discovered in their research that the sound pressure level at the eardrum could be accurately estimated by the sound pressure measurement, measurements of the primary null frequency and null Q of the ear canal at a given location away from the eardrum. These measurements are used to estimate the parameters of an electroacoustic analog model of the ear canal. That model can be used to produce the  
30 sound pressure level at the wearer's eardrum based on the sound pressure level at the distant location. This discovery provides a practical way for more accurate measurement of the sound pressure level at the eardrum in devices which can be deployed in hearing assistance devices, such as hearing aids, offered to consumers. Furthermore, this method doesn't require precise knowledge of the individual's ear canal, which makes it feasible for actual products in the field. Thus, an individualized approach is provided to estimating  
35 the sound produced at the tympanic membrane of the wearer.

FIG. 1 shows a hearing assistance device worn by a person which is adapted to measure sound at the wearer's eardrum by measuring sound at another location in the wearer's ear canal, according to one embodiment of the present subject matter. The hearing aid 100 shown in FIG. 1 has electronics in a housing 102 placed behind the wearer's ear or over the wearer's ear 108. Such devices include, but are not limited to,  
40 behind the ear devices which have receivers (also known as speakers) situated in the housing that contains

- 4 -

the electronics. Such devices have ear hooks and sound tubes for delivery of sound from the receiver to the wearer's ear. Such devices also include receiver in the ear designs that have a receiver placed in the ear canal which is connected via wires to the electronics disposed in the housing worn behind or over the ear, such as receiver-in-canal (RIC) or receiver-in-the-ear (RITE) devices. These variations are generally shown as apparatus 104 which is placed in or about the ear canal 106 of the wearer.

Although demonstrated as a behind the ear or over the ear realization of the technology, it is understood that other types of hearing assistance devices can use the present subject matter, including, but not limited to, in-the-ear (ITE), in-the-canal (ITC), or completely-in-the-canal (CIC) type hearing aids. It is understood that other hearing assistance devices not expressly stated herein may fall within the scope of the present subject matter.

Various different sound sampling approaches can be implemented. One type of sound sampling approach is to use a thin sound tube 204 interfaced to a microphone of the hearing assistance device 200. In designs where the microphone is in the housing behind or on the ear, the coupling can be accomplished using a thin tube having a fitting connected to its proximal end that is placed in a microphone port 202 of the device 200, as is shown in FIG. 2 which is one embodiment of a sound sampling apparatus. FIG. 3 shows some detail of an example of the sampling apparatus in the ear canal according to various embodiments of the present subject matter. The distal end of the thin sound tube 304 (shown at position X in FIG. 3) is placed within the ear canal of the wearer 106. In various embodiments, the distal end of the thin tube is placed a distance D from the emitted sound field of the sound tube or receiver in the ear canal.

The sound emitter is shown generally to be emitter 302 in the ear canal 106 in FIG. 3. In various embodiments, the minimum distance D is about 5 mm. Other distances are possible without departing from the scope of the present subject matter.

Another type of sound sampling approach is to use a microphone disposed in the ear canal. Such designs may be implemented in designs with sound delivery tubes or with receivers placed in the canal. Regardless of the particular implementation, the microphone is placed a distance from the sound emitter (tube or receiver). In various embodiments, the minimum distance is about 5 mm. Other distances are possible without departing from the scope of the present subject matter. In one embodiment of the present subject matter, a microphone 404 is fitted with a small sound tube 406 to provide the distance from the sound emitter 402, as demonstrated in FIG. 4.

Regardless of the approach used to measure sound and the particular hearing assistance device configuration, the sound is measured at a location away from the eardrum of the wearer and is used to generate a model of the wearer's ear canal, which in turn is used to calculate the sound pressure level at the eardrum.

FIG. 5 illustrates one method for estimating sound sound pressure level at the tympanic membrane of the wearer, according to one embodiment of the present subject matter.

The sound measurement apparatus is placed in the ear canal of the wearer at canal position X. Sound is generated to determine the frequency at which the primary amplitude null occurs at position X (502), called the "null frequency" or  $F_n$  or  $f_0$ . In one embodiment, the sound is a swept audio sound played into the ear canal by the hearing assistance device. In one embodiment, the sound is a tone complex played into the ear canal by the hearing assistance device. Other sounds may be employed without departing from

- 5 -

the scope of the present subject matter. A "null Q" of the ear canal as measured at position X is determined (504). In one embodiment, the null Q is obtained by dividing the null frequency by a measured width of the amplitude response at the null (as provided by the 3dB levels of the amplitude response at the null). Once the null Q and the null frequency are determined, they are used to estimate the model parameters as set forth  
 5 herein. In one approach the tube length is estimated using the null frequency and the series resistance in the middle ear analog is estimated by matching the measured Q value with the modeled Q value as follows:

(1) TUBE LENGTH: In one embodiment, the tube length can be estimated by matching the measured null frequency and the modeled null frequency as shown in FIG. 6. FIG. 6 is a PSPICE model of the ear canal analog, according to one embodiment of the present subject matter. In FIG. 6, the ear canal is  
 10 modeled as a cascade of cylindrical tubes, which are defined by its radius (Rad) and length (Len). The middle two lengths L1 and L2 are allowed to change. By adjusting the sum of L1 + L2 then we can estimate the proper individualized ear canal values. To reduce the computational cost in practice, the tube length (L1 + L2) can be calculated using the following formula:

$$L1+L2 = (5.81 \times 10^5 - \text{Square Root}[3.38 \times 10^{11} - 7.92 \times 10^7 \times (8450 - f_0)]) / (3.96 \times 10^7),$$

15 where  $f_0$  is the null frequency. FIG. 7 is a graph of frequency of pressure minimum versus the tube length in the model according to one embodiment of the present subject matter. It demonstrates the model results (denoted by squares) and the curve fit (line).

(2) SERIES RESISTANCE: In one embodiment, the series resistance in the middle ear analog is estimated by matching the measured Q value and the modeled Q value as shown in the following figure  
 20 using the middle ear analog from Pascal, Jerome and Bourgeade, Antoine (1998). "Linear and nonlinear model of the human ear," J. Acoust. Soc. Am. 104 (3) 1509, which is incorporated by reference in its entirety herein and is referenced herein as "Pascal et al, 1998." The middle ear analog as demonstrated by FIG. 8 is taken from Pascal et al, 1998. FIG. 8 is a middle ear analog showing a series resistance which is used in one process, according to one embodiment of the present subject matter. In the model of FIG. 8, the  
 25 effective area of the eardrum is about 0.55 cm<sup>2</sup>, the total area is about 0.85 cm<sup>2</sup>, the thickness is about 0.01 cm (1.1 gm/cm<sup>3</sup>), and total mass is about 9.35mg. Other dimensions and masses may be modeled without departing from the scope of the present subject matter and the numbers provided herein are intended to be demonstrative and not exhaustive or exclusive or otherwise limiting.

To reduce the computational cost in practice, the series resistance can be calculated using the  
 30 following formula:

$$R = (5.92 \times 10^{-3} - \text{Square Root}[3.50 \times 10^{-5} + 1.29 \times 10^{-6} \times (2.78 - Q)]) / (6.46 \times 10^{-7}),$$

where Q is the null Q. FIG. 9 is a graph of the null Q versus the series resistance according to one embodiment of the present subject matter. The model results (shown as diamonds) and curve fit (line) are shown.

35 FIG. 5 illustrates one method for measuring sound at the tympanic membrane of the wearer, according to one embodiment of the present subject matter. Sound is measured at position X (506). The sound at the tympanic membrane is determined as a function of the sound sampled by the sound measurement apparatus at position X, the null frequency and Q, (508). In one embodiment, the formula to produce the sound pressure level at the tympanic membrane is:

- 6 -

Estimated dB SPL at TM= Actual dB SPL at position X+ [Modeled dB SPL at TM - Modeled dB SPL at position X].

A detailed model is demonstrated as shown in FIG. 10. The ear probe analog of FIG. 10 is a PSPICE model which models the device plus the probe according to one embodiment of the present subject matter. Therefore, in one embodiment it models: a Knowles receiver (TWFK30017) (which is just one example of a receiver, thus other receivers may be modeled without departing from the teachings of the present application), a receiver tubing, and a probe tube that was threaded through a vent.

FIG. 11 is an ear canal analog, according to one embodiment of the present subject matter. The ear canal analog includes the cascade of tubes as described above in FIG. 6, and in particular the two tubes having lengths L1 and L2 and the tubes on either side with  $LEN = 0.002$ . In various embodiments, 0 to 4 mm segments are compliant cavity not tube. Therefore, 4mm offset from Stinson data may be used in various embodiments. The example of FIG. 11 is only one of many possible models and is intended to demonstrate the present subject matter. It is not intended in an exhaustive, exclusive or otherwise limiting sense.

FIG. 12 is one example of a middle ear analog (Pascal et al, 1998) for use in a system according to one embodiment of the present subject matter. In the model of FIG. 12 the effective area of the eardrum is about  $0.55 \text{ cm}^2$ , the total area is about  $0.85 \text{ cm}^2$ , the thickness is about  $0.01 \text{ cm}$  ( $1.1 \text{ gm/cm}^3$ ), and total mass is about  $9.35 \text{ mg}$ . Other dimensions and masses may be modeled without departing from the scope of the present subject matter and the numbers provided herein are intended to be demonstrative and not exhaustive or exclusive or otherwise limiting.

In one embodiment, the present approach is implemented in the fitting software and the hearing device. In alternate embodiments, the present system is implemented completely in the hearing device.

In various embodiments, the present subject matter provides a method for estimating the sound pressure level at a tympanic membrane in an ear canal of an ear of a wearer of a hearing assistance device using measurements away from the tympanic membrane according to claim 1.

Variations of the foregoing methods include wherein placing a sound sampling apparatus comprises placing a thin tube with an end at the first position for sampling sound at the first position. Variations further include placing a second end of the thin tube in a microphone port of the hearing assistance device. Variations include wherein placing a sound sampling apparatus comprises placing a microphone at the first position. In some variations the sound sampling apparatus is a microphone fitted with a small sound tube and wherein the sound emitter is a receiver. In some embodiments the first position and the second position have a minimum distance of about  $5 \text{ mm}$ . Different ways of emitting sound include, but are not limited to playing a swept audio sound into the ear canal by the hearing assistance device or playing a tone complex into the ear canal by the hearing assistance device.

In some embodiments the method further includes modeling the ear canal as a cascade of cylindrical tubes, each tube of the cascade of tubes having a radius and a length, the cascade of tubes including two middle lengths L1 and L2 which are calculated from:  $L1+L2 = (5.81 \times 10^5 - \text{Square Root}[3.38 \times 10^{11}-7.92 \times 10^7 \times (8450-f_0)]) / (3.96 \times 10^7)$ , where  $f_0$  is the null frequency; and estimating a series resistance, R, in a middle ear analog using:  $R = (5.92 \times 10^{-3} - \text{Square Root}[3.50 \times 10^{-5} + 1.29 \times 10^{-6} \times (2.78 - Q)])/(6.46 \times 10^{-7})$ , where Q is the null Q.

The present subject matter also provides a hearing assistance device for measuring sound pressure level in an ear canal of a wearer's ear to provide an estimation of the sound pressure level at a tympanic membrane of the wearer's ear including a high frequency range according to claim 10.

5 In various embodiments the sound sampling apparatus comprises a thin tube having a first end adapted to receive sound in the ear canal and a second end adapted to fit in a microphone port of the hearing assistance device. In various embodiments the sound sampling apparatus comprises a microphone fitted with a small sound tube and wherein the sound emitter is a receiver.

10 It is understood that the embodiments provided herein are to demonstrate the calculations, but that differences in order of the determinations or minor variations in the model of the ear canal can be made without departing from the scope of the present subject matter.

The present subject matter includes hearing assistance devices, including, but not limited to, cochlear implant type hearing devices, hearing aids, such as behind-the-ear (BTE), in-the-ear (ITE), in-the-canal (ITC), completely-in-the-canal (CIC), and receiver-in-the-canal (RIC) type hearing aids. It is understood that behind-the-ear type hearing aids may include devices that reside substantially behind the ear  
15 or over the ear. Such devices may include hearing aids with receivers associated with the electronics portion of the behind-the-ear device, or hearing aids of the type having receivers in-the-canal (RIC) or receiver-in-the-ear (RITE). It is understood that other hearing assistance devices not expressly stated herein may fall within the scope of the present subject matter.

20 This application is intended to cover adaptations and variations of the present subject matter. It is to be understood that the above description is intended to be illustrative, and not restrictive. The scope of the present subject matter is defined by the appended claims.

SYSTEM TIL BESTEMMELSE AF NIVEAUET FOR LYDTRYK VED TROMMEHINDEN VED  
ANVENDELSE AF MÅLINGER VÆK FRA TROMMEHINDEN

## PATENTKRAV

1. Fremgangsmåde til bestemmelse af niveauet for lydtryk ved en trommehinde i en øregang i et øre  
5 hos en bruger af en hørehjælpsanordning ved anvendelse af målinger væk fra trommehinden, hvilken fremgangsmåde anvender hørehjælpsanordningen og omfatter:
  - placering af et apparat til lydsampling i øregangen ved en første position;
  - placering af en lydsender i øregangen ved en anden position;
  - generering af lyd med lydsenderen og modtagelse af lyd med apparatet til lydsampling for at måle  
10 et amplituderespons i øregangen, kendetegnet ved at omfatte
    - bestemmelse af nulfrekvensen ved den første position ud fra amplituderesponset i øregangen;
    - bestemmelse af bredden af amplituderesponset ved nulfrekvensen, således som det er tilvejebragt af amplituderesponsets 3 dB niveauer;
    - bestemmelse af nul Q ved at dividere nulfrekvensen med bredden af amplituderesponset;
- 15
  - modellering af øregangen enten i form af en kaskade af cylindriske rør eller i form af en analog model af mellemøret omfattende en seriemodstand,
    - eller bestemmelse af længden af to mellemliggende rør af modellen af kaskaderør ved anvendelse af nulfrekvensen eller bestemmelse af seriemodstanden for den analoge model af mellemøret ved anvendelse af nul Q ved matchning af nul Q med modelleret Q;
- 20
  - bestemmelse af niveauet for det modellerede lydtryk ved trommehinden ved anvendelse af enten kaskaderøret eller de analoge modeller af mellemøret; og
    - vurdering af niveauet for lydtryk ved trommehinden ved anvendelse af følgende formel:  
vurderet niveau for lydtryk i dB ved trommehinden = reelt niveau for lydtryk i dB ved den første  
25 position + [modelleret niveau for lydtryk i dB ved trommehinden – modelleret niveau for lydtryk i dB ved den første position].
2. Fremgangsmåde ifølge krav 1, hvor placering af et apparat til lydsampling omfatter placering af et rør med en ende ved den første position for lydsampling ved den første position.
3. Fremgangsmåde ifølge krav 2, hvilken fremgangsmåde endvidere omfatter placering af en anden ende af røret i en mikrofonåbning til hørehjælpsanordningen.
- 30 4. Fremgangsmåde ifølge krav 1, hvor placering af et apparat til lydsampling omfatter placering af en mikrofon ved den første position.
5. Fremgangsmåde ifølge krav 1, hvor apparatet til lydsampling er en mikrofon, der er udstyret med et lydør, og hvor lydsenderen er en modtager.
6. Fremgangsmåde ifølge et hvilket som helst af de foregående krav, hvor den første position og den  
35 anden position har en minimal adskillelsesafstand på ca. 5 mm.
7. Fremgangsmåde ifølge et hvilket som helst af de foregående krav, hvilken fremgangsmåde endvidere omfatter frembringelse af en lyd med frekvens-sweep i øregangen ved hjælp af hørehjælpsanordningen.

8. Fremgangsmåde ifølge et hvilket som helst af kravene 1 til 7, hvilken fremgangsmåde endvidere omfatter frembringelse af et tonekompleks i øregangen ved hjælp af hørehjælpsanordningen.
9. Fremgangsmåde ifølge et hvilket som helst af de foregående krav, hvilken fremgangsmåde omfatter enten
- 5 modellering af øregangen i form af kaskaden af cylindriske rør, hvor hvert rør i kaskaden af rør har en radius og en længde, hvilken kaskade af rør indbefatter de to mellemliggende rør med længderne L1 og L2 i meter, der er beregnet ud fra:
- $$L1 + L2 = (5,81 \times 10^5 - \text{kvadratrod}[3,38 \times 10^{11} - 7,92 \times 10^7 \times (8450 - f_0)])/(3,96 \times 10^7),$$
- hvor  $f_0$  er nulfrekvesen i Hz; eller
- 10 vurdering af en seriemodstand R, i ohm, i den analoge model af mellemøret ved anvendelse af følgende formel:
- $$R = (5,92 \times 10^{-3} - \text{kvadratrod}[3,50 \times 10^{-5} + 1,29 \times 10^{-6} \times (2,78 - Q)])/(6,46 \times 10^{-7}),$$
- hvor Q er nul Q.
10. Hørehjælpsanordning (100) til måling af et niveau for lydtryk i en øregang i øret på en bærer for at
- 15 tilvejebringe en vurdering af niveauet for lydtryk ved en trommehinde i øret på bæreren indbefattende et højt frekvensinterval, hvilken hørehjælpsanordning omfatter:
- et hus (102), der er tilpasset til at blive båret af bæreren;
- et apparat til lydsampling (304), der gør det muligt at måle lyd i øregangen ved en første position væk fra trommehinden;
- 20 et lydsender (302) i øregangen ved en anden position; og
- en processor, der står i forbindelse med lydsenderen og apparatet til lydsampling, kendetegnet ved, at processoren er tilpasset til at udføre instruktioner med henblik på:
- bestemmelse af nulfrekvesen ved den første position ud fra amplituderesonset fra øregangen;
- bestemmelse af bredden af amplituderesonset ved nulfrekvesen, således som det tilvejebringes af
- 25 amplituderesonsets 3 dB niveauer;
- bestemmelse af nul Q ved at dividere nulfrekvesen med bredden af amplituderesonset;
- modellering af øregangen enten i form af en kaskade af cylindriske rør eller en analog model af mellemøret omfattende en seriemodstand,
- eller bestemmelse af længden af to mellemliggende rør i modellen af kaskaderør ved anvendelse af
- 30 nulfrekvesen eller bestemmelse af seriemodstanden for den analoge model af mellemøret ved anvendelse af nul Q ved matchning af nul Q med modelleret Q;
- bestemmelse af niveauet for det modellerede lydtryk ved trommehinden ved anvendelse af enten kaskaderøret eller de analoge modeller af mellemøret; og
- vurdering af lydniveauet ved trommehinden ved anvendelse af følgende formel:
- 35 vurderet niveau for lydtryk i dB ved trommehinden = reelt niveau for lydtryk i dB ved den første position + [modelleret niveau for lydtryk i dB ved trommehinden – modelleret niveau for lydtryk i dB ved den første position].

- 10 -

11. Hørehjælpsanordning ifølge krav 10, hvor apparatet til lydsampling omfatter et rør (304), der har en første ende, der er tilpasset til at modtage lyd i øregangen og en anden ende, der er tilpasset til at tilpasses i en mikrofonåbning (202) i hørehjælpsanordningen.
12. Hørehjælpsanordning ifølge krav 10, hvor apparatet til lydsampling omfatter en mikrofon, der er  
5 udstyret med et lydrør, og hvor lydssenderen er en modtager.

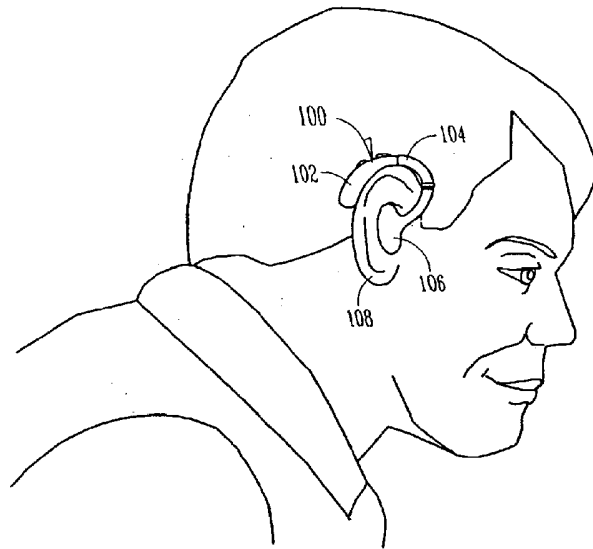

*Fig. 1*

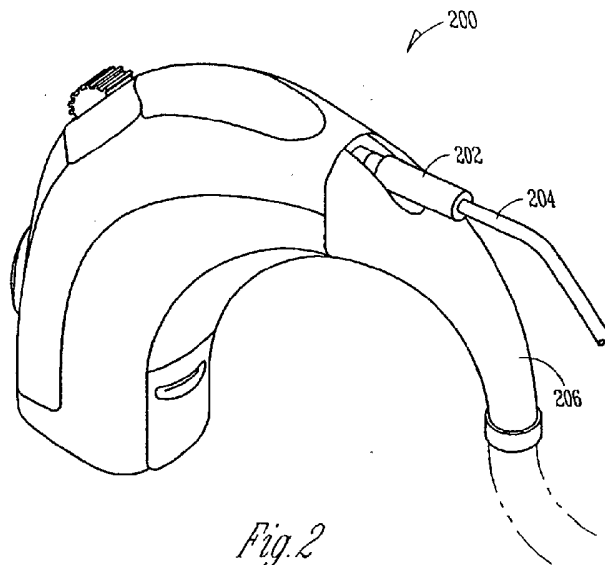

*Fig. 2*

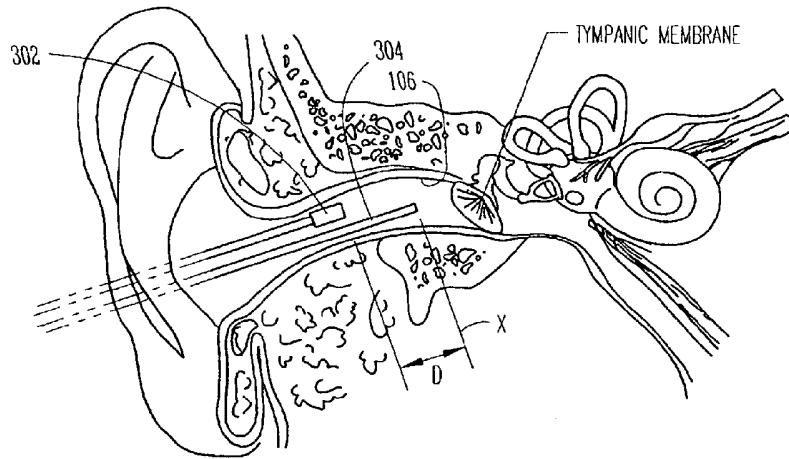

*Fig. 3*

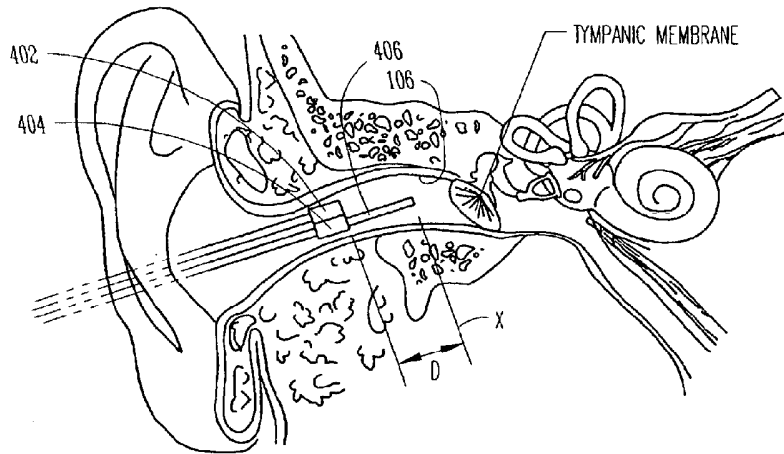

*Fig. 4*

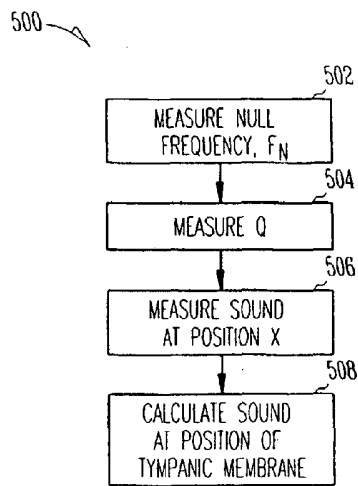

Fig. 5

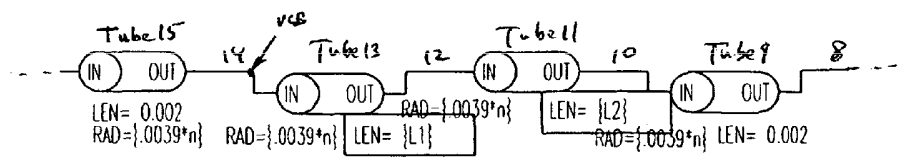

Fig. 6

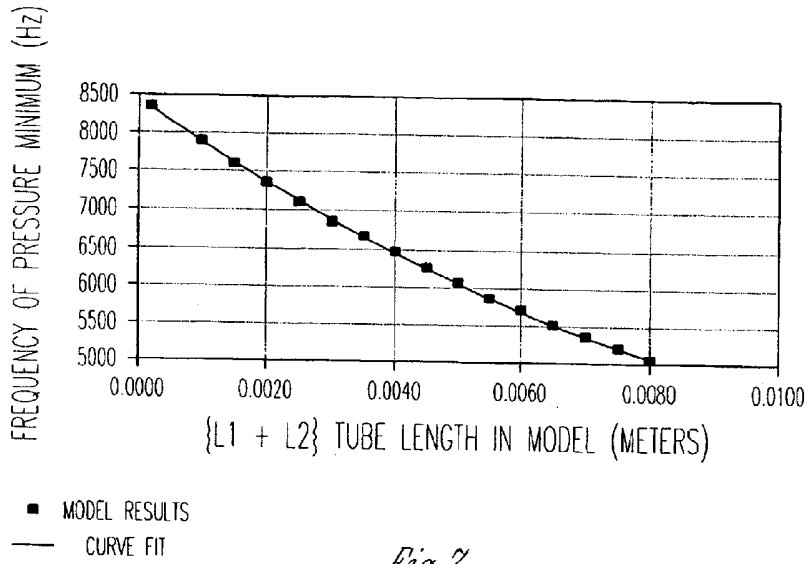

Fig. 7

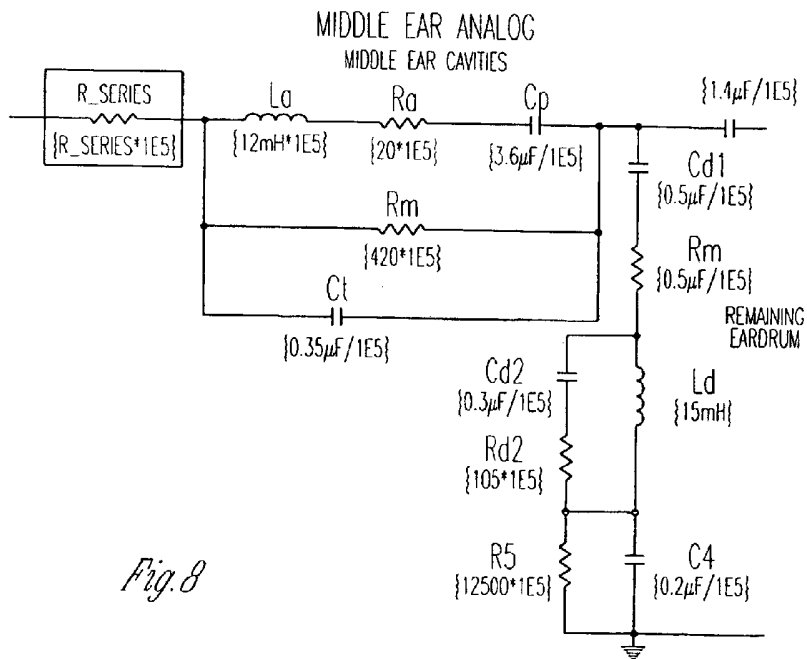

Fig. 8

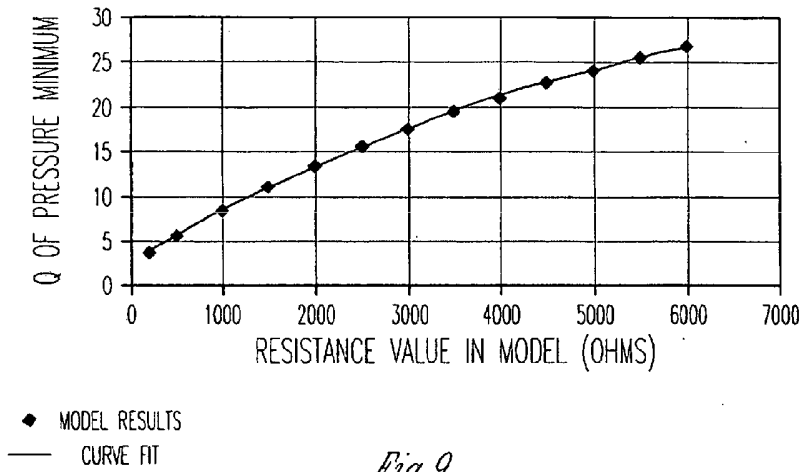

Fig. 9

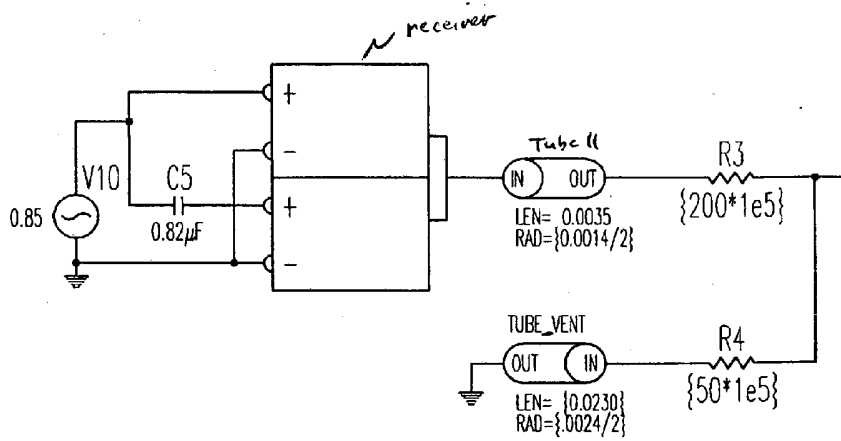
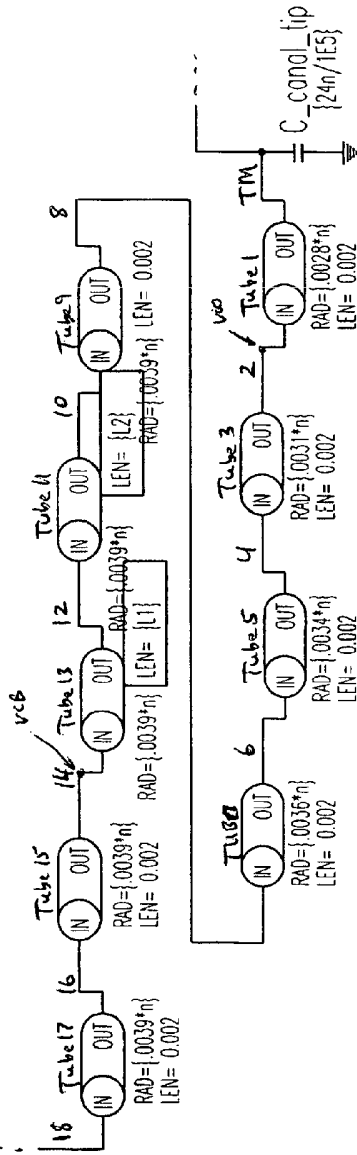

Fig. 10



TF FITTING PARAMETERS

PARAMETERS	ORIGINAL ESTIMATE	ESTIMATE
R_SERIES	1785	1785
L1	.0020	.0020
L2	.0020	.0020

VOLUME ESTIMATE = 34nF  
 ORIGINAL ESTIMATE = 24nF  
 AVERAGE 10 SUBJECTS R=1785

Fig. 11

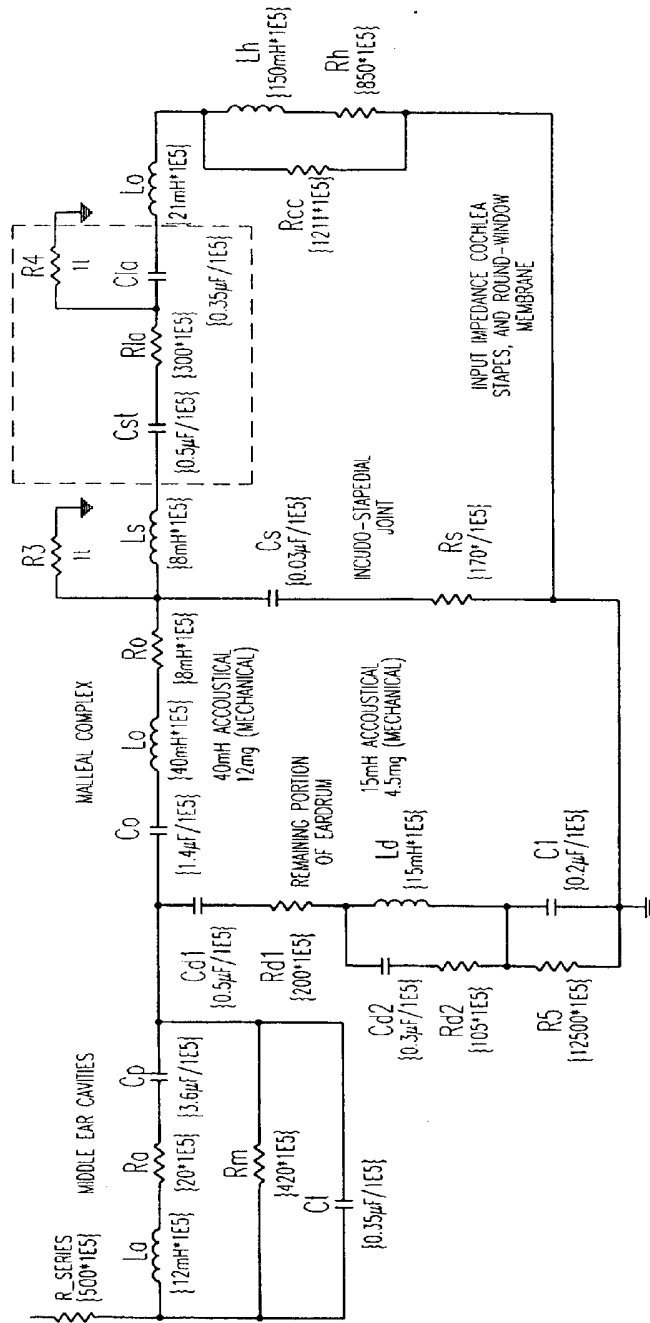

Fig. 12