

H. U. Petin,
Rolling Tires.

No. 107,194.

Patented Sept. 6, 1870.

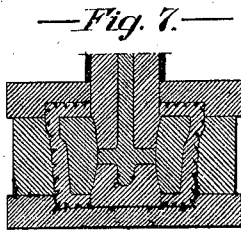
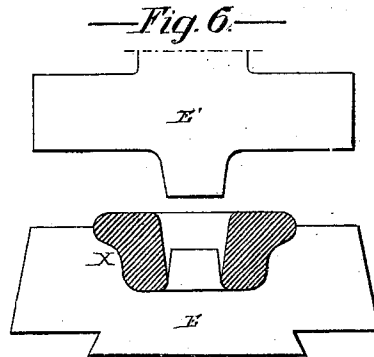
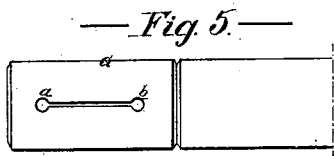
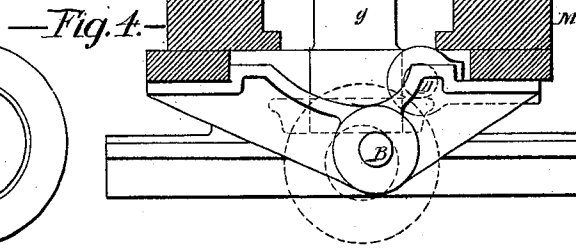
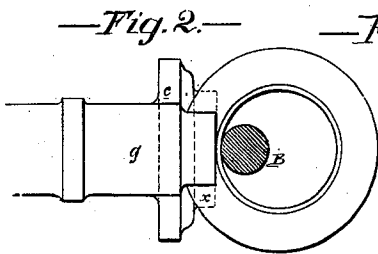
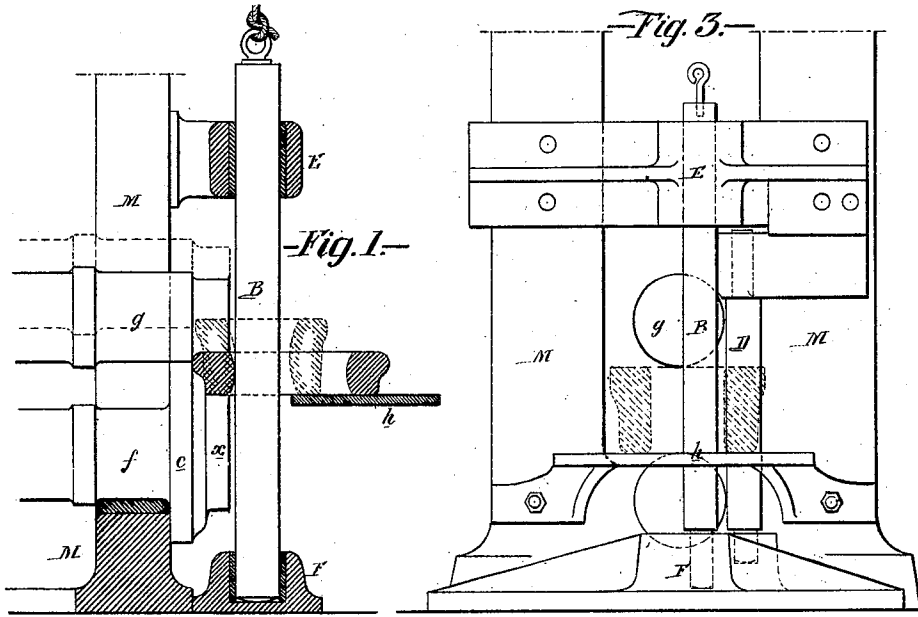

Witnesses { *Wm. A. Steel*
John Parker

Hippolyte U. Petin
by his attys
Howson and Son

United States Patent Office.

HIPPOLYTE ULYSSE PETIN, OF RIVE DE GIER, FRANCE.

Letters Patent No. 107,194, dated September 6, 1870

IMPROVEMENT IN MACHINES FOR ROLLING TIRES.

The Schedule referred to in these Letters Patent and making part of the same

I, HIPPOLYTE ULYSSE PETIN, of the firm of Hte. Petin, Gaudet & Co., metallurgist, of Rive de Gier, in the Empire of France, have invented an Improved Machine for Rolling Metal Tires, &c., of which the following is a specification.

Nature and Objects of the Invention.

My invention relates to the manufacture of Tires, &c., from rings of forged or cast metal; and

My invention consists of a machine, in which the said rings are subjected to the action of certain rollers and a mandrel, operating as fully described hereafter, so as to compressively act upon every face of the rings.

Description of the Accompanying Drawing.

Figure 1 is a sectional view of the machine;
Figure 2, a sectional plan view;
Figure 3, an elevation, showing a modification;
Figure 4, a sectional plan of fig. 3;
Figures 5 and 6, views illustrating ordinary modes of manufacturing tires, &c.; and
Figure 7, a sectional view, illustrating one mode of making the rough metal ring or blank, from which the tire is to be formed.

General Description.

In suitable bearings turn two parallel metal rollers, *f g*, the bearings of the lower roller, *f*, being fixed, and those of the upper roller sliding vertically between guides in the frame *M* of the machine, and to the front end of the roller *f* is secured a disk, *c*, the edge of which, in the present instance, is of the form shown in fig. 1.

The projecting end of the roll *g*, directly above the disk *c*, is reduced in diameter, for a purpose described hereafter, and to the frame *M* of the machine is secured a rest or platform, *h*, which occupies a position in front of the disk *c*, and level with the horizontal face *x* of a projecting portion of said disk.

In an arm, *E*, projecting from the frame *M*, and in a step, *F*, at the base of the machine, turns a vertical mandrel, *B*, which is secured at the upper end to a cord or other device, by which it can be elevated, so as to withdraw it from its position in front of the disk *c*, and between the latter and the plate *h*.

Before proceeding to describe my improvement, I will first briefly refer to the ordinary modes of manufacturing heavy tires and similar articles, and the disadvantages resulting from these modes, which I overcome by my improvement.

In some instances an ingot, *G*, (fig. 5,) is pierced at two points, *a b*, and is slit between these points, and a series of mandrels is forced successively into the slit, widening the latter gradually, so as to form a single ring. This is then rounded on a mandrel by a trip-hammer, and reduced as nearly as possible to a uniform thickness.

Another mode consists in casting a ring, *X*, of steel,

(fig. 6,) and then stamping or pressing the ring between dies *E E'*, repeating the method whenever it is necessary. The ring is then rolled between the rollers, pressing against the inner and outer edges only.

Both of these operations are tedious and expensive, and fail to reduce the ring to that perfectly uniform thickness desired.

To overcome these difficulties I first form a ring either by welding from a fagot or by casting. In the latter case I use a flask, the sections of which are serrated at the inner sides, as shown in fig. 7, so as to retain the sand, the ring being deeper or higher than those used in the ordinary modes of manufacture.

The ring thus obtained is then heated and placed upon the platform *h*, one edge resting on the projection *x* of the disk *c*, the end of the roller *g* resting on the opposite edge of the ring, and the mandrel *B* extending through the same, as shown in figs. 1 and 2; a rotary motion is then imparted to the rollers, when the ring will be caused to revolve between the bearing surfaces of the same, which press upon all the faces of the ring, the weight of the roller *g* gradually reducing the height of the ring, and pressing it against the edge of the disk *c*, which forms the outer face, constituting the edge or tread of the tire.

By thus operating with revolving rollers on all the faces of the ring at one time, the operation of reducing it to the proper form is speedily accomplished with little labor and expense, and the product is more uniform in shape and better in quality than that from the ordinary process of manufacture.

The disk *c* may in some cases be dispensed with, and the ring may be compressed directly between the projecting ends of both rollers *f g*, an additional vertical mandrel, *D*, being used, as shown in figs. 3 and 4.

After the operation is completed the mandrel *B* is removed and the ring withdrawn, and, if necessary, subjected to such other operation as may be required to complete it.

If required, the roller *g* may be forced against the ring by a screw or other device, instead of by its weight.

Claim.

The rolls *f g*, the projecting outer ends of which are constructed to form the sides and tread of a tire, in combination with the roll *B* for rolling the inside of the tire, when the said roll is arranged substantially as herein shown and described, so as to be removed through the tire.

In testimony whereof I have signed my name to this specification in the presence of two subscribing witnesses.

HIPPOLYTE ULYSSE PETIN. [L. s.]

Witnesses:

EMILE REISSARD,
J. U. ZUST.