



US 20080296183A1

(19) **United States**
(12) **Patent Application Publication**
Meers

(10) **Pub. No.: US 2008/0296183 A1**
(43) **Pub. Date: Dec. 4, 2008**

(54) **TRAY AND DOLLY**

Publication Classification

(76) Inventor: **Ryan C. Meers**, Los Angeles, CA (US)

(51) **Int. Cl.** *B65D 69/00* (2006.01)
(52) **U.S. Cl.** **206/232; 280/29**

Correspondence Address:
CARLSON, GASKEY & OLDS, P.C.
400 WEST MAPLE ROAD, SUITE 350
BIRMINGHAM, MI 48009 (US)

(57) **ABSTRACT**

A container includes a card holder having a flap portion for retaining a card against the exterior of one wall of the container. The card holder is snap-fit to the wall and pivotable relative to the wall. The flap portion is biased against the wall in order to retain the card. A complementary dolly includes a deck having recesses for receiving the casters of a similar dolly stacked thereon. The recesses automatically align rotatable casters as they are inserted.

(21) Appl. No.: **11/754,458**

(22) Filed: **May 29, 2007**

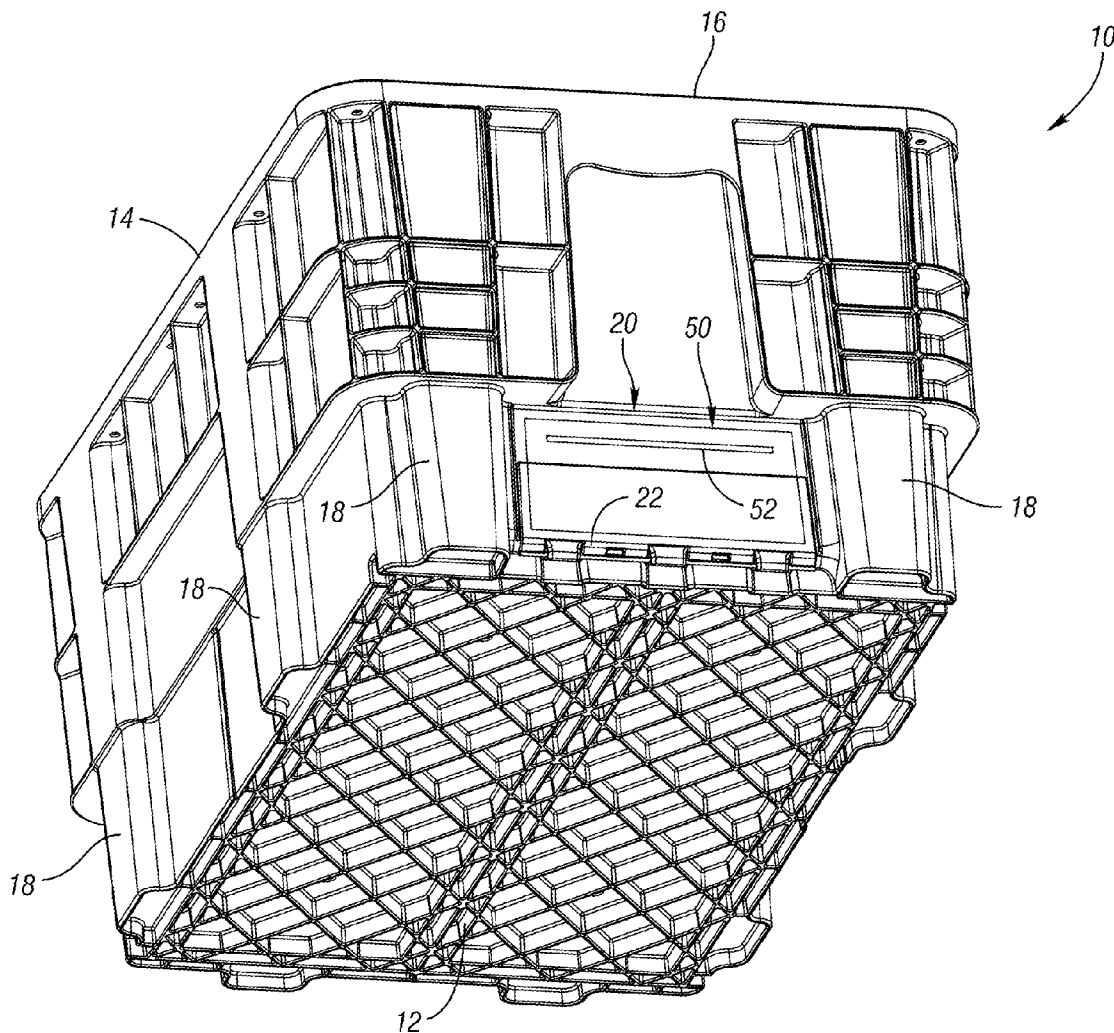

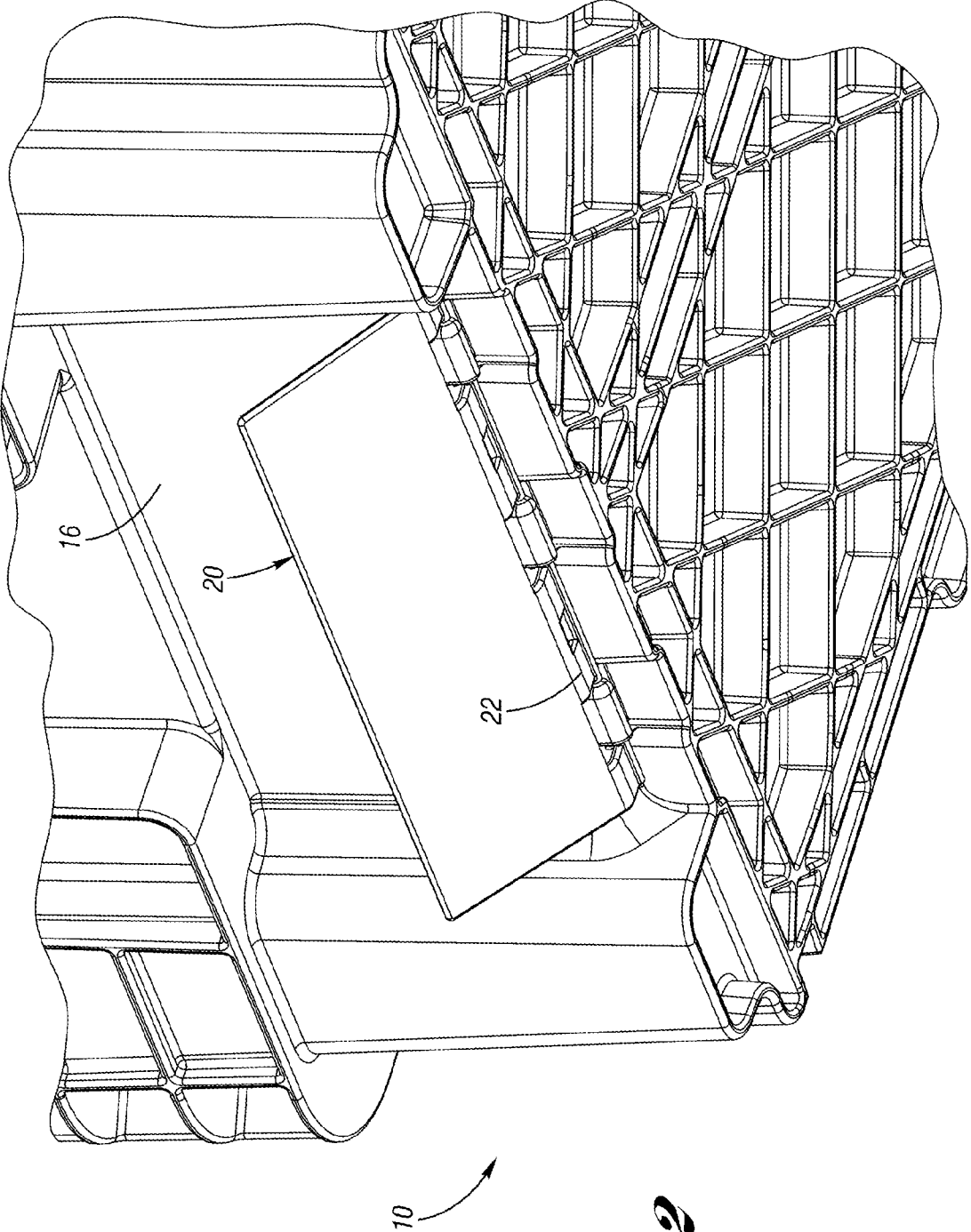

Fig. 2

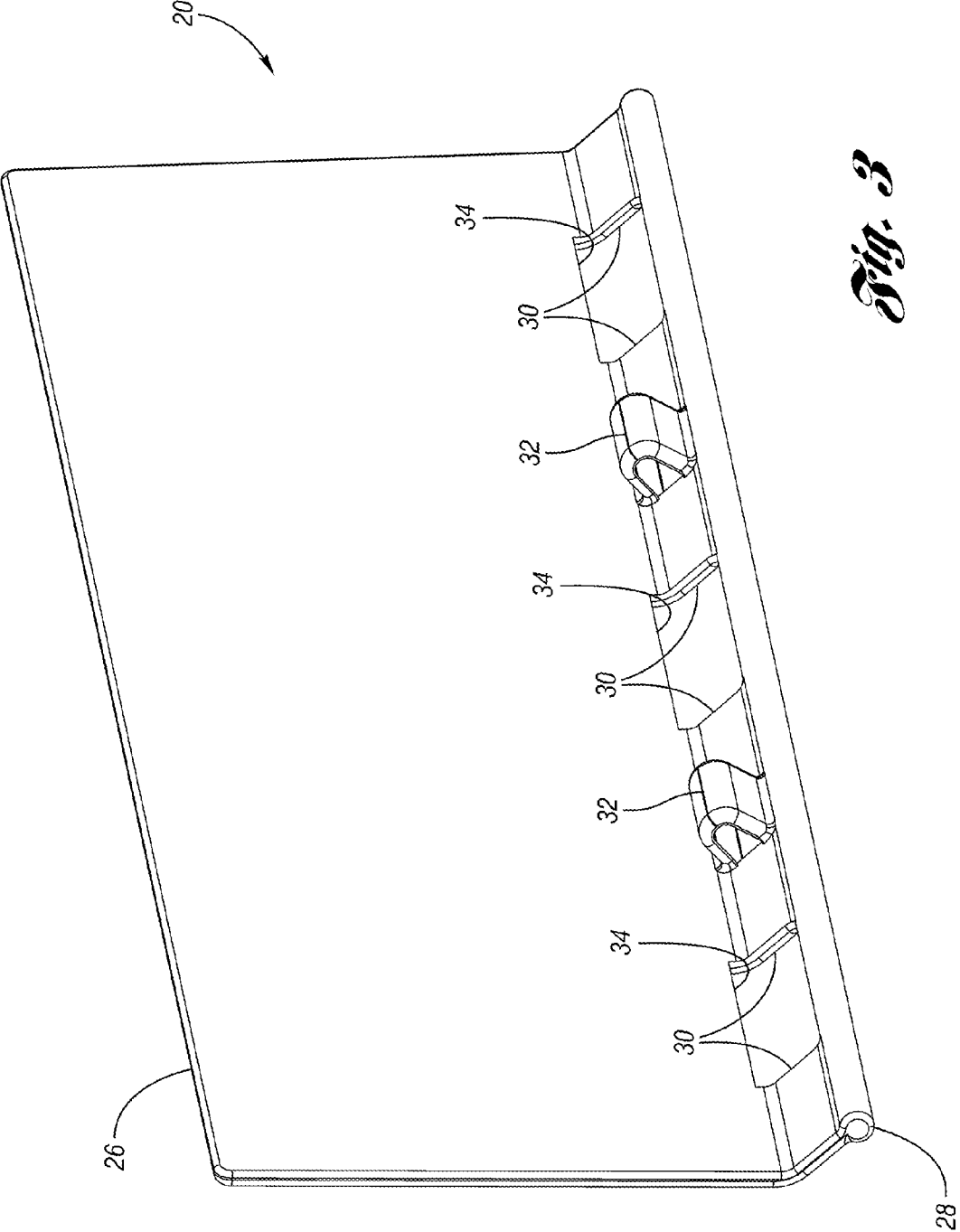

Fig. 3

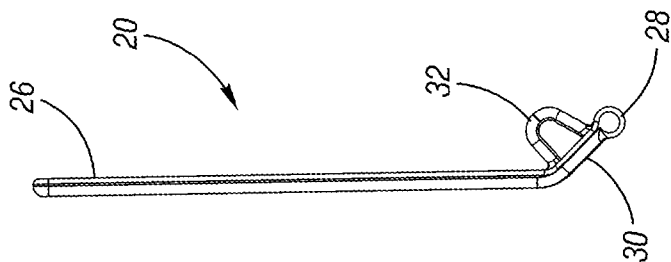

Fig. 5

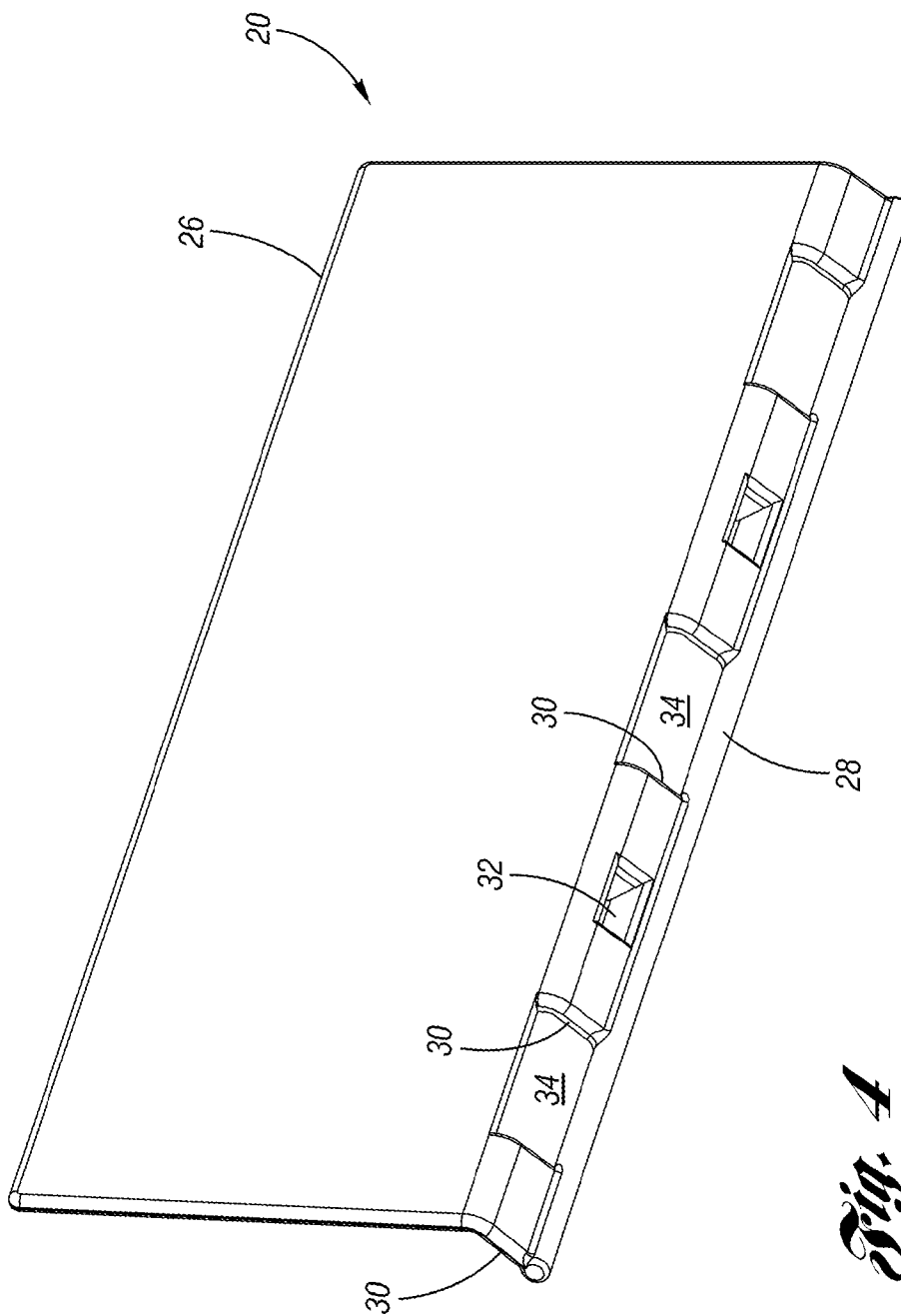

Fig. 4

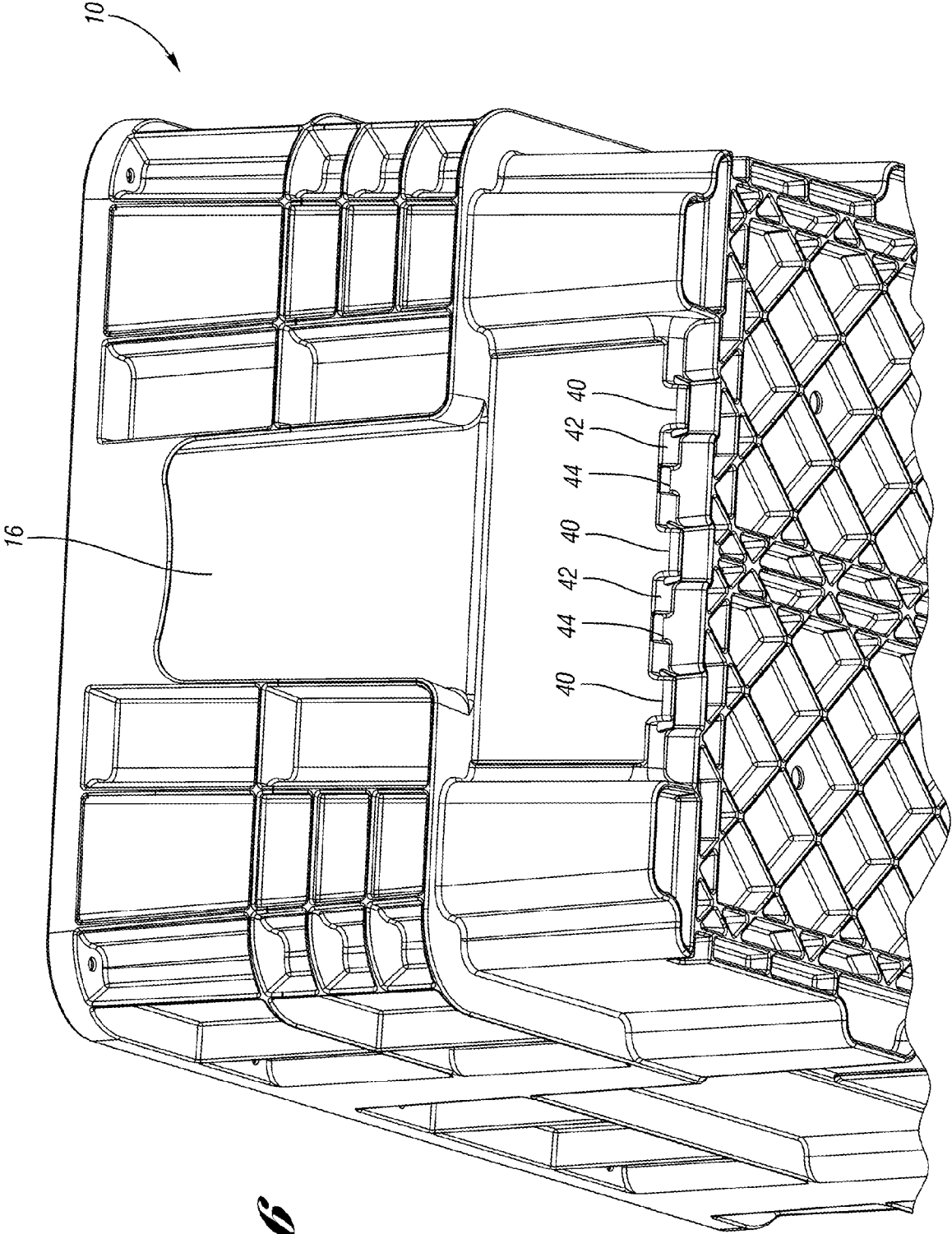

Fig. 6

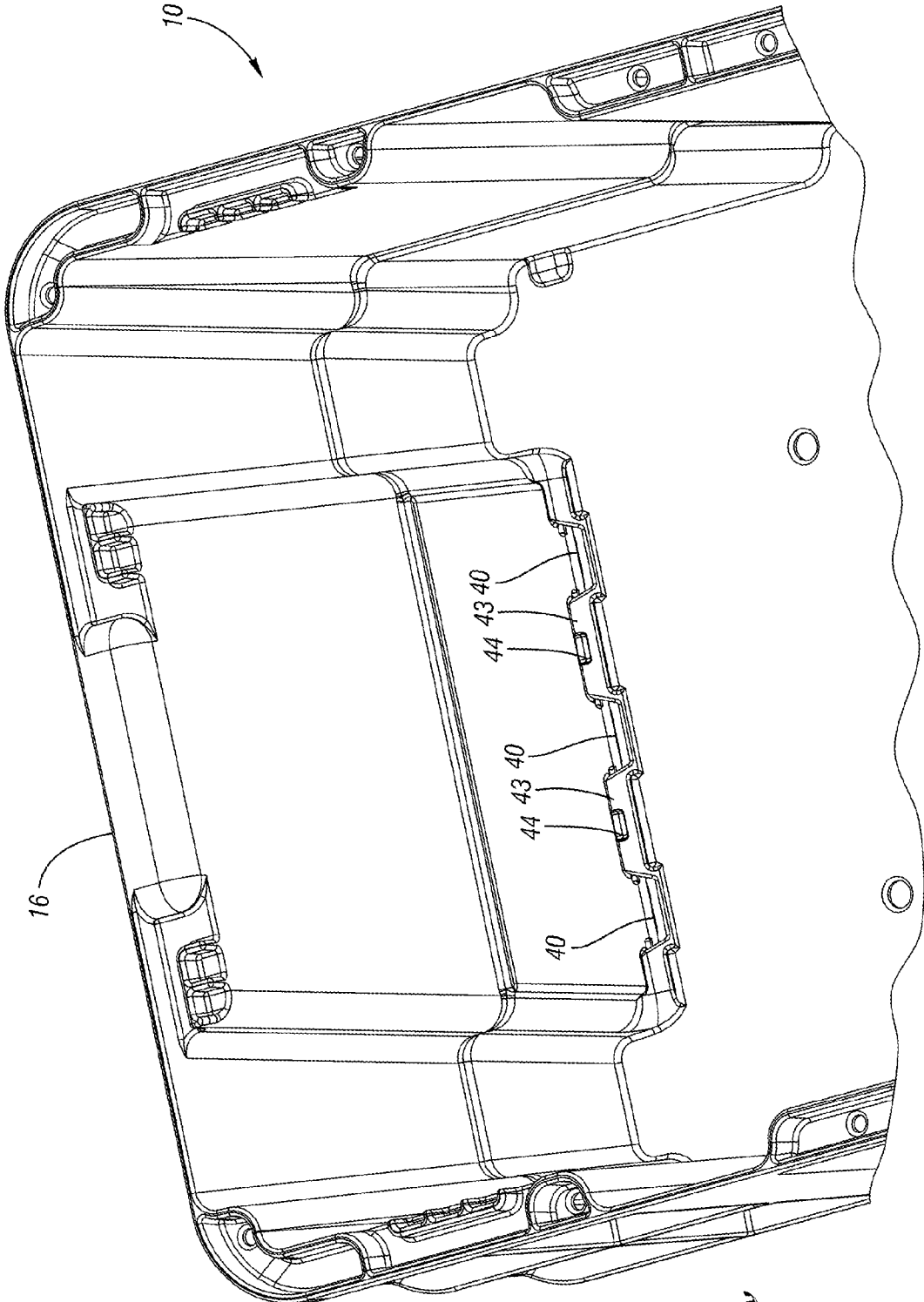

Fig. 7

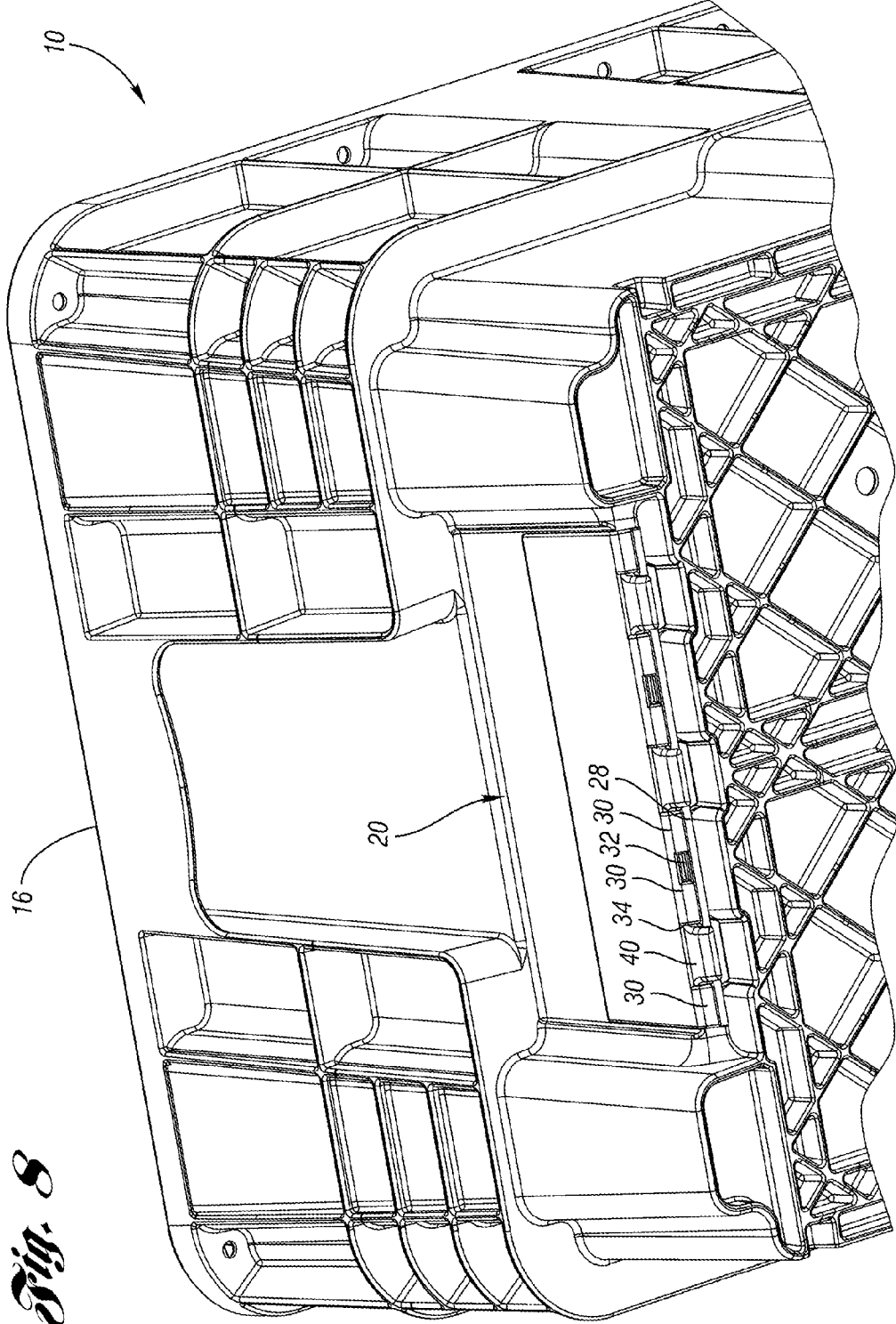

Fig. 8

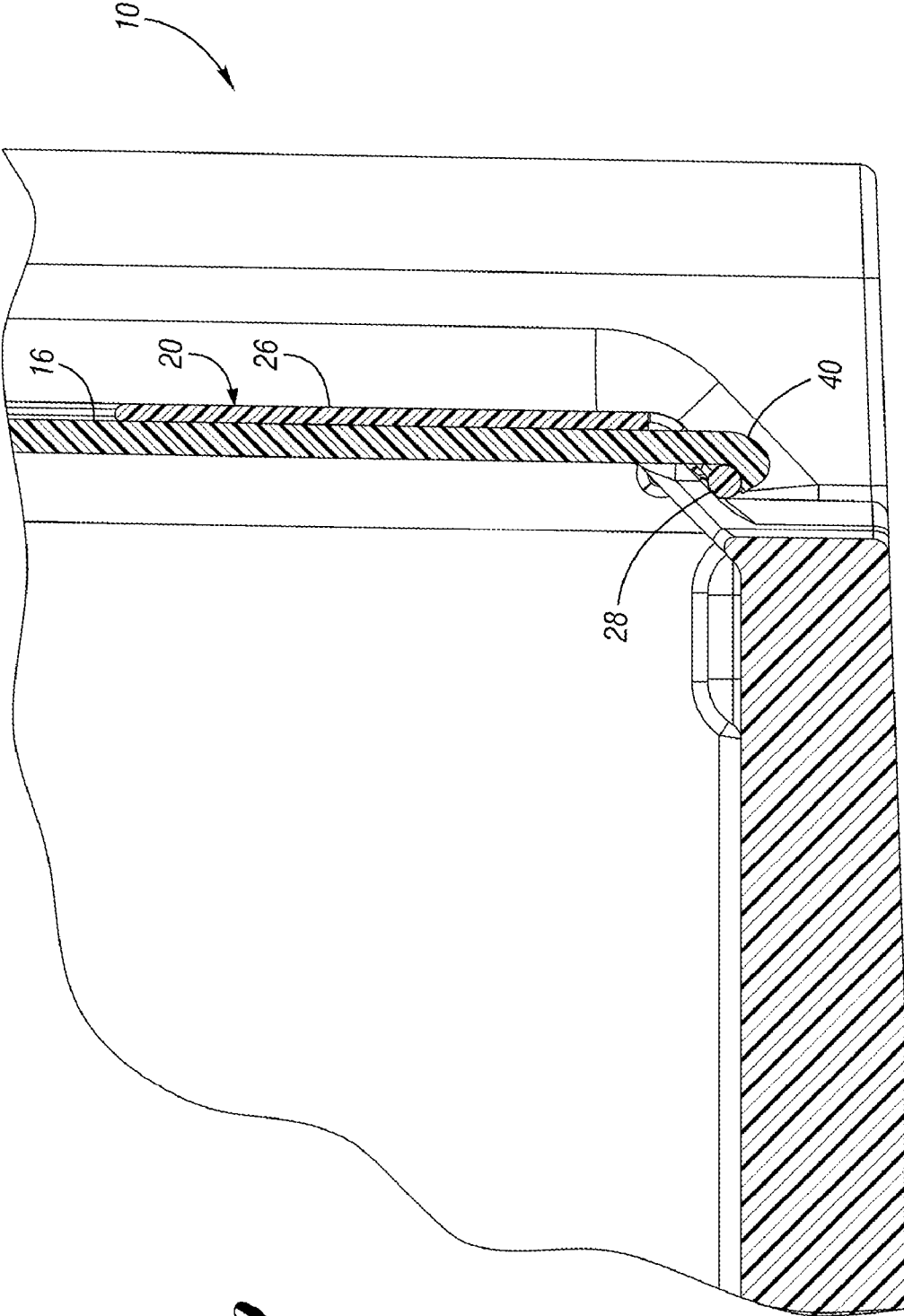

Fig. 9

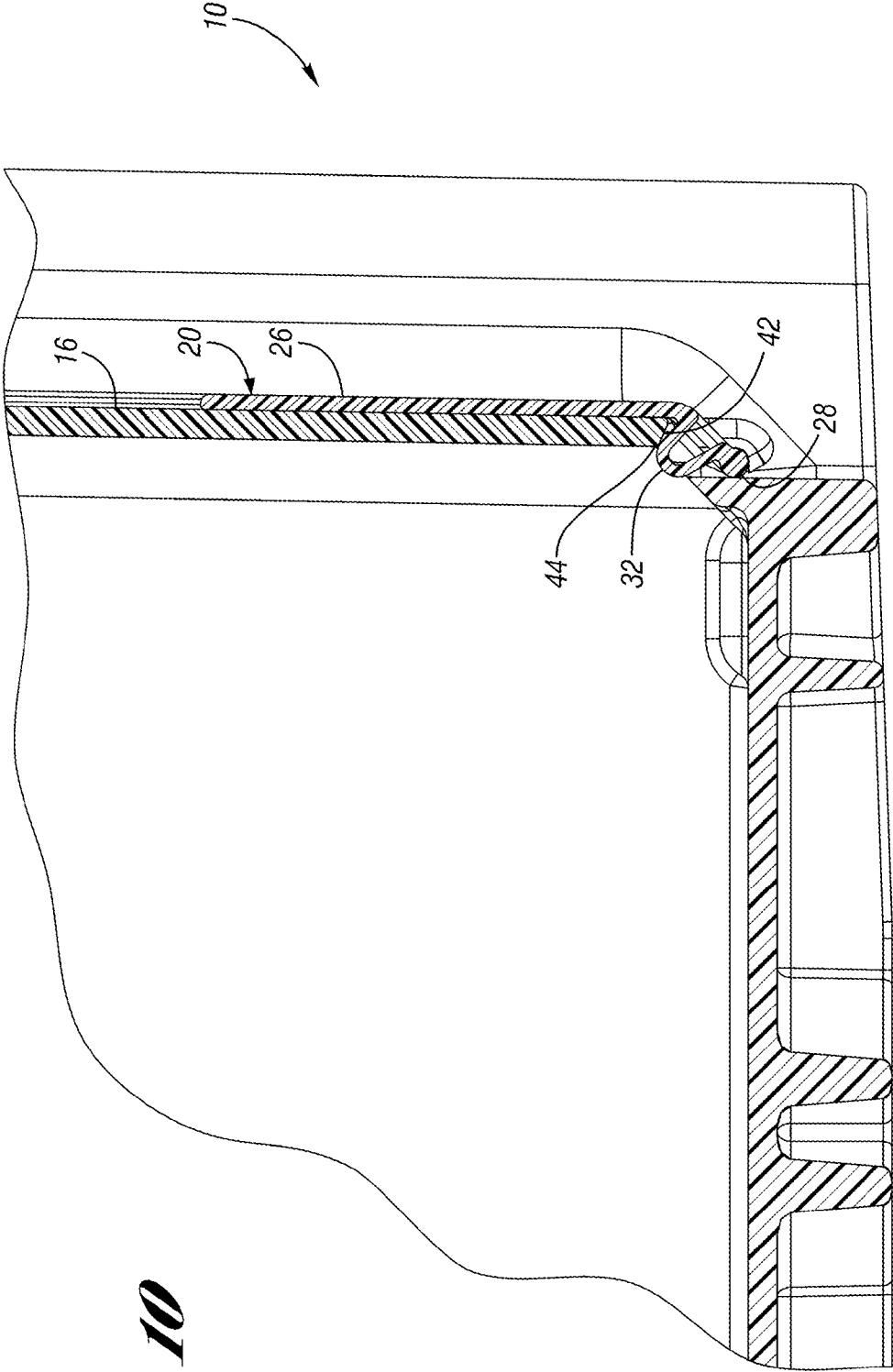

Fig. 10

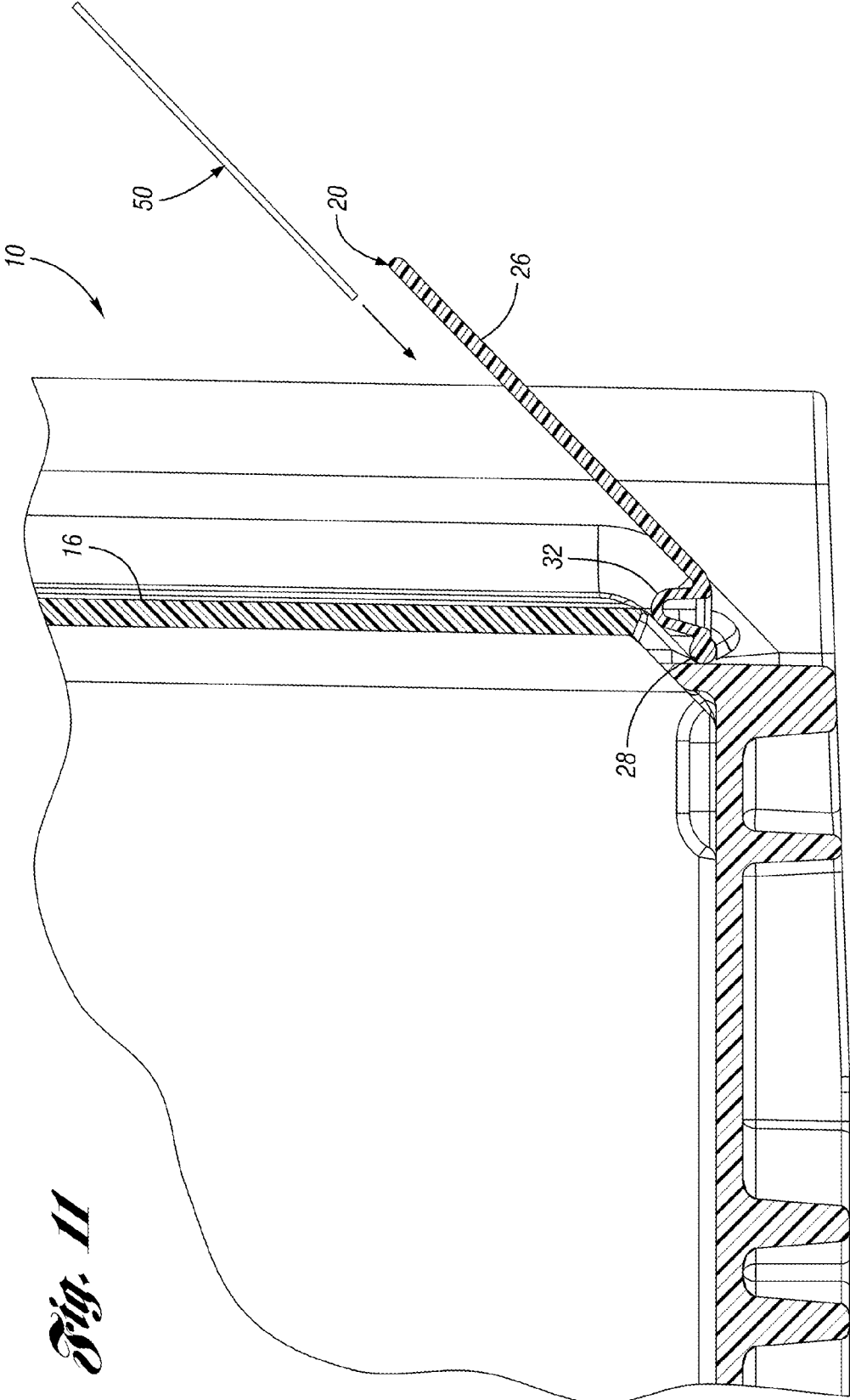

Fig. 11

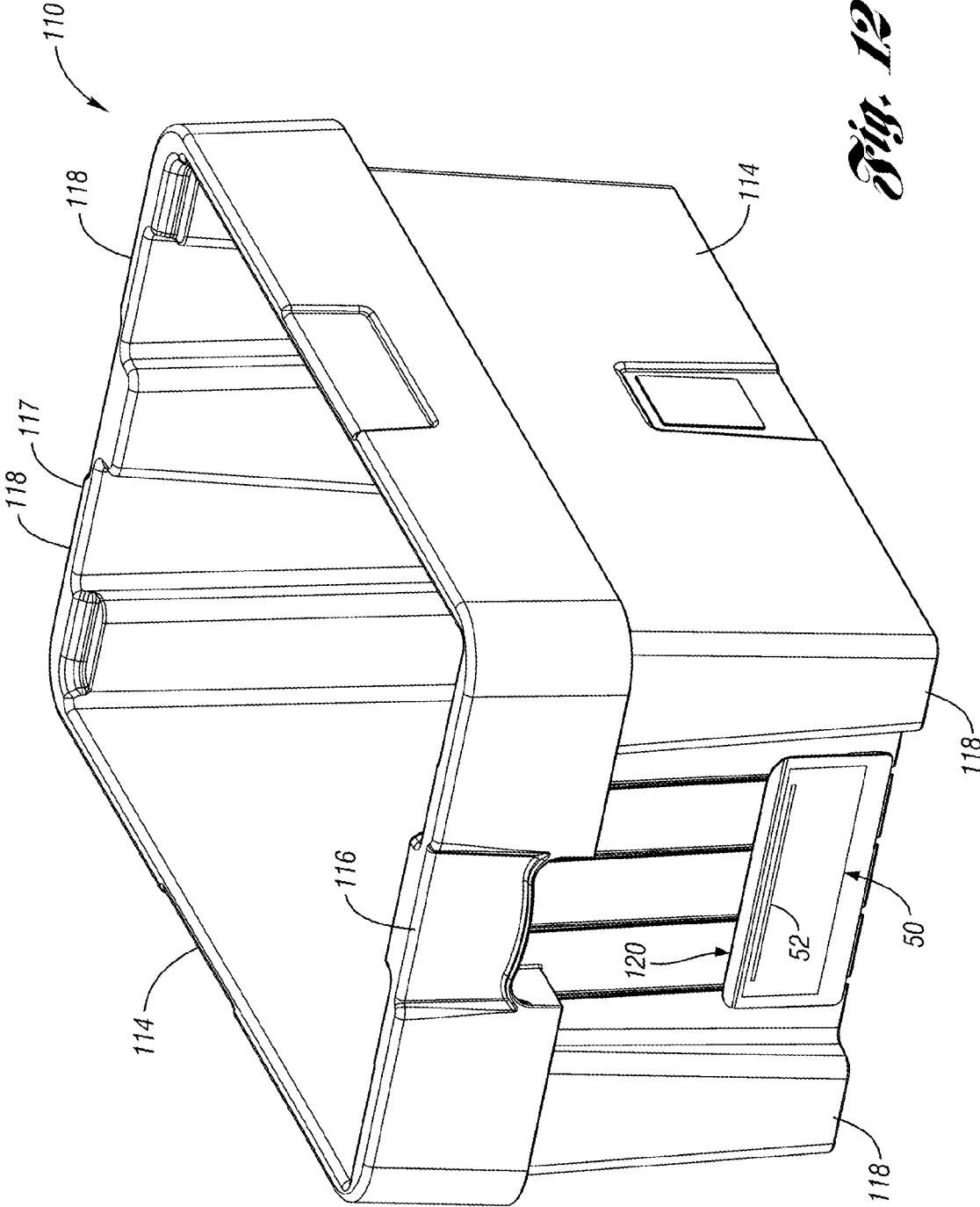

Fig. 12

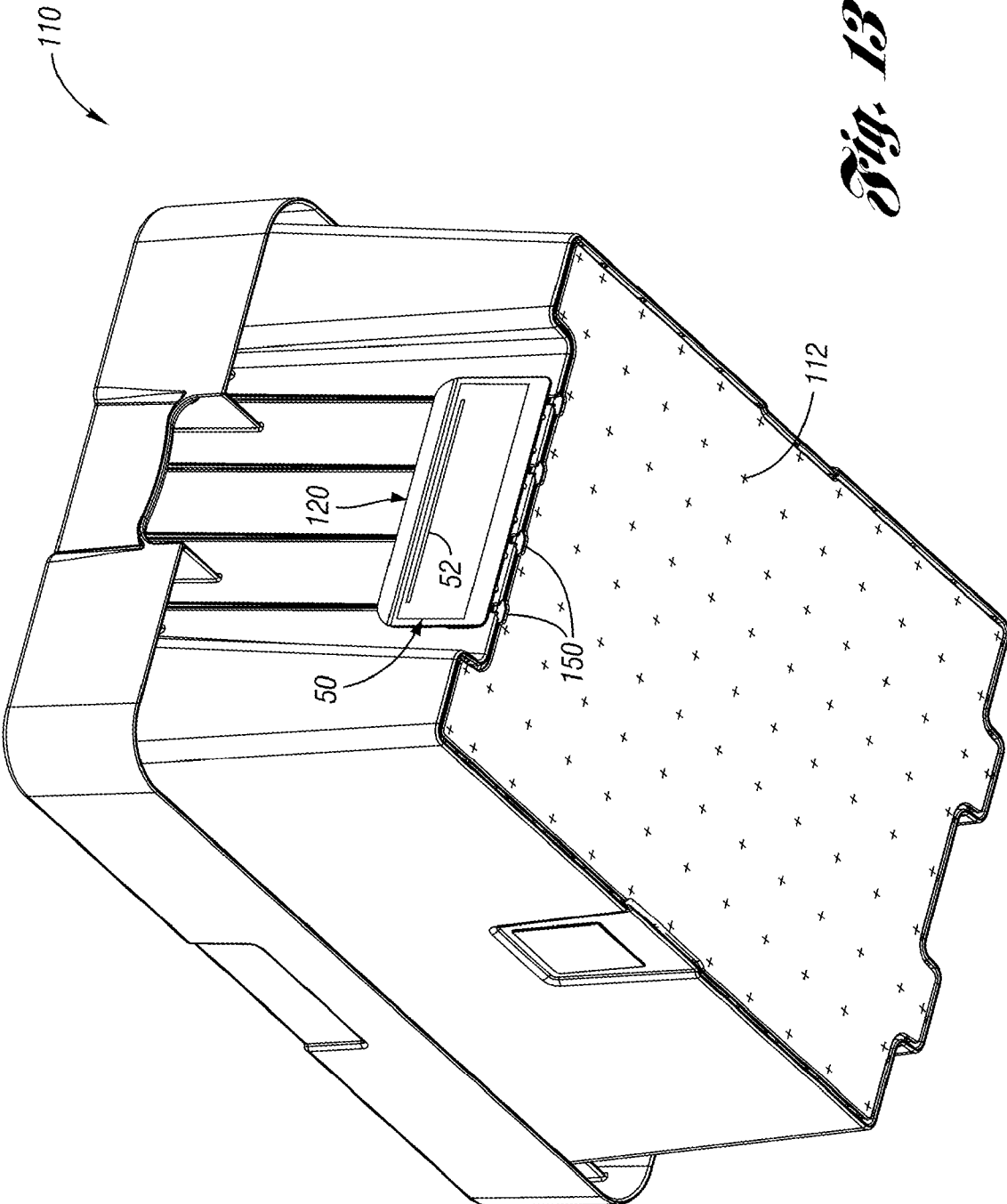
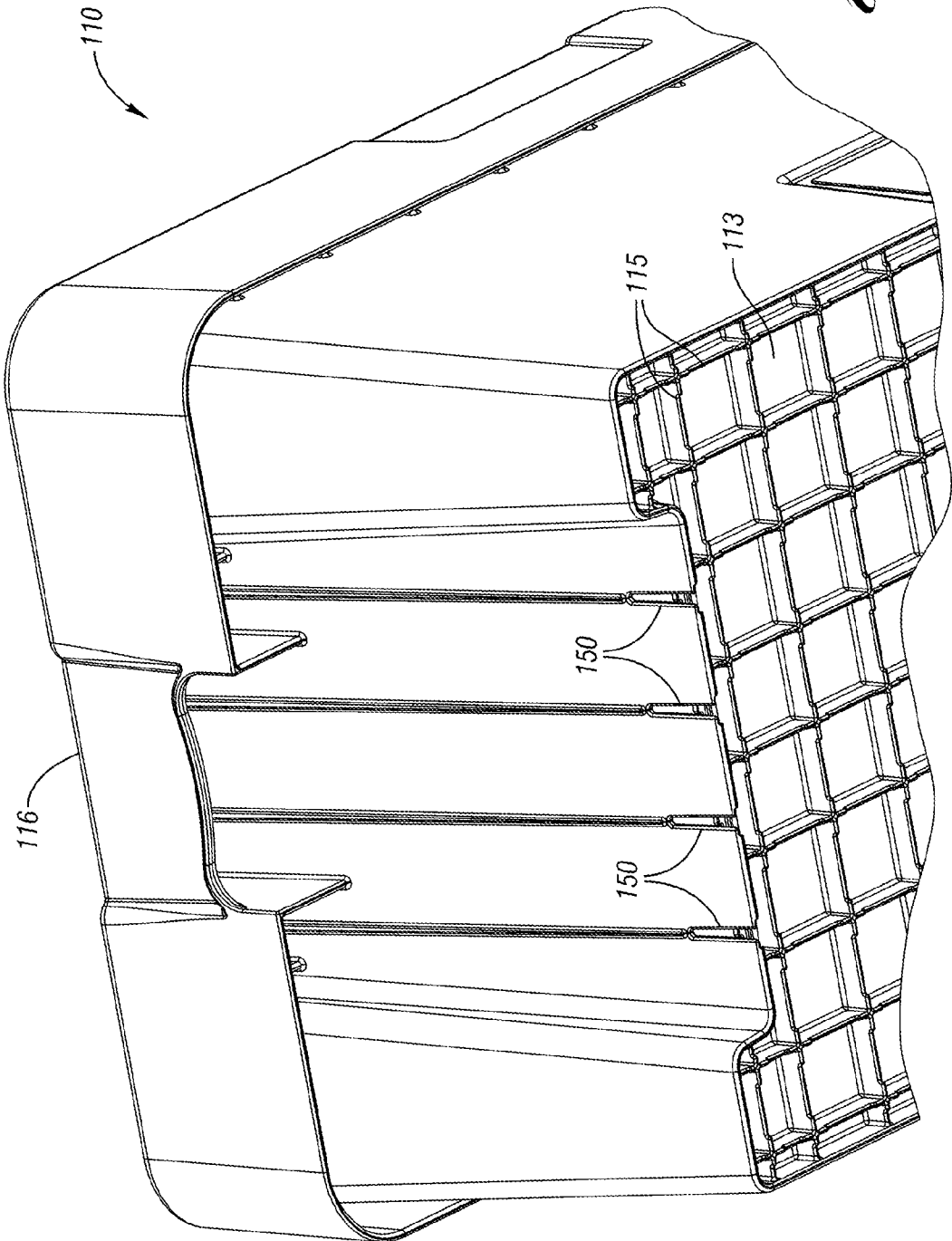

Fig. 13

Fig. 1A



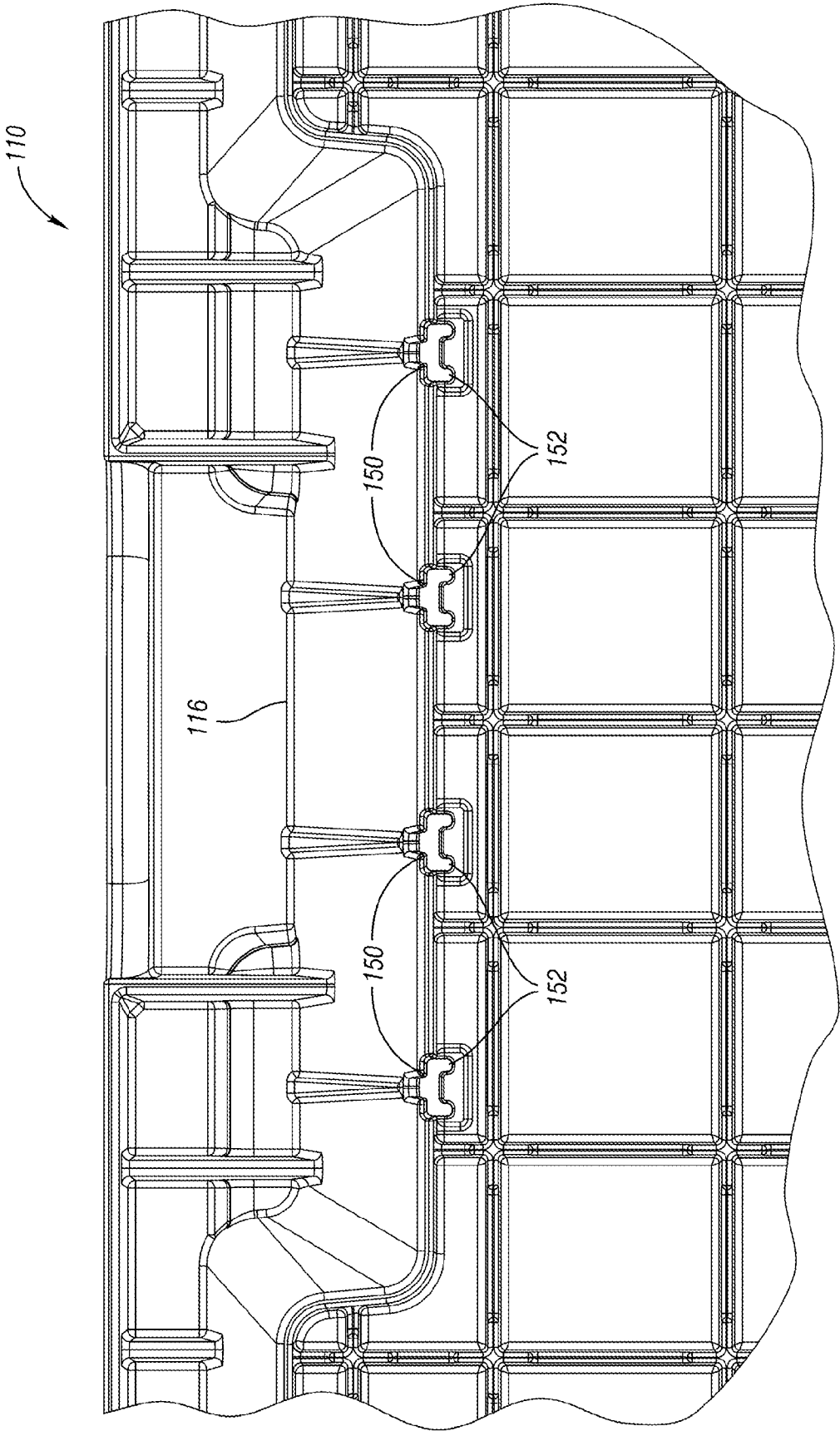

Fig. 15

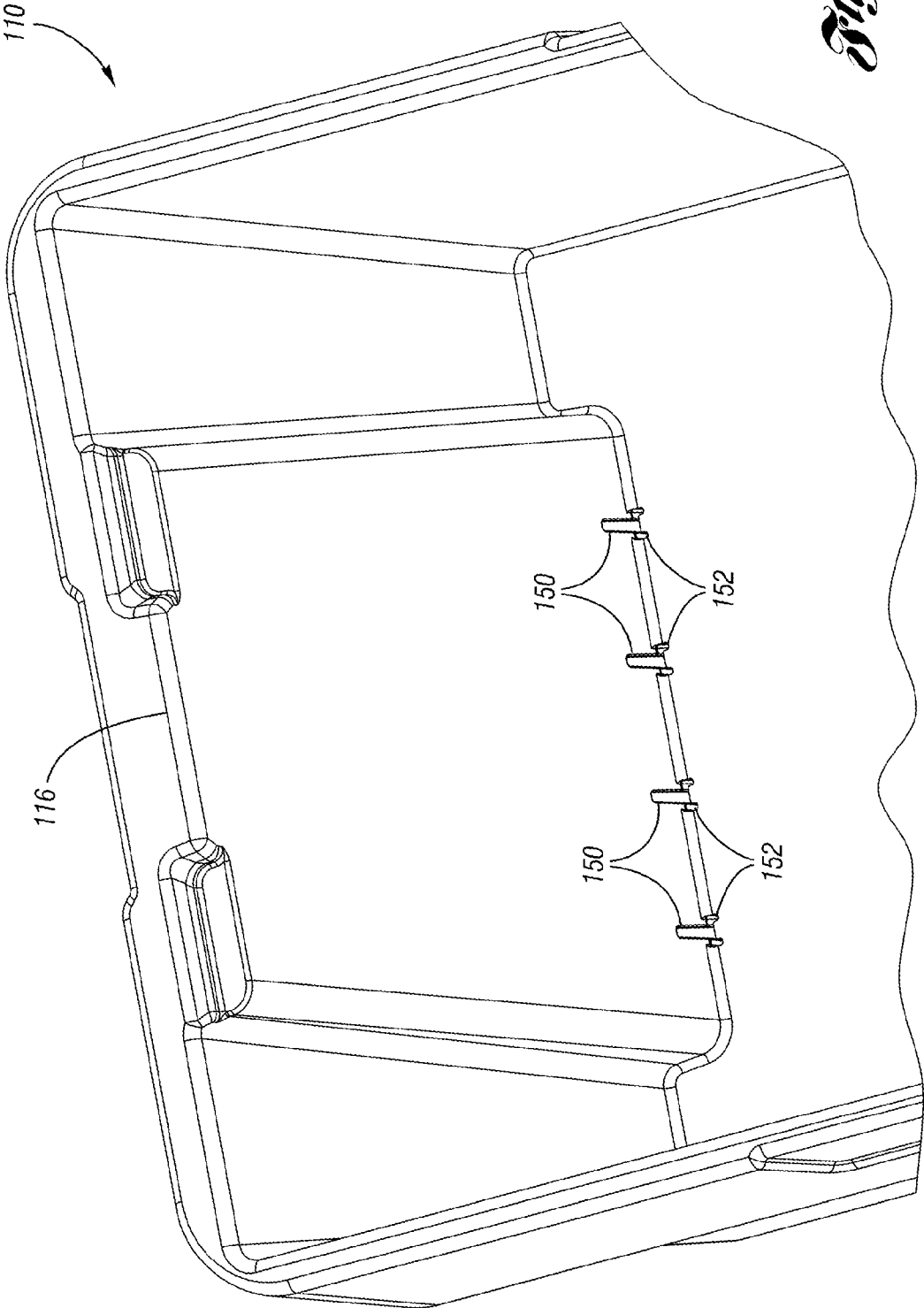

Fig. 16

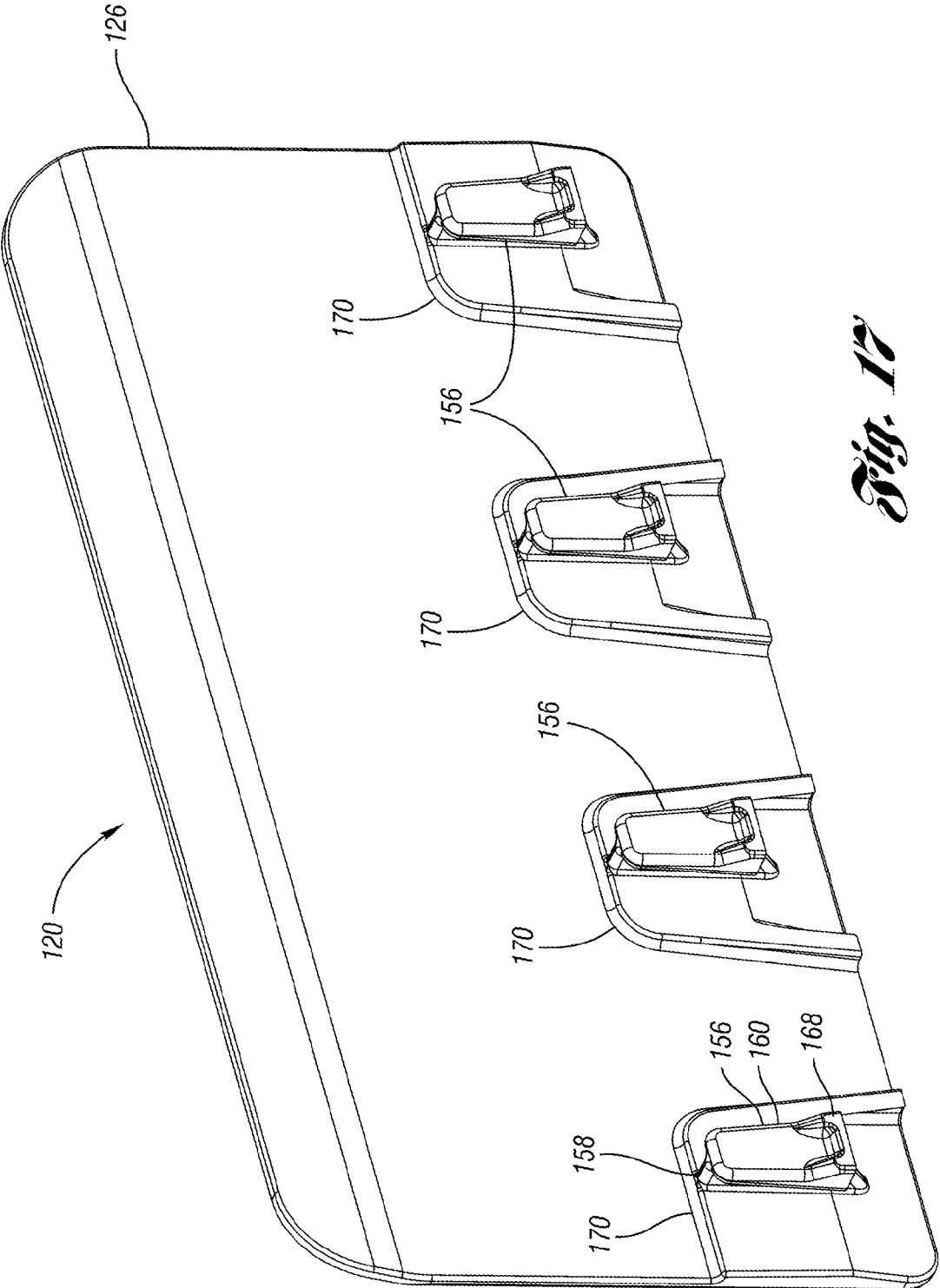

Fig. 17

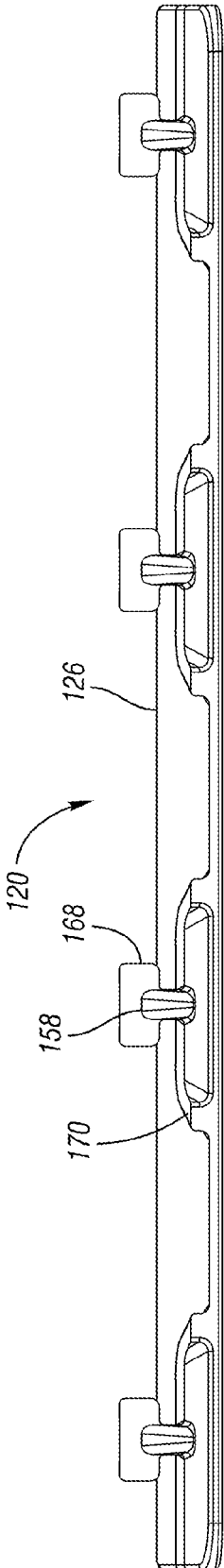

Fig. 18

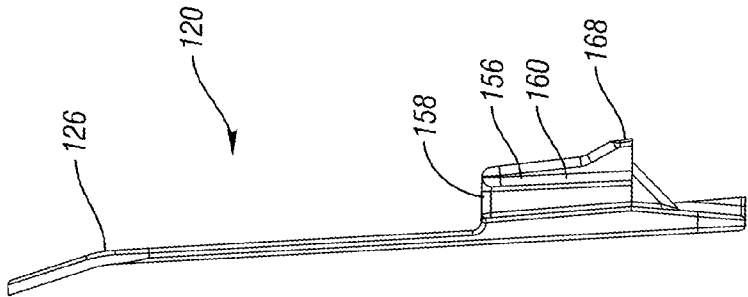

Fig. 19

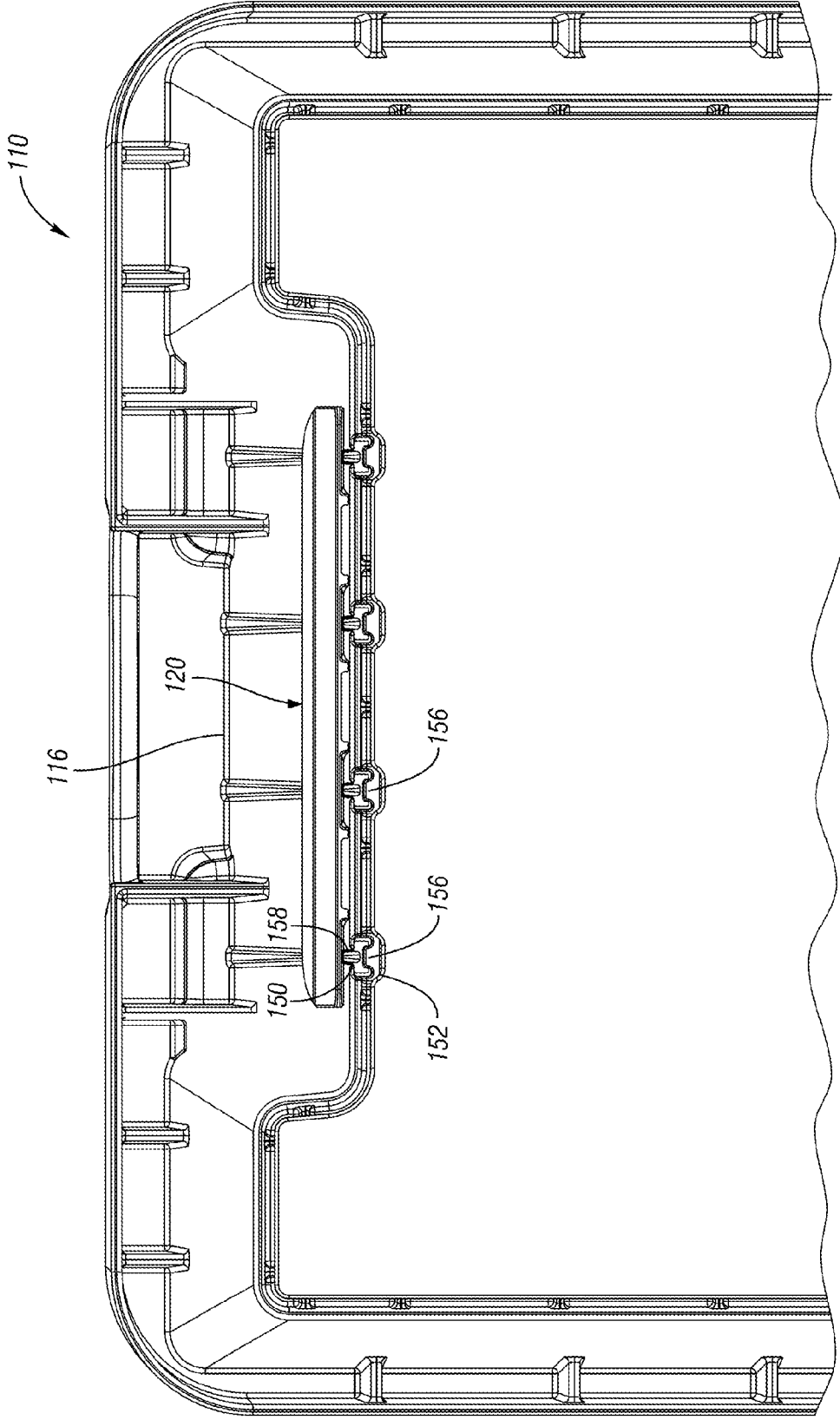

Fig. 20

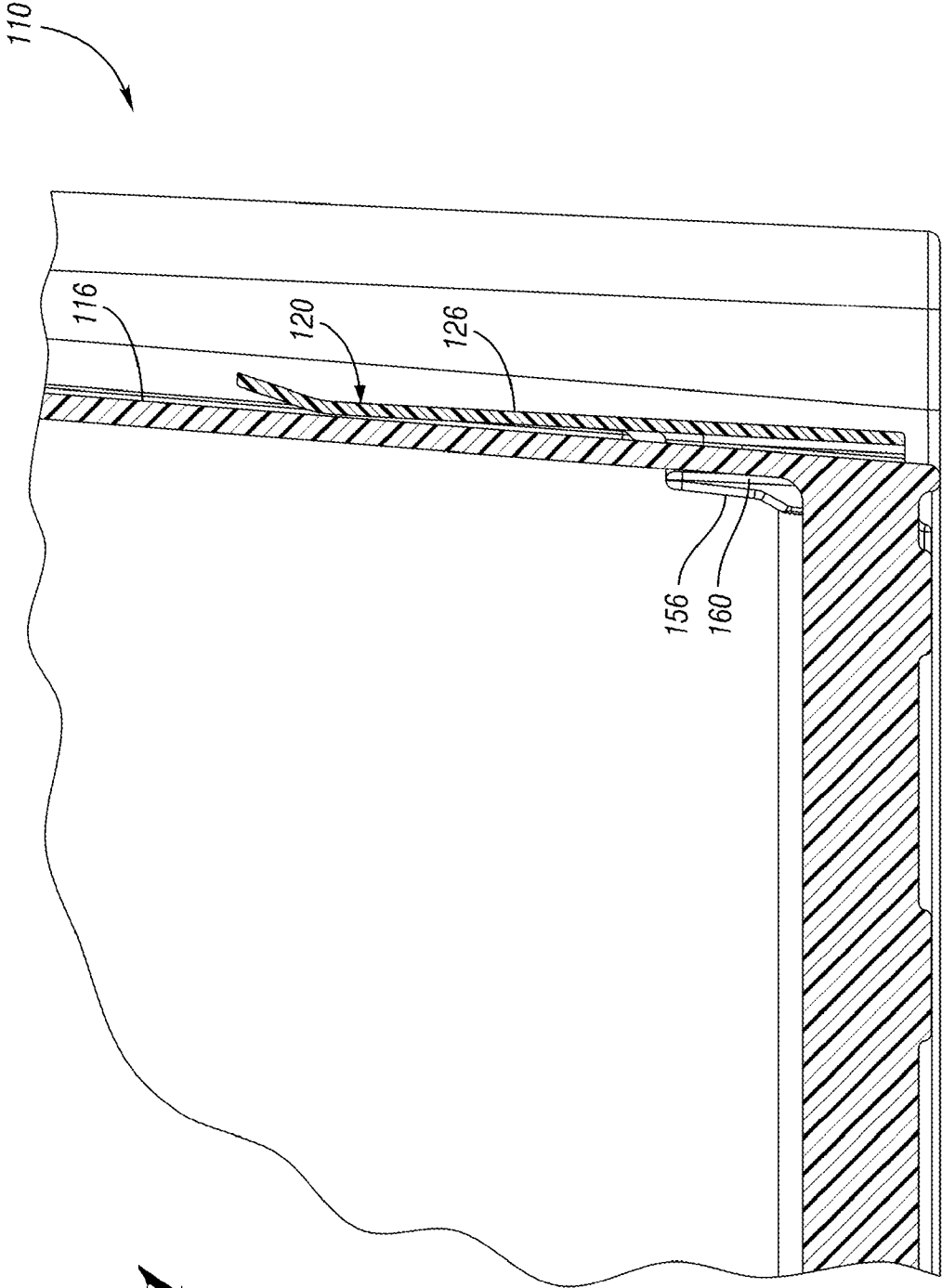

Fig. 21

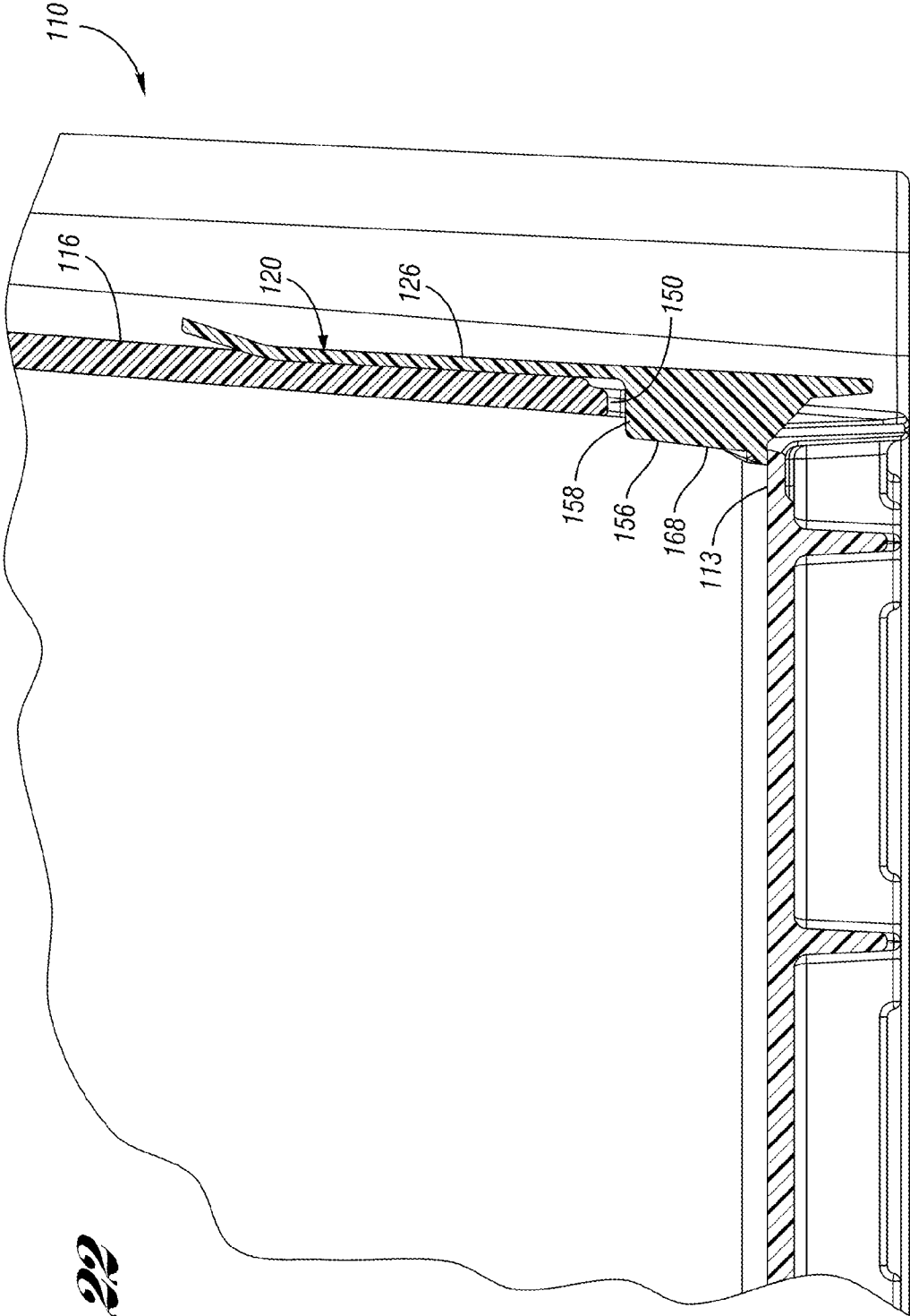

Fig. 22

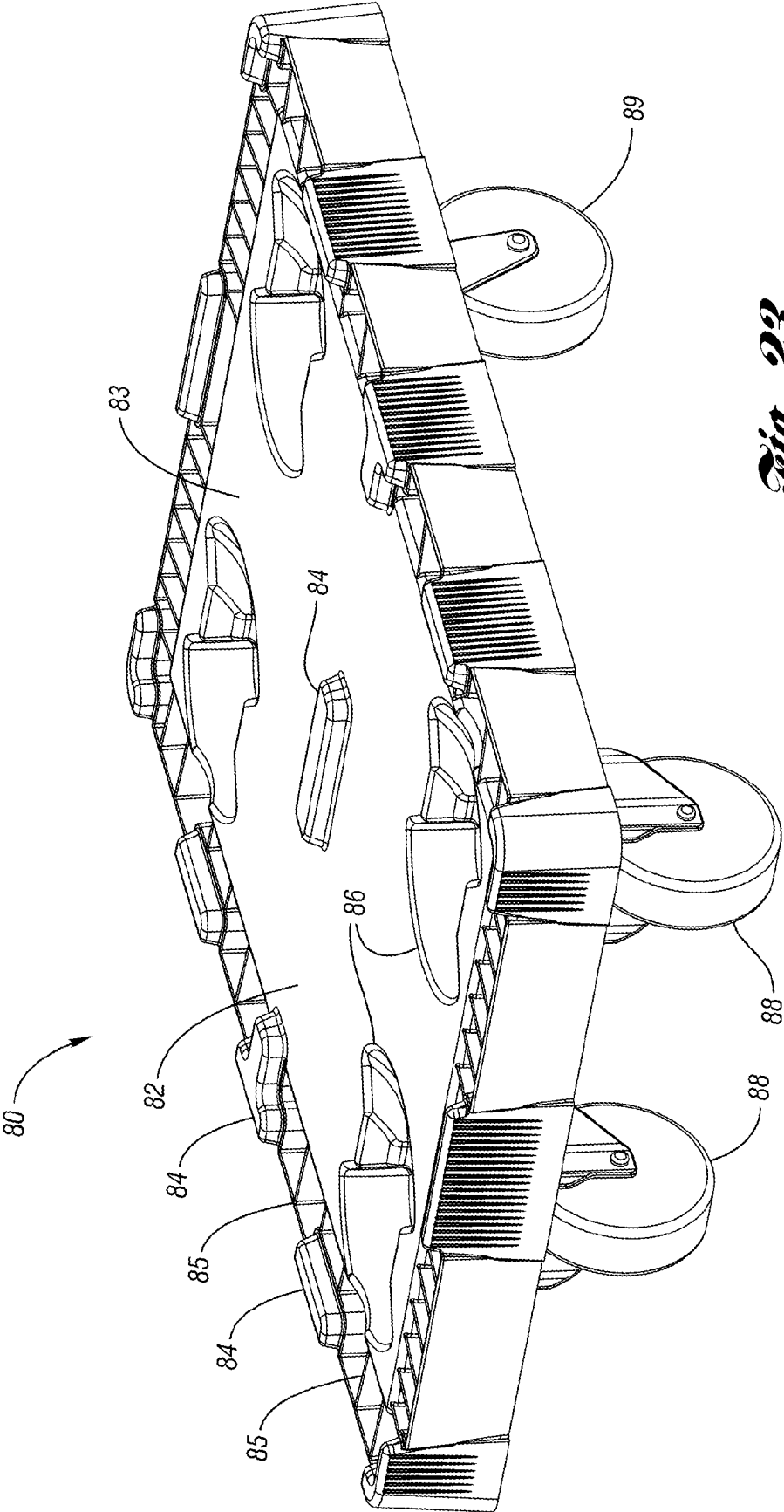

Fig. 23

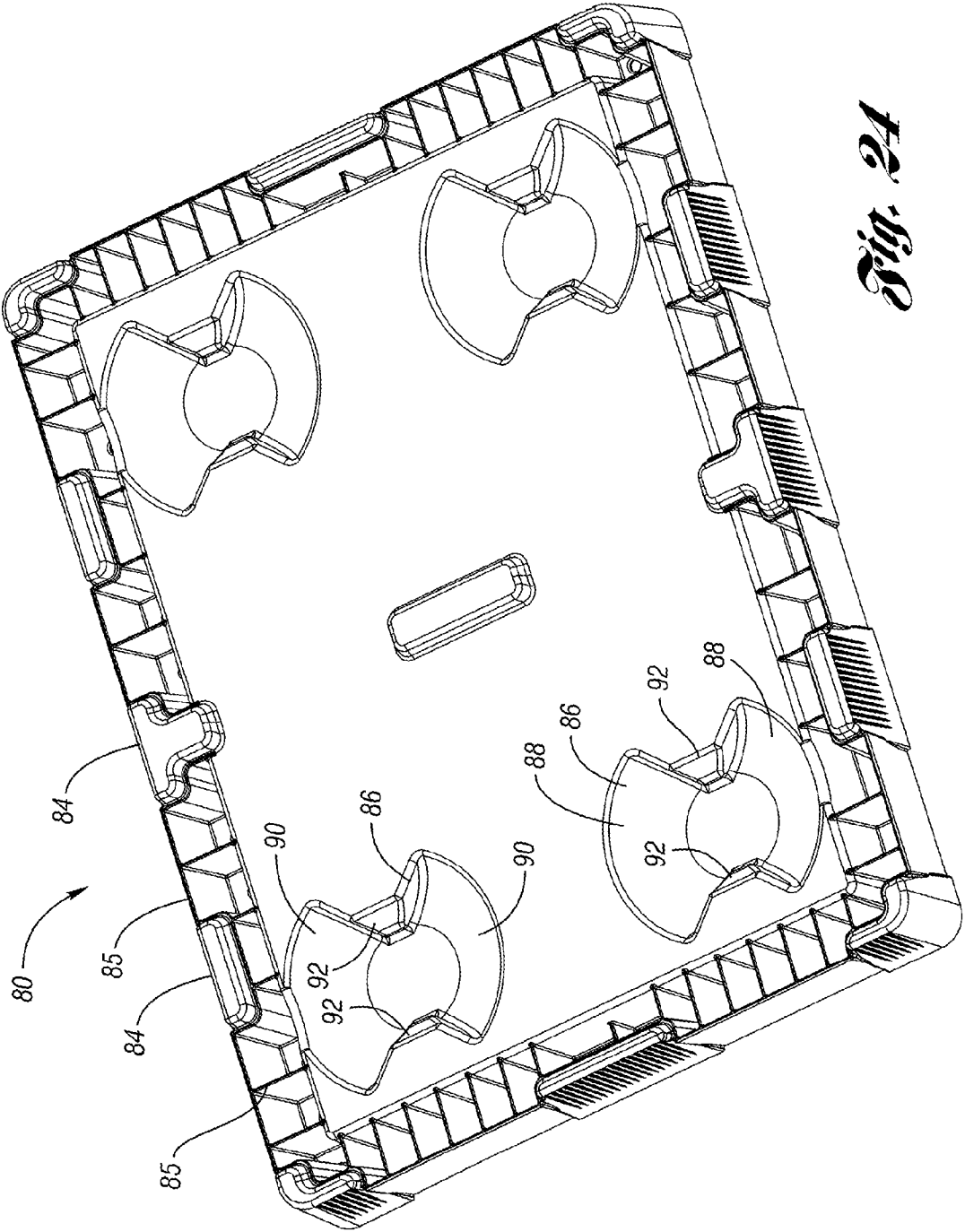

Fig. 2A

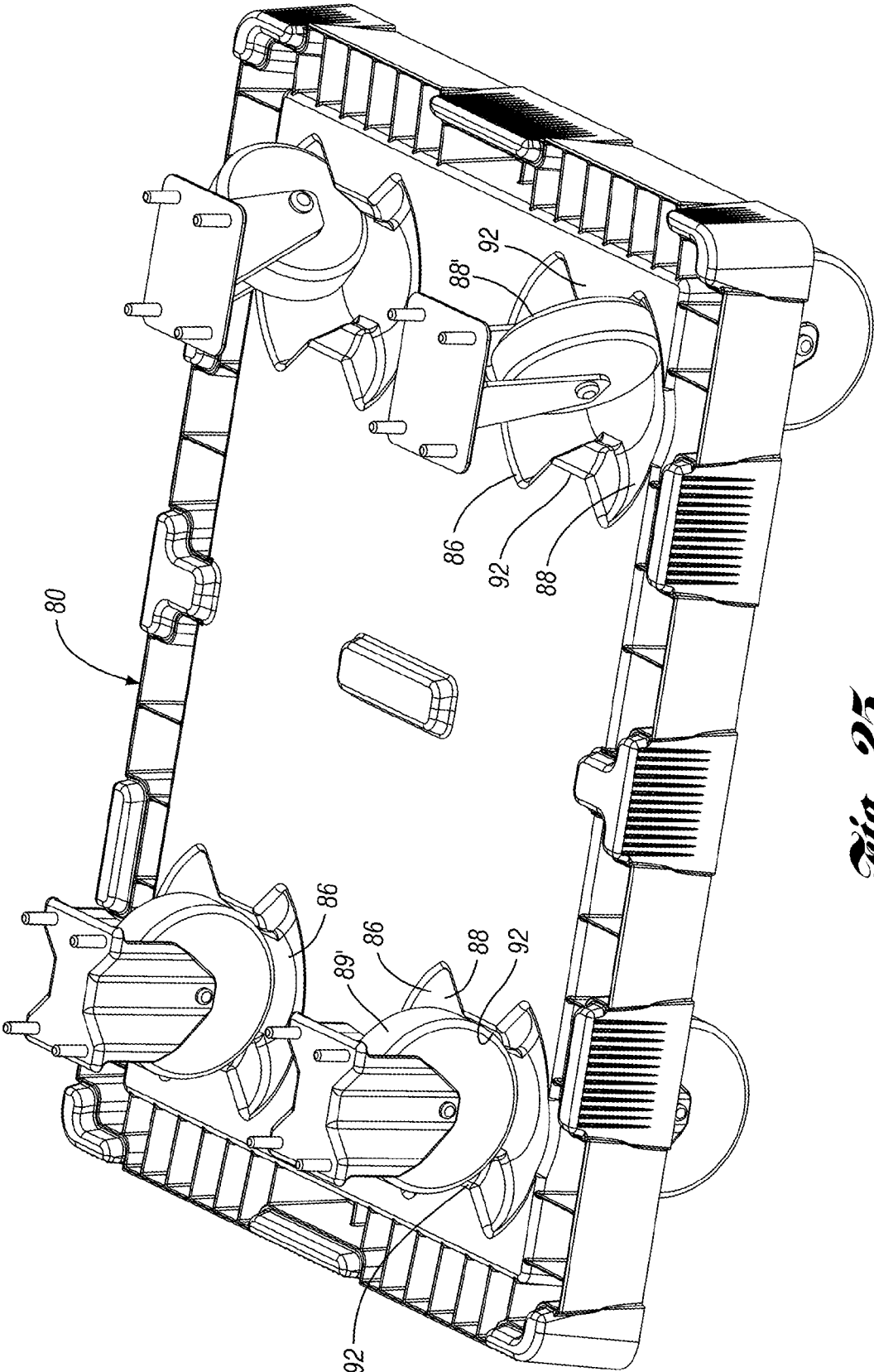

Fig. 25

TRAY AND DOLLY

BACKGROUND OF THE INVENTION

[0001] The present invention relates generally to a stackable and nestable tray.

[0002] There are known containers that are nestable when oriented alike and stackable when oriented 180 degrees relative to one another. Opposing walls of the containers are complementary, such that walls of a lower container will support a similar container stacked thereon in the 180 degree orientation.

[0003] One such container includes a holder for a card on the exterior of one end wall. The holder includes a small, flexible, clear plastic flap secured to the wall by rivets only at the lower end. The flap can be bent downward to insert (or remove) a card that identifies the contents of the container. Automated handling equipment bends the card holder flap to remove and replace the cards. Over time, the flap eventually breaks after repeated flexing.

[0004] Some containers include a complementary dolly for transporting a stack of loaded containers or empty containers. The dolly has two fixed casters and two casters that pivot about a vertical axis. The upper surface of the dolly includes recesses for receiving the casters of a similar dolly, such that they can be stacked when not in use. However, because two of the casters are rotatable, the user often has to rotate the rotatable casters to align them with the recesses on the dolly below.

SUMMARY OF THE INVENTION

[0005] The present invention provides a container having an improved card holder that is more durable and can withstand repeated use without fatigue. The card holder in one embodiment includes a flap for holding the card. The flap is connected to the container by a hinge. The hinge includes a hinge pin and a hinge receiver that permit the card holder to pivot, rather than bend. Flexible arms bias the sheet toward the closed position to retain the card.

[0006] A complementary dolly is also provided with recesses on its upper surface for automatically rotating the rotatable casters of a similar dolly stacked thereon to ensure proper alignment.

[0007] Although the card holder and the dolly are both disclosed in the context of a 180 degree stack/nest container, both the card holder and the dolly could be used with other types of containers and both could be used with or without one another.

BRIEF DESCRIPTION OF THE DRAWINGS

[0008] Other advantages of the present invention will be readily appreciated as the same becomes better understood by reference to the following detailed description when considered in connection with the accompanying drawings wherein:

[0009] FIG. 1 is a perspective view of a container according to a first embodiment of the present invention, with the card holder in the closed position.

[0010] FIG. 2 is an enlarged view the container of FIG. 1, with the card holder in the open position.

[0011] FIG. 3 is a perspective interior view of the card holder of FIG. 1.

[0012] FIG. 4 is a perspective exterior view of the card holder of FIG. 1.

[0013] FIG. 5 is a side view of the card holder of FIG. 1.

[0014] FIG. 6 is a perspective exterior view of the container of FIG. 1 without the card holder.

[0015] FIG. 7 is a perspective interior view of the container of FIG. 6.

[0016] FIG. 8 is a perspective exterior view of the container of FIG. 1, with the card holder in the closed position.

[0017] FIG. 9 is a section view through the end wall of the container of FIG. 1, with the card holder in the closed position.

[0018] FIG. 10 is a section view through the end wall of the container of FIG. 1, with the card holder in the closed position.

[0019] FIG. 11 is a section view through the end wall of the container of FIG. 1, with the card holder in the open position.

[0020] FIG. 12 is an upper perspective view of a container according to a second embodiment of the present invention.

[0021] FIG. 13 is a lower perspective view of the container of FIG. 12.

[0022] FIG. 14 is a lower perspective view of the container of FIG. 12, without the card holder.

[0023] FIG. 15 is an enlarged bottom view of the end wall of the container of FIG. 14.

[0024] FIG. 16 is a perspective interior view the container of FIG. 14.

[0025] FIG. 17 is a perspective view of the interior surface of the card holder of FIG. 12.

[0026] FIG. 18 is a bottom view of the card holder of FIG. 17.

[0027] FIG. 19 is a side view of the card holder of FIG. 17.

[0028] FIG. 20 is an enlarged bottom view of the end wall of the container of FIG. 12.

[0029] FIG. 21 is a section view through the center of the end wall of FIG. 20.

[0030] FIG. 22 is an alternate section view through the end wall of FIG. 20.

[0031] FIG. 23 is a perspective view of a dolly that can be used to carry a plurality of the containers of FIGS. 1-11 and/or FIGS. 12-22.

[0032] FIG. 24 is a top perspective view of the dolly of FIG. 23

[0033] FIG. 25 illustrates the alignment of casters from a dolly stacked on the dolly of FIG. 23.

[0034] FIG. 26 is a bottom perspective view of the dolly of FIG. 23.

DETAILED DESCRIPTION OF THE PREFERRED EMBODIMENT

[0035] FIGS. 1-11 illustrate a container 10 according to a first embodiment of the present invention. The container 10 includes a base 12, a pair of opposed side walls including side wall 14, and a pair of opposed end walls including end wall 16. In order to provide the 180 degree stacking and nesting functionality, the side walls and end walls include alternating inward and outward offset portions 18. The offset portions 18 on the opposed side walls and opposed end walls are arranged such that a like container will nest in the container 10 if rotationally aligned and will stack on the container if rotated 180 degrees relative to the container 10.

[0036] The container 10 includes a card holder 20 connected by a hinge 22 at its lower end to the end wall 16. In FIG. 1, the card holder 20 is shown in the closed position with a card 50 retained between the card holder 20 and the end wall 16. The card 50 includes indicia 52 of the contents of the container 10. The indicia 52 may be text and/or computer

readable indicia, such as a barcode. The card holder 20 is clear plastic so that the indicia 52 is readable through the card holder 20. As shown in FIG. 2, the card holder 20 can be pivoted about the hinge 22 to an open position so that a card can be inserted or removed from behind the card holder 20.

[0037] The card holder 20 is shown in FIGS. 3-5. The card holder 20 includes a flap 26 connected to a hinge pin 28 by a plurality of tabs 30. The tabs 30 extend at an obtuse angle from the flap portion 26 and are spaced apart by openings 34 and arches 32.

[0038] FIGS. 6 and 7 show the container 10 without the card holder 20. Cantilevered arms 40 form hinge receivers between recesses 42. Each of the recesses 42 is defined by a corresponding arch 32 protruding into the interior of the container 10. Each of the arches 32 includes a center opening 44.

[0039] As shown in FIG. 8, the card holder 20 is attached to the container 10 by snapping the hinge pin 28 under the hinge receivers formed by the arms 40 on the container 10 (FIG. 9). The arches 32 of the card holder 20 are received in the openings 44 of the recesses 42 on the container 10 (FIG. 10).

[0040] As shown in FIG. 11, in use the card holder 20 is pulled to the open position (shown) so that a card 50 with information printed or stored thereon can be inserted behind the flap 26. When the card holder 20 is pivoted outward, the arches 32 of the card holder 20 are compressed, such that the arches 32 bias the flap 26 back toward the closed position when the flap 26 is released. The card 50 can then be read through the flap 26. Note that the flap 26 itself need not be flexible.

[0041] The card holder 20 is more durable than the previous card holder, even after being opened and closed many times. Additionally, if the card holder 20 does break, it is easily replaced, unlike the previous card holder.

[0042] A container 110 and a card holder 120 according to a second embodiment of the present invention is shown in FIGS. 12-22. Referring to FIG. 12, the container 110 includes side walls 114 and end walls 116, 117. The container 110 includes offset portions 118 such that the container 110 includes the 180 degree stack/nest feature as does the previous embodiment. The card holder 120 is clear plastic so that the indicia 52 on the card 50 is readable through the card holder 120.

[0043] As shown in FIG. 13, the end wall 116 includes a plurality of vertical slots 150 to which the card holder 120 is attached. The container 110 includes a base cover 112 providing a smooth lowermost surface.

[0044] FIGS. 14-16 show the container 110 without the card holder 120 and without the base cover 112. The container 110 includes base wall 113 having a plurality of cross ribs 115 to which the base cover 112 (FIG. 13) can be secured. The vertical slots 150 in the end wall 116 open downward and are contiguous with openings 152 through the base wall 113.

[0045] FIGS. 17-19 show the card holder 120. The card holder 120 is molded of a clear plastic and includes a flap 126 integrally molded with connectors 156. Each connector 156 includes a rib 158 connecting a flange 156 to the flap 126. Each flange 156 includes an enlarged base 168. The flap 126 includes a portion of increased thickness 170 around each connector 156 to increase strength and to make the flap 126 fit tightly against the tub end wall surface.

[0046] Referring to FIGS. 20-22, the card holder 120 is connected to the container 110 by sliding the connectors 156 into the openings 152. The ribs 158 slide into the vertical slots

150 until the enlarged base 168 of each connector 156 snaps past the base wall 113 (FIG. 22).

[0047] In use, the card holder 120 is pulled outward away from the end wall 116 so that a card 50 (FIG. 12) can be inserted.

[0048] FIG. 23 is a perspective view of a dolly 80 that can be used to carry a plurality of the containers 10, 110 of FIGS. 1-22. The dolly 80 includes a deck 82 having a generally continuous center upper wall 83 and plurality of protruding locators 84 located around the periphery of the deck 82 and in the center of the deck 82. The locators 84 around the periphery are spaced apart by open, ribbed areas 85. The upper surface of the deck 82 further includes a plurality of recesses 86 each aligned with casters 88, 89 on the lower side of the deck 82, such that the casters 88, 89 of a similar dolly stacked thereon would be received in the recesses 86 as will be explained below. The casters 88 each freely rotate about an axis perpendicular to the deck 82. The casters 89 are fixed in a fixed orientation relative to the axis perpendicular to the deck 82. The dolly 80 could alternatively have four rotatable casters 88. As shown in FIG. 20, the recesses 86 each include a pair of curved or spherical segments 90 separated by tapered dividers 92.

[0049] As shown in FIG. 25, when a similar dolly (only the casters 88', 89' are shown) is stacked on the dolly 80, the rotational positions of the rotatable casters 88 will be realigned by the tapered dividers 92 into the recesses 86. The fixed casters 89' on the dolly will be received in the recesses 86 between the tapered dividers 92. Thus the dollies can be stacked without regard for orientation of the casters 88, 89, which direction the dolly is oriented and whether the dolly has four rotatable casters 88' or two.

[0050] FIG. 26 is a bottom perspective view of the dolly 80. As shown, the bottom of each of the locators 84 is open. However, the open, ribbed areas 85 (FIG. 24) are open so that most of the peripheral portions 93 of the bottom of the deck 82 can be substantially closed (other than small drainage holes). The closed peripheral portions 93 of the bottom of the deck 82 facilitates handling by automated handling equipment. The closed peripheral portions 93 correspond to the open, ribbed areas 85 (FIG. 23) on the upper side of the deck 82. The closed locators 84 on the top of the deck 82 (FIG. 23) correspond to the open areas. The remainder of the underside of the deck 82 is defined by ribs 95 extending downwardly from the upper wall 83 (FIG. 23) of the deck 82.

[0051] Although a preferred embodiment of this invention has been disclosed, a worker of ordinary skill in this art would recognize that certain modifications would come within the scope of this invention. For that reason, the following claims should be studied to determine the true scope and content of this invention.

What is claimed is:

1. A container comprising:
a floor;
a first wall extending upward from the floor; and
a card holder snap-fit to the first wall and pivotable relative to the first wall, the card holder including a flap portion.
2. The container of claim 1 wherein the flap portion is clear.
3. The container of claim 1 wherein the card holder is a clear plastic.
4. The container of claim 1 wherein a similar container can be nested therein when oriented similarly and can be stacked thereon when oriented 180 degrees relative thereto.

5. The container of claim 1 wherein the card holder is pivotably secured to the first wall by a hinge, the hinge including a hinge pin snap-fit into a hinge receiver.

6. The container of claim 5 wherein the hinge pin is integrally molded with the card holder.

7. The container of claim 6 wherein the hinge receiver is formed in the first wall.

8. The container of claim 7 wherein the first wall includes at least one arm forming the hinge receiver.

9. The container of claim 1 wherein the card holder includes at least one integrally molded connector received in a slot in the first wall.

10. The container of claim 9 wherein the slot in the first wall is a vertical slot opening downward.

11. The container of claim 10 wherein the connector snap-fits past the floor to connect the card holder to the container.

12. The container of claim 1 further including a card with indicia between the card holder and the first wall.

13. The container of claim 1 further including second, third and fourth walls extending upward from the floor to define an interior compartment of the container with the first wall.

14. A dolly comprising:
a deck having a plurality of recesses formed in an upper surface thereof, the recesses each including two curved portions partially separated by tapered dividers; and
a plurality of casters extending downward from the deck, each aligned with one of the plurality of recesses.

15. The dolly of claim 14 wherein the casters are rotatable about an axis perpendicular to the deck.

16. The dolly of claim 14 wherein the plurality of casters include two casters rotatable about an axis perpendicular to the deck and two fixed casters.

17. The dolly of claim 14 further including a plurality of locators protruding upwardly from a periphery of the deck.

18. The dolly of claim 14 further including a substantially closed peripheral portion about the periphery of the underside of the deck.

19. The dolly of claim 18 wherein the deck includes an upper panel down from which a plurality of ribs extend, the peripheral portion corresponding to an upper periphery extending around the periphery of the upper panel, the upper periphery being primarily open, with ribs extending there-through.

20. The dolly of claim 19 further including a plurality of locators protruding upward from the upper periphery of the deck, the locators opening downwardly.

21. A container comprising:
a floor;
a plurality of walls extending upward from the floor to define an interior compartment, the plurality of walls including a first wall, the first wall including an integrally molded hinge receiver; and
a card holder including a flap portion and an integrally molded hinge pin snap-fit into the hinge receiver.

22. The container of claim 21 wherein the flap portion is clear.

23. The container of claim 21 further including a card having indicia thereon, the card retained between the flap portion and the first wall, the indicia readable through the flap portion.

24. The container of claim 21 wherein the hinge pin is connected to the flap portion by a flexible arch, the arch biasing the flap portion toward the first wall.

* * * * *