

L. S. STARRETT,

VICE.

APPLICATION FILED JUNE 29, 1910.

1,012,226.

Patented Dec. 19, 1911.

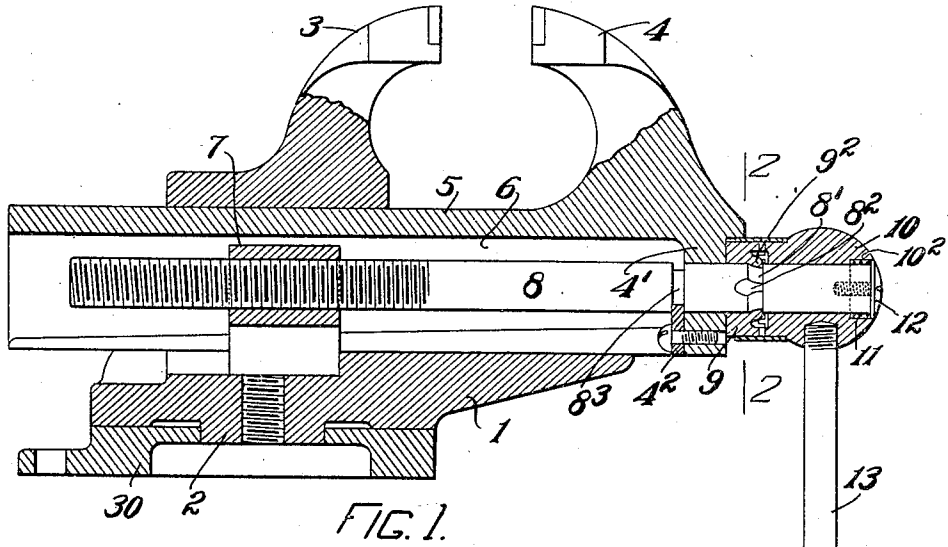

FIG. 1.

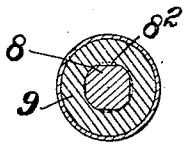

FIG. 2.

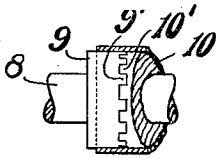

FIG. 3.

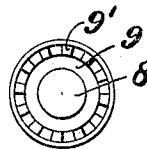

FIG. 4.

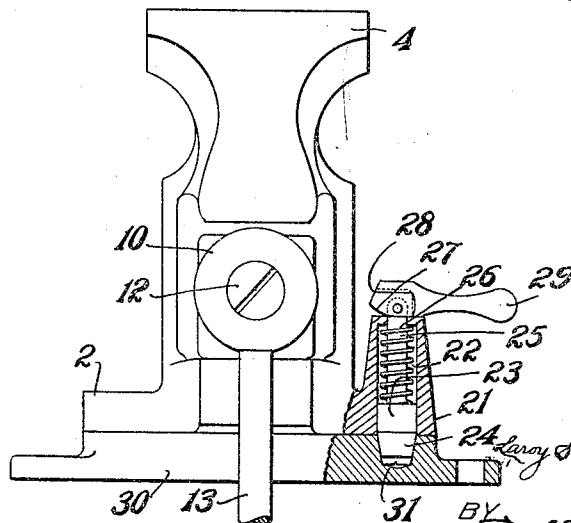

FIG. 5.

WITNESSES  
L. Goodman  
R. B. Ellms.

INVENTOR  
L. S. Starrett.

BY  
O. S. Sperry  
ATTY

# UNITED STATES PATENT OFFICE.

LAROCY S. STARRETT, OF ATHOL, MASSACHUSETTS, ASSIGNOR TO L. S. STARRETT COMPANY, OF ATHOL, MASSACHUSETTS, A CORPORATION OF MASSACHUSETTS.

## WISE.

1,012,226.

Specification of Letters Patent.

Patented Dec. 19, 1911.

Application filed June 29, 1910. Serial No. 569,436.

*To all whom it may concern:*

Be it known that I, LAROCY S. STARRETT, a citizen of the United States, residing at Athol, county of Worcester, Commonwealth of Massachusetts, have invented certain new and useful Improvements in Vises, of which the following is a specification.

This invention relates to vises, and particularly to the adjustment and positioning of the vise jaws.

The desired adjustment and positioning of vise jaws is usually a double one, first the movement of the jaws with relation to each other to clamp the work and second the setting of the jaws relative to the support to give proper access and convenience in position, at any angle with the bench.

In most forms of vises, and especially in such vises as employ a screw to secure relative movement of the clamping jaws, it has been customary to provide a bar for the rotation of the screw shaft. This bar, in order to be accessible and in order to have sufficient operating room, must be located on the outside of the vise where it will clear the bench and be convenient to the hand of the workman. Its very position of convenience, however, has proved a matter of inconvenience under many circumstances, inasmuch as on many jobs it is necessary for the workman to get close to the vise, in a position which has been rendered impossible, or at least awkward or uncomfortable by the protruded ends of the operating bar. This was early recognized and an effort was made to overcome the difficulty by making the operating bar slidable through the head at the end of the screw shaft, so that after the vise had been set up the bar could be slid down through the head to hang below the level of the vise, and thus be out of the way of the user. Such a construction, although of such assistance that it came into practically universal use, had many difficulties. One of these was that unless the jaws happened to meet at the particular phase of the rotation of the head, which would leave the bar in a vertical position, the lower end of the bar projected to one side or another, so as to be in the way of the body of a workman. As the operating bar only came in vertical po-

sition twice in each revolution it usually did project more or less on the side and was, therefore, usually in the way. Another difficulty with the sliding bar was that it frequently dropped or slid through the head at unexpected times and, as it was usually supplied at either end with a ball stop of considerable weight, there was a frequent opportunity for pinching or bruising the hands of the operative if they happened to be near at the time of such a fall.

In view of all these difficulties, it is the object of the present invention to provide an operating device which shall be capable of satisfactorily performing the usual functions of the ordinary operating bar and at the same time be capable of a return to a position in which it will be out of the way. This is accomplished by the operating head being disengageable from the operating shaft so as to permit it to be dropped into the position desired at whatever phase of rotation the shaft be in when the jaws are clamped upon the work. The positioning of the jaws I accomplish by means which make their adjustment and readjustment a matter of ease and facility.

In the drawings which form a part of the specification, is shown, as illustrative of the invention, an ordinary vise equipped with a form of the invention which is found well adapted to practical uses.

Throughout specification and drawings like reference numerals are employed to indicate corresponding parts and in the drawings:—Figure 1 is a central vertical section of a vise equipped with the invention, Fig. 2, a sectional view of the shaft, clutch and collar on the line 2—2, Fig. 1, Fig. 3, a side view of the clutch members with the sleeve broken away, Fig. 4, a face view of one of the clutch members, and Fig. 5 is an end view of my vise with a part broken away to show the locking pin.

The vise illustrated in the drawing consists of a usual base 1 suitably connected by a pivot 2 to a plate 30 which may be bolted to the bench in the usual manner, and having formed on its upper portion a jaw 3. The oppositely faced jaw 4 is provided with a guiding shank 5 which passes through an

opening in the base 1 below the jaw 3. The guide piece 5 is hollowed at 6 to pass a threaded stud 7 on the base plate 1. The shaft 8 has a threaded engagement with the projection 7 and passes through the lower end 4' of the jaw 4. The shaft 8 is held longitudinally by a plate 4<sup>2</sup> which engages a groove 8<sup>3</sup> on the shaft 8. Just outside of the lower end 4' a shaft 8 is grooved and notched at 8', 8<sup>2</sup>, respectively, and into this groove and the recesses is forced the central projecting hub 9<sup>2</sup> of a clutch member 9. The clutch member has square engaging teeth 9' for engagement with oppositely faced teeth 10' formed on the head 10, through which the screw shaft 8 passes with a sliding fit. There are a plurality of teeth 9' and 10' on each quadrant of the clutch so that the clutch members 9 and 10 may be engaged in a plurality of different positions for each quarter turn of the shaft 8. At its outer end the head 10 is enlarged around the bar which receives the screw shaft at 10<sup>2</sup> and within this cavity about the end of the screw shaft 8 is located a coiled spring 11 which is held in place by a screw 12 having a large flat head.

13 is the operating bar screwed into the head 10 and having at its opposite end any convenient ball or knob 13<sup>3</sup>. The handle 13 is, therefore, fixed upon one side of the head 10 and by means of the plurality of teeth on each quadrant of the clutch this handle may be set in a great variety of positions about the shaft 8. This is of great advantage not only in securing a position of maximum leverage without the necessity of a change of position of the workman but also makes it possible to set the handle 13 where it may be used as a rest or support for the hand or for a tool or to set it in a position where it will be wholly out of the way of the hand or tool of the workman.

On the base 2 is cast a stub 21 which is bored at 22 and within the bore is located a plunger 23 having a tapered end 24. Above the plunger 23 is a stem 25 around which is a coiled spring 26 bearing against the shoulder of the plunger 23 at one end and against the bottom of the bore 22 at its opposite end. On the end of the plunger 25 is pivoted a handle 29 which has a rounded cam shaped end 27 and a flattened portion 28. The plate 30 is provided with a plurality of sockets 31 arranged concentrically about the pivot 2 and adapted to receive the tapered end 24 of the plug 23 when the vise is swung.

The operation of the device is as follows: In the position shown in Fig. 1, with the clutch members in engagement, the operating bar 13 may be turned to rotate the screw shaft 8 in either direction to rotate the jaws toward or from each other. When the jaws have been screwed up on a piece of work, if

the bar 13 is left in any other than a vertical position the head 10 is pulled out slightly against the action of the spring 11, thus disengaging the clutch teeth 9', 9<sup>2</sup> and 10'. As soon as the clutch teeth are disengaged the operating bar 13 may be dropped into a vertical position in which it will remain. This not only removes the bar 13 from its inconvenient position, but disengages it as an operating means, so that there is no danger of an accidental loosening of the vise by any accidental movement of the operating bar. When it is desired to again turn the screw to loosen the jaws the bar 13 may be swung into any position of advantage, according to the attitude of the workman, and upon the engagement of the clutches the jaws may be again moved. It will thus be seen that this invention not only affords relief from the many difficulties which have heretofore beset the users of vises, but it also offers many increased advantages in facility and ease of operation. In positioning the jaws relative to the bench of the workman, the handle 29 may be raised and through the action of the rounded cam 27 the plunger 23 will be lifted, disengaging the tapered end 24 from the socket 31 with which it has been in engagement. As the end of the handle 29 passes off of the rounded cam 27 it positions itself on the portion 28 which is beveled back in the opposite direction so that the handle 29 is locked under the action of the spring in lifted position. With the handle thus raised the vise may be swung around its pivot 2 into any position desired.

Various modifications may, of course, be made in the embodiment shown, all without departing from the spirit of the invention, if within the limits of the appended claims.

What I therefore claim and desire to secure by Letters Patent is:—

1. In a vise, a fixed jaw, means for supporting said jaw, a second jaw movable relatively thereto, a threaded shaft for operating said second jaw and held against longitudinal movement thereon, a threaded block on said support and receiving said threaded shaft, a clutch hub on said shaft, a clutch head loosely mounted on the end of said shaft, the inner end of said head being of the same diameter as said hub, a sleeve on the inner end of said head and inclosing said hub, the outer end of said head having a recess about the end of the shaft, a spiral spring in said recess and a closing plate for said recess and engaging the outer end of said spring and attached to the end of said shaft.

2. In combination with the operative screw of a vise, a clutch hub fixed on the shaft thereof and adjacent to one end, a head upon the end of the shaft, an oppositely faced clutch on said head of substan-

tially the diameter of said hub, a sleeve on  
said head, surrounding said clutch and in-  
closing said hub, the outer end of said head  
having a recess about the end of the shaft, a  
5 spring in said recess and surrounding the  
recess, and bearing upon said spring and an  
operating bar fixed in said head.

In testimony whereof, I affix my signature  
in presence of two witnesses.

LAROY S. STARRETT.

Witnesses:

FRANK E. WING,  
ERNEST W. TAYLOR.