



## INTERNATIONAL APPLICATION PUBLISHED UNDER THE PATENT COOPERATION TREATY (PCT)

|   |  |  |
|---|--|--|
| <b>(51) International Patent Classification <sup>6</sup> :</b><br><b>B01L 3/14, G01N 35/00, C07K 1/04,</b><br><b>G01N 33/48, 33/58, 33/543, B01J 19/00</b>  | <b>A1</b>  | <b>(11) International Publication Number:      WO 96/36436</b><br><br><b>(43) International Publication Date:    21 November 1996 (21.11.96)</b> |
| <b>(21) International Application Number:</b> PCT/US96/06145<br><br><b>(22) International Filing Date:</b> 25 April 1996 (25.04.96)<br><br><b>(30) Priority Data:</b><br>428,662            25 April 1995 (25.04.95)      US<br>473,660            7 June 1995 (07.06.95)        US<br>480,147            7 June 1995 (07.06.95)        US<br>480,196            7 June 1995 (07.06.95)        US<br>484,486            7 June 1995 (07.06.95)        US<br>484,504            7 June 1995 (07.06.95)        US<br>08/538,387        3 October 1995 (03.10.95)      US<br>08/567,746        5 December 1995 (05.12.95)    US<br>08/639,813        2 April 1996 (02.04.96)        US<br><br><b>(71) Applicant (for all designated States except US):</b> IRORI<br>[US/US]; 11025 North Torrey Pines Road, #100, La Jolla,<br>CA 92037 (US).  | <b>(71)(72) Applicants and Inventors:</b> NOVA, Michael, P. [US/US];<br>16428 La Gracia, Rancho Santa Fe, CA 92067 (US).<br>SENYEI, Andrew, E. [US/US]; 1740 El Camino del Teatro,<br>La Jolla, CA 92037 (US). PARANDOOSH, Zahra [US/US];<br>4626 Exbury Court, San Diego, CA 92130 (US). DAVID,<br>Gary, S. [US/US]; 9477 Poole Street, La Jolla, CA 92037-<br>1143 (US). XIAO, Xiao-Yi [US/US]; 4951 Riding Ridge<br>Road, San Diego, CA 92130 (US).<br><br><b>(74) Agent:</b> SEIDMAN, Stephanie; Brown, Martin, Haller &<br>McClain, 1660 Union Street, San Diego, CA 92101-2926<br>(US).<br><br><b>(81) Designated States:</b> AL, AM, AT, AU, AZ, BB, BG, BR, BY,<br>CA, CH, CN, CZ, DE, DK, EE, ES, FI, GB, GE, HU, IS,<br>JP, KE, KG, KP, KR, KZ, LK, LR, LS, LT, LU, LV, MD,<br>MG, MK, MN, MW, MX, NO, NZ, PL, PT, RO, RU, SD,<br>SE, SG, SI, SK, TJ, TM, TR, TT, UA, UG, US, UZ, VN,<br>ARIPO patent (KE, LS, MW, SD, SZ, UG), Eurasian patent<br>(AM, AZ, BY, KG, KZ, MD, RU, TJ, TM), European patent<br>(AT, BE, CH, DE, DK, ES, FI, FR, GB, GR, IE, IT, LU,<br>MC, NL, PT, SE), OAPI patent (BF, BJ, CF, CG, CI, CM,<br>GA, GN, ML, MR, NE, SN, TD, TG).<br><br><b>Published</b><br><i>With international search report.</i><br><i>Before the expiration of the time limit for amending the</i><br><i>claims and to be republished in the event of the receipt of</i><br><i>amendments.</i> |  |
| <b>(54) Title:</b> REMOTELY PROGRAMMABLE MATRICES WITH MEMORIES AND USES THEREOF  |  |  |
| <b>(57) Abstract</b><br><br><p>Combinations, called matrices with memories, of matrix materials with remotely addressable or remotely programmable recording devices that contain at least one data storage unit are provided. The matrix materials are those that are used in as supports in solid phase chemical and biochemical syntheses, immunoassays and hybridization reactions. The matrix materials may additionally include fluophors or other luminescent moieties to produce luminescing matrices with memories. The data storage units are non-volatile antifuse memories or volatile memories, such as EEPROMS, DRAMS or flash memory. By virtue of this combination, molecules and biological particles, such as phage and viral particles and cells, that are in proximity or in physical contact with the matrix combination can be labeled by programming the memory with identifying information and can be identified by retrieving the stored information. Combinations of matrix materials, memories, and linked molecules and biological materials are also provided. The combinations have a multiplicity of applications, including combinatorial chemistry, isolation and purification of target macromolecules, capture and detection of macromolecules for analytical purposes, selective removal of contaminants, enzymatic catalysis, cell sorting, drug delivery, chemical modification and other uses. Methods for electronically tagging molecules, biological particles and matrix support materials, immunoassays, receptor binding assays, scintillation proximity assays, non-radioactive proximity assays, and other methods are also provided.</p> |  |  |

*FOR THE PURPOSES OF INFORMATION ONLY*

Codes used to identify States party to the PCT on the front pages of pamphlets publishing international applications under the PCT.

|    |                          |    |  |    |                          |
|----|--------------------------|----|--|----|--------------------------|
| AM | Armenia                  | GB | United Kingdom                           | MW | Malawi                   |
| AT | Austria                  | GE | Georgia                                  | MX | Mexico                   |
| AU | Australia                | GN | Guinea                                   | NE | Niger                    |
| BB | Barbados                 | GR | Greece                                   | NL | Netherlands              |
| BE | Belgium                  | HU | Hungary                                  | NO | Norway                   |
| BF | Burkina Faso             | IE | Ireland                                  | NZ | New Zealand              |
| BG | Bulgaria                 | IT | Italy                                    | PL | Poland                   |
| BJ | Benin                    | JP | Japan                                    | PT | Portugal                 |
| BR | Brazil                   | KE | Kenya                                    | RO | Romania                  |
| BY | Belarus                  | KG | Kyrgystan                                | RU | Russian Federation       |
| CA | Canada                   | KP | Democratic People's Republic<br>of Korea | SD | Sudan                    |
| CF | Central African Republic | KR | Republic of Korea                        | SE | Sweden                   |
| CG | Congo                    | KZ | Kazakhstan                               | SG | Singapore                |
| CH | Switzerland              | LI | Liechtenstein                            | SI | Slovenia                 |
| CI | Côte d'Ivoire            | LK | Sri Lanka                                | SK | Slovakia                 |
| CM | Cameroon                 | LR | Liberia                                  | SN | Senegal                  |
| CN | China                    | LT | Lithuania                                | SZ | Swaziland                |
| CS | Czechoslovakia           | LU | Luxembourg                               | TD | Chad                     |
| CZ | Czech Republic           | LV | Latvia                                   | TG | Togo                     |
| DE | Germany                  | MC | Monaco                                   | TJ | Tajikistan               |
| DK | Denmark                  | MD | Republic of Moldova                      | TT | Trinidad and Tobago      |
| EE | Estonia                  | MG | Madagascar                               | UA | Ukraine                  |
| ES | Spain                    | ML | Mali                                     | UG | Uganda                   |
| FI | Finland                  | MN | Mongolia                                 | US | United States of America |
| FR | France                   | MR | Mauritania                               | UZ | Uzbekistan               |
| GA | Gabon                    |    |  | VN | Viet Nam                 |

-1-

**REMOTELY PROGRAMMABLE MATRICES WITH MEMORIES  
AND USES THEREOF**

**RELATED APPLICATIONS**

For U.S. national purposes, this application is a continuation-in-part of U.S. application Serial No. 08/DKT302B, filed April 2, 1996, entitled  
5 REMOTELY PROGRAMMABLE MATRICES WITH MEMORIES AND USES  
THEREOF ", by Michael P. Nova, Andrew E. Senyei, Zahra Parandoosh  
and Gary S. David, which application is a continuation-in-part of U.S.  
application Serial No. 08/567,746, filed December 5, 1995, entitled  
10 REMOTELY PROGRAMMABLE MATRICES WITH MEMORIES AND USES  
THEREOF ", by Michael P. Nova, Andrew E. Senyei, Zahra Parandoosh  
and Gary S. David, which application is a continuation-in-part of U.S.  
application Serial No. 08/538,387, filed October 3, 1995, entitled  
"REMOTELY PROGRAMMABLE MATRICES WITH MEMORIES", Michael  
P. Nova, Andrew E. Senyei, and Gary S. David , which in turn is a  
continuation-in-part of U.S. application Serial Nos. 08/480,147,  
15 08/484,486, 08/484,504, 08/480,196 and 08/473,660, each filed June  
7, 1995, and each entitled, "REMOTELY PROGRAMMABLE MATRICES  
WITH MEMORIES".

This application is also a continuation-in-part of U.S. application  
Serial No. 08/538,387, and a continuation-in-part of each of U.S.  
20 application Serial Nos. 08/480,147, 08/484,486, 08/484,504,  
08/480,196, 08/473,660, and 08/428,662, filed April 25, 1995, by  
Michael P. Nova and Andrew E. Senyei, entitled, "REMOTELY  
PROGRAMMABLE MATRICES WITH MEMORIES". Each of U.S.  
application Serial Nos. 08/dkt302, 08/567,746, 08/538,387,  
25 08/480,147, 08/484,486, 08/484,504, 08/480,196 and 08/473,660 is  
a continuation-in-part of U.S. application Serial No. 08/428,662.

-2-

The subject matter of each of U.S. application Serial Nos. 08/DKT302B, 08/567,746, 08/538,387, 08/480,147, 08/484,486, 08/484,504, 08/480,196, 08/473,660 and 08/428,662 is incorporated herein by reference in its entirety. The subject matter of each of U.S. application Serial Nos. 08/379,923 and 08/322,644 also is incorporated herein its entirety.

#### **FIELD OF THE INVENTION**

The present invention relates to the application of data storage technology to molecular tracking and identification and to biological, chemical, immunological and biochemical assays.

#### **BACKGROUND OF THE INVENTION**

Drug discovery relies on the ability to identify compounds that interact with a selected target, such as cells, an antibody, receptor, enzyme, transcription factor or the like. Traditional drug discovery relied on collections or "libraries" obtained from proprietary databases of compounds accumulated over many years, natural products, fermentation broths, and rational drug design. Recent advances in molecular biology, chemistry and automation have resulted in the development of rapid, High throughput screening (HTS) protocols to screen these collection. In connection with HTS, methods for generating molecular diversity and for detecting, identifying and quantifying biological or chemical material have been developed. These advances have been facilitated by fundamental developments in chemistry, including the development of highly sensitive analytical methods, solid state chemical synthesis, and sensitive and specific biological assay systems.

Analyses of biological interactions and chemical reactions, however, require the use of labels or tags to track and identify the results of such analyses. Typically biological reactions, such as binding, catalytic, hybridization and signaling reactions, are monitored by labels,

-3-

such as radioactive, fluorescent, photoabsorptive, luminescent and other such labels, or by direct or indirect enzyme labels. Chemical reactions are also monitored by direct or indirect means, such as by linking the reactions to a second reaction in which a colored, fluorescent, chemiluminescent or other such product results. These analytical methods, however, are often time consuming, tedious and, when practiced in vivo, invasive. In addition, each reaction is typically measured individually, in a separate assay. There is, thus, a need to develop alternative and convenient methods for tracking and identifying analytes in biological interactions and the reactants and products of chemical reactions.

#### Combinatorial libraries

The provision and maintenance of compounds to support HTS have become critical. New and innovative methods for the lead generation and lead optimization have emerged to address this need for diversity. Among these methods is combinatorial chemistry, which has become a powerful tool in drug discovery and materials science. Methods and strategies for generating diverse libraries, primarily peptide- and nucleotide-based oligomer libraries, have been developed using molecular biology methods and/or simultaneous chemical synthesis methodologies [see, e.g., Dower et al. (1991) Annu. Rep. Med. Chem. 26:271-280; Fodor et al. (1991) Science 251:767-773; Jung et al. (1992) Angew. Chem. Int. Ed. Engl. 31:367-383; Zuckerman et al. (1992) Proc. Natl. Acad. Sci. USA 89:4505-4509; Scott et al. (1990) Science 249:386-390; Devlin et al. (1990) Science 249:404-406; Cwirla et al. (1990) Proc. Natl. Acad. Sci. USA 87:6378-6382; and Gallop et al. (1994) J. Medicinal Chemistry 37:1233-1251]. The resulting combinatorial libraries potentially contain millions of pharmaceutically relevant compounds and

-4-

that can be screened to identify compounds that exhibit a selected activity.

The libraries fall into roughly three categories: fusion-protein-displayed peptide libraries in which random peptides or proteins are presented on the surface of phage particles or proteins expressed from plasmids; support-bound synthetic chemical libraries in which individual compounds or mixtures of compounds are presented on insoluble matrices, such as resin beads [see, e.g., Lam *et al.* (1991) *Nature* 354:82-84] and cotton supports [see, e.g., Eichler *et al.* (1993) *Biochemistry* 32:11035-11041]; and methods in which the compounds are used in solution [see, e.g., Houghten *et al.* (1991) *Nature* 354:84-86, Houghten *et al.* (1992) *BioTechniques* 313:412-421; and Scott *et al.* (1994) *Curr. Opin. Biotechnol.* 5:40-48]. There are numerous examples of synthetic peptide and oligonucleotide combinatorial libraries. The present direction in this area is to produce combinatorial libraries that contain non-peptidic small organic molecules. Such libraries are based on either a basis set of monomers that can be combined to form mixtures of diverse organic molecules or that can be combined to form a library based upon a selected pharmacophore monomer.

There are three critical aspects in any combinatorial library: (i) the chemical units of which the library is composed; (ii) generation and categorization of the library, and (iii) identification of library members that interact with the target of interest, and tracking intermediary synthesis products and the multitude of molecules in a single vessel.

The generation of such libraries often relies on the use of solid phase synthesis methods, as well as solution phase methods, to produce collections containing tens of millions of compounds that can be screened in diagnostically or pharmacologically relevant *in vitro* assay systems. In

-5-

generating large numbers of diverse molecules by stepwise synthesis, the resulting library is a complex mixture in which a particular compound is present at very low concentrations, so that it is difficult or impossible to determine its chemical structure. Various methods exist for ordered synthesis by sequential addition of particular moieties, or by identifying molecules based on spacial positioning on a chip. These methods are cumbersome and ultimately impossible to apply to highly diverse and large libraries. Identification of library members that interact with a target of interest, and tracking intermediary synthesis products and the multitude of molecules in a single vessel is also a problem.

#### High Throughput Screening

In addition, exploitation of this diversity requires development of methods for rapidly screening compounds. Advances in instrumentation, molecular biology and protein chemistry and the adaptation of biochemical activity screens into microplate formats, has made it possible to screen of large numbers of compounds. Also, because compound screening has been successful in areas of significance for the pharmaceutical industry, high throughput screening (HTS) protocols have assumed importance. Presently, there are hundreds of HTS systems operating throughout the world, which are used, not only for compound screening for drug discovery, but also for immunoassays, cell-based assays and receptor-binding assays.

An essential element of high throughput screening for drug discovery process and areas in which molecules are identified and tracked, is the ability to extract the information made available during synthesis and screening of a library, identification of the active components of intermediary structures, and the reactants and products of assays. While there are several techniques for identification of intermediary products and final products, nanosequencing protocols that

-6-

provide exact structures are only applicable on mass to naturally occurring linear oligomers such as peptides and amino acids. Mass spectrographic [MS] analysis is sufficiently sensitive to determine the exact mass and fragmentation patterns of individual synthesis steps, but

5 complex analytical mass spectrographic strategies are not readily automated nor conveniently performed. Also, mass spectrographic analysis provides at best simple connectivity information, but no stereoisomeric information, and generally cannot discriminate among isomeric monomers. Another problem with mass spectrographic analysis

10 is that it requires pure compounds; structural determinations on complex mixtures is either difficult or impossible. Finally, mass spectrographic analysis is tedious and time consuming. Thus, although there are a multitude of solutions to the generation of libraries and to screening protocols, there are no ideal solutions to the problems of identification,

15 tracking and categorization.

These problems arise in any screening or analytical process in which large numbers of molecules or biological entities are screened. In any system, once a desired molecule(s) has been isolated, it must be identified. Simple means for identification do not exist. Because of the

20 problems inherent in any labeling procedure, it would be desirable to have alternative means for tracking and quantitating chemical and biological reactions during synthesis and/or screening processes, and for automating such tracking and quantitating.

Therefore, it is an object herein to provide methods for

25 identification, tracking and categorization of the components of complex mixtures of diverse molecules. It is also an object herein to provide products for such identification, tracking and categorization and to provide assays, diagnostics and screening protocols that use such



-7-

products. It is of particular interest herein to provide means to track and identify compounds and to perform HTS protocols.

#### **SUMMARY OF THE INVENTION**

Combinations of matrix materials with programmable data storage  
5 or recording devices, herein referred to as memories, and assays using  
these combinations are provided. These combinations are referred to  
herein as matrices with memories. By virtue of this memory with matrix  
combination, molecules, such as antigens, antibodies, ligands, proteins  
and nucleic acids, and biological particles, such as phage and viral  
10 particles and cells, that are associated with, such as in proximity to or in  
physical contact with the matrix combination, can be electromagnetically  
tagged by programming the memory with data corresponding to  
identifying information. Programming and reading the memory is  
effected remotely, preferably using electromagnetic radiation, particularly  
15 radio frequency or radar. Memories may also be remote from the matrix,  
such as instances in which the memory device is precoded with a mark or  
identifier or the matrix is encoded with a bar code. The identity [i.e., the  
mark or code] of each device is written to a memory, which may be a  
computer or a piece of paper or any recording device, and information  
20 associated with each matrix is stored in the remote memory and linked to  
the code or other identifier.

The molecules and biological particles that are associated with the  
matrix combination, such as in proximity to or in physical contact or with  
the matrix combination, can be identified and the results of the assays  
25 determined by retrieving the stored data points from the memories.  
Querying the memory will identify associated molecules or biological  
particles that have reacted.

In certain embodiments of the matrices with memories, reactions,  
assays and other events or external parameters, such as temperature

-8-

and/or pH, can be monitored because occurrence of a reaction or an event can be detected and such detection sent to the recording device and recorded in the memory.

The combinations provided herein thus have a multiplicity of applications, including combinatorial chemistry, isolation and purification of target macromolecules, capture and detection of macromolecules for analytical purposes, high throughput screening, selective removal of contaminants, enzymatic catalysis, drug delivery, chemical modification, information collection and management and other uses. These combinations are particularly advantageous for use in multianalyte analyses, assays in which a electromagnetic signal is generated by the reactants or products in the assay, for use in homogeneous assays, and for use in multiplexed protocols.

In preferred embodiments, these matrix with memory combinations contain (i) a miniature recording device that includes one or more programmable data storage devices [memories] that can be remotely read and in preferred embodiments also remotely programmed; and (ii) a matrix, such as a particulate support used in chemical syntheses.

The matrix materials [matrices] are any materials that are routinely used in chemical and biochemical synthesis. The matrix materials are typically polymeric materials that are compatible with chemical and biological syntheses and assays, and include, glasses, silicates, celluloses, polystyrenes, polysaccharides, polypropylenes, sand, and synthetic resins and polymers, including acrylamides, particularly cross-linked polymers, cotton, and other such materials. The matrices may be in the form of particles or may be continuous in design, such as a test tube or microplate, 96 well or 384 well or higher density formats or other such microplates and microtiter plates. The matrices may contain one or a plurality of recording devices. For example, each well or selected wells

-9-

in the microplate include a memory device in contact therewith or embedded therein. The plates may further contain embedded scintillant or a coating of scintillant [such as FlashPlate™, available from DuPont NEN®, and plates available from Packard, Meriden, CT]. Automated

5 robotic protocols will incorporate such plates for automated multiplexing [performing a series of coupled synthetic and processing steps, typically, though not necessarily on the same platform, i.e. coupling of the chemistry to the biology] including one or more of the following, synthesis, preferably accompanied by writing to the linked memories to

10 identify linked compounds, screening, including using protocols with matrices with memories, and compound identification by querying the memories of matrices associated with the selected compounds.

The matrices are either particulate of a size that is roughly about 1 to 20 mm<sup>3</sup> [or 1-20 mm in its largest dimension], preferably about

15 10 mm<sup>3</sup> or smaller, preferably 1 mm<sup>3</sup> or smaller, or a continuous medium, such as a microtiter plate, or other multi-well plate, or plastic or other solid polymeric vial or glass vial or catheter-tube [for drug delivery] or such container or device conventionally used in chemistry and biological syntheses and reactions. In instances in which the matrix is continuous,

20 the data storage device [memory] may be placed in, on, or under the matrix medium or may be embedded in the material of the matrix.

In embodiments herein in which the matrices with memories are used in assays, such as scintillation proximity assays [SPA], FP [fluorescence polarization] assays, FET [fluorescent energy transfer]

25 assays, FRET [fluorescent resonance energy transfer] assays and HTRF [homogeneous time-resolved fluorescence] assays, the matrices may be coated with, embedded with or otherwise combined with or in contact with assay material, such as scintillant, fluophore or other fluorescent label. The resulting combinations are called luminescing memories with

-10-

matrices. When used in SPA formats they are referred to as scintillating matrices with memories and when used in non-radioactive energy transfer formats [such as HTRF] they are referred to as fluorescing memories with matrices.

- 5** The recording device is preferably a miniature device, typically less than 10-20 mm<sup>3</sup> [or 10-20 mm in its largest dimension] in size, preferably smaller, such as 1 to 5 mm, that includes at least one data storage unit that includes a remotely programmable and remotely readable, preferably non-volatile, memory. This device with remotely programmable memory
- 10** is in proximity to, associated with or in contact with the matrix. In particular, the recording device includes a memory device, preferably having memory means, preferably non-volatile, for storing a plurality of data points and means for receiving a transmitted signal that is received by the device and for causing a data point corresponding to the data signal to be
- 15** permanently stored within the memory means. If needed, the recording device further includes a shell [coating] that is non-reactive with and impervious to any processing steps or solutions in which the combination of matrix with recording device [matrix with memory] is placed, and that is transmissive of read or write signals transmitted to the memory. The
- 20** device may also include at least one support matrix disposed on an outer surface of the shell for retaining molecules or biological particles. The shell and support matrix may be the same. In such instances, the shell must be treated or derivatized such that molecules, particularly amino acids and nucleic acids, can be linked, preferably either electrostatically or
- 25** covalently, thereto. Thus, a transponder enclosed in plastic, must be further treated or coated to render it suitable for linkage of the molecule or biological particle.

The data storage device or memory is programmed with or encoded with information that identifies molecules or biological particles,

-11-

either by their process of preparation, their identity, their batch number, category, physical or chemical properties, combinations of any of such information, or other such identifying information. The molecules or biological particles are in physical contact, direct or indirect, or in proximity with the matrix, which in turn is in physical contact or in the proximity of the recording device that contains the data storage memory. The molecule or biological particle may also be associated, such that a molecule or biological particle that had been linked to or in proximity with a matrix with memory may be identified [i.e., although the matrix particle and biological particle or molecule are not linked or in proximity, the identify of the matrix that had been linked to the molecule or particle is known]. Typically, the matrix is on the surface of the recording device and the molecules and biological particles are in physical contact with the matrix material. In certain embodiments, the memory device may be linked to or in proximity to more than one matrix particle.

The data storage device or memory can also be programmed by virtue of a reaction in proximity to or in the vicinity of the matrix with memory. In particular, the recording devices include memories and also additional components that detect occurrence of external events or to monitor the status of external parameters, such as EM emissions, changes in temperature or pH, ion concentrations and other such solution parameters. For example, recording devices include memories and also include a photodetector can detect the occurrence of fluorescence or other optical emission. Coupling this emission with an amplifier and providing a voltage to permit data storage in the matrix with memory during the reaction by way of, for example an RF signal transmitted to and received by an antenna/rectifier combination within the data storage device or providing voltage sufficient to write to memory from a battery [see, e.g., U.S. Patent No. U.S. Patent No. 5,350,645 and U.S. Patent

-12-

No. 5,089,877], permits occurrence of the emission to be recorded in the memory.

The recording device [containing the memory] is associated with the memory. Typically, the recording device is coated with at least one  
5 layer of material, such as a protective polymer or a glass, including polystyrene, heavy metal-free glass, plastic, ceramic, and may be coated with more than one layers of this and other materials. For example, it may be coated with a ceramic or glass, which is then coated with or linked to the matrix material. Alternatively, the glass or ceramic or other  
10 coating may serve as the matrix. In other embodiments the recording device and the matrix material are in proximity, such as in a container of a size approximately that of the device and matrix material. In yet other embodiments the recording device and matrix material are associated, such that the molecule or biological particle that was linked to the matrix  
15 or that was in proximity thereto may be identified.

The matrix combinations [the memories with matrices], thus, contain a matrix material, typically in particulate form, in physical contact with a tiny device containing one or more remotely programmable data storage units [memories]. Contact can be effected by placing the  
20 recording device with memory on or in the matrix material or in a solution that is in contact with the matrix material or by linking the device, either by direct or indirect covalent or non-covalent interactions, chemical linkages or by other interactions, to the matrix.

For example, such contact is effected chemically, by chemically  
25 coupling the recording device with memory to the matrix, or physically by coating the recording device with the matrix material or another material, by physically inserting or encasing the device in the matrix material, by placing the device onto the matrix or by any other means by which the device can be placed in contact with or in proximity to the matrix

-13-

material. The contact may be direct or indirect via linkers. The contact may be effected by absorption or adsorption.

Since matrix materials have many known uses in conjunction with molecules and biological particles, there are a multitude of methods known to artisans of skill in this art for linking, joining or physically contacting the molecule or biological particle with the matrix material. In some embodiments, the recording device with data storage unit is placed in a solution or suspension of the molecule or biological particle of interest. In some of such instances, the container, such as the microtiter plate or test tube or other vial, is the matrix material. The recording device is placed in or on the matrix or is embedded, encased or dipped in the matrix material or otherwise placed in proximity by enclosing the device and matrix material in a sealed pouch or bag or container [MICROKAN™] fabricated from, preferably, porous material, such as teflon or polypropylene prepared with pores, that is inert to the reaction of interest and that have pores of size permeable to desired components of the reaction medium.

More than one data storage device may be in proximity to or contact with a matrix particle, or more than one matrix particle may be in contact with on device. For example, microplates, such as microtiter plates or other such high density format [i.e. 96 or 384 or more wells per plate, such as those available from Nunc, Naperville, IL, Costar, Cambridge MA, and Millipore, Bedford, MA] with the recording device containing the data storage unit [remotely programmable memory] embedded in each well or vials [typically with a 1 ml or smaller capacity] with an embedded recording device may be manufactured.

In a preferred embodiment, the recording device is a semiconductor that is approximately 10 mm or less in its largest dimension and the matrix material is a particle, such as a polystyrene

-14-

bead. The device and a plurality of particles, referred to as "beads", typically about 1 mg to about 50 mg, but larger size vessels and amounts up to 1000 mg, preferably 50 to about 200 mg, are sealed in chemically inert porous supports, such as polypropylene formed so that it has pores

5 of a selected size that excludes the particles but permits passage of the external medium. For example, a single device and a plurality of particles may be sealed in a porous or semi-permeable inert material to produce a microvessel [such as the MICROKAN™] such as a teflon or polypropylene or membrane that is permeable to the components of the medium, or

10 they may be contained in a small closable container that has at least one dimension that is porous or is a semi-permeable tube. Typically such tube, which preferably has an end that can be opened and sealed or closed tightly. These microvessels preferably have a volume of about 200-500 mm<sup>3</sup>, but can have larger volumes, such as greater than

15 500 mm<sup>3</sup> [or 1000 mm<sup>3</sup>] at least sufficient to contain at least 200 mg of matrix particles, such as about 500-3000 mm<sup>3</sup>, such as 1000-2000 or 1000 to 1500, with preferred dimensions of about 1-10 mm in diameter and 5 to 20 mm in height, more preferably about 5 mm by 15 mm, or larger, such as about 1-6 cm by 1-6 cm. The porous wall should be non-

20 collapsible with a pore size in the range of 70 μM to about 100 μM, but can be selected to be semi-permeable for selected components of the medium in which the microvessel is placed. The preferred geometry of these combinations is cylindrical. These porous microvessels may be sealed by heat or may be designed to snap or otherwise close. In some

25 embodiments they are designed to be reused. In other embodiments, the microvessel MICROKAN™ with closures may be made out of non-porous material, such as a tube in the conical shape or other geometry.

Also provided herein are tubular devices in which the recording devise is enclosed in a solid polymer, such as a polypropylene, which is



-15-

then radiation grafted with selected monomers to produce a surface suitable for chemical synthesis and linkage of molecules or biological particles.

Other devices of interest, are polypropylene supports, generally  
5 about 5-10 mm in the largest dimension, and preferably a cube or other such shape, that are marked with a code, and tracked using a remote memory.

These microvessels can be marked with a code, such as a bar code, alphanumeric code or other mark, for identification, particularly in  
10 embodiments in which the memory is not in proximity to the matrix, but is remote therefrom and used to store information regarding each coded vessel.

The combination of matrix with memory is used by contacting it with, linking it to, or placing it in proximity with a molecule or biological  
15 particle, such as a virus or phage particle, a bacterium or a cell, to produce a second combination of a matrix with memory and a molecule or biological particle. In certain instances, such combinations of matrix with memory or combination of matrix with memory and molecule or biological particle may be prepared when used or may be prepared before  
20 use and packaged or stored as such for future use. The matrix with memory when linked or proximate to a molecule or biological particle is herein referred to as a microreactor.

The miniature recording device containing the data storage unit(s) with remotely programmable memory, includes, in addition to the  
25 remotely programmable memory, means for receiving information for storage in the memory and for retrieving information stored in the memory. Such means is typically an antenna, which also serves to provide power in a passive device when combined with a rectifier circuit to convert received energy, such as RF, into voltage, that can be tuned to

-16-

a desired electromagnetic frequency to program the memory. Power for operation of the recording device may also be provided by a battery attached directly to the recording device, to create an active device, or by other power sources, including light and chemical reactions, including  
5 biological reactions, that generate energy.

Preferred frequencies are any that do not substantially alter the molecular and biological interactions of interest, such as those that are not substantially absorbed by the molecules or biological particles linked to the matrix or in proximity of the matrix, and that do not alter the  
10 support properties of the matrix. Radio frequencies are presently preferred, but other frequencies, such as radar, or optical lasers will be used, as long as the selected frequency or optical laser does not interfere with the interactions of the molecules or biological particles of interest. Thus, information in the form of data points corresponding to such  
15 information is stored in and retrieved from the data storage device by application of a selected electromagnetic radiation frequency, which preferably is selected to avoid interference from any background electromagnetic radiation.

The preferred miniature recording device for use in the  
20 combinations herein is a single substrate of a size preferably less than about 10 to 20 mm<sup>3</sup> [or 10-20 mm in its largest dimension], that includes a remotely programmable data storage unit(s) [memory], preferably a non-volatile memory, and an antenna for receiving or transmitting an electromagnetic signal [and in some embodiments for supplying power in  
25 passive devices when combined with a rectifier circuit] preferably a radio frequency signal; the antenna, rectifier circuit, memory and other components are preferably integrated onto a single substrate, thereby minimizing the size of the device. An active device, i.e., one that does not rely on external sources for providing voltage for operation of the

-17-

memory, may include a battery for power, with the battery attached to the substrate, preferably on the surface of the substrate. Vias through the substrate can then provide conduction paths from the battery to the circuitry on the substrate. The device is rapidly or substantially

5 instantaneously programmable, preferably in less than 5 seconds, more preferably in about 1 second, and more preferably in about 50 to 100 milliseconds or less, and most preferably in about 1 millisecond or less. In a passive device that relies upon external transmissions to generate sufficient voltage to operate, write to and read from an electronic

10 recording device, the preferred memory is non-volatile, permanent, and relies on antifuse-based architecture or flash memory. Other memories, such as electrically programmable erasable read only memories [EEPROMs] based upon other architectures also can be used in passive devices. In active recording devices that have batteries to assure

15 continuous power availability, a broader range of memory devices may be used in addition to those identified above. These memory devices include dynamic random access memories [DRAMs, which refer to semiconductor volatile memory devices that allow random input/output of stored information; see, e.g., U.S. Patent Nos. 5,453,633, 5,451,896,

20 5,442,584, 5,442,212 and 5,440,511], that permit higher density memories, and EEPROMs.

Containers, such as vials, tubes, microtiter plates, capsules and the like, which are in contact with a recording device that includes a data storage unit with programmable memory are also provided. The container

25 is typically of a size used in immunoassays or hybridization reactions, generally a liter or less, typically less than 100 ml, and often less than about 10 ml in volume. Alternatively the container can be in the form of a plurality of wells, such as a microtiter plate, each well having about 1 to 1.5 ml or less in volume. The container is transmissive to the

-18-

electromagnetic radiation, such as radio frequencies, infrared wavelengths, radar, ultraviolet wavelengths, microwave frequencies, visible wavelengths, X-rays or laser light, used to program the recording device.

Methods for electromagnetically tagging molecules or biological particles are provided. Such tagging is effected by placing the molecules or biological particles of interest in proximity with the recording device or with the matrix with memory, and programming or encoding the identity of the molecule or synthetic history of the molecules or batch number or other identifying information into the memory. The, thus identified molecule or biological particle is then used in the reaction or assay of interest and tracked by virtue of its linkage to the matrix with memory, its proximity to the matrix with memory or its having been linked or in proximity to the matrix [i.e., its association with], which can be queried at will to identify the molecule or biological particle. The tagging and/or reaction or assay protocols may be automated. Automation will use robotics with integrated matrix with memory plated based or particulate matrix with memory automation [see, U.S. Patent No. 5,463,564, which provides an automated iterative method of drug design].

In particular, methods for tagging constituent members of combinatorial libraries and other libraries or mixtures of diverse molecules and biological particles are provided. These methods involve electromagnetically tagging molecules, particularly constituent members of a library, by contacting the molecules or biological particles or bringing such molecules or particles into proximity with a matrix with memory and programming the memory with retrievable information from which the identity, synthesis history, batch number or other identifying information can be retrieved. The contact is preferably effected by coating, completely or in part, the recording device with memory with the matrix and then linking, directly or via linkers, the molecule or biological particle of interest to the

-19-

matrix support. The memories can be coated with a protective coating, such as a glass or silicon, which can be readily derivatized for chemical linkage or coupling to the matrix material. In other embodiments, the memories can be coated with matrix, such as for example dipping the  
5 memory into the polymer prior to polymerization, and allowing the polymer to polymerize on the surface of the memory.

If the matrices are used for the synthesis of the constituent molecules, the memory of each particle is addressed and the identity of the added component is encoded in the memory at [before, during, or preferably  
10 after] each step in the synthesis. At the end of the synthesis, the memory contains a retrievable record of all of the constituents of the resulting molecule, which can then be used, either linked to the support, or following cleavage from the support in an assay or for screening or other such application. If the molecule is cleaved from the support with  
15 memory, the memory must remain in proximity to the molecule or must in some manner be traceable [*i.e.*, associated with] to the molecule. Such synthetic steps may be automated.

In preferred embodiments, the matrix with memory with linked molecules [or biological particles] are mixed and reacted with a sample  
20 according to a screening or assay protocol, and those that react are isolated. The identity of reacted molecules can then be ascertained by remotely retrieving the information stored in the memory and decoding it to identify the linked molecules.

Compositions containing combinations of matrices with memories  
25 and compositions of matrices with memories and molecules or biological particles are also provided. In particular, coded or electronically tagged libraries of oligonucleotides, peptides, proteins, non-peptide organic molecules, phage display, viruses and cells are provided. Particulate matrices, such as polystyrene beads, with attached memories, and

-20-

continuous matrices, such as microtiter plates or slabs or polymer, with a plurality of embedded or attached memories are provided.

These combinations of matrix materials with memories and combinations of matrices with memories and molecules or biological particles may be used in any application in which support-bound molecules or biological particles are used. Such applications include, but are not limited to diagnostics, such as immunoassays, drug screening assays, combinatorial chemistry protocols and other such uses. These matrices with memories can be used to tag cells for uses in cell sorting, to identify molecules in combinatorial syntheses, to label monoclonal antibodies, to tag constituent members of phage displays, affinity separation procedures, to label DNA and RNA, in nucleic acid amplification reactions [see, e.g., U.S. Patent No. 5,403,484; U.S. Patent No. 5,386,024; U.S. Patent No. U.S. Patent No. 4,683,202 and, for example International PCT Application WO/94 02634, which describes the use of solid supports in connection with nucleic acid amplification methods], to label known compounds, particularly mixtures of known compounds in multianalyte analyses], to thereby identify unknown compounds, or to label or track unknowns and thereby identify the unknown by virtue of reaction with a known. Thus, the matrices with memories are particularly suited for high throughput screening applications and for multianalyte analyses.

Systems and methods for recording and reading or retrieving the information in the data storage devices regarding the identity or synthesis of the molecules or biological particles are also provided. The systems for recording and reading data include: a host computer or other encoder/decoder instrument having a memory for storing data relating to the identity or synthesis of the molecules, and a transmitter means for receiving a data signal and generating a signal for transmitting a data

-21-

signal; and a recording device that includes a remotely programmable, preferably non-volatile, memory and transmitter means for receiving a data signal and generating at least a transmitted signal and for providing a write signal to the memory in the recording device. The host computer  
5 stores transmitted signals from the memories with matrices, and decodes the transmitted information.

In particular, the systems include means for writing to and reading from the memory device to store and identify each of the indicators that identify or track the molecules and biological particles. The systems addi-  
10 tionally include the matrix material in physical contact with or proximate to the recording device, and may also include a device for separating matrix particles with memory so that each particle or memory can be separately programmed.

Methods for tagging molecules and biological particles by  
15 contacting, either directly or indirectly, a molecule or biological particle with a recording device; transmitting from a host computer or decoder/encoder instrument to the device electromagnetic radiation representative of a data signal corresponding to an indicator that either specifies one of a series of synthetic steps or the identity or other  
20 information for identification of the molecule or biological particle, whereby the data point representing the indicator is written into the memory, are provided.

Methods for reading identifying information from recording devices linked to or in contact with or in proximity to or that had been in contact  
25 with or proximity to a electromagnetically tagged molecule or electromagnetically tagged biological particles are provided. These methods include the step of exposing the recording device containing the memory in which the data are stored to electromagnetic radiation [EM]; and transmitting to a host computer or decoder/encoder instrument an

-22-

indicator representative of a the identity of a molecule or biological particle or identification of the molecule or biological particle linked to, in proximity to or associated with the recording device.

One, two, three and N-dimensional arrays of the matrices with  
5 memories are also provided. Each memory is programmed with its position in the array. Such arrays may be used for blotting, if each matrix particle is coated on one at least one side with a suitable material, such as nitrocellulose. For blotting, each memory is coated on at least one  
10 side with the matrix material and arranged contiguously to adjacent memories to form a substantially continuous sheet. After blotting, the matrix particles may be separated and reacted with the analyte of interest [e.g., a labeled antibody or oligonucleotide or other ligand], after which the physical position of the matrices to which analyte binds may be determined. The amount of bound analyte, as well as the kinetics of the binding  
15 reaction, may also be quantified. Southern, Northern, Western, dot blot and other such assays using such arrays are provided. Dimensions beyond three can refer to additional unique identifying parameters, such as batch number, and simultaneous analysis of multiple blots.

Assays that use combinations of (i) a miniature recording device  
20 that contains one or more programmable data storage devices [memories] that can be remotely programmed and read; and (ii) a matrix, such as a particulate support used in chemical syntheses, are provided. The remote programming and reading is preferably effected using electromagnetic radiation.

25 Also provided are scintillation proximity assays, HTRF, FP, FET and FRET assays in which the memories are in proximity with or are in physical contact with the matrix that contains scintillant for detecting proximate radionucleotide signals or fluorescence. In addition,



-23-

embodiments that include a memory device that also detects occurrence of a reaction are provided.

Molecular libraries, DNA libraries, peptide libraries, biological particle libraries, such as phage display libraries, in which the constituent  
5 molecules or biological particles are combined with a solid support matrix that is combined with a data storage unit with a programmable memory are provided.

Affinity purification protocols in which the affinity resin is combined with a recording device containing a data storage unit with a  
10 programmable memory are also provided.

Immunological, biochemical, cell biological, molecular biological, microbiological, and chemical assays in which memory with matrix combinations are used are provided. For example immunoassays, such as enzyme linked immunosorbent assays [ELISAs] in which at least one  
15 analyte is linked to a solid support matrix that is combined with a recording device containing a data storage unit with a programmable, preferably remotely programmable and non-volatile, memory are provided.

Of particular interest herein, are multiprotocol applications [such as multiplexed assays or coupled synthetic and assay protocols] in which the  
20 matrices with memories are used in a series [more than one] of reactions, a series [more than one] of assays, and/or a series of more or more reactions and one or more assays, typically on a single platform or coupled via automated analysis instrumentation. As a result synthesis is coupled to screening.

## 25 DESCRIPTION OF THE DRAWINGS

FIGURE 1 depicts combinatorial synthesis of chemical libraries on matrix supports with memories. A, B, C . . . represent the chemical building blocks; a, b, c . . . represent the codes stored in memory that

-24-

correspond to each of A, B, C, . . . , respectively.  $S_a, S_b, S_c \dots$  represent respective signals sent to memory.

FIGURE 2 depicts combinatorial synthesis of peptides on a matrix with memory. Each amino acid has a corresponding code, a,b, c . . . , in the matrix memory, and L represents a Linker between the memory  
5 device and the pharmacophore.

FIGURE 3 depicts combinatorial synthesis of oligonucleotides on matrix supports with memories. A, G, T and C represent nucleotides, and a, g, t, and c represent the electronic codes stored in memory that  
10 correspond to each of A, G T and C,, respectively. The phosphoramidite method of oligonucleotide synthesis is performed by methods known to those of skill in the art [see, e.g., Brown et al. (1991) "Modern machine-aided methods of oligodeoxyribonucleotide synthesis" in Oligonucleotides Analogues EDITOR: Eckstein, Fritz (Ed), IRL, Oxford,  
15 UK., pp. 1-24, esp. pp. 4-7].

FIGURE 4 depicts generation of a chemical library, such as a library of organic molecules, in which  $R_1, R_2, R_3$  are substituents on selected molecule, such as a pharmacophore monomer, each identified with a different signal, depicted as 1, 2, or 3, from the classes  $S_1, S_2, S_3,$   
20 respectively. The circle represents an organic pharmacophore. If  $R_1-R_3$  are the same, and selected from among the same 50 choices, then the complete library contains  $50^3 = 125,000$  members. If  $R_1-R_3$  selected from among different sets of choices, then the resulting library has correspondingly more members. Each matrix memory can be encoded  
25 with information that represents the  $R_n$  added and class  $[S_n]$  thereby providing a unique code for each library member.

-25-

FIGURE 5 is a block diagram of the data storage means and supporting electrical components of a preferred embodiment.

FIGURE 6 is a diagrammatic view of the memory array within the recording device, and the corresponding data stored in the host computer  
5 memory.

FIGURE 7 is an illustration of an exemplary apparatus for separating the matrix particles with memories for individual exposure to an EM signal.

FIGURE 8 is an illustration of a second exemplary embodiment of  
10 an apparatus for separating matrix particles for individual exposure to an optical signal.

FIGURE 9 is a diagrammatic view of the memory array within the recording device, the corresponding data stored in the host computer memory, and included photodetector with amplifier and gating transistor.

15 FIGURE 10 is a scheme for the synthesis of the 8 member RF encoded combinatorial decaeric peptide library described in EXAMPLE 4.

All couplings were carried out in DMF at ambient temperature for 1 h [two couplings per amino acid], using PyBOP and EDIA or DIEA. Deprotection conditions: 20% piperidine in DMF, ambient temperature,  
20 30 min; Cleavage conditions: 1,2-ethanedithiol:thioanisole:water:phenol:trifluoroacetic acid [1.5:3:3:4.5:88, w/w], ambient temperature, 1.5 h.

FIGURE 11 is a side elevation of a preferred embodiment of a microvessel.

25 FIGURE 12 is a sectional view, with portions cut away, taken along line 12-12 of FIGURE 11.

FIGURE 13 is a sectional view taken along line 13-13 of FIGURE 12.

-26-

FIGURE 14 is a perspective view of an alternative embodiment of a microvessel, with the end cap separated.

FIGURE 15 is a side elevation view of the microvessel of FIGURE 14, with a portion cut away.

5        FIGURE 16 is a sectional view taken along line 16-16 of FIGURE 15.

FIGURE 17 is a perspective view of an exemplary write/read station.

10       FIGURE 18 is a flow diagram of the operation of the system of FIGURE 17.

Fig. 19 Fluorescent solid supports: application in solid phase synthesis of direct SPA.

Fig. 20 Coded macro "beads" for efficient combinatorial synthesis.

15       Fig. 21 Preparation and use of tubular microvessel in which the container is radiation grafted with monomers for use as a support matrix.

## **DETAILED DESCRIPTION OF PREFERRED EMBODIMENTS**

### **Definitions**

Unless defined otherwise, all technical and scientific terms used herein have the same meaning as is commonly understood by one of skill  
20 in the art to which this invention belongs. All patents and publications referred to herein are, unless noted otherwise, incorporated by reference in their entirety.

As used herein, a matrix refers to any solid or semisolid or insoluble support to which the memory device and/or the molecule of interest,  
25 typically a biological molecule, organic molecule or biospecific ligand is linked or contacted. Typically a matrix is a substrate material having a rigid or semi-rigid surface. In many embodiments, at least one surface of the substrate will be substantially flat, although in some embodiments it may be desirable to physically separate synthesis regions for different

-27-

polymers with, for example, wells, raised regions, etched trenches, or other such topology. Matrix materials include any materials that are used as affinity matrices or supports for chemical and biological molecule syntheses and analyses, such as, but are not limited to: polystyrene,

5 polycarbonate, polypropylene, nylon, glass, dextran, chitin, sand, pumice, teflon, agarose, polysaccharides, dendrimers, buckyballs, polyacrylamide, Kieselguhr-polyacrlamide non-covalent composite, polystyrene-polyacrylamide covalent composite, polystyrene-PEG [polyethyleneglycol] composite, silicon, rubber, and other materials used as supports for solid

10 phase syntheses, affinity separations and purifications, hybridization reactions, immunoassays and other such applications. The matrix herein may be particulate or may be in the form of a continuous surface, such as a microtiter dish or well, a glass slide, a silicon chip, a nitrocellulose sheet, nylon mesh, or other such materials. When particulate, typically

15 the particles have at least one dimension in the 5-10 mm range or smaller. Such particles, referred collectively herein as "beads", are often, but not necessarily, spherical. Such reference, however, does not constrain the geometry of the matrix, which may be any shape, including random shapes, needles, fibers, elongated, etc. The "beads" may include

20 additional components, such as magnetic or paramagnetic particles [see, e.g., Dyna beads (Dynal, Oslo, Norway)] for separation using magnets, fluophores and other scintillants, as long as the additional components do not interfere with chemical reactions, data entry or retrieval from the memory.

25 As used herein, scintillants include, 2,5-diphenyloxazole [PPO], anthracene, 2-(4'-tert-butylphenyl)-5-(4"-biphenyl)-1,3,4-oxadiazole [butyl-PBD]; 1-phenyl-3-mesityl-2-pyrazoline [PMP], with or without frequency shifters, such as 1,4,-bis[5-phenyl(oxazolyl)benzene] [POPOP]; *p*-bis-*o*-methylstyrylbenzene [bis-MSB]. Combinations of these fluors,

-28-

such as PPO and POPOP or PPO and bis-MSB, in suitable solvents, such as benzyltoluene [see, e.g., U.S. Patent No. 5,410,155], are referred to as scintillation cocktails.

As used herein a luminescent moiety refers to a scintillant or  
5 fluophor used in scintillation proximity assays or in non-radioactive energy transfer assays, such as HTRF assays.

As used herein, matrix particles refer to matrix materials that are in the form of discrete particles. The particles have any shape and dimensions, but typically have at least one dimension that is 100 mm or less,  
10 preferably 50 mm or less, more preferably 10 mm or less, and typically have a size that is 100 mm<sup>3</sup> or less, preferably 50 mm<sup>3</sup> or less, more preferably 10 mm<sup>3</sup> or less, and most preferably 1 mm<sup>3</sup> or less. The matrices may also be continuous surfaces, such as microtiter plates [e.g., plates made from polystyrene or polycarbonate or derivatives thereof  
15 commercially available from Perkin Elmer Cetus and numerous other sources, and Covalink trays [Nunc], microtiter plate lids or a test tube, such as a 1 ml Eppendorf tube. Matrices that are in the form of containers refers to containers, such as test tubes and microplates and vials that are typically used for solid phase syntheses of combinatorial libraries  
20 or as pouches, vessels, bags, and microvessels for screening and diagnostic assays. Thus, a container used for chemical syntheses refers to a container that typically has a volume of about 1 liter, generally 100 ml, and more often 10 ml or less, 5 ml or less, preferably 1 ml or less, and as small as about 50  $\mu$ l-500  $\mu$ l, such as 100  $\mu$ l or 250  $\mu$ l. This also refers to  
25 multi-well plates, such as microtiter plates [96 well, 384 well or other density format]. Such microtiter plate will typically contain a recording device in, on, or otherwise in contact with in each of a plurality of wells.

As used herein, a matrix with a memory refers to a combination of a matrix with a miniature recording device that stores multiple bits of data

-29-

by which the matrix may be identified, preferably in a non-volatile memory that can be written to and read from by transmission of electromagnetic radiation from a remote host, such as a computer. By miniature is meant of a size less than about 10-20 mm<sup>3</sup> [or 10-20 mm in the largest  
5 dimension]. Preferred memory devices or data storage units are miniature and are preferably smaller than 10-20 mm<sup>3</sup> [or 10-20 mm in its largest dimension] dimension, more preferably less than 5 mm<sup>3</sup>, most preferably about 1 mm<sup>3</sup> or smaller.

As used herein, a microreactor refers to combinations of matrices  
10 with memories with associated, such as linked or proximate, biological particles or molecules. It is produced, for example, when the molecule is linked thereto or synthesized thereon. It is then used in subsequent protocols, such as immunoassays and scintillation proximity assays.

As used herein, a combination herein called a microvessel [e.g., an  
15 MICROKAN<sup>TM</sup>] refers to a combination in which a single device [or more than one device] and a plurality of particles are sealed in a porous or semi-permeable inert material, such as teflon or polypropylene or membrane that is permeable to the components of the medium, but retains the particles and memory, or are sealed in a small closable container that has  
20 at least one dimension that is porous or semi-permeable. Typically such microvessels, which preferably have at least one end that can be opened and sealed or closed tightly, has a volume of about 200-500 mm<sup>3</sup>, with preferred dimensions of about 1-10 mm in diameter and 5 to 20 mm in height, more preferably about 5 mm by 15 mm. The porous wall should  
25 be non-collapsible with a pore size in the range of 70 μM to about 100 μM, but can be selected to be semi-permeable for selected components of the reaction medium.

As used herein, a memory is a data storage unit [or medium] with programmable memory, preferably a non-volatile memory.

-30-

As used herein, programming refers to the process by which data or information is entered and stored in a memory. A memory that is programmed is a memory that contains retrievable information.

As used herein, remotely programmable, means that the memory  
5 can be programmed without direct physical or electrical contact or can be programmed from a distance, typically at least about 10 mm, although shorter distances may also be used, such as instances in which the information comes from surface or proximal reactions or from an adjacent memory or in instances, such as embodiments in which the memories are  
10 very close to each other, as in microtiter plate wells or in an array.

As used herein, a recording device [or memory device] is an apparatus that includes the data storage unit with programmable memory, and, if necessary, means for receiving information and for transmitting information that has been recorded. It includes any means  
15 needed or used for writing to and reading from the memory. The recording devices intended for use herein, are miniature devices that preferably are smaller than 10-20 mm<sup>3</sup> [or 10-20 mm in their largest dimension], and more preferably are closer in size to 1 mm<sup>3</sup> or smaller that contain at least one such memory and means for receiving and  
20 transmitting data to and from the memory.

As used herein, a data storage unit with programmable memory includes any data storage means having the ability to record multiple discrete bits of data, which discrete bits of data may be individually accessed [read] after one or more recording operations. Thus, a matrix  
25 with memory is a combination of a matrix material with a miniature data storage unit.

As used herein, programmable means capable of storing unique data points. Addressable means having unique locations that may be selected for storing the unique data points.



-31-

As used herein, reaction verifying and reaction detecting are interchangeable and refer to the combination that also includes elements that detect occurrence of a reaction or event of interest between the associated molecule or biological particle and its environment [i.e.,  
5 detects occurrence of a reaction, such as ligand binding, by virtue of emission of EM upon reaction or a change in pH or temperature or other parameter].

As used herein, a host computer or decoder/encoder instrument is an instrument that has been programmed with or includes information  
10 [i.e., a key] specifying the code used to encode the memory devices. This instrument or one linked thereto transmits the information and signals to the recording device and it, or another instrument, receives the information transmitted from the recording device upon receipt of the appropriate signal. This instrument thus creates the appropriate signal to  
15 transmit to the recording device and can interpret transmitted signals. For example, if a "1" is stored at position 1,1 in the memory of the recording device means, upon receipt of this information, this instrument or computer can determine that this means the linked molecule is, for example, a peptide containing alanine at the N-terminus, an organic  
20 group, organic molecule, oligonucleotide, or whatever this information has been predetermined to mean. Alternatively, the information sent to and transmitted from the recording device can be encoded into the appropriate form by a person.

As used herein, an electromagnetic tag is a recording device that  
25 has a memory that contains unique data points that correspond to information that identifies molecules or biological particles linked to, directly or indirectly, in physical contact with or in proximity [or associated with] to the device. Thus, electromagnetic tagging is the process by which identifying or tracking information is transmitted [by

-32-

any means and to any recording device memory, including optical and magnetic storage media] to the recording device.

As used herein, proximity means within a very short distance, generally less than 0.5 inch, typically less than 0.2 inches. In particular, 5 stating that the matrix material and memory, or the biological particle or molecule and matrix with memory are in proximity means that, they are at least or at least were in the same reaction vessel or, if the memory is removed from the reaction vessel, the identity of the vessel containing the molecules or biological particles with which the memory was 10 proximate or linked is tracked or otherwise known.

As used herein, associated with means that the memory must remain in proximity to the molecule or biological particle or must in some manner be traceable to the molecule or biological particle. For example, if a molecule is cleaved from the support with memory, the memory must in 15 some manner be identified as having been linked to the cleaved molecule. Thus, a molecule or biological particle that had been linked to or in proximity to a matrix with memory is associated with the matrix or memory if it can be identified by querying the memory.

As used herein, antifuse refers to an electrical device that is initially 20 an open circuit that becomes a closed circuit during programming, thereby providing for non-volatile memory means and, when accompanied by appropriate transceiver and rectification circuitry, permitting remote programming and, hence identification. In practice, an antifuse is a substantially nonconductive structure that is capable of becoming 25 substantially conductive upon application of a predetermined voltage, which exceeds a threshold voltage. An antifuse memory does not require a constant voltage source for refreshing the memory and, therefore, may be incorporated in a passive device. Other memories that may be used include, but are not limited to: EEPROMS, DRAMS and flash memories.

-33-

As used herein, flash memory is memory that retains information when power is removed [see, e.g., U.S. Patent No. 5,452,311, U.S. Patent No. 5,452,251 and U.S. Patent No. 5,449,941]. Flash memory can be rewritten by electrically and collectively erasing the stored data, and then by programming.

As used herein, passive device refers to an electrical device which does not have its own voltage source and relies upon a transmitted signal to provide voltage for operation.

As used herein, electromagnetic [EM] radiation refers to radiation understood by skilled artisans to be EM radiation and includes, but is not limited to radio frequency [RF], infrared [IR], visible, ultraviolet [UV], radiation, sonic waves, X-rays, and laser light.

As used herein, information identifying or tracking a biological particle or molecule, refers to any information that identifies the molecule or biological particle, such as, but not limited to the identity particle [i.e. its chemical formula or name], its sequence, its type, its class, its purity, its properties, such as its binding affinity for a particular ligand. Tracking means the ability to follow a molecule or biological particle through synthesis and/or process steps. The memory devices herein store unique indicators that represent any of this information.

As used herein, combinatorial chemistry is a synthetic strategy that produces diverse, usually large, chemical libraries. It is the systematic and repetitive, covalent connection of a set, the basis set, of different monomeric building blocks of varying structure to each other to produce an array of diverse molecules [see, e.g., Gallop et al. (1994) J. Medicinal Chemistry 37:1233-1251]. It also encompasses other chemical modifications, such as cyclizations, eliminations, cleavages, etc., that are carried in manner that generates permutations and thereby collections of diverse molecules.

-34-

As used herein, a biological particle refers to a virus, such as a viral vector or viral capsid with or without packaged nucleic acid, phage, including a phage vector or phage capsid, with or without encapsulated nucleotide acid, a single cell, including eukaryotic and prokaryotic cells or  
5 fragments thereof, a liposome or micellar agent or other packaging particle, and other such biological materials.

As used herein, the molecules in the combinations include any molecule, including nucleic acids, amino acids, other biopolymers, and other organic molecules, including peptidomimetics and monomers or  
10 polymers of small organic molecular constituents of non-peptidic libraries, that may be identified by the methods here and/or synthesized on matrices with memories as described herein.

As used herein, the term "bio-oligomer" refers to a biopolymer of less than about 100 subunits. A bio-oligomer includes, but is not limited  
15 to, a peptide, i.e., containing amino acid subunits, an oligonucleotide, i.e., containing nucleoside subunits, a peptide-oligonucleotide chimera, peptidomimetic, and a polysaccharide.

As used herein, the term "sequences of random monomer subunits" refers to polymers or oligomers containing sequences of  
20 monomers in which any monomer subunit may precede or follow any other monomer subunit.

As used herein, the term "library" refers to a collection of substantially random compounds or biological particles expressing random peptides or proteins or to a collection of diverse compounds. Of particular interest  
25 are bio-oligomers, biopolymers, or diverse organic compounds or a set of compounds prepared from monomers based on a selected pharmacophore.

As used herein, an analyte is any substance that is analyzed or assayed in the reaction of interest. Thus, analytes include the substrates,

-35-

products and intermediates in the reaction, as well as the enzymes and cofactors.

As used herein, multianalyte analysis is the ability to measure many analytes in a single specimen or to perform multiple tests from a single specimen. The methods and combinations herein provide means to  
5 identify or track individual analytes from among a mixture of such analytes.

As used herein, a fluophore or a fluor is a molecule that readily fluoresces; it is a molecule that emits light following interaction with  
10 radiation. The process of fluorescence refers to emission of a photon by a molecule in an excited singlet state. For scintillation assays, combinations of fluors are typically used. A primary fluor that emits light following interaction with radiation and a secondary fluor that shifts the wavelength emitted by the primary fluor to a higher more efficiently  
15 detected wavelength.

As used herein, a peptidomimetic is a compound that mimics the conformation and certain stereochemical features of the biologically active form of a particular peptide. In general, peptidomimetics are designed to mimic certain desirable properties of a compound but not the  
20 undesirable features, such as flexibility leading to a loss of the biologically active conformation and bond breakdown. For example, methylenethio bioisostere [CH<sub>2</sub>S] has been used as an amide replacement in enkephalin analogs [see, e.g., Spatola, A.F. Chemistry and Biochemistry of Amino Acids, Peptides, and Proteins [Weinstein, B, Ed., Vol. 7, pp. 267-357,  
25 Marcel Dekker, New York (1983); and Szelke et al. (1983) In Peptides: Structure and Function, Proceedings of the Eighth American Peptide Symposium, Hruby and Rich, Eds., pp. 579-582, Pierce Chemical Co., Rockford, Illinois].

As used herein, complete coupling means that the coupling  
30 reaction is driven substantially to completion despite or regardless of the

-36-

differences in the coupling rates of individual components of the reaction, such as amino acids. In addition, the amino acids, or whatever is being coupled, are coupled to substantially all available coupling sites on the solid phase support so that each solid phase support will contain

5 essentially only one species of peptide.

As used herein, the biological activity or bioactivity of a particular compound includes any activity induced, potentiated or influenced by the compound in vivo or in vitro. It also includes the abilities, such as the ability of certain molecules to bind to particular receptors and to induce

10 [or modulate] a functional response. It may be assessed by in vivo assays or by in vitro assays, such as those exemplified herein.

As used herein, pharmaceutically acceptable salts, esters or other derivatives of the compounds include any salts, esters or derivatives that may be readily prepared by those of skill in this art using known methods

15 for such derivatization and that produce compounds that may be administered to animals or humans without substantial toxic effects and that either are pharmaceutically active or are prodrugs. For example, hydroxy groups can be esterified or etherified.

As used herein, substantially pure means sufficiently homogeneous

20 to appear free of readily detectable impurities as determined by standard methods of analysis, such as thin layer chromatography [TLC], mass spectrometry [MS], size exclusion chromatography, gel electrophoresis, particularly agarose and polyacrylamide gel electrophoresis [PAGE] and high performance liquid chromatography [HPLC], used by those of skill in

25 the art to assess such purity, or sufficiently pure such that further purification would not detectably alter the physical and chemical properties, such as enzymatic and biological activities, of the substance. Methods for purification of the compounds to produce substantially chemically pure compounds are known to those of skill in the art. A

30 substantially chemically pure compound may, however, be a mixture of

-37-

stereoisomers. In such instances, further purification might increase the specific activity of the compound.

As used herein, adequately pure or "pure" per se means sufficiently pure for the intended use of the adequately pure compound.

5 As used herein, biological activity refers to the in vivo activities of a compound or physiological responses that result upon in vivo administration of a compound, composition or other mixture. Biological activity, thus, encompasses therapeutic effects and pharmaceutical activity of such compounds, compositions and mixtures.

10 As used herein, a prodrug is a compound that, upon in vivo administration, is metabolized or otherwise converted to the biologically, pharmaceutically or therapeutically active form of the compound. To produce a prodrug, the pharmaceutically active compound is modified such that the active compound will be regenerated by metabolic  
15 processes. The prodrug may be designed to alter the metabolic stability or the transport characteristics of a drug, to mask side effects or toxicity, to improve the flavor of a drug or to alter other characteristics or properties of a drug. By virtue of knowledge of pharmacodynamic processes and drug metabolism in vivo, those of skill in this art, once a pharmaceutically active compound is known, can design prodrugs of the compound  
20 [see, e.g., Nogrady (1985) Medicinal Chemistry A Biochemical Approach, Oxford University Press, New York, pages 388-392].

As used herein, amino acids refer to the naturally-occurring amino acids and any other non-naturally occurring amino acids, and also the  
25 corresponding D-isomers. It is also understood that certain amino acids may be replaced by substantially equivalent non-naturally occurring variants thereof, such as D-Nva, D-Nle, D-Alle, and others listed with the abbreviations below or known to those of skill in this art.

As used herein, hydrophobic amino acids include Ala, Val, Leu, Ile,  
30 Pro, Phe, Trp, and Met, the non-naturally occurring amino acids and the

-38-

corresponding D isomers of the hydrophobic amino acids, that have similar hydrophobic properties; the polar amino acids include Gly, Ser, Thr, Cys, Tyr, Asn, Gln, the non-naturally occurring amino acids and the corresponding D isomers of the polar amino acids, that have similar  
5 properties, the charged amino acids include Asp, Glu, Lys, Arg, His, the non-naturally occurring amino acids and the corresponding D isomers of these amino acids.

As used herein, Southern, Northern, Western and dot blot procedures refer to those in which DNA, RNA and protein patterns,  
10 respectively, are transferred for example, from agarose gels, polyacrylamide gels or other suitable medium that constricts convective motion of molecules, to nitrocellulose membranes or other suitable medium for hybridization or antibody or antigen binding are well known to those of skill in this art [see, e.g., Southern (1975) J. Mol. Biol. 98:503-  
15 517; Ketner et al. (1976) Proc. Natl. Acad. Sci. U.S.A. 73:1102-1106; Towbin et al. (1979) Proc. Natl. Acad. Sci. U.S.A. 76:4350].

As used herein, a receptor refers to a molecule that has an affinity for a given ligand. Receptors may be naturally-occurring or synthetic molecules. Receptors may also be referred to in the art as anti-ligands.  
20 As used herein, both terms, receptor and anti-ligand are interchangeable. Receptors can be used in their unaltered state or as aggregates with other species. Receptors may be attached, covalently or noncovalently, or in physical contact with, to a binding member, either directly or indirectly via a specific binding substance or linker. Examples of receptors, include,  
25 but are not limited to: antibodies, cell membrane receptors surface receptors and internalizing receptors, monoclonal antibodies and antisera reactive with specific antigenic determinants [such as on viruses, cells, or other materials], drugs, polynucleotides, nucleic acids, peptides, cofactors, lectins, sugars, polysaccharides, cells, cellular membranes, and  
30 organelles.



-39-

Examples of receptors and applications using such receptors, include but are not restricted to:

- a) enzymes: specific transport proteins or enzymes essential to survival of microorganisms, which could serve as targets for antibiotic  
5 [ligand] selection;
- b) antibodies: identification of a ligand-binding site on the antibody molecule that combines with the epitope of an antigen of interest may be investigated; determination of a sequence that mimics an antigenic  
10 epitope may lead to the development of vaccines of which the immunogen is based on one or more of such sequences or lead to the development of related diagnostic agents or compounds useful in therapeutic treatments such as for auto-immune diseases
- c) nucleic acids: identification of ligand, such as protein or RNA, binding sites;
- 15 d) catalytic polypeptides: polymers, preferably polypeptides, that are capable of promoting a chemical reaction involving the conversion of one or more reactants to one or more products; such polypeptides generally include a binding site specific for at least one reactant or reaction intermediate and an active functionality proximate to the binding  
20 site, in which the functionality is capable of chemically modifying the bound reactant [see, e.g., U.S. Patent No. 5,215,899];
- e) hormone receptors: determination of the ligands that bind with high affinity to a receptor is useful in the development of hormone replacement therapies; for example, identification of ligands that bind to  
25 such receptors may lead to the development of drugs to control blood pressure; and
- f) opiate receptors: determination of ligands that bind to the opiate receptors in the brain is useful in the development of less-addictive replacements for morphine and related drugs.

-40-

As used herein, antibody includes antibody fragments, such as Fab fragments, which are composed of a light chain and the variable region of a heavy chain.

As used herein, complementary refers to the topological  
5 compatibility or matching together of interacting surfaces of a ligand molecule and its receptor. Thus, the receptor and its ligand can be described as complementary, and furthermore, the contact surface characteristics are complementary to each other.

As used herein, a ligand-receptor pair or complex formed when two  
10 macromolecules have combined through molecular recognition to form a complex.

As used herein, an epitope refers to a portion of an antigen molecule that is delineated by the area of interaction with the subclass of receptors known as antibodies.

As used herein, a ligand is a molecule that is specifically recognized  
15 by a particular receptor. Examples of ligands, include, but are not limited to, agonists and antagonists for cell membrane receptors, toxins and venoms, viral epitopes, hormones [e.g., steroids], hormone receptors, opiates, peptides, enzymes, enzyme substrates, cofactors, drugs, lectins,  
20 sugars, oligonucleotides, nucleic acids, oligosaccharides, proteins, and monoclonal antibodies.

As used herein, a sensor is a device or apparatus that monitors external parameters (i.e., conditions), such as ion concentrations, pH, temperatures. Biosensors are sensors that detect biological species.  
25 Sensors encompass devices that rely on electrochemical, optical, biological and other such means to monitor the environment.

As used herein, multiplexing refers to performing a series of synthetic and processing steps and/or assaying steps on the same platform [i.e. solid support or matrix] or coupled together as part of the  
30 same automated coupled protocol, including one or more of the following.

-41-

synthesis, preferably accompanied by writing to the linked memories to identify linked compounds, screening, including using protocols with matrices with memories, and compound identification by querying the memories of matrices associated with the selected compounds. Thus, 5 the platform refers system in which all manipulations are performed. In general it means that several protocols are coupled and performed sequentially or simultaneously.

As used herein, a platform refers to the instrumentation or devices in which on which a reaction or series of reactions is(are) performed.

10 As used herein a protecting group refers to a material that is chemically bound to a monomer unit that may be removed upon selective exposure to an activator such as electromagnetic radiation and, especially ultraviolet and visible light, or that may be selectively cleaved. Examples of protecting groups include, but are not limited to: those 15 containing nitropiperonyl, pyrenylmethoxy-carbonyl, nitroveratryl, nitrobenzyl, dimethyl dimethoxybenzyl, 5-bromo-7-nitroindolinyl, o-hydroxy- alpha -methyl cinnamoyl, and 2-oxymethylene anthraquinone.

Also protected amino acids are readily available to those of skill in this art. For example, Fmoc and Boc protected amino acids can be 20 obtained from Fluka, Bachem, Advanced Chemtech, Sigma, Cambridge Research Biochemical, Bachem, or Peninsula Labs or other chemical companies familiar to those who practice this art.

As used herein, the abbreviations for amino acids and protective groups are in accord with their common usage and the IUPAC-IUB 25 Commission on Biochemical Nomenclature [see, (1972) Biochem. 11: 942-944]. Each naturally occurring L-amino acid is identified by the standard three letter code or the standard three letter code with or without the prefix "L-"; the prefix "D-" indicates that the stereoisomeric form of the amino acid is D. For example, as used herein, Fmoc is 9- 30 fluorenylmethoxycarbonyl; BOP is benzotriazol-1-yloxytris(dimethylamino)

-42-

phosphonium hexafluorophosphate, DCC is dicyclohexylcarbodiimide; DDZ is dimethoxydimethylbenzyloxy; DMT is dimethoxytrityl; Fmoc is fluorenylmethyloxycarbonyl; HBTU is 2-(1H-benzotriazol-1-yl)-1,1,3,3-tetramethyluronium; hexafluorophosphate NV is nitroveratryl; NVOC is 6-nitroveratryloxycarbonyl and other photoremovable groups; TFA is trifluoroacetic acid; DMF for N,N-dimethylformamide; Boc is *tert*-butoxycarbonyl; TFA for trifluoroacetic acid; HF for hydrogen fluoride; HFIP for hexafluoroisopropanol; HPLC for high performance liquid chromatography; FAB-MS for fast atom bombardment mass spectrometry; DCM is dichloromethane, Bom is benzyloxymethyl; Pd/C is palladium catalyst on activated charcoal; DIC is diisopropylcarbodiimide; DCC is N,N'-dicyclohexylcarbodiimide; [For] is formyl; PyBop is benzotriazol-1-yl-oxy-trispyrrolidino-phosphonium hexafluorophosphate; POPOP is 1,4-bis[5-phenyl(oxazolyl)benzene]; PPO is 2,5-diphenyloxazole; butyl-PBD is [2-(4'-tert-butylphenyl)-5-(4"-biphenyl)-1,3,4-oxadiazole]; PMP is (1-phenyl-3-mesityl-2-pyrazoline) DIEA is diisopropylethylamine; EDIA is ethyldiisopropylethylamine; NMP is N-methylpyrrolidone; NV is nitroveratryl PAL is pyridylalanine; HATU is O(7-azabenzotriazol-1-yl)-1,1,3,3-tetramethyluronium hexafluorophosphate; TFA is trifluoroacetic acid, THF is tetrahydrofuran; and EDT is 1,2-ethanedithiol.

#### A. Matrices

Matrices, which are generally insoluble materials used to immobilize ligands and other molecules, have application in many chemical syntheses and separations. Matrices are used in affinity chromatography, in the immobilization of biologically active materials, and during chemical syntheses of biomolecules, including proteins, amino acids and other organic molecules and polymers. The preparation of and use of matrices is well known to those of skill in this art; there are many such materials and preparations thereof known. For example, naturally-occurring matrix materials, such as agarose and cellulose, may be isolated from their

-43-

respective sources, and processed according to known protocols, and synthetic materials may be prepared in accord with known protocols.

Matrices include any material that can act as a support matrix for attachment of the molecules or biological particles of interest and can be  
5 in contact with or proximity to or associated with, preferably encasing or coating, the data storage device with programmable memory. Any matrix composed of material that is compatible with and upon or in which chemical syntheses are performed, including biocompatible polymers, is suitable for use herein. The matrix material should be selected so that it  
10 does not interfere with the chemistry or biological reaction of interest during the time which the molecule or particle is linked to, or in proximity therewith [see, e.g., U.S. Patent No. 4,006,403]. These matrices, thus include any material to which the data storage device with memory can be attached, placed in proximity thereof, impregnated, encased or  
15 otherwise connected, linked or physically contacted. Such materials are known to those of skill in this art, and include those that are used as a support matrix. These materials include, but are not limited to, inorganics, natural polymers, and synthetic polymers, including, but are not limited to: cellulose, cellulose derivatives, acrylic resins, glass, silica  
20 gels, polystyrene, gelatin, polyvinyl pyrrolidone, co-polymers of vinyl and acrylamide, polystyrene cross-linked with divinylbenzene or the like [see, Merrifield (1964) Biochemistry 3:1385-1390], polyacrylamides, latex gels, polystyrene, dextran, polyacrylamides, rubber, silicon, plastics, nitrocellulose, celluloses, natural sponges, and many others.

25 Among the preferred matrices are polymeric beads, such as the TENTAGEL™ resins and derivatives thereof [sold by Rapp Polymere, Tubingen, Germany; see, U.S. Patent No. 4,908,405 and U.S. Patent No. 5,292,814; see, also Butz et al. (1994) Peptide Res. 7:20-23; Kleine et al. (1994) Immunobiol. 190:53-66; see, also Piskin et al. (1994), Chapter  
30 18 "Nondegradable and Biodegradable Polymeric Particles" in Diagnostic

- Biosensor Polymers, ACS Symp. Series 556, Usmani et al. Eds, American Chemical Society, Washington, DC], which are designed for solid phase chemistry and for affinity separations and purifications. See, also Bayer et al. (1994) in Pept.: Chem., Struct. Biol., Proc. Am. Pept. Symp.,
- 5 13th; Hodges, et al. eds., pp.156-158; Zhang et al. (1993) Pept. 1992, Proc. Eur. Pept. Symp., 22nd, Schneider, et al., eds. pp. 432-433; Ilg et al. (1994) Macromolecules, pp. 2778-83; Zeppezauer et al. (1993) Z. Naturforsch., B: Chem. Sci. 48:1801-1806; Rapp et al. (1992) Pept. Chem. 1992, Proc. Jpn. Symp., 2nd, Yanaihara, ed., pp. 7-10; Nokihara
- 10 et al. (1993) Shimadzu Hyoron 50:25-31; Wright et al. (1993) Tetrahedron Lett. 34:3373-3376; Bayer et al. (1992) Poly(Ethylene Glycol) Chem. Harris, ed., pp. 325-45; Rapp et al. (1990) Innovation Perspect. Solid Phase Synth. Collect. Pap., Int. Symp., 1st, Epton, ed., pp. 205-10; Rapp et al. (1992) Pept.: Chem. Biol., Proc. Am. Pept.
- 15 Symp., 12th, Smith et al., eds., pp. 529-530; Rapp et al. (1989) Pept., Proc. Eur. Pept. Symp., 20th, Jung et al., ed., pp. 199-201; Bayer et al. (1986) Chem. Pept. Proteins 3: 3-8; Bayer et al. (1983) Pept.: Struct. Funct., Proc. Am. Pept. Symp., 8th, Hruby et al. eds., pp. 87-90 for descriptions of preparation of such beads and use thereof in synthetic
- 20 chemistry. Matrices that are also contemplated for use herein include fluophore-containing or -impregnated matrices, such as microplates and beads [commercially available, for example, from Amersham, Arlington Heights, IL; plastic scintillation beads from NE (Nuclear Technology, Inc., San Carlos, CA), Packard, Meriden, CT]. It is understood that these
- 25 commercially available materials will be modified by combining them with memories, such as by methods described herein.

The matrix may also be a relatively inert polymer, which can be grafted by ionizing radiation [see, e.g., Figure 21, which depicts a particular embodiment] to permit attachment of a coating of polystyrene

30 or other such polymer that can be derivatized and used as a support.

-45-

Radiation grafting of monomers allows a diversity of surface characteristics to be generated on plasmid supports [see, e.g., Maeji *et al.* (1994) *Reactive Polymers* 22:203-212; and Berg *et al.* (1989) *J. Am. Chem. Soc.* 111:8024-8026]. For example, radiolytic grafting of

5 monomers, such as vinyl monomers, or mixtures of monomers, to polymers, such as polyethylene and polypropylene, produce composites that have a wide variety of surface characteristics. These methods have been used to graft polymers to insoluble supports for synthesis of peptides and other molecules, and are of particular interest herein. The

10 recording devices, which are often coated with a plastic or other insert material, can be treated with ionizing radiation so that selected monomers can be grafted to render the surface suitable for chemical syntheses.

Where the matrix particles are macroscopic in size, such as about at least 1 mm in at least one dimension, such bead or matrix particle or

15 continuous matrix, may contain one or more memories. Where the matrix particles are smaller, such as NE particles [PVT-based plastic scintillator microsphere], which are about 1 to 10  $\mu\text{m}$  in diameter, more than one such particle will generally be associated with one memory. Also, the bead may include additional material, such as scintillant or a fluophore

20 impregnated therein. In preferred embodiments, the solid phase chemistry and subsequent assaying may be performed on the same bead or matrix with memory combination. All procedures, including synthesis on the bead and assaying and analysis, can be automated.

The matrices are typically insoluble substrates that are solid,

25 porous, deformable, or hard, and have any required structure and geometry, including, but not limited to: beads, pellets, disks, capillaries, hollow fibers, needles, solid fibers, random shapes, thin films and membranes. Typically, when the matrix is particulate, the particles are at least about 10-2000  $\mu\text{m}$ , but may be smaller, particularly for use in

30 embodiments in which more than one particle is in proximity to a

-46-

memory. For purposes herein, the support material will typically encase or be in contact with the data storage device, and, thus, will desirably have at least one dimension on the order of 1 mm [1000  $\mu$ M] or more, although smaller particles may be contacted with the data storage

5 devices, particularly in embodiments in which more than one matrix particle is associated, linked or in proximity to one memory or matrix with memory, such as the microvessels [see, e.g., FIGS. 11-16]. Each memory will be in associated with, in contact with or proximity to at least one matrix particle, and may be in contact with more than one. As

10 smaller semiconductor and electronic or optical devices become available, the capacity of the memory can be increased and/or the size of the particles can be decreased. For example, presently, 0.5 micron semiconductor devices are available. Integrated circuits 0.25-micron in size have been described and are being developed using a technology

15 called the Complementary Metal Oxide-Semiconductor process (see, e.g., Investor's Business Daily 5/30/95).

Also of interest herein, are devices that are prepared by inserting the recording device into a "tube" [see, e.g., Figure 21] or encasing them in an inert material [with respect to the media in which the device will be

20 in contact]. This material is fabricated from a plastic or other inert material. Preferably prior to introducing [and preferably sealing] the recording device inside, the tube or encasing material is treated with ionizing radiation to render the surface suitable for grafting selected monomers, such as styrene [see, e.g., Maeji et al. (1994) Reactive

25 Polymers 22:203-212; and Berg et al. (1989) J. Am. Chem. Soc. 111:8024-8026].

Recording device(s) is(are) introduced inside the material or the material is wrapped around the device and the resulting memory with matrix "tubes" [MICROTUBES<sup>™</sup>, see, FIGURE 21] are used for chemical

30 synthesis or linkage of selected molecules or biological particles. These



-47-

"tubes" are preferably synthesized from an inert resin, such as a polypropylene resin [e.g., a Moplen resin, V29G PP resin from Montell, Newark DE, a distributor for Himont, Italy]. Any inert matrix that can then be functionalized or to which derivatizable monomers can be grafted

5 is suitable. Preferably herein, polypropylene tubes are grafted and then formed into tubes or other suitable shape and the recording device inserted inside. These tubes [MICROTUBES™] with grafted monomers are then used as synthesis, and/or for assays or for multiplexed processes, including synthesis and assays or other multistep procedures.

10 Also larger matrix particles, which advantageously provide ease of handling, may be used and may be in contact with or proximity to more than one memory (i.e., one particle may have a plurality of memories in proximity or linked to it; each memory may be programmed with different data regarding the matrix particle, linked molecules, synthesis or assay

15 protocol, etc.]. Thus, so-called macro-beads (Rapp Polymere, Tubingen, Germany), which have a diameter of 2 mm when swollen, or other matrices of such size, are also contemplated for use herein. Particles of such size can be readily manipulated and the memory can be readily impregnated in or on the bead. These beads (available from Rapp) are

20 also advantageous because of their uniformity in size, which is useful when automating the processes for electronically tagging and assaying the beads.

The matrices may also include an inert strip, such as a teflon strip or other material to which the molecules or biological particles of interest

25 do not adhere, to aid in handling the matrix, such as embodiments in which a matrix with memory and linked molecules or biological particle are introduced into an agar-containing plate for immunoassays or for antibiotic screening.

Selection of the matrices will be governed, at least in part, by their

30 physical and chemical properties, such as solubility, functional groups,

-48-

mechanical stability, surface area swelling propensity, hydrophobic or hydrophilic properties and intended use.

The data storage device with programmable memory may be coated with a material, such as a glass or a plastic, that can be further derivatized and used as the support or it may be encased, partially or completely, in the matrix material, such as during or prior to polymerization of the material. Such coating may be performed manually or may be automated. The coating can be effected manually or using instruments designed for coating such devices. Instruments for this purpose are available [see, e.g., the Series C3000 systems for dipping available from Specialty Coating Systems, Inc., Indianapolis, IN; and the Series CM 2000 systems for spray coating available from Integrated Technologies, Inc. Acushnet, MA].

The data storage device with memory may be physically inserted into the matrix material or particle. It also can be manufactured with a coating that is suitable for use as a matrix or that includes regions in the coating that are suitable for use as a matrix. If the matrix material is a porous membrane, it may be placed inside the membrane. It is understood that when the memory device is encased in the matrix or coated with protective material, such matrix or material must be transparent to the signal used to program the memory for writing or reading data. More than one matrix particle may be linked to each data storage device.

In some instances, the data storage device with memory is coated with a polymer, which is then treated to contain an appropriate reactive moiety or in some cases the device may be obtained commercially already containing the reactive moiety, and may thereby serve as the matrix support upon which molecules or biological particles are linked. Materials containing reactive surface moieties such as amino silane linkages, hydroxyl linkages or carboxysilane linkages may be produced by well established surface chemistry techniques involving silanization reactions,

-49-

or the like. Examples of these materials are those having surface silicon oxide moieties, covalently linked to gamma-aminopropylsilane, and other organic moieties; N-[3-(triethoxysilyl)propyl]phthalamic acid; and bis-(2-hydroxyethyl)aminopropyltriethoxysilane. Exemplary of readily available materials containing amino group reactive functionalities, include, but are not limited to, para-aminophenyltriethoxysilane. Also derivatized polystyrenes and other such polymers are well known and readily available to those of skill in this art [e.g., the TENTAGEL® Resins are available with a multitude of functional groups, and are sold by Rapp Polymere, Tübingen, Germany; see, U.S. Patent No. 4,908,405 and U.S. Patent No. 5,292,814; see, also Butz *et al.* (1994) *Peptide Res.* 7:20-23; Kleine *et al.* (1994) *Immunobiol.* 190:53-66].

The data storage device with memory, however, generally should not or cannot be exposed to the reaction solution, and, thus, must be coated with at least a thin layer of a glass or ceramic or other protective coating that does not interfere with the operation of the device. These operations include electrical conduction across the device and transmission of remotely transmitted electromagnetic radiation by which data are written and read. It is such coating that may also serve as a matrix upon which the molecules or biological particles may be linked.

The data storage devices with memory may be coated either directly or following coating with a ceramic, glass or other material, may then be coated with agarose, which is heated, the devices are dipped into the agarose, and then cooled to about room temperature. The resulting glass, silica, agarose or other coated memory device, may be used as the matrix supports for chemical syntheses and reactions.

Conventional integrated circuit manufacturing and packaging methods include methods and means for encapsulating integrated circuits to protect the devices from the environment and to facilitate connection to external devices. Also, there are numerous descriptions for the

-50-

preparation of semiconductor devices and wires, particularly for use as sensors [see, e.g., U.S. Patent No. 4,933,285; see, also Cass, Ed. (1990) Biosensors A Practical Approach, IRL Press at Oxford University Press, Oxford; biosensors are chemosensors and can include a biological

5 detection system, generally biologically active substances, such as enzymes, antibodies, lectins and hormone receptors, which are immobilized on the surface of the sensor electrode or in a thin layer on the sensor electrode; biosensors are sensors that detect biological species], which measure electrochemical solution parameters, such as

10 pH. Despite differences in the components of biosensors and recording devices used herein, certain of the methods for coating electrodes and wires in the biosensor art may be adapted for use herein [see, e.g., U.S. Patent Nos. 5,342,772, 5,389,534, 5,384,028, 5,296,122, 5,334,880, 5,311,039, 4,777,019, 5,143,854, 5,200,051, 5,212,050,

15 5,310,686, 5,324,591; see, also Usmani et al., ed. (1994) Diagnostic Biosensor Polymers, ACS Symposium Series No. 556].

It is, however, emphasized that the combinations herein of matrix with memory are not sensors, which measure external parameters and can include electrodes that must be in contact with the solution such that

20 molecules in solution directly contact the electrode, and which measure solution parameters. Data regarding the combination, particularly the linked or associated biological particle or matrix is written into the memory, and thus records information about itself. Sensors monitor what is going outside of the device. The combinations herein of matrices

25 with memories can be enhanced by addition of sensor elements for the measurement of external conditions, information about the external conditions can be recorded into the combination's memory.

The combinations herein are matrix materials with recording devices that contain data storage units that include remotely

30 programmable memories; the recording devices used in solution must be

-51-

coated with a material that prevents contact between the recording device and the medium, such as the solution or air or gas [e.g., nitrogen or oxygen or CO<sub>2</sub>]. The information is introduced into the memory by addressing the memory to record information regarding molecules or biological particles linked thereto. Except in the reaction detecting [verifying] embodiment, in which the memory can be encoded upon reaction of a linked molecule or biological particle, solution parameters are not recorded in the memory.

In certain embodiments herein, the matrices with memories herein, however may be combined with devices or components or biosensors or other such sensor devices and used in connection therewith to monitor solution or external parameters. For example, the combination may be electronically or otherwise linked to a biosensor and information obtained by the biosensor can be encoded in memory, or the combination can transmit information to the biosensor or, when used internally in an animal, to monitor the location of a biosensor or to transmit information from the biosensor. For example, transponder memory devices exemplified herein, include circuitry for measuring and recording solution temperature. These transponders can be modified to read and record pH, instead of or in addition to temperature. Thus, during synthesis or other processing steps of linked or proximate molecules or biological particles, RF or other EM radiation will be used to encode information in the memory and at the same time pH and/or temperature in the external solution can be measured and recorded in the memory.

#### 25                   1.     **Natural matrix support materials**

Naturally-occurring supports include, but are not limited to agarose, other polysaccharides, collagen, celluloses and derivatives thereof, glass, silica, and alumina. Methods for isolation, modification and treatment to render them suitable for use as supports is well known to those of skill in this art [see, e.g., Hermanson et al. (1992) Immobilized Affinity Ligand

-52-

Techniques, Academic Press, Inc., San Diego]. Gels, such as agarose, can be readily adapted for use herein. Natural polymers such as polypeptides, proteins and carbohydrates; metalloids, such as silicon and germanium, that have semiconductive properties, as long as they do not  
5 interfere with operation of the data storage device may also be adapted for use herein. Also, metals such as platinum, gold, nickel, copper, zinc, tin, palladium, silver, again as long as the combination of the data storage device with memory, matrix support with molecule or biological particle does not interfere with operation of the device with memory, may be  
10 adapted for use herein. Other matrices of interest include oxides of the metal and metalloids such as Pt-PtO, Si-SiO, Au-AuO, TiO<sub>2</sub>, Cu-CuO, and the like. Also compound semiconductors, such as lithium niobate, gallium arsenide and indium-phosphide, and nickel-coated mica surfaces, as used in preparation of molecules for observation in an atomic force micro-  
15 scope [see, e.g., Ill et al. (1993) Biophys J. 64:919] may be used as matrices. Methods for preparation of such matrix materials are well known.

For example, U.S. Patent No. 4,175,183 describes a water insoluble hydroxyalkylated cross-linked regenerated cellulose and a method for its preparation. A method of preparing the product using near stoichio-  
20 metric proportions of reagents is described. Use of the product directly in gel chromatography and as an intermediate in the preparation of ion exchangers is also described.

## 2. Synthetic matrices

There are innumerable synthetic matrices and methods for their  
25 preparation known to those of skill in this art. Synthetic matrices are typically produced by polymerization of functional matrices, or copolymerization from two or more monomers of from a synthetic monomer and naturally occurring matrix monomer or polymer, such as agarose. Before such polymers solidify, they are contacted with the data  
30 storage device with memory, which can be cast into the material or

dipped into the material. Alternatively, after preparation of particles or larger synthetic matrices, the recording device containing the data storage unit(s) can be manually inserted into the matrix material. Again, such devices can be pre-coated with glass, ceramic, silica or other

5 suitable material.

Synthetic matrices include, but are not limited to: acrylamides, dextran-derivatives and dextran co-polymers, agarose-polyacrylamide blends, other polymers and co-polymers with various functional groups, methacrylate derivatives and co-polymers, polystyrene and polystyrene

10 copolymers [see, e.g., Merrifield (1964) Biochemistry 3:1385-1390; Berg et al. (1990) in Innovation Perspect. Solid Phase Synth. Collect. Pap., Int. Symp., 1st, Epton, Roger (Ed), pp. 453-459; Berg et al. (1989) in Pept., Proc. Eur. Pept. Symp., 20th, Jung, G. et al. (Eds), pp. 196-198; Berg et al. (1989) J. Am. Chem. Soc. 111:8024-8026; Kent et al. (1979) Isr. J. Chem. 17:243-247; Kent et al. (1978) J. Org. Chem. 43:2845-2852; Mitchell et al. (1976) Tetrahedron Lett. 42:3795-3798; U.S. Patent No. 4,507,230; U.S. Patent No. 4,006,117; and U.S. Patent No. 5,389,449]. Methods for preparation of such matrices are well-known to those of skill in this art.

20 Synthetic matrices include those made from polymers and co-polymers such as polyvinylalcohols, acrylates and acrylic acids such as polyethylene-co-acrylic acid, polyethylene-co-methacrylic acid, polyethylene-co-ethylacrylate, polyethylene-co-methyl acrylate, polypropylene-co-acrylic acid, polypropylene-co-methyl-acrylic acid, polypropylene-co-ethylacrylate, polypropylene-co-methyl acrylate, polyethylene-co-vinyl acetate,

25 late, polypropylene-co-vinyl acetate, and those containing acid anhydride groups such as polyethylene-co-maleic anhydride, polypropylene-co-maleic anhydride and the like. Liposomes have also been used as solid supports for affinity purifications [Powell et al. (1989) Biotechnol. Bioeng.

30 33:173].

For example, U.S. Patent No. 5,403,750, describes the preparation of polyurethane-based polymers. U.S. Pat. No. 4,241,537 describes a plant growth medium containing a hydrophilic polyurethane gel composition prepared from chain-extended polyols; random copolymerization is preferred with up to 50% propylene oxide units so that the prepolymer will be a liquid at room temperature. U.S. Pat. No. 3,939,123 describes lightly crosslinked polyurethane polymers of isocyanate terminated prepolymers containing poly(ethyleneoxy) glycols with up to 35% of a poly(propyleneoxy) glycol or a poly(butyleneoxy) glycol. In producing these polymers, an organic polyamine is used as a crosslinking agent. Other matrices and preparation thereof are described in U.S. Patent Nos. 4,177,038, 4,175,183, 4,439,585, 4,485,227, 4,569,981, 5,092,992, 5,334,640, 5,328,603

U.S. Patent No. 4,162,355 describes a polymer suitable for use in affinity chromatography, which is a polymer of an aminimide and a vinyl compound having at least one pendant halo-methyl group. An amine ligand, which affords sites for binding in affinity chromatography is coupled to the polymer by reaction with a portion of the pendant halo-methyl groups and the remainder of the pendant halo-methyl groups are reacted with an amine containing a pendant hydrophilic group. A method of coating a substrate with this polymer is also described. An exemplary aminimide is 1,1-dimethyl-1-(2-hydroxyoctyl)amine methacrylimide and vinyl compound is a chloromethyl styrene.

U.S. Patent No. 4,171,412 describes specific matrices based on hydrophilic polymeric gels, preferably of a macroporous character, which carry covalently bonded D-amino acids or peptides that contain D-amino acid units. The basic support is prepared by copolymerization of hydroxyalkyl esters or hydroxyalkylamides of acrylic and methacrylic acid with crosslinking acrylate or methacrylate comonomers are modified by the reaction with diamines, aminoacids or dicarboxylic acids and the



-55-

resulting carboxyterminal or aminoterminal groups are condensed with D-analogs of aminoacids or peptides. The peptide containing D-aminoacids also can be synthesized stepwise on the surface of the carrier.

U.S. Patent No. 4,178,439 describes a cationic ion exchanger and  
5 a method for preparation thereof. U.S. Patent No. 4,180,524 describes chemical syntheses on a silica support.

Immobilized Artificial Membranes [IAMs; see, e.g., U.S. Patent Nos. 4,931,498 and 4,927,879] may also be used. IAMs mimic cell membrane environments and may be used to bind molecules that  
10 preferentially associate with cell membranes [see, e.g., Pidgeon et al. (1990) Enzyme Microb. Technol. 12:149].

### 3. Immobilization and activation

Numerous methods have been developed for the immobilization of proteins and other biomolecules onto solid or liquid supports [see, e.g.,  
15 Mosbach (1976) Methods in Enzymology 44; Weetall (1975) Immobilized Enzymes, Antigens, Antibodies, and Peptides; and Kennedy et al. (1983) Solid Phase Biochemistry, Analytical and Synthetic Aspects, Scouten, ed., pp. 253-391; see, generally, Affinity Techniques. Enzyme Purification: Part B. Methods in Enzymology, Vol. 34, ed. W. B. Jakoby,  
20 M. Wilchek, Acad. Press, N.Y. (1974); Immobilized Biochemicals and Affinity Chromatography, Advances in Experimental Medicine and Biology, vol. 42, ed. R. Dunlap, Plenum Press, N.Y. (1974)].

Among the most commonly used methods are absorption and ad-  
sorption or covalent binding to the support, either directly or via a linker,  
25 such as the numerous disulfide linkages, thioether bonds, hindered disulfide bonds, and covalent bonds between free reactive groups, such as amine and thiol groups, known to those of skill in art [see, e.g., the PIERCE CATALOG, ImmunoTechnology Catalog & Handbook, 1992-1993, which describes the preparation of and use of such reagents and  
30 provides a commercial source for such reagents; and Wong (1993)

Chemistry of Protein Conjugation and Cross Linking, CRC Press; see, also DeWitt et al. (1993) Proc. Natl. Acad. Sci. U.S.A. 90:6909; Zuckermann et al. (1992) J. Am. Chem. Soc. 114:10646; Kurth et al. (1994) J. Am. Chem. Soc. 116:2661; Ellman et al. (1994) Proc. Natl. Acad. Sci. U.S.A. 5 91:4708; Sucholeiki (1994) Tetrahedron Ltrrs. 35:7307; and Su-Sun Wang (1976) J. Org. Chem. 41:3258; Padwa et al. (1971) J. Org. Chem. 41:3550 and Vedejs et al. (1984) J. Org. Chem. 49:575, which describe photosensitive linkers]

To effect immobilization, a solution of the protein or other  
10 biomolecule is contacted with a support material such as alumina, carbon, an ion-exchange resin, cellulose, glass or a ceramic. Fluorocarbon polymers have been used as supports to which biomolecules have been attached by adsorption [see, U.S. Pat. No. 3,843,443; Published International PCT Application WO/86 03840].

15 A large variety of methods are known for attaching biological molecules, including proteins and nucleic acids, molecules to solid supports [see, e.g., U.S. Patent No. 5451683]. For example, U.S. Pat. No. 4,681,870 describes a method for introducing free amino or carboxyl groups onto a silica matrix. These groups may subsequently be  
20 covalently linked to other groups, such as a protein or other anti-ligand, in the presence of a carbodiimide. Alternatively, a silica matrix may be activated by treatment with a cyanogen halide under alkaline conditions. The anti-ligand is covalently attached to the surface upon addition to the activated surface. Another method involves modification of a polymer  
25 surface through the successive application of multiple layers of biotin, avidin and extenders [see, e.g., U.S. Patent No. 4,282,287]; other methods involve photoactivation in which a polypeptide chain is attached to a solid substrate by incorporating a light-sensitive unnatural amino acid group into the polypeptide chain and exposing the product to low-energy  
30 ultraviolet light [see, e.g., U.S. Patent No. 4,762,881]. Oligonucleotides

-57-

have also been attached using a photochemically active reagents, such as a psoralen compound, and a coupling agent, which attaches the photoreagent to the substrate [see, e.g., U.S. Patent No. 4,542,102 and U.S. Patent No. 4,562,157]. Photoactivation of the photoreagent binds a

5 nucleic acid molecule to the substrate to give a surface-bound probe.

Covalent binding of the protein or other biomolecule or organic molecule or biological particle to chemically activated solid matrix supports such as glass, synthetic polymers, and cross-linked polysaccharides is a more frequently used immobilization technique. The

10 molecule or biological particle may be directly linked to the matrix support or linked via linker, such as a metal [see, e.g., U.S. Patent No. 4,179,402; and Smith et al. (1992) Methods: A Companion to Methods in Enz. 4:73-78]. An example of this method is the cyanogen bromide activation of polysaccharide supports, such as agarose. The use of

15 perfluorocarbon polymer-based supports for enzyme immobilization and affinity chromatography is described in U.S. Pat. No. 4,885,250]. In this method the biomolecule is first modified by reaction with a perfluoroalkylating agent such as perfluorooctylpropylisocyanate described in U.S. Pat. No. 4,954,444. Then, the modified protein is adsorbed onto the fluoro-

20 carbon support to effect immobilization.

The activation and use of matrices are well known and may be effected by any such known methods [see, e.g., Hermanson et al. (1992) Immobilized Affinity Ligand Techniques, Academic Press, Inc., San Diego]. For example, the coupling of the amino acids may be

25 accomplished by techniques familiar to those in the art and provided, for example, in Stewart and Young, 1984, Solid Phase Synthesis, Second Edition, Pierce Chemical Co., Rockford.

-58-

Molecules may also be attached to matrices through kinetically inert metal ion linkages, such as Co(III), using, for example, native metal binding sites on the molecules, such as IgG binding sequences, or genetically modified proteins that bind metal ions [see, e.g., Smith et al. (1992) Methods: A Companion to Methods in Enzymology 4, 73 (1992); 5 Ill et al. (1993) Biophys J. 64:919; Loetscher et al. (1992) J. Chromatography 595:113-199; U.S. Patent No. 5,443,816; Hale (1995) Analytical Biochem. 231:46-49 ].

Other suitable methods for linking molecules and biological 10 particles to solid supports are well known to those of skill in this art [see, e.g., U.S. Patent No. 5,416,193]. These linkers include linkers that are suitable for chemically linking molecules, such as proteins and nucleic acid, to supports include, but are not limited to, disulfide bonds, thioether bonds, hindered disulfide bonds, and covalent bonds between free 15 reactive groups, such as amine and thiol groups. These bonds can be produced using heterobifunctional reagents to produce reactive thiol groups on one or both of the moieties and then reacting the thiol groups on one moiety with reactive thiol groups or amine groups to which reactive maleimido groups or thiol groups can be attached on the other. 20 Other linkers include, acid cleavable linkers, such as bismaleimideoxy propane, acid labile-transferrin conjugates and adipic acid dihydrazide, that would be cleaved in more acidic intracellular compartments; cross linkers that are cleaved upon exposure to UV or visible light and linkers, such as the various domains, such as C<sub>H</sub>1, C<sub>H</sub>2, and C<sub>H</sub>3, from the 25 constant region of human IgG<sub>1</sub> (see, Batra et al. (1993) Molecular Immunol. 30:379-386).

Presently preferred linkages are direct linkages effected by adsorbing the molecule or biological particle to the surface of the matrix. Other preferred linkages are photocleavable linkages that can be activated 30 by exposure to light [see, e.g., Baldwin et al. (1995) J. Am. Chem. Soc.

117:5588; Goldmacher *et al.* (1992) *Bioconj. Chem.* **3**:104-107, which linkers are herein incorporated by reference]. The photocleavable linker is selected such that the cleaving wavelength that does not damage linked moieties. Photocleavable linkers are linkers that are cleaved upon

5 exposure to light [see, *e.g.*, Hazum *et al.* (1981) in *Pept., Proc. Eur. Pept. Symp.*, 16th, Brunfeldt, K (Ed), pp. 105-110, which describes the use of a nitrobenzyl group as a photocleavable protective group for cysteine; Yen *et al.* (1989) *Makromol. Chem* **190**:69-82, which describes water

10 soluble photocleavable copolymers, including hydroxypropylmethacryl- amide copolymer, glycine copolymer, fluorescein copolymer and methylrhodamine copolymer; Goldmacher *et al.* (1992) *Bioconj. Chem.* **3**:104-107, which describes a cross-linker and reagent that undergoes

15 photolytic degradation upon exposure to near UV light (350 nm); and Senter *et al.* (1985) *Photochem. Photobiol* **42**:231-237, which describes nitrobenzyloxycarbonyl chloride cross linking reagents that produce

20 photocleavable linkages]. Other linkers include fluoride labile linkers [see, *e.g.*, Rodolph *et al.* (1995) *J. Am. Chem. Soc.* **117**:5712], and acid labile linkers [see, *e.g.*, Kick *et al.* (1995) *J. Med. Chem.* **38**:1427]. The selected linker will depend upon the particular application and, if needed,

#### B. Data storage units with memory

Any remotely programmable data storage device that can be linked to or used in proximity to the solid supports and molecules and biological particles as described herein is intended for use herein. Preferred devices

25 are rapidly and readily programmable using penetrating electromagnetic radiation, such as radio frequency or visible light lasers, operate with relatively low power, have fast access [preferably 1 sec or less, more preferably  $10^2$ - $10^3$  sec], and are remotely programmable so that information can be stored or programmed and later retrieved from a

30 distance, as permitted by the form of the electromagnetic signal used for

-60-

transmission. Presently preferred devices are on the order of 1-10 mm in the largest dimension and are remotely programmable using RF or radar.

Recording devices may be active, which contain a power source, such as a battery, and passive, which does not include a power source.

5 In a passive device, which has no independent power source, the transmitter/receiver system, which transfers the data between the recording device and a host computer and which is preferably integrated on the same substrate as the memory, also supplies the power to program and retrieve the data stored in the memory. This is effected by  
10 integrating a rectifier circuit onto the substrate to convert the received signal into an operating voltage.

Alternatively, an active device can include a battery [see, e.g., U.S. Patent No. 5,442,940, U.S. Patent No. 5,350,645, U.S. Patent No. 5,212,315, U.S. Patent No. 5,029,214, U.S. Patent No. 4,960,983] to  
15 supply the power to provide an operating voltage to the memory device. When a battery is used the memory can be an EEPROM, a DRAM, or other erasable memory requiring continuous power to retain information. It may be desirable to combine the antenna/rectifier circuit combination with a battery to create a passive/active device, with the voltages  
20 supplied by each source supplementing each other. For example, the transmitted signal could provide the voltage for writing and reading, while the battery, in addition to supplementing this voltage, provides a refresh voltage for a DRAM memory so that data is retained when the transmitted signal is removed.

25 The remotely programmable device can be programmed sequentially to be uniquely identifiable during and after stepwise synthesis of macromolecules or before, or during, or after selection of screened molecules. In certain embodiments herein, the data storage units are information carriers in which the functions of writing data and reading the  
30 recorded data are empowered by an electromagnetic signal generated and

-61-

modulated by a remote host controller. Thus, the data storage devices are inactive, except when exposed to the appropriate electromagnetic signal. In an alternative embodiment, the devices may be optically or magnetically programmable read/write devices.

**5 Electromagnetically programmable devices**

The programmable devices intended for use herein, include any device that can record or store data. The preferred device will be remotely programmable and will be small, typically on the order of 10-20 mm<sup>3</sup> [or 10-20 mm in its largest dimension] or, preferably smaller.

**10** Any means for remote programming and data storage, including semiconductors and optical storage media are intended for use herein.

Also intended for use herein, are commercially available precoded devices, such as identification and tracking devices for animals and merchandise, such those used with and as security systems [see, e.g.,  
**15** U.S. Patent Nos. 4,652,528, 5,044,623, 5,099,226, 5,218,343, 5,323,704, 4,333,072, 4,321,069, 4,318,658, 5,121,748, 5,214,409, 5,235,326, 5,257,011 and 5,266,926], and devices used to tag animals. These devices may also be programmable using an RF signal. These device can be modified, such as by folding it, to change geometry to  
**20** render them more suitable for use in the methods herein. Of particular interest herein are devices sold by BioMedic Data Systems, Inc, NJ [see, e.g., the IPTT-100 purchased from BioMedic Data Systems, Inc., Maywood, NJ; see, also U.S. Patent Nos. 5,422, 636, 5,420,579, 5,262,772, 5,252,962, 5,250,962, and see, also, U.S. application Serial  
**25** No. 08/322,644, filed October 13, 1994]. ID tags available from IDTAG™ Inc, particularly the IDT150 read/write transponder [ITDAG™ Ltd. Bracknell, Berks RG12 3XQ, UK, fabricated using standard procedures and the method for coil winding, bonding and packaging described in International PCT application Nos. WO95/33246, WO95/16270,  
**30** WO94/24642, WO93/12513, WO92/15105, WO91/16718; see, also

-62-

U.S. Patent Nos. 5,223,851 and 5,281,855] are also preferred herein. The IDT150 is a CMOS device that provides a kilobit of EEROM. This transponder also includes a 32 bit fixed code serial number that uniquely identifies each chip. The IDTAG™ transponder transmits data to a

5 transceiver system by amplitude modulating its coil and generating an EM field. It receives data and commands from a transceiver by demodulating the field received by the coil and decoding the commands. The transponder derives its power source from a frequency emitted in the signal from the reader, to which the transponder emits a response. A

10 smaller version [that has 16 bit EEROM] and is about 11 mm x 4 mm x 3 mm of this transponder is also among preferred devices. These transponders are packaged in glass or polystyrene or other such material.

In a preferred embodiment herein, the data storage unit includes a semiconductor chip with integrated circuits formed thereon including a

15 memory and its supporting circuitry. These devices can be written to and interrogated from a distance. A radio frequency transmitter/receiver system supplies power to program and retrieve data. In particular, the data storage unit preferably includes a programmable read only semiconductor memory [PROM], preferably a non-volatile memory or other

20 memory that can store data for future retrieval, that will have information describing or identifying the molecules or biological particles linked to or in proximity to the matrix. This information either identifies the molecule or biological particles including a phage and viral particles, bacteria, cells and fragments thereof, provides a history of the synthesis of the

25 molecule, or provides information, such as a batch number, quality control data, reaction number, and/or identity of the linked entity. The memory is programmed, before, during or, preferably, after, each step of synthesis and can thereafter be read, thereby identifying the molecule or its components and order of addition, or process of synthesis.



-63-

While many well known read only memory devices use fuse structures that are selectively "blown" to store data points, with a fuse located at each possible data address in an array, among the devices of interest herein are those that rely on antifuse programming technology, in  
5 which short circuits are selectively created through an insulating layer separating word and bit lines in an array. Due to the relatively low level of voltage supplied by the transmitted signal when the memory device is passive, antifuse memories are readily used because of the lower voltage requirements for writing.

10 Thus, suitable memory devices, are about 1-20 mm in the smallest dimension [or smaller], are rapidly programmable [1 sec, preferably 1 msec or less], can be interrogated from a distance [distances of about a centimeter up to about an inch are presently preferred], and are  
programmable using electromagnetic radiation, preferably frequencies,  
15 such as those within the radio frequency range, that do not alter the assessed activities and physical properties of the molecules and biological particles of interest.

Devices that rely on other programmable volatile memories are also intended for use herein. For example, a battery may be used as to supply  
20 the power to provide an operating voltage to the memory device. When a battery is used the memory can be an EEPROM, a DRAM, or other erasable memory requiring continuous power to retain information. It may be advantageous to combine the antenna/rectifier circuitry with a battery to create a passive/active device, in which the voltages supplied by each  
25 source supplement each other. For example, the transmitted signal could provide the voltage for writing and reading, while the battery, in addition to supplementing this write/read voltage, provides a refresh voltage for a DRAM memory so that data is retained when the transmitted signal is removed.

-64-

### Antifuses

An antifuse contains a layer of antifuse material sandwiched between two conductive electrodes. The antifuse device is initially an open circuited device in its unprogrammed state and can be irreversibly  
5 converted into an essentially short circuited device by the application of a programming voltage across the two electrodes to disrupt the antifuse material and create a low resistance current path between the two electrodes.

An exemplary antifuse structure for use herein is formed by  
10 defining a word line of heavily N-doped polysilicon on an insulating substrate, depositing an antifuse layer of lightly N-doped semiconductor over the polysilicon, and defining a metal address [or bit] line upon and in electrical contact with the antifuse layer. The semiconductor material used for the antifuse layer is typically selected from among silicon,  
15 germanium, carbon and alpha-tin. The properties of the semiconductor material are such that the material is essentially non-conductive as long as the voltage across it does not exceed a threshold level. Once the threshold voltage is exceeded, a conductive filament is formed through the semiconductor so that the resistance between the metal and  
20 polysilicon lines at the points at which they cross irreversibly switches from a high resistance state to a relatively low resistance state.

To program or change the resistance of the antifuse from a very high level [greater than 100,000,000 ohms] to a low level [less than 1000 ohms], a voltage of sufficiently high electrical field strength is  
25 placed across the antifuse film to create a short circuit. The voltage level required to induce breakdown is determined by the level of dopant in the antifuse layer. As breakdown occurs electrical current will flow through one small region of the film. The current is limited by the resistance of the filament itself as well as any series resistance of conductive layers or  
30 logic devices [transistors] in series with the antifuse.

-65-

Examples of the antifuse and its use as a memory cell within a Read-Only Memory are discussed in Roesner *et al.*, "Apparatus and Method of Use of Radio frequency Identification Tags", U.S. application Serial No. 08/379,923, filed January 27, 1995, Roesner, "Method of  
5 Fabricating a High Density Programmable Read-Only Memory", U.S. Pat. No. 4,796,074 (1989) and Roesner, "Electrically Programmable Read-Only Memory Stacked above a Semiconductor Substrate", U.S. Pat. No. 4,442,507 (1984). A preferred antifuse is described in U.S. Patent No. 5,095,362. " Method for reducing resistance for programmed  
10 antifuse" (1992) [see, also U.S. Patent No. 5,412,593 and 5,384,481].

U.S. Patent No. 5,095,362 provides a method for fabricating a layer of programmable material within an antifuse that exhibits relatively lower than normal resistance in its programmed state and also provides a semiconductor device containing an antifuse film of the type composed of  
15 semiconductor material having a first electrical state that is characterized by high electrical resistivity and a second electrical state that is characterized by low electrical resistivity.

The means for selectively decreasing resistivity includes nonactivated conductive dopants that are ion implanted within the  
20 otherwise highly resistive semiconductor material. The dopants as implanted are in a nonactivated state so that the dopants do not enhance the conduction of carriers in the film. Once activated, the dopants enhance the conduction of carriers in the film. Activation of the dopants occurs upon application of a threshold voltage across a predetermined  
25 and selected portion of the material in which the dopants are disposed. The selected portion is defined by the crossover point of selected word and bit [or address] lines. The dopants are N-type, selected from among antimony, phosphorous, arsenic, and others to provide additional charge carriers. The implant dosage is used to determine the threshold voltage  
30 level that will be required to induce formation of the conductive filament.

-66-

P-type dopants, such as boron, may also be used to affect a change in programming voltage.

**A preferred recording device with non-volatile, such as anti-fuse-based, memory**

- 5 Referring to Figure 5, which depicts a preferred embodiment, a recording device containing a non-volatile electrically-programmable read-only memory [ROM] 102 that utilizes antifuse technology [or EEPROM or other suitable memory] is combined on a single substrate 100 with a thin-film planar antenna 110 for receiving/transmitting an RF signal 104, a
- 10 rectifier 112 for deriving a voltage from a received radio frequency [RF] signal, an analog-to-digital converter [ADC] 114 for converting the voltage into a digital signal for storage of data in the memory, and a digital-to-analog converter [DAC] 116 for converting the digital data into a voltage signal for transmission back to the host computer is provided.
- 15 A single substrate 100 is preferred to provide the smallest possible chip, and to facilitate encapsulation of the chip with a protective, polymer shell [or shell + matrix or matrix material] 90. Shell 90 must be non-reactive with and impervious to the various processes that the recording device is being used to track in order to assure the integrity of the memory device
- 20 components on the chip. Materials for the shell include any such materials that are known to those of skill in the art [see, e.g., Hiroshi et al., eds. (1995) Polymeric Materials for Microelectronic Applications: Science and Technology, ACS Symposium Series No. 579], including glasses, ceramics, plastics and other inert coatings.
- 25 Based on current semiconductor integrated circuit fabrication process capabilities, in a preferred embodiment the finished chip on which all of the listed components are integrated is on the order of 1 mm x 1 mm [~ 40 mils x 40 mils], with a memory capacity of about 1024 bits, but can have greater or lesser capacity as required or desired. Greater
- 30 memory capacity, where needed, and smaller chips, however, will be

-67-

preferred. The chip may be larger to accommodate more memory if desired, or may be smaller as design rules permit smaller transistors and higher device densities, i.e., greater memory capacity.

The antifuse ROM structure described herein, and the method for  
5 fabricating the same, are based upon the teachings of United States  
Patent No. 4,424,579, issued January 3, 1984, No. 4,442,507, issued  
April 10, 1984, No. 4,796,074, issued January 3, 1989, and No.  
5,095,362, issued March 10, 1992, all of Roesner, No. 4,598,386,  
issued July 1, 1986, of Roesner et al., and No. 5,148,256, issued  
10 September 15, 1992 and No. 5,296,722, issued March 22, 1994, both  
of Potash, et al., and also U.S. application Serial No. 08/379,923, filed  
January 27, 1995, to Roesner et al., all of which are incorporated herein  
by reference.

In an antifuse-type memory device, the individual memory cells are  
15 arranged in arrays of orthogonal conductive word and bit lines to obtain  
the smallest possible memory array size. For example, for 1024 bits of  
memory, there are 32 word lines and 32 bit lines for a square array.  
Memories with greater capacity may also be used. Schottky diodes are  
formed generally corresponding to the points at which the word and bit  
20 lines cross. The word and bit lines are separated by an undoped or  
lightly-doped semiconductor layer with interstitial doping. The  
semiconductor layer may also be amorphous silicon with implanted  
dopants in a nonactivated state. Each of these crossover points is a  
memory cell and is the equivalent of a programmable switch in series  
25 with a Schottky diode. Data are stored by the switch being ON or OFF.  
As fabricated, an antifuse memory device has all of its switches in the  
OFF state. A switch is turned on by applying a voltage in excess of a  
pre-determined threshold voltage to one of the word lines while setting a  
selected bit line to a low logic level. The threshold voltage is determined  
30 by the impedance of the semiconductor layer, i.e., its doping level.

-68-

According to the process for fabricating the antifuse memory of the preferred embodiment, the impedance can be less than 200 ohms with a threshold voltage for programming as low as 3 volts. Since in the embodiment described herein the programming voltage is provided solely  
5 by the rectified RF signal, a low threshold is preferred. Application of voltage exceeding the threshold activates the interstitial dopant in the semiconducting film at the point corresponding to the cross-over between the two lines, causing a short between the word and bit lines and irreversibly turning on that particular switch or memory cell. Address  
10 decoders, as are known in the art, are used to selectively address the word and bit lines for purposes of both writing information to and reading stored information from the memory array. [See, e.g., U.S. Patent No. 5,033,623, 5,099,226, 5,105,190, 5,218,343, 5,323,704]. Exemplary means for decoding information to be stored in memory and to be read  
15 from memory are provided in Patents No. 4,442,507 and No. 4,598,386.

Information to be written into the memory need not be detailed since the data stored in the memory is primarily acting as an identification marker that is traceable to a more detailed record stored in the host computer memory 120, independent of the memory associated with the  
20 matrix support or tagged molecule or biological particle. In this manner, the RF signal from transmitter 80 that is used to provide the power and the signal to the matrix particle memory need only address a single memory cell to indicate that a nascent oligomer linked to or in proximity to the memory device has been subjected to a given process step or to  
25 identify a molecule or biological particle. In other words, a conventional "push-pull" type of address decoder, where only one bit line and one word line are driven high and low, respectively, at any given time, may be used. Thus, a sophisticated memory addressing system need not be provided on the matrix particle memory chip, and shift registers may be  
30 used to control memory addressing. Alternatively, a microprocessor

-69-

which is mask-programmed during the fabrication process for controlling an address bus which connects the ADC 114 and the DAC 116 to the memory array may also be built onto the same substrate on which the memory and other components are integrated. Other integrated means  
5 for selectively addressing locations within the memory are known and will be apparent to the practitioner skilled in the art.

As described above, antifuse memories are well known in the art. These memories include structures in which the word and bit lines may both be made of either N+ polysilicon or metal [aluminum or aluminum-  
10 silicon], separated by silicon dioxide ( $\text{SiO}_2$ ), silicon nitride ( $\text{Si}_3\text{N}_4$ ), combinations thereof, or amorphous silicon alone or in combination with  $\text{SiO}_2$  and/or  $\text{Si}_3\text{N}_4$ . In each case, a short circuit is created at locations in the antifuse material corresponding to the crossover location of selected word and bit lines by applying a voltage in excess of a pre-determined  
15 threshold voltage.

Examples of alternate means for forming an antifuse memory are provided in the following U.S. Patents: No. 5,248,632, issued September 28, 1993, of Tung et al.; No. 5,250,459, issued October 5, 1993, of Lee, No. 5,282,158, issued January 25, 1994, of Lee; No.  
20 5,290,734, issued March 1, 1994, of Boardman, et al.; No. 5,300,456, issued April 5, 1994, of Tigelaar et al.; No. 5,311,039, issued May 10, 1994, of Kimura, et al.; No. 5,316,971, issued May 31, 1994, of Chiang et al.; No. 5,322,812, issued June 21, 1994, of Dixit, et al.; No. 5,334,880, issued August 2, 1994, of Abadeer, et al., and others.

25 Generally for use in the methods herein, non-volatility of the memory or the ability to lock or prevent erasure is preferred since power is applied to the chip only when it is subjected to the RF or other transmission signal for reading or reading and writing. Further considerations are the voltage levels required for writing into memory, since the  
30 threshold voltage must be less than the maximum voltage of the rectified

-70-

RF signal in order to assure that sufficient voltage is always available during the writing process. The write voltage may be enhanced by supplementing the RF-supplied voltage with optically-generated voltage, such as a photocell. Photocells on semiconductor substrates are well known in the art and could be easily integrated onto the chip. A laser or other light source could be readily included in the write apparatus to illuminate the chip coincident with transmission of the RF write signal. Similarly, other forms of electromagnetic radiation may be used to provide additional power, if needed.

10 Although antifuse memories are not designed to be erasable, it may be desirable to re-use the devices if the memory becomes full. In such instances, conventional electrically programmable erasable read only memories [EEPROMs] may be used instead. Since EEPROMs require higher write voltage levels, it may be desirable to supplement the RF-supplied voltage as described above. In EEPROMs, stored data can be 15 erased by exposing the device to UV light.

Signal rectifier 112 may be one or more Schottky diode(s), making it readily incorporated into the fabrication process used for the memory array. Other means for signal rectification may be used as are known.

20 The ADC 114 and DAC 116 are well-known devices and are readily integrated onto the substrate 100 using the fabrication process described in the references for the memory array. Radio frequency modulation techniques, which are known in the art, for example, pulse code modulation, may be adapted to permit direct digital transmission, in 25 which case the ADC and DAC may not be required.

Antenna 110 is formed during the fabrication process using conventional photolithographic techniques to provide one or more metal structures, such as aluminum, to receive a pre-determined wavelength RF transmission. The antenna may be a simple straight line half-wave 30 antenna which is created by patterning a structure during the second



-71-

metal process steps so that the structure has a length equal to one-half of the wavelength of the selected RF transmission frequency in free space. Another option for formation of the antenna is as a small loop, either on a dedicated portion of the chip, or encircling the other

**5** components of the chip, also formed during the second metal step of the fabrication process. It is noted that, in a typical semiconductor fabrication process, such as would be compatible with the preferred antifuse memory, the first and second metal steps include depositing a layer of aluminum, then patterning the aluminum photolithographically

**10** followed by a plasma etch to define the desired features. Except where vias are formed, the two metal layers are separated by a dielectric film. Dipole antennas may be formed by patterning the second metal in a similar manner, with the dimensions of the antenna being selected for the appropriate RF frequency. The two metal layers may also be used to

**15** form a microstrip antenna structure by selecting the dielectric film between the metal layers such that it has a dielectric constant and thickness appropriate so that the microstrip is resonant at one-half of the RF wavelength. [The first metal layer provides the ground plane.] The metal structures, which may be square patches, circles, lines, or other

**20** geometries, are defined photolithographically during the normal masking steps of the first and second metal processes. Other antenna structures which can be configured as a thin film device for integration onto a common substrate with the memory structure and other components may be used and will be apparent to those skilled in the art. Similarly, a

**25** resonant circuit [inductor-capacitor] can be readily integrated onto the chip, with the resonant circuit being tuned to the RF carrier signal of the transmitter.

Frequency tuning of either an antenna or resonant circuit can provide additional coding capability. For example, a first group of

**30** memory devices can be tuned to receive a carrier wave of a first RF

-72-

frequency, e.g.,  $f_1$ , and a second group could be tuned to receive a second frequency  $f_2$ , and so on. The separate carrier frequencies could provide additional means for tracking or providing information to the devices, even if the groups become intermixed.

5           The RF antenna may, in an alternate embodiment, be formed external to the semiconductor substrate. In this configuration, a separate conductive wire, which acts as an antenna, will be attached to a bond pad formed on the chip using methods known to those skilled in the art. The wire will then be stabilized when the chip is encased in the protective  
10 shell, so that the antenna extends at some angle to the chip.

          Also, as an alternative to signal transmission via RF, the antifuse or other semiconductor memory and supporting circuitry can receive the addressing commands and device power by optical transmission. In this embodiment, the RF antenna 110 would be replaced by a photocell that  
15 generates sufficient write voltage to exceed the threshold voltage. For the addressing commands, the RF transmitter 80 is replaced by a light source, and the commands may be transmitted digitally by pulsing the optical transmitter, which can be a laser, flash lamp or other high intensity light source. It is noted that the light intensity must be  
20 sufficient to generate adequate voltage, either singly or in conjunction with a second power generating device, in the photocell to write into memory, but not so high that it damages the metal interconnect on the chip. With digital data transmission analog-to-digital and digital-to-analog conversion circuitry can be eliminated.

25           The operation of programming the memory to record the process steps to which the linked or adjacent matrix particle or support and linked or proximate molecule or biological particle is exposed involves placing the memory device reasonably close [a distance on the order of about 1 inch [25.4 mm] is presently contemplated, but longer distances should be  
30 possible and shorter distances are also contemplated [suitable distances

can be determined empirically] to RF transmitter 80. The RF transmitter 80 emits a carrier wave modulated by a signal generated by host computer 122 using conventional RF technology. The carrier wave itself can provide the power to generate the programming voltage and the operating voltage for the various devices via the rectifier, while the modulation signal provides the address instructions. As stated previously, since the memory only has to be "tagged" to record the exposure of the proximate or linked molecule or biological particle to a given process, the address signal only has to carry information to turn on a single memory location, while the host computer 122 stores into memory 120 the information linking the process information with the single memory location that was "tagged" to record exposure to the process step. Referring to Figure 1, in which chemical building blocks A, C, and E are added to a molecule linked to a matrix with memory, and to Figure 6, an illustrative example of how information is written onto a particle is provided in Table 1.

TABLE 1

|    | <u>PROCESS STEP</u> | <u>X-REGISTER ADDRESS</u> | <u>Y-REGISTER ADDRESS</u> |
|----|---------------------|---------------------------|---------------------------|
| 20 | A                   | 1                         | 8                         |
|    | C                   | 2                         | 4                         |
|    | E                   | 3                         | 2                         |

For the step in which A is added, the address signal would increment the x-register 124 one location and increment the y-register 126 eight locations, and then apply the programming voltage. The activation of this switch is indicated by an "A" at the selected address, although the actual value stored will be a binary "1", indicating ON. [As described, for example, in U.S. Patent No. 4,424,579; the manner in which the programming voltage is applied depends on whether the decoders have depletion or enhancement transistors.] The host computer 122 would write into its memory 120 that for process A, the x-

-74-

,y- address is 1,8. Upon removal of the RF signal after recording process A, the voltage is removed and the registers would reset to 0. For the step in which C is added, the address signal would increment the x-register 124 two locations and the y-register 126 four locations, then  
5 apply the programming voltage, as indicated by the letter "C". The host computer 120 would similarly record in memory that an indication of exposure to process C would be found at x-,y- address 2,4. Again, upon removal of the RF signal, the registers reset to 0 so that when the matrix particle's memory is again exposed to RF following addition of block E,  
10 the registers increment 3 and 2 locations, respectively, and the programming voltage is applied to turn on the switch, indicated by "E". Desirably all processing steps are automated.

After processing is completed, to read the information that has been recorded in the memory of the data storage unit, the host computer  
15 122 will inquire into the identity of the particle by generating a command signal to the registers to select the appropriate address locations to determine whether the switch is on or off. If the switch is on, i.e., a voltage drop occurs at that point, the computer will create a record that the particle received a particular process step. Alternatively, the host  
20 computer can generate an inquiry signal to sequentially look at all memory locations to determine which switches have been turned on, recording all locations at which voltage drops occurred. The computer will then compare the "on" locations to the process steps stored in its memory to identify the steps through which the subject particle was  
25 processed.

If desired, individual particles can be identified by reserving certain memory locations for identification only, for example, the first two rows of the x-register. In this case, particles will be passed separately through the RF signal while the x-register is incremented to turn on switches at  
30 address locations 0,0, 1,0, 2,0, etc. With individual identification, the

-75-

host computer 122 can first generate a signal to query a matrix particle memory to determine its identity, then write the information with regard to the process performed, saving the process and particle information in the host computer memory 120.

- 5           Ideally, the tagging of particles which are exposed to a particular process would be performed in the process vessel containing all of the particles. The presence, however, of a large number of particles may result in interference or result in an inability to generate a sufficiently high voltage for programming all of the particles simultaneously. This might
- 10 be remedied by providing an exposure of prolonged duration, e.g., several minutes, while stirring the vessel contents to provide the greatest opportunity for all particles to receive exposure to the RF signal. On the other hand, since each particle will need to be read individually, a mechanism for separating the particles may be used in both write and
- 15 read operations. Also, in instances in which each particle will have a different molecule attached, each particle memory must be addressed separately.

- An apparatus for separating the particles to allow individual exposure to the RF signal is illustrated in Figure 7. Here, the particles are
- 20 placed in a vessel 140 which has a funnel 142, or other constricted section, which permits only one particle 150 to pass at a time. It is noted that the particles, as illustrated, are, for purposes of exemplification, depicted as spherical. The particles, however, can be of any shape, including asymmetric shapes. Where the particles are
- 25 asymmetric or of other shapes, the size of the funnel exit and tube should be selected to fit the largest diameter of the particles closely. If a particular orientation of the particle is desired or required for effective transmission, the tube and funnel exit should be designed and oriented to permit only particles in the proper alignment with the tube to exit.

-76-

The RF transmitter 80 is positioned adjacent a tube 144 which receives input from funnel 142. When a particle passes through tube 144 the RF transmitter provides a signal to write to or read from the particle's memory. Means for initiating the RF transmission may include  
5 connection to a mechanical gate or shutter 145 in the funnel 142 which controls the admission of the particle into the tube. As illustrated in Figure 7, however, optical means for detecting the presence of the matrix particle with memory to initiate RF transmission are provided in the form of a laser 146 directed toward the tube 144, which is transparent to the  
10 wavelength of the light emitted by the laser. When the laser light impinges upon the particle [shown with dashed lines] it is reflected toward an optical detector 148 which provides a signal to the host computer 122 to initiate the RF transmission. Alternatively, magnetic means, or any other means for detecting the presence of the particle in  
15 the tube 144 may be used, with the limitation that any electromagnetic radiation used does not induce any reactions in the substances on the particle's surface. After exposure of the individual particle to the RF signal, the particle may be received in one or more vessels for further processing. As illustrated, tube 144 has an exemplary three-way splitter  
20 and selection means, shown here in dashed lines as mechanical gates, for directing the particles to the desired destination.

It is understood that the above description of operation and use of the data storage devices, may be adapted for use with devices that contain volatile memories, such as EEPROMs, flash memory and DRAMs.

#### 25 Other memory or encoded devices

##### Memory devices

In addition to antifuse memory devices, other types of electrically-programmable read-only memories, preferably non-volatile memories, which are known in the art, may be used [see, e.g., U.S. Patent No.  
30 5,335,219]. Chips, such as those sold by Actel, Mosaic, Lattice

-77-

Semiconductor, AVID, Anicare, Destron, Rayethon, Altera, ICT, Xilinx, Intel and Signetics [see, e.g., U.S. Patent Nos. 4,652,528, 5,044,623, 5,099,226, 5,218,343, 5,323,704, 4,333,072, 4,321,069, 4,318,658, 5,121,748, 5,214,409, 5,235,326, 5,257,011 and 5,266,926] may be  
5 used herein. Preprogrammed remotely addressable identification tags, such as those used for tracking objects or animals [see, e.g., U.S. Patent Nos. 5,257,011, 5,235,326, 5,226,926, 5,214,409, 4,333,072, available from AVID, Norco, CA; see, also U.S. Patent No. 5,218,189, 5,416,486, 4,952,928, 5,359,250] and remotely writable versions  
10 thereof are also contemplated for use herein. Preprogrammed tags may be used in embodiments, such as those in which tracking of linked molecules is desired.

Alternatively, the matrices or strips attached thereto may be encoded with a pre-programmed identifying bar code, such as an optical  
15 bar code that will be encoded on the matrix and read by laser. Such pre-coded devices may be used in embodiments in which parameters, such as location in an automated synthesizer, are monitored. The identity of a product or reactant determined by its location or path, which is monitored by reading the chip in each device and storing such information in a  
20 remote computer. Read/write tags such as the IPTT-100 [BioMedic Data Systems, Inc., Maywood, NJ; see, also U.S. Patent Nos. 5,422,636, 5,420,579, 5,262,772, 5,252,962, 5,250,962, and U.S. application Serial No. 08/322,644] are also contemplated for use herein.

Among the particularly preferred devices are the chips [particularly,  
25 the IPTT-100, Bio Medic Data Systems, Inc., Maywood, NJ; see, also U.S. Patent Nos. 5,422,636, 5,420,579, 5,262,772, 5,252,962 and 5,250,962 and U.S. application Serial No. 08/322,644,] that can be remotely encoded and remotely read. These devices, such as the IPTT-100 transponders that are about 8 mm long, include a recording device,  
30 an EEPROM, a passive transponder for receiving an input signal and

-78-

transmitting an output signal in response. In some embodiments here, the devices are modified for use herein by altering the geometry. They are folded in half and the antenna wrapped around the resulting folded structure. This permits convenient insertion into the microvessels and  
5 formation of other combinations.

These devices include a power antenna means [see, e.g., U.S. Patent No. 5,250,944 and U.S. Patent No. 5,420,579] for receiving the input signal, frequency generator and modulator means for receiving the input signal the receive antenna means and for generating the output  
10 signal. The output signal has a frequency different from the input frequency, outputs the output signal in response the input signal. The input signal having a first frequency, the output signal has a second frequency that is a multiple of the first frequency, and is greater than the first frequency. It also includes a transmitting antenna means for  
15 receiving the output signal from the frequency generator and modulator means and that transmit the output signal. Data are stored within the transponder within a reprogrammable memory circuit that is programmed by the user [see, e.g., U.S. Patent No. 5,422,636 and EP 0 526 173 A3]. A transponder scanner for scanning and programming the  
20 transponder is also available [Bio Medic Data Systems Inc. DAS-5001 CONSOLE™ System, e.g., U.S. Patent No. 5,252,962 and U.S. Patent No. 5,262,772].

Another such device is a 4 mm chip with an onboard antenna and an EEPROM [Dimensional Technology International, Germany]. This  
25 device can also be written to and read from remotely.

Also, ID tags available from IDTAG™ Inc, particularly the IDT150 read/write transponder [ITDAG™ Ltd. Bracknell, Berks RG12 3XQ, UK], discussed above, are also preferred herein.



-79-

### Encoded devices

It is also contemplated herein, that the memory is not proximate to the matrix, but is separate, such as a remote computer or other recording device. In these embodiments, the matrices are marked  
5 with a unique code or mark of any sort. The identity of each mark is saved in the remote memory, and then, each time something is done to a molecule or biological particle linked to each matrix, the information regarding such event is recorded and associated with the coded identity. After completion of, for example, a synthetic protocol, each matrix is  
10 examined or read to identify the code. Retrieving information that from the remote memory that is stored with the identifying code will permit identification or retrieval of any other saved information regarding the matrix.

For example, simple codes, including bar codes, alphanumeric  
15 characters or other visually or identifiable codes or marks on matrices are also contemplated for use herein. When bar codes or other precoded devices are used, the information can be written to an associated but remote memory, such as a computer or even a piece of paper. The computer stores the bar code that identifies a matrix particle or other  
20 code and information relating to the molecule or biological particle linked to the matrix or other relevant information regarding the linked materials or synthesis or assay. Instead of writing to an on-board memory, information is encoded in a remote memory that stores information regarding the precoded identity of each matrix with bar code and linked  
25 molecules or biological particles. Thus, the precoded information is associated with, for example, the identity of the linked molecule or a component thereof, or a position (such as X-Y coordinates in a grid). This information is transmitted to a memory for later retrieval. Each treatment or synthetic step that is performed on the linked molecule or

-80-

biological particle is transmitted to the remote memory and associated with the precoded ID.

For example, an amino acid is linked to a matrix particle that is encoded with or marked with a bar code or even a letter such as "A" or other coded mark. The identity the amino acid linked to the matrix particle "A" is recorded into a memory. This particle is mixed with other particles, each with a unique identifier or mark, and this mixture is then treated to a synthetic step. Each particle is individually scanned or viewed to see what mark is on each particle and the remote memory is written to describe the synthetic step, which is then associated with each unique identifier in the memory, such as the computer or piece of paper. Thus, in the remote memory the original amino acid linked to particle A is stored. After the synthetic step, the identify of the next amino acid is stored in the memory associated with "A" as is the identity of the next amino acid added. At the end of the synthesis, the history of each particle can be read by scanning the particle or visually looking at the particle and noting its bar code or mark, such as A. The remote memory is then queried to determine what amino acids are linked to the particle identified as "A" [see, e.g., Fig 20].

For example, many combinatorial libraries contain a relatively small number of discrete compounds [ $10^2$ - $10^4$ ] in a conveniently manipulable quantity, rather than millions of members in minute quantities. These small libraries are ideal for use with the methods and matrices with memories herein. They may also be used in methods in which the memory is not in proximity to the matrix, but is a remote memory, such as a computer or a table of information stored even on paper. The system depicted in FIGURE 20 is ideal for use in these methods.

Polypropylene or other inert polymer, including fluoropolymers or scintillating polymers are molded into a convenient geometry and size, such an approximately 5 mm x 5 mm x 5 mm cube [or smaller or larger]

-81-

with a unique identifying code imprinted, preferably permanently, on one side of each cube. If, for example, a three element code is used, based on all digits (0 to 9) and all letters of the alphabet, a collection of 46,666 unique three element codes are available for imprinting on the cubes.

- 5** The cubes are surface grafted with a selected monomer [or mixture of monomer], such as styrene. Functionalization of the resulting polymer provides a relatively large surface area for chemical syntheses and subsequent assaying [on a single platform]. For example, a 5 x 5 x 5 mm<sup>3</sup> cube has a surface area of 150 mm<sup>2</sup>, which is equivalent to about
- 10** 2-5  $\mu$ mol achievable loading, which is about 1-2.5 mg of compounds with a molecular weight of about 500. A simple computer program or protocol can direct split and pool during synthesis and the information regarding each building block of the linked molecules on each cube conveniently recorded in the memory [i.e., computer] at each step in the synthesis.
- 15** Since the cubes [herein called MACROCUBES<sup>™</sup> or MACROBEADS<sup>™</sup>] are relatively large, they can be read by the eye or any suitable device during synthesis and the associated data can be manually entered into a computer or even written down. The cubes can include scintillant or fluorophore or label and used in any of the assay formats described herein
- 20** or otherwise known to those of skill in the art.

- For example, with reference to FIGURE 20, polypropylene, polyethylene or fluorophore raw material [any such material described herein, particularly the Moplen resin e.g., V29G PP resin from Montell, Newark DE, a distributor for Himont, Italy] 1 is molded, preferably into a
- 25** cube, preferably about 5 x 5 x 5 mm<sup>3</sup> and engraved, using any suitable imprinting method, with a code, preferably a three element alphanumeric code, on one side. The cube can be weighted or molded so that all cubes will orient in the same direction. The engraved cubes 2 are then surface-grafted 3 and functionalized using methods described herein or

-82-

known to those of skill in this art, to produce cubes [MACROBEADS™ or MACROCUBES™] or devices any selected geometry 4.

#### Optically or magnetically programmed devices

In addition to electrically-programmable means for storing  
5 information on the matrix particles, optical or magnetic means may be used. One example of an optical storage means is provided in U.S. Patent No. 5,136,572, issued August 4, 1992, of Bradley, which is incorporated herein by reference. Here, an array of stabilized diode lasers emits fixed wavelengths, each laser emitting light at a different  
10 wavelength. Alternatively, a tunable diode laser or a tunable dye laser, each of which is capable of emitting light across a relatively wide band of wavelengths, may be used. The recording medium is photochemically active so that exposure to laser light of the appropriate wavelength will form spectral holes.

15 As illustrated in Figure 8, an optical write/read system is configured similar to that of the embodiment of Figure 7, with a vessel 212 containing a number of the particles which are separated and oriented by passing through a constricted outlet into a write/read path 206 that has an optically-transparent tube [i.e., optically transparent to  
20 the required wavelength(s)] with a cross-section which orients the particles as required to expose the memory surface to the laser 200 which is capable of emitting a plurality of discrete, stable wavelengths. Gating and detection similar to that described for the previous embodiment may be used and are not shown. Computer 202 controls  
25 the tuning of laser 200 so that it emits light at a unique wavelength to record a data point. Memory within computer 202 stores a record indicating which process step corresponds to which wavelength. For example, for process A, wavelength  $\lambda_1$ , e.g., 630 nm [red], for process C,  $\lambda_2$ , e.g., 550 nm [yellow], and for process E,  $\lambda_3$ , e.g., 480 nm [blue], etc.  
30 The recording medium 204 is configured to permit orientation to

-83-

repeatably expose the recording side of the medium to the laser beam each time it passes through tube 206. One possible configuration, as illustrated here, is a disc.

To write onto the recording medium 204, the laser 200 emits light  
5 of the selected wavelength to form a spectral hole in the medium. The light is focussed by lens 208 to illuminate a spot on recording medium 204. The laser power must be sufficient to form the spectral hole. For reading, the same wavelength is selected at a lower power. Only this wavelength will pass through the spectral hole, where it is detected by  
10 detector 210, which provides a signal to computer 202 indicative of the recorded wavelength. Because different wavelengths are used, multiple spectral holes can be superimposed so that the recording medium can be very small for purposes of tagging. To provide an analogy to the electrical memory embodiments, each different wavelength of light  
15 corresponds to an address, so that each laser writes one bit of data. If a large number of different steps are to be performed for which each requires a unique data point, the recording media will need to be sufficiently sensitive, and the lasers well-stabilized, to vary only within a narrow band to assure that each bit recorded in the media is distinguishable. Since  
20 only a single bit of information is required to tag the particle at any given step, the creation of a single spectral hole at a specific wavelength is capable of providing all of the information needed. The host computer then makes a record associating the process performed with a particular laser wavelength.

25 For reading, the same wavelength laser that was used to create the spectral hole will be the only light transmitted through the hole. Since the spectral holes cannot be altered except by a laser having sufficient power to create additional holes, this type of memory is effectively non-volatile. Further, the recording medium itself does not have any  
30 operations occurring within its structure, as is the case in electrical

-84-

memories, so its structure is quite simple. Since the recording medium is photochemically active, it must be well encased within an optically transmissive [to the active optical wavelength(s)], inert material to prevent reaction with the various processing substances while still

5 permitting the laser light to impinge upon the medium. In many cases, the photochemical recording media may be erased by exposure to broad spectrum light, allowing the memory to be reused.

Writing techniques can also include the formation of pits in the medium. To read these pits, the detector 210 will be positioned on the

10 same side of the write/read tube 206 as the laser 200 to detect light reflected back from the medium. Other types of optical data storage and recording media may be used as are known in the art. For example, optical discs, which are typically plastic-encapsulated metals, such as aluminum, may be miniaturized, and written to and read from using

15 conventional optical disc technology. In such a system, the miniature discs must be aligned in a planar fashion to permit writing and reading. A modification of the funnel system, described above, will include a flattened tube to insure the proper orientation. Alternatively, the discs can be magnetically oriented. Other optical recording media that may be

20 appropriate for use in the recording devices and combinations herein include, but are not limited to, magneto-optical materials, which provide the advantage of erasability, photochromic materials, photoferroelectric materials, photoconductive electro-optic materials, all of which utilize polarized light for writing and/or reading, as is known in the art. When

25 using any form of optical recording, however, considerations must be made to insure that the selected wavelength of light will not affect or interfere with reactions of the molecules or biological particles linked to or in proximity to matrix particles.

### Three dimensional optical memories

Another device that is suitable for use in the matrix with memory combinations are optical memories that employ rhodopsins, particularly bacteriorhodopsin [BR], or other photochromic substances that change  
5 between two light absorbing states in response to light of each of two wavelengths [see, e.g., U.S. Patent No. 5,346,789, 5,253,198 and 5,228,001; see, also Birge (1990) Ann. Rev. Phys. Chem 41:683-733]. These substances, particularly BR, exhibit useful photochromic and optoelectrical properties. BR, for example, has extremely large optical  
10 nonlinearities, and is capable of producing photoinduced electrical signals whose polarity depends on the prior exposure of the material to light of various wavelengths as well as on the wavelength of the light used to induce the signal. These properties are useful for information storage and computation. Numerous applications of this material have been designed,  
15 including its use as an ultrafast photosignal detector, its use for dynamic holographic recording, and its use for data storage, which is of interest herein.

The rhodopsins include the visual rhodopsins, which are responsible for the conversion of light into nerve impulses in the image  
20 resolving eyes of mollusks, anthropods, and vertebrates, and also bacteriorhodopsin [BR]. These proteins also include a class of proteins that serve photosynthetic and phototactic functions. The best known BR is the only protein found in nature in a crystalline membrane, called the "purple membrane" of Halobacterium Halobium. This membrane converts  
25 light into energy via photon-activated transmembrane proton pumping. Upon the absorption of light, the BR molecule undergoes several structural transformations in a well-defined photocycle in which energy is stored in a proton gradient formed upon absorption of light energy. This proton gradient is subsequently utilized to synthesize energy-rich ATP.

-86-

The structural changes that occur in the process of light-induced proton pumping of BR are reflected in alterations of the absorption spectra of the molecule. These changes are cyclic, and under usual physiological conditions bring the molecule back to its initial BR state

5 after the absorption of light in about 10 milliseconds. In less than a picosecond after BR absorbs a photon, the BR produces an intermediate, known as the "J" state, which has a red-shifted absorption maximum. This is the only light-driven event in the photocycle; the rest of the steps are thermally driven processes that occur naturally. The first form, or

10 state, following the photon-induced step is called "K", which represents the first form of light-activated BR that can be stabilized by reducing the temperature to 90 ° K. This form occurs about 3 picoseconds after the J intermediate at room temperature. Two microseconds later there occurs an "L" intermediate state which is, in turn, followed in 50 microseconds

15 by an "M" intermediate state.

There are two important properties associated with all of the intermediate states of this material. The first is their ability to be photochemically converted back to the basic BR state. Under conditions where a particular intermediate is made stable, illumination with light at a

20 wavelength corresponding to the absorption of the intermediate state in question results in regeneration of the BR state. In addition, the BR state and intermediates exhibit large two-photon absorption processes which can be used to induce interconversions among different states.

The second important property is light-induced vectorial charge

25 transport within the molecule. In an oriented BR film, such a charge transport can be detected as an electric signal. The electrical polarity of the signal depends on the physical orientation of molecules within the material as well as on the photochemical reaction induced. The latter effect is due to the dependence of charge transport direction on which

30 intermediates [including the BR state] are involved in the photochemical



-87-

reaction of interest. For example, the polarity of an electrical signal associated with one BR photochemical reaction is opposite to that associated with a second BR photochemical reaction. The latter reaction can be induced by light with a wavelength around 412 nm and is  
5 completed in 200 ns.

In addition to the large quantum yields and distinct absorptions of BR and M, the BR molecule [and purple membrane] has several intrinsic properties of importance in optics. First, this molecule exhibits a large two-photon absorption cross section. Second, the crystalline nature and  
10 adaptation to high salt environments makes the purple membrane very resistant to degeneration by environmental perturbations and thus, unlike other biological materials, it does not require special storage. Dry films of purple membrane have been stored for several years without degradation. Furthermore, the molecule is very resistant to photochemical degradation.

15 Thus, numerous optical devices, including recording devices have been designed that use BR or other rhodopsin as the recording medium [see, e.g., U.S. Patent No. 5,346,789, 5,253,198 and 5,228,001; see, also Birge (1990) Ann. Rev. Phys. Chem 41:683-733]. Such recording devices may be employed in the methods and combinations provided  
20 herein.

#### Event-detecting embodiment

Another embodiment of the combinations herein utilizes a recording device that can detect the occurrence of a reaction or event or the status of any external parameter, such as pH or temperature, and record a such  
25 occurrence or parameter in the memory. Any of the above devices may be modified to permit such detection. For example, the chip with the antifuse memory array with decoder, rectifier components and RF antenna, can be modified by addition of a photodetector and accompanying amplifier components as shown in Figure 9. The  
30 photodetector will be selected so that it is sensitive to the frequencies of

-88-

expected photoemissions from reactions of interest. To maintain the chip's passive operation, the photodetector circuitry may use voltage supplied by the same RF signal that is used to write other data to memory, so that no detection of photoemission will occur unless RF or  
5 other power is applied to provide bias and drain voltage. If an active device is used, the power supplied by the battery can provide operational voltage to the photodetector circuitry, independent of any transmitted signal. The voltage supplied by the photodetector can be used in a number of different ways. For example:

10 1) The threshold voltage for writing to memory will exceed the voltage supplied by the RF signal, which will still contain the address information. In order to write, additional voltage must be provided by the photodetector so that the sum of the voltages exceeds the threshold. ( $V_{RF} < V_T < V_{RF} + V_{PD}$ ). This permits the RF supplied voltage to go to the  
15 correct address, however, no writing will occur unless a photoemission has been detected by the detector. Therefore, there will be no record of exposure to a particular process step unless a sufficient reaction has occurred to generate the required photoemission. Since the address signal can still get to the memory array without the extra voltage, reading  
20 of recorded data can be achieved without any special circuitry. If the memory device is an active device, a similar mechanism can be used in which only the sum of the voltages is sufficient to record an occurrence.

2) The threshold voltage for writing to memory will be provided by the RF signal alone, and the RF signal will include address information.  
25 ( $V_T < V_{RF}$ ). However, unless voltage from the photodetector is supplied to a "gating" transistor, access to the memory array is prevented so that no writing occurs unless a photoemission is detected. (This embodiment is illustrated.) This will require a special provision for opening the gate during read operations to permit access to the memory array. Since the

-89-

gating transistor will conduct a signal only in the event of photoemission, this embodiment will work equally well with passive and active memory devices.

3) The RF signal provides sufficient voltage to exceed the  
5 threshold voltage. ( $V_T < V_{RF}$ ). Voltage from the photodetector is used to create a write potential difference at an additional address location which is carried in the RF signal. For example, if the RF signal is addressing column 3, row 3, column 32 could be connected only to the  
10 photodetector circuit's output so that, when a photoemission occurs, the write signal will create antifuses [or in the case of EEPROM, standard fuses] at addresses 3,3 and 32,3. If no photoemission occurs, only address 3,3 will have an antifuse formed, providing a record of exposure of the matrix to a particular process step even without the occurrence of a detectable reaction. Special provisions, such as software within the  
15 host computer in combination with mask-programmed interconnections within the decode circuitry of the memory device, must be made to assure that more than one column in a single row of the array is polled during read operations so that both memory locations are read.

In addition to the above-described methods for recording the  
20 occurrence of photo-emitting reactions, the photodetector, while still integrated on the same substrate with the basic memory matrix for recording transmitted signals, can be connected to its own independent memory matrix. In this embodiment, the photodetector's memory matrix can be connected to separate transceiver circuitry with an antenna tuned  
25 to a different frequency from that of the basic memory. During the read operation, the memory device will be exposed to two different radio frequency signals, one for the basic memory, the other for the photodetection circuit memory. If only the photoemission information is required, only the corresponding frequency signal need be provided during  
30 the read operation.

-90-

Depending on the type of energy release that occurs during a reaction, other types of sensors may be used in addition to photodetectors or in place thereof. In addition changes in ion concentration may also be detected. Many such sensors will be capable of generating an electrical signal that can be used as described above for the photodetectors. These sensing devices may also be incorporated onto the substrate and electrically connected to the memory device, providing data points within the device's memory under the appropriate write conditions. For example, temperature sensing elements can be made from semiconductor liquid crystal and fluorescent crystals, and addition to conventional thermocouples created by placing two different metals in contact at the detection point. It is also possible to include radiation, pH and pCO<sub>2</sub> sensors in a similar manner, using materials that respond to the detected variables by generating a voltage potential that can be conducted to the memory device and recorded.

The reaction-detecting embodiment may be advantageously used in assays, such as the SPA, HTRF, FET, FRET and FP assays described below. In these assays, reaction, such as receptor binding, produces a detectable signal, such as light, in the matrix. If a matrix with memory with a photodetection circuit is used, occurrence of the binding reaction will be recorded in memory.

### **C. The combinations and preparation thereof**

Combinations of a miniature recording device that contains or is a data storage unit linked to or in proximity with matrices or supports used in chemical and biotechnical applications, such as combinatorial chemistry, peptide synthesis, nucleic acid synthesis, nucleic acid amplification methods, organic template chemistry, nucleic acid sequencing, screening for drugs, particularly high throughput screening, phage display screening, cell sorting, drug delivery, tracking of biological particles and other such methods, are provided. These combinations of matrix material

-91-

with data storage unit [or recording device including the unit] are herein referred to as matrices with memories. These combinations have a multiplicity of applications, including combinatorial chemistry, isolation and purification of target macromolecules, capture and detection of

**5** macromolecules for analytical purposes, high throughput screening protocols, selective removal of contaminants, enzymatic catalysis, drug delivery, chemical modification, scintillation proximity assays, FET, FRET and HTRF assays, immunoassays, receptor binding assays, drug screening assays, information collection and management and other

**10** uses. These combinations are particularly advantageous for use in multianalyte analyses. These combinations may also be advantageously used in assays in which a electromagnetic signal is generated by the reactants or products in the assay. These combinations may be used in conjunction with or may include a sensor element, such as an element

**15** that measures a solution parameter, such as pH. Change in such parameter, which is recorded in the memory will indicate a reaction event of interest, such as induction of activity of a receptor or ion channel, has occurred. The combination of matrix with memory is also advantageously used in multiplex protocols, such as those in which a

**20** molecule is synthesized on the matrix, its identity recorded in the matrix, the resulting combination is used in an assay or in a hybridization reaction. Occurrence of the reaction can be detected externally, such as in a scintillation counter, or can be detected by a sensor that writes to the memory in the matrix. Thus, combinations of matrix materials,

**25** memories, and linked or proximate molecules and biological materials and assays using such combinations are provided.

The combinations contain (i) a miniature recording device that contains one or more programmable data storage devices [memories] that can be remotely read and in preferred embodiments also remotely

**30** programmed; and (ii) a matrix as described above, such as a particulate

-92-

support used in chemical syntheses. The remote programming and reading is preferably effected using electromagnetic radiation, particularly radio frequency or radar. Depending upon the application the combinations will include additional elements, such as scintillants, photodetectors, pH sensors and/or other sensors, and other such elements.

#### 1. Preparation of matrix-memory combinations

In preferred embodiments, the recording device is cast in a selected matrix material during manufacture. Alternatively, the devices can be physically inserted into the matrix material, the deformable gel-like materials, or can be placed on the matrix material and attached by a connector, such as a plastic or wax or other such material. Alternatively, the device or device(s) may be included in an inert container in proximity to or in contact with matrix material.

#### 2. Non-linked matrix-memory combinations

The recording device with memory can be placed onto the inner surface of a vessel, such as a microtiter plate or vial or tube in which the reaction steps are conducted. Alternatively, the device can be incorporated into the vessel material, such into the a wall of each microtiter well or vial or tube in which the reaction is conducted. As long as the molecules or biological particles remain associated with the well, tube or vial, their identity can be tracked. Also of interest herein are the multiwell "chips" [such as those available from Orchid Biocomputer, Inc. Princeton, NJ, see, e.g., U.S. Patent Nos. 5,047,371, 4,952,531, 5,043,222, 5,277,724, 5,256,469 and Prabhu et al. (1992) Proc. SPIE-Int. Soc. Opt. Eng. 1847 NUMBER: Proceedings of the 1992 International Symposium on Microelectronics, pp.601-6], that are silicone based chips that contain 10,000 microscopic wells connected by hair-thin glass tubes to tiny reservoirs containing reagents for synthesis of compounds in each well. Each well can be marked with a code and the

-93-

code associated with the identity of the synthesized compound in each well. Ultimately, a readable or read/write memory may be incorporated into each well, thus permitting rapid and ready identification of the contents of each well.

- 5           In a particularly preferred embodiment, one or more recording devices with memory and matrix particles are sealed in a porous non-reactive material, such as polypropylene or teflon net, with a pore size smaller than the particle size of the matrix and the device. Typically one device per about 1 to 50 mg, preferably 5 to 30, more preferably 5 to
- 10 20 mg of matrix material, or in some embodiments up to gram, generally 50 to 250 mg, preferably 150 mg to about 200 mg, and one device is sealed in a porous vessel a microvessel [MICROKAN™]. The amount of matrix material is a function of the size of the device and the application in which the resulting matrix with memory is used, and, if necessary can
- 15 be empirically determined. Generally, smaller sizes are desired, and the amount of material will depend upon the size of the selected recording device.

- The resulting microvessels are then encoded, reactions, such as synthetic reactions, performed, and read, and if desired used in desired
- 20 assays or other methods.

### 3. Preparation of matrix-memory-molecule or biological particle combinations

- In certain embodiments, combinations of matrices with memories and biological particle combinations are prepared. For example, libraries
- 25 [e.g., bacteria or bacteriophage, or other virus particles or other particles that contain genetic coding information or other information] can be prepared on the matrices with memories, and stored as such for future use or antibodies can be linked to the matrices with memories and stored for future use.

#### 4. Combinations for use in proximity assays

In other embodiments the memory or recording device is coated or encapsulated in a medium, such as a gel, that contains one or more fluophors or one or more scintillants, such as 2,5-diphenyloxazole [PPO] and/or 1,4-bis-[5-phenyl-(oxazolyl)]benzene [POPOP] or FlexiScint [a gel with scintillant available from Packard, Meriden, CT] or yttrium silicates. Any fluophore or scintillant or scintillation cocktail known to those of skill in the art may be used. The gel coated or encased device is then coated with a matrix suitable, such as glass or polystyrene, for the intended application or application(s). The resulting device is particularly suitable for use as a matrix for synthesis of libraries and subsequent use thereof in scintillation proximity assays.

Similar combinations in non-radioactive energy transfer proximity assays, such as HTRF, FP, FET and FRET assays, which are described below. These luminescence assays are based on energy transfer between a donor luminescent label, such as a rare earth metal cryptate [e.g., Eu trisbipyridine diamine (EuTBP) or Tb tribipyridine diamine (TbTBP)] and an acceptor luminescent label, such as, when the donor is EuTBP, allophycocyanin (APC), allophycocyanin B, phycocyanin C or phycocyanin R, and when the donor is TbTBP, a rhodamine, thiomine, phycocyanin R, phycoerythrocyanin, phycoerythrin C, phycoerythrin B or phycoerythrin R. Instead of including a scintillant in the combination, a suitable fluorescent material, such as allophycocyanin (APC), allophycocyanin B, phycocyanin C, phycocyanin R; rhodamine, thiomine, phycocyanin R, phycoerythrocyanin, phycoerythrin C, phycoerythrin B or phycoerythrin R is included. Alternatively, a fluorescent material, such a europium cryptate is incorporated in the combination.



-95-

### 5. Other variations and embodiments

The combination of memory with matrix particle may be further linked, such as by welding using a laser or heat, to an inert carrier or other support, such as a teflon strip. This strip, which can be of any convenient size, such as 1 to 10 mm by about 10 to 100  $\mu$ M will render the combination easy to use and manipulate. For example, these memories with strips can be introduced into 10 cm culture dishes and used in assays, such as immunoassays, or they can be used to introduce bacteria or phage into cultures and used in selection assays. The strip may be encoded or impregnated with a bar code to further provide identifying information.

Microplates containing a recording device in one or a plurality of wells are provided. The plates may further contain embedded scintillant or a coating of scintillant [such as FlashPlate™, available from DuPont NEN®, and plates available from Packard, Meriden, CT] FLASHPLATE™ is a 96 well microplate that is precoated with plastic scintillant for detection of  $\beta$ -emitting isotopes, such as  $^{125}\text{I}$ ,  $^3\text{H}$ ,  $^{35}\text{S}$ ,  $^{14}\text{C}$  and  $^{33}\text{P}$ . A molecule is immobilized or synthesized in each well of the plate, each memory is programmed with the identify of each molecule in each well. The immobilized molecule on the surface of the well captures a radiolabeled ligand in solution results in detection of the bound radioactivity. These plates can be used for a variety of radioimmunoassays [RIAs], radioreceptor assays [RRAs], nucleic acid/protein binding assays, enzymatic assays and cell-based assays, in which cells are grown on the plates.

Another embodiment is depicted in FIGURE 19. The reactive sites, such as amines, on a support matrix [1 in the FIGURE] in combination with a memory [a MICROKAN™, a MICROTUBE™, a MACROBEAD™, a MICROCUBE™ or other matrix with memory combination] are differentiated by reacting them with a selected reaction of Fmoc-glycine

-96-

and Boc-glycine, thereby producing a differentiated support [2]. The Boc groups groups on 2 are then deprotected with a suitable agent such as TFA, to produce 3. The resulting free amine groups are coupled with a fluophore [or mixture A and B, to produce a fluorescent support 4, which  
5 can be used in subsequent syntheses or for linkage of desired molecules or biological particles, and then used in fluorescence assays and SPAs.

#### D. The recording and reading and systems

Systems for recording and reading information are provided. The systems include a host computer or decoder/encoder instrument, a trans-  
10 mitter, a receiver and the data storage device. The systems also can include a funnel-like device or the like for use in separating and/or tagging single memory devices. In practice, an EM signal, preferably a radio frequency signal is transmitted to the data storage device. The antenna or other receiver means in the device detects the signal and transmits it  
15 to the memory, whereby the data are written to the memory and stored in a memory location.

Mixtures of the matrix with memory-linked molecules or biological particles may be exposed to the EM signal, or each matrix with memory [either before, after or during linkage of the biological particles or  
20 molecules] may be individually exposed, using a device, such as that depicted herein, to the EM signal. Each matrix with memory, as discussed below, will be linked to a plurality of molecules or biological particles, which may be identical or substantially identical or a mixture of molecules or biological particles depending, upon the application and  
25 protocol in which the matrix with memory and linked [or proximate] molecules or biological particles is used. The memory can be programmed with data regarding such parameters.

-97-

The location of the data, which when read and transmitted to the host computer or decoder/encoder instrument, corresponds to identifying information about linked or proximate molecules or biological particles. The host computer or decoder/encoder instrument can either identify the  
5 location of the data for interpretation by a human or another computer or the host computer or the decoder/encoder can be programmed with a key to interpret or decode the data and thereby identify the linked molecule or biological particle.

As discussed above, the presently preferred system for use is the  
10 IPTT-100 transponder and DAS-5001 CONSOLE™ [Bio Medic Data Systems, Inc., Maywood, NJ; see, e.g., U.S. Patent Nos. 5,422,636, 5,420,579, 5,262,772, 5,252,962 and 5,250,962, 5,252,962 and 5,262,772].

These systems may be automated or may be manual.

#### 15                   **Manual sytem**

The presently preferred manual system includes a transponder, particularly the BMDS transponder described below or an IDTAG™ transponder, described above, and uses the corresponding reading and writing device, which has been reconfigured and repackaged, such as in  
20 FIGURE 17, described in the EXAMPLES. An example of the operation of the system of FIGURE 17 is illustrated in FIGURE 18 and described in EXAMPLE 4. Briefly, the user manually places a microvessel 180 within the recessed area 176 so that the interrogation signal 185 provides a response to the controllers indicating the presence on the microvessel,  
25 and information is read from or written to the transponder..

This will include microvessels, such as MICROKANS™ or MICROTUBES™, read/writer hardware [such as that available from BMDS or IDTAG™] connected to a PC and software running on the PC that performs a user interface and system control function. The software is

-98-

designed to facilitate the a number of aspects of synthetic combinatorial chemistry libraries, including: organization, planning and design, synthesis compound formula determination, molecular weight computation, reporting of plans, status and results.

- 5 In particular, for each chemical library, the software creates a data base file. This file contains all of the information pertinent to the library, including chemical building blocks to be used, the design of the library in terms of steps and splits, and what synthesis has been performed. This file oriented approach allows many different chemical library projects to
- 10 be conducted simultaneously. The software allows the user to specify what chemical building blocks are to be used and their molecular weights. The user specifies the number of steps, the number of "splits" at each step, and what chemical building blocks are to be used at each split. The user may also enter the name of the pharmacophore and its molecular
- 15 weight. Additionally, the user may specify graphical chemical diagrams for the building blocks and the pharmacophore. This information is useful in displaying resulting compounds. The software records all of the above "design" information. It computes and displays the size of the library. It may also predict the range of molecular weights of the resulting
- 20 compounds.

- For example, the user specifies that there will be eight chemical building blocks. Their names are entered, and the user enters a unique letter codes for each: A, B, C, D, E, F, G and H. The user specifies that there will be three steps. Step one will have four splits, appending the A,
- 25 B, C and D building blocks. Step two will also have four splits, adding the B, D, E and H building blocks. Step three will have six splits, adding the B, C, D, E, F and G building blocks. The software computes that the library will contain 96 ( $4 \times 6 \times 5 = 96$ ) unique compounds. With the planning and design completed, the software helps the user perform the
- 30 synthesis steps. This is done in concert with the reader/writer hardware

-99-

[transceiver or a scanner, such as the BMDS - DAS 5003] or a similar device available from IDTAG Ltd [Bracknell, Berks RG12 3XQ, UK] and devices, such as the MICROKAN™ or MICROTUBE™ microvessel with memory devices. Before the synthesis begins, the microvessels are filled

5 with polymer resin. The microvessel devices are, one at a time placed upon the scanner. The device and software reads the contents of the data encoded in the recording device, transponder, such as the BMDS tag or the IDTAG™ tag, contained in each microvessel. The software, chooses which building block shall be added to the compound contained in each

10 microvessel. It directs the transceiver to write encoded data to the transponder, indicating which building block this is. The software displays a message which directs the user to place the microvessel in the appropriate reaction vessel so that the chosen building block will be added. This process is repeated a plurality of times with each

15 microvessel and for each synthetic step the planned steps of the library.

The software then uses the scanner to read a tag and receive its encoded information. Using the user-entered compound names stored in the library's data base, the software translates the encoded information into the names of the chemical building blocks. The software can also

20 display compounds graphically, using the graphical information specified by the user. The software calculates the molecular weight of compounds from the data provided for the pharmacophore and building blocks. The software facilitates the recording of progress through the above process. The software generates displays and reports which illustrate

25 this and all of the above planning, design, compound data, and graphical representations of compounds.

-100-

## E. Tools and applications using matrices with memories

### 1. Tools

The matrix with memory and associated system as described herein is the basic tool that can be used in a multitude of applications, including any reaction that incorporates a functionally specific (i.e. in the reaction) interaction, such as receptor binding. This tool is then combined with existing technologies or can be modified to produce additional tools.

For example, the matrix with memory combination, can be designed as a single analyte test or as a multianalyte test and also as a multiplexed assay that is readily automated. The ability to add one or a mixture of matrices with memories, each with linked or proximate molecule or biological particle to a sample, provides that ability to simultaneously determine multiple analytes and to also avoid multiple pipetting steps. The ability to add a matrix with memory and linked molecules or particles with additional reagents, such as scintillants, provides the ability to multiplex assays.

As discussed herein, in one preferred embodiment the matrices are particulate and include adsorbed, absorbed, or otherwise linked or proximate, molecules, such as peptides or oligonucleotides, or biological particles, such as cells. Assays using such particulate memories with matrices may be conducted "on bead" or "off bead". On bead assays are suitable for multianalyte assays in which mixtures of matrices with linked molecules are used and screened against a labeled known. Off bead assays may also be performed; in these instances the identity of the linked molecule or biological particle must be known prior to cleavage or the molecule or biological particle must be in some manner associated with the memory.

In other embodiments the matrices with memories use matrices that are continuous, such as microplates, and include a plurality of

-101-

memories, preferably one memory/well. Of particular interest herein are matrices, such as Flash Plates™ [NEN, Dupont], that are coated or impregnated with scintillant or fluophore or other luminescent moiety or combination thereof, modified by including a memory in each well. The  
5 resulting memory with matrix is herein referred to as a luminescing matrix with memory. Other formats of interest that can be modified by including a memory in a matrix include the Multiscreen Assay System [Millipore] and gel permeation technology.

10                   **2. Scintillation proximity assays (SPAs) and scintillant-containing matrices with memories**

Scintillation proximity assays are well known in the art [see, e.g., U.S. Patent No. 4,271,139; U.S. Patent No. 4,382,074; U.S. Patent No. 4,687,636; U.S. Patent No. 4,568,649; U.S. Patent No. 4,388,296; U.S. Patent No. 5,246,869; International PCT Application No.  
15 WO 94/26413; International PCT Application No. WO 90/03844; European Patent Application No. 0 556 005 A1; European Patent Application No. 0 301 769 A1; Hart *et al.* (1979) Molec. Immunol. 16:265-267; Udenfriend *et al.* (1985) Proc. Natl. Acad. Sci. U.S.A. 82:8672-8676; Nelson *et al.* (1987) Analyt. Biochem 165:287-293;  
20 Heath, *et al.* (1991) Methodol. Surv. Biochem. Anal. 21:193-194; Mattingly *et al.* (1995) J. Memb. Sci. 98:275-280; Pernelle (1993) Biochemistry 32:11682-116878; Bosworth *et al.* (1989) Nature 341:167-168; and Hart *et al.* (1989) Nature 341:265]. Beads [particles] and other formats, such as plates and membranes have been developed.

25                   SPA assays refer to homogeneous assays in which quantifiable light energy produced and is related to the amount of radioactively labelled products in the medium. The light is produced by a scintillant that is incorporated or impregnated or otherwise a part of a support matrix. The support matrix is coated with a receptor, ligand or other

-102-

capture molecule that can specifically bind to a radiolabeled analyte, such as a ligand.

**a. Matrices**

Typically, SPA uses fluomicrospheres, such as diphenyloxazole-  
5 latex, polyacrylamide-containing a fluophore, and polyvinyltoluene [PVT]  
plastic scintillator beads, and they are prepared for use by adsorbing  
compounds into the matrix. Also fluomicrospheres based on organic  
phosphors have been developed. Microplates made from scintillation  
10 plastic, such as PVT, have also been used [see, e.g., International PCT  
Application No. WO 90/03844]. Numerous other formats are presently  
available, and any format may be modified for use herein by including one  
or more recording devices.

Typically the fluomicrospheres or plates are coated with acceptor  
molecules, such as receptors or antibodies to which ligand binds  
15 selectively and reversibly. Initially these assays were performed using  
glass beads containing fluors and functionalized with recognition groups  
for binding specific ligands [or receptors], such as organic molecules,  
proteins, antibodies, and other such molecules. Generally the support  
bodies used in these assays are prepared by forming a porous amorphous  
20 microscopic particle, referred to as a bead [see, e.g., European Patent  
Application No. 0 154,734 and International PCT Application No. WO  
91/08489]. The bead is formed from a matrix material such as  
acrylamide, acrylic acid, polymers of styrene, agar, agarose, polystyrene,  
and other such materials, such as those set forth above. Cyanogen  
25 bromide has been incorporated into the bead into to provide moieties for  
linkage of capture molecules or biological particles to the surface.  
Scintillant material is impregnated or incorporated into the bead by  
precipitation or other suitable method. Alternatively, the matrices are  
formed from scintillating material [see, e.g., International PCT Application  
30 No. WO 91/08489, which is based on U.S. application Serial No.



-103-

07/444,297; see, also U.S. Patent No. 5,198,670], such as yttrium silicates and other glasses, which when activated or doped respond as scintillators. Dopants include Mn, Cu, Pb, Sn, Au, Ag, Sm, and Ce. These materials can be formed into particles or into continuous matrices.

- 5 For purposes herein, they are used to coat, encase or otherwise be in contact with one or a plurality of recording devices.

Assays are conducted in normal assay buffers and requires the use of a ligand labelled with an isotope, such as  $^3\text{H}$  and  $^{125}\text{I}$ , that emits low-energy radiation that is readily dissipated easily in an aqueous medium.

- 10 Because  $^3\text{H}$   $\beta$  particles and  $^{125}\text{I}$  Auger electrons have average energies of 6 and 35 keV, respectively, their energies are absorbed by the aqueous solutions within very small distances ( $\sim 4 \mu\text{m}$  for  $^3\text{H}$   $\beta$  particles and  $35 \mu\text{m}$  for  $^{125}\text{I}$  Auger electrons). Thus, in a typical reaction of 0.1 ml to
- 15 fluomicrosphere to activate the fluor. Bound ligands, however, will be in sufficiently close proximity to the fluomicrospheres to allow the emitted energy to activate the fluor and produce light. As a result bound ligands produce light, but free ligands do not. Thus, assay beads emit light when they are exposed to the radioactive energy from the label bound to
- 20 the beads through the antigen-antibody linkage, but the unreacted radioactive species in solution is too far from the bead to elicit light. The light from the beads will be measured in a liquid scintillation counter and will be a measure of the bound label.

- Memories with matrices for use in scintillation proximity assays
- 25 [SPA] are prepared by associating a memory with a matrix that includes a scintillant. In the most simple embodiment, matrix particles with scintillant [fluomicrospheres] are purchased from Amersham, Packard, NE Technologies [(formerly Nuclear Enterprises, Inc.) San Carlos, CA] or other such source and are associated with a memory, such as by
- 30 including one or more of such beads in a MICROKAN<sup>™</sup> microvessel with a

-104-

recording device. Typically, such beads as purchased are derivatized and coated with selected moieties, such as streptavidin, protein A, biotin, wheat germ agglutinin [WGA], and polylysine. Also available are inorganic fluomicrospheres based on cerium-doped yttrium silicate or  
5 polyvinyltoluene (PVT). These contain scintillant and may be coated and derivatized.

Alternatively, small particles of PVT impregnated with scintillant are used to coat recording devices, such as the IPTT-100 devices [Bio  
Medic Data Systems, Inc., Maywood, NJ; see, also U.S. Patent Nos.  
10 5,422,636, 5,420,579, 5,262,772, 5,252,962, 5,250,962, 5,074,318, and RE 34,936] that have been coated with a protective material, such as polystyrene, teflon, a ceramic or anything that does not interfere with the reading and writing EM frequency(ies). Such PVT particles may be manufactured or purchased from commercial sources such as NE  
15 TECHNOLOGY, INC. [e.g., catalog # 191A, 1-10  $\mu$ m particles]. These particles are mixed with agarose or acrylamide, styrene, vinyl or other suitable monomer that will polymerize or gel to form a layer of this material, which is coated on polystyrene or other protective layer on the recording device. The thickness of the layers may be empirically  
20 determined, but they must be sufficiently thin for the scintillant to detect proximate radiolabels. To make the resulting particles resistant to chemical reaction they may be coated with polymers such as polyvinyltoluene or polystyrene, which can then be further derivatized for linkage and/or synthesis of molecules and biological particles. The  
25 resulting beads are herein called luminescening matrices with memories, and when used in SPA formats are herein referred to as scintillating matrices with memories.

The scintillating matrices with memories beads can be formed by manufacturing a bead containing a recording device and including  
30 scintillant, such as 2,5-diphenyloxazole [PPO] and/or 1,4-bis-[5-phenyl-

-105-

(oxazolyl)]benzene [POPOP] as a coating. These particles or beads are then coated with derivatized polyvinyl benzene or other suitable matrix on which organic synthesis, protein synthesis or other synthesis can be performed or to which organic molecules, proteins, nucleic acids,

- 5 biological particles or other such materials can be attached. Attachment may be effected using any of the methods known to those of skill in the art, including methods described herein, and include covalent, non-covalent, direct and indirect linkages.

- Molecules, such as ligands or receptors or biological particles are
- 10 covalently coupled thereto, and their identity is recorded in the memory. Alternatively, molecules, such as small organics, peptides and oligonucleoties, are synthesized on the beads as described herein so that history of synthesis and/or identity of the linked molecule is recorded in the memory. The resulting matrices with memory particles with linked
- 15 molecules or biological particles may be used in any application in which SPA is appropriate. Such applications, include, but are not limited to: radioimmunoassays, receptor binding assays, enzyme assays and cell biochemistry assays.

- For use herein, the beads, plates and membranes are either
- 20 combined with a recording device or a plurality of devices, or the materials used in preparing the beads, plates or membranes is used to coat, encase or contact a recording device. Thus, microvessels [MICROKANS™] containing SPA beads coated with a molecule or biological particle of interest; microplates impregnated with or coated
- 25 with scintillant, and recording devices otherwise coated with, impregnated with or contacted with scintillant are provided.

- To increase photon yield and remove the possibility of loss of fluor, derivatized fluomicrospheres based on yttrium silicate, that is doped selectively with rare earth elements to facilitate production of light with
- 30 optimum emission characteristics for photomultipliers and electronic

-106-

circuitry have been developed [see, e.g., European Patent Application No. 0 378 059 B1; U.S. Patent No. 5,246,869]. In practice, solid scintillant fibers, such as cerium-loaded glass or based on rare earths, such as yttrium silicate, are formed into a matrix. The glasses may also  
5 include activators, such as terbium, europium or lithium. Alternatively, the fiber matrix may be made from a scintillant loaded polymer, such as polyvinyltoluene. Molecules and biological particles can be adsorbed to the resulting matrix.

For use herein, these fibers may be combined in a microvessel with  
10 a recording device [i.e., to form a MICROKAN™]. Alternatively, the fibers are used to coat a recording device or to coat or form a microplate containing recording devices in each well. The resulting combinations are used as supports for synthesis of molecules or for linking biological particles or molecules. The identity and/or location and/or other  
15 information about the particles is encoded in the memory and the resulting combinations are used in scintillation proximity assays.

Scintillation plates [e.g., FlashPlates™, NEN Dupont, and other such plates] and membranes have also been developed [see, Mattingly et al. (1995) J. Memb. Sci. 98:275-280] that may be modified by including a  
20 memory for use as described herein. The membranes, which can contain polysulfone resin M.W. 752 kD, polyvinylpyrrolidone MW 40 kDA, sulfonated polysulfone, fluor, such as *p*-bis-*o*-methylstyrylbenzene, POP and POPOP, may be prepared as described by Mattingly, but used to coat, encase or contact a recording device. Thus, instead of applying the  
25 polymer solution to a glass plate the polymer solution is applied to the recording device, which, if need is pre-coated with a protective coating, such as a glass, teflon or other such coating.

Further, as shown in the Examples, the recording device may be coated with glass, etched and the coated with a layer of scintillant. The  
30 scintillant may be formed from a polymer, such as polyacrylamide,

-107-

gelatin, agarose or other suitable material, containing fluophors, a scintillation cocktail, FlexiScint [Packard Instrument Co., Inc., Downers Grove, IL] NE Technology beads [see, e.g., U.S. Patent No. 4,588,698 for a description of the preparation of such mixtures]. Alternatively, 5 microplates that contain recording devices in one or more wells may be coated with or impregnated with a scintillant or microplates containing scintillant plastic may be manufactured with recording devices in each well. If necessary, the resulting bead, particle or continuous matrix, such as a microplate, may be coated with a thin layer polystyrene, teflon or 10 other suitable material. In all embodiments it is critical that the scintillant be in sufficient proximity to the linked molecule or biological particle to detect proximate radioactivity upon interaction of labeled molecules or labeled particles with the linked molecule or biological particle.

The resulting scintillating matrices may be used in any application 15 for which scintillation proximity assays are used. These include, ligand identification, single assays, multianalyte assays, including multi-ligand and multi-receptor assays, radioimmunoassays [RIAs], enzyme assays, and cell biochemistry assays [see, e.g., International PCT Application No. WO 93/19175, U.S. Patent No. 5,430,150, Whitford et al. (1991) Phyto-chemical Analysis 2:134-136; Fenwick et al. (1994) Anal. Proc. Including 20 Anal. Commun. 31:103-106; Skinner et al. (1994) Anal. Biochem. 223:259-265; Matsumura et al. (1992) Life Sciences 51:1603-1611; Cook et al. (1991) Structure and Function of the Aspartic Proteinases, Dunn, ed., Penum Press, NY, pp. 525-528; Bazendale et al. in (1990) 25 Advances in Prostaglandin, Thromboxane and Leukotriene Research, Vol. 21, Samuelsson et al., eds., Raven Press, NY, pp 302-306].

-108-

**b. Assays****(1) Receptor Binding Assays**

Scintillating matrices with memories beads can be used, for example, in assays screening test compounds as agonists or antagonists of receptors or ion channels or other such cell surface protein. Test compounds of interest are synthesized on the beads or linked thereto, the identity of the linked compounds is encoded in the memory either during or following synthesis, linkage or coating. The scintillating matrices with memories are then incubated with radiolabeled [<sup>125</sup>I, <sup>3</sup>H, or other suitable radiolabel] receptor of interest and counted in a liquid scintillation counter. When radiolabeled receptor binds to any of the structure(s) synthesized or linked to the bead, the radioisotope is in sufficient proximity to the bead to stimulate the scintillant to emit light. In contrast By contrast, if a receptor does not bind, less or no radioactivity is associated with the bead, and consequently less light is emitted. Thus, at equilibrium, the presence of molecules that are able to bind the receptor may be detected. When the reading is completed, the memory in each bead that emits light [or more light than a control] queried and the host computer, decoder/encoder, or scanner can interpret the memory in the bead and identify the active ligand.

**(a) Multi-ligand assay**

Mixtures of scintillating matrices with memories with a variety of linked ligands, which were synthesized on the matrices or linked thereto and their identities encoded in each memory, are incubated with a single receptor. The memory in each light-emitting scintillating matrix with memory is queried and the identity of the binding ligand is determined.

**(b) Multi-receptor assays**

Similar to conventional indirect or competitive receptor binding assays that are based on the competition between unlabelled ligand and a fixed quantity of radiolabeled ligand for a limited number of binding sites,

-109-

the scintillating matrices with memories permit the simultaneous screening of a number of ligands for a number of receptor subtypes.

Mixtures of receptor coated beads [one receptor type/per bead; each memory encoded with the identity of the linked receptor] are  
5 reacted with labeled ligands specific for each receptor. After the reaction has reached equilibrium, all beads that emit light are reacted with a test compound. Beads that no longer emit light are read.

For example receptor isoforms, such as retinoic acid receptor isoforms, are each linked to a different batch of scintillating matrix with  
10 memory beads, and the identity of each isoform is encoded in the memories of linked matrices. After addition of the radiolabeled ligand(s), such as <sup>3</sup>H-retinoic acid, a sample of test compounds [natural, synthetic, combinatorial, etc.] is added to the reaction mixture, mixed and incubated for sufficient time to allow the reaction to reach equilibrium.  
15 The radiolabeled ligand binds to its receptor, which has been covalently linked to the bead and which the emitted short range electrons will excite the fluophor or scintillant in the beads, producing light. When unlabelled ligand from test mixture is added, if it displaces the labeled ligand it will diminish or stop the fluorescent light signal. At the end of incubation  
20 period, the tube can be measured in a liquid scintillation counter to demonstrate if any of the test material reacted with receptor family. Positive samples [reduced or no fluorescence] will be further analyzed for receptor subtyping by querying their memories with the RF detector. In preferred embodiments, each bead will be read and with a fluorescence  
25 detector and RF scanner. Those that have a reduced fluorescent signal will be identified and the linked receptor determined by the results from querying the memory.

The same concept can be used to screen for ligands for a number of receptors. In one example, FGF receptor, EGF receptor, and PDGF  
30 receptor are each covalently linked to a different batch of scintillating

-110-

matrix with memory beads. The identity of each receptor is encoded in each memory. After addition of the  $^{125}\text{I}$ -ligands [ $^{125}\text{I}$ -FGF,  $^{125}\text{I}$ -EGF, and  $^{125}\text{I}$ -PDGF] a sample of test compounds [natural, synthetic, combinatorial, etc.] is added to the tube containing  $^{125}\text{I}$ -ligand-receptor-beads, mixed and incubated for sufficient time to allow the reaction to reach equilibrium. The radiolabeled ligands bind to their respective receptors receptor that been covalently linked to the bead. By virtue of proximity of the label to the bead, the emitted short range electrons will excite the fluophor in the beads. When unlabelled ligand from test mixture is added, if it displaces the any of the labeled ligand it will diminish or stop the fluorescent signal. At the end of incubation period, the tube can be measured in a liquid scintillation counter to demonstrate if any of the test material reacted with the selected receptor family. Positive samples will be further analyzed for receptor type by passing the resulting complexes measuring the fluorescence of each bead and querying the memories by exposing them to RF or the selected EM radiation. The specificity of test ligand is determined by identifying beads with reduced fluorescence that and determining the identity of the linked receptor by querying the memory.

20

**(c) Other formats**

Microspheres, generally polystyrene typically about  $0.3\ \mu\text{m}$  -  $3.9\ \mu\text{m}$ , are synthesized with scintillant inside can either be purchased or prepared by covalently linking scintillant to the monomer prior to polymerization of the polystyrene or other material. They can then be derivatized [or purchased with with chemical functional groups], such as  $\text{COOH}$ , and  $-\text{CH}_2\text{OH}$ . Selected compounds or libraries are synthesized on the resulting microspheres linked via the functional groups, as described herein, or receptor, such as radiolabeled receptor, can be coated on the microsphere. The resulting "bead" with linked compounds, can used in a variety of SPA and related assays, including immunoassays,

30



-111-

receptor binding assays, protein:protein interaction assays, and other such assays in which the ligands linked to the scintillant-containing microspheres are reacted with memories with matrices that are coated with a selected receptor.

5 For example,  $^{125}\text{I}$ -labeled receptor is passively coated on the memory with matrix and then mixed with ligand that is linked to a the scintillant-containing microspheres. Upon binding the radioisotope into is brought into close proximity to the scintillant in which effective energy transfer from the  $\beta$  particle will occur, resulting in emission of light.

10 Alternatively, the memory with matrix [containing scintillant] can also be coated with  $^3\text{H}$ -containing polyer on which the biological target [i.e., receptor, protein, antibody, antigen] can be linked [via adsorption or via a functional group]. Binding of the ligand brings the scintillant into close proximity to the label, resulting in light emission.

15 **(2) Cell-based Assays**

Cell-based assays, which are fundamental for understanding of the biochemical events in cells, have been used with increasing frequency in biology, pharmacology, toxicology, genetics, and oncology [see, e.g., Benjamin et al. (1992) Mol. Cell. Biol. 12:2730-2738]. Such cell lines  
20 may be constructed or purchased [see, e.g., the Pro-Tox Kit available from Xenometrix, Boulder CO; see, also International PCT Application No. WO 94/7208 cell lines]. Established cell lines, primary cell culture, reporter gene systems in recombinant cells, cells transfected with gene of interest, and recombinant mammalian cell lines have been used to set up  
25 cell-based assays. For example Xenometrix, Inc. [Boulder, CO.] provides kits for screening compounds for toxicological endpoints and metabolic profiles using bacteria and human cell lines. Screening is effected by assessing activation of regulatory elements of stress genes fused to reporter genes in bacteria, human liver or colon cell lines and provide  
30 information on the cytotoxicity and permeability of test compounds.

-112-

In any drug discovery program, cell-based assays offer a broad range of potential targets as well as information on cytotoxicity and permeability. The ability to test large numbers of compounds quickly and efficiently provides a competitive advantage in pharmaceutical lead  
5 identification.

High throughput screening with cell-based assays is often limited by the need to use separation, wash, and disruptive processes that compromise the functional integrity of the cells and performance of the assay. Homogeneous or mix-and-measure type assays simplify  
10 investigation of various biochemical events in whole cells and have been developed using scintillation microplates [see, e.g., International PCT Application No. WO 94/26413, which describes scintillant plates that are adapted for attachment and/or growth of cells and proximity assays using such cells]. In certain embodiment herein, cell lines such as those  
15 described in International PCT Application No. WO 94/17208 are be plated on scintillant plates, and screened against compounds synthesized on matrices with memories. Matrices with memories encoded with the identity of the linked molecule will be introduced into the plates, the linkages cleaved and the effects of the compounds assessed. Positive  
20 compounds will be identified by querying the associated memory.

The scintillant base plate is preferably optically transparent to selected wavelengths that allow cells in culture to be viewed using an inverted phase contrast microscope, and permit the material to transmit light at a given wavelength with maximum efficiency. In addition the  
25 base retains its optical properties even after exposure to incident beta radiation from radioisotopes as well as under stringent radiation conditions required for sterilization of the plates. The base plate can be composed of any such optically transparent material containing scintillant, e.g., a scintillant glass based on lanthanide metal compounds. Typically,  
30 the base plate is composed of any plastic material, generally formed from

-113-

monomer units that include phenyl or naphthyl moieties in order to absorb incident radiation energy from radionuclides which are in close proximity with the surface. Preferably the plastic base plate is composed of polystyrene or polyvinyltoluene, into which the scintillant is incorporated.

- 5 The scintillant includes, but is not limited to: aromatic hydrocarbons such as p-terphenyl, p-quaterphenyl and their derivatives, as well as derivatives of the oxazoles and 1,3,4-oxadiazoles, such as 2-(4-t-butylphenyl)-5-(4-biphenyl)-1,3,4-oxadiazole and 2,5-diphenyloxazole. Also included in the polymeric composition may be a wavelength shifter such as 1,4-bis(5-  
10 phenyl-2-oxazolyl)benzene, 9,10-diphenylanthracene, 1,4-bis(2-methylstyryl)-benzene, and other such compounds. The function of the wavelength shifter is to absorb the light emitted by the scintillant substance and re-emit longer wavelength light which is a better match to the photo-sensitive detectors used in scintillation counters. Other  
15 scintillant substances and polymer bodies containing them are known to those of skill in this art [see, e.g., European Patent Application No. 0 556 005 A1].

- The scintillant substances can be incorporated into the plastic material of the base by a variety of methods. For example, the  
20 scintillators may be dissolved into the monomer mix prior to polymerization, so that they are distributed evenly throughout the resultant polymer. Alternatively the scintillant substances may be dissolved in a solution of the polymer and the solvent removed to leave a homogeneous mixture. The base plate of disc may be bonded to the  
25 main body of the well or array of wells, which itself may be composed of a plastic material including polystyrene, polyvinyltoluene, or other such polymers. In the case of the multi-well array, the body of the plate may be made opaque, i.e., non-transparent and internally reflective, in order to completely exclude transmission of light and hence minimize "cross-talk."  
30 This is accomplished by incorporating into the plastic at the

-114-

polymerization stage a white dye or pigment, for example, titanium dioxide. Bonding of the base plate to the main body of the device can be accomplished by any suitable bonding technique, for example, heat welding, injection molding or ultrasonic welding.

- 5 For example, a 96-well plate is constructed to the standard dimensions of 96-well microtiter plates 12.8 cm x 8.6 cm x 1.45 cm with wells in an array of 8 rows of 12 wells each. The main body of the plate is constructed by injection molding of polystyrene containing a loading of white titanium oxide pigment at 12%. At this stage, the wells of the
- 10 microtiter plate are cylindrical tubes with no closed end. A base plate is formed by injection molding of polystyrene containing 2-(4-t-butylphenyl)-5-(4-biphenyl)-1,3,4-oxadiazole (2%) and 9,10-diphenylanthracene (0.5%). The base plate has been silk screen printed with a grid array to further reduce crosstalk. The base plate is then fused in a separate
- 15 operation to the body by ultrasonic welding, such that the grid array overlies the portions of the microtiter plate between the wells.

- A 24-well device is constructed to the dimensions 12.8 x 8.6 x 1.4 cm with 24 wells in an array of 4 rows of 6 wells. The main body of the plate [not including the base of each well] is constructed by injection
- 20 molding of polystyrene containing 12% white titanium oxide pigment. The base 24 of each well is injection molded with polystyrene containing 2-(4-t-butylphenyl)-5-(4-biphenyl)-1,3,4-oxadizaole [2%] and 9,10-diphenylanthracene [0.5%]. The heat from the injected base plastic results in fusion to the main body giving an optically transparent base to
- 25 the well.

- The plates may contain multiple wells that are continuous or that are each discontinuous from the other wells in the array, or they may be single vessels that have, for example, an open top, side walls and an optically transparent scintillant plastic base sealed around the lower edge
- 30 of the side walls.

-115-

In another format the plate, is a single well or tube. The tube may be constructed from a hollow cylinder made from optically transparent plastic material and a circular, scintillant containing, plastic disc. The two components are welded together so as to form a single well or tube

5 suitable for growing cells in culture. As in the plate format, bonding of the circular base plate to the cylindrical portion is achieved by any conventional bonding technique, such as ultrasonic welding. The single well or tube may be any convenient size, suitable for scintillation counting. In use, the single well may either be counted as an insert in a

10 scintillation vial, or alternatively as an insert in a scintillation vial, or alternatively as an insert in a multi-well plate of a flat bed scintillation counter. In this latter case, the main body of the multi-well plate would need to be opaque for reasons given earlier.

The various formats are selected according to use. They may be

15 used for growing cells and studying cellular biochemical processes in living cells or cell fragments. The 96-well plate is a standard format used in experimental cell biology and one that is suitable for use in a flat bed scintillation counter [e.g., Wallac Microbeta or Packard Top Count]. In the multi-well format, it is an advantage to be able to prevent "cross talk"

20 between different wells of the plate that may be used for monitoring different biological processes using different amounts or types of radioisotope. Therefore the main body of the plate can be made from opaque plastic material. The 24-well plate format is commonly used for cell culture. This type of plate is also suitable for counting in a flat bed

25 scintillation counter. The dimensions of the wells will be larger.

As an alternative format, the transparent, scintillant containing plastic disc is made to be of suitable dimensions so as to fit into the bottom of a counting vessel. The counting vessel is made from non-scintillant containing material such as glass or plastic and should be

30 sterile in order to allow cells to grow and the corresponding cellular

-116-

metabolic processes to continue. Cells are first cultured on the disc, which is then transferred to the counting vessel for the purposes of monitoring cellular biochemical processes.

The culture of cells on the scintillation plastic base plate of the  
5 wells (or the disc) involves the use of standard cell culture procedures, e.g., cells are cultured in a sterile environment at 37° C in an incubator containing a humidified 95% air/5% CO<sub>2</sub> atmosphere. Various cell culture media may be used including media containing undefined biological fluids such as fetal calf serum, or media which is fully defined  
10 and serum-free. For example, MCDB 153 is a selective medium for the culture of human keratinocytes [Tsao et al. (1982) J. Cell. Physiol. 110:219-229].

These plates are suitable for use with any adherent cell type that can be cultured on standard tissue culture plasticware, including culture  
15 of primary cells, normal and transformed cells derived from recognized sources species and tissue sources. In addition, cells that have been transfected with the recombinant genes may also be cultured using the invention. There are established protocols available for the culture of many of these diverse cell types [see, e.g., Freshney et al. (1987) Culture  
20 of Animal Cells: A Manual of Basic Technique, 2nd Edition, Alan R. Liss Inc.]. These protocols may require the use of specialized coatings and selective media to enable cell growth and the expression of specialized cellular functions.

The scintillating base plate or disc, like all plastic tissue culture  
25 ware, requires surface modification in order to be adapted for the attachment and/or growth of cells. Treatment can involve the use of high voltage plasma discharge, a well established method for creating a negatively charged plastic surface [see, e.g., Amstein et al. (1975) J. Clinical Microbiol. 2:46-54]. Cell attachment, growth and the expression  
30 of specialized functions can be further improved by applying a range of

-117-

additional coatings to the culture surface of the device. These can include: (i) positively or negatively charged chemical coatings such as poly-lysine or other biopolymers [McKeehan *et al.* (1976) *J. Cell Biol.* 71:727-734 (1976)]; (ii) components of the extracellular matrix including  
5 collagen, laminin, fibronectin [ see, *e.g.*, Kleinman *et al.* (1987) *Anal. Biochem.* 166:1-13]; and (iii) naturally secreted extracellular matrix laid down by cells cultured on the plastic surface [ Freshney *et al.* *et al.* (1987) *Culture of Animal Cells: A Manual of Basic Technique*, 2nd Edition, Alan R. Liss Inc.]. Furthermore, the scintillating base plate may  
10 be coated with agents, such as lectins, or adhesion molecules for attachment of cell membranes or cell types that normally grow in suspension. Methods for the coating of plasticware with such agents are known [see, *e.g.*, Boldt *et al.* (1979) *J. Immunol.* 123:808].

In addition, the surface of the scintillating layer may be coated with  
15 living or dead cells, cellular material, or other coatings of biological relevance. The interaction of radiolabeled living cells, or other structures with this layer can be monitored with time allowing processes such as binding, movement to or from or through the layer to be measured.

Virtually all types of biological molecules can be studied. A any  
20 molecule or complex of molecules that interact with the cell surface or that can be taken up, transported and metabolized by the cells, can be examined using real time analysis. Examples of biomolecules will include receptor ligands, protein and lipid metabolite precursors (*e.g.*, amino acids, fatty acids), nucleosides and any molecule that can be  
25 radiolabeled. This would also include ions such as calcium, potassium, sodium and chloride, that are functionally important in cellular homeostasis, and which exist as radioactive isotopes. Furthermore, viruses and bacteria and other cell types, which can be radiolabeled as intact moieties, can be examined for their interaction with monolayer  
30 adherent cells grown in the scintillant well format.

-118-

The type of radioactive isotope that can be used with this system will typically include any of the group of isotopes that emit electrons having a mean range up to 2000  $\mu\text{m}$  in aqueous medium. These will include isotopes commonly used in biochemistry such as [ $^3\text{H}$ ], [ $^{125}\text{I}$ ], [ $^{14}\text{C}$ ],

5 [ $^{35}\text{S}$ ], [ $^{45}\text{Ca}$ ], [ $^{33}\text{P}$ ], and [ $^{32}\text{P}$ ], but does not preclude the use of other isotopes, such as [ $^{55}\text{Fe}$ ], [ $^{109}\text{Cd}$ ] and [ $^{51}\text{Cr}$ ] that also emit electrons within this range. The wide utility of the invention for isotopes of different emission energy is due to the fact that the current formats envisaged would allow changes to the thickness of the layer containing a scintillant

10 substance, thereby ensuring that all the electron energy is absorbed by the scintillant substance. Furthermore, cross-talk correction software is available which can be utilized with all high energy emitters. Applications using these plates include protein synthesis,  $\text{Ca}^{2+}$  transport, receptor-ligand binding, cell adhesion, sugar transport and metabolism, hormonal

15 stimulation, growth factor regulation and stimulation of motility, thymidine transport, and protein synthesis.

For use in accord with the methods herein, the scintillant plates can include a memory in each well, or alternatively, memory with matrix-linked compounds will be added to each well. The recording device with

20 memory may be impregnated or encased or placed in wells of the plate, typically during manufacture. In preferred embodiments, however, the memories are added to the wells with adsorbed or linked molecules.

In one embodiment, matrices with memories with linked molecules are introduced into scintillant plates in which cells have been cultured

25 [see, e.g., International PCT Application No. WO 94/26413]. For example, cells will be plated on the transparent scintillant base 96-well microplate that permits examination of cells in culture by inverted phase contrast microscope and permits the material to transmit light at a given wavelength with maximum efficiency. Matrices with memories to which

30 test compounds linked by preferably a photocleaveable linker are added to



-119-

the wells. The identity of each test compound is encoded in the memory of the matrix during synthesis if the compound is synthesized on the matrix with memory or when the compound is linked to the matrix.

Following addition of matrix with memory to the well and release  
5 of chemical entities synthesized on the beads by exposure to light or other procedures, the effects of the chemical released from the beads on the selected biochemical events, such as signal transduction, cell proliferation, protein or DNA synthesis, in the cells can be assessed. In this format receptor binding Such events include, but are not limited to:  
10 whole cell receptor-ligand binding [agonist or antagonist], thymidine or uridine transport, protein synthesis (using, for example, labeled cysteine, methionine, leucine or proline), hormone and growth factor induced stimulation and motility, and calcium uptake.

In another embodiment, the memories are included in the plates  
15 either placed in the plates or manufactured in the wells of the plates. In these formats, the identities of the contents of the well is encoded into the memory. Of course it is understood, that the information encoded and selection of encased or added memories depends upon the selected protocol.

20 In another format, cells will be plated on the tissue culture plate, after transferring the matrices with memories and release of compounds synthesized on the beads in the well. Cytostatic, cytotoxic and proliferative effects of the compounds will be measured using colorimetric [MTT, XTT, MTS, Alamar blue, and Sulforhodamine B], fluorimetric  
25 [carboxyfluorescein diacetate] , or chemiluminescent reagents [*i.e.*, CytoLite™, Packard Instruments, which is used in a homogeneous luminescent assay for cell proliferation, cell toxicity and multi-drug resistance].

For example, cells that have been stably or transiently transfected  
30 with a specific gene reporter construct containing an inducible promoter

-120-

operatively linked to a reporter gene that encodes an indicator protein can be colorimetrically monitored for promoter induction. Cells will be plated on the tissue culture 96-well microtiter plate and after addition of memories with matrices in the wells and release of chemical entities

5 synthesized on the matrices, the effect of the compound released from the beads on the gene expression will be assessed. The Cytosensor Microphysiometer [Molecular Devices] evaluates cellular responses that are mediated by G protein-linked receptors, tyrosine kinase-linked receptors, and ligand-gated ion channels. It measures extracellular pH to

10 assess profiles of compounds assessed for the ability to modulate activities of any of the these cell surface proteins by detecting secretion of acid metabolites as a result of altered metabolic states, particularly changes in metabolic rate. Receptor activation requires use of ATP and other energy resources of the cell thereby leading to increased in cellular

15 metabolic rate. For embodiments herein, the memories with matrices, particularly those modified for measuring pH, and including linked test compounds, can be used to track and identify the added test compound added and also to detect changes in pH, thereby identifying linked molecules that modulate receptor activities.

20                   **3. Memories with matrices for non-radioactive energy transfer proximity assays**

Non-radioactive energy transfer reactions, such as FET or FRET, FP and HTRF assays, are homogeneous luminescence assays based on energy transfer are carried out between a donor luminescent label and an

25 acceptor label [see, e.g., Cardullo et al. (1988) Proc. Natl. Acad. Sci. U.S.A. 85:8790-8794; Pearce et al. (1986) Proc. Natl. Acad. Sci. U.S.A. 83:8092-8096; U.S. Patent No. 4,777,128; U.S. Patent No. 5,162,508; U.S. Patent No. 4,927,923; U.S. Patent No. 5,279,943; and International PCT Application No. WO 92/01225]. The donor label is usually a rare

30 earth metal cryptate, particularly europium trisbipyridine diamine [EuTBP]

-121-

or terbium trisbipyridine diamine [TbTBP] and an acceptor luminescent, presently fluorescent, label. When the donor is EuTBP, the acceptor is preferably allophycocyanin [APC], allophycocyanin B, phycocyanin C or phycocyanin R, and when the donor is TbTBP, the acceptor is a

5 rhodamine, thiomine, phycocyanin R, phycoerythrocyanin, phycoerythrin C, phycoerythrin B or phycoerythrin R.

Energy transfer between such donors and acceptors is highly efficient, giving an amplified signal and thereby improving the precision and sensitivity of the assay. Within distances characteristic of

10 interactions between biological molecules, the excitation of a fluorescent label (donor) is transferred non radiatively to a second fluorescent label (acceptor). When using europium cryptate as the donor, APC, a phycobiliprotein of 5 kDa, is presently the preferred acceptor because it has high molar absorptivity at the cryptate emission wavelength providing

15 a high transfer efficiency, emission in a spectral range in which the cryptate signal is insignificant, emission that is not quenched by presence of sera, and a high quantum yield. When using  $\text{Eu}^{3+}$  cryptate as donor, an amplification of emitted fluorescence is obtained by measuring APC emission.

20 The rare earth cryptates are formed by the inclusion of a luminescence lanthanide ion in the cavity of a macropolycyclic ligand containing 2,2'-bipyridine groups as light absorbers [see, e.g., U.S. Patent No. 5,162,508; U.S. Patent No. 4,927,923; U.S. Patent No. 5,279,943; and International PCT Application No. WO 92/01225].

25 Preferably the  $\text{Eu}^{3+}$  trisbipyridine diamine derivative, although the acceptor may be used as the label, is cross-linked to antigens, antibodies, proteins, peptides, and oligonucleotides and other molecules of interest.

For use herein, matrices with memories are prepared that incorporate either the donor or, preferably the acceptor, into or on the

30 matrix. In practice, as with the scintillating matrices with memories, the

-122-

matrices may be of any format, i.e. particulate, or continuous, and used in any assay described above for the scintillating matrices. For example, the recording device is coated with a protective coating, such as glass or polystyrene. If glass it can be etched. As with preparation of the

5 scintillating matrices with memories, compositions containing the donor or preferably acceptor, such as APC, and typically a polymer or gel, are coated on the recording device or the device is mixed with the composition to produce a fluorescing matrix with memory. To make these matrices resistant to chemical reaction, if needed, they may be

10 coated with polymers such as polyvinylbenzene or polystyrene. Molecules, such as the constituents of combinatorial libraries, are synthesized on the fluorescing matrices with memories, or molecules or biological particles are linked thereto, the identity of the synthesized molecules or linked molecules or biological particles is encoded in

15 memory, and the resulting matrices with memories employed in any suitable assay, including any of those described for the scintillating memories with matrices. In particular, these homogeneous assays using long-lived fluorescence rare earth cryptates and amplification by non radiative energy transfer have been adapted to use in numerous assays

20 including assays employing ligand receptor interaction, signal transduction, transcription factors (protein-protein interaction), enzyme substrate assays and DNA hybridization and analysis [see, Nowak (1993) Science 270:368; see, also, Velculescu et al. (1995) Science 270:484-487, and Schena et al. (1995) Science 270:467-470, which describe

25 methods quantitative and simultaneous analysis of a large number of transcripts that are particularly suited for modification using matrices with memories]. Each of these assays may be modified using the fluorescing matrices with memories provided herein.

For example, a receptor will be labeled with a europium cryptate

30 [where the matrices with memories incorporate, for example

-123-

allophycocyanin (APC)] or will be labeled with APC, where the matrices incorporate a europium cryptate. After mixing receptor and mixtures of matrices with different ligands, the mixture is exposed to laser excitation at 337 nm, and, if reaction has occurred, typical signals of europium  
5 cryptate and APC over background are emitted. Measurement with an interference filter centered at 665 nm selects the signal of the APC labeled receptor from that of europium cryptate labeled ligand on the beads. If particulate, the memories of matrices that emit at 665, can be queried to identify linked ligands.

- 10                   4.     **Other applications using memories with matrices and luminescing memories with matrices**  
                      a.     **Natural product screening**

In the past, the vast majority of mainline pharmaceuticals have been isolated from natural products such as plants, bacteria, fungus, and  
15 marine microorganisms. Natural products include microbials, botanicals, animal and marine products. Extracts of such sources are screened for desired activities and products. Selected products include enzymes [e.g., hyaluronidase], industrial chemicals [e.g., petroleum emulsifying agents], and antibiotics [e.g., penicillin]. It is generally considered that a wealth of  
20 new agents still exist within the natural products pool. Large mixtures of natural products, even within a fermentation broth, can be screened using the matrices with memory combinations linked, for example, to peptides, such as antigens or antibody fragments or receptors, of selected and known sequences or specificities, or to other biologically active  
25 compounds, such as neurotransmitters, cell surface receptors, enzymes, or any other identified biological target of interest. Mixtures of these peptides linked to memory matrices can be introduced into the natural product mixture. Individual binding matrices, detected by an indicator, such as a fluorometric dye, can be isolated and the memory queried to

-124-

determine which linked molecule or biological particle is bound to a natural product.

**b. Immunoassays and immunodiagnostics**

The combinations and methods provided herein represent major  
5 advances in immunodiagnostics. Immunoassays [such as ELISAs, RIAs  
and EIAs (enzyme immunoassays)] are used to detect and quantify  
antigens or antibodies.

**(1) Immunoassays**

Immunoassays detect or quantify very small concentrations of  
10 analytes in biological samples. Many immunoassays use solid supports in  
which antigen or antibody is covalently, non-covalently, or otherwise,  
such as via a linker, attached to a solid support matrix. The support-  
bound antigen or antibody is then used as an analyte in the assay. As  
with nucleic acid analysis, the resulting antibody-antigen complexes or  
15 other complexes, depending upon the format used, rely on radiolabels or  
enzyme labels to detect such complexes.

The use of antibodies to detect and/or quantitate reagents  
["antigens"] in blood or other body fluids has been widely practiced for  
many years. Two methods have been most broadly adopted. The first  
20 such procedure is the competitive binding assay, in which conditions of  
limiting antibody are established such that only a fraction [usually 30-  
50%] of a labeled [e.g., radioisotope, fluophore or enzyme] antigen can  
bind to the amount of antibody in the assay medium. Under those condi-  
tions, the addition of unlabeled antigen [e.g., in a serum sample to be  
25 tested] then competes with the labeled antigen for the limiting antibody  
binding sites and reduces the amount of labeled antigen that can bind.  
The degree to which the labeled antigen is able to bind is inversely  
proportional to the amount of unlabeled antigen present. By separating  
the antibody-bound from the unbound labeled antigen and then

-125-

determining the amount of labeled reagent present, the amount of unlabeled antigen in the sample [e.g., serum] can be determined.

As an alternative to the competitive binding assay, in the labeled antibody; or "immunometric" assay [also known as "sandwich" assay],  
5 an antigen present in the assay fluid is specifically bound to a solid substrate and the amount of antigen bound is then detected by a labeled antibody [see, e.g., Miles *et al.* (1968) *Nature* 29:186-189; U.S. Patent No. 3,867,517; U.S. Patent No. 4,376,110]. Using monoclonal antibodies two-site immunometric assays are available [see, e.g., U.S.  
10 Patent No. 4,376,110]. The "sandwich" assay has been broadly adopted in clinical medicine. With increasing interest in "panels" of diagnostic tests, in which a number of different antigens in a fluid are measured, the need to carry out each immunoassay separately becomes a serious limitation of current quantitative assay technology.

15 Some semi-quantitative detection systems have been developed [see, e.g., Buechler *et al.* (1992) *Clin. Chem.* 38:1678-1684; and U.S. Patent No. 5,089,391] for use with immunoassays, but no good technologies yet exist to carefully quantitate a large number of analytes simultaneously [see, e.g., Ekins *et al.* (1990) *J. Clin. Immunoassay*  
20 13:169-181] or to rapidly and conveniently track, identify and quantitate detected analytes.

The methods and memories with matrices provided herein provide a means to quantitate a large number of analytes simultaneously and to rapidly and conveniently track, identify and quantitate detected analytes.

25 **(2) Multianalyte immunoassays**

The combinations of matrix with memories provided herein permits the simultaneous assay of large numbers of analytes in any format. In general, the sample that contains an analyte, such as a ligand or any substance of interest, to be detected or quantitated, is incubated with  
30 and bound to a protein, such as receptor or antibody, or nucleic acid or

-126-

other molecule to which the analyte of interest binds. In one embodiment, the protein or nucleic acid or other molecule to which the analyte of interest binds has been linked to a matrix with memory prior to incubation; in another embodiment, complex of analyte or ligand and  
5 protein, nucleic acid or other molecule to which the analyte of interest binds is linked to the matrix with memory after the incubation; and in a third embodiment, incubation to form complexes and attachment of the complexes to the matrix with memory are simultaneous. In any embodiment, attachment is effected, for example, by direct covalent  
10 attachment, by kinetically inert attachment, by noncovalent linkage, or by indirect linkage, such as through a second binding reaction [*i.e.*, biotin-avidin, Protein A-antibody, antibody-hapten, hybridization to form nucleic acid duplexes of oligonucleotides, and other such reactions and interactions]. The complexes are detected and quantitated on the solid  
15 phase by virtue of a label, such as radiolabel, fluorescent label, luminophore label, enzyme label or any other such label. The information that is encoded in the matrix with memory depends upon the selected embodiment. If, for example, the target molecule, such as the protein or receptor is bound to the solid phase, prior to complexation, the identity of  
20 the receptor and/or source of the receptor may be encoded in the memory in the matrix.

For example, the combinations provided herein are particularly suitable for analyses of multianalytes in a fluid, and particularly for multianalyte immunoassays. In one example, monoclonal antibodies very  
25 specific for carcinoembryonic antigen [CEA], prostate specific antigen [PSA], CA-125, alphafetoprotein [AFP], TGF- $\beta$ , IL-2, IL-8 and IL-10 are each covalently attached to a different batch of matrices with memories using well-established procedures and matrices for solid phase antibody assays. Each antibody-matrix with memory complex is given a specific  
30 identification tag, as described herein.



-127-

A sample of serum from a patient to be screened for the presence or concentration of these antigens is added to a tube containing two of each antibody-matrix with memory complex [a total of 16 beads, or duplicates of each kind of bead]. A mixture of monoclonal antibodies, previously conjugated to fluorescent dyes, such as fluorescein or phenyl-EDTA-Eu chelate, reactive with different epitopes on each of the antigens is then added. The tubes are then sealed and the contents are mixed for sufficient time [typically one hour] to allow any antigens present to bind to their specific antibody-matrix with memory-antigen complex to produce antibody-matrix with memory-antigen-labeled antibody complexes. At the end of the time period, these resulting complexes are briefly rinsed and passed through an apparatus, such as that set forth in FIGURE 7, but with an additional light source. As each complex passes through a light source, such as a laser emitting at the excitation wavelength of fluorescein, about 494 nm, or 340 nm for the Eu chelate complex, its fluorescence is measured and quantitated by reading the emitted photons at about 518 nm for fluorescein or 613 nm for phenyl-EDTA-Eu, and as its identity is determined by the specific signal received by the RF detector. In this manner, eight different antigens are simultaneously detected and quantitated in duplicate.

In another embodiment, the electromagnetically tagged matrices with recorded information regarding linked antibodies can be used with other multianalyte assays, such as those described by Ekins *et al.* [(1990) *J. Clin. Immunoassay* 13:169-181; see, also International PCT Applications Nos. 89/01157 and 93/08472, and U.S. Patent Nos. 4,745,072, 5,171,695 and 5,304,498]. These methods rely on the use of small concentrations of sensor-antibodies within a few  $\mu\text{m}^2$  area. Individual memories with matrices, or an array of memories embedded in a matrix are used. Different antibodies are linked to each memory, which is programmed to record the identity of the linked antibody.

-128-

Alternatively, the antibody can be linked, and its identity or binding sites identified, and the information recorded in the memory. Linkage of the antibodies can be effected by any method known to those of skill in this art, but is preferably effected using cobalt-iminodiacetate coated

5 memories [see, Hale (1995) Analytical Biochem. 231:46-49, which describes means for immobilization of antibodies to cobalt-iminodiacetate resin] mediated linkage particularly advantageous. Antibodies that are reversibly bound to a cobalt-iminodiacetate resin are attached in exchange

10 insert manner when the cobalt is oxidized from the +2 to +3 state. In this state the antibodies are not removed by metal chelating reagents, high salt, detergents or chaotropic agents. They are only removed by reducing agents. In addition, since the metal binding site in antibodies is in the C-terminus heavy chain, antibodies so-bound are oriented with the combining site directed away from the resin.

15 In particular antibodies are linked to the matrices with memories. The matrices are either in particular form or in the form of a slab with an array of recording devices linked to the matrices or microtiter dish or the like with a recording device in each well. Antibodies are then linked

20 either to each matrix particle or to discrete "microspots" on the slab or in the microtiter wells. In one application, prior to use of these matrices with memories, they are bound to a relatively low affinity anti-idiotypic antibody [or other species that specifically recognizes the antibody binding site, such as a single chain antibody or peptidomimetic] labeled with a fluorophore [e.g., Texas Red, see, Ekins et al. (1990) J. Clin.

25 Immunoassay 13:169-181] to measure the concentration of and number of available binding sites present on each matrix with memory particle or each microspot, which information is then encoded into each memory for each microspot or each particle. These low affinity antibodies are then eluted, and the matrices can be dried and stored until used.

-129-

Alternatively or additionally, the memories in the particles or at each microspot could be programmed with the identity or specificity of the linked antibody, so that after reaction with the test sample and identification of complexed antibodies, the presence and concentration of particular analytes in the sample can be determined. They can be used for multianalyte analyses as described above.

After reaction with the test sample, the matrices with memories are reacted with a second antibody, preferably, although not necessarily, labeled with a different label, such as a different fluophore, such as fluorescein. After this incubation, the microspots or each matrix particle is read by passing the particle through a laser scanner [such as a confocal microscope, see, e.g., Ekins *et al.* (1990) *J. Clin. Immunoassay* 13:169-181; see also U.S. Patent No. 5,342,633] to determine the fluorescence intensity. The memories at each spot or linked to each particle are queried to determine the total number of available binding sites, thereby permitting calculation of the ratio of occupied to unoccupied binding sites.

Equilibrium dialysis and modifications thereof has been used to study the interaction of antibody or receptor or other protein or nucleic acid with low molecular weight dialyzable molecules that bind to the antibody or receptor or other protein or nucleic acid. For applications herein, the antibody, receptor, protein or nucleic acid is linked to solid support (matrix with memory) and is incubated with the ligand.

In particular, this method may be used for analysis of multiple binding agents [receptors], linked to matrices with memories, that compete for available ligand, which is present in limiting concentration. After reaction, the matrices with memories linked to the binding agents [receptors] with the greatest amount of bound ligand, are the binding agents [receptors] that have the greatest affinity for the ligand.

-130-

The use of matrices with memories also permits simultaneous determination of  $K_a$  values of multiple binding agents [receptors] or have multiple ligands. For example, a low concentration of labeled ligand is mixed with a batch of different antibodies bound to matrices with

5 memories. The mixture is flowed through a reader [*i.e.*, a Coulter counter or other such instrument that reads RF and the label] could simultaneously measure the ligand [by virtue of the label] and identity of each linked binding agent [or linked ligand] as the chip is read. After the reaction equilibrium [determined by monitoring progress of the reaction]

10 labeled ligand is added and the process of reading label and the chips repeated. This process is repeated until all binding sites on the binding agent [or ligand] approach saturation, thereby permitting calculation of  $K_a$  values and binding sites that were available.

15 **c. Selection of antibodies and other screening methods**

**(1) Antibody selection**

In hybridoma preparation and selection, fused cells are plated into, for example, microtiter wells with the matrices with memory-tagged antibody binding reagent [such as protein A or Co-chelate [see, *e.g.*,

20 Smith *et al.* (1992) Methods: A Companion to Methods in Enzymology 4, 73 (1992); Ill *et al.* (1993) Biophys J. 64:919; Loetscher *et al.* (1992) J. Chromatography 595:113-199; U.S. Patent No. 5,443,816; Hale (1995) Analytical Biochem. 231:46-49 ]. The solid phase is removed, pooled and processed batchwise to identify the cells that produce antibodies that

25 are the greatest binders [see, *e.g.*, U.S. Patent No. 5,324,633 for methods and device for measuring the binding affinity of a receptor to a ligand; or the above method by which phage libraries are screened for highest  $K_A$  phage, *i.e.*, limiting labeled antigen].

-131-

## (2) Antibody panning

Memories with matrices with antibody attached thereto [e.g. particularly embodiments in which the matrix is a plate] may be used in antibody panning [see, e.g., Wysocki *et al.* (1978) Proc. Natl. Acad. Sci. U.S.A. 75:2844-48; Basch *et al.* (1983) J. Immunol. Methods 56:269; Thiele *et al.* (1986) J. Immunol. 136:1038-1048; Mage *et al.* (1981) Eur. J. Immunol. 11:226; Mage *et al.* (1977) J. Immunol. Methods 15:47-56; see, also, U.S. Patent Nos. 5,217,870 and 5,087,570, for descriptions of the panning method]. Antibody panning was developed as a means to fractionate lymphocytes on the basis of surface phenotype based on the ability of antibody molecules to adsorb onto polystyrene surfaces and retain the ability to bind antigen. Originally [Wysocki *et al.* (1978) Proc. Natl. Acad. Sci. U.S.A. 75:2844-2848] polystyrene dishes coated with antibodies specific for cell surface antigens and permit cells to bind to the dishes, thereby fractionating cells. In embodiments herein, polystyrene or other suitable matrix is associated with a memory device and coated with an antibody, whose identity is recorded in the memory. Mixtures of these antibody coated memories with matrices can be mixed with cells, and multiple cell types can be sorted and identified by querying the memories to which cells have bound.

### d. Phage display

Phage, viruses, bacteria and other such manipulable hosts and vectors [referred to as biological particles] can be modified to express selected antigens [peptides or polypeptides] on their surfaces by, for example, inserting DNA encoding the antigen into the host or vector genome, at a site such as in the DNA encoding the coat protein, such that upon expression the antigen [peptide or polypeptide] is presented on the surface of the virus, phage or bacterial host. Libraries of such particles that express diverse or families of proteins on their surfaces have been prepared. The resulting library is then screened with a

-132-

targeted antigen [receptor or ligand] and those viruses with the highest affinity for the targeted antigen [receptor or ligand] are selected [see, e.g., U.S. Patent Nos. 5,403,484, 5,395,750, 5,382,513, 5,316,922, 5,288,622, 5,223,409, 5,223,408 and 5,348,867].

5 Libraries of antibodies expressed on the surfaces of such packages have been prepared from spleens of immunized and unimmunized animals and from humans. In the embodiment in which a library of phage displaying antibodies from unimmunized human spleens is prepared, it is often of interest to screen this library against a large number of different  
10 antigens to identify a number of useful human antibodies for medical applications. Phage displaying antibody binding sites derived from single or small numbers of spleen cells can be separately produced, expanded into large batches, and bound to matrices with memories, such as programmable PROM or EEPROM memories, and identified according to  
15 phage batch number recorded in the memory. Each antigen can then be exposed to a large number of different phage-containing memory devices, and those that bind the antigen can be identified by one of several means, including radiolabeled, fluorescent labeled, enzyme labeled or alternate (e.g., mouse) tagged antibody labeled antigen. The encoded  
20 information in the thus identified phage-containing devices, relates to the batch of phage reactive with the antigen.

Libraries can also be prepared that contain modified binding sites or synthetic antibodies. DNA molecules, each encoding proteins containing a family of similar potential binding domains and a structural signal calling  
25 for the display of the protein on the outer surface of a selected viral or bacterial or other package, such as a bacterial cell, bacterial spore, phage, or virus are introduced into the bacterial host, virus or phage. The protein is expressed and the potential binding domain is displayed on the outer surface of the particle. The cells or viruses bearing the binding domains  
30 to which target molecules bind are isolated and amplified, and then are

-133-

characterized. In one embodiment, one or more of these successful binding domains is used as a model for the design of a new family of potential binding domains, and the process is repeated until a novel binding domain having a desired affinity for the target molecule is

5 obtained. For example, libraries of de novo synthesized synthetic antibody library containing antibody fragments expressed on the surface have been prepared. DNA encoding synthetic antibodies, which have the structure of antibodies, specifically Fab or Fv fragments, and contain randomized binding sequences that may correspond in length to

10 hypervariable regions [CDRs] can be inserted into such vectors and screened with an antigen of choice.

Synthetic binding site libraries can be manipulated and modified for use in combinatorial type approaches in which the heavy and light chain variable regions are shuffled and exchanged between synthetic antibodies

15 in order to affect specificities and affinities. This enables the production of antibodies that bind to a selected antigen with a selected affinity. The approach of constructing synthetic single chain antibodies is directly applicable to constructing synthetic Fab fragments which can also be easily displayed and screened. The diversity of the synthetic antibody

20 libraries can be increased by altering the chain lengths of the CDRs and also by incorporating changes in the framework regions that may affect antibody affinity. In addition, alternative libraries can be generated with varying degrees of randomness or diversity by limiting the amount of degeneracy at certain positions within the CDRs. The synthetic binding

25 site can be modified further by varying the chain lengths of the CDRs and adjusting amino acids at defined positions in the CDRs or the framework region which may affect affinities. Antibodies identified from the synthetic antibody library can easily be manipulated to adjust their affinity and or effector functions. In addition, the synthetic antibody library is

30 amenable to use in other combinatorial type approaches. Also, nucleic

-134-

acid amplification techniques have made it possible to engineer humanized antibodies and to clone the immunoglobulin [antibody] repertoire of an immunized mouse from spleen cells into phage expression vectors and identify expressed antibody fragments specific to the antigen used for immunization [see, e.g., U.S. Patent No. 5,395,750].

The phage or other particles, containing libraries of modified binding sites, can be prepared in batches and linked to matrices that identify the DNA that has been inserted into the phage. The matrices are then mixed and screened with labeled antigen [e.g., fluorescent or enzymatic] or hapten, using an assay carried out with limiting quantities of the antigen, thereby selecting for higher affinity phage. Thus, libraries of phage linked to matrix particles with memories can be prepared. The matrices are encoded to identify the batch number of the phage, a sublibrary, or to identify a unique sequence of nucleotides or amino acids in the antibody or antibody fragment expressed on its surface. The library is then screened with labeled antigens. The antigens are labeled with enzyme labels or radiolabels or with the antigen bound with a second binding reagent, such as a second antibody specific for a second epitope to which a fluorescent antigen binds.

Following identification of antigen bound phage, the matrix particle can be queried and the identity of the phage or expressed surface protein or peptide determined. The resulting information represents a profile of the sequence that binds to the antigen. This information can be analyzed using methods known to those of skill in this art.

**e. Anti-microbial assays and mutagenicity assays**

Compounds are synthesized or linked to matrix with memory. The linkage is preferably a photocleavable linkage or other readily cleavable linkage. The matrices with memories with linked compounds, whose identities are programmed into each memory are the placed on, for example, 10-cm culture plates, containing different bacteria, fungi, or



-135-

other microorganism. After release of the test compounds the anti-microbial effects of the chemical will be assessed by looking for lysis or other indicia of anti-microbial activity. In preferred embodiments, arrays of memories with matrices can be introduced into plates. The memories are encoded with the identity of the linked or associated test compound and the position on the array.

The AMES test is the most widely used mutagen/carcinogen screening assay [see, e.g., Ames et al. (1975) Mutation Res. 31:347-364; Ames et al. (1973) Proc. Natl. Acad. Sci. U.S.A. 70:782-786.; Maron et al., (1983) Mutation Research 113:173; Ames (1971) in Chemical Mutagens, Principles and Methods for their Detection, Vol. 1, Plenum Press, NY, pp 267-282]. This test uses several unique strains of Salmonella typhimurium that are histidine-dependent for growth and that lack the usual DNA repair enzymes. The frequency of normal mutations that render the bacteria independent of histidine [i.e., the frequency of spontaneous revertants] is low. The test evaluates the impact of a compound on this revertant frequency. Because some substances are converted to a mutagen by metabolic action, the compound to be tested is mixed with the bacteria on agar plates along with the liver extract. The liver extract serves to mimic metabolic action in an animal. Control plates have only the bacteria and the extract. The mixtures are allowed to incubate. Growth of bacteria is checked by counting colonies. A test is positive where the number of colonies on the plates with mixtures containing a test compound significantly exceeds the number on the corresponding control plates.

-136-

A second type of Ames test [see, International PCT Application No. WO 95/10629, which is based on U.S. application Serial No. 08/011,617; and Gee *et al.* (1994) Proc. Natl. Acad. Sci. U.S.A. 91:11606-11610; commercially avail from Xenometrix, Boulder CO] is of  
 5 interest herein. This test provides a panel of Salmonella typhimurium strains for use as a detection system for mutagens that also identifies mutagenic changes. Although a direct descendant of the traditional Ames Salmonella reverse mutation assay in concept, the Ames II assay provides the means to rapidly screen for base mutations through the use  
 10 of a mixture of six different Salmonella strains.

These new strains carry *his* mutations listed in the table below. All are deleted for *uvrB* and are deficient therefore in excision repair. In addition, all six have lipopolysaccharide [*rfa*] mutations rendering them more permeable, and all contain the pKM<sup>101</sup> plasmid conferring enhanced  
 15 mutability.

| STRAIN    | BASE CHANGE | MUTATION |
|-----------|-------------|----------|
| TA7001    | A:T → G:C   | hisG1775 |
| TA7002    | T:A → A:T   | hisC9138 |
| 20 TA7003 | T:A → G:C   | hisG9074 |
| TA7004    | G:C → A:T   | hisG9133 |
| TA7005    | G:C → A:T   | hisG9130 |
| TA7006    | G:C → C:G   | hisC9070 |

These strains, which revert at similar spontaneous frequencies  
 25 [approximately 1 to 10 x 10<sup>9</sup>] can be exposed and plated separately for determining mutational spectra, or mixed and exposed together to assess broad mutagenic potential. The assay takes 3 days from start to finish and can be performed in 96 well- or 384 well-microtiter plates. Revertant colonies are scored using bromo-creosol purple indicator dye in the  
 30 growth medium. The mixed strains can be assayed first as part of a rapid

-137-

screening program. Since this six strain mixture is slightly less sensitive than individual strains tested alone, compounds which are negative for the mix can be retested using all six strains. For all but the weakest mutagens, the Ames II strain mixture appears to be capable of detecting reversion events even if only one strain is induced to revert. The mixed strains provide a means to perform rapid initial screening for genotoxins, while the battery of base-specific tester strains permit mutational spectra analysis.

As modified herein, the test compounds are linked to matrices with memories, that have been encoded with the identity of the test compounds. The assays can be performed on multiple test compounds simultaneously using arrays of matrices with memories or multiple matrices with memories encoded with the identity of the linked test compound and the array position or plate number into which the compound is introduced.

**f. Hybridization assays and reactions**

**(1) Hybridization reactions**

It is often desirable to detect or quantify very small concentrations of nucleic acids in biological samples. Typically, to perform such measurements, the nucleic acid in the sample [*i.e.*, the target nucleic acid] is hybridized to a detection oligonucleotide. In order to obtain a detectable signal proportional to the concentration of the target nucleic acid, either the target nucleic acid in the sample or the detection oligonucleotide is associated with a signal generating reporter element, such as a radioactive atom, a chromogenic or fluorogenic molecule, or an enzyme [such as alkaline phosphatase] that catalyzes a reaction that produces a detectable product. Numerous methods are available for detecting and quantifying the signal.

Following hybridization of a detection oligonucleotide with a target, the resulting signal-generating hybrid molecules must be separated from

-138-

unreacted target and detection oligonucleotides. In order to do so, many of the commonly used assays immobilize the target nucleic acids or detection oligonucleotides on solid supports. Presently available solid supports to which oligonucleotides are linked include nitrocellulose or  
5 nylon membranes, activated agarose supports, diazotized cellulose supports and non-porous polystyrene latex solid microspheres. Linkage to a solid support permits fractionation and subsequent identification of the hybridized nucleic acids, since the target nucleic acid may be directly captured by oligonucleotides immobilized on solid supports. More  
10 frequently, so-called "sandwich" hybridization systems are used. These systems employ a capture oligonucleotide covalently or otherwise attached to a solid support for capturing detection oligonucleotide-target nucleic acid adducts formed in solution [see, e.g., EP 276,302 and Gingeras et al. (1989) Proc. Natl. Acad. Sci. USA 86:1173]. Solid  
15 supports with linked oligonucleotides are also used in methods of affinity purification. Following hybridization or affinity purification, however, if identification of the linked molecule or biological material is required, the resulting complexes or hybrids or compounds must be subjected to analyses, such as sequencing. The combinations and methods herein  
20 eliminate the need for such analyses.

Use of matrices with memories in place of the solid support matrices used in the prior hybridization methods permits rapid identification of hybridizing molecules. The identity of the linked oligonucleotide is written or encoded into the memory. After reaction,  
25 hybrids are identified, such as by radioactivity or separation, and the identify of hybridizing molecules are determined by querying the memories.

## (2) Hybridization assays

Mixtures nucleic acid probes linked to the matrices with memories  
30 can be used for screening in assays that heretofore had to be done with

-139-

one probe at a time or with mixtures of probes followed by sequencing the hybridizing probes. There are numerous examples of such assays [see, e.g., U.S. Patent No. 5,292,874, "Nucleic acid probes to Staphylococcus aureus" to Milliman, and U.S. Patent No. 5,232,831, 5 "Nucleic acid probes to Streptococcus pyogenes" to Milliman, et al.; see, also, U.S. Patent Nos. 5,216,143, 5,284,747 5,352,579 and 5,374,718]. For example, U.S. Patent No. 5,232,831 provides probes for the detection of particular Streptococcus species from among related species and methods using the probes. These probes are based on 10 regions of Streptococcus rRNA that are not conserved among related Streptococcus species. Particular species are identified by hybridizing with mixtures of probes and ascertaining which probe(s) hybridize. By virtue of the instant matrices with memories, following hybridization, the identity of the hybridizing probes can be determined by querying the 15 memories, and thereby identifying the hybridizing probe.

i. **Combinatorial libraries and other libraries and screening methodologies**

The combinations of matrices with memories are applicable to virtually any synthetic scheme and library preparation and screening 20 protocol. These include, those discussed herein, and also methodologies and devices, such as the Chiron "pin" technology [see, e.g., International PCT application No. WO 94/11388; Geysen et al. (1985) Proc. Natl. Acad. Sci. U.S.A. 82:178; and Geysen et al. (1987) J. Immunol. Meth. 102:259-274] which relies on a support composed of annular synthesis 25 components that have an active surface for synthesis of a modular polymer and an inert support rod that is positioned axially to the annular synthesis components. This pin technology was developed for the simultaneous synthesis of multiple peptides. In particular the peptides are synthesized on polyacrylic acid grafted on the tip of polyethylene 30 pins, typically arranged in a microtiter format. Amino acid coupling is

-140-

effected by immersing the pins in a microtiter plate. The resulting peptides remain bound to the pins and can be reused.

As provided herein, "pins" may be linked to a memory or recording device, preferably encasing the device, or each pin may be coded and the code and the identity of the associated linked molecule(s) stored in a remote memory. As a result it will not be necessary to physically array the pins, rather the pins can be removed and mixed or sorted.

Also of interest herein, are DIVERSOMER™ technology libraries produced by simultaneous parallel synthesis schemes for production of nonoligomeric chemical diversity [see, e.g., U.S. Patent No. 5,424,483; Hobbs DeWitt et al. (1994) Drug Devel. Res. 33:116-124; Czarnik et al. (1994) Polym. Prepr. 35:985; Stankovic et al. (1994) in Innovation Perspect. Solid Phase Synth. Collect. Pap., Int. Symp., 3rd Epton, R. (Ed), pp. 391-6; DeWitt et al. (1994) Drug Dev. Res. 33:116-124; Hobbs DeWitt et al. (1993) Proc. Natl. Acad. Sci. U.S.A. 90:6909-6913]. In this technology a starting material is bonded to a solid phase, such as a matrix material, and is subsequently treated with reagents in a stepwise fashion. Because the products are linked to the solid support, multistep syntheses can be automated and multiple reactions can be performed simultaneously to produce libraries of small molecules. This technology can be readily improved by combining the matrices with memories or encoding the matrix supports in accord with the methods herein.

The matrices with memories, either those with memories in proximity or those in which the matrix includes a code stored in a remote memory, can be used in virtually any combinatorial library protocol. These protocols or methodologies and libraries, include but are not limited to those described in any of following references: Zuckermann et al. (1994) J. Med. Chem. 37:2678; Martin et al. (1995) J. Med. Chem. 38:1431; Campbell et al. (1995) J. Am. Chem. Soc. 117:5381; Salmon et al. (1993) Proc. Natl. Acad. Sci. U.S.A. 90:11708; Patek et al.

-141-

(1994) Tetrahedron Lett. 35:9169; Patek et al. (1995) Tetrahedron Lett. 36:2227; Hobbs DeWitt et al. (1993) Proc. Natl. Acad. Sci. U.S.A. 90:6906; Baldwin et al. (1995) J. Am. Chem. Soc. 117:5588; and any others.

5                                    h.        **Nucleic Acid Sequencing**

Methods of DNA sequencing based on hybridization of DNA fragments with a complete set of fixed length oligonucleotides [8-mers] that are immobilized individually as dots in a 2-dimensional matrix is sufficient for computer-assisted reconstruction of the sequences of

10 fragments up to 200 bases long [International PCT Application WO 92/10588]. The nucleic acid probes are of a length shorter than a target, which is hybridized to the probes under conditions such that only those probes having an exact complementary sequence are hybridized maximally, but those with mismatches in specific locations hybridize with

15 a reduced affinity, as can be determined by conditions necessary to dissociate the pairs of hybrids. Alignment of overlapping sequences from the hybridizing probes reconstructs the complement of the target [see, EP 0 535 242 A1, International PCT Application WO 95/00530, and Khrapko et al. (1989) FEBS Ltrs. 256:118-122]. The target

20 fragment with the sequence of interest is hybridized, generally under highly stringent conditions that tolerate no mismatches or as described below a selected number of mismatches, with mixtures of oligonucleotides [typically a mixture of octomers of all possible sequences] that are each immobilized on a matrix with memory that is encoded with the se-

25 quence of the probe. Upon hybridization, hybridizing probes are identified by routine methods, such as OD or using labeled probe, and the sequences of the hybridizing probes can be determined by retrieving the sequences from the linked memories. When hybridization is carried out under conditions in which no mismatches are tolerated, the sequence of

-142-

the target can then be determined by aligning overlapping sequences of the hybridizing probes.

Previous methods used to accomplish this process have incorporated microscopic arrays of nucleotide oligomers synthesized on small silicon based chips. It is difficult to synthesize such arrays and quality control the large number of spots on each chip (about 64,000 spots for 8-mer oligonucleotides, that number necessary to accomplish sequencing by hybridization). In the present method, each oligomer is independently synthesized on a batch of individual chips, those chips are tested for accuracy and purity of their respective oligomers, then one chip from each batch is added to a large pool containing oligomers having all possible sequences. After hybridization in batch mode with the gene segment to be sequenced, usually amplified by a method such as PCR, using appropriate primers, and labeled with a detectable [such as fluorescent] tag, the chips can be passed through a detector, such as described above for processing multiplexed assays, including multiplexed immunoassays, and the degree of binding to each oligomer can be determined. After exposing the batch to varying degrees of dissociating conditions, the devices can again be assayed for degree of binding, and the strength of binding to related sequences will relate the sequence of the gene segment [see, e.g., International PCT Application WO 95/00530].

**j. Separations, physical mapping and measurements of kinetics of binding and binding affinities**

Multiple blots [i.e., Western, Northern, Southern and/or dot blots] may be simultaneously reacted and processed. Each memory, in the form of a rectangle or other suitable, is linked or coated on one surface with material, such as nitrocellulose, to which or the analyte of interest binds or with which it reacts. The chips are arranged in an array, such as in



-143-

strips that can be formed into rectangles or suitable other shapes, circles, or in other geometries, and the respective x-y coordinate or other position-identifying coordinate(s), and, if needed, sheet number and/or other identifying information, is programmed into each memory.

- 5 Alternatively, they may be programmed with this identification, then positioned robotically or manually into an array configuration. They are preferably linked together, such as by reversible glue, or placing them in agarose, or by any suitable method as long as the reactive surface is not
- 10 from a Western Blot, nucleic acid from a Southern or Northern blot, dot blots, replica plated bacterial culture, or viral plaques, the memories are separated and mixed for reaction with a traditionally labeled, such as a fluorescent label, detection nucleic acid, protein, antibody or receptor of interest. Complexes are identified, and their origin in the blot determined
- 15 by retrieving the stored information in each chip. Quantitation may also be effected based on the amount of label bound.

A series of appropriately activated matrices with memories are arranged in an array, one or, preferably two dimensional. In one configuration, each chip is pre-programmed and placed in a specific

20 location that is entered into its memory, such as an x-y coordinate. At least one surface of the memory with matrix is treated so that the transferred reagent binds. For example, a piece of nitrocellulose can be fixed to one side of the memory device. The resulting array is then contacted with a separation medium whereby each reagent of interest is

25 transferred to and bound to the end of the matrix with memory such that the reagent location is known. The matrices are separated and pooled; multiple arrays may be pooled as long as source information is recorded in each memory. All matrices with memories are then contacted with detection agents that specifically bind to reagents in the mixture. The

30 matrices with memories are passed through a reading device, either after

-144-

an incubation for end point determinations or continuously for kinetic measurements. The reading device is a device that can detect label, such as fluorescence, and a reader, such as an RF reader, that can query the memory and identify each matrix. The rate of binding and maximum

5 binding and identify of bound reagents can be determined.

Dot blots, for example, can be used in hybridoma analysis to identify clones that secrete antibodies of desired reactivity and to determine the relative affinities of antibodies secreted by different cell lines. Matrices with memories that are activated to bind immunoglobulins

10 and with on-board information specifying their relative locations in the array are dipped in an array into the wells of microplates containing hybridoma cells. After incubation, they are withdrawn, rinsed, removed and exposed to labeled antigen. Matrices of desired specificity and affinity are selected and read thereby identifying the original wells

15 containing the hybridoma cells that produce the selected antibodies.

In other embodiments, the transfer medium [*i.e.*, the nitrocellulose or other such medium] may be part of the surface of the chip or array of chips that can bind to the separated species subsequent to separation. For example, the separation system, such as the agarose or polyacryl-

20 amide gel, can be included on the surface(s) of the matrix with memories in the array. After separation the surface will be activated with a photactivatable linker or suitable activating agent to thereby covalently link, such as by a photoflash, the separated molecules to the matrices in the array.

25 Alternatively, each matrix with memory may have one or more specific binding agents, such as an antibody or nucleic acid probe, attached (adsorbed, absorbed, or otherwise in physical contact) to matrix with memory. The matrix with memory and linked binding agent is then contacted with a medium containing the target(s). After contacting,

30 which permits binding of any targets to which the linked binding agents

-145-

specifically bind, the matrix with memory is processed to identify memories with matrices to which target has specifically bound via interaction with the binding agent. For example, the (1) the target is labeled, thereby permitted direct detection of complexes; (2) the memory  
5 with matrix is then contacted with a developing agent, such as a second antibody or detection probe, whereby binding agent-target complexes are detected; or (3) the detection agent is present during the reaction, such as non-specifically attached to the matrix with memory or by other method [thin film, coated on the matrix with memory, coated on  
10 nitrocellulose].

Such support bound analytes may also be used to analyze the kinetics of binding by continuously passing the supports through a label reading device during the reaction, and identify the labeled complexes. The binding agents can be eluted, either in a kinetically readable manner  
15 or in batch. In addition, since the recording devices may also include components that record reaction conditions, such as temperature and pH, kinetics, which are temperature and pH dependent, may be accurately calculated.

After elution, the support bound analytes may be identified to  
20 analyze kinetics of binding to the binding agent. Such binding and elution protocols may also be adapted to affinity purification methodologies.

#### k. Cell Sorting

The devices herein may also be used in methods of cell sorting. For example, the memory with matrix combinations are linked to selected  
25 antigens, information regarding the antigens is encoded into the memories, the resulting combinations are used in multi-analyte analyses of cells.

-146-

It is possible to identify a profile of cells exhibiting different surface markers [antigens, for example, or other ligands or receptor molecules] by using combinations of labeled and matrix memory-bound binding agents. In one embodiment, each agent, such as an antibody, capable of binding specifically to one of many different surface markers is bound to a different matrix with a memory. The nature of the recognized marker is recorded in the memory of each matrix-binding agent complex, and the mixture of binding-agent-matrix memory complexes is reacted with a mixture of cells. The cell-matrix complexes that result from binding agents attaching cells to the surfaces of the respective matrices are then reacted with a labeled [for example, fluorescent] reagent or mixture of reagents which also reacts with the cells. These labeled reagents can be the same or different from those coupled to the memory matrices. When the matrices are passed through a reader [to read the label and the memory], those that have bound cells can be identified and if necessary isolated. This application is particularly useful for screening for rare cells, for example stem cells in a bone marrow or peripheral lymphocyte sample, for detecting tumor cells in a bone marrow sample to be used for autologous transplantation, or for fetal cells in a maternal circulation.

In these embodiments, the memory with matrices herein can be counted and read with instruments, such as a device that operates on the principles of a Coulter counter, that are designed to count cells or particles. In using a Coulter Counter, a suspension of cells or particles is sucked through a minute hole in a glass tube. One electrode is placed within the tube and another is outside of the tube in the suspension. The passage of a particle through the hole temporarily interrupts the current; the number of interruptions is determined by a conventional scaling unit.

For use herein, such instruments are modified by including an RF reader [or other reader if another frequency or memory means is selected] so that the identity of the particle or cell [or antigen on the cell or other

-147-

encoded information] can be determined as the particle or cell passes through the hole and interrupts the current, and also, if needed, a means to detect label, such as fluorescent label. As the particle passes through the hole the RF reader will read the memory in the matrix that is linked to the particle. The particles also may be counted concurrently with the determination of the identity of the particle. Among the applications of this device and method, is a means to sort multiple types of cells at once.

**I. Drug delivery and detecting changes in internal conditions in the body**

Memories may also be combined with biocompatible supports and polymers that are used internally in the bodies of animals, such as drug delivery devices [see, e.g., U.S. Patent Nos. 5,447,533, 5,443,953, 5,383,873, 5,366,733, 5,324,324, 5,236,355, 5,114,719, 4,786,277, 4,779,806, 4,705,503, 4,702,732, 4,657,543, 4,542,025, 4,530,840, 4,450,150 and 4,351,337] or other biocompatible support [see, U.S. Patent No. 5,217,743 and U.S. Patent No. 4,973,493, which provide methods for enhancing the biocompatibility of matrix polymers]. Such biocompatible polymers include matrices of poly(ethylene-co-vinyl acetate) and matrices of a polyanhydride copolymer of a stearic acid dimer and sebacic acid [see, e.g., Sherwood et al. (1992) Bio/Technology 10:1446-1449].

The biocompatible drug delivery device in combination with the memory is introduced into the body. The device, generally by virtue of combination with a biosensor or other sensor, also monitors pH, temperature, electrolyte concentrations and other such physiological parameters and in response to preprogrammed changes, directs the drug delivery device to release or not release drugs or can be queried, whereby the change is detected and drug delivered or administered.

Alternatively, the device provided in combination with a biocompatible support and biosensor, such that the information

-148-

determined by the biosensor can be stored in the device memory. The combination of device and biosensor is introduced into the body and is used to monitor internal conditions, such as glucose level, which level is written to memory. The internal condition, such as glucose level,  
5 electrolytes, particularly potassium, pH, hormone levels, and other such level, can then be determined by querying the device.

In one embodiment, the device, preferably one containing a volatile memory that is read to and written using RF, linked to a biosensor [see, e.g., U.S. Patent No. 5,384,028 which provides a biosensor with a data  
10 memory that stores data] that can detect a change in an internal condition, such as glucose or electrolyte, and store or report that change via RF to the linked matrix with memory, which records such change as a data point in the memory, which can then be queried. The animal is then scanned with RF and the presence of the data point is indicative of a  
15 change. Thus, instead of sampling the body fluid, the memory with matrix with linked biosensor is introduced into a site in the body, and can be queried externally. For example, the sensor can be embedded under the skin and scanned periodically, or the scanner is worn on the body, such as on the wrist, and the matrix with memory either periodically,  
20 intermittently, or continuously sends signals; the scanner is linked to an infusion device and automatically, when triggered triggers infusion or alters infusion rate.

**m. Multiplexed or coupled protocols in which the synthesis steps [the chemistry] is coupled to subsequent uses of the synthesized molecules**  
25

Multiplexed or multiple step processes in which compounds are synthesized and then assayed without any intermediate identification steps are provided herein. Since the memories with matrices permit identification of linked or proximate or associated molecules or biological  
30 particles, there is no need to identify such molecules or biological

-149-

particles during any preparative and subsequent assaying steps or processing steps. Thus, the chemistry [synthesis] can be directly coupled to the biology [assaying, screening or any other application disclosed herein]. For purposes herein this coupling is referred to as multiplexing.

5 Thus, high speed synthesis can be coupled to high throughput screening protocols.

**F. Applications of the memories with matrices and luminescing matrices with memories in combinatorial syntheses and preparation of libraries**

10 Libraries of diverse molecules are critical for identification of new pharmaceuticals. A diversity library has three components: solid support matrix, linker and synthetic target. The support is a matrix material as described herein that is stable to a wide range of reaction conditoin and solvents; the linker is selectively cleavable and does not leave a  
15 functionalized appendage on the synthetic target; and the target is synthesized in high yield and purity. For use herein, the diversity library further includes a memory or recording device in combination with the support matrix. The memory is linked, encased, in proximity with or otherwise associate with each matrix particle, whereby the identify of  
20 synthesized targets is written into the memory.

The matrices with memories are linked to molecules and particles that are components of libraries to electronically tagged combinatorial libraries. Particularly preferred libraries are the combinatorial libraries that containing matrices with memories that employ radio frequencies for  
25 reading and writing.

**1. Oligomer and polypeptide libraries**

**a. Bio-oligomer libraries**

One exemplary method for generating a library [see, U.S. Patent No. 5,382,513] involves repeating the steps of (1) providing at least two  
30 aliquots of a solid phase support; separately introducing a set of subunits

-150-

to the aliquots of the solid phase support; completely coupling the subunit to substantially all sites of the solid phase support to form a solid phase support/new subunit combination, assessing the completeness of coupling and if necessary, forcing the reaction to completeness;

- 5 thoroughly mixing the aliquots of solid phase support/new subunit combination; and, after repeating the foregoing steps the desired number of times, removing protecting groups such that the bio-oligomer remains linked to the solid phase support. In one embodiment, the subunit may be an amino acid, and the bio-oligomer may be a peptide. In another
- 10 embodiment, the subunit may be a nucleoside and the bio-oligomer may be an oligonucleotide. In a further embodiment, the nucleoside is deoxyribonucleic acid; in yet another embodiment, the nucleoside is ribonucleic acid. In a further embodiment, the subunit may be an amino acid, oligosaccharide, oligoglycosides or a nucleoside, and the bio-oligomer
- 15 omer may be a peptide-oligonucleotide chimera or other chimera. Each solid phase support is attached to a single bio-oligomer species and all possible combinations of monomer [or multimers in certain embodiments] subunits of which the bio-oligomers are composed are included in the collection.
- 20 In practicing this method herein, the support matrix has a recording device with programmable memory, encased, linked or otherwise attached to the matrix material, and at each step in the synthesis the support matrix to which the nascent polymer is attached is programmed to record the identity of the subunit that is added. At the completion of
- 25 synthesis of each biopolymer, the resulting biopolymers linked to the supports are mixed.

- After mixing an acceptor molecule or substrate molecule of interest is added. The acceptor molecule is one that recognizes and binds to one or more solid phase matrices with memory/bio-oligomer species within
- 30 the mixture or the substrate molecule will undergo a chemical reaction



-151-

catalyzed by one or more solid phase matrix with memory/bio-oligomer species within the library. The resulting combinations that bind to the acceptor molecule or catalyze reaction are selected. The memory in the matrix-memory combination is read and the identity of the active bio-oligomer species is determined.

**b. Split Bead Sequential Syntheses**

Various schemes for split bead syntheses of polymers [FIGURE 1], peptides [FIGURE 2], nucleic acids [FIGURE 3] and organic molecules based on a pharmacophore monomer [FIGURE 4] are provided. Selected matrices with memory particles are placed in a suitable separation system, such as a funnel [see, FIGURE 5]. After each synthetic step, each particle is scanned [i.e., read] as it passes the RF transmitter, and information identifying the added component or class of components is stored in memory. For each type of synthesis a code can be programmed [i.e., a 1 at position 1,1 in the memory could, for example, represent alanine at the first position in the peptide]. A host computer or decoder/encoder is programmed to send the appropriate signal to a transmitter that results in the appropriate information stored in the memory [i.e. for alanine as amino acid 1, a 1 stored at position 1,1]. When read, the host computer or decoder/encoder can interpret the signal read from and transmitted from the memory.

In an exemplary embodiment, a selected number of beads [i.e., particulate matrices with memories [matrix particles linked to recording devices], typically at least  $10^3$ , more often  $10^4$ , and desirably at least  $10^5$  or more up to and perhaps exceeding  $10^{15}$ , are selected or prepared. The beads are then divided into groups, depending upon the number of choices for the first component of the molecule. They are divided into a number of containers equal to or less than [for pooled screening, nested libraries or the other such methods] the number of choices. The containers can be microtiter wells, Merrifield synthesis vessels, columns, test

-152-

tubes, gels, etc. The appropriate reagents and monomer are added to each container and the beads in the first container are scanned with electromagnetic with radiation, preferably high frequency radio waves, to transmit information and encode the memory to identify the first  
5 monomer. The beads in the second container are so treated. The beads are then combined and separated according to the combinatorial protocol, and at each stage of added monomer each separate group is labeled by inputting data specific to the monomer. At the end of the synthesis protocol each bead has an oligomer attached and information identifying  
10 the oligomer stored in memory in a form that can be retrieved and decoded to reveal the identity of each oligomer.

An 8-member decapeptide library was designed, synthesized, and screened against an antibody specifically generated against one of the library members using the matrices with memories. Rapid and clean  
15 encoding and decoding of structural information using radio frequency signals, coupling of combinatorial chemical synthesis to biological assay protocols, and potential to sense and measure biodata using suitable biosensors, such as a temperature thermistor or pH electrode, embedded within the devices have been demonstrated. The "split and pool" method  
20 [see, e.g., Furka *et al.* (1991) *Int. J. Pept. Protein Res.* 37:487-493; Lam *et al.* (1991) *Nature* 354:82-84; and Sebestyén *et al.* (1993) *Bioorg. Med. Chem. Lett.* 3:413-418] was used to generate the library. An ELISA [see e.g., Harlow *et al.* (1988) *Antibodies, a laboratory manual*, Cold Spring Harbor, NY] was used to screen the library for the peptide  
25 specific for the antibody.

## 2. "Nested" combinatorial library protocols

In this type of protocol libraries of sublibraries are screened, and a sublibrary selected for further screening [see, e.g., Zuckermann *et al.* (1994) *J. Med. Chem.* 37:2678-2685; and Zuckermann *et al.* (1992) *J.*  
30 *Am. Chem. Soc.* 114:10646-10647]. In this method, three sets of

-153-

monomers were chosen from commercially available monomers, a set of four aromatic hydrophobic monomers, a set of three hydroxylic monomers, a set of seventeen diverse monomers, and three N-termini were selected. The selection was based on an analysis of the target  
5 receptor and known ligands. A library containing eighteen mixtures, generated from the six permutations of the three monomer sets, times three N-termini was prepared. Each mixture of all combinations of the three sets of amines, four sets of hydrophobic monomers and seventeen  
10 diverse monomers was then assayed. The most potent mixture was selected for deconvolution by synthesis of pools of combinatorial mixtures of the components of the selected pool. This process was repeated, until individual compounds were selected.

Tagging the mixtures with the matrices with memories will greatly simplify the above protocol. Instead of screening each mixture  
15 separately, each matrix particle with memory will be prepared with sets of the compounds, analogous to the mixtures of compounds. The resulting matrix particles with memories and linked compounds can be combined and then assayed. As with any of the methods provided herein, the linked compounds [molecules or biological particles] can be  
20 cleaved from the matrix with memory prior to assaying or anytime thereafter, as long as the cleaved molecules remain in proximity to the device or in some manner can be identified as the molecules or particles that were linked to the device. The matrix particle(s) with memories that exhibit the highest affinity [bind the greatest amount of sample at  
25 equilibrium] are selected and identified by querying the memory to identify the group of compounds. This group of compounds is then deconvoluted and further screened by repeating this process, on or off the matrices with memories, until high affinity compounds are selected.

-154-

### 3. Other combinatorial protocols

The matrices with memories provided herein may be used as supports in any synthetic scheme and for any protocol, including protocols for synthesis of solid state materials. Combinatorial approaches have been developed for parallel synthesis of libraries of solid state materials [see, e.g., Xiang *et al.* (1995) *Science* **268**:1738-1740]. In particular, arrays containing different combinations, stoichiometries, and deposition sequences of inorganics, such as BaCO<sub>3</sub>, BiO<sub>3</sub>, CaO, CuO, PbO, SrCO<sub>3</sub> and Y<sub>2</sub>O<sub>3</sub>, for screening as superconductors have been prepared. These arrays may be combined with memories that identify position and the array and/or deposited material.

The following examples are included for illustrative purposes only and are not intended to limit the scope of the invention.

#### EXAMPLE 1

##### 15 Formulation of a polystyrene polymer on glass and derivatization of polystyrene

A glass surface of any conformation [beads for exemplification purposes (1)] that contain a selected memory device that coat the device or that can be used in proximity to the device or subsequently linked to the device is coated with a layer of polystyrene that is derivatized so that it contains a cleavable linker, such as an acid cleavable linker. To effect such coating a bead, for example, is coated with a layer of a solution of styrene, chloromethylated styrene, divinyl benzene, benzoyl peroxide [88/10/1/1/, molar ratio] and heated at 70° C for 24 h. The result is a cross-linked chloromethylated polystyrene on glass (2). Treatment of (2) with ammonia [2 M in 1,4-dioxane, overnight] produces aminomethylated coated beads (3). The amino group on (3) is coupled with polyethylene glycol dicarboxymethyl ether (4) [n ≈ 20] under standard conditions [PyBop/DIEA] to yield carboxylic acid derivatized beads (5). Coupling of (5) with modified PAL [PAL is pyridylalanine] linker (6) under the same

-155-

conditions produces a bead that is coated with polystyrene that has an acid cleavable linker (7).

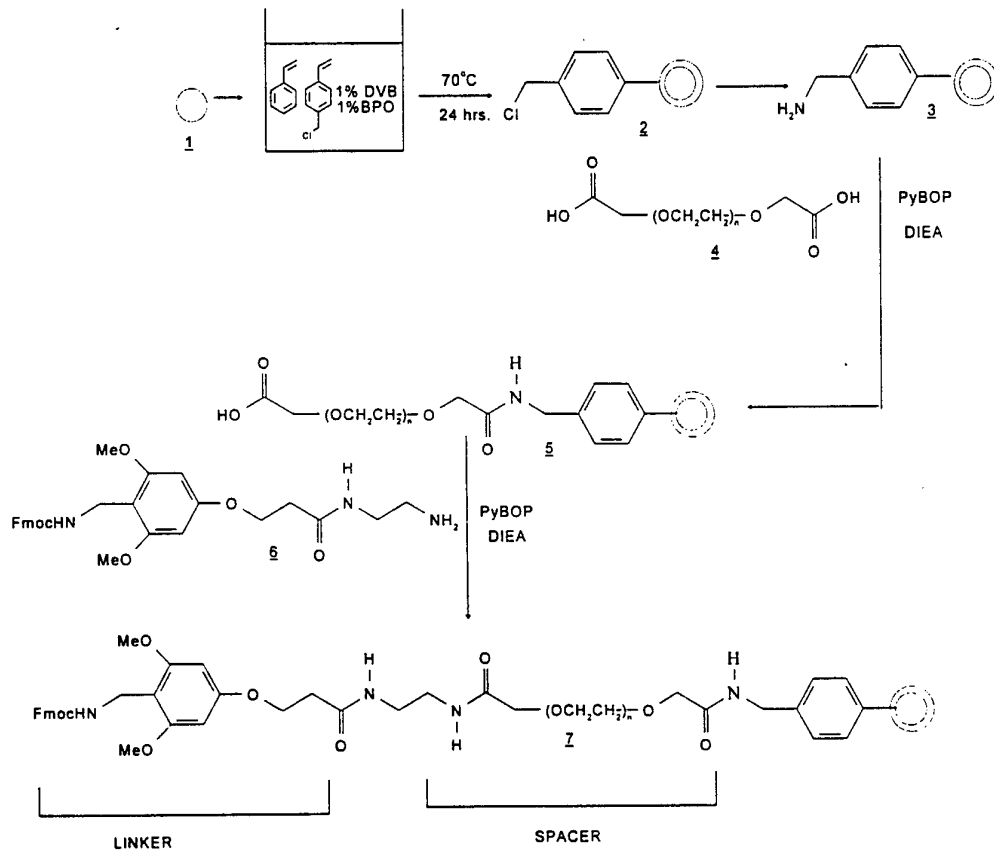

25 The resulting coated beads with memories are then used as solid support for molecular syntheses or for linkage of any desired substrate.

## EXAMPLE 2

### Construction of a matrix with memory

30 A matrix with memory was constructed from (a) and (b) as follows:

(a) A small (8 x 1 x 1 mm) semiconductor memory device [the IPTT-100 purchased from Bio Medic Data Systems, Inc., Maywood, NJ; see, also U.S. Patent Nos. 5,422,636, 5,420,579, 5,262,772, 5,252,962, 5,250,962, 5,074,318, and RE 34,936].

-156-

The memory device is a transponder [IPTT-100, Bio Medic Data Systems, Inc., Maywood, NJ] that includes a remotely addressable memory [EEPROM]. The transponder receives, stores and emits radio frequency signals of different frequencies so that it can be remotely  
5 programmed with information regarding synthetic steps and the constituents of linked or proximate molecules or biological particles.

These devices are designed to operate without a battery, relying on the energy generated by the radio frequency pulses used in the encoding process. Also, it is important to note that additional sensors such as  
10 temperature [as in this case], pH, or concentration measuring devices can be installed. The resulting combinations are capable of withstanding most reagents and conditions used in synthetic organic chemistry, including temperatures from -78 to 150° C.

The transponder was encoded and read with a device that emits  
15 and reads RF frequencies [Bio Medic Data Systems Inc. DAS-5001 CONSOLE™ System, see, also U.S. Patent No. 5,252,962].

These memory devices include EEPROM (Electrical, Erasable, Programmable, Read-Only Memory) "flash" unit and a temperature sensing device able to accept or emit information at any time. At each  
20 step of the combinatorial "split and pool" sequence, encoding information is sent from a distance in the form of radio frequency pulses at 145 kHz and stored until decoding is needed. When needed the radio frequency signals are retrieved using a specially assembled apparatus capable of reading the radio frequency code from a distance [DAS-5001 CONSOLE™  
25 from Bio Medic Data Systems, Inc., Maywood, NJ; see, e.g., U.S. Patent Nos. 5,422,636, 5,420,579, 5,262,772, 5,252,962 and 5,250,962, 5,252,962 and 5,262,772].

(b) TENTAGEL® polymer beads carrying an acid-cleavable linker [TENTAGEL S Am cat # S30 022, RAPP Polymer, Tübingen, Germany].

-157-

(c) A chemically inert surrounding porous support [polypropylene AA, SPECTRUM, Houston, TX].

One transponder and about 20 mg of the derivatized TENTAGEL™ beads have been sealed in a small [of a size just sufficient to hold the  
5 beads and transponder] porous polypropylene microvessel [see, Examples 3 and 4].

### EXAMPLE 3

#### MICROVESSELS

##### A. FIGURES 11-13

10 FIGURES 11-13 illustrate an embodiment of a microvessel 20 provided herein. The microvessel 20 is a generally elongated body with walls 22 of porous or semi-permeable non-reactive material which are sealed at both ends with one or more solid-material cap assemblies 42,  
15 44. The microvessel 20 retains particulate matrix materials 40 and one or more recording devices 34. In the preferred embodiment illustrated in FIGURES 11-13, the recording device includes a shell 36 that is impervious to the processing steps or solutions with which the microvessel may come into contact, but which permits transmission of  
20 electromagnetic signals, including radiofrequency, magnetic or optical signals, to and from the recording media of the recording device.

The preferred microvessel 20 is generally cylindrically shaped and has two solid-material cap assemblies 42, 44. The cap assemblies may be formed of any material that is non-reactive with the solutions with which the microvessel will come into contact. Such appropriate materials  
25 include, for example, plastic, teflon, poly-tetra-fluoro-ethylene (hereinafter, PTFE) or polypropylene. Each cap assembly 42, 44 preferably includes a support base 26, 28, respectively, and an end cap 24, 30, respectively. Each support base 26, 28 is permanently attached to the walls 22 of the vessel by known means such as bonding with  
30 appropriate adhesives or heat treatment, either by heat-shrinking the wall

-158-

material onto the lower portions of the support bases 26,28, or by fusing the wall material with the support base material.

Preferably, at least one of the caps 24,30 is removably attached to its cap base 26, for example by providing complementary threads on the

5 support base and the end cap so that the end cap can be screwed into the support base, as illustrated in Figure 12. Other possible means for attaching the end cap to the support base will be apparent to those in the art, and can include snap rings, spring tabs, and bayonet connectors, among others. The end cap 24, has one or more slots, bores, or recesses

10 32 formed in its outer surface to facilitate removal or replacement, with the user's fingers and/or by use of an appropriate tool. For the example illustrated, a spanner wrench having pegs spaced at the same separation as the recesses 32 can be used by inserting the pegs into the recesses. For a single slot, removal and replacement of the end cap could be

15 achieved by using a screwdriver. Protruding tabs, rims, knurled edges or other means to enhance the ability to grasp the end cap can be used for manual assembly/disassembly of the microvessel. The cap assembly 42 at the opposite end of the microvessel can be permanently sealed using an adhesive or heat treatment to attach the support base 28 to the end

20 cap 30, or the cap assembly 42 can be molded as a single piece, combining the support base 28 and the end cap 30.

Retained within the microvessel 20 are particle matrix materials 40 and a memory device 34. The recording device 34, in the preferred embodiment illustrated, includes a data storage unit(s) 38 and a shell 36

25 that protects the recording device 38 from the processing steps and/or solutions to which the microvessel are subjected. This shell 36 is preferably constructed of material that is non-reactive with and impervious to the solutions with which the microvessel may come into contact, and which is penetrable by the electromagnetic radiation, or

30 similar means, used to read from and write to the memory device. The



-159-

preferred device is presently a modified form of the IPTT-100 [Bio Medic Data Systems, Inc. ("BMDS"), Maywood, NJ; see, also U.S. Patent Nos. 5,422,636, 5,420,579, 5,262,772, 5,252,962 and 5,250,962 ], which generally contains an electrically programmable memory chip 130 and  
5 decoding and power conversion circuitry 132 mounted on an elongated ceramic circuit board 134 and connected to an LC oscillator, comprising capacitor 138 and coil 136 wound around a ferrite core, which inductively receives and responds to a frequency-modulated magnetic signal generated by a similar LC oscillator in the write device, allowing the  
10 device to be remotely encoded and remotely read at a distance on the order of 1 cm or less. The device has been modified from the supplier's standard commercially-available form to provide physical dimensions to facilitate placement in the microvessel 20. The modification involves application of the simple and well-known relationship between inductor  
15 core area and length, the permeability of the core material, and the number of windings, i.e.,  $L$  (inductance) =  $N^2\mu A / \underline{l}$ , where  $N$  is the number of windings,  $\mu$  the permeability of the core,  $A$  is the core area and  $\underline{l}$  is the core length.

Other remotely programmable and readable tags are commercially  
20 available which may be used in the inventive system, such as those manufactured by Identification Device Technology, UK. These devices have circuitry and operational parameters similar to the device described above, but it may be necessary to modify the coil to reduce the access range to less than or equal to 1 cm. It is generally preferred that the  
25 responder, i.e., the memory device, and the transceiver in the control system be from the same manufacturer to assure complete compatibility.

The illustrated microvessel, as illustrated in FIGS. 11-13, is of a size sufficient to contain at least one recording device and one matrix particle, such as a TENTAGEL™ bead. The device is typically 20 mm in

-160-

length [i.e., the largest dimension] or smaller, with a diameter of approximately 5 mm or less, although other sizes are also contemplated. These sizes are sufficient to contain from about 1 mg up to about 1 g of matrix particle, and thus range from about 1 mm up to 100 mm in the largest dimension, typically about 5 mm to about 50 mm, preferably 10 mm to 30 mm, and most preferably about 15 to 25 mm. The size, of course can be smaller than those specified or larger. The wall material of the microvessel is PTFE mesh having a preferably about 50  $\mu\text{M}$  to 100  $\mu\text{M}$ , generally 50 to 70  $\mu\text{M}$  hole size that is commercially available. The size of course is selected to be sufficiently small to retain the matrix particles. The cap apparatus is machined rod PTFE [commercially available from McMaster Carr, as Part #8546K11].

The matrix material is selected based upon the particular use of the microvessel; for example, a functionalized resin, such as TENTAGEL™ resin, commercially available from Rapp Polymere, Tubingen, Germany, is preferred for use in peptide synthesis and similar processes. The matrix material may also include fluophores or scintillants as described herein.

Alternative embodiments of the microvessel will be appreciated and include, for example, a pouch, including porous or semi-permeable material, which is permanently sealed to itself and contains matrix material and one or more memories.

#### B. FIGURES 14-16

FIGURES 14-16 illustrate an alternate embodiment of a microvessel provided herein. Like the microvessel described in Example 3, this embodiment of the microvessel also retains particulate matrix materials and one or more recording devices (not illustrated). The microvessel has a single-piece solid material frame 82, including a top ring 84, two support ribs 88, 100 disposed diametrically opposite each other and a bottom cap 86. The solid material frame 82 may be constructed of any material which is non-reactive with the solutions with which the

-161-

microvessel will come into contact. Such appropriate materials include, for example, plastic, teflon, poly-tetra-fluoro-ethylene (hereinafter, PTFE) or polypropylene, and formation may be by molding or machining of the selected material, with the former being preferred for economy of  
5 manufacture.

The sidewall of the microvessel 98 is formed of porous or semi-permeable non-reactive material, such as PTFE mesh, preferably having a 70 $\mu$ M pore size. The sidewall is preferably attached to the top ring 84 and bottom cap 86 of the solid material frame 82. Such attachment may  
10 be by known means such as bonding with appropriate glues or other chemicals or heat, with heat being preferred.

In the embodiment of FIGURES 14-16, the two support ribs 88, 100 are positioned opposite one another, however, any number of support ribs, i.e., one or more, may be provided. The microvessel  
15 sidewall 98 need not be fully attached to the support ribs 88, 100, however, the molding process by which the microvessels are formed may result in attachment at all contact points between the frame and the sidewall.

In the preferred manufacturing process, the sidewall material, a flat  
20 sheet of mesh, is rolled into a cylinder and placed inside the mold. The frame material is injected into the mold around the mesh, causing the frame to fuse to the mesh at all contact points, and sealing the edges of the mesh to close the cylinder.

In the embodiment illustrated in FIGS. 14-15, the microvessel is  
25 configured with a removable end cap 90. The end cap 90 is preferably constructed of the same material as the solid material frame 82. A snap ring, or, as illustrated, projections 92, 94 extend downward from the inside surface of the end cap 90. The projections 92, 94 have a flange which mates with a groove 96 formed in the inner wall of top ring 84  
30 when pressed into the top ring to releasably secure the end cap 90 to the

-162-

microvessel 80. As will be apparent, other means for releasably securing the end cap 90 to the top ring 84 can be used, including, but not limited to, those alternatives stated for the embodiment of FIGURES 11-13.

The dimensions vary as described for the microvessel of FIGURES 11-13  
5 and elsewhere herein.

In other embodiments, these vessels fabricated in any desired or convenient geometry, such as conical shapes. They can be solid at one end, and only require a single cap or sealable end.

These microvessels are preferably fabricated as follows. The solid  
10 portions, such as the solid cap and body, are fabricated from a polypropylene resin, Moplen resin [e.g., V29G PP resin from Montell, Newark DE, a distributor for Himont, Italy]. The mesh portion is fabricated from a polypropylene, polyester, polyethylene or fluorophore-containing mesh [e.g., PROPYLTEX®, FLUORTEX®, and other such  
15 meshes, including cat. no. 9-70/22 available from TETKO® Inc, Briarcliff Manor, NY, which prepares woven screening media, polypropylene mesh, ETF mesh, PTFE mesh, polymers from W.L. Gore. The pores are any suitable size [typically about 50-100  $\mu$ M, depending upon the size of the particulate matrix material] that permits contact with the synthetic  
20 components in the medium, but retains the particulate matrix particles.

#### EXAMPLE 4

##### Manual system

Illustrated in FIGURE 17 is a program/read station for writing to and reading from the memory devices in the microvessel. The electronic  
25 components are commercially available from the same supplier of the memory devices, e.g., BMDS or ID TAG [Bracknell Berks RG12 3XQ, UK], so that the basic operations and frequency are compatible. The basic controller 170 and the transceiver 172 are disposed within a housing 174 which has a recessed area 176 positioned within the transmission range  
30 of coil 178. The microvessel 180 may be placed anywhere within

-163-

recessed area 176, in any orientation, for both programming and reading functions. Basic controller 170 is connected to the system controller 182, illustrated here as a functional block, which provides the commands and encoded data for writing to the memory device in the microvessel  
5 and which receives and decodes data from the memory device during the read function. System controller 182 is typically a PC or lap top computer which has been programmed with control software 184 for the various write and read functions.

An example of the operation of the system of FIGURE 17 is  
10 illustrated in FIGURE 18. When power is supplied to the system, transceiver 172 emits an interrogation signal 185 to test for the presence of a memory device, i.e., a responder, within its detection range. The interrogation signal 185 is essentially a read signal that is continuously transmitted until a response 186 is received. The user manually places a  
15 microvessel 180 within the recessed area 176 so that the interrogation signal 185 provides a response to the controllers indicating the presence on the microvessel. The system receives the interrogation signal and performs a decode operation 187 to determine the data on the memory device within the microvessel, which data may include identification of  
20 the device and data concerning prior operations to which the microvessel has been exposed. Based upon the data obtained, the system makes a determination 188 of whether additional information is to be written. The system then performs a write operation 189 to record the immediately preceding operation. The write operation 189 involves modulating the  
25 transmitted signal as a series of "0's" and "1's", which are recorded on the memory chip, which typically has a 128 bit capacity. After completion of the programming step 189, an error check 190 is performed wherein a second read signal is emitted to verify the data that was written for integrity and correct content. If the correct data is not  
30 verified, the system may attempt to perform the write operation 189

-164-

again. After verification of the correct data, if the microvessel is one that should proceed to another operation, the system controller 182 will display instructions 192 for direction of the microvessel to the next process step.

- 5           The read operation is the same as the beginning of the write operation, with the interrogation signal being continuously transmitted, or transmitted at regular intervals, until a response is received. The response signal from the memory device in the microvessel 180 is conducted to system controller 182 for decoding and output of the data
- 10 that is stored on the memory device. Software within the system controller 182 includes a data base mapping function which provides an index for identifying the process step associated with data written at one or more locations in the memory device. The system memory within the system controller 182 will retain the identification and process steps
- 15 for each microvessel, and an output display of the information relating to each microvessel can indicate both where the microvessel has been, and where it should go in subsequent steps, if any. After the data stored within the microvessel has been read, it is removed from the interrogation field and advanced to its next process step.

20

#### EXAMPLE 5

##### Preparation of a library and encoding the matrices with memories

- A pool of the matrices with memories prepared as in EXAMPLE 2 was split into two equal groups. Each group was then addressed and write-encoded with a unique radio frequency signal corresponding to the
- 25 building block, in this instance an amino acid, to be added to that group.

- The matrices with memories were then pooled, and common reactions and manipulations such as washing and drying, were performed. The pool was then re-split and each group was encoded with a second set of radio frequency signals corresponding to the next set of
- 30 building blocks to be introduced, and the reactions were performed

-165-

accordingly. This process was repeated until the synthesis was completed. The semiconductor devices also recorded temperature and can be modified to record other reaction conditions and parameters for each synthetic step for storage and future retrieval.

- 5 Ninety-six matrices with memories were used to construct a 24-member peptide library using a 3 x 2 x 2 x 2 "split and pool" strategy. The reactions, standard Fmoc peptide syntheses [see, e.g., Barany et al. (1987) Int. J. Peptide Protein Res. 30:705-739] were carried out separately with each group. All reactions were performed at ambient
- 10 temperature; fmoc deprotection steps were run for 0.5 h; coupling steps were run for 1 h; and cleavage for 2 h. This number was selected to ensure the statistical formation of a 24-member library [see, Burgess et al. (1994) J. Med. Chem. 37:2985].

- Each matrix with memory in the 96-member pool was decoded
- 15 using a specifically designed radio frequency memory retrieving device [Bio Medic Data Systems Inc. DAS-5001 CONSOLE™ System, see, also U.S. Patent No. 5,252,962 and U.S. Patent No. 5,262,772] the identity of the peptide on each matrix with memory [Table 2]. The structural identity of each peptide was confirmed by mass spectrometry and <sup>1</sup>H
- 20 NMR spectroscopy. The content of peptide in each crude sample was determined by HPLC to be higher than 90% prior to any purification and could be increased further by standard chromatographic techniques.

| TABLE 2   |         |                 |  |                            |
|---|---------|-----------------|--|----------------------------|
| Radio frequency Encoded Combinatorial 24-member peptide library |         |                 |  |                            |
| Entry (SEQ ID)  | RF code | Peptide         | # of matrices with memories <sup>a,b</sup> | Mass (Actual) <sup>c</sup> |
| 1   | LAGD    | Leu-Ala-Gly-Asp | 3  | 372 (372.2)                |
| 2   | LEGD    | Leu-Glu-Gly-Asp | 4  | 432 (432.2)                |
| 3   | SAGD    | Ser-Ala-Gly-Asp | 5  | 348 (348.1)                |
| 30  | SEGD    | Ser-Glu-Gly-Asp | 5  | 406 (406.1)                |

| TABLE 2   |         |                 |  |                            |             |
|---|---------|-----------------|--|----------------------------|-------------|
| Radio frequency Encoded Combinatorial 24-member peptide library |         |                 |  |                            |             |
| Entry (SEQ ID)  | RF code | Peptide         | # of matrices with memories <sup>a,b</sup> | Mass (Actual) <sup>c</sup> |             |
| 5   | LAVD    | Leu-Ala-Val-Asp | 4  | 416 (416.2)                |             |
| 6   | LEVD    | Leu-Glu-Val-Asp | 6  | 474 (474.2)                |             |
| 7   | SAVD    | Ser-Ala-Val-Asp | 2  | 390 (390.2)                |             |
| 8   | SEVD    | Ser-Glu-Val-Asp | 3  | 446 (446.2)                |             |
| 5   | 9       | LAGF            | Leu-Ala-Gly-Phe                            | 5                          | 406 (406.2) |
| 10  | 10      | LEGF            | Leu-Glu-Gly-Phe                            | 5                          | 464 (464.2) |
|   | 11      | SAGF            | Ser-Ala-Gly-Phe                            | 5                          | 380 (380.2) |
|   | 12      | SEGF            | Ser-Glu-Gly-Phe                            | 6                          | 438 (438.2) |
|   | 13      | LAVF            | Leu-Ala-Val-Phe                            | 6                          | 448 (448.3) |
| 10  | 14      | LEVF            | Leu-Glu-Val-Phe                            | 2                          | xxx         |
|   | 15      | SAVF            | Ser-Ala-Val-Phe                            | 2                          | xxx         |
|   | 16      | SEVF            | Ser-Glu-Val-Phe                            | 1                          | 480 (480.2) |
|   | 17      | LAGK            | Leu-Ala-Gly-Lys                            | 2                          | 387 (387.3) |
|   | 18      | LEK             | Leu-Glu-Gly-Lys                            | 1                          | 445 (445.3) |
| 15  | 19      | SAGK            | Ser-Ala-Gly-Lys                            | 4                          | 361 (361.2) |
|   | 20      | SEK             | Ser-Glu-Gly-Lys                            | 3                          | 419 (419.2) |
|   | 21      | LAVK            | Leu-Ala-Val-Lys                            | 4                          | 429 (429.3) |
|   | 22      | LEVK            | Leu-Glu-Val-Lys                            | 6                          | 487 (487.3) |
|   | 23      | SAVK            | Ser-Ala-Val-Lys                            | 6                          | 403 (403.3) |
| 20  | 24      | SEVK            | Ser-Glu-Val-Lys                            | 6                          | 461 (461.3) |

<sup>a</sup> This is the number of packets of each matrix with memory containing the same peptide. <sup>b</sup> The ambient temperature was recorded by the sensor device of the chip in the matrices with memories at various points during the synthetic pathway. <sup>c</sup> Mass refers to (M + H) except entry 1 and 8 which refer to (M-H). Since each peptide has a unique mass, the mass spectrum confirms its structure. <sup>d</sup> HPLC conditions: Shimadzu SCL 10A with a MICROSORB-MV<sup>TM</sup> C-18 column (5  $\mu$ M, 100 Å; isocratic elution with acetonitrile/water.



-167-

**EXAMPLE 6****Synthesis of a decapeptide library****Materials and methods**

- (1) A memory device [IPTT-100, Bio Medic Data Systems, Inc., Maywood, NJ], which is 8 x 1 x 1 mm, and TENTAGEL® beads (20 mg) were encapsulated using a porous membrane wall and sealed (final size  $\approx$  10 x 2 x 2 mm) as described in Example 2. In particular, each memory with matrix microvessel 20 mg of TENTAGEL® resin carrying the acid-cleavable linker PAL.
- (2) Solvents and reagents [DMF, DCM, MeOH, Fmoc-amino acids, PyBOP, HATU, DIEA, and other reagents] were used as received. Mass spectra were recorded on an API I Perkin Elmer SCIEX Mass Spectrometer employing electrospray sample introduction. HPLC was performed with a Shimadzu SCI 10A with an AXXiOM C-18 column [5  $\mu$ m, 100Å; gradient: 0-20 min, 25-100% acetonitrile/water (0.1% TFA)]. UV spectra were recorded on a Shimadzu UV-1601 instrument. Peptide sequencing was performed using a Beckman model 6300 amino acid analyzer. Chemicals, solvents and reagents were obtained from the following companies: amino acid derivatives (CalBiochem); solvents (VWR; reagents (Aldrich-Sigma).
- (3) General procedure for Fmoc-amino acid coupling
- The matrix with memory microvessels were placed in a flat-bottomed flask. Enough DMF [ $v$ , ml, 0.75 ml per microvessel] was added to completely cover all the matrix with memory microvessels. Fmoc-amino acid, EDIA, and PyBOP [or HATU for the hindered amino acids Pro and Ile] were added sequentially with final concentrations of 0.1, 0.2, and 0.1 M, respectively. The flask was sealed and shaken gently at ambient temperature for 1 h. The solution was removed and the matrix with memory microvessels were washed with DMF (4 x  $v$ ), and re-subjected to the same coupling conditions with half the amount of

-168-

reagents. They are finally washed with DMF [4 x  $v_r$ ], MeOH [4 x  $v_4$ ], DCM [4 x  $v_4$ ], and dried under vacuum at ambient temperature.

#### (4) Fmoc-deprotection

The matrix with memory microvessels were placed in a flat  
5 bottomed flask. Enough 20% piperidine solution in DMF [ $v_r$  ml, 0.75 ml/matrix with memory microvessel] was added to completely cover the microvessels. The flask was sealed and gently shaken at ambient temperature for 30 min. Aliquots were removed and the UV absorption of the solution was measured at 302 nm to determine the Fmoc number.  
10 The matrix with memory microvessels were then washed with DMF [6 x  $v_r$ ] and DCM [6 x  $v_r$ ] and dried under vacuum at ambient temperature.

#### (5) Procedure for peptide cleavage from solid support

The TENTAGEL® beads [20-120 mg] from each matrix with memory microvessel were treated with 1 ml of TFA cleavage mixture  
15 [EDT:thioanisole;H<sub>2</sub>O:PhOH:TFA, 1.5:3:3:4.5:88, w/w] at ambient temperature for 1.5 hours. The resin beads were removed by filtration through a glass-wool plug, the solution was concentrated, diluted with water [2 ml], extracted with diethyl ether [8 x 2 ml], and lyophilized to yield the peptide as a white powder [4-20 mg].

#### 20 (6) Preparation of polyclonal antibodies

The peptide (SEQUENCE ID No. 25) with a cysteine at the N-terminus, was synthesized by standard solid phase methods using an automated Applied Biosystems 430A peptide synthesizer [see, Sakakibara (1971) Chemistry and Biochemistry of Amino Acids, Peptides and  
25 Proteins, Weinstein, ed, Vol. 1, Marcel Dekker, NY, pp. 51-85]. The synthetic peptide was conjugated to keyhole limpet hemocyanin using maleimidohexanoyl-N-hydroxysuccinimide as a cross-linking agent [see, Ishikawa et al. (1983) J. Immunoassay 4:209-237]. Rabbits were injected at multiple dorsal intradermal sites with 500  $\mu$ g peptide  
30 emulsified with complete Freund's adjuvant. The animals were boosted

-169-

regularly at 3-6 week intervals with 200  $\mu\text{g}$  of peptide conjugate emulsified in incomplete Freund's adjuvant. The titer of the antisera after a few booster injections was approximately 1:50,000 to 1:100,000 as determined by ELISA using the unconjugated peptide as the antigen.

**5** (7) Enzyme Linked Immunosorbant Assay [ELISA]

Plates were coated with 100  $\mu\text{l}$ /well of a 0.5  $\mu\text{g}/\mu\text{l}$  solution of peptides diluted in phosphate buffered saline [PBS] by incubating them overnight at 4° C. The plates were washed extensively with PBS and incubated with 200  $\mu\text{l}$  of 0.1% bovine serum albumin [BSA] in PBS for

**10** 1 h at room temperature. The plates were then washed with PBS and 100  $\mu\text{l}$  of prebled or rabbit anti-peptide [peptide of SEQ ID No. 25] antibody [1:100,000] was added to the duplicate wells. After a 1 h incubation at ambient temperature, the plates were washed with PBS and

**15** 100  $\mu\text{l}$  of peroxidase-goat-antirabbit IgG diluted in PBS supplemented with 0.1% BSA was added. After incubation for another hour at ambient temperature, the plates were extensively washed with PBS and 100  $\mu\text{l}$  of peroxidase substrate solution was added to each well. The plates were then incubated for 15 minutes at ambient temperature. The peroxidase reaction was measured by the increase in absorbance at 405 nm.

**20** The library

The library included the peptide having the sequence Met-Leu-Asp-Ser-Ile-Trp-Lys-Pro-Asp-Leu [MLDSIWKPDL; SEQ ID NO. 25], against which an antibody had been generated in rabbits [the peptide used for rabbits had an additional N-terminal Cys residue for linking], and seven

**25** other peptides differing at residues L, P, and/or I [SEQ ID NOs. 26-32 and the Scheme set forth in FIGURE 10].

The matrix with memory microvessels loaded with TENTAGEL<sup>®</sup> beads carrying PAL linkers [20 mg each] were split into two equal groups. Each group was encoded with the radio frequency code L or A [the one-

**30** letter symbols for amino acids leucine and alanine, respectively] and the

-170-

first coupling was carried out separately using Fmoc-Leu-OH or Fmoc-Ala-OH, respectively and ByBOP, or HATU for the sterically hindered amino acids [STEP 1, FIGURE 10]. The microvessels were then pooled, deprotected with 20% piperidine in DMF [Fmoc removal], encoded with the code D and subjected to coupling with Fmoc-Asp(OtBu)-OH and deprotection as above [STEP 2]. The microvessels were then re-split into two equal and fully randomized groups and encoding was performed on each group with the codes P or F and amino acid derivatives Fmoc-Pro-OH or Fmoc-Phe-OH were coupled, respectively [STEP 3]. The microvessels were pooled again and amino acid derivatives Fmoc-Lys(Boc)-OH and Fmoc-Trp(Boc)-OH were coupled sequentially with appropriate encoding and deprotection procedures [STEPS 4 and 5], and then were re-split into two equal groups, encoded appropriately and the amino acid derivatives Fmoc-Ile-OH or Fmoc-Gly-OH were coupled separately [STEP 6]. The matrix with memory microvessels were pooled, the amino groups deprotected and the remaining amino acids [Ser, Asp, Leu and Met] were sequentially introduced with appropriate encoding and deprotections using suitably protected Fmoc derivatives [STEPS 7-10]. The introduction of each amino acid was performed by double couplings at every step. The coupling efficiency for each step was generally over 90% as measured by Fmoc number determination after Fmoc deprotection [UV spectroscopy].

Decoding each matrix with memory allowed identification of identical units. It was observed that a fairly even distribution of matrix with memories over the entire library space was obtained. It should be noted that sorting out the matrices with memories at each split by decoding allows this random process to become an exact, "one compound-one matrix with memory method.

-171-

TENTAGEL® beads from matrices with memories with identical codes were pooled together and the peptides were cleaved from the resin separately with EDT:thioanisole:H<sub>2</sub>O:PhOH:TFA [1.5:3:3:4.5:88m, w/w]. The work-up and isolation procedures involved filtration, evaporation, 5 dilution with water, thorough extraction with diethyl ether, and lyophilization. The fully deprotected peptides were obtained as white solids, their structures were confirmed by mass spectroscopy, and their purity was determined by HPLC analysis. The peptide sequence in entry 2, [SEQ ID NO. 26] was confirmed by peptide amino acid sequence 10 analysis. Ambient reactor temperature was also measured at specific synthesis steps by the on-board temperature thermistor.

#### Biological screening of the peptide library

A rabbit polyclonal antibody generated specifically against the peptide SEQ ID NO. 25 was used to detect this specific sequence in the 15 REC™ peptide library by the ELISA method. The ELISA assay correctly identified the library member with the SEQ ID NO. 25 [100% binding]. The sequence of this peptide was also confirmed by the radio frequency code, mass spectroscopy, and amino acid sequence analysis.

It was also of interest to observe trends in the binding of the 20 antibody to the other members of the library. It was observed that the binding of each peptide was dependent on the type, position, and number of modifications from the parent sequence. Thus, replacement of I with G did not change significantly the antigenicity of the peptide. Substitution of L with A reduced antibody binding by ≈ 40% and 25 replacement of P with F essentially converted a peptide to a non-recognizable sequence. Replacement of two amino acids resulted in significant loss of binding. Thus the concurrent substitutions [I→G and P→F], [I→G and L→A], and [P→F and L→A] reduced antibody binding by ≈ 40, 60, and 92%, respectively. Finally, the peptide library member in 30 which I, P and L were replaced with G, F and A, respectively, was not

recognized by the antibody. Collectively, these results suggest that amino acids at the C-terminus of the peptide, especially P play an important role in this particular antibody-peptide recognition.

**EXAMPLE 7**

**5 Procedures for coating glass-enclosed memory devices with silylated polystyrene**

A procedure for coating glass-enclosed memory devices, such as the IPTT-100, is represented schematically as follows:

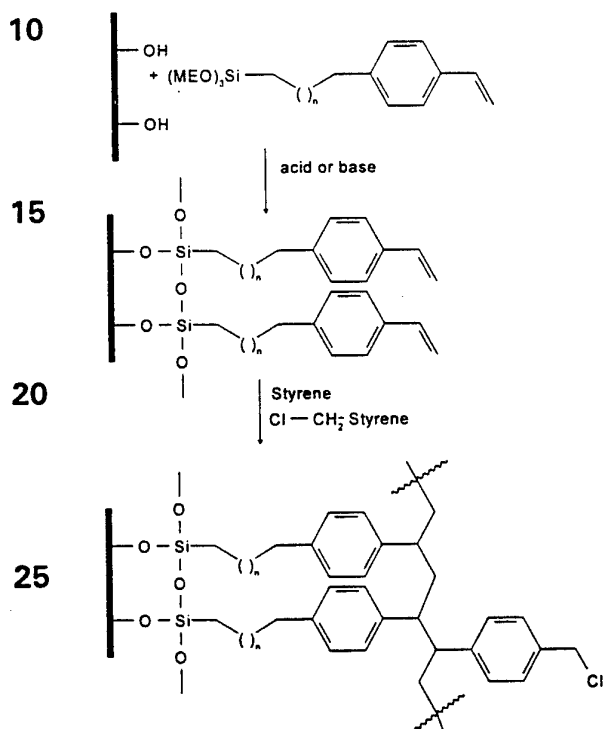

**A. Procedure A**

1. Before coating, the glass surface of the IPTT-100 transponder was cleaned using base, chloroform, ethanol and water, sequentially, and, then heated to 200° C [or 300° C] to remove water.

35 2. The residue from the solvents in step 1 were removed under vacuum.

-173-

3. N-styrylethyltrimethoxy silane HCl, chloromethyl styrene, divinyl benzene and benzoyl peroxide [9:1:0.1:0.2 mol] is stirred for 10 minutes.

4. The resulting mixture was coated on the cleaned glass,  
5 which was then baked at 150-200° C for 5 to 10 minutes in air or under nitrogen.

5. The coated glass was then sequentially washed with DCM, DMF and water. The resulting coating was stable in DCM, DMF, acid and base for at two weeks at 70° C.

10 **B. Procedure B**

1. Before coating, the glass surface is cleaned using base, chloroform, ethanol and water, sequentially, and, then heating to 200° C [or 300° C] to remove water.

2. The residue from the solvents in step 1 are removed under  
15 vacuum.

3. N-styrylethyltrimethoxy silane HCl [10-15%] is refluxed in toluene with the cleaned glass surface.

4. After reaction, the glass surface is washed with toluene, DCM, ethanol and water sequentially .

20 5. A mixture of chloromethyl styrene, divinyl benzene and benzoyl peroxide [molar ratio of N-styrylethyltrimethoxy silane HCl to the other compounds is 9:1:0.1:0.2 mol] is coated on the glass, which is then baked at 150-200° C for 10 to 60 minutes.

6. The coated glass is then sequentially washed with toluene,  
25 DCM, DMF and water.

-174-

**EXAMPLE 8****Preparation of scintillant-encased glass beads and chips****Materials:**

POPOP [Aldrich] or PPO [concentrations about 5 to 6 g/l], and/or  
5 *p*-bis-*o*-methylstyrylbenzene [bis-MSB] or di-phenylanthracene [DPA]  
[concentrations about 1 g/l], or scintillation wax [FlexiScint from  
Packard]. Precise concentrations may be determined empirically  
depending upon the selected mixture of components.

Porous glass beads [Sigma]

10 IPTT-100 transponders [see, Examples 2-4].

**A. Preparation of scintillant coated beads**

Porous glass beads are soaked in a mixture of PPO [22-25% by  
weight] and bis-MSB [up to 1% by weight] in a monomer solution, such  
styrene or vinyltoluene, or in hot liquified scintillation wax [3-5  
15 volume/volume of bead]. A layer of polystyrene [about 2 to 4  $\mu$ M] is then  
applied. A peptide is either synthesized on the polystyrene, as described  
above, or is coated [adsorbed] or linked via a cleavable linker to the  
polystyrene.

**B. Preparation of scintillant coated matrix with memory beads**

20 1. The porous glass beads are replaced with glass  
encased [etched prior to use] transponders and are treated as in A. The  
resulting beads are sealed with polystyrene [2 to 5  $\mu$ M] and then coated  
with a selected acceptor molecule, such as an antigen, antibody or  
receptor, to which a radiolabeled ligand or antibody selectively binds.  
25 The identity of the linked peptides or protein is encoded into each  
memory. After reactionn and counting in a liquid scintillation counter, the  
beads that have bound acceptor molecule are read to identify the linked  
protein.



-175-

2. The porous glass beads are replaced with glass encased [etched prior to use] transponders and are treated as in A and sealed as in A with polystyrene. A peptide, small organic or other library is synthesized on the polystyrene surface of each bead, and the identity of each member of the library encoded into the memory. The beads with linked molecules are reacted with labeled receptor and counted in a liquid scintillation counter. After counting in a liquid scintillation counter, the beads that have bound receptor are read to identify the molecule that bound to the receptor.

10

**EXAMPLE 9****Use of the scintillant coated or encased particles in assays**

In experiments 1-3, as model system, the binding of biotin to functional amine groups was detected using  $^{125}\text{I}$ -streptavidin. In experiment 4, the binding of  $[\text{Met}^5]$  enkephalin to the functional amine groups was detected using  $^{125}\text{I}$ -antibody.

15

**Experiment #1**

1. Scintillant [PPO %2 and DPA %0.05] was introduced [Emerald Diagnostics, Eugene, OR] and incorporated on the interior surface of polystyrene beads [Bang Laboratories]. The polystyrene beads were  $3.1 \mu\text{M}$ , with 20% crosslinking and were derivatized with amine groups.

20

2. The concentration of the functional amine groups on the bead surfaces was estimated to be about  $0.04125 \mu\text{mol/mg}$ . The amine groups were covalently linked to the N-hydroxy succinimide derivative of Biotin [Calbiochem 203112] at molecular ratio of 1:10, respectively. This was done by resuspending the beads in a 50% acetonitrile: water, Hepes [pH 8.0] buffered solution containing biotin for 2 hours at room temperature. After 2 hours, the beads were washed 6 times with 10 ml of 50% acetonitrile in water. Beads were resuspended in PBS [pH 7.2] and stored overnight at  $4^\circ \text{C}$ .

30

-176-

3. Using an SPA format, biotin was detected using  $^{125}\text{I}$ -streptavidin to the biotin was detected. This was done by diluting beads to a 20 mg/ml and adding them to 96 well plates at 4, 2, 1, 0.5, 0.25, and 0.125 mg per well. Volumes were adjusted to 100  $\mu\text{l}$  per well.  $^{125}\text{I}$ -streptavidin was added to final concentration of 0.1  $\mu\text{Ci}$  per well. Plates were counted in a Wallac MicroBeta Trilux scintillation counter after 2 hours. Bound biotin was detected.

#### Experiment #2

1. Scintillants [pyrenebutyric acid and 9-anthracenepropionic acid] were covalently linked to the TENTAGEL<sup>®</sup> beads, with 0.25 mmol/g available functional amine groups, at 2%: 0.05% ratio, respectively. The fluorophore was linked to 15% of these sites.

2. The functional amine group on the TENTAGEL<sup>®</sup> beads were covalently linked to the N-hydroxy succinimide derivative of biotin. The free functional amine groups on beads [0.21  $\mu\text{mol}/\text{mg}$ ] were covalently linked to biotin [Calbiochem 203112]. Briefly, Biotin was mixed with the beads at a molecular ratio of 10:1 in 6 ml of 50% acetonitrile with Hepes [pH 8.0] and incubated for 2 hours at room temperature. At the end of incubation period, the beads were washed 3 times with 10 ml of 100% acetonitrile followed by 3 washes with 50% acetonitrile in water. The beads were resuspended in PBS [pH 7.2] and stored overnight at 4<sup>o</sup> C.

3. Biotin was detected using  $^{125}\text{I}$ -streptavidin detected in a SPA format. This was done by diluting beads to a 20 mg/ml, and introducing them into wells in 96 well plats at 4, 2, 1, 0.5, 0.25, and 0.125 mg per well. Volumes were adjusted to 100  $\mu\text{l}$  per well.  $^{125}\text{I}$ -streptavidin [Amersham IM236] was added to each well at a concentration of 0.05  $\mu\text{Ci}/\text{well}$ . After approximately 2 hours, additional  $^{125}\text{I}$ -streptavidin

-177-

was added for a final concentration of 0.1 uCi per well. Plates were counted in a Wallac MicroBeta Trilux scintillation counter after 2 hours. Bound biotin was detected.

### Experiment #3

- 5           1. BMDS chips [and also similar chips ID TAG available from Identification Technologies Inc.] were coated with scintillant [PPO %2 and DPA 0.5% in polystyrene [10% in dichloromethane].
2. The chip was then coated with a layer of derivatized silane.
3. The functional amine groups were covalently linked to the N-  
10 hydroxy succinimide derivative of Biotin. The free functional amine groups on the silane [375 nmol/chip] were covalently linked to Biotin [Calbiochem 203112]. Briefly, biotin was dissolved in 1 ml of 30% acetonitrile with Hepes [pH 8.0] and incubated with the chip for 2 hours at room temperature. At the end of incubation period, the chip  
15 was washed 3 times with 50% acetonitrile in water, resuspended in PBS [pH 7.2] and stored overnight at 4° C.
4. Biotin was detected in a SPA format by <sup>125</sup>I-streptavidin. The chips were placed in 24-well plate with 500  $\mu$ l <sup>125</sup>I-streptavidin [0.1  $\mu$ Ci/well, Amersham IM236]. After a 2 hour incubation, the plates  
20 were counted in Wallac MicroBeta Trilux scintillation counter. Binding was detected.

### Experiment #4

1. The chips were coated with scintillant [PPO %2 and DPA] 0.05% in polystyrene [10% in dichloromethane].
- 25           2. The functional amine group was derivatized for spontaneous covalent binding to amine group [Xenopore, NJ].
3. [Met<sup>5</sup>]Enkephalin [tyr-gly-gly-phe-met; SEQ ID No. 33] peptide [R&D Antibodies] were covalently linked to the amine group by incubating the coated chip with the peptide in 500  $\mu$ l of PBS [160  $\mu$ g peptide/ml,  
30 pH 8]) overnight at room temperature.

-178-

4. At the end of the incubation, the chips were washed and then incubated in 3% bovine serum albumin for 2 hours.

5. Linked peptide was detected in a SPA format. The chips were was placed in 24-well plate containing 500  $\mu$ l of  $^{125}$ I-anti-

5 [Met<sup>5</sup>]Enkephalin antibody [0.1  $\mu$ Ci/well, R&D Antibodies]. The antibody is a rabbit polyclonal against the C-terminal region of the peptide. After a 2 hour incubation, the plates were counted in Wallac MicroBeta Trilux scintillation counter and linked peptide was detected.

10 Since modifications will be apparent to those of skill in this art, it is intended that this invention be limited only by the scope of the appended claims.

-179-

## SEQUENCE LISTING

## (1) GENERAL INFORMATION:

## (i) APPLICANT:

(A) NAME: IRORI  
(B) STREET: 11025 North Torrey Pines, Suite 100  
(C) CITY: La Jolla  
(D) STATE: California  
(E) COUNTRY: USA  
(F) POSTAL CODE (ZIP): 92037

## (i) INVENTOR/APPLICANT:

(A) NAME: Michael P. Nova  
(B) STREET: 16428 La Gracia  
(C) CITY: Rancho Sante Fe  
(D) STATE: California  
(E) COUNTRY: USA  
(F) POSTAL CODE (ZIP): 92067

## (i) INVENTOR/APPLICANT:

(A) NAME: Zahra Parndoosh  
(B) STREET: 4626 Exbury Court  
(C) CITY: San Diego  
(D) STATE: California  
(E) COUNTRY: USA  
(F) POSTAL CODE (ZIP): 92130

## (i) INVENTOR/APPLICANT:

(A) NAME: Andrew E. Senyei  
(B) STREET: 1749 El Camino Del Teatro  
(C) CITY: La Jolla  
(D) STATE: California  
(E) COUNTRY: USA  
(F) POSTAL CODE (ZIP): 92037

## (i) INVENTOR/APPLICANT:

(A) NAME: Gary S. David  
(B) STREET: 9477 Poole Street  
(C) CITY: La Jolla  
(D) STATE: California  
(E) COUNTRY: USA  
(F) POSTAL CODE (ZIP): 92037

(ii) TITLE OF THE INVENTION: ASSAYS USING REMOTELY  
PROGRAMMABLE MATRICES WITH MEMORIES

(iii) NUMBER OF SEQUENCES: 33

## (iv) CORRESPONDENCE ADDRESS:

(A) ADDRESSEE: Brown, Martin, Haller & McClain  
(B) STREET: 1660 Union Street  
(C) CITY: San Diego  
(D) STATE: CA  
(E) COUNTRY: USA  
(F) ZIP: 92101-2926

## (v) COMPUTER READABLE FORM:

(A) MEDIUM TYPE: Diskette  
(B) COMPUTER: IBM Compatible

-180-

- (C) OPERATING SYSTEM: DOS
  - (D) SOFTWARE: FastSEQ Version 1.5
  - (vi) CURRENT APPLICATION DATA:
    - (A) APPLICATION NUMBER:
    - (B) FILING DATE: 04/25/96
    - (C) CLASSIFICATION:
  - (vii) PRIOR APPLICATION DATA:
    - (A) APPLICATION NUMBER:08/
    - (B) FILING DATE: 04/02/96
  - (vii) PRIOR APPLICATION DATA:
    - (A) APPLICATION NUMBER:08/567,746
    - (B) FILING DATE: 12/05/95
  - (vii) PRIOR APPLICATION DATA:
    - (A) APPLICATION NUMBER:08/538,387
    - (B) FILING DATE: 10/03/95
  - (vii) PRIOR APPLICATION DATA:
    - (A) APPLICATION NUMBER:08/473,660
    - (B) FILING DATE: 06/07/95
  - (vii) PRIOR APPLICATION DATA:
    - (A) APPLICATION NUMBER: 08/480,196
    - (B) FILING DATE: 06/07/95
  - (vii) PRIOR APPLICATION DATA:
    - (A) APPLICATION NUMBER: 08/484,504
    - (B) FILING DATE: 06/07/95
  - (vii) PRIOR APPLICATION DATA:
    - (A) APPLICATION NUMBER: 08/484,486
    - (B) FILING DATE: 06/07/95
  - (vii) PRIOR APPLICATION DATA:
    - (A) APPLICATION NUMBER: 08/480,147
    - (B) FILING DATE: 06/07/95
  - (vii) PRIOR APPLICATION DATA:
    - (A) APPLICATION NUMBER: 08/428,662
    - (B) FILING DATE: 04/25/95
  - (viii) ATTORNEY/AGENT INFORMATION:
    - (A) NAME: Seidman, Stephanie L
    - (B) REGISTRATION NUMBER: 33,779
    - (C) REFERENCE/DOCKET NUMBER: 6444-302PC
  - (ix) TELECOMMUNICATION INFORMATION:
    - (A) TELEPHONE: 619-238-0999
    - (B) TELEFAX: 619-238-0062
    - (C) TELEX:
- (2) INFORMATION FOR SEQ ID NO:1:
- (i) SEQUENCE CHARACTERISTICS:
    - (A) LENGTH: 4 amino acids
    - (B) TYPE: amino acid

-181-

(C) STRANDEDNESS: single  
(D) TOPOLOGY: linear

(ii) MOLECULE TYPE: peptide  
(iii) HYPOTHETICAL: NO  
(iv) ANTISENSE: NO  
(v) FRAGMENT TYPE: internal  
(vi) ORIGINAL SOURCE:

(xi) SEQUENCE DESCRIPTION: SEQ ID NO:1:

Leu Ala Gly Asp

1

(2) INFORMATION FOR SEQ ID NO:2:

(i) SEQUENCE CHARACTERISTICS:  
(A) LENGTH: 4 amino acids  
(B) TYPE: amino acid  
(C) STRANDEDNESS: single  
(D) TOPOLOGY: linear

(ii) MOLECULE TYPE: peptide  
(iii) HYPOTHETICAL: NO  
(iv) ANTISENSE: NO  
(v) FRAGMENT TYPE: internal  
(vi) ORIGINAL SOURCE:

(xi) SEQUENCE DESCRIPTION: SEQ ID NO:2:

Leu Glu Gly Asp

1

(2) INFORMATION FOR SEQ ID NO:3:

(i) SEQUENCE CHARACTERISTICS:  
(A) LENGTH: 4 amino acids  
(B) TYPE: amino acid  
(C) STRANDEDNESS: single  
(D) TOPOLOGY: linear

(ii) MOLECULE TYPE: peptide  
(iii) HYPOTHETICAL: NO  
(iv) ANTISENSE: NO  
(v) FRAGMENT TYPE: internal  
(vi) ORIGINAL SOURCE:

(xi) SEQUENCE DESCRIPTION: SEQ ID NO:3:

Ser Ala Gly Asp

1

(2) INFORMATION FOR SEQ ID NO:4:

(i) SEQUENCE CHARACTERISTICS:  
(A) LENGTH: 4 amino acids  
(B) TYPE: amino acid  
(C) STRANDEDNESS: single  
(D) TOPOLOGY: linear

-182-

(ii) MOLECULE TYPE: peptide  
(iii) HYPOTHETICAL: NO  
(iv) ANTISENSE: NO  
(v) FRAGMENT TYPE: internal  
(vi) ORIGINAL SOURCE:

(xi) SEQUENCE DESCRIPTION: SEQ ID NO:4:

Ser Glu Gly Asp

1

(2) INFORMATION FOR SEQ ID NO:5:

(i) SEQUENCE CHARACTERISTICS:  
(A) LENGTH: 4 amino acids  
(B) TYPE: amino acid  
(C) STRANDEDNESS: single  
(D) TOPOLOGY: linear

(ii) MOLECULE TYPE: peptide  
(iii) HYPOTHETICAL: NO  
(iv) ANTISENSE: NO  
(v) FRAGMENT TYPE: internal  
(vi) ORIGINAL SOURCE:

(xi) SEQUENCE DESCRIPTION: SEQ ID NO:5:

Leu Ala Val Asp

1

(2) INFORMATION FOR SEQ ID NO:6:

(i) SEQUENCE CHARACTERISTICS:  
(A) LENGTH: 4 amino acids  
(B) TYPE: amino acid  
(C) STRANDEDNESS: single  
(D) TOPOLOGY: linear

(ii) MOLECULE TYPE: peptide  
(iii) HYPOTHETICAL: NO  
(iv) ANTISENSE: NO  
(v) FRAGMENT TYPE: internal  
(vi) ORIGINAL SOURCE:

(xi) SEQUENCE DESCRIPTION: SEQ ID NO:6:

Leu Glu Val Asp

1

(2) INFORMATION FOR SEQ ID NO:7:

(i) SEQUENCE CHARACTERISTICS:  
(A) LENGTH: 4 amino acids  
(B) TYPE: amino acid  
(C) STRANDEDNESS: single  
(D) TOPOLOGY: linear

(ii) MOLECULE TYPE: peptide  
(iii) HYPOTHETICAL: NO  
(iv) ANTISENSE: NO



-183-

(v) FRAGMENT TYPE: internal  
(vi) ORIGINAL SOURCE:

(xi) SEQUENCE DESCRIPTION: SEQ ID NO:7:

Ser Ala Val Asp

1

(2) INFORMATION FOR SEQ ID NO:8:

(i) SEQUENCE CHARACTERISTICS:

(A) LENGTH: 4 amino acids  
(B) TYPE: amino acid  
(C) STRANDEDNESS: single  
(D) TOPOLOGY: linear

(ii) MOLECULE TYPE: peptide

(iii) HYPOTHETICAL: NO

(iv) ANTISENSE: NO

(v) FRAGMENT TYPE: internal

(vi) ORIGINAL SOURCE:

(xi) SEQUENCE DESCRIPTION: SEQ ID NO:8:

Ser Glu Val Asp

1

(2) INFORMATION FOR SEQ ID NO:9:

(i) SEQUENCE CHARACTERISTICS:

(A) LENGTH: 4 amino acids  
(B) TYPE: amino acid  
(C) STRANDEDNESS: single  
(D) TOPOLOGY: linear

(ii) MOLECULE TYPE: peptide

(iii) HYPOTHETICAL: NO

(iv) ANTISENSE: NO

(v) FRAGMENT TYPE: internal

(vi) ORIGINAL SOURCE:

(xi) SEQUENCE DESCRIPTION: SEQ ID NO:9:

Leu Ala Gly Phe

1

(2) INFORMATION FOR SEQ ID NO:10:

(i) SEQUENCE CHARACTERISTICS:

(A) LENGTH: 4 amino acids  
(B) TYPE: amino acid  
(C) STRANDEDNESS: single  
(D) TOPOLOGY: linear

(ii) MOLECULE TYPE: peptide

(iii) HYPOTHETICAL: NO

(iv) ANTISENSE: NO

(v) FRAGMENT TYPE: internal

(vi) ORIGINAL SOURCE:

-184-

(xi) SEQUENCE DESCRIPTION: SEQ ID NO:10:

Leu Glu Gly Phe

1

(2) INFORMATION FOR SEQ ID NO:11:

(i) SEQUENCE CHARACTERISTICS:

- (A) LENGTH: 4 amino acids
- (B) TYPE: amino acid
- (C) STRANDEDNESS: single
- (D) TOPOLOGY: linear

(ii) MOLECULE TYPE: peptide

(iii) HYPOTHETICAL: NO

(iv) ANTISENSE: NO

(v) FRAGMENT TYPE: internal

(vi) ORIGINAL SOURCE:

(xi) SEQUENCE DESCRIPTION: SEQ ID NO:11:

Ser Ala Gly Phe

1

(2) INFORMATION FOR SEQ ID NO:12:

(i) SEQUENCE CHARACTERISTICS:

- (A) LENGTH: 4 amino acids
- (B) TYPE: amino acid
- (C) STRANDEDNESS: single
- (D) TOPOLOGY: linear

(ii) MOLECULE TYPE: peptide

(iii) HYPOTHETICAL: NO

(iv) ANTISENSE: NO

(v) FRAGMENT TYPE: internal

(vi) ORIGINAL SOURCE:

(xi) SEQUENCE DESCRIPTION: SEQ ID NO:12:

Ser Glu Gly Phe

1

(2) INFORMATION FOR SEQ ID NO:13:

(i) SEQUENCE CHARACTERISTICS:

- (A) LENGTH: 4 amino acids
- (B) TYPE: amino acid
- (C) STRANDEDNESS: single
- (D) TOPOLOGY: linear

(ii) MOLECULE TYPE: peptide

(iii) HYPOTHETICAL: NO

(iv) ANTISENSE: NO

(v) FRAGMENT TYPE: internal

(vi) ORIGINAL SOURCE:

(xi) SEQUENCE DESCRIPTION: SEQ ID NO:13:

Leu Ala Val Phe

1

-185-

## (2) INFORMATION FOR SEQ ID NO:14:

## (i) SEQUENCE CHARACTERISTICS:

- (A) LENGTH: 4 amino acids
- (B) TYPE: amino acid
- (C) STRANDEDNESS: single
- (D) TOPOLOGY: linear

(ii) MOLECULE TYPE: peptide

(iii) HYPOTHETICAL: NO

(iv) ANTISENSE: NO

(v) FRAGMENT TYPE: internal

(vi) ORIGINAL SOURCE:

(xi) SEQUENCE DESCRIPTION: SEQ ID NO:14:

Leu Glu Val Phe

1

## (2) INFORMATION FOR SEQ ID NO:15:

## (i) SEQUENCE CHARACTERISTICS:

- (A) LENGTH: 4 amino acids
- (B) TYPE: amino acid
- (C) STRANDEDNESS: single
- (D) TOPOLOGY: linear

(ii) MOLECULE TYPE: peptide

(iii) HYPOTHETICAL: NO

(iv) ANTISENSE: NO

(v) FRAGMENT TYPE: internal

(vi) ORIGINAL SOURCE:

(xi) SEQUENCE DESCRIPTION: SEQ ID NO:15:

Ser Ala Val Phe

1

## (2) INFORMATION FOR SEQ ID NO:16:

## (i) SEQUENCE CHARACTERISTICS:

- (A) LENGTH: 4 amino acids
- (B) TYPE: amino acid
- (C) STRANDEDNESS: single
- (D) TOPOLOGY: linear

(ii) MOLECULE TYPE: peptide

(iii) HYPOTHETICAL: NO

(iv) ANTISENSE: NO

(v) FRAGMENT TYPE: internal

(vi) ORIGINAL SOURCE:

(xi) SEQUENCE DESCRIPTION: SEQ ID NO:16:

Ser Glu Val Phe

1

## (2) INFORMATION FOR SEQ ID NO:17:

## (i) SEQUENCE CHARACTERISTICS:

- (A) LENGTH: 4 amino acids

-186-

- (B) TYPE: amino acid
- (C) STRANDEDNESS: single
- (D) TOPOLOGY: linear

- (ii) MOLECULE TYPE: peptide
- (iii) HYPOTHETICAL: NO
- (iv) ANTISENSE: NO
- (v) FRAGMENT TYPE: internal
- (vi) ORIGINAL SOURCE:

(xi) SEQUENCE DESCRIPTION: SEQ ID NO:17:

Leu Ala Gly Lys

1

(2) INFORMATION FOR SEQ ID NO:18:

- (i) SEQUENCE CHARACTERISTICS:
  - (A) LENGTH: 4 amino acids
  - (B) TYPE: amino acid
  - (C) STRANDEDNESS: single
  - (D) TOPOLOGY: linear

- (ii) MOLECULE TYPE: peptide
- (iii) HYPOTHETICAL: NO
- (iv) ANTISENSE: NO
- (v) FRAGMENT TYPE: internal
- (vi) ORIGINAL SOURCE:

(xi) SEQUENCE DESCRIPTION: SEQ ID NO:18:

Leu Glu Gly Lys

1

(2) INFORMATION FOR SEQ ID NO:19:

- (i) SEQUENCE CHARACTERISTICS:
  - (A) LENGTH: 4 amino acids
  - (B) TYPE: amino acid
  - (C) STRANDEDNESS: single
  - (D) TOPOLOGY: linear

- (ii) MOLECULE TYPE: peptide
- (iii) HYPOTHETICAL: NO
- (iv) ANTISENSE: NO
- (v) FRAGMENT TYPE: internal
- (vi) ORIGINAL SOURCE:

(xi) SEQUENCE DESCRIPTION: SEQ ID NO:19:

Ser Ala Gly Lys

1

(2) INFORMATION FOR SEQ ID NO:20:

- (i) SEQUENCE CHARACTERISTICS:
  - (A) LENGTH: 4 amino acids
  - (B) TYPE: amino acid
  - (C) STRANDEDNESS: single
  - (D) TOPOLOGY: linear

-187-

- (ii) MOLECULE TYPE: peptide
  - (iii) HYPOTHETICAL: NO
  - (iv) ANTISENSE: NO
  - (v) FRAGMENT TYPE: internal
  - (vi) ORIGINAL SOURCE:
- (xi) SEQUENCE DESCRIPTION: SEQ ID NO:20:

Ser Glu Gly Lys

1

## (2) INFORMATION FOR SEQ ID NO:21:

- (i) SEQUENCE CHARACTERISTICS:
    - (A) LENGTH: 4 amino acids
    - (B) TYPE: amino acid
    - (C) STRANDEDNESS: single
    - (D) TOPOLOGY: linear
  - (ii) MOLECULE TYPE: peptide
  - (iii) HYPOTHETICAL: NO
  - (iv) ANTISENSE: NO
  - (v) FRAGMENT TYPE: internal
  - (vi) ORIGINAL SOURCE:
- (xi) SEQUENCE DESCRIPTION: SEQ ID NO:21:

Leu Ala Val Lys

1

## (2) INFORMATION FOR SEQ ID NO:22:

- (i) SEQUENCE CHARACTERISTICS:
    - (A) LENGTH: 4 amino acids
    - (B) TYPE: amino acid
    - (C) STRANDEDNESS: single
    - (D) TOPOLOGY: linear
  - (ii) MOLECULE TYPE: peptide
  - (iii) HYPOTHETICAL: NO
  - (iv) ANTISENSE: NO
  - (v) FRAGMENT TYPE: internal
  - (vi) ORIGINAL SOURCE:
- (xi) SEQUENCE DESCRIPTION: SEQ ID NO:22:

Leu Glu Val Lys

1

## (2) INFORMATION FOR SEQ ID NO:23:

- (i) SEQUENCE CHARACTERISTICS:
  - (A) LENGTH: 4 amino acids
  - (B) TYPE: amino acid
  - (C) STRANDEDNESS: single
  - (D) TOPOLOGY: linear
- (ii) MOLECULE TYPE: peptide
- (iii) HYPOTHETICAL: NO
- (iv) ANTISENSE: NO

-188-

- (v) FRAGMENT TYPE: internal
- (vi) ORIGINAL SOURCE:

(xi) SEQUENCE DESCRIPTION: SEQ ID NO:23:

Ser Ala Val Lys

1

(2) INFORMATION FOR SEQ ID NO:24:

- (i) SEQUENCE CHARACTERISTICS:
  - (A) LENGTH: 4 amino acids
  - (B) TYPE: amino acid
  - (C) STRANDEDNESS: single
  - (D) TOPOLOGY: linear
- (ii) MOLECULE TYPE: peptide
- (iii) HYPOTHETICAL: NO
- (iv) ANTISENSE: NO
- (v) FRAGMENT TYPE: internal
- (vi) ORIGINAL SOURCE:

(xi) SEQUENCE DESCRIPTION: SEQ ID NO:24:

Ser Glu Val Lys

1

(2) INFORMATION FOR SEQ ID NO:25:

- (i) SEQUENCE CHARACTERISTICS:
  - (A) LENGTH: 10 amino acids
  - (B) TYPE: amino acid
  - (C) STRANDEDNESS: single
  - (D) TOPOLOGY: linear
- (ii) MOLECULE TYPE: peptide
- (iii) HYPOTHETICAL: NO
- (iv) ANTISENSE: NO
- (v) FRAGMENT TYPE: internal
- (vi) ORIGINAL SOURCE:

(xi) SEQUENCE DESCRIPTION: SEQ ID NO:25:

Met Leu Asp Ser Ile Trp Lys Pro Asp Leu

1

5

10

(2) INFORMATION FOR SEQ ID NO:26:

- (i) SEQUENCE CHARACTERISTICS:
  - (A) LENGTH: 10 amino acids
  - (B) TYPE: amino acid
  - (C) STRANDEDNESS: single
  - (D) TOPOLOGY: linear
- (ii) MOLECULE TYPE: peptide
- (iii) HYPOTHETICAL: NO
- (iv) ANTISENSE: NO
- (v) FRAGMENT TYPE: internal
- (vi) ORIGINAL SOURCE:

-189-

(xi) SEQUENCE DESCRIPTION: SEQ ID NO:26:

Met Leu Asp Ser Gly Trp Lys Pro Asp Leu  
1 5 10

(2) INFORMATION FOR SEQ ID NO:27:

(i) SEQUENCE CHARACTERISTICS:

- (A) LENGTH: 10 amino acids
- (B) TYPE: amino acid
- (C) STRANDEDNESS: single
- (D) TOPOLOGY: linear

(ii) MOLECULE TYPE: peptide

(iii) HYPOTHETICAL: NO

(iv) ANTISENSE: NO

(v) FRAGMENT TYPE: internal

(vi) ORIGINAL SOURCE:

(xi) SEQUENCE DESCRIPTION: SEQ ID NO:27:

Met Leu Asp Ser Ile Trp Lys Pro Asp Ala  
1 5 10

(2) INFORMATION FOR SEQ ID NO:28:

(i) SEQUENCE CHARACTERISTICS:

- (A) LENGTH: 10 amino acids
- (B) TYPE: amino acid
- (C) STRANDEDNESS: single
- (D) TOPOLOGY: linear

(ii) MOLECULE TYPE: peptide

(iii) HYPOTHETICAL: NO

(iv) ANTISENSE: NO

(v) FRAGMENT TYPE: internal

(vi) ORIGINAL SOURCE:

(xi) SEQUENCE DESCRIPTION: SEQ ID NO:28:

Met Leu Asp Ser Ile Trp Lys Phe Asp Leu  
1 5 10

(2) INFORMATION FOR SEQ ID NO:29:

(i) SEQUENCE CHARACTERISTICS:

- (A) LENGTH: 10 amino acids
- (B) TYPE: amino acid
- (C) STRANDEDNESS: single
- (D) TOPOLOGY: linear

(ii) MOLECULE TYPE: peptide

(iii) HYPOTHETICAL: NO

(iv) ANTISENSE: NO

(v) FRAGMENT TYPE: internal

(vi) ORIGINAL SOURCE:

(xi) SEQUENCE DESCRIPTION: SEQ ID NO:29:

Met Leu Asp Ser Gly Trp Lys Phe Asp Leu  
1 5 10

-190-

(2) INFORMATION FOR SEQ ID NO:30:

(i) SEQUENCE CHARACTERISTICS:

- (A) LENGTH: 10 amino acids
- (B) TYPE: amino acid
- (C) STRANDEDNESS: single
- (D) TOPOLOGY: linear

(ii) MOLECULE TYPE: peptide

(iii) HYPOTHETICAL: NO

(iv) ANTISENSE: NO

(v) FRAGMENT TYPE: internal

(vi) ORIGINAL SOURCE:

(xi) SEQUENCE DESCRIPTION: SEQ ID NO:30:

Met Leu Asp Ser Gly Trp Lys Pro Asp Ala  
1 5 10

(2) INFORMATION FOR SEQ ID NO:31:

(i) SEQUENCE CHARACTERISTICS:

- (A) LENGTH: 10 amino acids
- (B) TYPE: amino acid
- (C) STRANDEDNESS: single
- (D) TOPOLOGY: linear

(ii) MOLECULE TYPE: peptide

(iii) HYPOTHETICAL: NO

(iv) ANTISENSE: NO

(v) FRAGMENT TYPE: internal

(vi) ORIGINAL SOURCE:

(xi) SEQUENCE DESCRIPTION: SEQ ID NO:31:

Met Leu Asp Ser Ile Trp Lys Phe Asp Ala  
1 5 10

(2) INFORMATION FOR SEQ ID NO:32:

(i) SEQUENCE CHARACTERISTICS:

- (A) LENGTH: 10 amino acids
- (B) TYPE: amino acid
- (C) STRANDEDNESS: single
- (D) TOPOLOGY: linear

(ii) MOLECULE TYPE: peptide

(iii) HYPOTHETICAL: NO

(iv) ANTISENSE: NO

(v) FRAGMENT TYPE: internal

(vi) ORIGINAL SOURCE:

(xi) SEQUENCE DESCRIPTION: SEQ ID NO:32:

Met Leu Asp Ser Gly Trp Lys Phe Asp Ala  
1 5 10



-191-

(2) INFORMATION FOR SEQ ID NO:33:

(i) SEQUENCE CHARACTERISTICS:

- (A) LENGTH: 5 amino acids
- (B) TYPE: amino acid
- (C) STRANDEDNESS: single
- (D) TOPOLOGY: linear

(ii) MOLECULE TYPE: peptide

(iii) HYPOTHETICAL: NO

(iv) ANTISENSE: NO

(v) FRAGMENT TYPE: internal

(vi) ORIGINAL SOURCE:

(xi) SEQUENCE DESCRIPTION: SEQ ID NO:33:

Tyr Gly Gly Phe Met  
1 5

-192-

**WHAT IS CLAIMED:**

1. A combination of a matrix with memory, comprising:
  - (A) a recording device, comprising a data storage unit; and
  - (B) a matrix material, wherein:
    - 5 the device is less than about 20 mm<sup>3</sup> in size;
    - the matrix material is either comprised of particles of a size such that at least one dimension is no more than about 10 mm or the matrix material is in the form of a container or solid surface used for chemical syntheses.
- 10 2. A combination of a matrix with memory, comprising:
  - (A) a recording device, comprising a data storage unit; and
  - (B) a matrix material, wherein:
    - 15 the matrix material is either comprised of particles of a size such that at least one dimension is no more than about 10 mm or the matrix material is in the form of a container or solid surface used for chemical syntheses; and
    - the matrix is tagged with an identifying mark.
- 20 3. The combination of claim 1 or claim 2, wherein the matrix is derivatized for linking biological particles or molecules.
4. The combination of any of claims 1-3, wherein the device contains a volatile or non-volatile memory.
5. The combination of claim 1 or claim 3, comprising one recording device and a plurality of matrix particles.
6. The combination of claim 2, wherein the mark is an
  - 25 alphanumeric code or a bar code.
7. The combination of any of claims 1-6, further comprising a porous inert shell surrounding the device and particles.
8. The combination of any of claims 1, 3-5 and 7, wherein the data storage unit is electromagnetically remotely programmable.

-193-

9. The combination of any of claims 1, 3-5, 7 and 8, wherein the data storage unit is electromagnetically remotely readable.
10. The combination of any of claims 1-9, further comprising a molecule, a biological particle, a mixture of molecules, a mixture of
- 5 biological particles or a mixture of molecules and biological particles.
11. The combination of claim 7, comprising the microvessel of FIGURES 11-13.
12. The combination of claim 7, comprising the microvessel of FIGURE 14-16.
- 10 13. The microvessel of FIGURES 11-13.
14. The microvessel of FIGURES 14-16.
15. The combination any of claims 1, 3-5, 7 and 8-14, wherein the device is about  $10 \text{ mm}^3$  or less in size.
16. The combination of any of claims 1, 3-5, 7 and 8-14,
- 15 wherein the device is about  $5 \text{ mm}^3$  or less in size.
17. The combination of any of claims 1, 3-5, 7 and 8-16, wherein the matrix comprises a plurality of particles.
18. The combination of claim 17, wherein each particle is about  $50 \mu\text{m}$  in its largest dimension or smaller.
- 20 19. The combination of any of claims 1-18, further comprising luminescent moieties associated with the matrix.
20. The combination any of claims 1-19, wherein the recording device, comprises:
- 25 a memory device having a memory means for storing a plurality of data points and means for receiving a transmitted write signal so that the write signal causes a stored data point corresponding to the data signal to be stored within the memory means.

-194-

21. The combination of claim 22, further comprising a photodetector.

22. The combination of claim 20, wherein the memory means are non-volatile or volatile.

5 23. The combination of claim 20, wherein:

the memory device further comprises a plurality of memory address locations defined therein; and

each of the memory address locations is uniquely addressable for storing the plurality of data points.

10 24. The combination of claim 20, wherein the recording device further comprises an antenna for receiving transmitted electromagnetic radiation.

25. The combination of claim 20, wherein:

15 the memory device further comprises an optical recording medium having a plurality of unique recording locations therein; and each of plurality of unique recording locations is uniquely addressable for storing the plurality of data points.

20 26. The combination of claim 25, wherein the memory device comprises a shell for enclosing the optical recording medium, the shell comprising a material that is inert with respect to the optical recording medium, and is transmissive of an optical signal.

27. The combination of claim 25, wherein each of the plurality of unique recording locations comprises a spectral hole corresponding to a unique wavelength of light.

25 28. The combination of any of claims 1-27, wherein the matrix material is continuous and is in the form of a container, which contains one or more recording device(s) impregnated in the matrix or inside the container, wherein the container is transmissive of at least a portion the electromagnetic spectrum, and the portion includes at least visible light,  
30 infrared light, radio frequencies, ultraviolet light or other light.

-195-

29. The combination of claim 28, wherein the container is a plate with a plurality of wells, in which one or more of the wells contain the recording device, or is a test tube, culture dish, or vial or beaker.

30. The combination of claim 28, wherein the container is in the  
5 form of a cube or other geometrical shape in which the outer surface has been treated for linkage of biological particles or molecules.

31. The combination of claim 30, wherein at least one face or side of the container has an identification code or mark thereon, and the memory is remote from the container.

10 32. The combination of claim 29, wherein the container is a microvessel, test tube, culture dish, or vial or beaker.

33. The combination of claim 20, wherein the recording device further comprises a shell for enclosing the memory device, the shell comprising a material that is inert with respect to the memory device, and  
15 transmissive of the electromagnetic signal.

34. The combination of claim 33, wherein the shell is glass or a plastic polymer.

35. The combination of any of claims 28-34, wherein the matrix material comprises luminescent moieties.

20 36. The combination of claim 1, wherein the recording device is encased in the matrix material.

37. The combination of claim 1, wherein the matrix is a particle and the combination further comprises a plurality of such particles linked to or proximate to one recording device.

25 38. The combination of claim 1, wherein at least one surface of the recording device is coated with the matrix material.

39. The combination of any of claims 1-38, further comprising a molecule or a biological particle in contact with the matrix.

-196-

40. The combination of any of claims 1-39, wherein the matrix material is selected from among a polystyrene, a cellulose, a glass, a polyacrylamide, a polysaccharide, a rubber, silicon, a plastic, sand, pumice, agarose, halogenated hydrocarbon polymers, polyvinyltoluene,  
5 and any polymer used as a matrix in solid phase syntheses.

41. A composition, comprising one or more of the combinations of any of claims 1-40, wherein the matrix is comprised of particles and each particle or a plurality of particles is in physical contact with a recording device.

10 42. A device for use in scintillation proximity assays or non-radioactive energy transfer proximity assays, comprising a combination of and of claims 1-40, wherein the matrix comprises luminescent moieties.

43. The device of claim 42, wherein the luminescent moieties are selected from among fluophors.

15 44. The device of claim 42, wherein the luminescent moieties are selected from among 2,5-diphenyloxazole [PPO], anthracene, 2-(4'-tert-butylphenyl)-5-(4"-biphenyl)-1,3,4-oxadiazole [butyl-PBD]; 1-phenyl-3-mesityl-2-pyrazoline [PMP], with or without frequency shifters, such as 1,4,-bis[5-phenyl(oxazolyl)benzene] [POPOP]; *p*-bis-*o*-methyl-  
20 styrylbenzene [bis-MSB].

45. The device of claim 43, wherein the luminescent moieties are selected from among rare earth metal cryptate allophycocyanin (APC), allophycocyanin B, phycocyanin C or phycocyanin R, a rhodamine, thiomine, phycocyanin R, phycoerythrocyanin, phycoerythrin C,  
25 phycoerythrin B, phycoerythrin R .

46. The device of claim 43, wherein the luminescent moieties are selected from among Eu trisbipyridine diamine (EuTBP) and Tb tribipyridine diamine (TbTBP).

-197-

47. A reagent, comprising a combination of claim 1 or claim 2, wherein the matrix contains scintillating material, whereby the reagent can be used in a scintillation proximity assay (SPA).

48. The reagent of claim 47, wherein the scintillating material is  
5 selected from the group consisting of doped glass and calcium fluoride.

49. The reagent of claim 47, wherein the scintillating material is yttrium silicate.

50. The reagent of claim 47, wherein the dopant is selected from the group consisting of Mn, Cu, Pb, Sn, Au, Ag, Sm and Ce.

10 51. The reagent of claim 50, wherein the glass includes from about 0.1 to about 10% by weight of an inorganic salt of the dopant.

52. The reagent of claim 47, further comprising a molecule or biological particle linked to the matrix.

15 53. The reagent of claim 52, wherein the molecule is a protein, peptide, or nucleic acid.

54. The reagent of claim 52, wherein the biological particle is a phage, prokaryotic cell or eukaryotic cell.

20 55. In a scintillation proximity bead, the improvement comprising including a recording device in the contact with the bead that contains the scintillant.

56. In a non-radioactive energy transfer proximity assay, the improvement comprising adding a combination of any of claims 1-40 to the assay, wherein the combination comprises at least one fluorescent moiety.

25 57. A method for electromagnetically tagging molecules or biological particles, comprising contacting the molecules or biological particles with the combination of claim 1, wherein the contacting is effected by placing the molecules in proximity to the combination or by placing the combination in physical contact with the molecules or  
30 biological particles.

-198-

58. A method for electromagnetically tagging molecules or biological particles, comprising:

contacting the molecules with a recording device that includes a memory device having a memory means for storing a plurality of data points and means for receiving a transmitted electromagnetic signal so  
5 that a write signal causes a stored data point corresponding to the data signal to be stored within the memory means; and

transmitting an electromagnetic signal to the device, whereby a data point is stored within the memory means.

10 59. The method of claim 58, wherein the process of contacting and transmitting of a data point is repeated as plurality of times with additional molecules biological particles and recording devices to produce a plurality of electronically tagged molecules or biological particles.

60. The method of claim 58, wherein the process is automated.

15 61. A method for electromagnetically tagging a support matrix, comprising contacting the matrix material with a recording device, wherein the contact may be direct or may be effected indirectly.

62. The method of claim 61, wherein:

the recording device includes a data storage unit having memory  
20 means for storing a plurality of data points and means for receiving a transmitted electromagnetic signal so that a write signal causes a stored data point corresponding to the data signal to be stored within the memory means.

25 63. The method of claim 62, wherein the memory means are volatile or non-volatile.

64. The method of claim 62, wherein:

the recording device includes a data storage unit includes a memory device having an optical recording medium for storing a plurality of data points and means for receiving a projected optical signal having a  
30 first intensity for forming a plurality of spectral holes in the optical



-199-

recording medium, wherein each spectral hole of the plurality of spectral holes corresponds to a stored data point.

65. The method of claim 64, wherein the projected optical signal has a second intensity for reading the stored data point by detecting the  
5 presence of each spectral hole in the optical recording medium.

66. A method for electromagnetically tagging molecules or biological particles during synthesis, comprising:

linking the molecules to a combination of claim 1;

transmitting an electromagnetic signal to the memory in the  
10 combination with linked molecules, whereby a data point that identifies the linked molecule is stored within the memory;

linking a second molecule to the first linked molecule;

transmitting an electromagnetic signal to the memory in the  
combination with linked molecules, whereby a data point that identifies  
15 the second linked molecule is stored within the memory; and

repeating this process a plurality of times, until the synthesis is complete.

67. The method of claim 66, further comprising screening the resulting compounds for activity or analyzing the structure of the  
20 resulting compounds or assessing the activity of the resulting compounds.

68. The method of claim 66 or claim 67, wherein the synthesized product is a peptide and each added molecule is an amino acid.

25 69. The method of claim 66 or claim 67, wherein the synthesized product is an oligonucleotide and each added molecule is an nucleotide.

70. The method of claim 66 or claim 67, wherein the synthesized product is an oligomer and each added molecule is a monomer.

-200-

71. The method of claim 66 or claim 67, wherein the synthesized product is an organic molecule and each added molecule is a substituent on the organic molecule.

72. The method of any of claims 66-71, further comprising  
5 repeating the process a plurality of times to produce a library of tagged molecules.

73. The method of any of claims 66-72, wherein the matrix comprises a luminescent moiety.

74. A method for identifying or tracking molecules and biological  
10 particles, comprising:

programming a recording device linked to or in contact with or in proximity to a the molecule or biological particle with one or more indicators representative of the identity of the molecule or biological particle, or physical or chemical properties of the molecule or biological  
15 particle, or other identifying information for tracking the molecule or biological particle.

75. The method of claim 74, further comprising:  
exposing the recording device to electromagnetic radiation; and  
transmitting to a host computer or decoder/encoder instrument the  
20 indicator(s) representative of the identity of the molecule or biological particle, or physical or chemical properties of the molecule or biological particle, or other identifying information for tracking the molecule or biological particle.

76. The method of claim 74 or claim 75, wherein the matrix  
25 comprises a luminescent moiety.

77. A method for detecting the occurrence of a reaction, comprising: contacting one reactant in the reaction with a combination of claim 1, wherein the recording device, which further comprises means

-201-

to detect occurrence of the reaction and record the occurrence in the memory of the recording device, detects occurrence of the reaction of the reactant.

78. The method of claim 77, wherein the matrix further comprises  
5 luminescent moieties.

79. The method of claim 77 or claim 78, wherein:

the reaction produces a change in ion concentration in the medium that is detected by the means to detect occurrence of the reaction, which comprises a sensor that detects changes in ion concentration.

10 80. A system for programming and reading data from a memory device, comprising:

(a) a host computer or decoder/encoder instrument having a memory for storing data:

15 (i) relating to one or a plurality of process steps, to the identity of a molecule or biological particle, or information categorizing the molecule or biological particle;

(ii) identifying one or a plurality of unique indicators representative of each of the process steps or the identity or category of a molecule or biological particle; and

20 (iii) for generating a data signal representative of each unique indicator;

(b) a transmitter means for receiving a data signal and generating a transmitted signal for transmitting a data signal, and for providing a write signal;

25 (c) a recording device in proximity to or in contact with a solution containing a molecule or a biological particle or in contact with a molecule or biological particle, the recording device comprising:

-202-

a memory device having a memory means for storing a plurality of data points and means for receiving the transmitted signal so that the write signal causes a stored data point corresponding to the data signal to be stored within the memory means;

5

a shell for enclosing the memory device, the shell comprising a material that is non-reactive with and impervious to each of the plurality of process steps or the solution, and inert with respect to the memory device, the material further being transmissive of signals transmitted by the transmitter means;

10

and

(d) means for reading from the memory device to identify each of the stored data points, wherein the stored data points indicate exposure of the device to one of a combination of process steps or the identity or category of the molecule or biological particle.

15

81. The system of claim 80, wherein the memory means is non-volatile.

82. The system of claim 80, wherein the memory means is volatile.

20

83. The system of any of claims 80-82, further comprising a photodetector for detecting any electromagnetic emissions that occur by virtue of reaction between the linked or proximate molecule or biological particle with another molecule or biological particle.

25

84. The system of claim 80 that is for recording and reading data indicative of exposure of a recording device to a combination of process steps selected from a plurality of process steps, wherein the process steps of the plurality are combined and/or performed in a variable order, the system comprising:

30

the host computer or decoder/encoder instrument having a memory for storing data relating to the plurality of process steps identifies a first

-203-

unique indicator representative of a first of the combination of process steps and generates a first data signal representative of the first unique indicator;

the transmitter means receiving the first data signal and generating  
5 a first transmitted signal for transmitting the first data signal, and for providing a write signal;

the host computer or decoder/encoder instrument further identifying at least one second unique indicator representative of at least one second process step of the combination of process steps and  
10 generating at least one second data signal; and

the transmitter means further receiving the at least one second data signal and generating at least one second transmitted signal, and providing the write signal, wherein the memory device further receives the at least one second transmitted signal and stores at least one second  
15 stored data point corresponding thereto; and

means for reading from the memory device to identify each of the stored data points, wherein the stored data points indicate exposure of the device to the combination of process steps.

85. The system of claim 80, further comprising at least one  
20 support matrix disposed on an outer surface of the shell for retaining products of each of the combination of process steps, the at least one support matrix is non-reactive with the plurality of process steps;

86. The system of claim 80, wherein the memory means comprises an electrically-programmable read-only memory having a  
25 plurality of unique addresses.

87. The system of claim 80, wherein the memory means comprises an optically-programmable memory having a plurality of unique addresses.

-204-

88. A system of claim 83, wherein the transmitter means comprises a radio frequency transmitter and the means for receiving each of the first transmitted signal and the at least one second transmitted signal comprises a radio frequency antenna.

5 89. The system of claim 84, wherein the transmitter means comprises a modulated light source and the means for receiving each of the first transmitted signal and the at least one second transmitted signal comprise a photocell.

10 90. A system of claim 80, comprising the program/read station configured as in FIGURE 17.

91. The system of any of claims 80-90, further comprising an apparatus for separating a single recording device from a plurality of recording devices to facilitate writing to and reading from the single recording device, the apparatus, comprising:

15 a funnel means attached to the vessel, the funnel means having an exit in the constriction opening of a diameter sufficient to permit only one recording device to pass through the opening;

20 a tube connected to a first end of the exit opening of the funnel means for receiving the single recording device, the tube having a diameter substantially equal to the constriction diameter;

a means for determining a presence of the single recording device in the tube for providing an activation signal for controlling the transmitter means; and

25 at least one receiving vessel connected at a second end of the tube for receiving the single memory device.

92. The system of claim 80, wherein the transmitter means comprises at least one laser for emitting light at a plurality of unique wavelengths and at least two intensity levels, and the memory device comprises an optical recording medium for recording a spectral hole

-205-

corresponding to each of the plurality of wavelengths, wherein each of the first data signal and the at least one second data signal corresponds to a different unique wavelength of the plurality of unique wavelengths and wherein the write signal is provided by the at least one laser emitting  
5 light at a first intensity level of the at least two intensity levels above a pre-determined write threshold of the optical recording medium.

93. The system of claim 92, wherein the means for reading comprises the at least one laser emitting light at a second intensity level of the at least two intensity levels less than the pre-determined write  
10 threshold of the optical recording medium and an optical detector disposed for receiving light transmitted through or reflected by the spectral hole corresponding to the unique wavelength at which the spectral hole was recorded.

94. The system of claim 93, wherein the shell further comprises  
15 a luminescent moiety or is coated or contacted with a composition comprising a luminescent moiety.

95. A container, comprising a recording device, wherein:  
the container is less than about 10 ml in volume or  
comprises a plurality of wells, each being about 1 ml or less in volume;  
20 the container is transmissive to electromagnetic radiation selected from radio frequencies, infrared wavelengths, ultraviolet wavelengths, microwave frequencies, visible wavelengths or laser light;  
the recording device comprises a memory device having a  
memory means for storing a plurality of data points and means for  
25 receiving the transmitted signal so that the write signal causes a stored data point corresponding to the data signal to be stored within the memory means;

-206-

- the recording device is about 20 mm<sup>3</sup> in size or less;  
the recording device is remotely programmable using  
electromagnetic radiation; and  
the recording device is in contact with or close proximity to  
5 the container; and  
at least one surface of the container is treated to permit  
linkage of biological particles or molecules.
96. The container of claim 95 that has been radiation grafted  
with monomers to produce at least one surface to which molecules or  
10 biological molecules can be bound.
97. The container of claim 95 that comprises a well of a  
microtiter plate.
98. The container of claim 95, that is a vial or test tube.
99. The container of any of claims 95-98, further comprising a  
15 luminescent moiety.
100. A matrix particle, comprising a recording device, wherein:  
the matrix particle is less than about 10 mm<sup>3</sup> in size, and is  
comprised of a polymeric material to which molecules or biological  
molecules can be bound;  
20 the recording device comprises a memory device having a  
memory means for storing a plurality of data points and means for  
receiving the transmitted signal so that the write signal causes a stored  
data point corresponding to the data signal to be stored within the  
memory means;  
25 the recording device is about 20 mm<sup>3</sup> in size or less;  
the recording device is remotely programmable using  
electromagnetic radiation; and  
the recording device is in contact with the particle.



-207-

101. The particle of claim 100, wherein the device is  $10 \text{ mm}^3$  in size or less.

102. The particle of claim 100 or claim 101, further comprising a luminescent moiety.

5           103. In an immunoassay, wherein at least one analyte or the antibody is linked either directly or indirectly to a solid support, the improvement, comprising: combining the solid support matrix with a data storage device containing a programmable memory.

10           104. The immunoassay of claim 103 that is a competitive binding assays or an immunometric assay.

105. The immunoassay of claim 104 that is an enzyme linked immunosorbent assay (ELISA), a radioimmunoassay (RIA), or an enzyme immunoassay (EIA).

15           106. In an assay for detecting or quantitating an analyte or ligand, wherein the analyte or ligand of interest is complexed with a target molecule, and the target molecule or complexes are linked, either directly or indirectly, to a solid support, the improvement, comprising: combining the solid support matrix with a data storage device containing a programmable memory.

20           107. The assay of claim 106 that is a receptor binding assay, a signal transduction assay, a transcription-based assay, or a cell-based assay.

108. The assay of claim 106 or claim 107, wherein the support matrix further comprises a luminescent moiety.

25           109. In a library, comprised of molecules or biological particles, wherein the constituent molecules or biological particles are combined with a solid support matrix, the improvement comprising, combining the solid support matrix with a recording device containing a data storage unit with a programmable memory.

-208-

110. The library of claim 109 that is a combinatorial library.

111. The library of claim 109 or claim 110, wherein the components of the library are molecules that are peptides, peptoids or organic molecules.

5           112. The library of claim 109 or claim 110 that is a phage display library.

113. In an affinity purification protocol, the improvement comprising linking one or more of the affinity resin particles to a recording device containing a data storage unit with a programmable memory.

10           114. An array, comprising a plurality of combinations of any of claims 1-40, wherein:

each combination comprises a recording device that is coated on at least one side with matrix material; and

15           each device is programmed with data identifying the relative position of each combination in the array.

115. The array of claim 114 that is a two-dimensional array.

116. The array of claim 114 that is a three-dimensional array.

117. The array of any of claims 114-116, wherein each combination is contiguous to the adjacent combination, whereby a  
20           continuous matrix surface is formed.

118. The array of any of claims 114-117, wherein the matrix material is nitrocellulose or polyacrylamide.

119. The array of any of claims 114-119, wherein the matrix material comprises a luminescent moiety.

25           120. In a Southern, Northern, Western or dot blot assay, the improvement comprising, linking the blot to a plurality of data storage devices, wherein the relative position in the blot of each data storage device is programmed into its memory.

-209-

121. The assay of claim 120, wherein:  
the blot is comprised of an array containing a plurality of combinations of a matrix with memory;

the combination of a matrix with memory, comprises:

- 5 (A) a recording device, comprising an electromagnetically remotely programmable data storage unit; and  
(B) a matrix material coating at least one side of the device;  
and

the array contains a contiguous arrangement of the combinations,  
10 whereby a continuous blotting surface is formed.

122. The combination of any of claims 1-40, wherein the recording device, further comprises:

reaction detecting means, comprising a sensor means for sensing an energy release or change concentration of an analyte during a reaction  
15 and for generating an electrical signal in response thereto.

123. The combination of claim 122, wherein the reaction detecting means is a photodetector and the energy release comprises an optical emission.

124. The combination of claim 122, wherein the reaction  
20 detecting means is a pH sensor.

125. The combination of claim 122, wherein the reaction detecting means is a temperature sensor and the energy release comprises a change in temperature.

126. The combination of claim 122, wherein the reaction  
25 detecting means is an electromagnetic radiation sensor.

127. The combination of claim 122, wherein the electrical signal forms a data point for storage in the memory means.

128. The combination of any of claims 122-127, further comprising a battery in electrical communication with the memory device  
30 for providing an operating voltage to the memory means.

-210-

129. The method of claim 62, wherein the recording device further comprises means for detecting a reaction and generating an electrical signal in response thereto so that the electrical signal causes a stored data point corresponding to the electrical signal to be stored within  
5 the memory means.

130. The method of claim 66, further comprising generating an electrical signal in response to occurrence of a reaction and storing a data point corresponding to the electrical signal in the memory.

131. The method of claim 77, wherein:  
10 the reaction produces an energy release or change in ion concentration that is detected by the means to detect occurrence of the reaction that comprises sensor means for sensing an energy release or ion concentration change and generating an electrical signal in response thereto, the electrical signal being a data point for storage in the memory  
15 means.

132. The system of Claim 131, wherein the recording device further comprises means for detecting an occurrence of a reaction and generating an electrical signal in response thereto, the electrical signal causing a data point corresponding to the electrical signal to be stored  
20 within the memory means.

133. The system of claim 132, wherein the means for detecting an occurrence of a reaction comprises a photodetector and the energy release comprises an optical emission.

134. The system of claim 132, wherein the means for detecting  
25 an occurrence of a reaction comprises a temperature sensor and the energy release comprises change in temperature

-211-

135. The system of claim 132, wherein the means for detecting an occurrence of a reaction comprises a radiation sensor or a pH sensor.

136. The system of claim 82, further comprising a battery in electrical communication with the memory device for providing an  
5 operating voltage to the memory means.

137. In a method for drug delivery, the improvement, comprising:  
combining the combination of claim 1 with a sensor that detects changes in an internal condition in the body of the animal and causes a record of such change to be recorded in the memory in the combination;  
10 introducing the resulting combination-sensor into the body of an animal to whom drug is delivered; and  
monitoring the body of the animal with a means that reads the memory in the combination.

138. The method of claim 137, wherein the internal conditions is  
15 the concentration of a metabolite, hormone, or electrolyte.

139. The method of claim 137, wherein the internal condition is the concentration of glucose.

140. A multiplexed method, comprising coupling synthesis of compounds with high throughput screening

20 141. The method of claim 140, comprising:  
preparing a library of molecules or biological particles on matrices with memories of any of claims 1-40; and,  
on the same platform, using the resulting library to screen test compounds.

25 142. The method of claim 141, wherein the library is synthesized on the matrix with memory and during synthesis the identity of the molecule or component of the molecule is written to the memory.

-212-

143. A method for simultaneous determination of  $K_a$  values of ligands for a mixture of binding agents, comprising:

linking each of the different binding agents to a combination of claim 1 to produce linked binding agents,

5 incubating the linked binding agents with a non-saturating concentration of labeled ligand to form complexes;

determining the amount of bound ligand and querying the memory in the combination, whereby identity of the binding agent to which ligand is bound is determined;

10 adding additional ligand and repeating the incubating and determining steps and repeating this addition of ligand, incubating and determining until all binding sites on the binding agent approach saturation, whereby  $K_a$  values for each agent are determined and/or number binding sites are determined.

15 144. A method for simultaneous determination of  $K_a$  values of binding agents for a mixture of ligands, comprising:

linking each of the different ligands to a combination of claim 1 to produce linked ligands,

20 incubating the linked ligands with a non-saturating concentration of labeled binding agent to form complexes;

determining the amount of bound agent and querying the memory in the combination, whereby identity of the ligand to which the binding agent is bound is determined;

25 adding additional binding agent and repeating the incubating and determining steps and repeating this addition of ligand, incubating and determining until all binding sites on the binding agent approach saturation, whereby  $K_a$  values for each ligand are determined and/or number binding sites are determined.

-213-

145. A multianalyte method for identifying a receptor binding ligand from among a mixture of compounds, comprising:

- a) labeling the receptor with a radiolabel or a fluophor;
- b) reacting the receptor with a plurality of luminescing matrices with memories of claim 15, wherein each matrix with memory comprises a compound and the identify of the compound is encoded in the memory;
- c) selecting a light emitting luminescing matrix with memory to which receptors have bound; and
- d) querying the memory of the selected matrix with memory to identify the compound.

146. The method of claim 145, wherein the luminescing memories with matrices comprise scintillants and the receptors are labeled with a radiolabel.

147. The method of claim 145, wherein the luminescing memories with matrices comprise donor fluophores and the receptors are labeled with acceptor fluophores.

148. The method of claim 145, wherein the luminescing memories with matrices comprise acceptor fluophores and the receptors are labeled donor fluophores.

149. The method of claim 147, wherein the donor fluophor is a rare earth metal cryptate and the acceptor is selected from among allophycocyanin [APC], allophycocyanin B, phycocyanin C or phycocyanin R, a rhodamine, thiomine, phycoerythrocyanin, phycoerythrin C, phycoerythrin B or phycoerythrin R.

150. The method of claim 148, wherein the donor fluophor is a rare earth metal cryptate and the acceptor is selected from among allophycocyanin [APC], allophycocyanin B, phycocyanin C or phycocyanin R, a rhodamine, thiomine, phycoerythrocyanin, phycoerythrin C, phycoerythrin B or phycoerythrin R.

-214-

151. The method of claim 145, wherein the receptor is selected from the group consisting of antibodies, antigens, deoxyribonucleic acids, ribonucleic acids, cell surface receptors, steroid receptors and ion channels.

5           152. The method of claim 145, wherein the ligand is selected from the group consisting of antibodies, antigens, deoxyribonucleic acids, ribonucleic acids, modulators of receptors or ion channel activities, steroids, enzymes, hormones and vitamins.

10           153. The method of claim 145, wherein the compounds comprise a library of small organic molecules.

154. The combination of claim 1, wherein the matrix material is selected from the group consisting of activated base glass and calcium fluoride.

15           155. The combination of claim 154, wherein the matrix material is activated yttrium silicate.

156. The combination of claim 155, wherein the activated yttrium silicate comprises yttrium silicate and an inorganic salt of one element selected from the group of elements consisting of Mn, Cu, Pb, Sn, Au, Ag, Sm, and Ce.

20           157. The combination of claim 156, wherein the activated yttrium silicate includes from about 0.1 to about 10.0% by weight of an inorganic salt of one of the elements.

158. The combination of claim 1, wherein the matrix is particulate and its largest dimension is from about 1 to about 300 microns.

25           159. The method of claim 76, wherein:  
the reaction produces a photoemission that is detected by  
the means to detect occurrence of the reaction, which comprises a photodetector that is sensitive to the frequencies of the photoemissions from the reaction.



-215-

160. The method of claim 77, wherein:  
the reaction produces a photoemission that is detected by  
the means to detect occurrence of the reaction, which comprises a  
photodetector that is sensitive to the frequencies of the photoemissions  
5 from the reaction.

161. In a scintillation proximity assay, the improvement  
comprising including a recording device in contact with the matrix  
material that contains scintillant.

162. In a scintillation proximity assay, the improvement  
10 comprising:  
adding a radiolabel to the matrix material in a combination of any  
of claims 1-40;  
coating the matrix with a receptor and entering the identity of the  
receptor in the recording device memory;  
15 linking a ligand to a second matrix that contains scintillant;  
reacting the ligand with labeled matrix, whereby light is produced.

163. In a scintillation proximity assay, the improvement  
comprising:  
adding a radiolabel to the matrix material in a combination of any  
20 of claims 1-40;  
coating the matrix with a ligand and entering the identity of the  
ligand in the recording device memory;  
linking a receptor to a second matrix particle that contains  
scintillant;  
25 reacting the receptor with the labeled matrix, whereby light is  
produced.

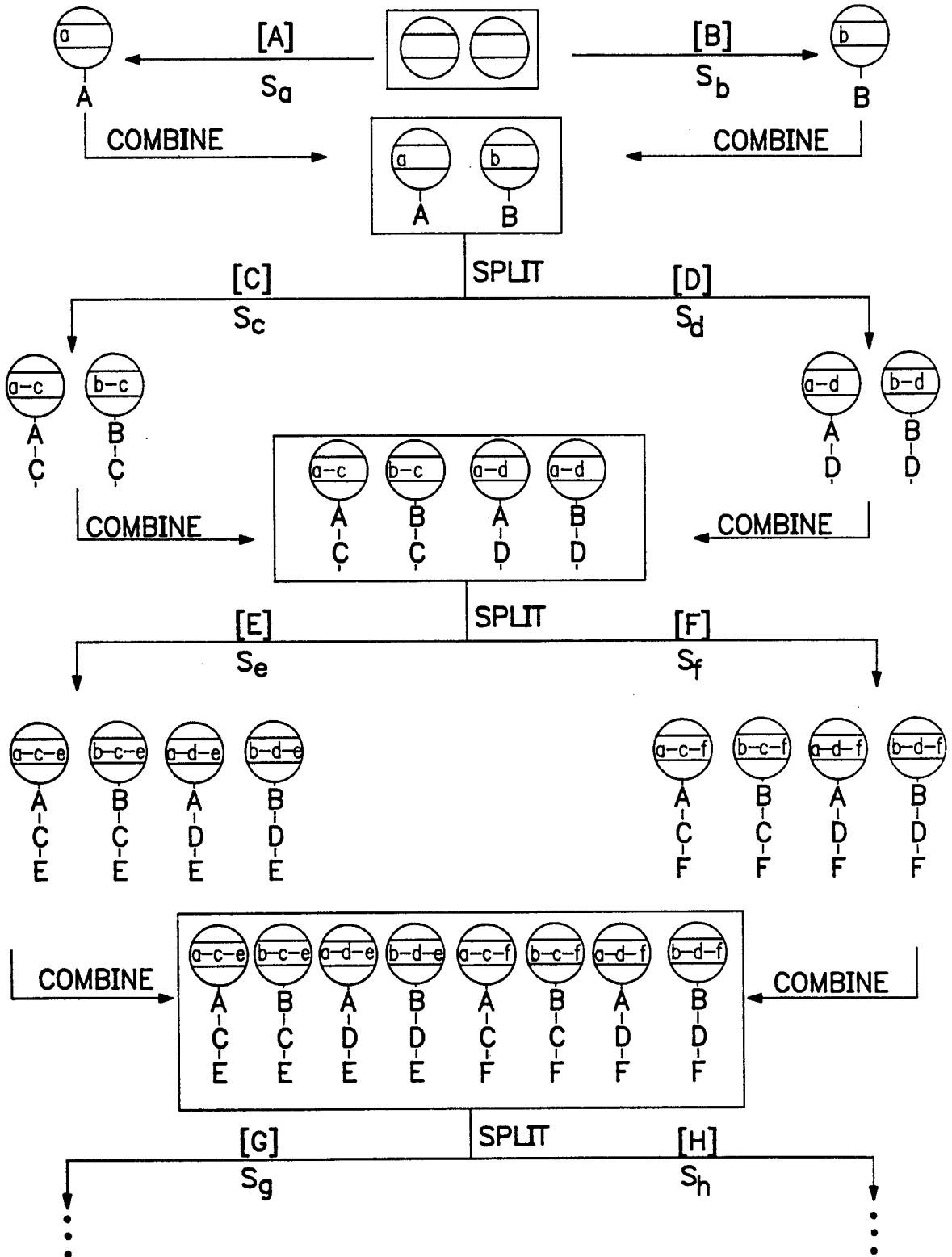

FIG. 1

SUBSTITUTE SHEET (RULE 26)

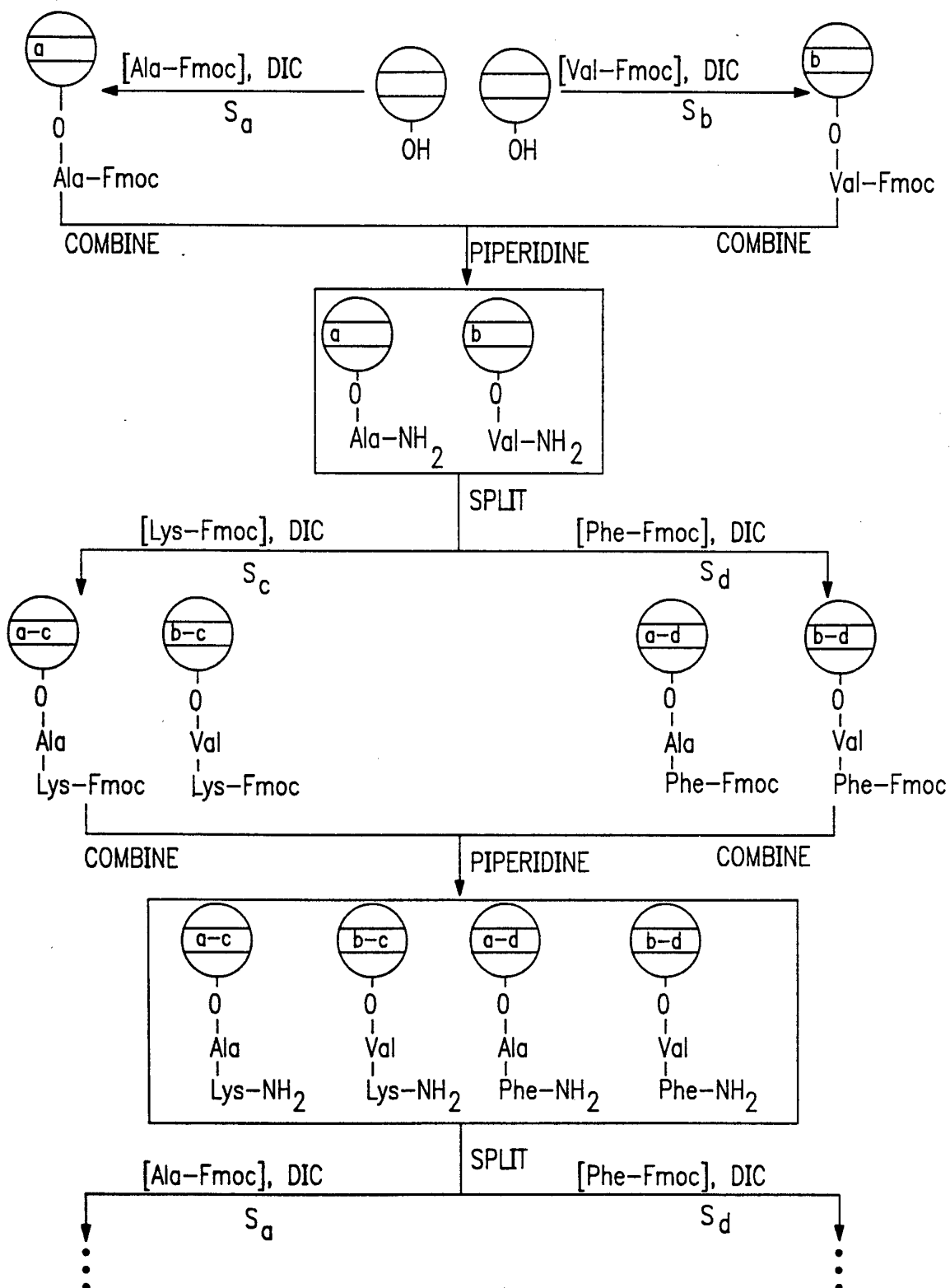

FIG. 2

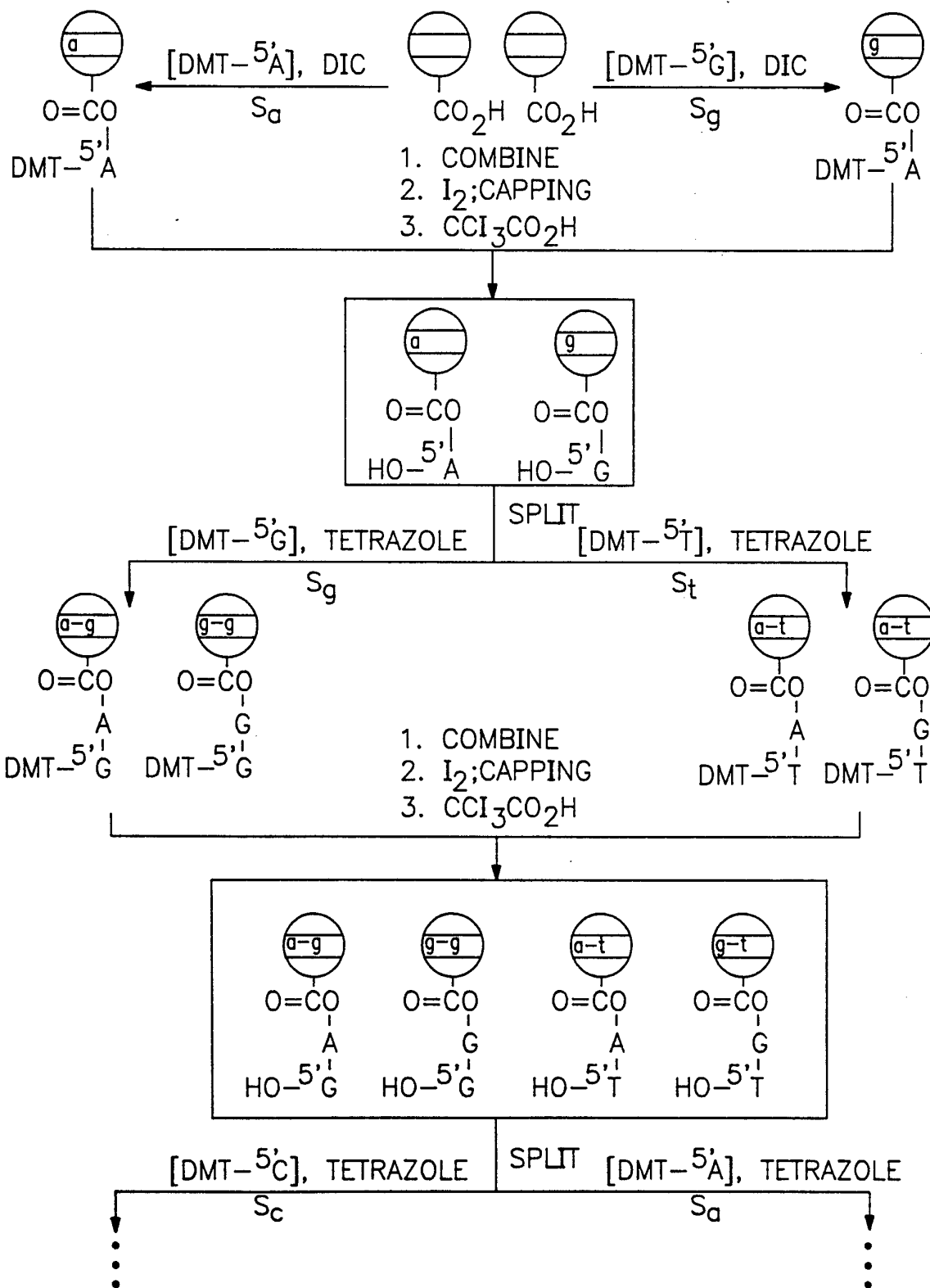

FIG. 3

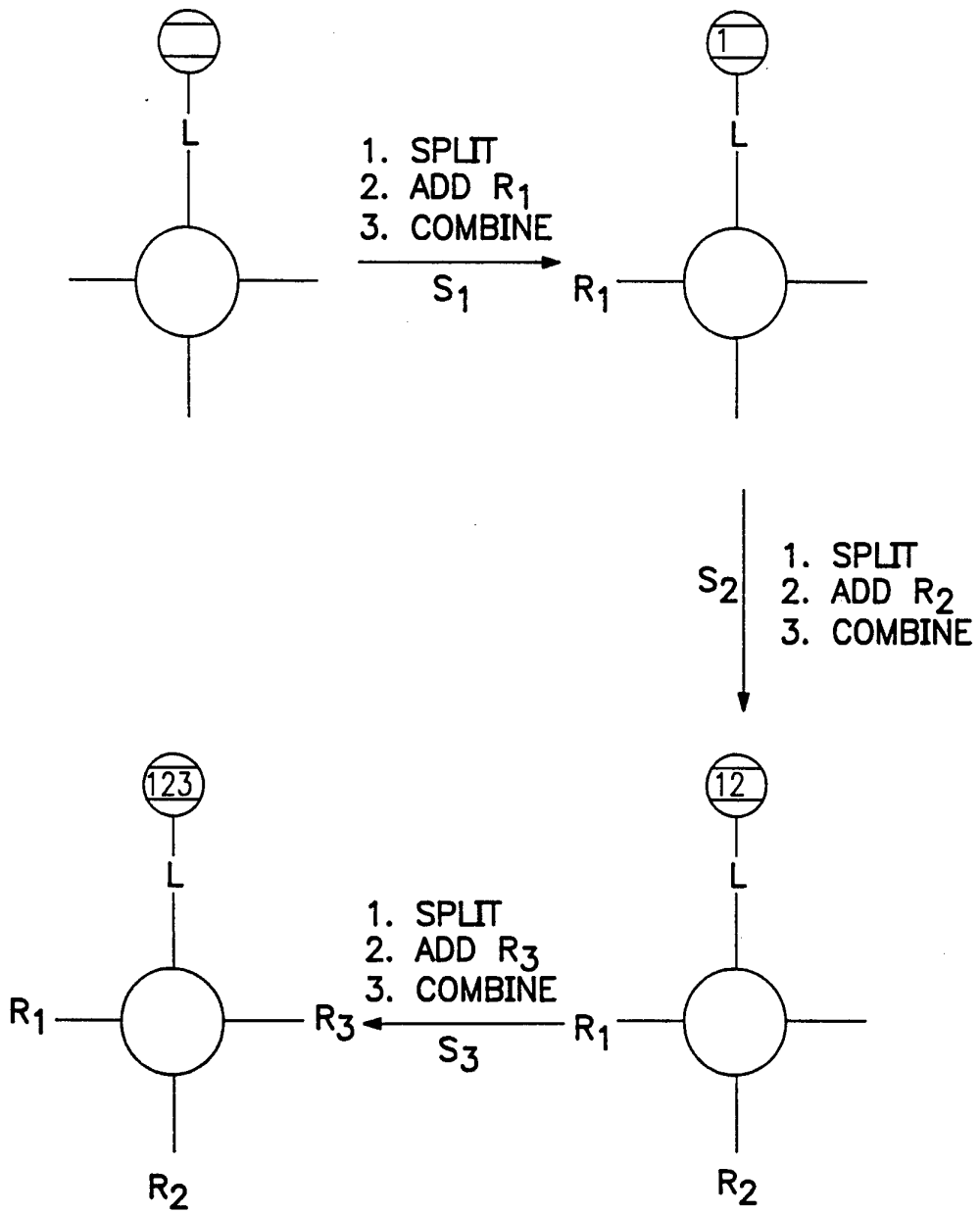

FIG. 4

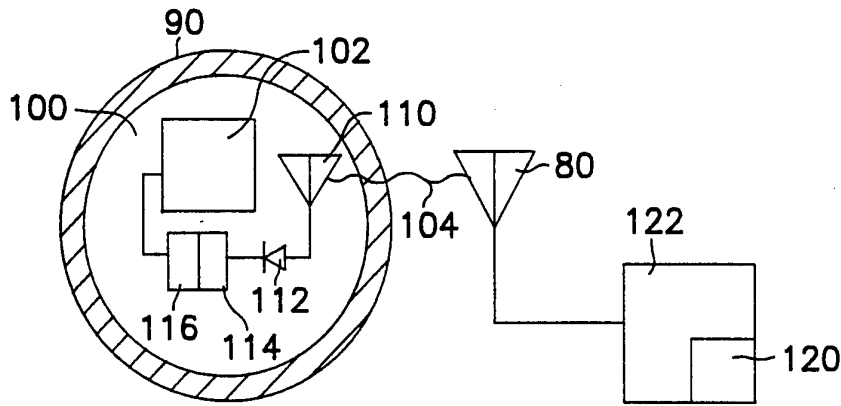

FIG. 5

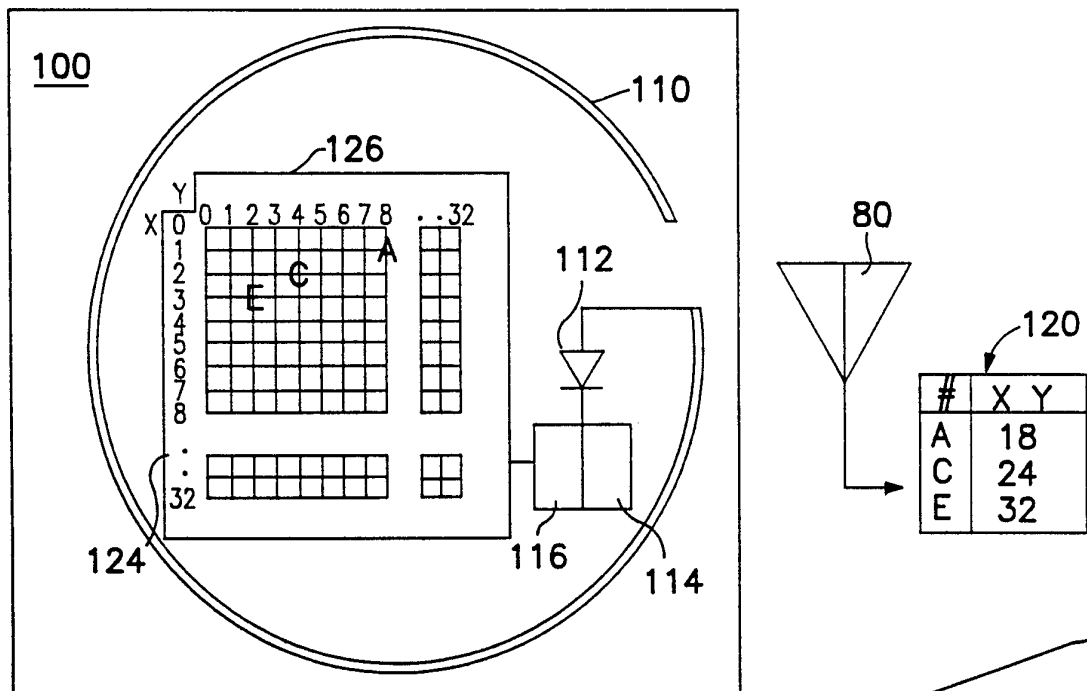

FIG. 6

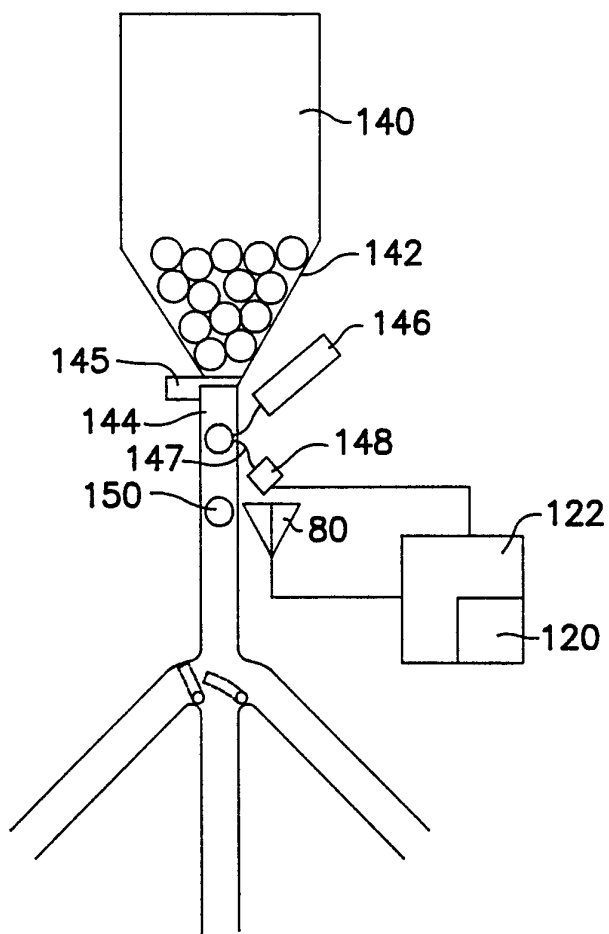

FIG. 7

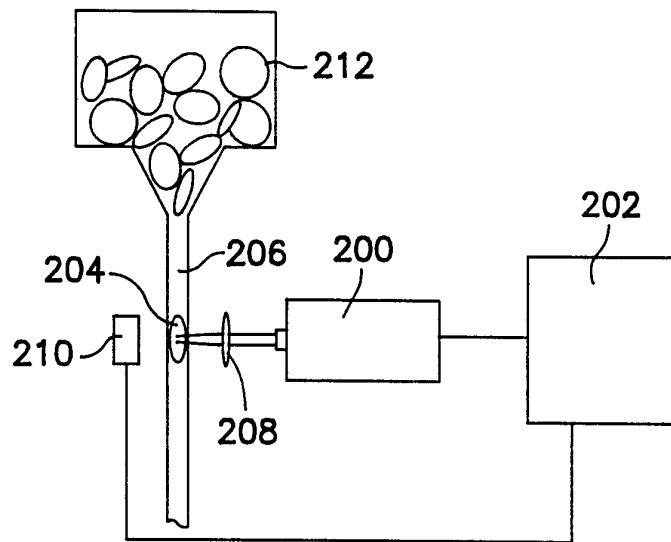

FIG. 8



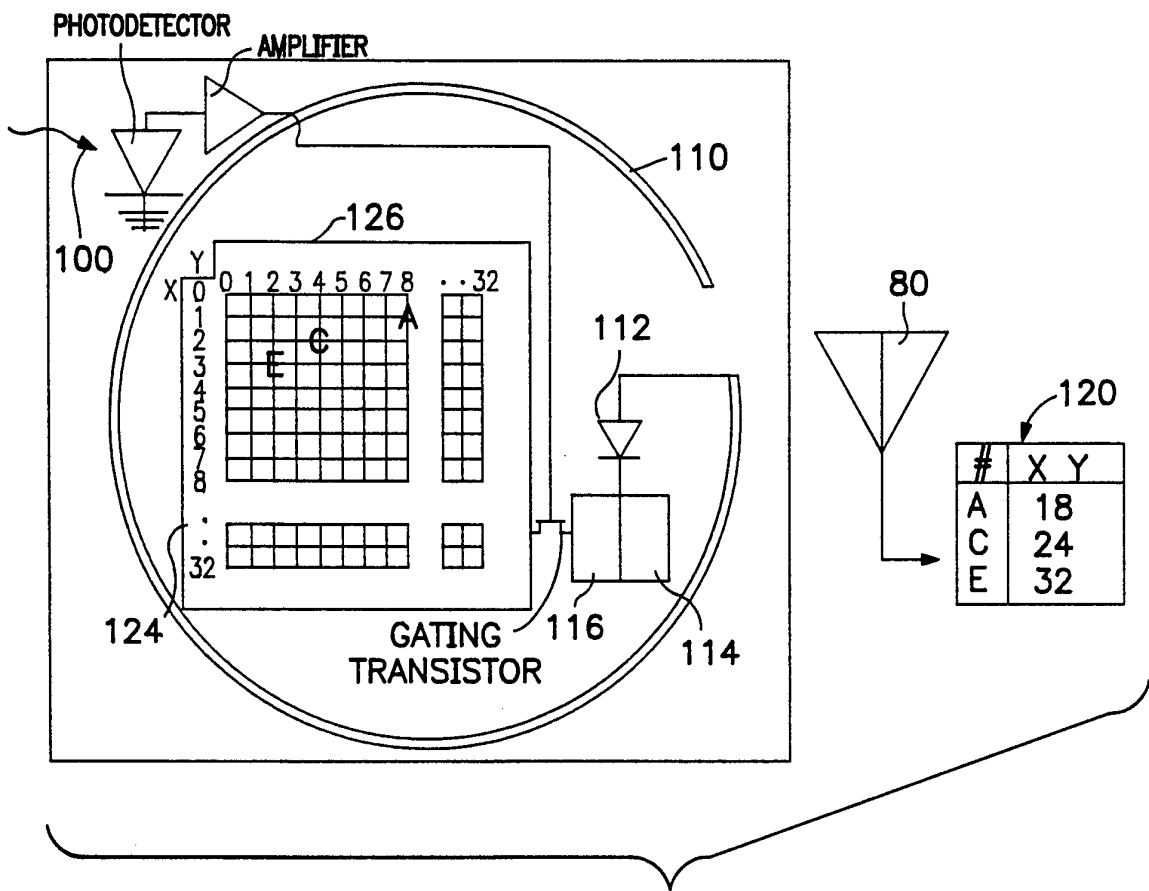

FIG. 9

9 / 16

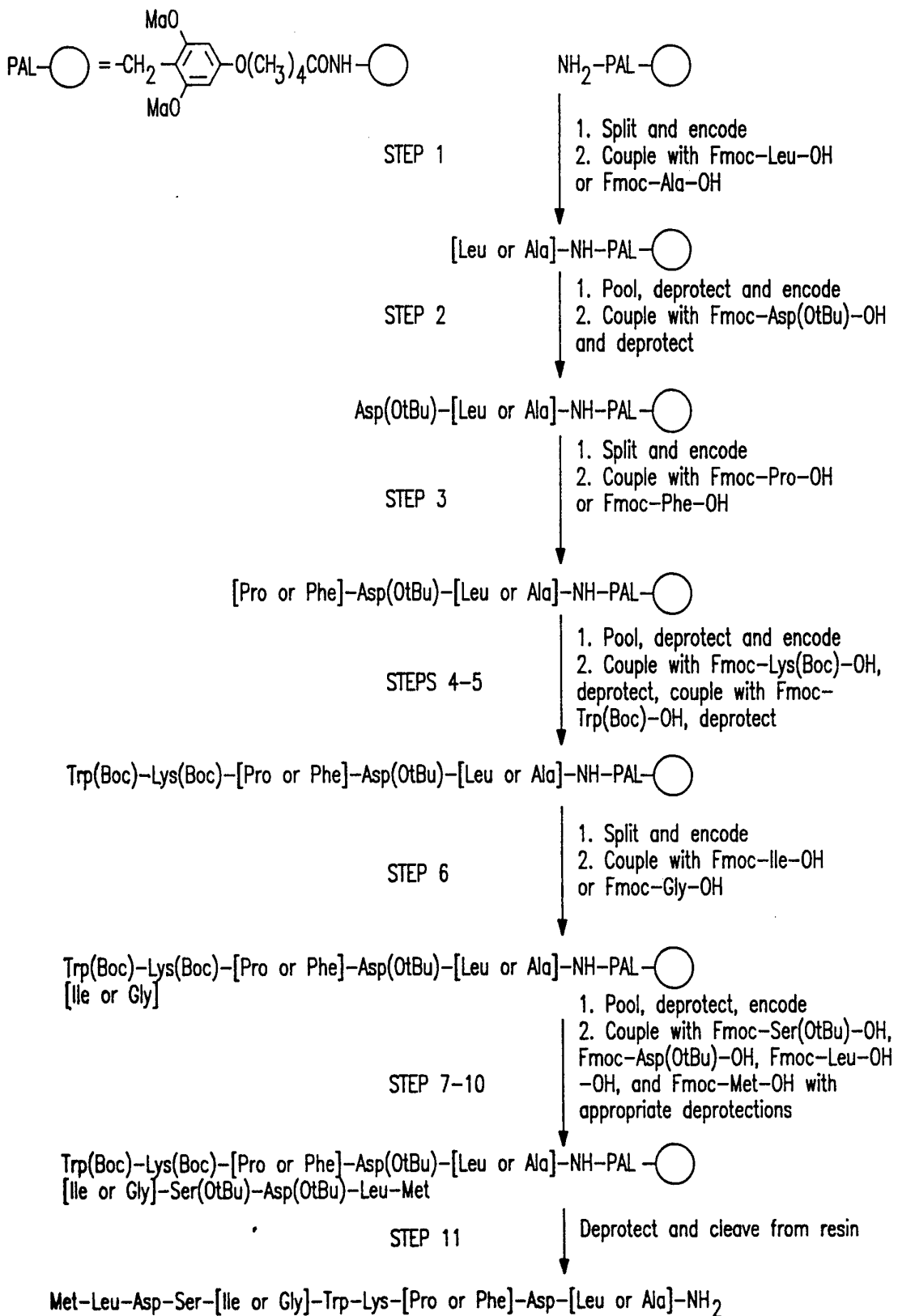

FIG. 10

SUBSTITUTE SHEET (RULE 26)

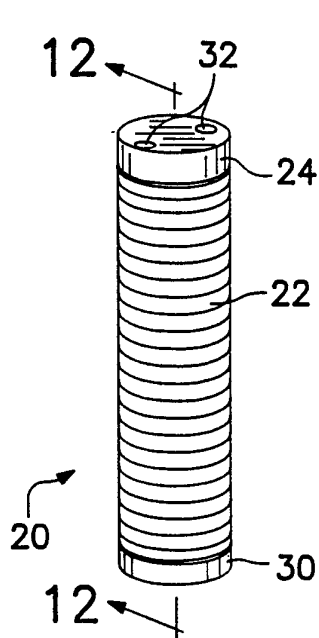

FIG. 11

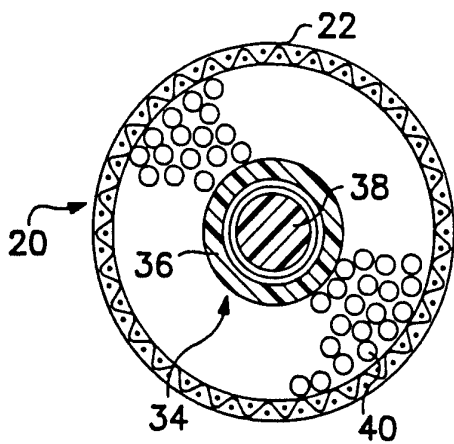

FIG. 13

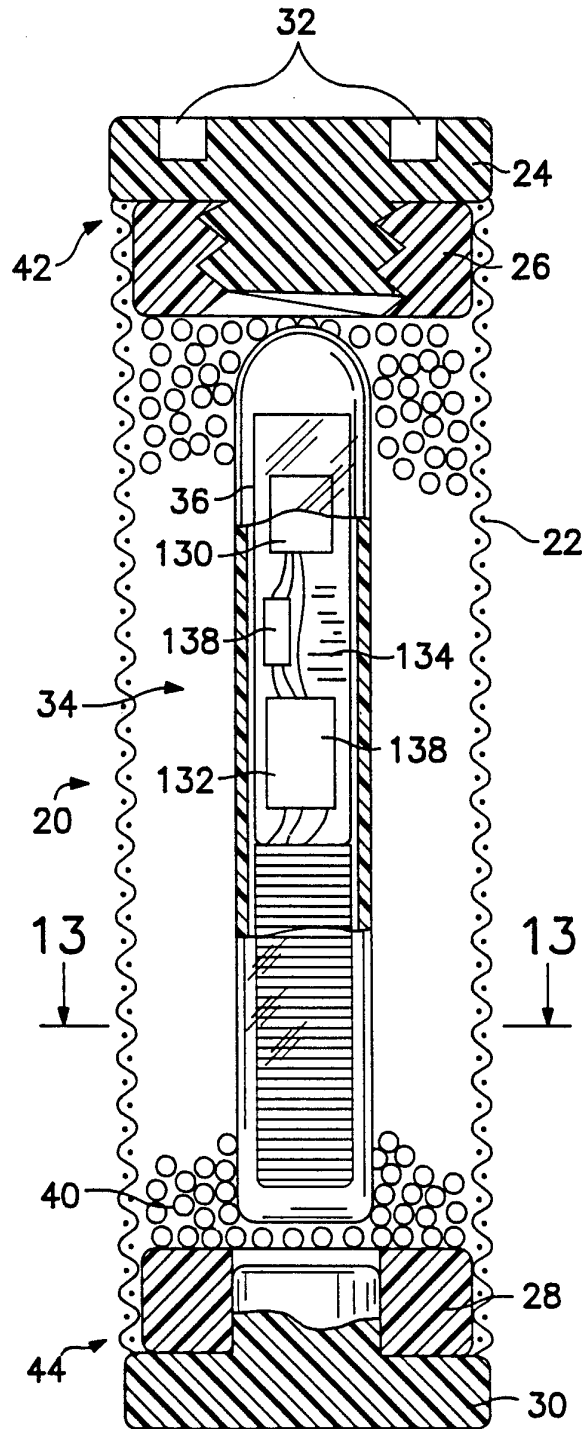

FIG. 12

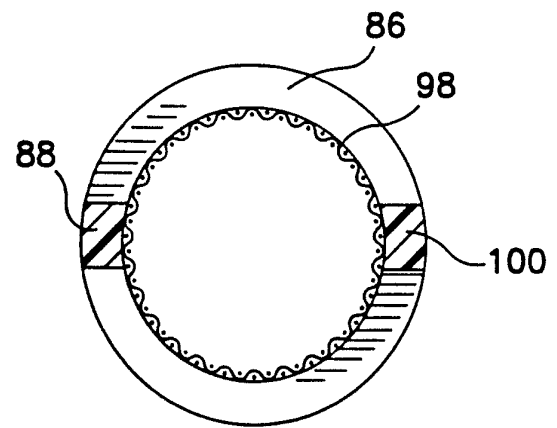
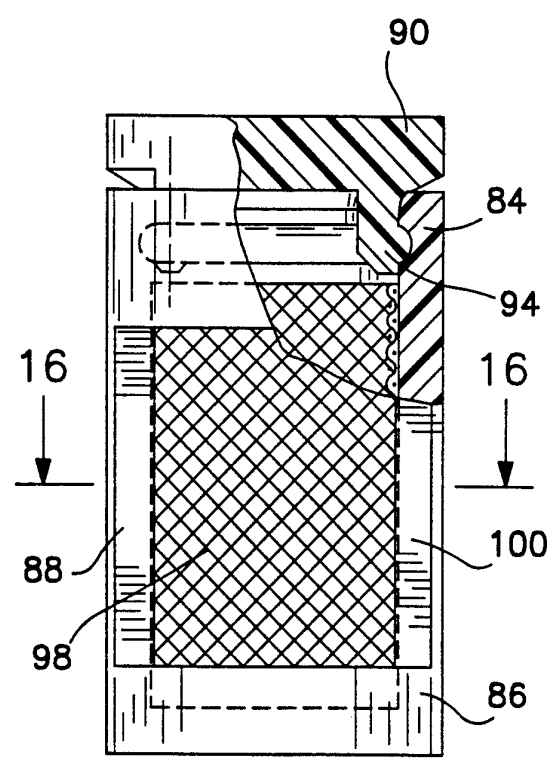
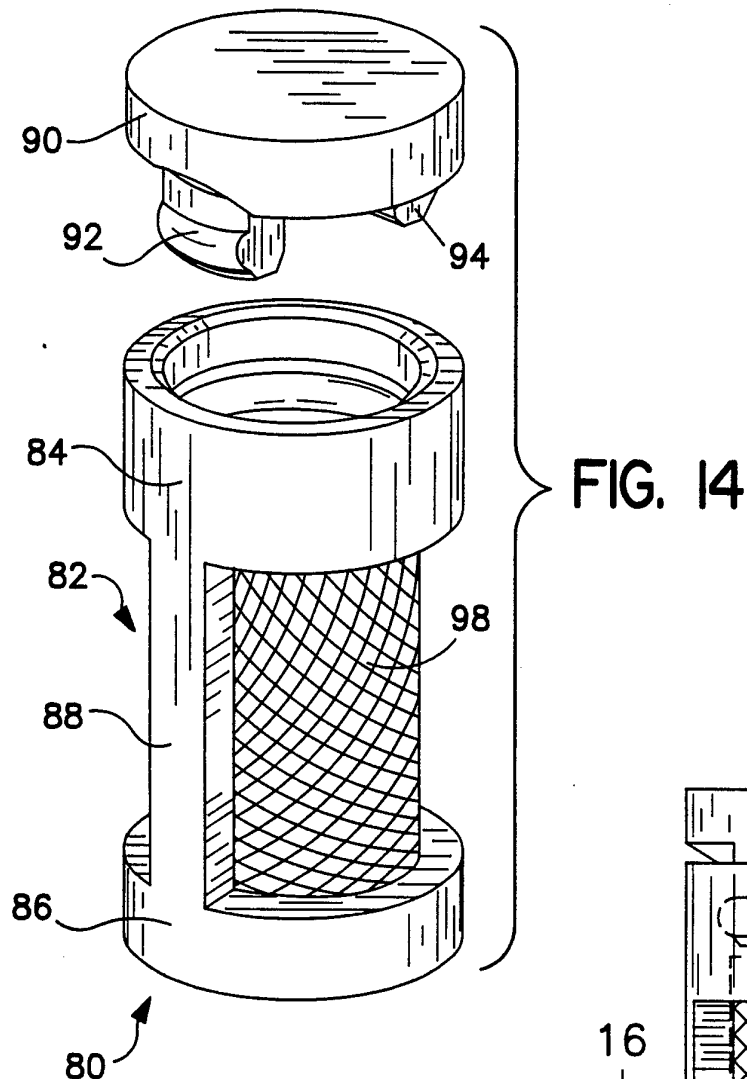

FIG. 16

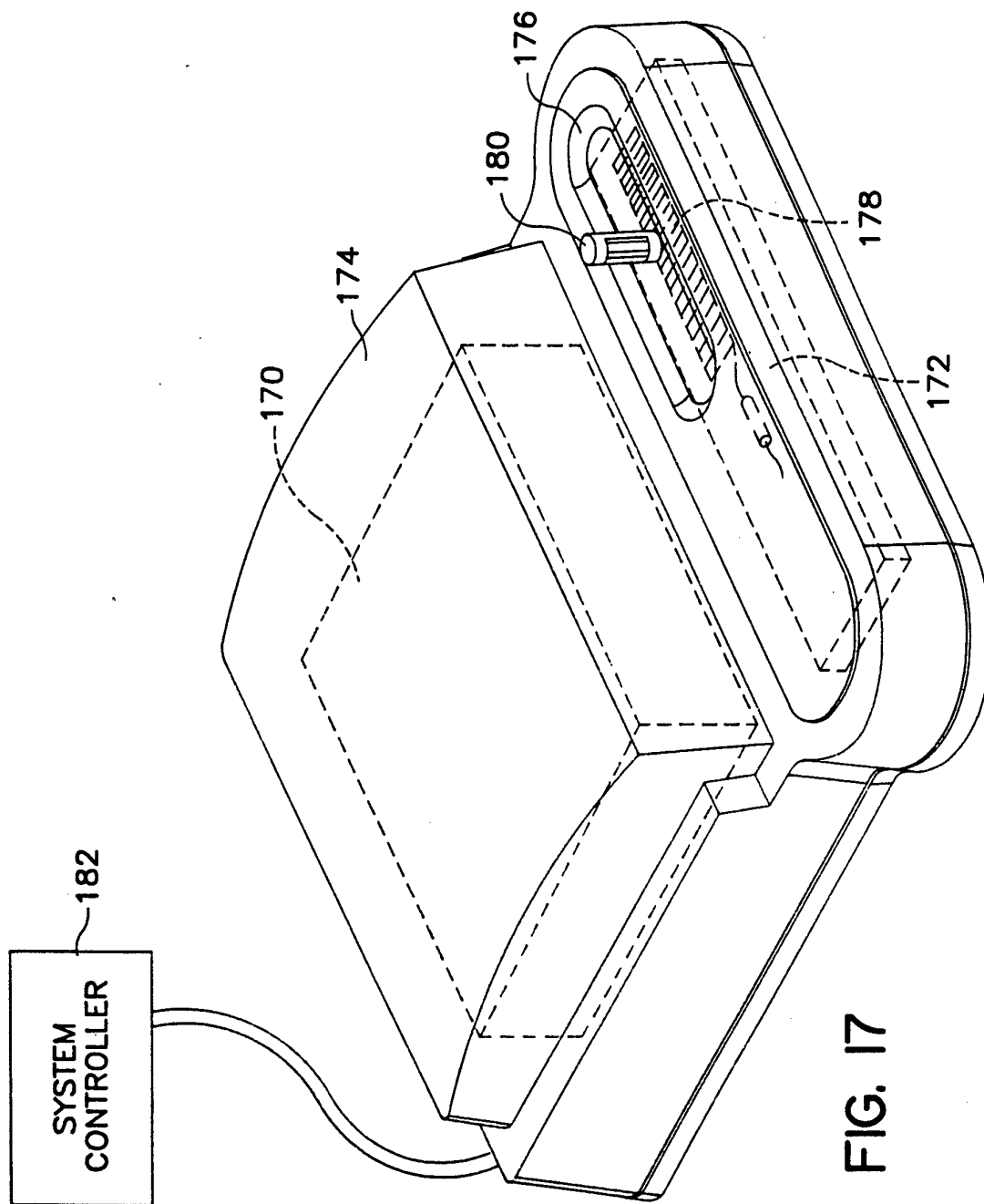

FIG. 17

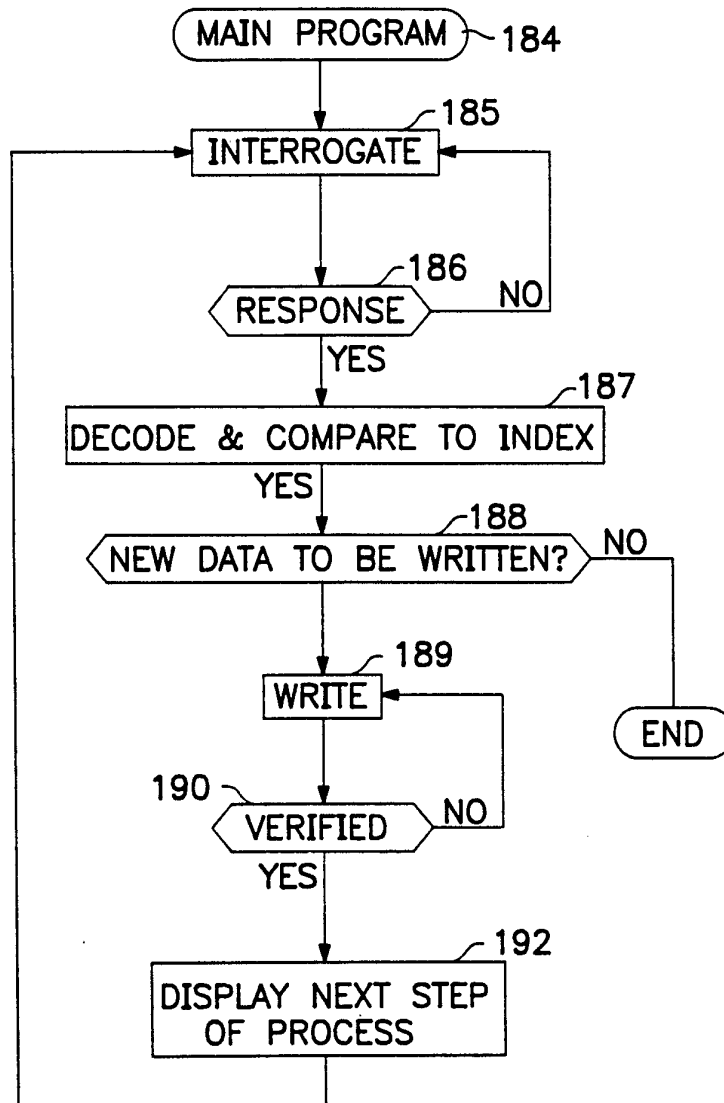

FIG. 18

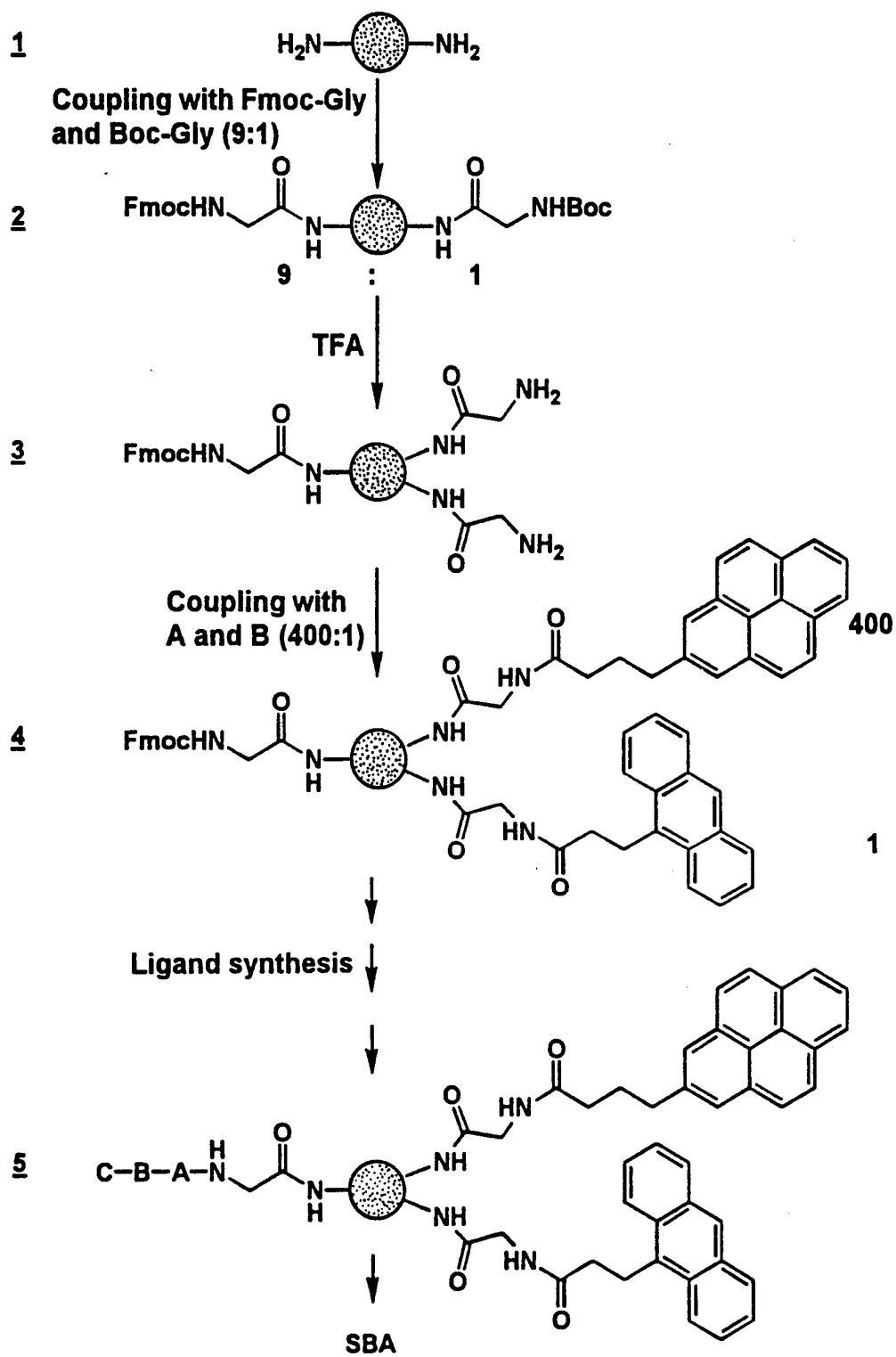

FIG. 19

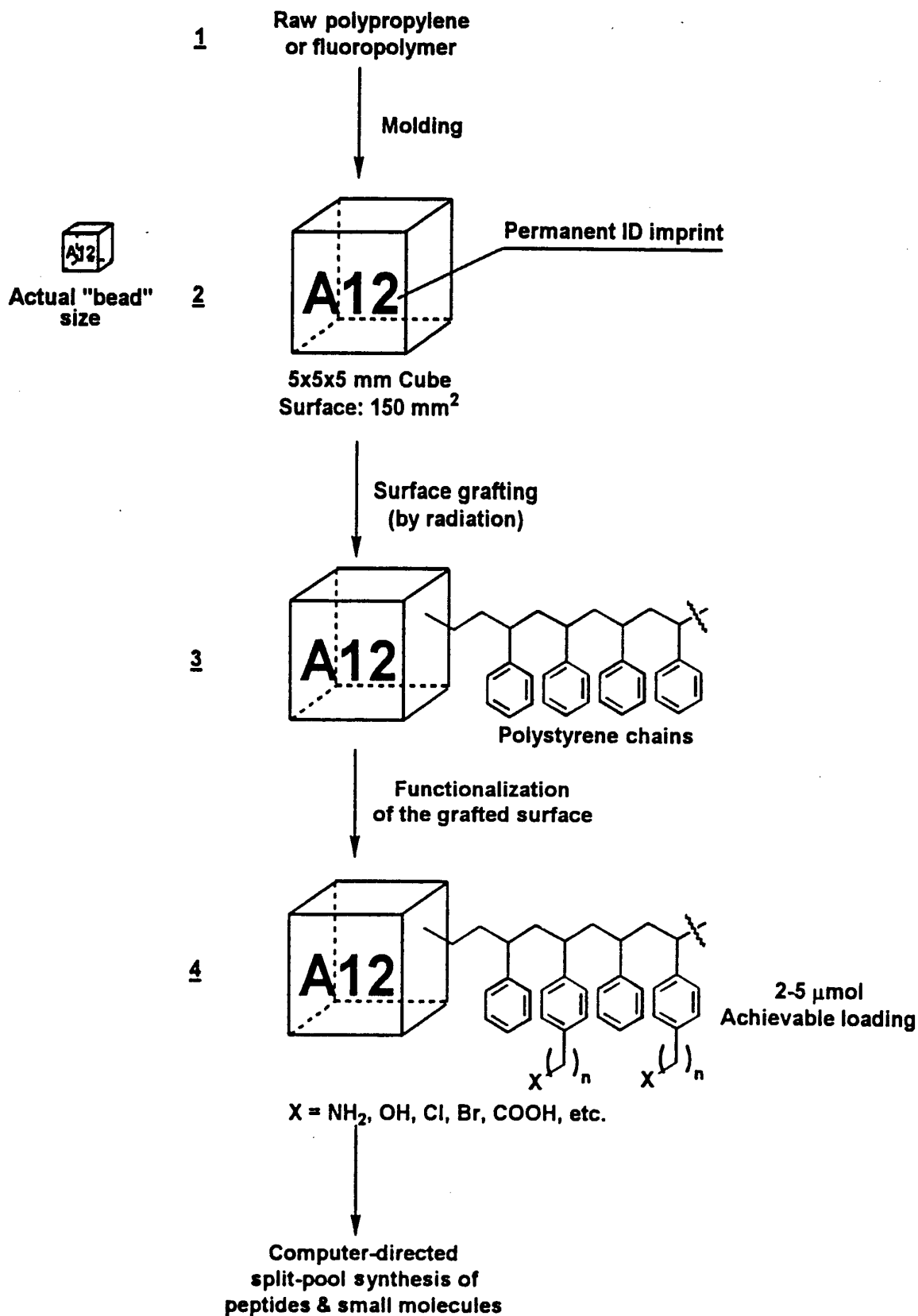

FIG. 20  
SUBSTITUTE SHEET (RULE 26)



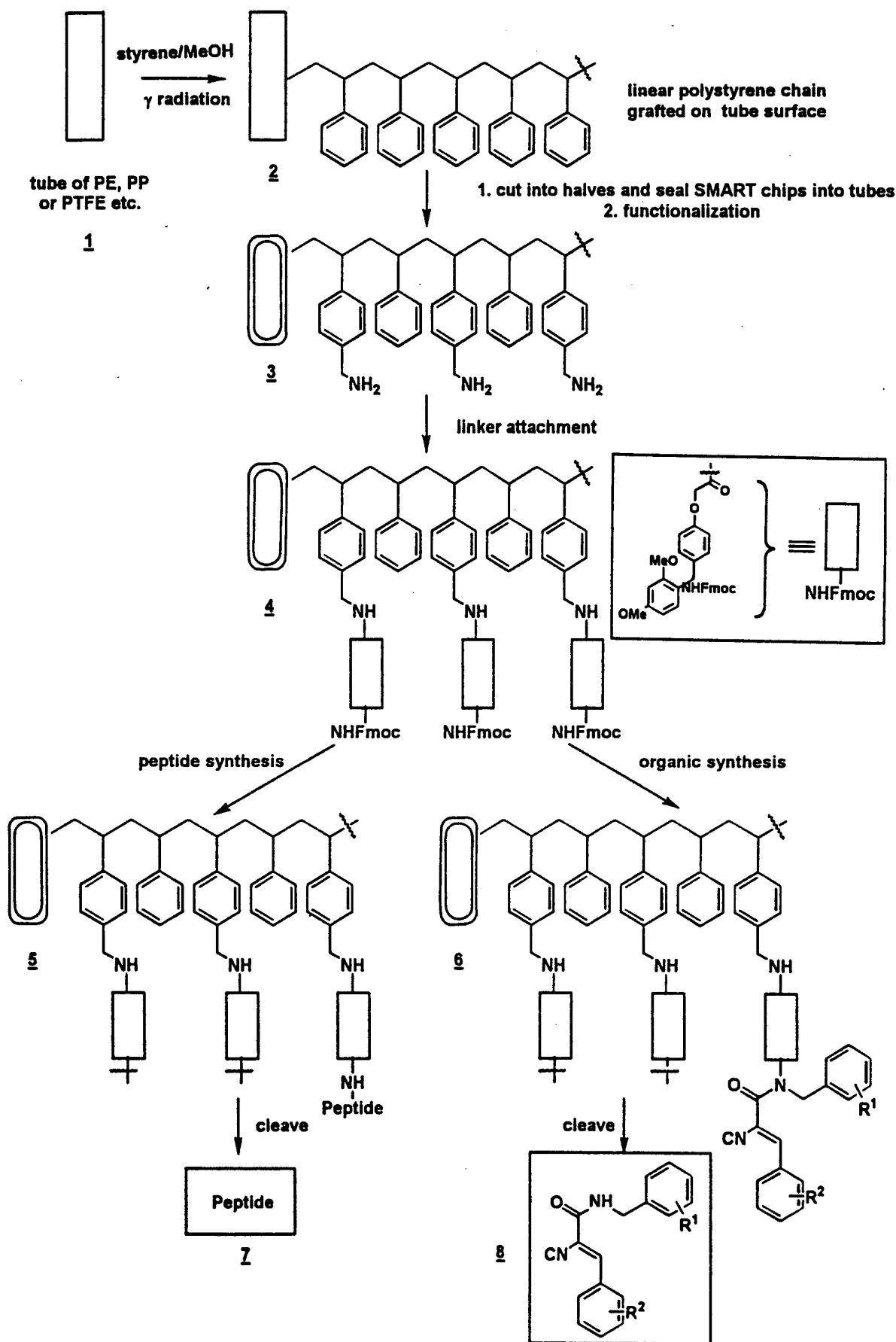

FIG. 21

# INTERNATIONAL SEARCH REPORT

International Application No  
PCT/US 96/06145

**A. CLASSIFICATION OF SUBJECT MATTER**  
 IPC 6 B01L3/14 G01N35/00 C07K1/04 G01N33/48 G01N33/58  
 G01N33/543 B01J19/00

According to International Patent Classification (IPC) or to both national classification and IPC

**B. FIELDS SEARCHED**  
 Minimum documentation searched (classification system followed by classification symbols)  
 IPC 6 B01J G01N B01L C07K

Documentation searched other than minimum documentation to the extent that such documents are included in the fields searched

Electronic data base consulted during the international search (name of data base and, where practical, search terms used)

**C. DOCUMENTS CONSIDERED TO BE RELEVANT**

| Category* | Citation of document, with indication, where appropriate, of the relevant passages | Relevant to claim No. |
|-----------|--|-----------------------|
|           | -/--   |                       |

Further documents are listed in the continuation of box C.       Patent family members are listed in annex.

\* Special categories of cited documents :

|  |  |
|--|--|
| <p>*A* document defining the general state of the art which is not considered to be of particular relevance</p> <p>*E* earlier document but published on or after the international filing date</p> <p>*L* document which may throw doubts on priority claim(s) or which is cited to establish the publication date of another citation or other special reason (as specified)</p> <p>*O* document referring to an oral disclosure, use, exhibition or other means</p> <p>*P* document published prior to the international filing date but later than the priority date claimed</p> | <p>*T* later document published after the international filing date or priority date and not in conflict with the application but cited to understand the principle or theory underlying the invention</p> <p>*X* document of particular relevance; the claimed invention cannot be considered novel or cannot be considered to involve an inventive step when the document is taken alone</p> <p>*Y* document of particular relevance; the claimed invention cannot be considered to involve an inventive step when the document is combined with one or more other such documents, such combination being obvious to a person skilled in the art.</p> <p>*Z* document member of the same patent family</p> |
|--|--|

|   |  |
|---|--|
| Date of the actual completion of the international search | Date of mailing of the international search report |
| 13 September 1996   | 20.09.96   |

|   |   |
|---|---|
| Name and mailing address of the ISA<br>European Patent Office, P.B. 5818 Patentlaan 2<br>NL - 2280 HV Rijswijk<br>Tel. (+ 31-70) 340-2040, Tx. 31 651 epo nl.<br>Fax (+ 31-70) 340-3016 | Authorized officer<br><br>Stevnsborg, N |
|---|---|

INTERNATIONAL SEARCH REPORT

International Application No  
PCT/US 96/06145

| C.(Continuation) DOCUMENTS CONSIDERED TO BE RELEVANT |   |  |
|--|---|--|
| Category*  | Citation of document, with indication, where appropriate, of the relevant passages  | Relevant to claim No.  |
| X  | EP,A,0 637 750 (BOEHRINGER MANNHEIM GMBH)<br>8 February 1995  | 2,4,6,<br>10,<br>20-24,<br>28,33,<br>34,36,<br>39,40,<br>58-63,<br>74,75,<br>80,<br>84-86,<br>88,89,<br>122,123<br>127-129                     |
| X<br>A   | see the whole document  | 1,7-9,<br>15,16,<br>26,<br>29-32,<br>38,57,<br>66,<br>81-83,<br>91,92,<br>95,98,<br>100,101,<br>126,<br>130-133<br>136-138,<br>154,159,<br>160 |
| A  |   |  |
| X  | ---<br>US,A,4 857 893 (BI INC.) 15 August 1989  | 58,<br>61-63,<br>74,75,80  |
| A  | see abstract<br>see column 2, line 13 - line 32<br>see column 3, line 21 - line 36<br>see column 9, line 31 - column 10, line 51<br>see column 11, line 11 - line 27<br>see column 11, line 44 - line 65<br>see claims; figures 9A,9B | 1,2,4,8,<br>9,15,16,<br>20,<br>22-24,<br>28,32,<br>57,59,<br>60,66,<br>81,82,<br>84,86,<br>91,95,<br>100,101<br>128,136                        |
| A  | ---<br>-/--   |  |

2

INTERNATIONAL SEARCH REPORT

International Application No  
PCT/US 96/06145

| C.(Continuation) DOCUMENTS CONSIDERED TO BE RELEVANT |  |  |
|--|--|--|
| Category *   | Citation of document, with indication, where appropriate, of the relevant passages | Relevant to claim No.  |
| X  | DE,A,43 06 563 (J. LICHTENBERG ET AL.) 8<br>September 1994                         | 58,<br>60-63,<br>74,75   |
| A  | see the whole document   | 1,2,4,6,<br>8-10,15,<br>16,<br>20-23,<br>28,<br>32-34,<br>36,39,<br>40,57,<br>59,66,<br>77,<br>79-87,<br>91,95,98<br>106,<br>122-128,<br>130-136,<br>160 |
| A  |  |  |
| X  | WO,A,89 08264 (U.W.BALLIES) 8 September<br>1989                                    | 58,<br>60-63,<br>74,75,<br>80,84,86  |
| A  | see the whole document   | 1,2,4,<br>8-10,15,<br>16,20,<br>22-24,<br>28-30,<br>32-34,<br>36,<br>38-40,<br>57,59,<br>66,81,<br>82,85,<br>91,95<br>97,145                             |
| A  |  |  |
|  | ---  |  |
|  |  | -/--   |

INTERNATIONAL SEARCH REPORT

International Application No  
PCT/US 96/06145

| C.(Continuation) DOCUMENTS CONSIDERED TO BE RELEVANT |   |  |
|--|---|--|
| Category   | Citation of document, with indication, where appropriate, of the relevant passages            | Relevant to claim No.  |
| X  | FR,A,2 555 744 (SA PHILIPS INDUSTRIELLE ET COMMERCIALE) 31 May 1985<br>see the whole document | 58,61-63   |
| A  |   | 1,2,4,<br>8-10,15,<br>16,20,<br>22,23,<br>25-30,<br>32-34,<br>36,<br>38-40,<br>57,59,<br>60,<br>64-67,<br>71,74,75     |
| A  |   | 80-82,<br>84-88,<br>91-93,<br>95,98,<br>154  |
| X  | DE,U,94 16 270 (R. GRIEB) 8 December 1994<br>see the whole document                           | 58,74,<br>75,80,86   |
| A  |   | 1,2,4,<br>8-10,15,<br>16,20,<br>22-24,<br>28,<br>32-34,<br>36,<br>38-40,<br>57,<br>59-63,<br>66,81,<br>82,84,<br>85,88 |
| A  |   | 91,95,<br>98,106   |
|  | ---   |  |
|  | -/--  |  |

INTERNATIONAL SEARCH REPORT

International Application No

PCT/US 96/06145

| C.(Continuation) DOCUMENTS CONSIDERED TO BE RELEVANT |   |   |
|--|---|---|
| Category *   | Citation of document, with indication, where appropriate, of the relevant passages  | Relevant to claim No.   |
| X  | ELEKTRONIK,<br>no. 9, 1993, MUNCHEN DE,<br>pages 86-92, XP000362956<br>R. JURISCH: "Identifikation: kontaktlos<br>via Hochfrequenz"<br>see the whole document | 61-63   |
| A  |   | 1,2,4,8,<br>9,15,16,<br>20,<br>22-24,<br>33,34,<br>36,40,<br>80-82,<br>84-88,<br>91,95,<br>100,101,<br>121,128<br>136   |
| A  | ---   |   |
| X  | WO,A,94 05394 (ARRIS PHARMACEUTICAL<br>CORPORATION) 17 March 1994<br>see abstract   | 146   |
| A  |   | 141,142   |
| A  | ---   |   |
| A  | FR,A,2 526 169 (MOCHIDA PHARMACEUTICAL<br>CO., LTD.) 4 November 1983  | 1-3,5-7,<br>10,17,<br>19,21,<br>28,29,<br>31-35,<br>37,<br>39-43,<br>45,56,<br>57,61,<br>66,67,<br>73,76,<br>78,85<br>94,95,<br>97-99,<br>103-106,<br>108,109,<br>111,<br>143-145,<br>147-152 |
| A  |   |   |
| A  | see the whole document<br>---   |   |
| A  | DE,A,43 10 169 (OLYMPUS OPTICAL CO., LTD.)<br>30 September 1993   | 1-3,6,9,<br>10,21,<br>28,29,<br>32,40,<br>57,58,<br>60,96,<br>97,103,<br>106,107  |
|  | see the whole document<br>---   |   |
|  | ---   |   |
|  | -/--  |   |

## INTERNATIONAL SEARCH REPORT

 International Application No  
 PCT/US 96/06145

## C.(Continuation) DOCUMENTS CONSIDERED TO BE RELEVANT

| Category | Citation of document, with indication, where appropriate, of the relevant passages  | Relevant to claim No.  |
|----------|---|--|
| A        | EP,A,0 541 340 (APPLIED BIOSYSTEMS, INC.)<br>12 May 1993<br><br>see abstract<br>see column 3, line 18 - line 26<br>see column 3, line 39 - line 50<br>see column 5, line 25 - line 37<br>see column 8, line 37 - line 50<br>---     | 3,10,17,<br>18,28,<br>32,<br>39-41,<br>52,53,<br>68-71,<br>95,96,98      |
| A        | EP,A,0 196 174 (SCRIPPS CLINIC AND<br>RESEARCH FOUNDATION) 1 October 1986<br><br>see abstract<br>see page 15, line 30 - line 35<br>see page 16, line 28 - page 17, line 5<br>see figures 1,3<br>---                                 | 1,3,5,7,<br>10,17,<br>18,31,<br>37,<br>39-41,<br>67-71,<br>100,111       |
| A        | WO,A,94 26413 (AMERSHAM INTERNATIONAL PLC)<br>24 November 1994<br>cited in the application<br><br>see abstract<br>see page 11, line 3 - page 12, line 25<br>see page 17, line 17 - page 18, last line<br>see claims; figures<br>--- | 29,<br>42-47,<br>50,<br>52-54,<br>56,<br>145-152,<br>154,156,<br>161-163 |
| A        | US,A,5 288 291 (DATAPET, INC.) 22 February<br>1994<br>see abstract<br>see column 1, paragraph 2 - paragraph 3<br>see column 2, paragraph 1<br>---   | 137  |
| A        | EP,A,0 420 177 (ARGUMENS GMBH) 3 April<br>1991<br>see abstract<br>see column 1, line 1 - column 2, line 18<br>---   | 137  |
| A        | DE,A,42 13 065 (N.H.L.KOSTER) 28 October<br>1993<br>see abstract<br>see column 4, line 30 - line 56<br>---<br>-/--  | 137  |

2

INTERNATIONAL SEARCH REPORT

In ternational Application No  
PCT/US 96/06145

C.(Continuation) DOCUMENTS CONSIDERED TO BE RELEVANT

| Category | Citation of document, with indication, where appropriate, of the relevant passages                       | Relevant to claim No. |
|----------|--|-----------------------|
| A        | US,A,5 384 028 (NEC CORPORATION) 24<br>January 1995<br>cited in the application<br>see abstract<br>----- | 138,139               |

2



## INTERNATIONAL SEARCH REPORT

Information on patent family members

International Application No

PCT/US 96/06145

| Patent document cited in search report | Publication date | Patent family member(s)   | Publication date   |
|--|------------------|---|--|
| EP-A-0637750                           | 08-02-95         | DE-A- 4326342<br>JP-A- 7151766  | 09-02-95<br>16-06-95   |
| US-A-4857893                           | 15-08-89         | US-A- 4724427<br>AU-B- 591420<br>AU-A- 7751287<br>CA-A- 1285049<br>DE-D- 3788513<br>DE-T- 3788513<br>EP-A- 0274526<br>WO-A- 8800785 | 09-02-88<br>30-11-89<br>10-02-88<br>18-06-91<br>27-01-94<br>07-04-94<br>20-07-88<br>28-01-88 |
| DE-A-4306563                           | 08-09-94         | NONE  |  |
| WO-A-8908264                           | 08-09-89         | NONE  |  |
| FR-A-2555744                           | 31-05-85         | NONE  |  |
| DE-U-9416270                           | 08-12-94         | EP-A- 0706825<br>JP-A- 8211065  | 17-04-96<br>20-08-96   |
| WO-A-9405394                           | 17-03-94         | AU-A- 4844593<br>AU-A- 6393994<br>JP-T- 8507602<br>WO-A- 9419694  | 29-03-94<br>14-09-94<br>13-08-96<br>01-09-94   |
| FR-A-2526169                           | 04-11-83         | JP-A- 58189558<br>DE-A- 3314993<br>GB-A,B 2129551<br>NL-A- 8301490<br>SE-A- 8302377   | 05-11-83<br>03-11-83<br>16-05-84<br>16-11-83<br>29-10-83                                     |
| DE-A-4310169                           | 30-09-93         | JP-A- 5273216   | 22-10-93   |
| EP-A-0541340                           | 12-05-93         | US-A- 5298259<br>JP-A- 5255384<br>US-A- 5462748   | 29-03-94<br>05-10-93<br>31-10-95   |
| EP-A-0196174                           | 01-10-86         | US-A- 4631211<br>AU-B- 594327   | 23-12-86<br>08-03-90   |

## INTERNATIONAL SEARCH REPORT

information on patent family members

International Application No

PCT/US 96/06145

| Patent document cited in search report | Publication date | Patent family member(s)  | Publication date   |
|--|------------------|--|--|
| EP-A-0196174                           |                  | AU-A- 5490486<br>CA-A- 1242701<br>JP-A- 61275296   | 02-10-86<br>04-10-88<br>05-12-86                                     |
| WO-A-9426413                           | 24-11-94         | CA-A- 2139409<br>DE-T- 650396<br>EP-A- 0650396<br>ES-T- 2072847<br>FI-A- 950154<br>JP-T- 7509405 | 24-11-94<br>30-11-95<br>03-05-95<br>01-08-95<br>13-01-95<br>19-10-95 |
| US-A-5288291                           | 22-02-94         | AU-A- 4799893<br>EP-A- 0655007<br>WO-A- 9404217  | 15-03-94<br>31-05-95<br>03-03-94                                     |
| EP-A-0420177                           | 03-04-91         | DE-A- 3932428<br>AT-T- 117188<br>DE-D- 59008294<br>ES-T- 2066926                                 | 11-04-91<br>15-02-95<br>02-03-95<br>16-03-95                         |
| DE-A-4213065                           | 28-10-93         | NONE   |  |
| US-A-5384028                           | 24-01-95         | JP-A- 7209242  | 11-08-95   |