

(19) World Intellectual Property Organization
International Bureau



(43) International Publication Date
31 July 2003 (31.07.2003)

PCT

(10) International Publication Number
WO 03/062588 A1

- (51) International Patent Classification⁷: **E21B 17/00**, 47/01
- (74) Agent: **ZINGERMAN, Scott, R.**; Fellers, Snider, Blankenship, Bailey & Tippens, P.C., 321 South Boston, Suite 800, Tulsa, OK 74103 (US).
- (21) International Application Number: PCT/US02/01321
- (81) Designated States (*national*): AE, AG, AL, AM, AT, AU, AZ, BA, BB, BG, BR, BY, BZ, CA, CH, CN, CO, CR, CU, CZ, DE, DK, DM, DZ, EC, EE, ES, FI, GB, GD, GE, GH, GM, HR, HU, ID, IL, IN, IS, JP, KE, KG, KP, KR, KZ, LC, LK, LR, LS, LT, LU, LV, MA, MD, MG, MK, MN, MW, MX, MZ, NO, NZ, OM, PH, PL, PT, RO, RU, SD, SE, SG, SI, SK, SL, TJ, TM, TN, TR, TT, TZ, UA, UG, UZ, VN, YU, ZA, ZM, ZW.
- (22) International Filing Date: 16 January 2002 (16.01.2002)
- (25) Filing Language: English
- (26) Publication Language: English
- (71) Applicants and
- (72) Inventors: **KOOMEY, Paul, C.** [US/US]; 5917 Crab Orchard Road, Houston, TX 77057-1421 (US). **SAVAGE, George, M.** [US/US]; 3124 Shore Drive, Grove, OK 74344 (US). **STRASSNER, Bernd, H. III** [US/US]; 1013 Bayou Woods Drive, College Station, TX 77840 (US). **CHANG, Kai** [US/US]; 2911 Camille Drive, College Station, TX 77845 (US).
- (84) Designated States (*regional*): ARIPO patent (GH, GM, KE, LS, MW, MZ, SD, SL, SZ, TZ, UG, ZM, ZW), Eurasian patent (AM, AZ, BY, KG, KZ, MD, RU, TJ, TM), European patent (AT, BE, CH, CY, DE, DK, ES, FI, FR, GB, GR, IE, IT, LU, MC, NL, PT, SE, TR), OAPI patent (BF, BJ, CF, CG, CI, CM, GA, GN, GQ, GW, ML, MR, NE, SN, TD, TG).

[Continued on next page]

(54) Title: RADIO FREQUENCY IDENTIFICATION TAGS FOR OIL DRILL STRINGS

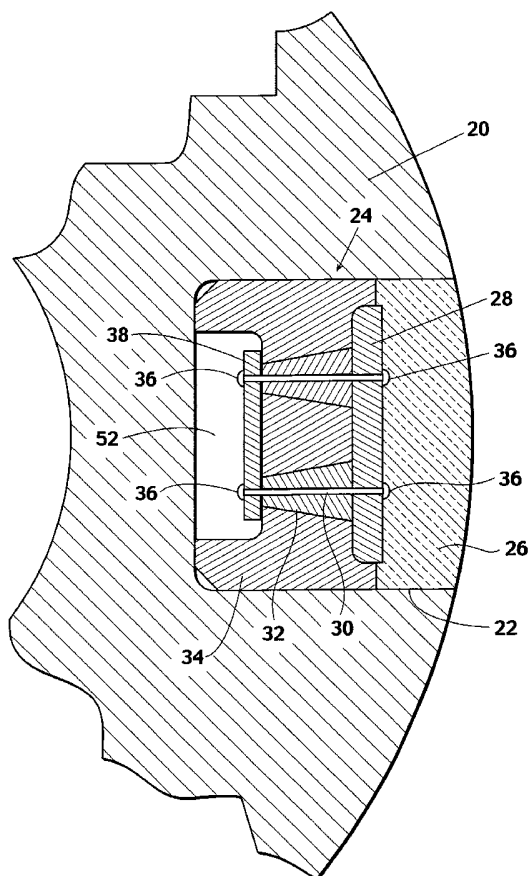

(57) Abstract: This invention provides a means for configuring, assembling and providing inhole protection to a Gigahertz or other radio frequency identification tags in recess holes machined in drill pipe and tools utilized in drilling oil and gas wells.



WO 03/062588 A1



Published:

— with international search report

For two-letter codes and other abbreviations, refer to the "Guidance Notes on Codes and Abbreviations" appearing at the beginning of each regular issue of the PCT Gazette.

RADIO FREQUENCY IDENTIFICATION TAGS FOR OIL DRILL STRINGS

5

Field of the Invention

[1] This invention relates to a means for the assembly, retention and physical protection of a radio frequency identification tag installed in recess holes machined in drill pipe and tools utilized in drilling oil and gas wells.

10

Background of the Invention

[2] Drill strings used in oil and gas drilling consist of many different type tubulars and represent a major financial investment. Deep wells often have in excess of 600 joints of drill pipe in the well bore at any given time and in addition to drill pipe, drill strings may include such tools as drill collars, reamers, stabilizers, crossover subs for different threaded connections, safety valves, bit subs, and special logging tools.

15
20

[3] A method of automatically identifying, tallying and tracking of uniquely serialized drill string components will be of considerable economic benefit to the oil drilling industry. Based on such an automatic identification system in-hole pipe tallies may be recorded, well depths determined, in-hole component inventories maintained, individual components may be tracked through the well bore, and calculation and measurements of individual component down hole service factors including fatigue wear may be accumulated for each joint. A rarely used method of identification employs a stenciled code stamped on the pipe that is often difficult to locate on the joint and requires the

25
30

identification to be cleaned, visually recognized, and then manually recorded or entered in a hand-held computer.

[4] Another approach has been using kilohertz radio frequency identification tags as an alternative to stenciling. A tag that has found limited use in drill strings is offered by the Indala Division of the Motorola Corporation who offers their model IT-52E Mini Disc Tag. These small kilohertz frequency tags have dimensions of 11.7 mm diameter by 3.2 mm thick and are normally contained in shallow recess holes machined in the drill pipe.

10

[5] Kilohertz tags require personnel to locate the tag and often remove drill mud or formation materials off the exposed surface whereby the identification code may be read by hand-held readers that must be positioned directly over the recessed tag at a distance less than a few millimeters. The process of identifying drill pipe by this means is laborious and requires considerable drill rig time that is exceedingly expensive. The requirement of a close read range is largely due to inability of the long wavelengths of the low frequency kilohertz signals to enter into the pipe recess to adequately energize a small tag antenna and has not proved adaptable to automatic identification of drill string components. Kilohertz tags have therefore been primarily limited to asset tracking and inventory control purposes.

[6] To overcome shortcomings of low frequency identification tags, an effort was given to modifying and adapting a longer read range Megahertz system to drill string identification. Following several years work, this effort was

25

abandoned due to the inability to devise a method of the mid-frequency wave length to enter into drill pipe protective recesses sufficiently deep as to transfer energy to the tag antenna to activate electronics and to return an identification code at a read distance necessary for drill string identification.

5

[7] Longer read distance high frequency identification systems in the Gigahertz ranges are extensively used for applications as automatic vehicle identification and toll collection. These radio frequency identification (RFID) systems include 915 MHz and 2.45 GHz such as supplied by the Amtech Division
10 of Intermec Technologies Corporation of Everett, Washington. A 5.8 GHz system for automatic vehicle tolling is being used in Europe and offered by Q-Free ASA of Trondheim, Norway. Despite good potential for long read distance capability, physical constraints have thus far prevented use of these systems for drill string identification.

15

[8] Although drill string identification is performed on the rig at atmospheric pressures and ambient surface temperatures, electronics must be protected against down-hole pressure that may reach 25,000 psi and the electronic components must be able to survive occasional 450°F bottom hole
20 temperatures. In addition to isolating the electronic circuitry from high well bore pressure and drill fluids, tags require physical protection such as required when pipe is being transported, handled on pipe racks, being made up in or broken out of mating drill string threaded joints with heavy duty tongs, and for the abrasion and pounding against the geologic formation walls while rotating the drill bit in the
25 hole or traversing the well bore.

[9] High well bore pressures will quickly and permanently disable electronics unless they may be isolated and protected and Gigahertz frequency systems antennas are typically a plate or patch that is too large to protect against well bore conditions and damage. A need, therefore, exists for a means to isolate and protect a Gigahertz frequency system and antenna from such high well bore pressures. It is an object of this invention to include a means for the installation and protection from physical damage of a Gigahertz frequency circular patch antenna in a tag assembly whereby protection in the well bore is provided for tag electronics at essentially atmospheric pressure. This invention is not limited to a Gigahertz frequency and mid-frequency and low-frequency identification tags with loop or coil antennas may also employ the features of this invention.

SUMMARY OF THE INVENTION

15

[11] This invention provides a means of configuring a drill string identification tag in a manner whereby the tag electronic circuits are retained at near atmospheric pressure and isolated from destructive well-bore pressures while the tag antenna may be subject to high well bore pressure and abuse common to oil and gas well drilling operations. Other features of this invention include relative ease of tag assembly at the time of manufacture and simplicity of installation of a tag assembly in a drill string component. One embodiment of this invention permits protection of relatively large electronic circuitry and employs a metal protective housing assembly. An alternative embodiment anticipates the use of the electronic circuits being contained in a millimeter dimensioned

25

integrated circuit, or ASIC, protected by a ceramic or composite material. This alternative configuration may be less expensive and offers the advantage of permitting recovery of an intact tag assembly from the drill string protective recess as desired for tag reinstallation in another drill string component or for tag
5 replacement in event of a malfunction.

[12] Both embodiments of the tag assembly are to be contained and protected within an approximate 1" diameter recess hole machined into a heavy wall section of a drill pipe tool joint, drill collar, sub, stabilizer or other down-hole
10 drill string component. The drill string component protective recess hole is drilled sufficiently deep to contain the overall height of the tag assembly and includes an electromagnetically conductive sacrificial plastic wear material extending from the antenna to be flush with the outside diameter of the component. The thickness of the plastic protective material is intended to permit component wear from a new
15 outside diameter to a pre-determined worn diameter usually specified by an American Petroleum Institute standard. The tag wear and protection is of a plastic type material that has a low dielectric constant to minimize radio frequency signal attenuation, is resistant to chemicals and fluid adsorption, and has a satisfactory temperature and strength capability. One such material that satisfies these
20 requirements is a Teflon[®] compound.

[13] The Electromagnetics and Microwave Laboratory of Texas A&M University Department of Electrical Engineering has recently completed the development of 5.8 Gigahertz frequency tag circuitry specifically designed for drill
25 string identification. Wave lengths of a 5.8 Gigahertz frequency have been

demonstrated to be sufficiently short to allow entry down into a drill pipe protective recess so as to communicate with and impart energy to a small circular patch antenna of an identification tag. In this development, microwave frequency passive backscatter identification system electronics have been built and tested
5 that are capable of identification reads through drill mud films to a recessed tag and which has heretofore been considered impractical and untried for drill string identification. Texas A&M University intends to license the technology for drill string identification through their Technology Licensing Office and a Formal Patent Application titled "System and Method for Communicating Information
10 Associated with a Drilling Component" has been filed with a date of July 16, 2001 Serial No. 09/906,957. This communications technology offers one means of enabling radio frequency automatic drill string identification and makes practical the applications and benefits described in the Savage Patent No. 5,202,680.

15 [14] This invention is well suited for the newly developed Texas A&M University technology which thus far has utilized electronic circuits composed of one or more etched circuit boards on which are mounted various electronic components. One embodiment of this invention utilizes a metal tag housing to protect these relatively large electronic circuits at essentially atmospheric
20 pressure. An alternative embodiment of this invention consists of tag housing of a ceramic or composite material retaining and protecting a small integrated circuit at atmospheric pressure. One such non-metallic tag housing material is Alumina Oxide that has a compressive strength of approximately 375,000-pounds/square
25 inch that is adequate considering the available wall thickness of the ceramic protection.

[15] Coaxial antenna leads are required for high frequencies and one or more leads must penetrate the ceramic or metal from the electronics enclosure to the antenna remote from the circuitry. The embodiment of this invention that
5 utilizes the ceramic or composite circuit housing and antenna may be encapsulated by a plastic type material for the purpose of protecting, cushioning and retaining a fragile ceramic or composite housing within the component recess. It is intended the same encapsulation material will provide sacrificial wear and a residual cover over the tag assembly as the drill string component is worn
10 to an allowable minimum outside diameter.

[16] In the embodiment of the metal tag housing, the coaxial lead wire may be pressure sealed from the electronics chamber by means of a low expansion conductor wire used in conjunction with compatible glass, ceramic or
15 composite material characteristics. The antenna lead wire is thereby insulated from the metal tag housing as to form a coaxial antenna lead required for high frequencies. Several sources offer glass-to-metal sealing low expansion wire such as Dumet or Kovar and include Ed Fagan Inc. 769 Susquehanna Ave., Franklin Lakes, N.J. 07417. Glass suitable for use with these alloys to insulate
20 and seal antenna leads is available as Corning 7052 or 7050, Kimble EN-1 and others. Similar capability ceramic-glass is an Alumina Oxide available from several sources that include LTD Ceramics Texas, 12122 Technology Drive, Austin, Texas 78727.

[17] Pressure seal of coaxial antenna leads for the alternative embodiment ceramic or composite tag housing may be accomplished in a similar manner as for the metal tag housing except a small metal tube or wire braid will replace the function of the metal of the tag housing and serve as the outer coaxial
5 conductor. The outer conductor tube or wire braid of the coaxial lead may contain the glass, ceramic or composite insulated and sealed inner wire and may then be placed in the tag housing through a drilled hole of a machined tag housing or else during forming of housing segments prior to sintering or curing the materials. As this alternative non-metallic housing allows installation of a coaxial lead in the
10 ceramic or composite at the time of housing manufacture, the coaxial leads may be a curved or irregular shape connecting the integrated circuit electronics and the antenna to accommodate differences in antenna lead and electronic circuit spacing.

15 [18] It is intended the features of this invention will not be limited to a 5.8 GHz frequency but may be used with other Gigahertz, Megahertz and kilohertz frequency tag assemblies and antenna configurations.

BRIEF DESCRIPTION OF THE DRAWINGS

20

[19] FIG. 1 is a drill pipe tool joint pin end illustrating an identification tag protective recess hole containing an RF identification tag assembly.

[20] FIG. 2 is an exploded view of an identification tag assembly.

25

[21] FIG. 3 is a partial cross-section of a drill pipe tool joint pin end with an identification tag assembly in the tool joint protective recess.

[22] FIG. 4 is a partial cross-section of a drill pipe tool joint pin end
5 illustrating an alternate location of the tag assembly seat in the recess.

[23] FIG. 5 is a partial cross-section of a drill pipe tool joint pin end with an identification tag integrated circuit protected in a ceramic housing.

10 DESCRIPTION OF THE PREFERRED EMBODIMENT

[24] Referring to Figure 1, the pin end of a drill pipe tool joint **20** has an approximate 1" inside diameter protective recess hole **22** drilled to retain and partially protect radio frequency identification tag assembly **10**. The recess hole is
15 drilled to a depth that provides tag protection throughout the useful service life of the tool joint and until the outside diameter of the tool joint is worn in well bore service to a predetermined reduced diameter that maintains joint structural integrity.

[25] Now referring to Figure 2, an exploded view of one embodiment of the tag illustrates complete tag assembly **10**. Tag assembly **10** includes low dielectric constant electromagnetically conductive plastic type protective material **26**. Tag antenna **28** may be in the form of a coil or loop but for a microwave frequency such as 5.8 GHz will be a circular patch over substrate and ground
25 plane layers. A shallow recess **44** having approximately the same inside diameter

as the patch antenna substrate and ground plane outside diameter is provided in the tag housing **34** to position and help retain the antenna in said tag housing. One or more antenna leads **30** are contained within ceramic, glass or composite material insulation **32** to effect a coaxial connection through the tag housing to tag electronic circuits **38**. The coaxial antenna lead insulation **32** is of a truncated cone shape such that the tag assembly **10** in this embodiment forms a tapered plug which will provide an initial seal against well bore pressure. Specifically, in the presence of high well bore pressure, a substantial force is applied to the tapered plug thereby wedging and increasing tightness (retention in the drill pipe protective recess **22**) and sealing capability.

[26] Continuing with reference to Figure 2, the outside diameter of the metal tag housing **34** is dimensioned to provide an interference fit with the pipe protective recess inside diameter **23** and enable a metal-to-metal seal for isolating the tag electronics against well bore pressure and to retain the tag assembly in protective recess **22**. A section of slightly reduced outside diameter **40** of tag housing **34** facilitates insertion and installation of tag assembly **10** in the protective drill string recess **22**. A secondary metal-to-metal seal of the electronic circuitry against well bore pressure is provided by tag shoulder **42** seating on the bottom **25** (Fig. 1) of the drill string component protective recess **22**. This seal is made more effective as well bore pressure acting on the projecting area **41** of tag assembly **10** results in a large force being exerted against the projecting area **41** of said tag shoulder **42** so as to produce a high unit contact pressure that will effect a metal-to metal seal with the bottom **25** of the protective tool joint recess **22**.

[27] Tag housing **34** includes a proximal surface and a distal surface. The proximal surface of tag housing **34** is positioned adjacent antenna **28** and sacrificial wear material **26**. Tag electronics **38** are positioned adjacent to the
5 distal surface of tag housing **34**.

[28] With further reference to Figure 2, the plug of plastic type protective and sacrificial wear material **26** fills the protective recess **22** (Fig. 1) above the proximal surface of tag housing **34** and tag antenna **28** so as to be flush with the
10 outside diameter surface **21** of the tool joint **20**. The sacrificial plastic material **26** prevents drill mud or geological formation materials from filling the space above tag antenna **28** thereby attenuating identification signals and also serves to buffer the tag assembly **10** against in-hole damage or during handling on the drill rig. The sacrificial wear material **26** wears with the drill string component outside
15 diameter **21** (Fig. 1) and is an electromagnetically conductive plastic type material having a low dielectric constant. If a coil or loop antenna is employed rather than the patch antenna **28** of the preferred embodiment, an antenna standoff above an electrically conductive tag housing will be necessary and said coil or loop antenna will be then contained in the protective and wear plastic material **26**.

20

[29] Although it is understood that alloy steel might be employed, in the preferred embodiment of the metal tag housing **10**, a high strength material having a low Young's Modulus is employed. One advantage of a low Young's Modulus material is in minimizing the force required to install and seat tag
25 housing **10** into the interference fit of the component recess **22**. Another

feature/benefit of a low modulus material is that as the drill string component recess **22** distorts due to high service induced stresses, the elasticity of a low Modulus material enables the diameter of tag housing **34** that has been compressed due to the interference fit to recover and contribute to maintaining a metal to metal pressure seal. A material well suited for tag housing **34** in the preferred embodiment is Titanium which has a Young's Modulus of approximately one half that of steel, is resistant to corrosion, has a coefficient of thermal expansion approximating that of steel and may be alloyed to provide the high yield strength needed to minimize the tag housing dimensions. An additional feature of titanium, separate and apart from the low Young's Modulus is that Titanium alloys have a high Poisson's Ratio (approximately .36) such that when high well bore pressure is transmitted through the plastic protective material **26** to the projected exposed surface area **43** of the tag housing, the compression force and strain will tend to elastically expand the diameter of tag housing **34** and exert an additional radial contact and sealing force against the wall of the protective recess **22**. One such Titanium alloy in common use that satisfies these requirements is Ti-6Al-4V.

[30] Referring next to Figure 3, this illustration represents a partial cross-section of the tool joint **20** and shows the metal tag housing assembly **10** in place within the drill string component recess hole **22**. Said metal tag housing **34** contains one or more ceramic or composite material truncated cones **32** to insulate the wire antenna lead(s) **30** as to form a coaxial antenna lead whereby the metal housing serves as the outer coaxial conductor. The tag assembly **10** rests on the bottom **25** of the recess hole **22** and contains cavity **52** machined to

accommodate tag electronics **38** which may be in the form of an integrated circuit or a circuit board on which are mounted electronic components. High temperature solder joints **36** connect coaxial antenna leads **30** to the antenna **28** and the electronic circuits **38**. This tag configuration enables and facilitates tag assembly and manufacture including accessibility to solder joints and the means of placement and installation of the electronic circuits **38**.

[31] Reference is next made to Figure 4 which is an alternate embodiment **80** of the metal tag housing of the present invention. Alternate embodiment metal tag housing **80** does not contain an electronics cavity (**52** in Fig. 3) in the metal tag housing but instead the electronics cavity **82** is formed by a reduced hole diameter machined into the bottom **86** of the protective recess **86** of the drill string component **88**. The electronic circuitry **90** in the form of circuit boards or an integrated circuit continues to be attached to the underside of the alternative shape tag housing **92**. The alternate embodiment tag housing **92** lands on recess shoulder **94** to provide a supplementary metal-to-metal seal when under high well bore pressure and contact force(s). In addition to an interference fit of tag housing **92** in protective recess **84**, a secondary elastomer pressure seal **96** retained in seal groove **98** may also prevent down-hole pressure and fluids from accessing electronics cavity **82**. As tag housing **92** has relatively little overall height and provides limited space for a reduced lower end diameter, to assist in insertion of tag housing **92** into protective recess **84** a short section of the of the component recess **84** aperture may be tapered to a slightly larger inside diameter to introduce metal tag housing **92**.

[32] Still referring to Figure 4 an alternative embodiment of the glass or ceramic antenna lead coaxial cable insulation (**32** of Fig. 3) is replaced with cylindrical shaped insulation (collectively **100**) fabricated of similar materials as the truncated cone **32** illustrated in Figure 3. A shoulder **102** in tag housing **92** seats and limits travel of the cylindrically shaped antenna lead insulator **100** and prevents pressure from forcing the cylindrical shape through the tag housing **92**. The pressure seal between the cylindrical hole drilled through the tag housing **92** (to accommodate cylindrical insulator **100**) and the cylindrical insulator **100** will be by means of a high temperature sealant (available commercially) inserted at the time of manufacture.

[33] Additional or alternative seals used to seal metal tag housing **92** inside protective recess **84** and against well bore pressure may include a metallic gasket placed between the mating recess shoulder **94** and the tag housing **92**. Although drill mud hydrostatic heads will hold the tag assembly **80** firmly in place when in the well bore, during surface handling of drill string component **88**, the identification tag assembly **80** can be further retained in protective recess **84** by additional methods to the preferred press or interference fit and include (but are not limited to) coining, a section of a fine pitch thread for the tag housing and mating recess, a threaded hold-down nut, or by a bonding material.

[34] The embodiments of a metal tag housings (**34** and **92**) as illustrated in Figures 2, 3, and 4 are well adapted to relatively large electronic circuitry mounted on a circuit board as developed by the Texas A&M University for the above-described prototype tags. Upon substitution of the circuit board

construction method with an integrated circuit, or ASIC, that has physical dimensions of only a few millimeters, a ceramic or composite material tag housing can offer the protective features of a metal housing and may have an advantage in housing fabrication costs will also enable a means of recovery of the tag housing assembly (34 or 92) from the component recess (22 and 84, respectfully).

[35] Referring now to Figure 5, the tag housing 120 of this embodiment is a ceramic or composite material in which integrated circuit 112 is situated in housing electronics cavity 114. Tag housing 120 is of a material having the high compression strength required for high bottom hole pressure protection and may be of various ceramic materials or composites including the glass-ceramic Alumina Oxide. The ceramic or composite tag housing 120 of this embodiment may be machined from solid stock or formed of powdered materials and sintered in upper and lower segments. One or more prefabricated coaxial leads 116 that will connect integrated circuit 112 to the tag antenna 118 and will be inserted through hole(s) drilled in the tag housing segment 120 or alternatively be placed in the powdered material during forming of the segment and will be sealed during sintering or curing of the tag housing material. The tag integrated circuit 112 is then installed and connected with high temperature solder joint 122 to the one or more coaxial antenna lead(s) 116. The segments of the tag housing are subsequently joined and sealed by a solder glass, high temperature bonding agent, brazing metal or similar means and the tag antenna 118 attached and connected with high temperature solder. The shape of the alternative embodiment ceramic or composite tag housing 120, designed to withstand high

pressure, will ideally be of an approximate cylindrical shape along its length and will permit a large radius **124** at the juncture of the wall of recess **130** and recess bottom **128** that serves to reduce stress concentration factors in this area of the drill string component **111**.

5

[36] After assembly of the tag housing **120**, to include tag antenna **118**, a layer of a low dielectric constant electromagnetically conductive plastic material **126** surrounds and encapsulates the ceramic alternate embodiment tag housing **120** to cushion and adsorb shock because some housing materials are often
10 brittle and subject to fracture, compensate for differences in coefficients of thermal expansion and protect from component stress induced strains. A thicker section **127** of plastic material **126** is an integral part of the plastic encapsulation and will extend to fill the volume above the tag antenna to be flush with the outside diameter of drill string component **111** and provide a wear volume and a
15 buffer for protection against well bore pounding and rubbing against the walls of the hole, drill pipe tong teeth indentations and deformation and for handling damage on the surface pipe racks or during shipping.

[37] Plastic encapsulation material **126** will be bonded to tag housing
20 **120** and the entire assembly **110** will be anchored and retained in protective recess **130** by means of a fine thread, or "v" or "u" shaped grooves **132** in the wall of component recess **130**. Some tag electronics (such as **112**) and fields of antenna **118** may be polarized and require a specific orientation of the antenna **118** in the protective recess **130** in relation to the axis of drill string component
25 **111** so that tag **110** can be read by fixed interrogator system antennas (not

shown). Positive and firm bottoming out (as shown in Fig. 5) of the tag **110** in the component protective recess **130** is required and the orientation of tag **110** is dependent on threads **132** and screwing assembly **110** in recess **130** will be difficult and happenstance. Therefore, an interference fit plastic encapsulation, a bonding material that bonds to the plastic encapsulation, or a combination of both (collectively shown as **126**) will be the preferred tag retention and anchoring method.

[38] Removal of tag assembly **110** for replacement or reuse may be accomplished by means of a hole saw drilling out encapsulation material **126** between tag housing **120** and the wall of the component recess **130**. New or additional plastic encapsulation material **126** may then be bonded to the recovered tag **110** to replace the material removed in salvaging the tag and the tag **110** is reinstalled as desired.

[39] While the above description contains many specifics, they should not be construed as limitations on the scope of the invention, but rather as an exemplification of the preferred embodiments and applications thereof. It is intended the foregoing embodiments and features to be applicable to other identification tag applications requiring the features and the protection offered by this invention.

CLAIMS**What is claimed is:**

1. An apparatus for retention and protection of a radio frequency
5 identification tag in a recess having a bottom in an oil drill string, comprising:

a tag housing press fit into the recess in the oil drill string;

said tag housing having a proximal surface and a distal surface
10 wherein said distal surface is adjacent the bottom of the recess;

a tag electronic circuit positioned adjacent said distal surface of said
tag housing;

15 a tag antenna positioned adjacent said proximal surface of said tag
housing;

at least one antenna lead extending from said tag electronic circuit to
said tag antenna;

20 a plug of protective material positioned adjacent said proximal surface
of said tag housing covering said tag housing and said tag antenna.

2. The apparatus of claim 1 wherein said tag housing is constructed of a
25 material having a low Young's Modulus.

3. The apparatus of claim 2 wherein said tag housing is constructed of titanium.
4. The apparatus of claim 1 wherein said tag housing is constructed of
5 ceramic.
5. The apparatus of claim 1 wherein said plug surrounds and encapsulates said tag housing.
- 10 6. The apparatus of claim 5 wherein said plug further surrounds and encapsulates said tag antenna.
7. The apparatus of claim 1 wherein said plug is an electromagnetically conductive material.
15
8. The apparatus of claim 7 wherein said plug is an electromagnetically conductive plastic type material.
9. The apparatus of claim 8 wherein said plug is an electromagnetically
20 conductive plastic type material having a low dielectric constant.
10. The apparatus of claim 1 wherein said antenna is a patch antenna.
11. The apparatus of claim 1 wherein said antenna is a coil antenna.

12. The apparatus of claim 1 wherein said at least one antenna lead extends through said tag housing.
13. The apparatus of claim 1 wherein said at least one antenna lead includes
5 insulation thereon thereby insulating said at least one antenna lead from said tag housing.
14. The apparatus of claim 13 wherein said insulation is of a truncated cone shape and said tag housing includes at least one truncated cone shaped receiver
10 shaped to receive said at least one antenna lead having said truncated cone shaped insulator thereon.
15. The apparatus of claim 13 wherein said insulation is of a cylindrical shape and said tag housing includes at least one cylindrically shaped receiver shaped to
15 receive said at least one antenna lead having said cylindrically shaped insulator thereon.
16. The apparatus of claim 1 wherein said distal surface of said tag housing includes a cavity therein to receive said tag electronic circuit.

1 / 5

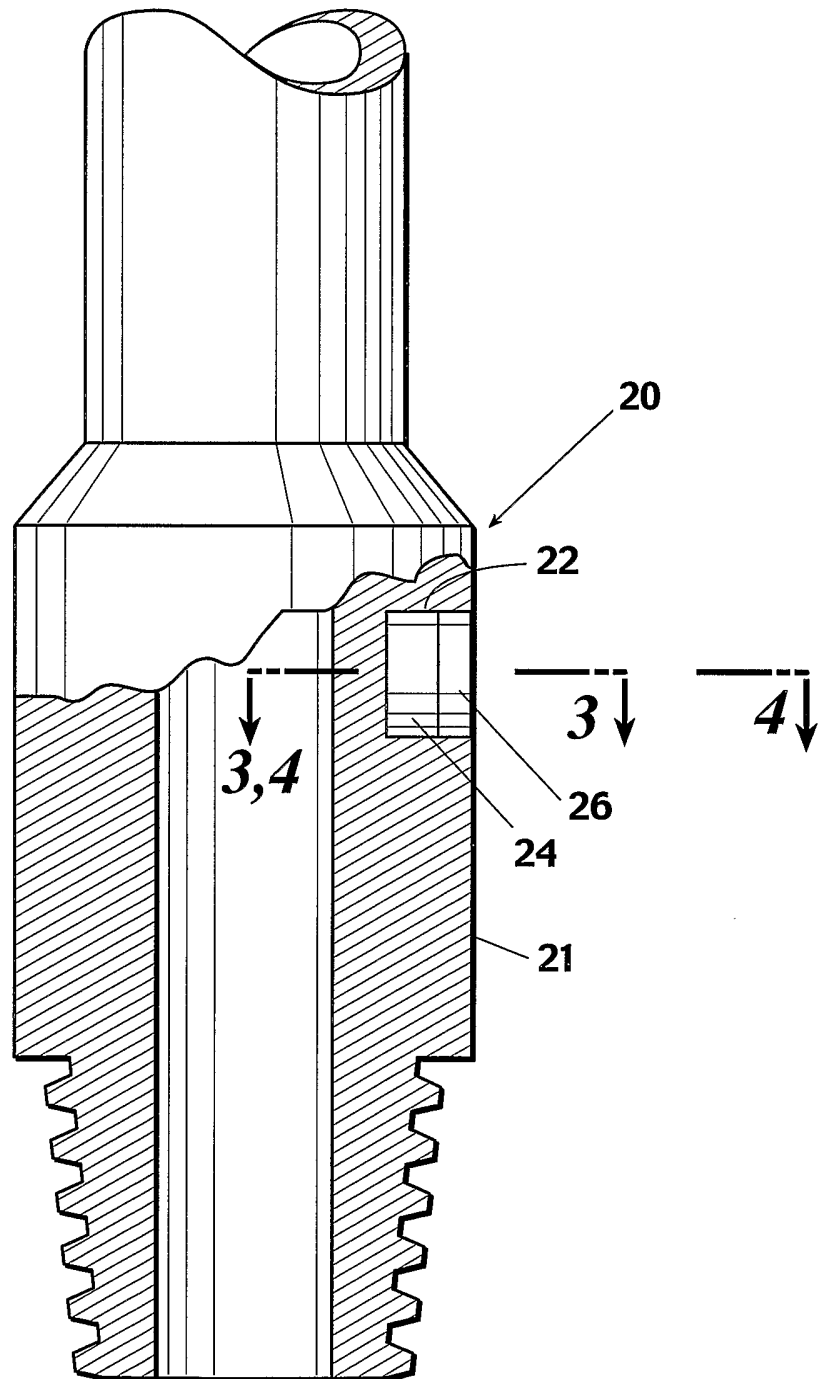
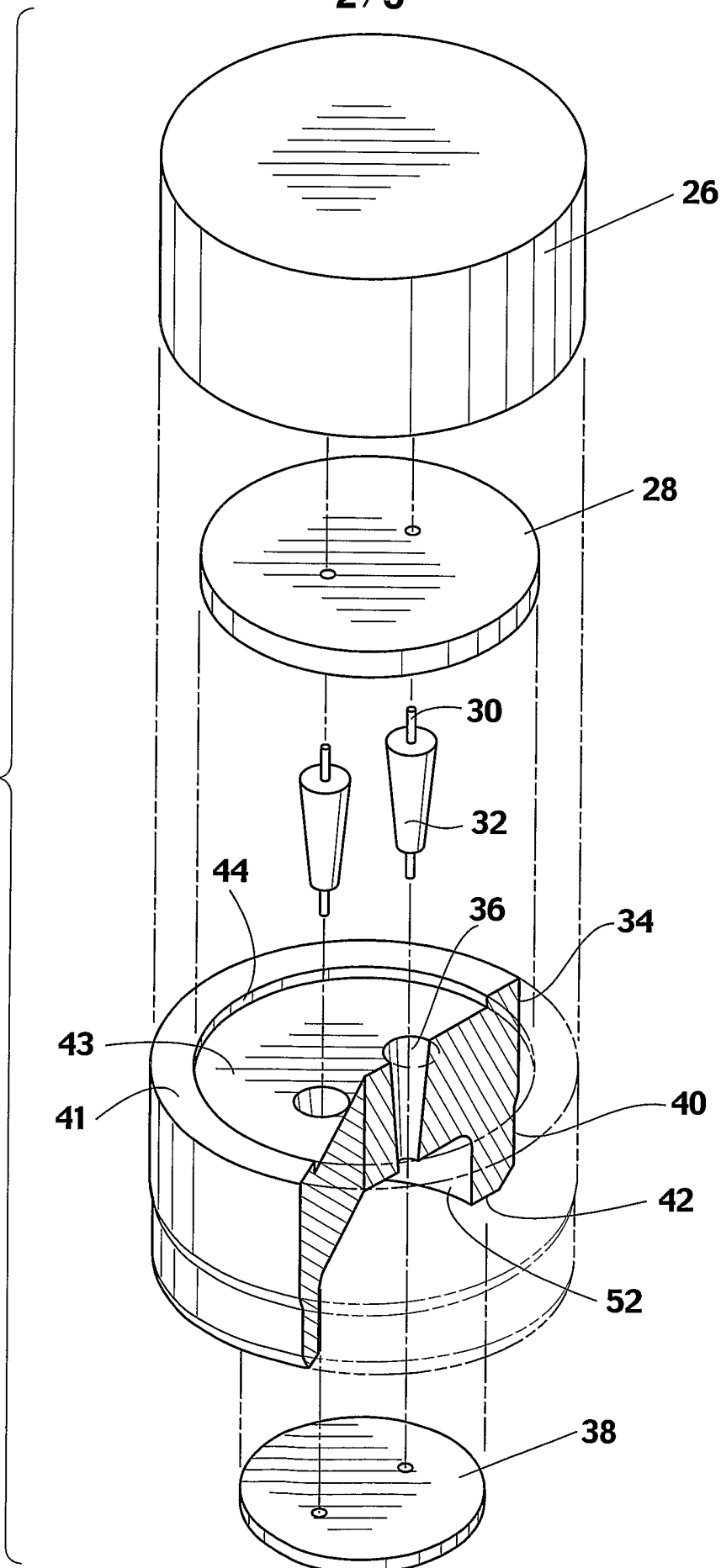

Fig. 1

2/5

Fig. 2



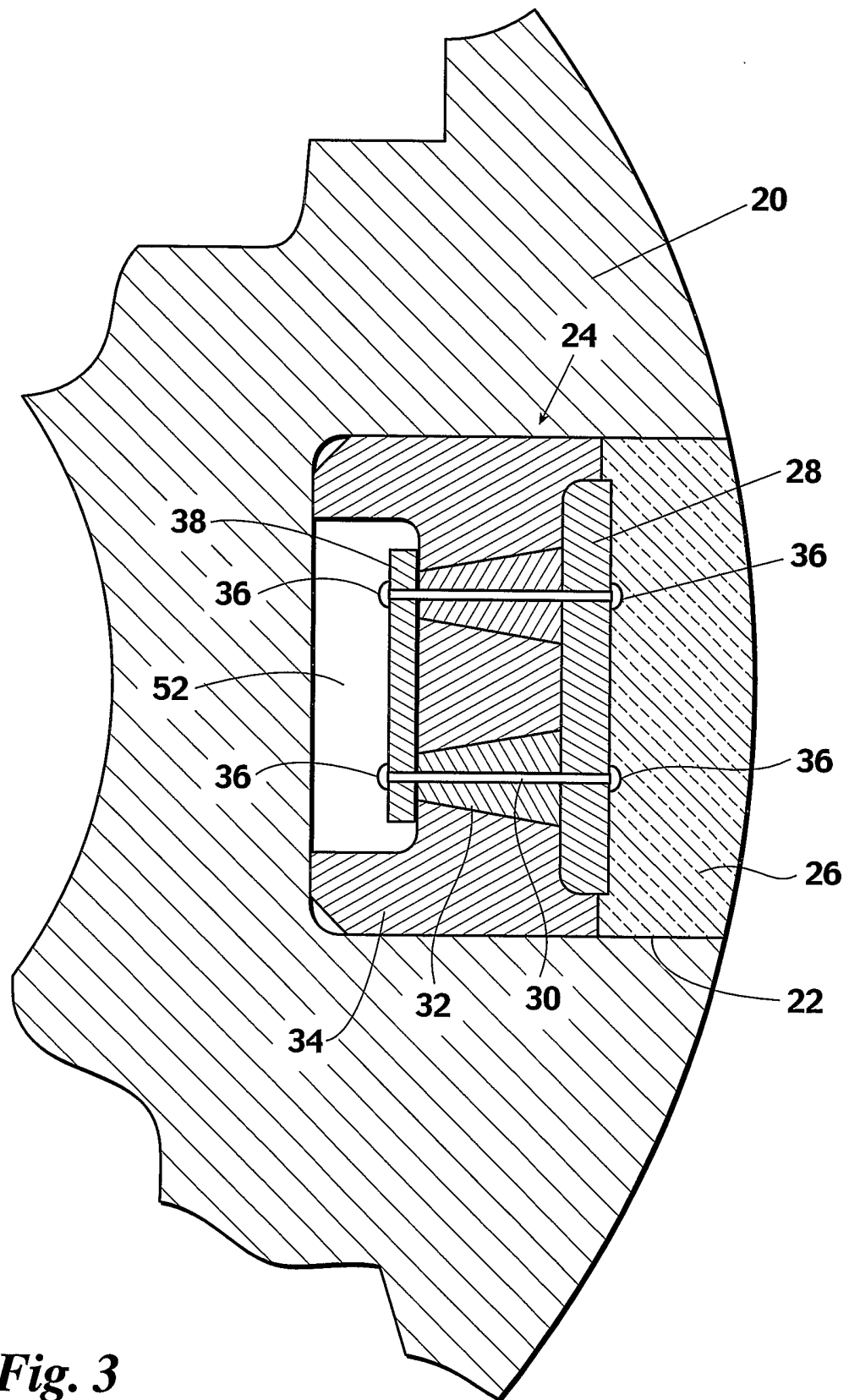

Fig. 3

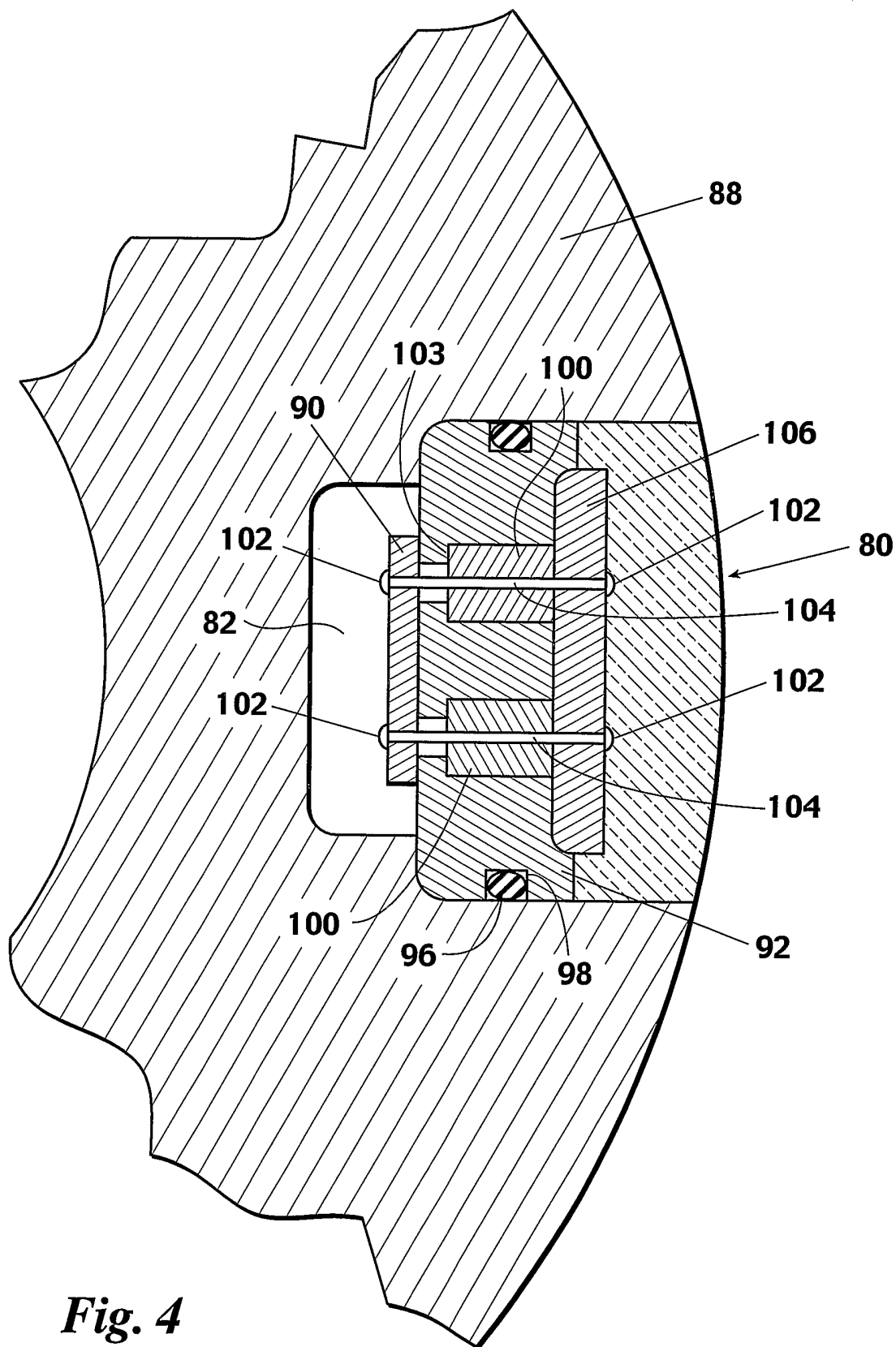

Fig. 4

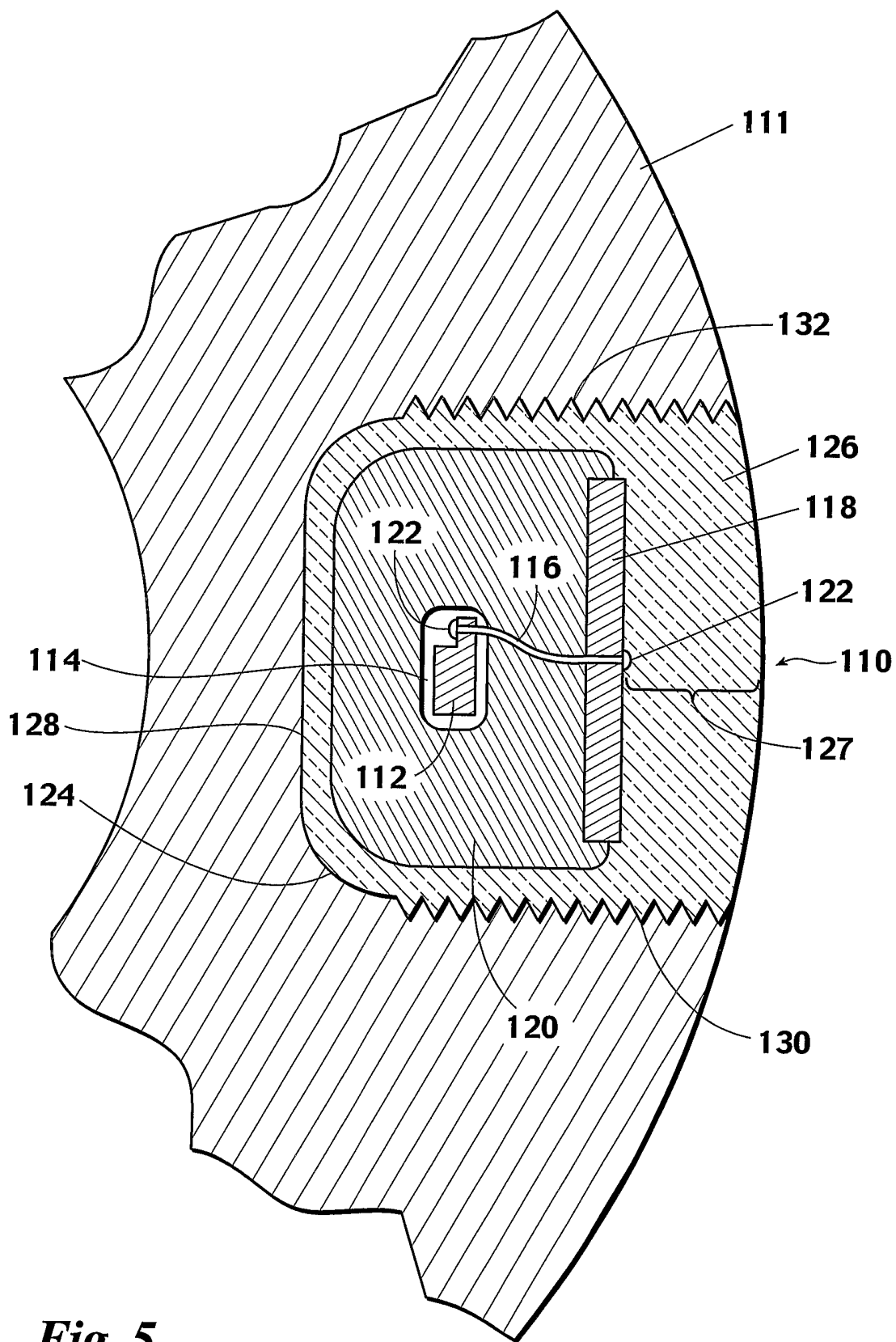

Fig. 5

INTERNATIONAL SEARCH REPORT

International Application No

PCT/US 02/01321

A. CLASSIFICATION OF SUBJECT MATTER
 IPC 7 E21B17/00 E21B47/01

According to International Patent Classification (IPC) or to both national classification and IPC

B. FIELDS SEARCHED

Minimum documentation searched (classification system followed by classification symbols)
 IPC 7 E21B G06K

Documentation searched other than minimum documentation to the extent that such documents are included in the fields searched

Electronic data base consulted during the international search (name of data base and, where practical, search terms used)

EPO-Internal, PAJ, WPI Data

C. DOCUMENTS CONSIDERED TO BE RELEVANT

Category *	Citation of document, with indication, where appropriate, of the relevant passages	Relevant to claim No.
A	WO 00 79239 A (HITEC ASA ;HALVORSEN HALVOR (NO)) 28 December 2000 (2000-12-28) page 3, line 1 -page 5, line 21 ---	1
A	US 5 142 128 A (PERKIN GREGG S ET AL) 25 August 1992 (1992-08-25) column 4, line 15 - line 68; figures 2,4 ---	1
A	US 6 100 804 A (DUAN DAH-WEIH ET AL) 8 August 2000 (2000-08-08) column 5, line 32 - line 50; figures 10,12 ---	1
A	GB 2 247 904 A (AXL SYSTEMS LTD) 18 March 1992 (1992-03-18) page 2, line 25 - line 32; figure 1 ---	1
	-/--	

Further documents are listed in the continuation of box C.

Patent family members are listed in annex.

* Special categories of cited documents :

- *A* document defining the general state of the art which is not considered to be of particular relevance
- *E* earlier document but published on or after the international filing date
- *L* document which may throw doubts on priority claim(s) or which is cited to establish the publication date of another citation or other special reason (as specified)
- *O* document referring to an oral disclosure, use, exhibition or other means
- *P* document published prior to the international filing date but later than the priority date claimed

- *T* later document published after the international filing date or priority date and not in conflict with the application but cited to understand the principle or theory underlying the invention
- *X* document of particular relevance; the claimed invention cannot be considered novel or cannot be considered to involve an inventive step when the document is taken alone
- *Y* document of particular relevance; the claimed invention cannot be considered to involve an inventive step when the document is combined with one or more other such documents, such combination being obvious to a person skilled in the art.
- *Z* document member of the same patent family

Date of the actual completion of the international search

11 September 2002

Date of mailing of the international search report

18/09/2002

Name and mailing address of the ISA

European Patent Office, P.B. 5818 Patentlaan 2
 NL - 2280 HV Rijswijk
 Tel. (+31-70) 340-2040, Tx. 31 651 epo nl,
 Fax: (+31-70) 340-3016

Authorized officer

Dantine, P

INTERNATIONAL SEARCH REPORT

International Application No
PCT/US 02/01321

C.(Continuation) DOCUMENTS CONSIDERED TO BE RELEVANT

Category °	Citation of document, with indication, where appropriate, of the relevant passages	Relevant to claim No.
A	US 4 698 631 A (KELLY JR JOSEPH L ET AL) 6 October 1987 (1987-10-06) column 2, line 7 - line 38; figures 4,7 -----	1
A	US 5 202 680 A (SAVAGE GEORGE M) 13 April 1993 (1993-04-13) cited in the application column 6, line 1 - line 25; figure 3 -----	1
A	US 5 654 693 A (COCITA KEITH) 5 August 1997 (1997-08-05) column 1, line 35 - line 58; figure 2 -----	1

INTERNATIONAL SEARCH REPORT

Information on patent family members

International Application No PCT/US 02/01321

Patent document cited in search report	A	Publication date	Patent family member(s)	Publication date
WO 0079239	A	28-12-2000	NO 992950 A AU 4958500 A WO 0079239 A1	18-12-2000 09-01-2001 28-12-2000
US 5142128	A	25-08-1992	AT 161987 T CA 2081908 A1 DE 69128620 D1 DE 69128620 T2 DK 527890 T3 EP 0527890 A1 WO 9117514 A1 US 5360967 A	15-01-1998 05-11-1991 12-02-1998 20-05-1998 09-02-1998 24-02-1993 14-11-1991 01-11-1994
US 6100804	A	08-08-2000	WO 0026856 A2	11-05-2000
GB 2247904	A	18-03-1992	WO 9205533 A1	02-04-1992
US 4698631	A	06-10-1987	CA 1291557 A1	29-10-1991
US 5202680	A	13-04-1993	NONE	
US 5654693	A	05-08-1997	NONE	