



US 20100101783A1

(19) **United States**
(12) **Patent Application Publication**
Vinegar et al.

(10) **Pub. No.: US 2010/0101783 A1**
(43) **Pub. Date: Apr. 29, 2010**

(54) **USING SELF-REGULATING NUCLEAR REACTORS IN TREATING A SUBSURFACE FORMATION**

Related U.S. Application Data

(60) Provisional application No. 61/104,974, filed on Oct. 13, 2008, provisional application No. 61/168,498, filed on Apr. 10, 2009.

(76) Inventors: **Harold J. Vinegar**, Bellaire, TX (US); **Scott Vinh Nguyen**, Houston, TX (US)

Publication Classification

(51) **Int. Cl.**
E21B 43/24 (2006.01)
F24J 3/00 (2006.01)
(52) **U.S. Cl.** **166/247; 376/275**

Correspondence Address:
SHELL OIL COMPANY
P O BOX 2463
HOUSTON, TX 772522463

(57) **ABSTRACT**

An in situ heat treatment system for producing hydrocarbons from a subsurface formation includes a plurality of wellbores in the formation. At least one heater is positioned in at least two of the wellbores. A self-regulating nuclear reactor provides energy to at least one of the heaters to increase the temperature of at least a portion of the formation to temperatures that allow for hydrocarbon production from the formation. Heat input to at least a portion of the formation over time at least approximately correlates to a rate of decay of the power from the self-regulating nuclear reactor.

(21) Appl. No.: **12/576,722**

(22) Filed: **Oct. 9, 2009**

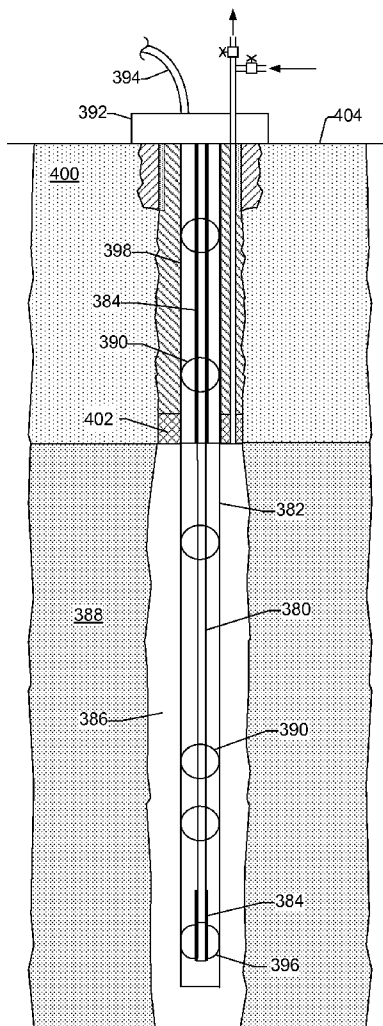

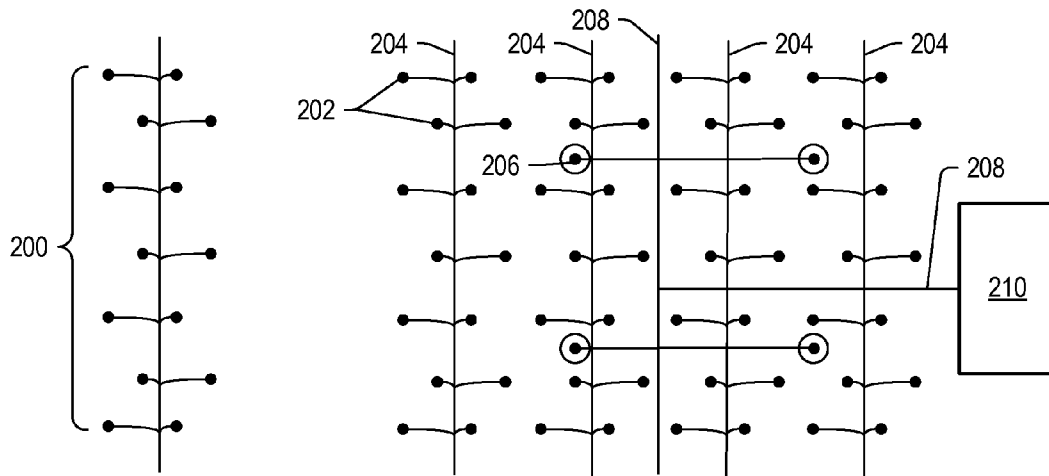

FIG. 1

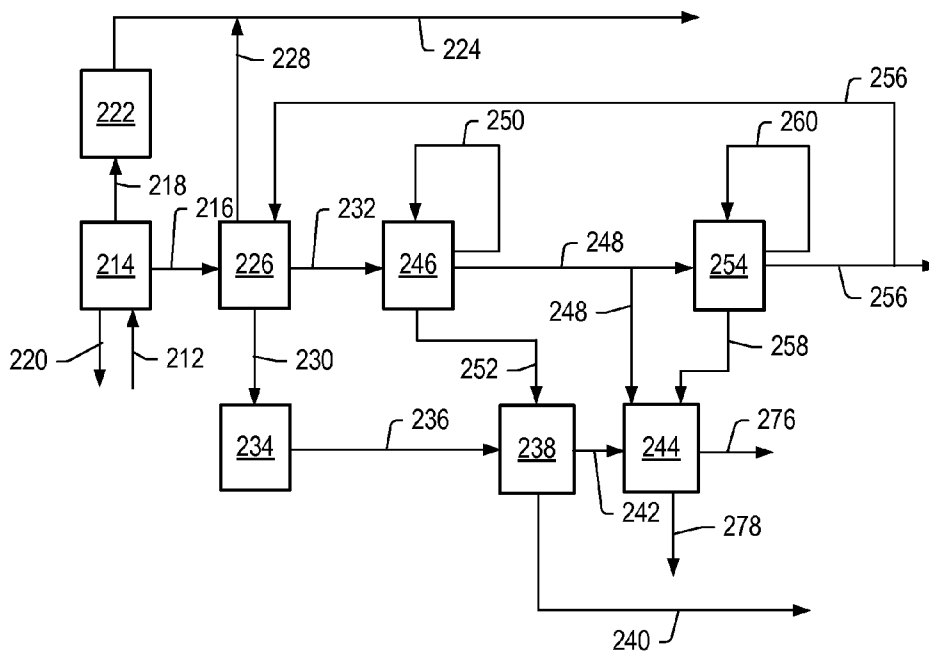

FIG. 2

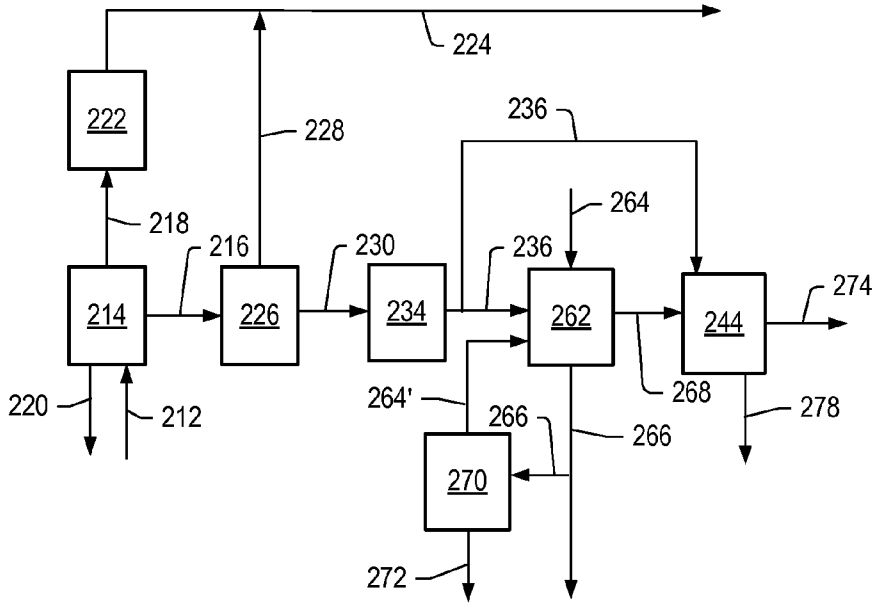

FIG. 3

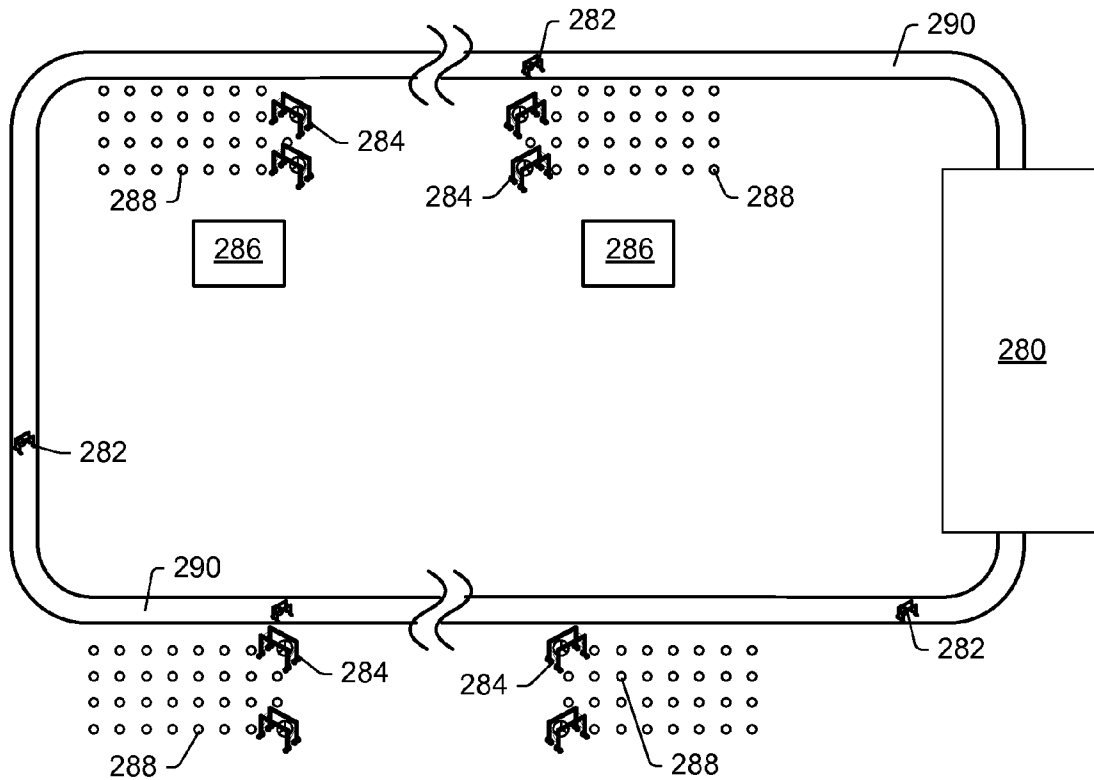
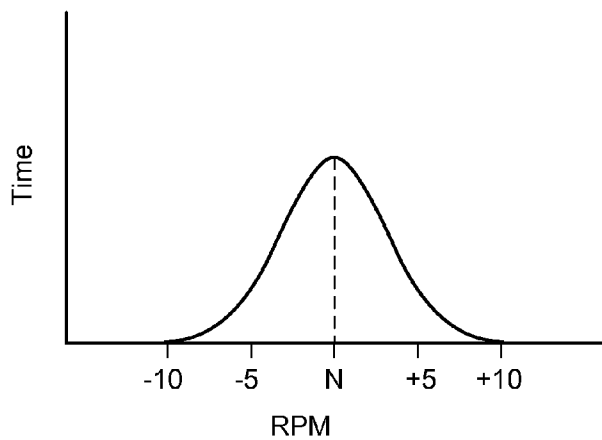
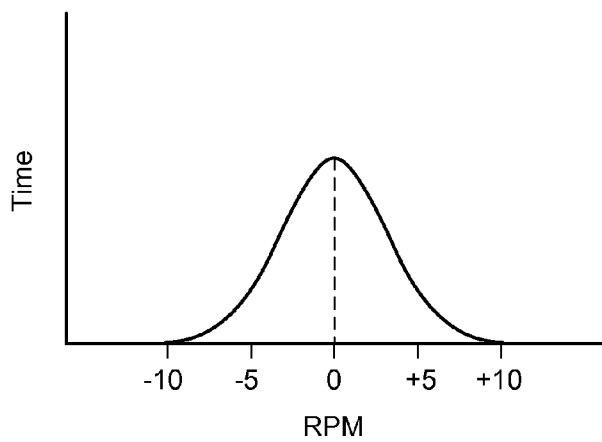
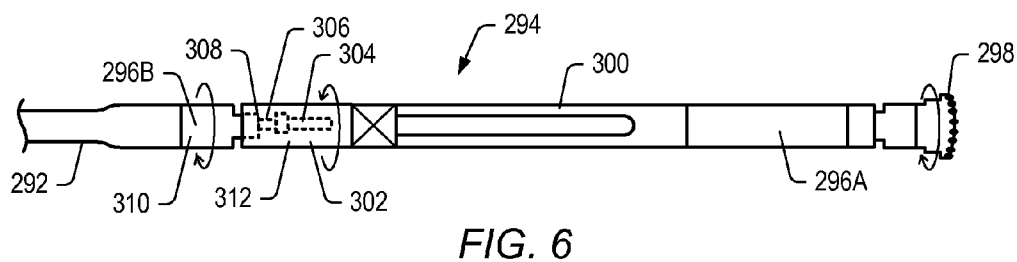
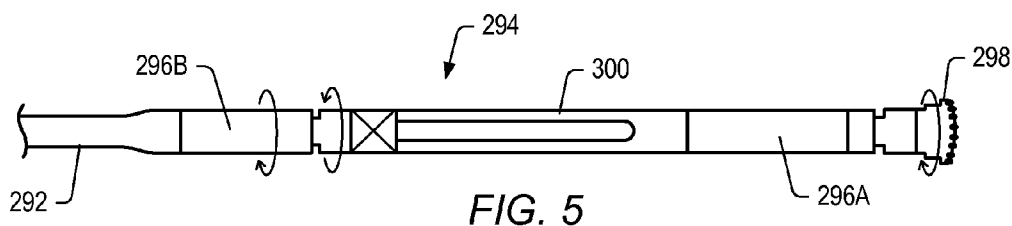

FIG. 4



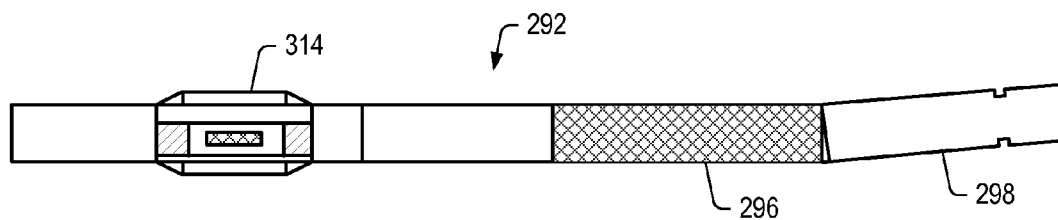

FIG. 9

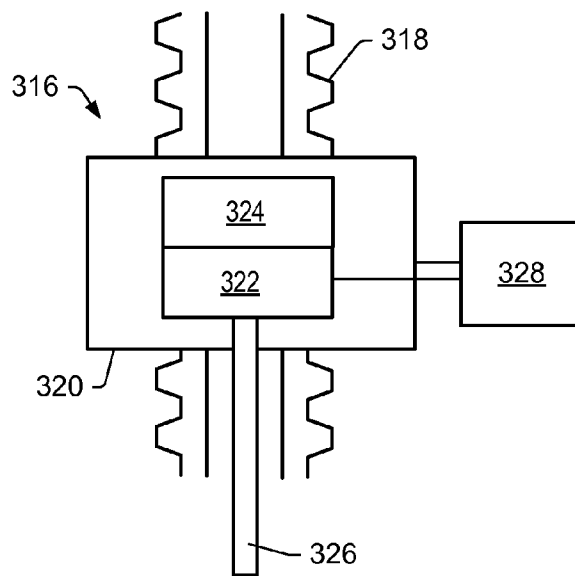
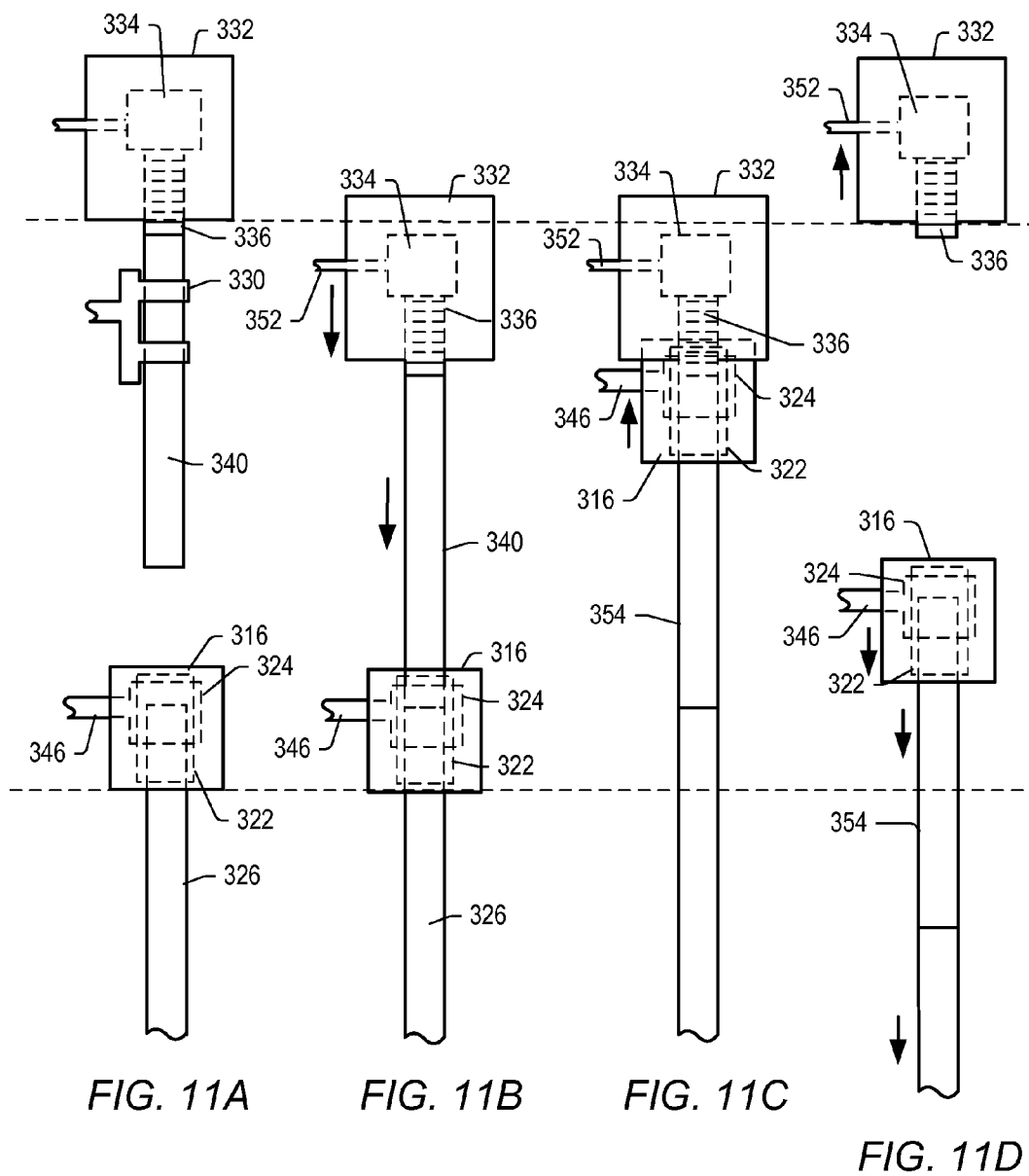

FIG. 10



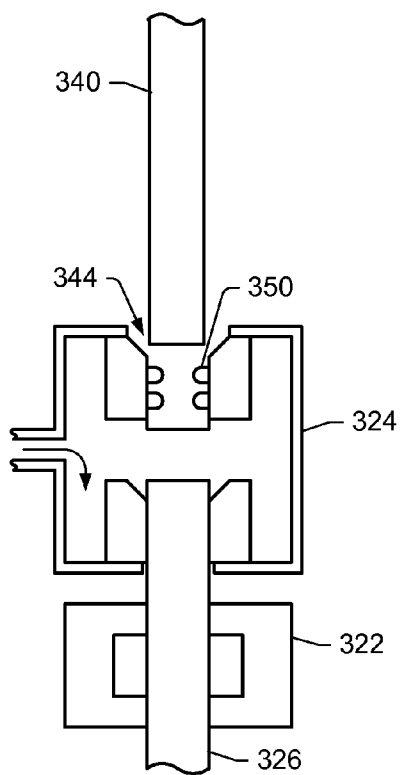

FIG. 12

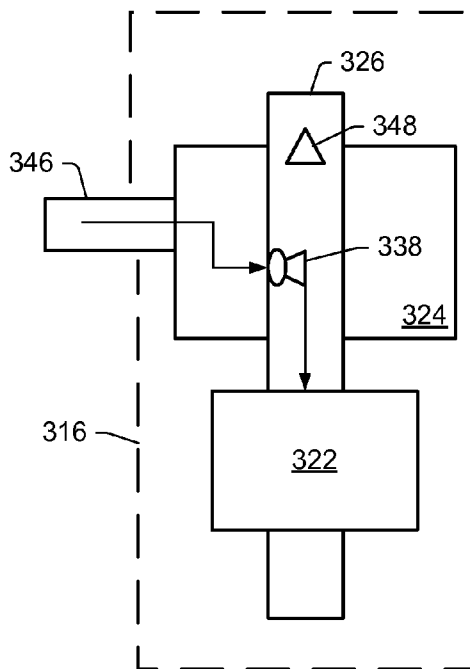

FIG. 13

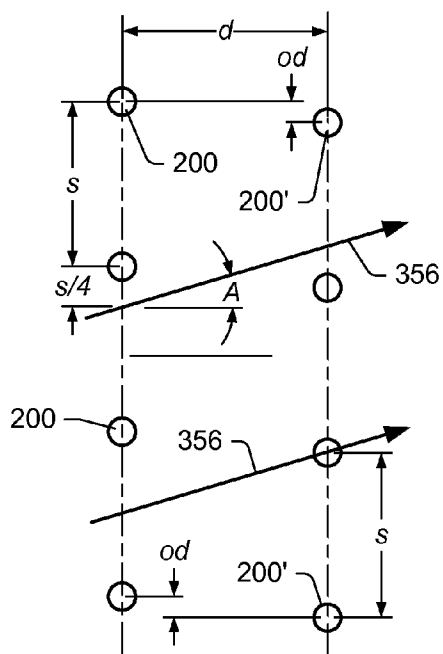

FIG. 14

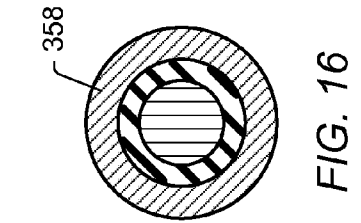
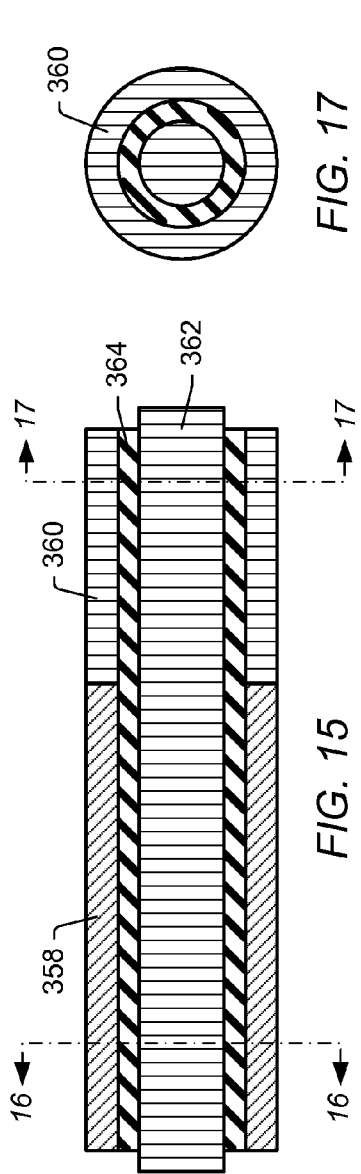

FIG. 17

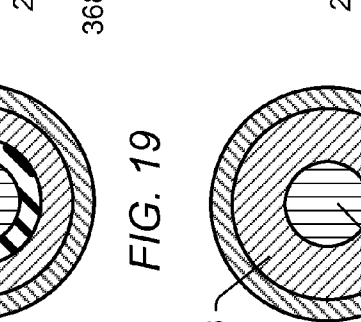
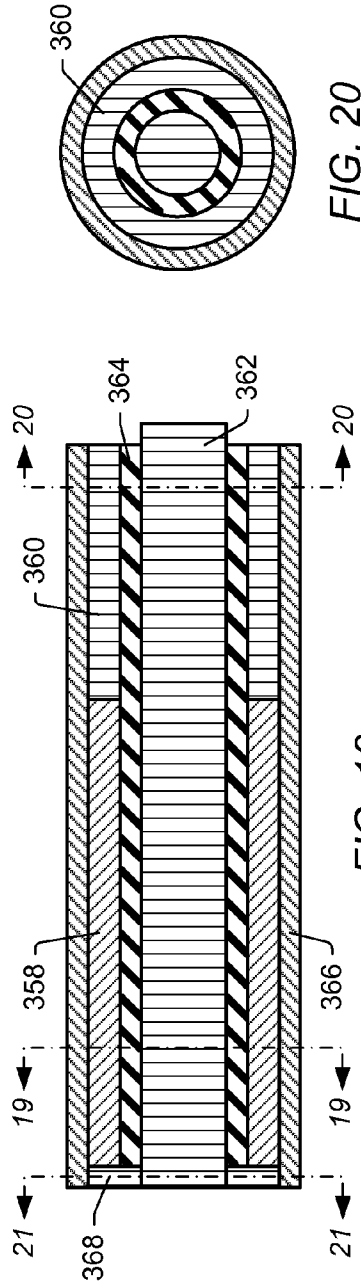
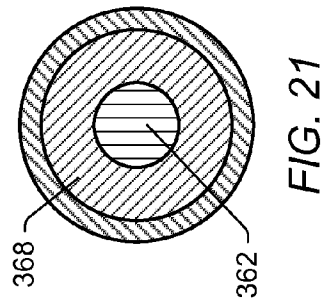

FIG. 20



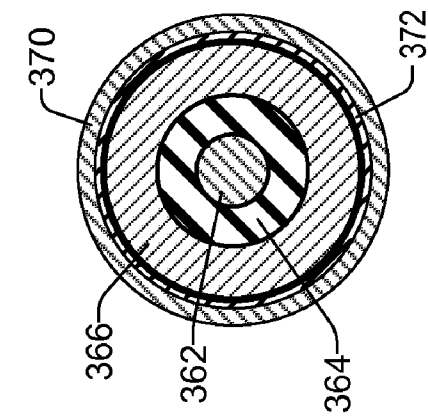

FIG. 22B

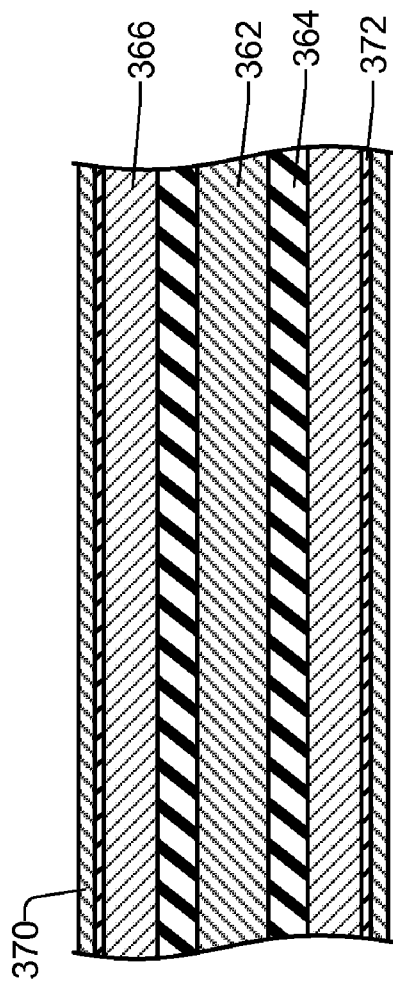

FIG. 22A

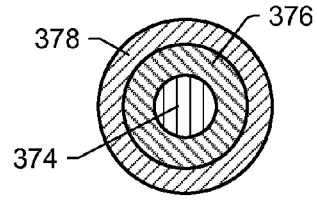
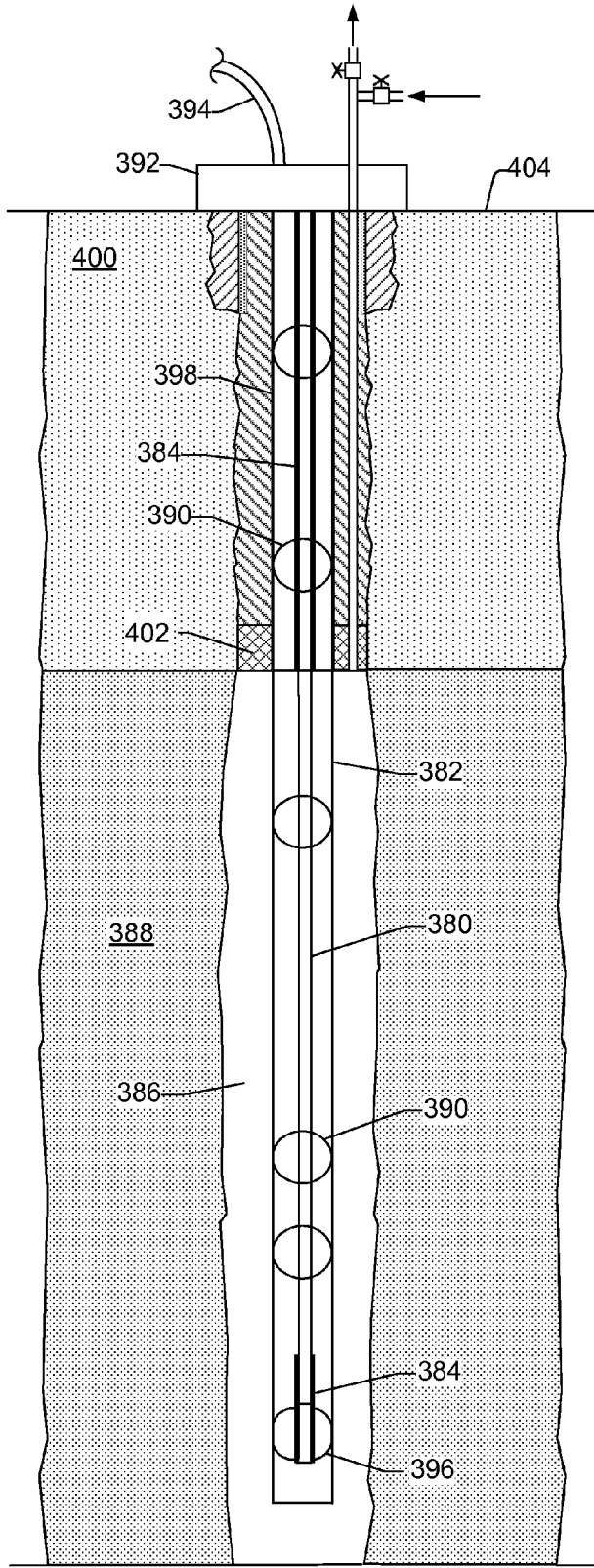

FIG. 23

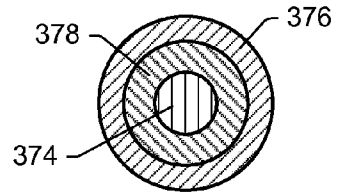

FIG. 24

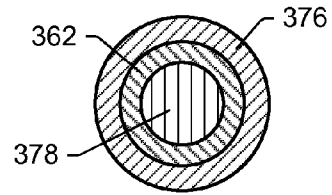

FIG. 25

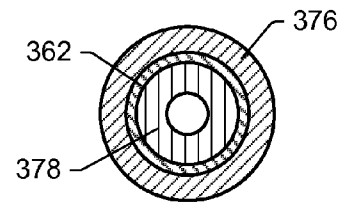

FIG. 26

FIG. 27

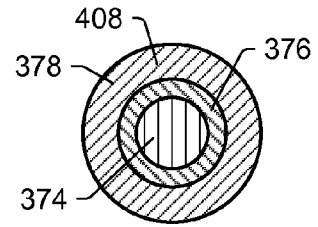
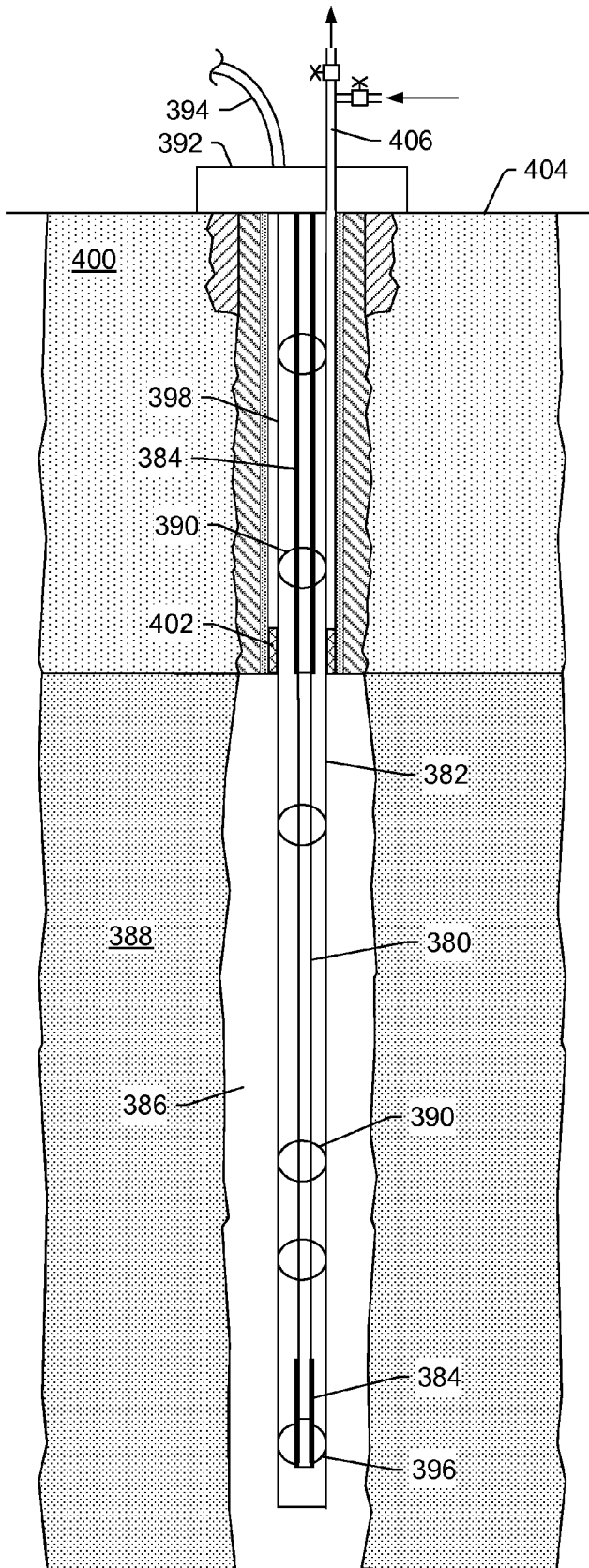

FIG. 29

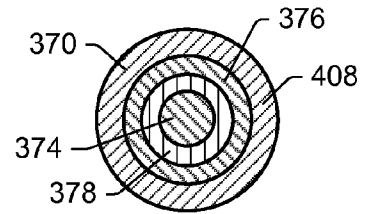

FIG. 30

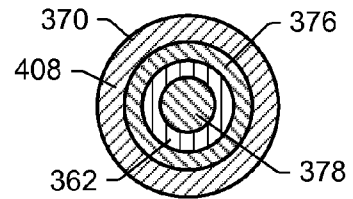

FIG. 31

FIG. 28

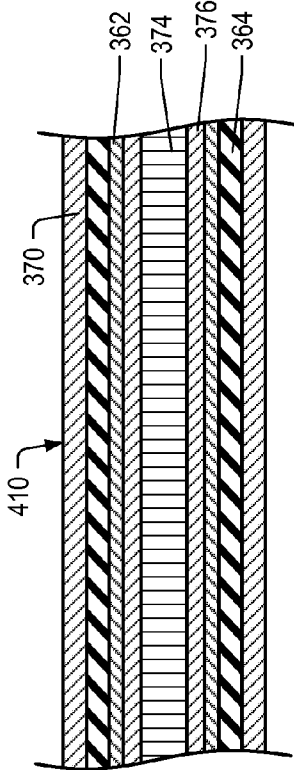

FIG. 32A

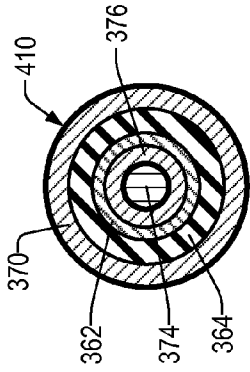

FIG. 32B

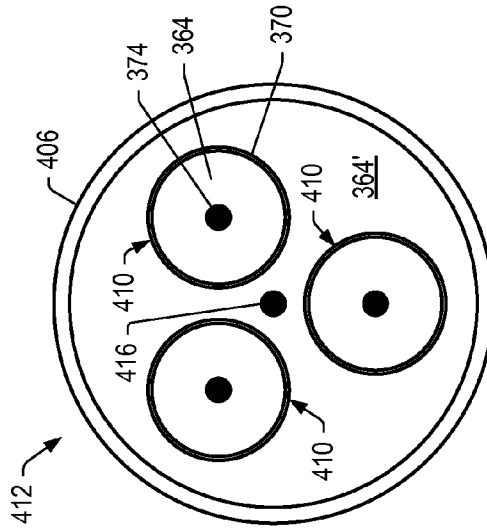

FIG. 33

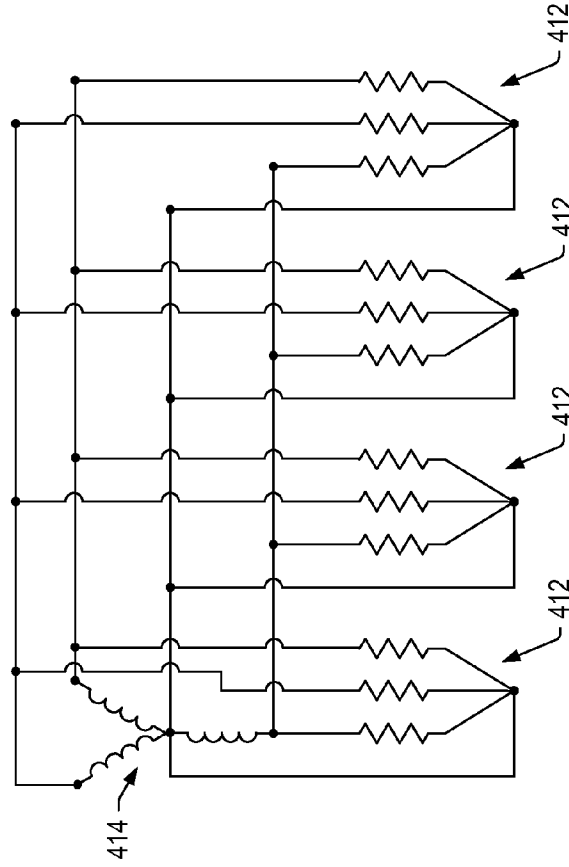

FIG. 34

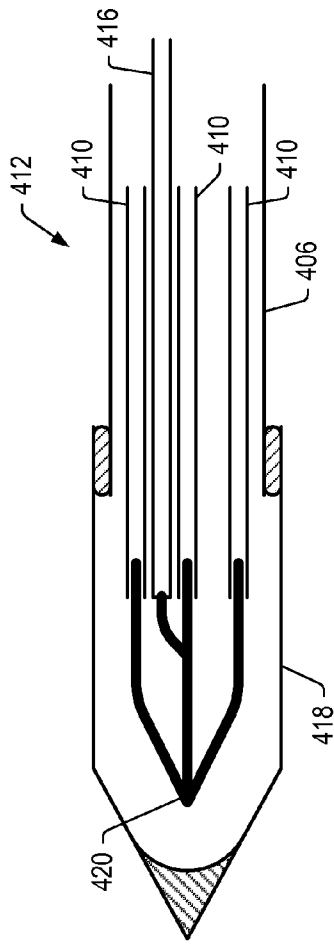

FIG. 35

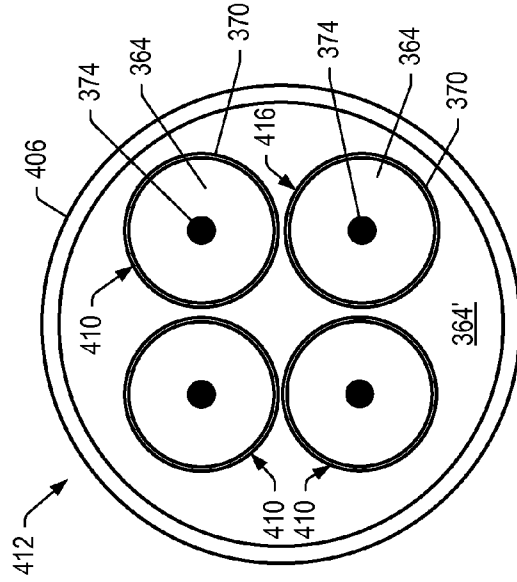

FIG. 37

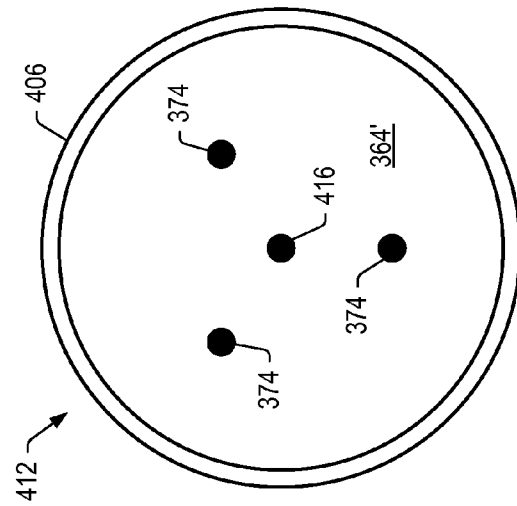

FIG. 36

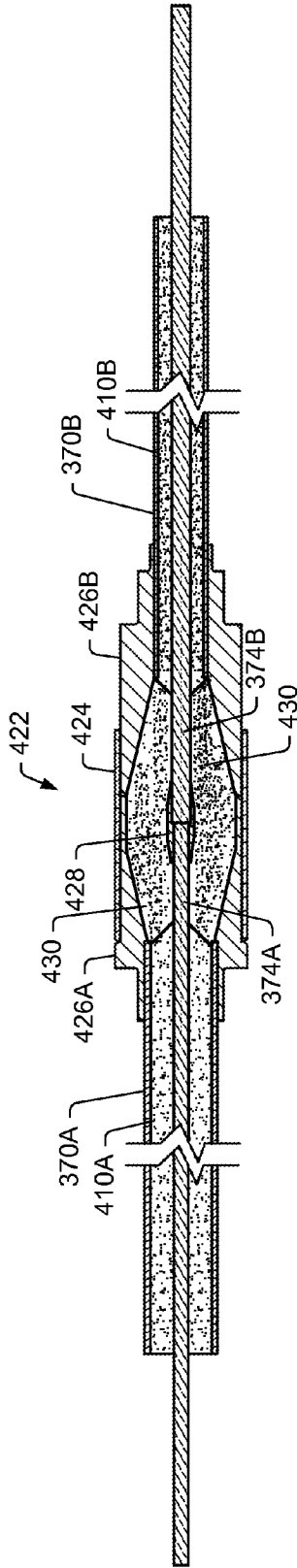

FIG. 38

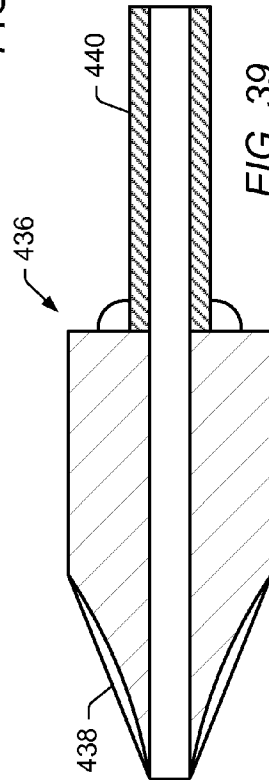

FIG. 39

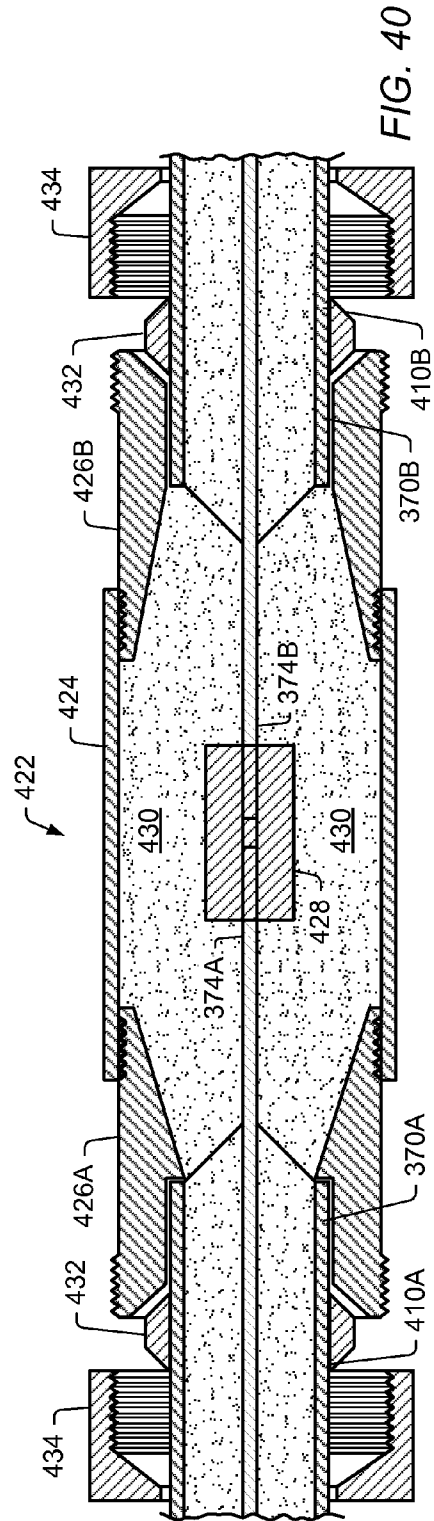

FIG. 40

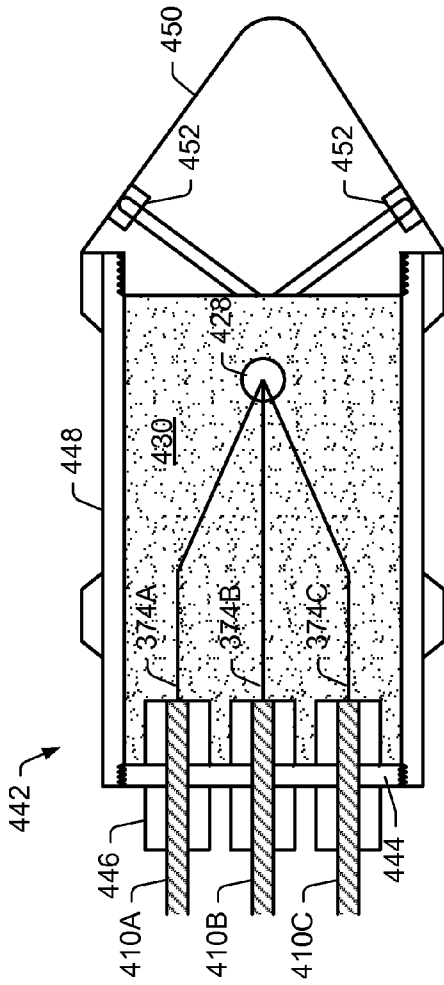

FIG. 41A

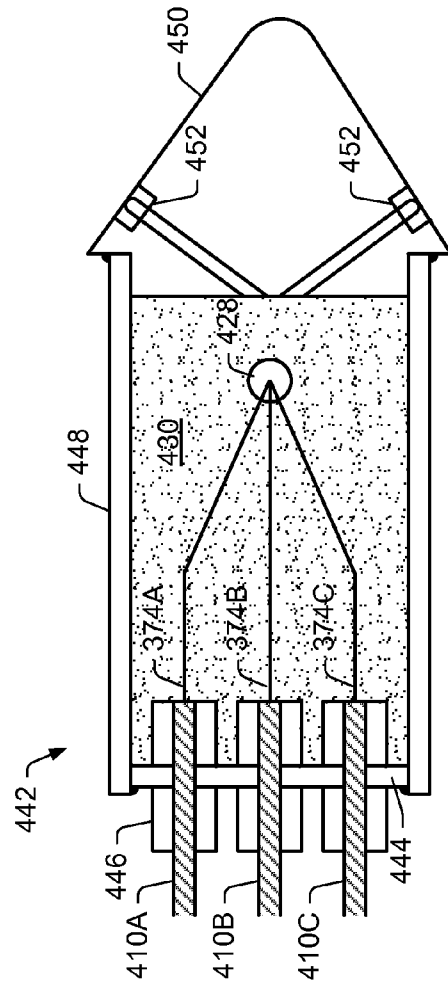

FIG. 41B

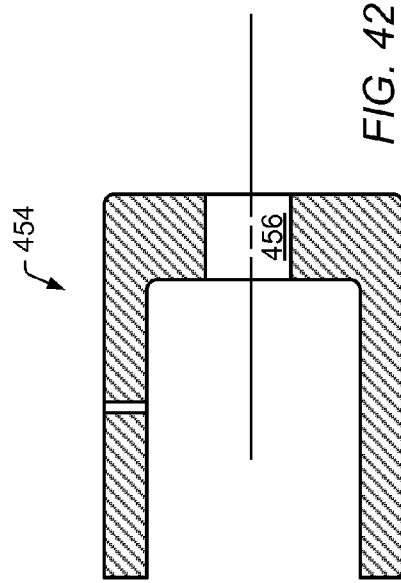

FIG. 42

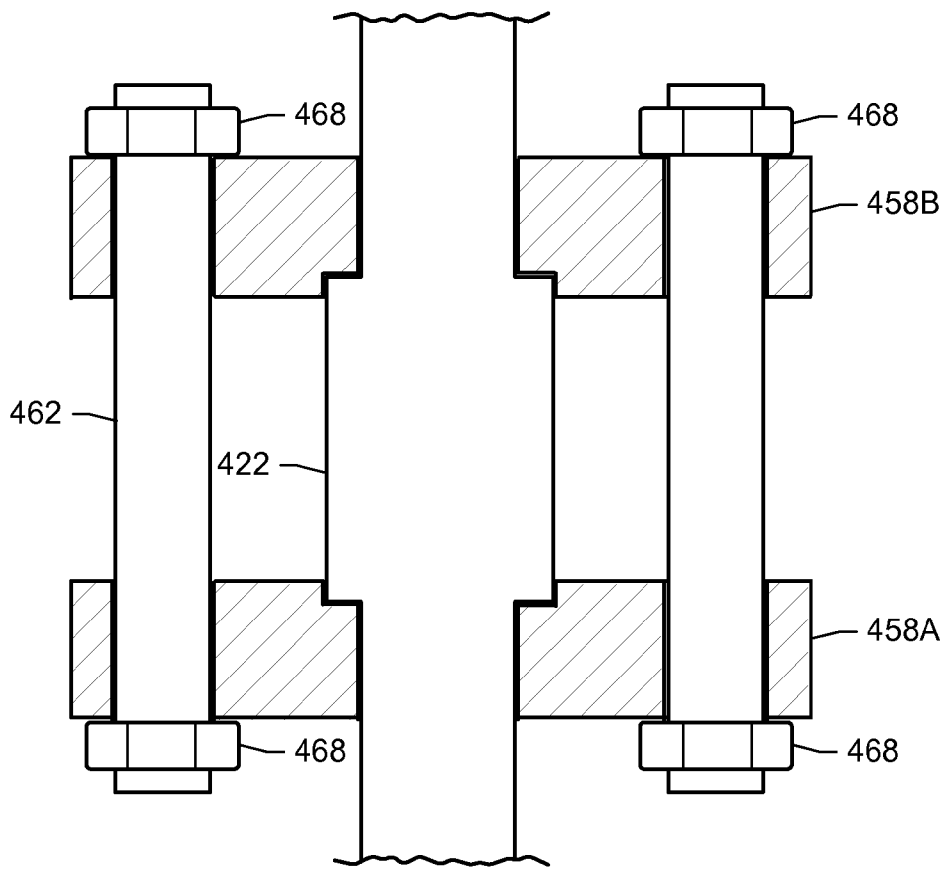

FIG. 43

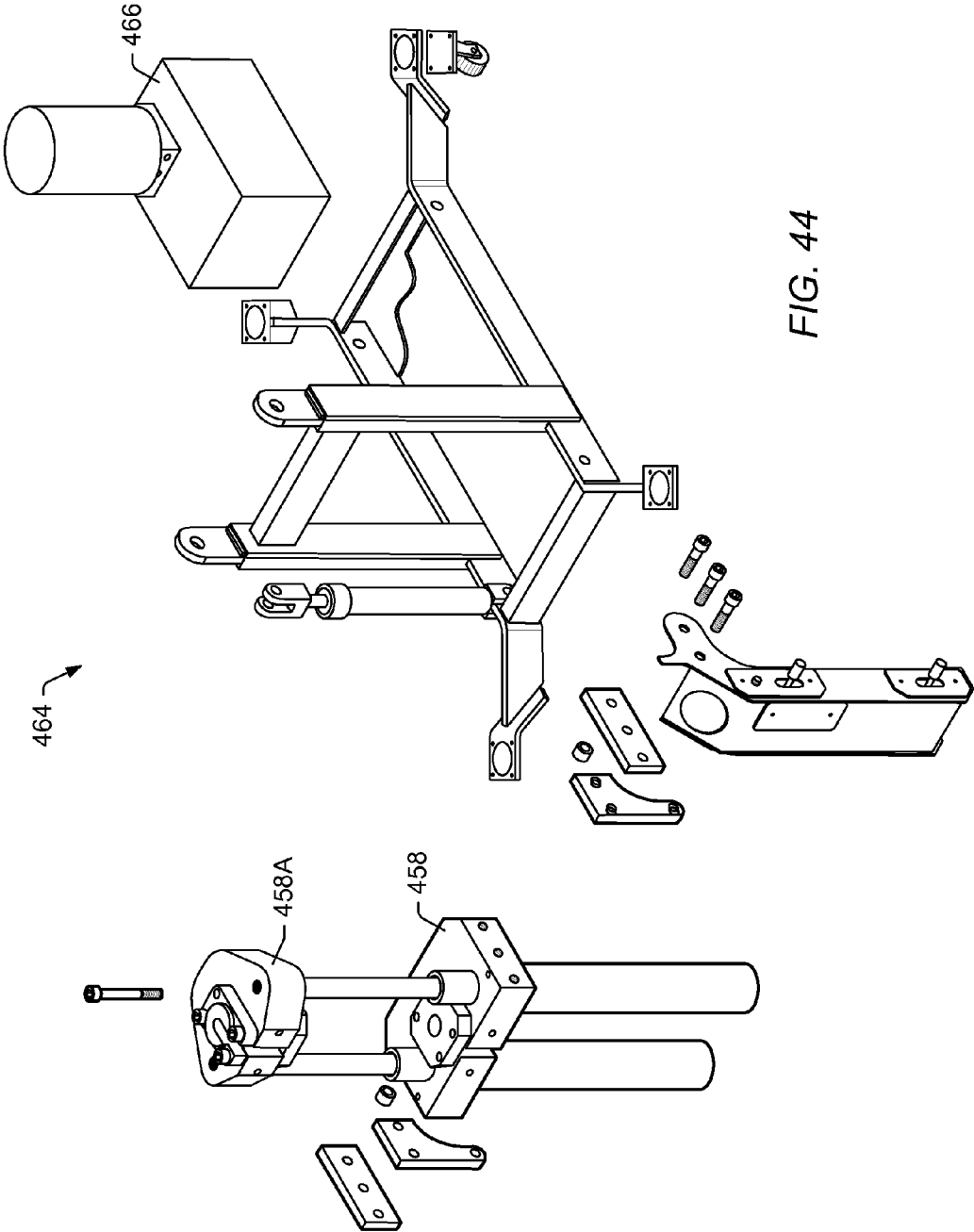

FIG. 44

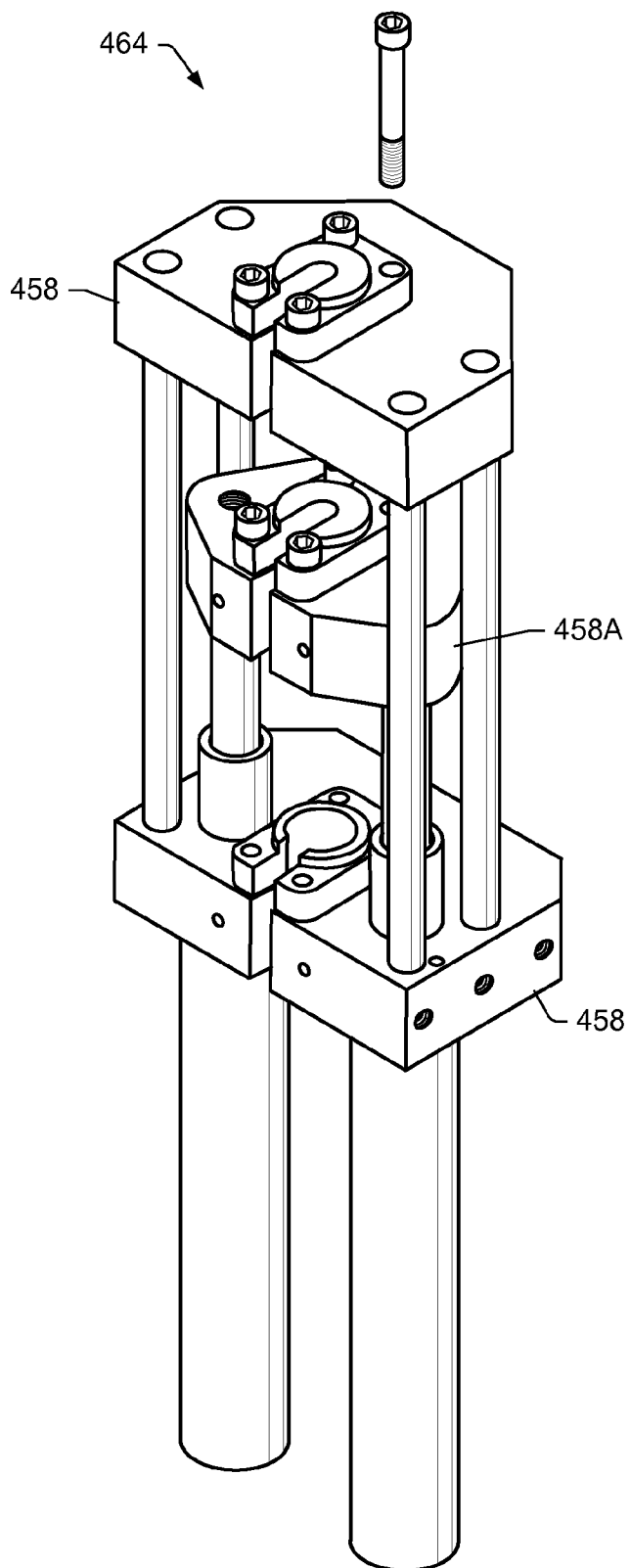

FIG. 45

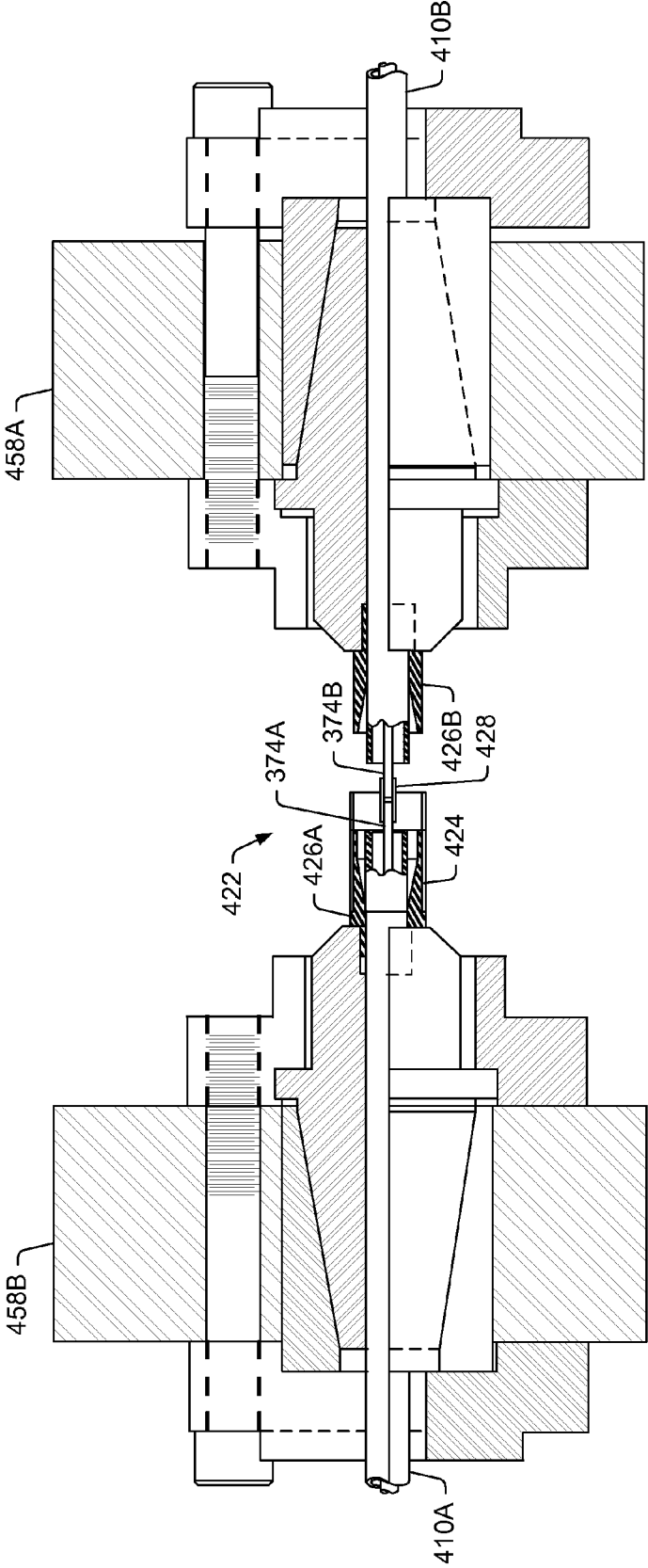

FIG. 46

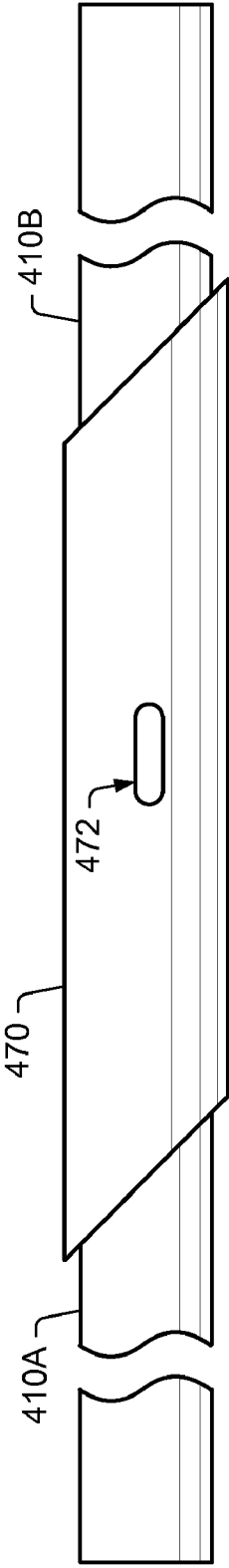

FIG. 47

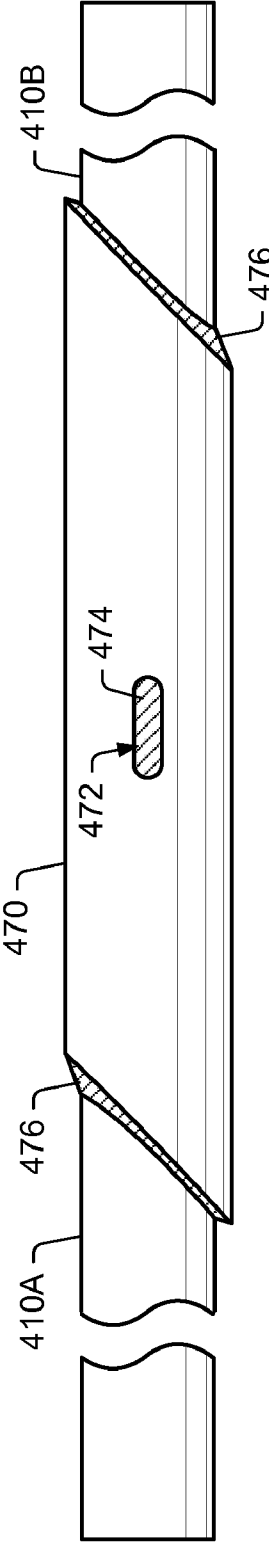

FIG. 48

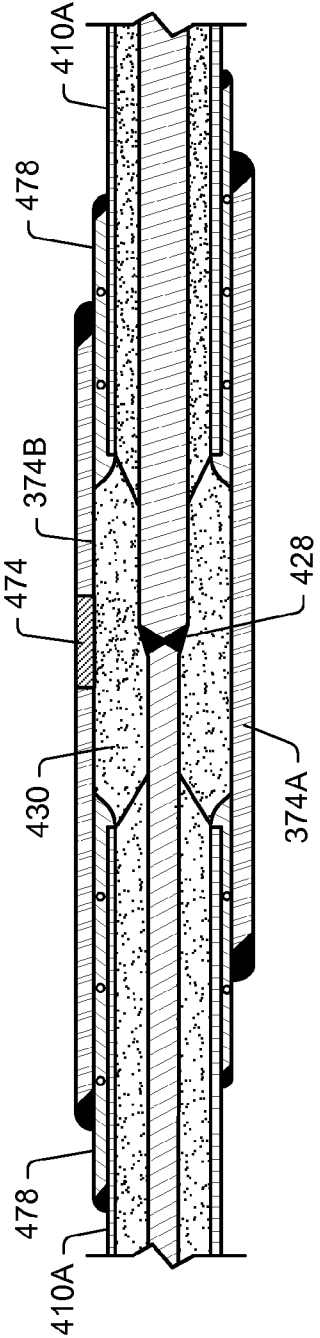

FIG. 49

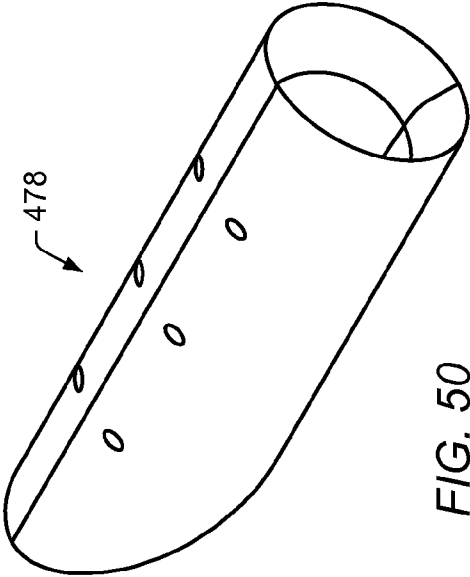

FIG. 50

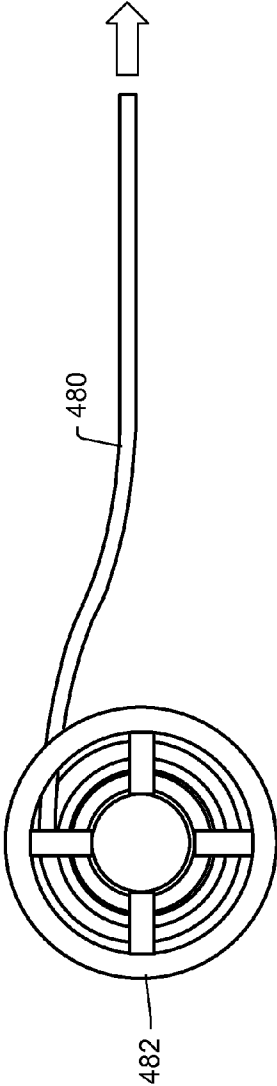

FIG. 51

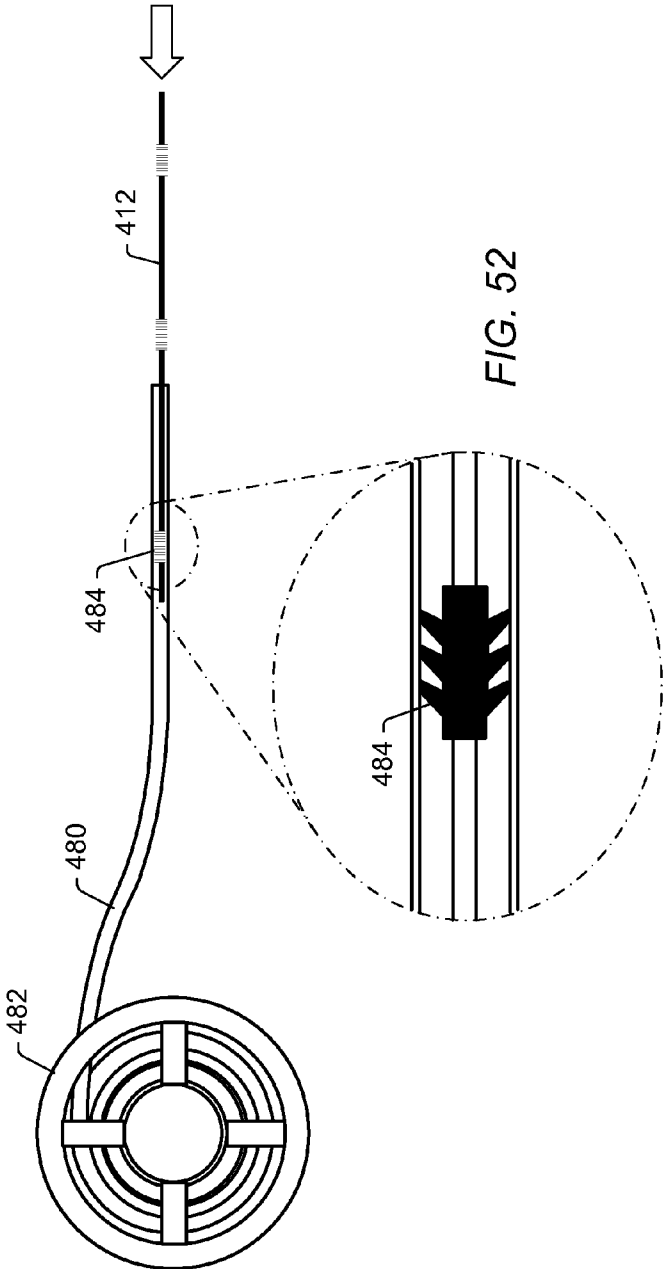

FIG. 52

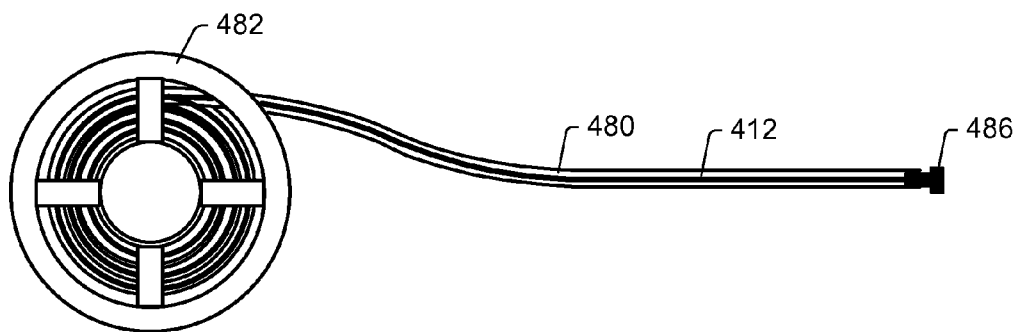

FIG. 53

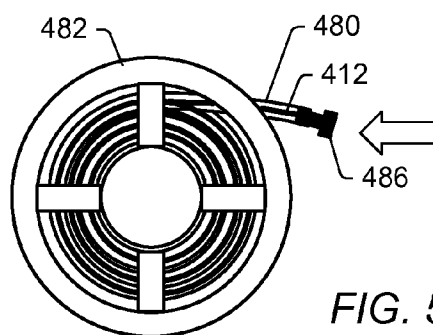

FIG. 54

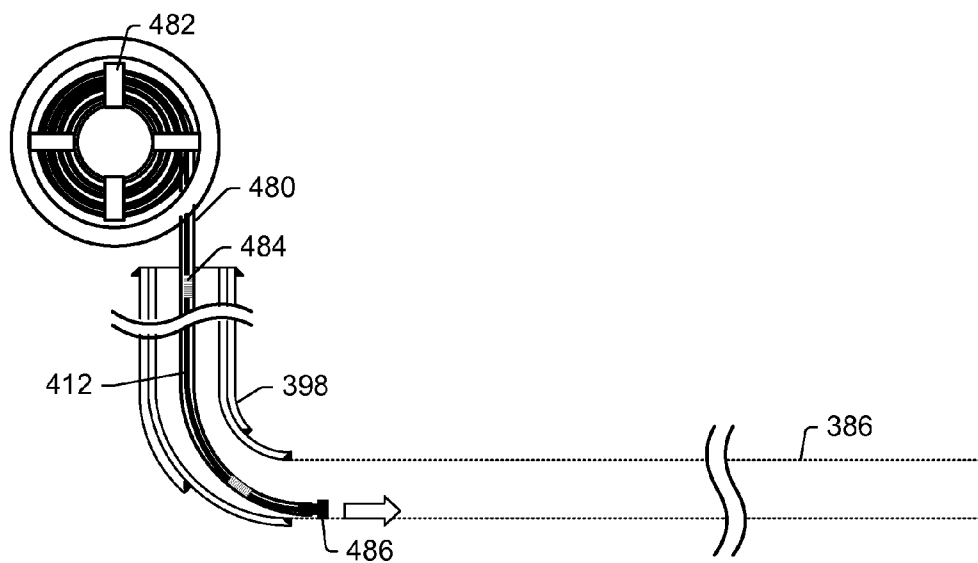

FIG. 55

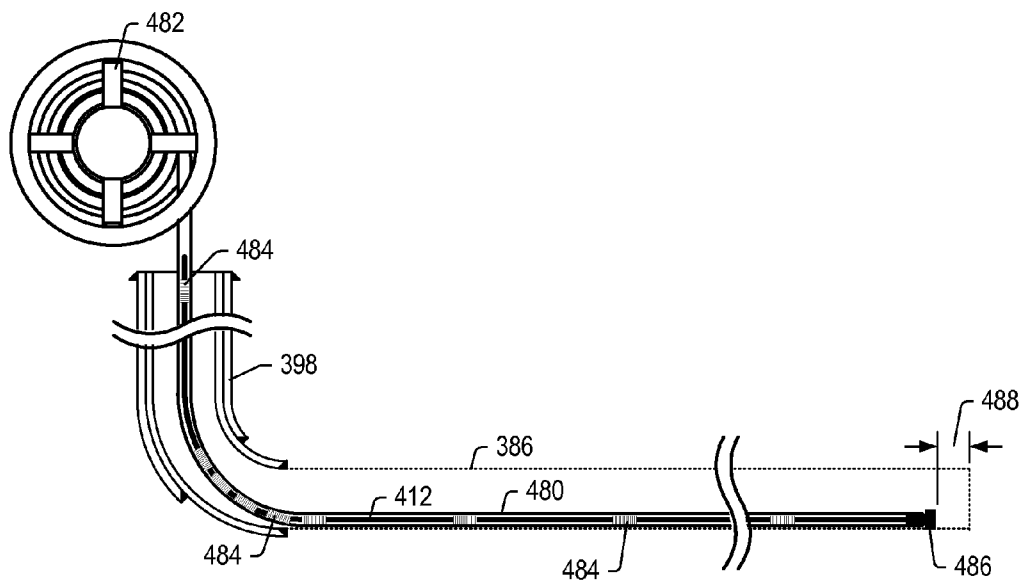

FIG. 56

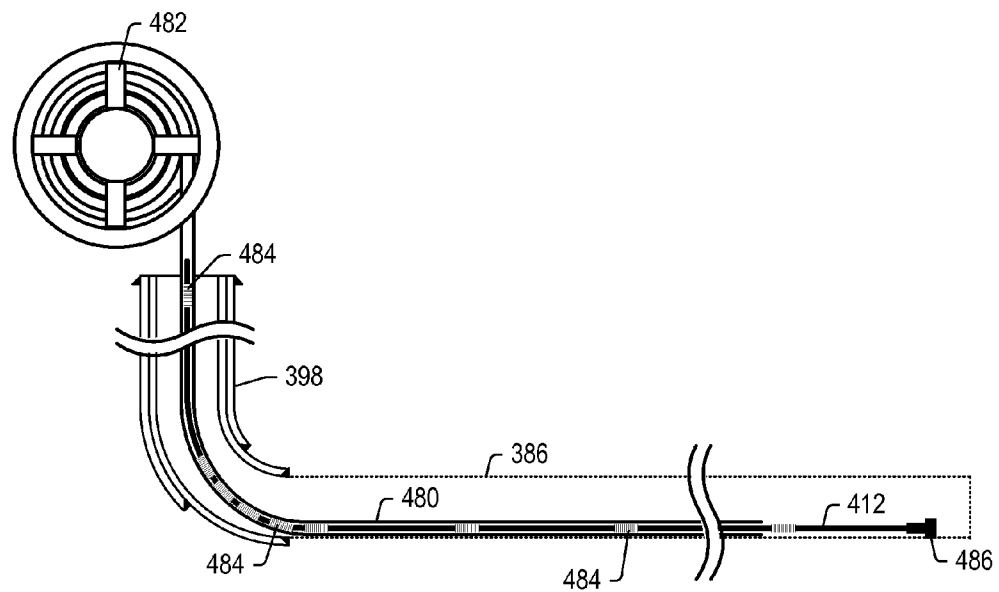

FIG. 57

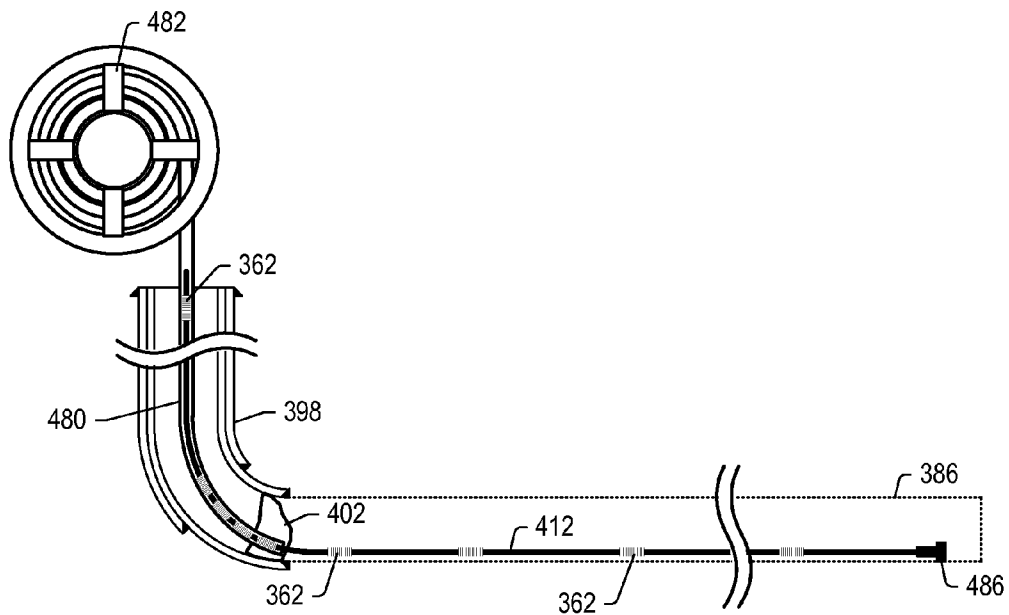

FIG. 58

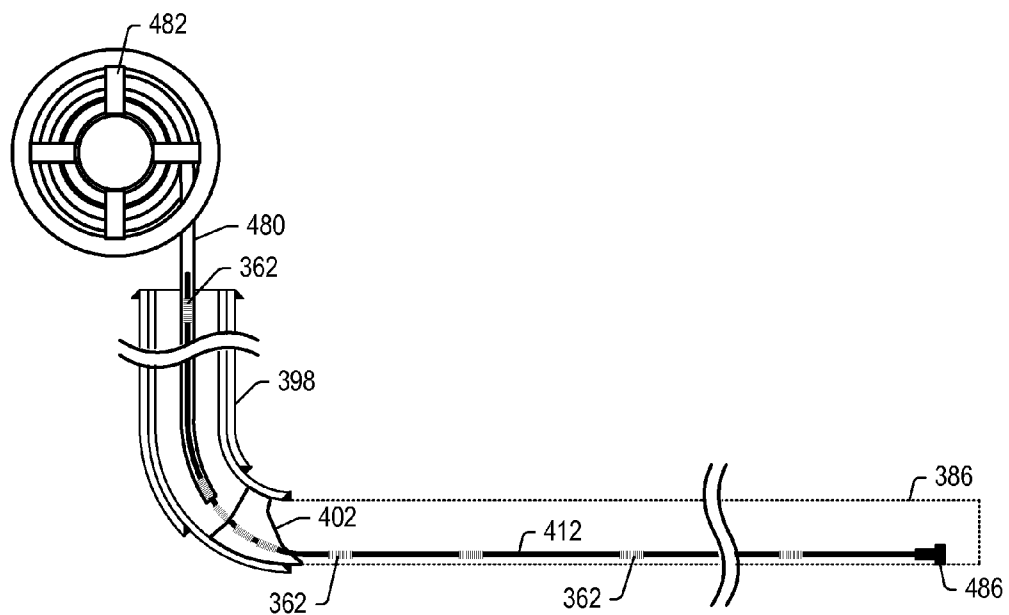

FIG. 59

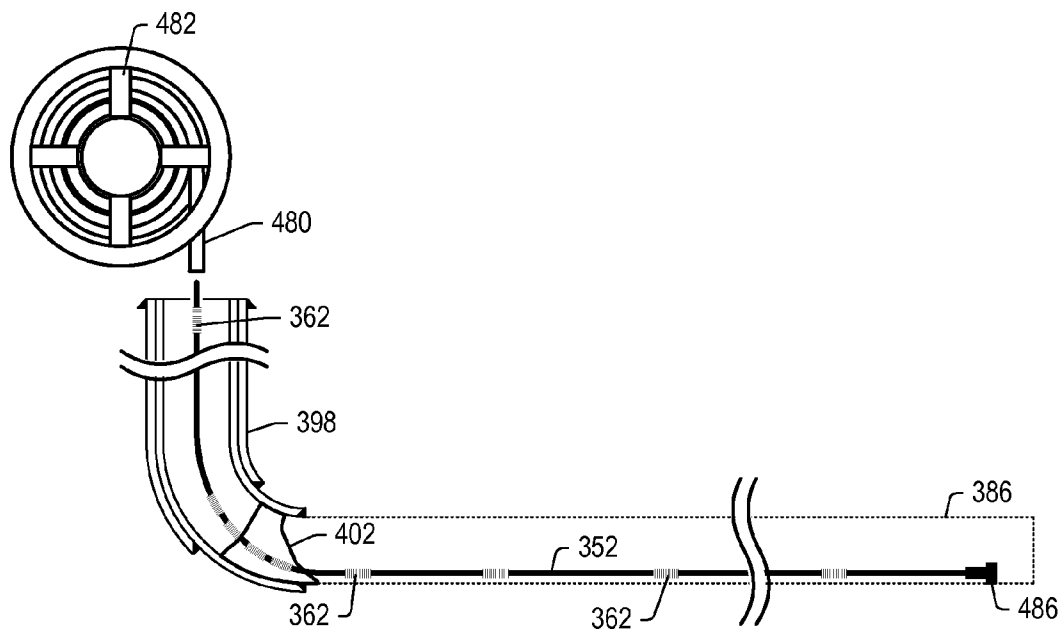

FIG. 60

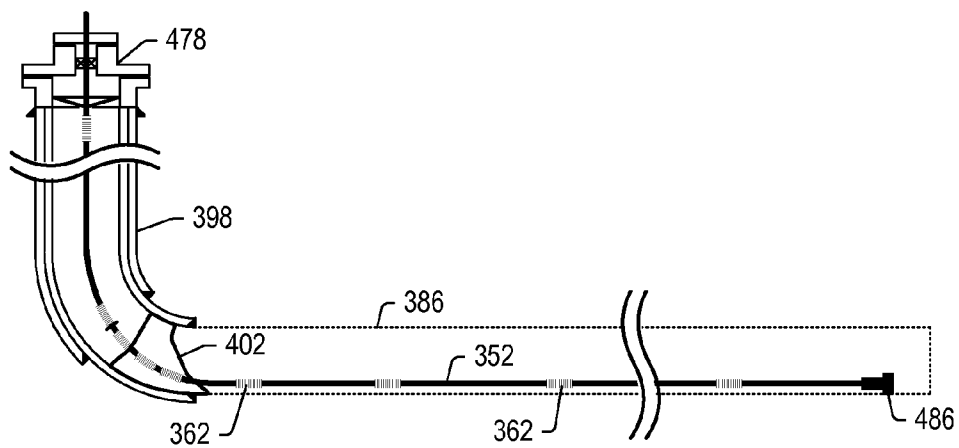

FIG. 61

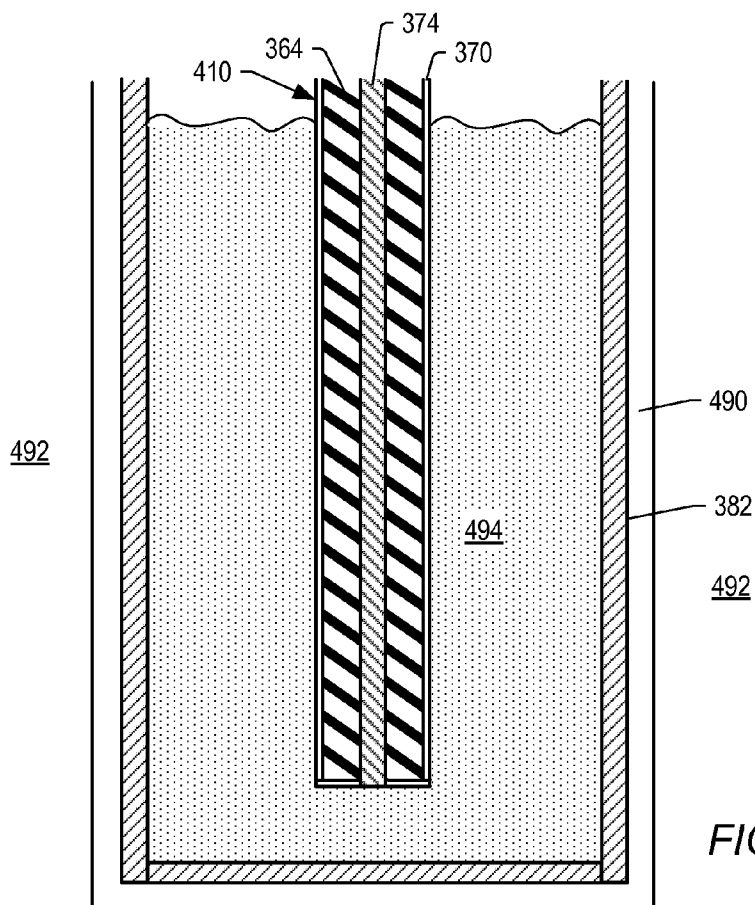

FIG. 62

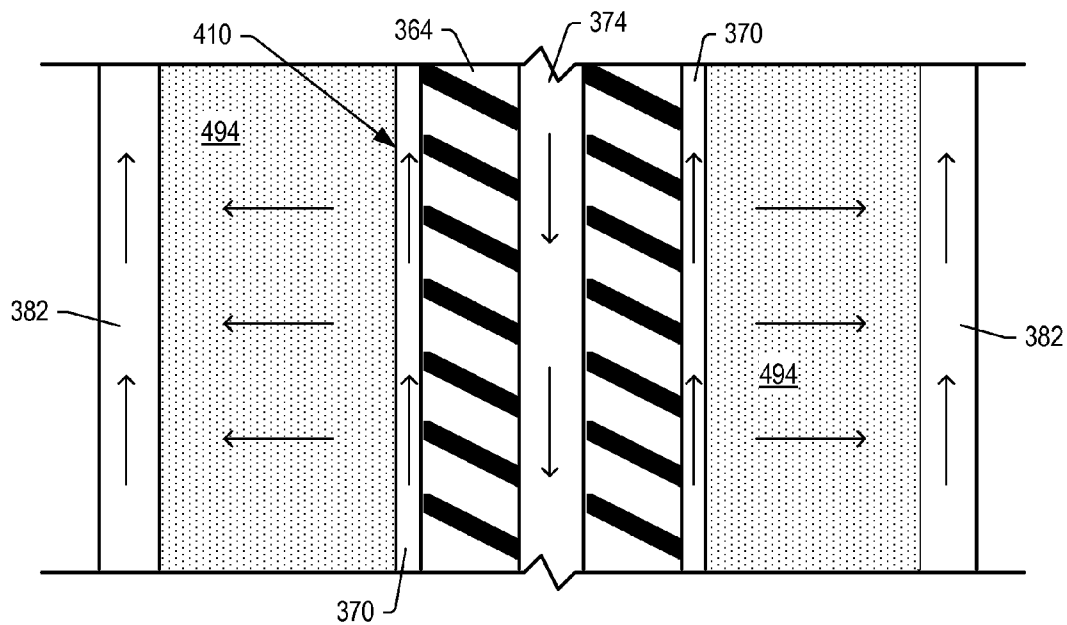

FIG. 63

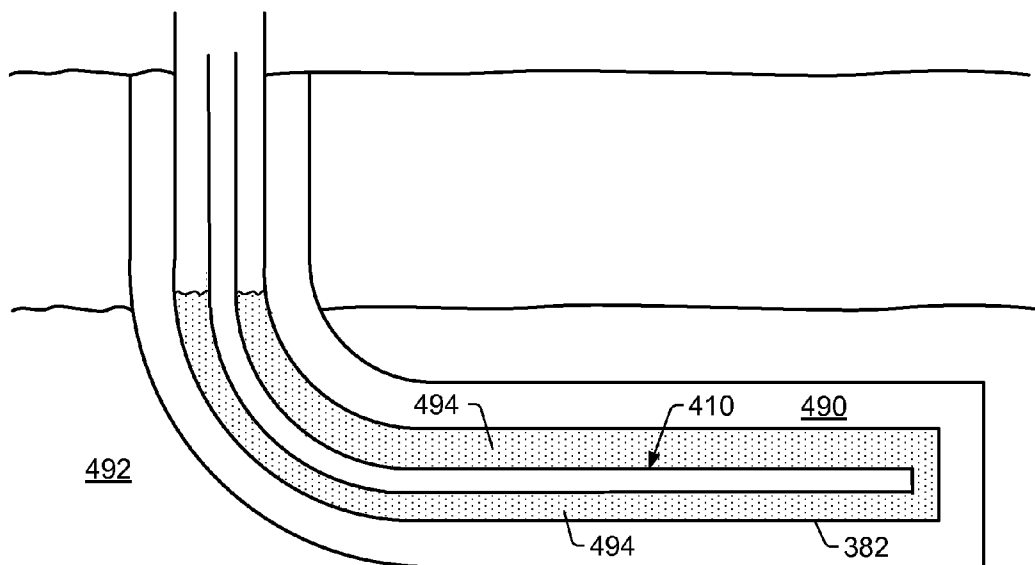

FIG. 64

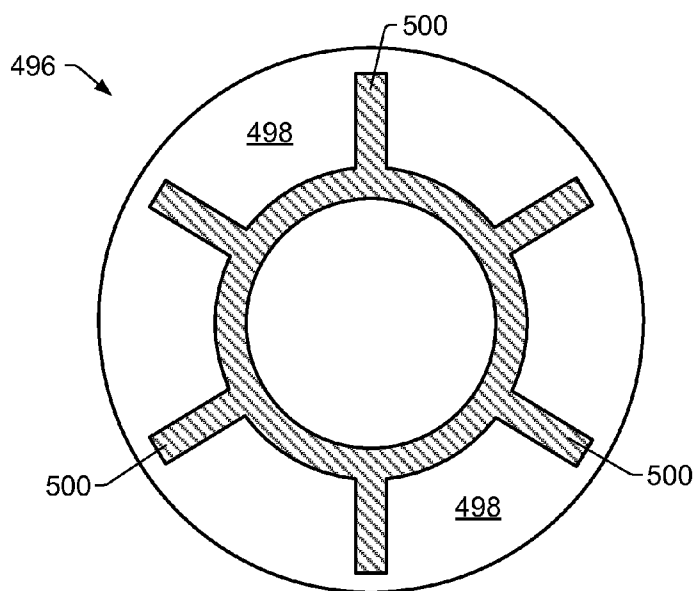

FIG. 65

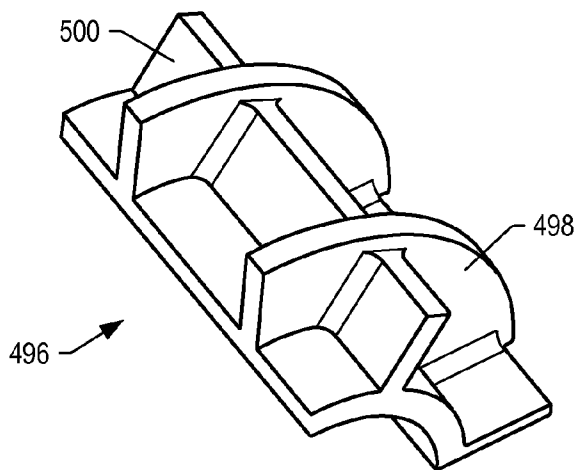

FIG. 66

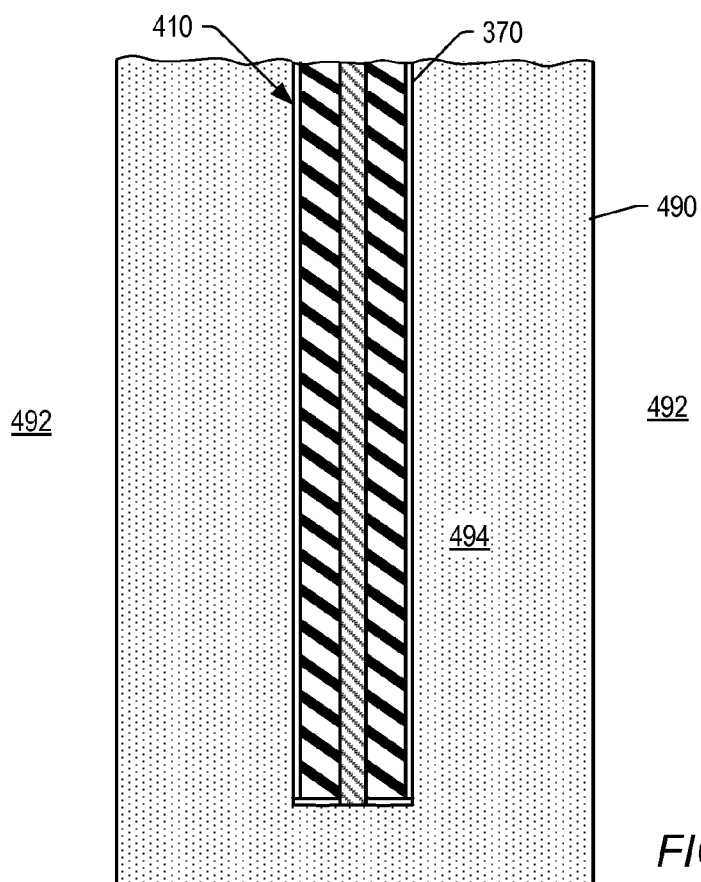

FIG. 67

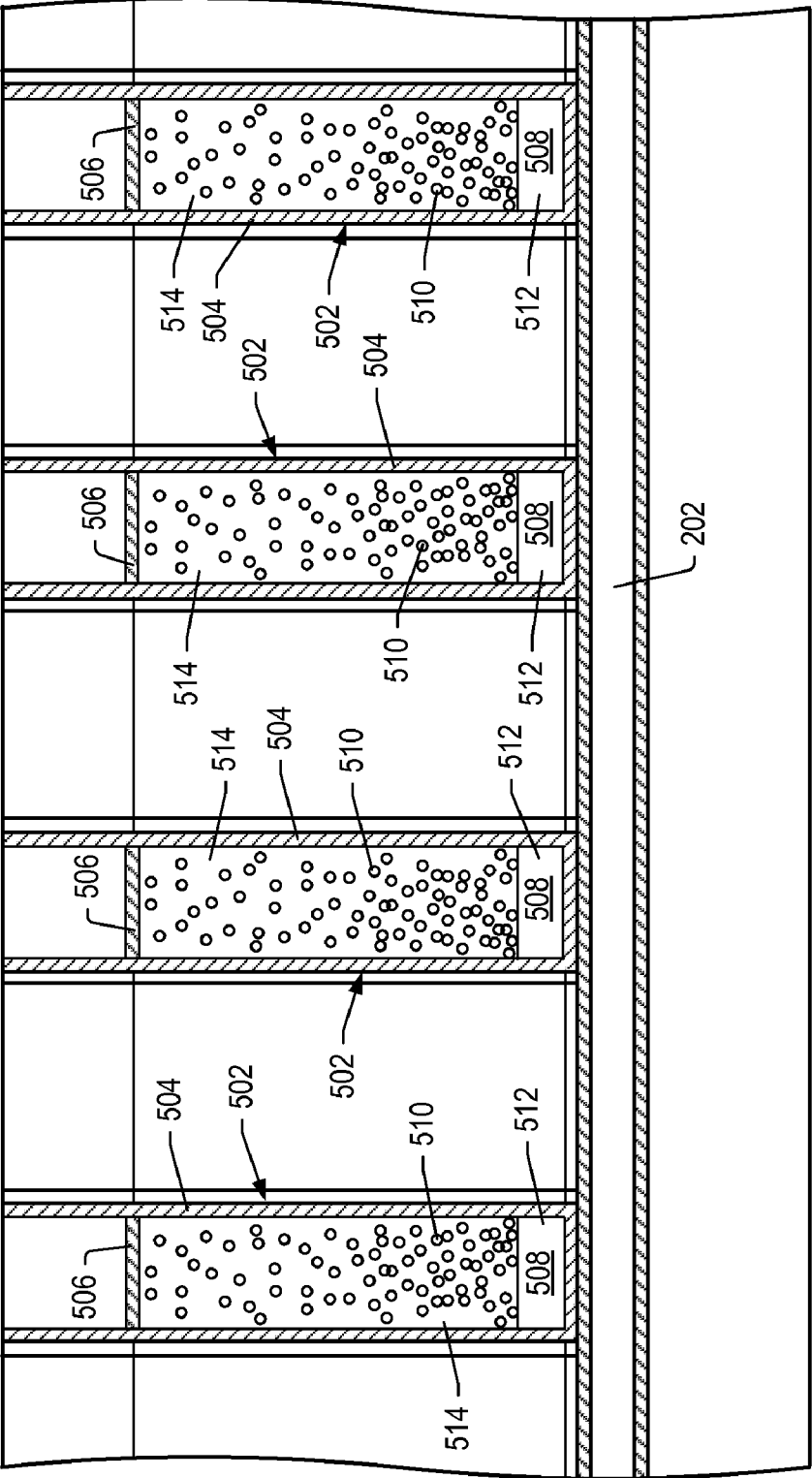

FIG. 68

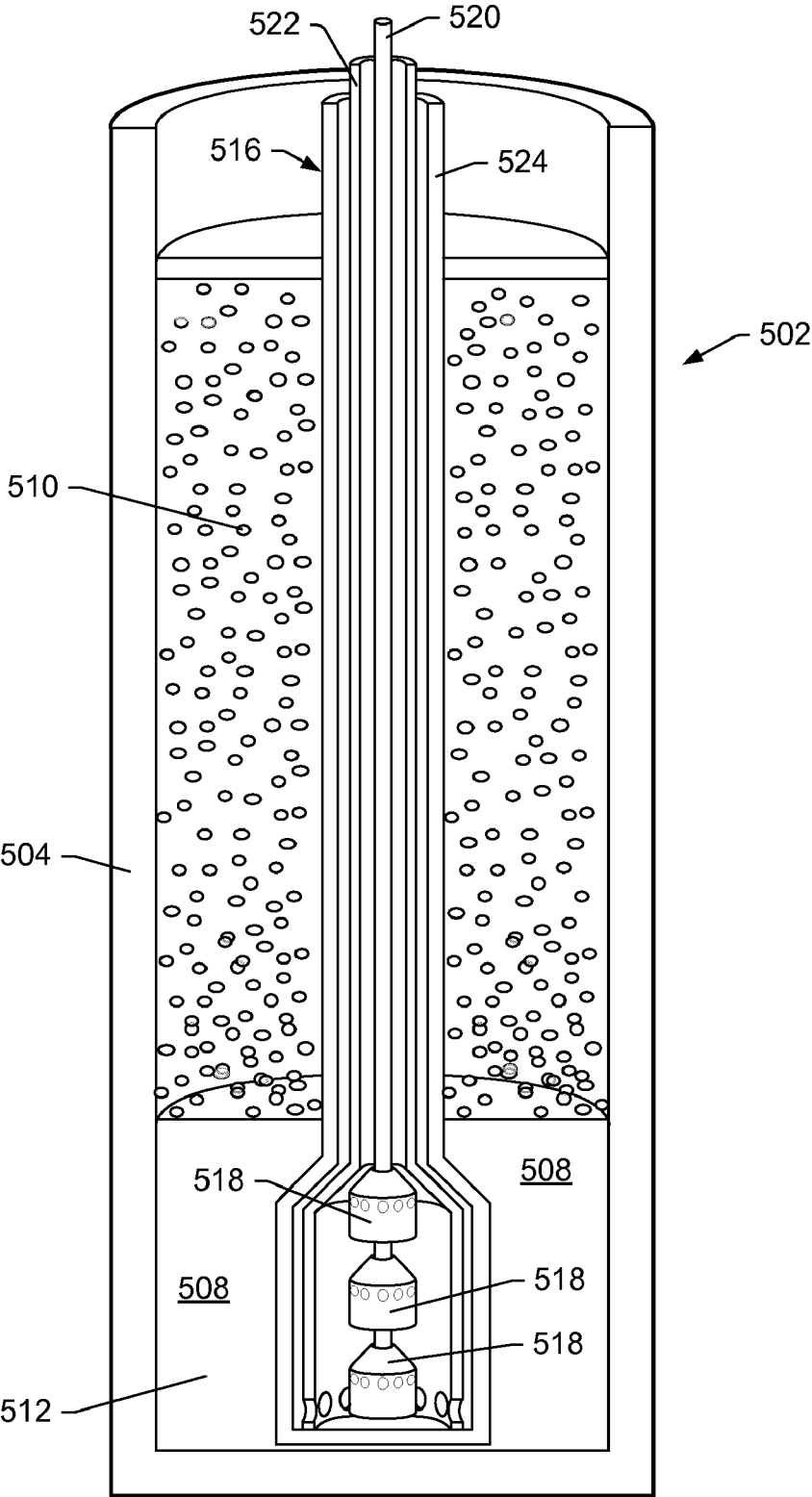

FIG. 69

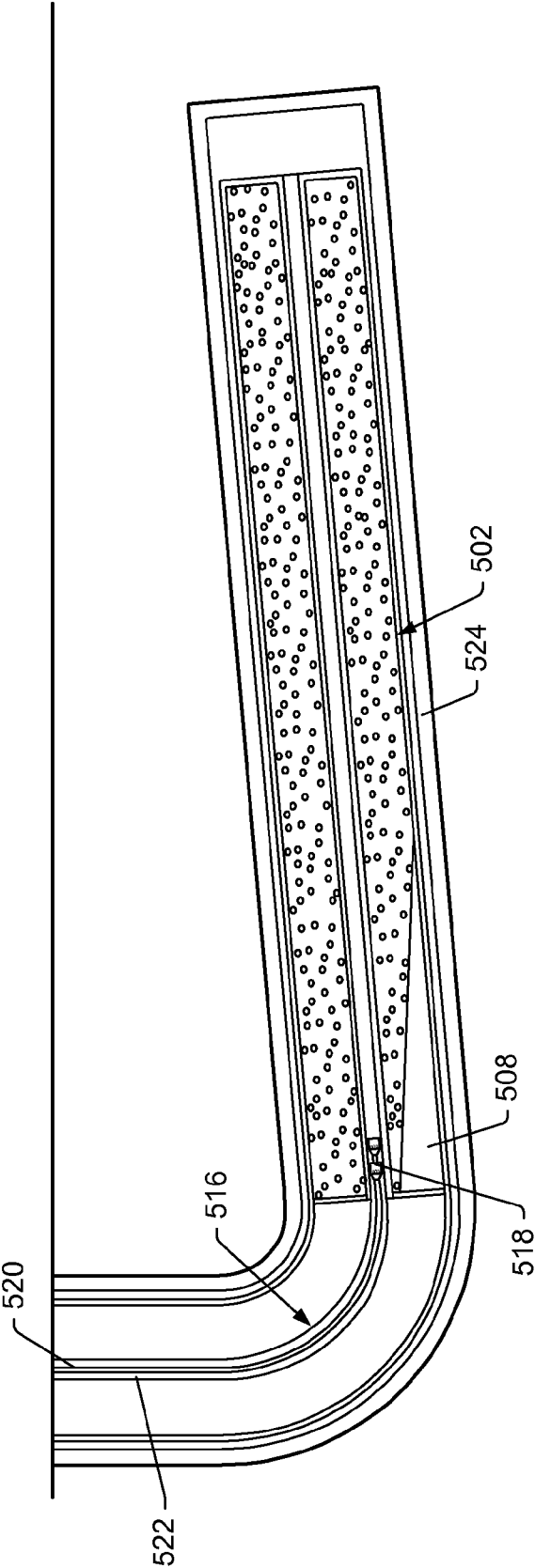

FIG. 70

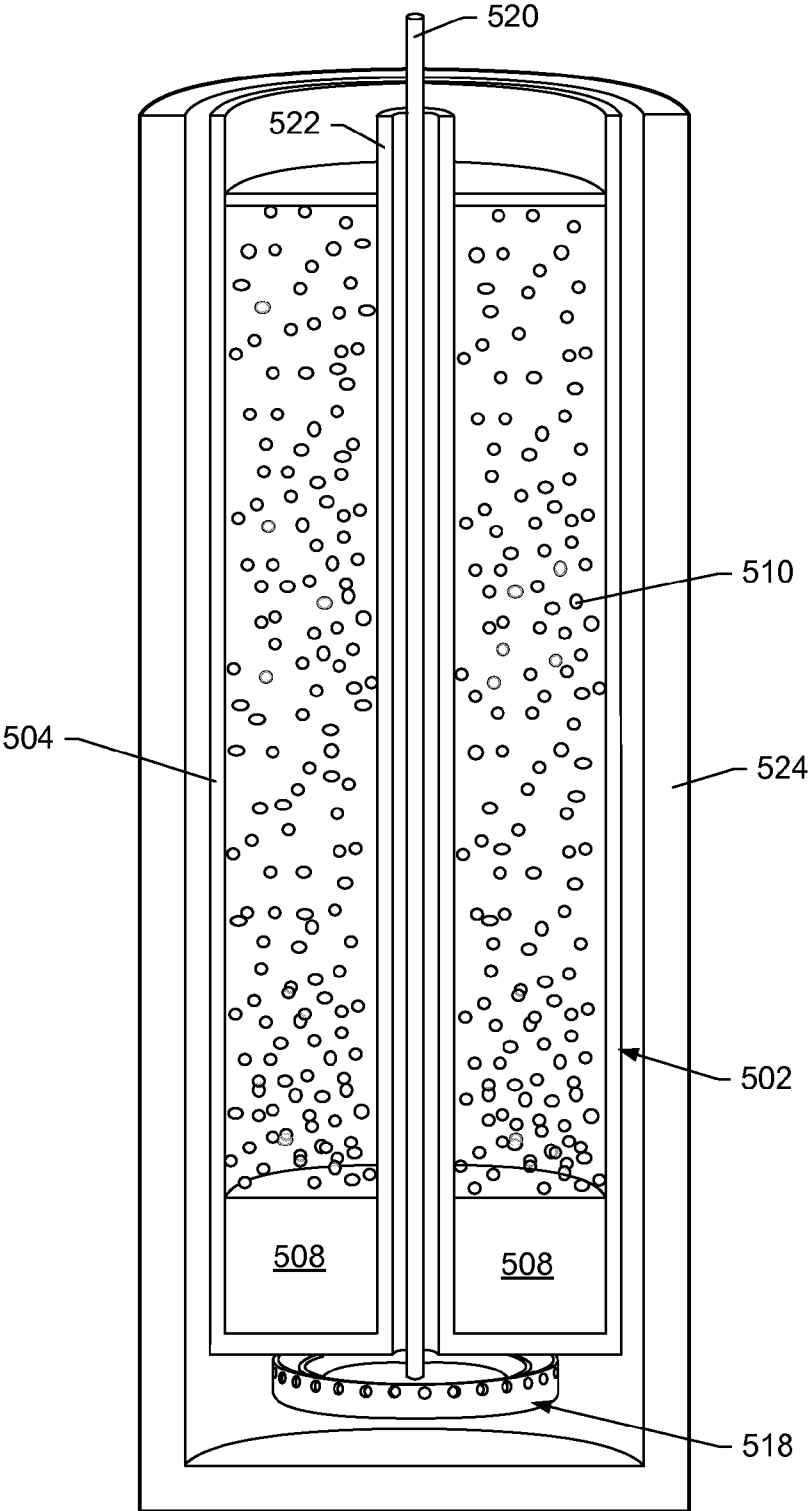

FIG. 71

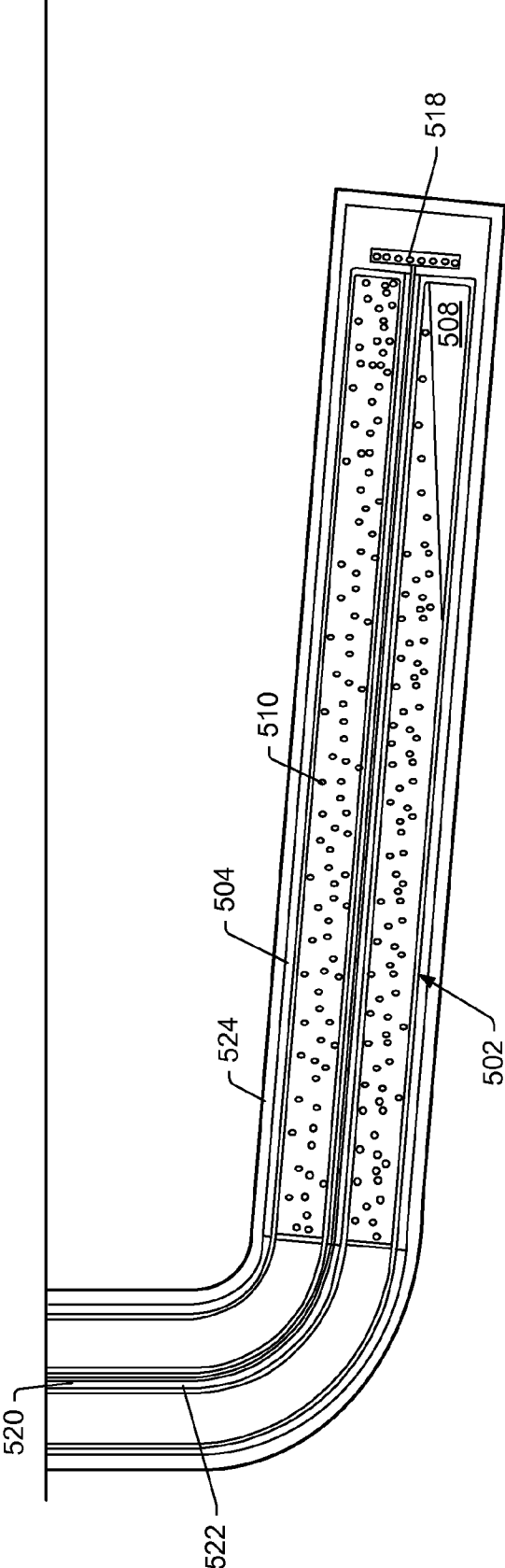

FIG. 72

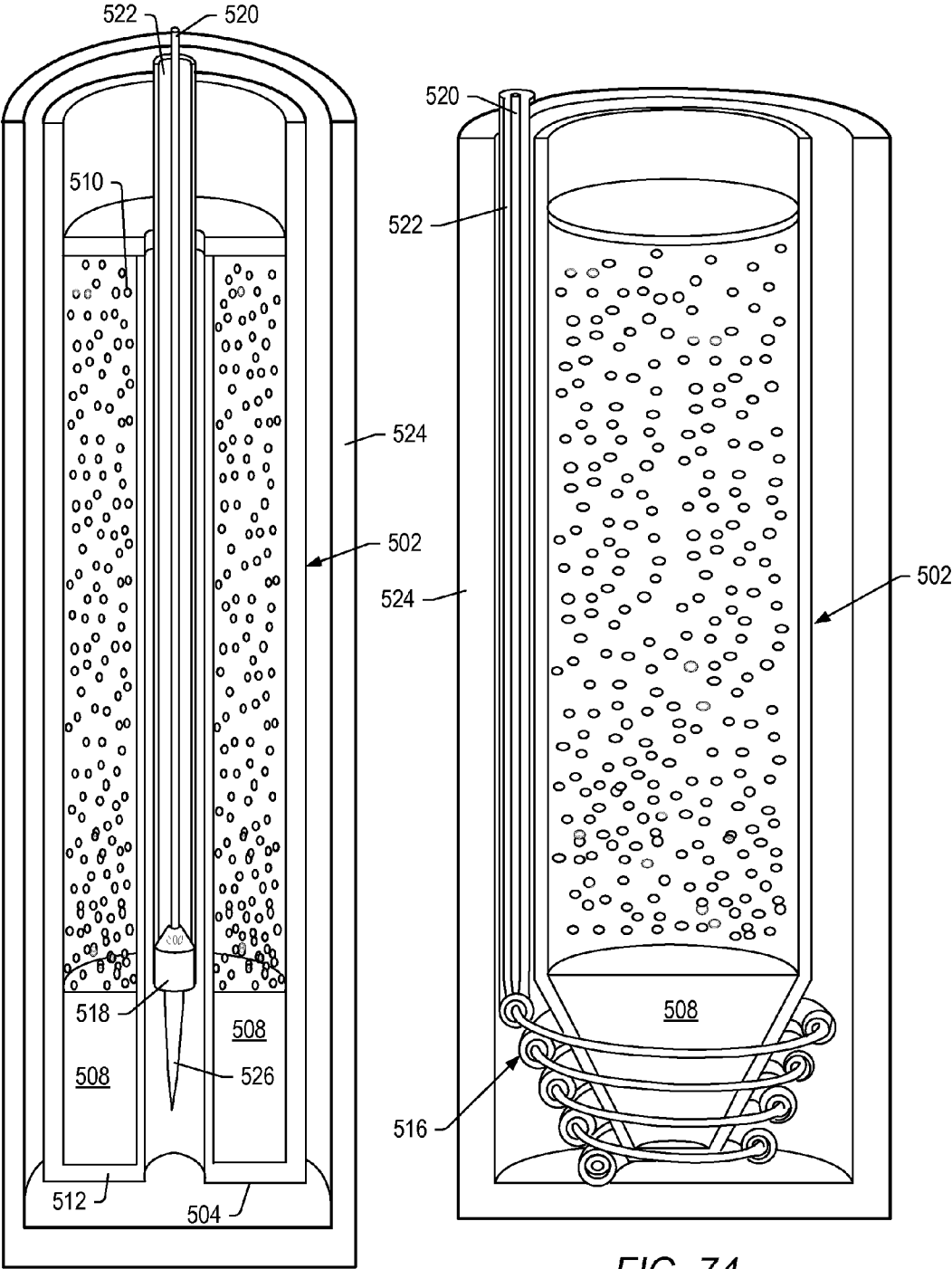

FIG. 73

FIG. 74

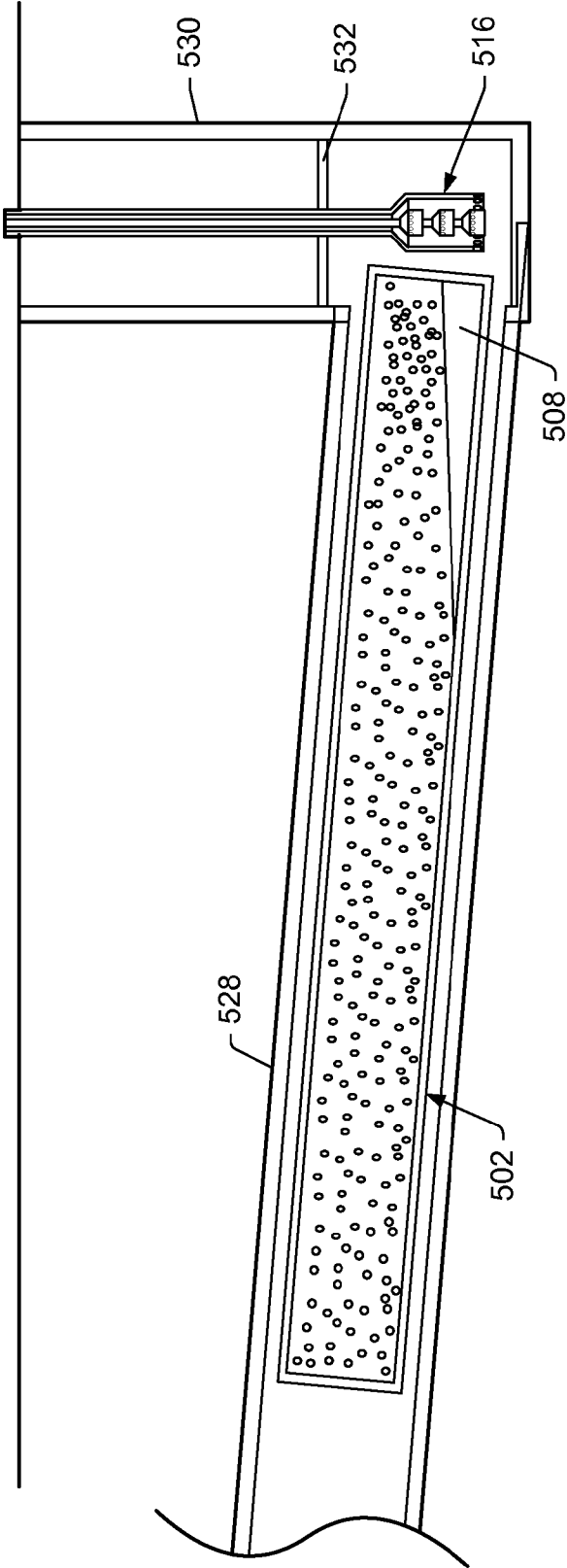

FIG. 75

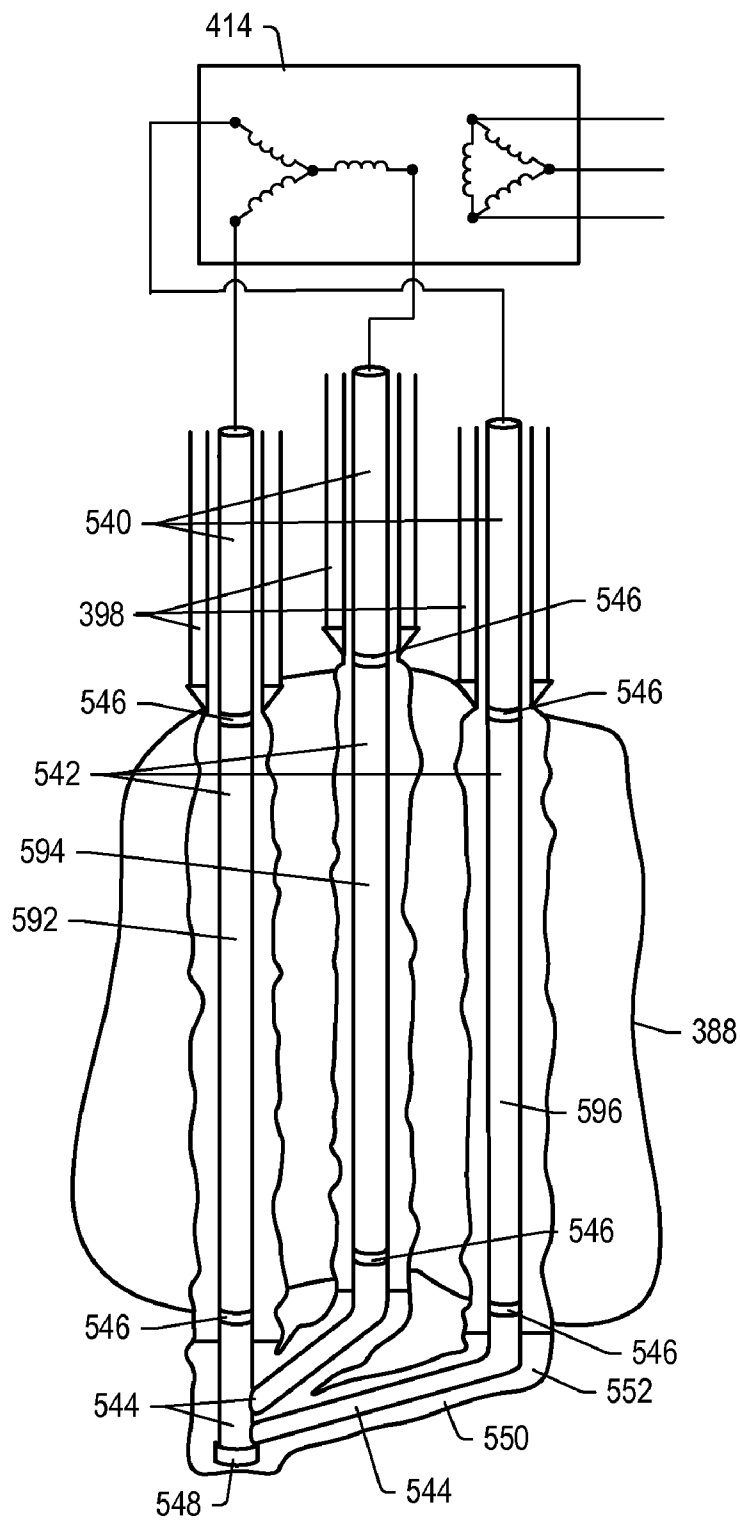

FIG. 76

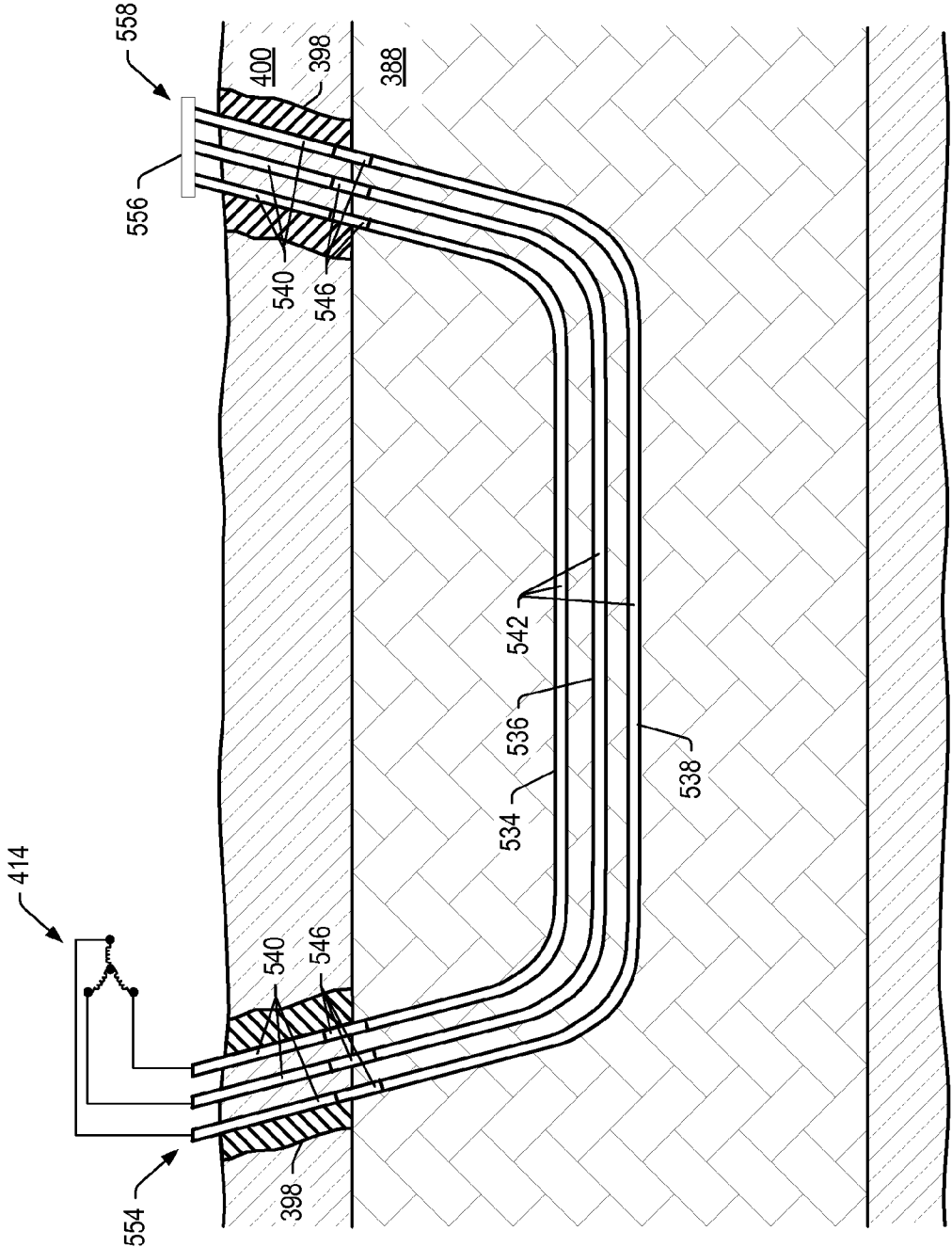

FIG. 77

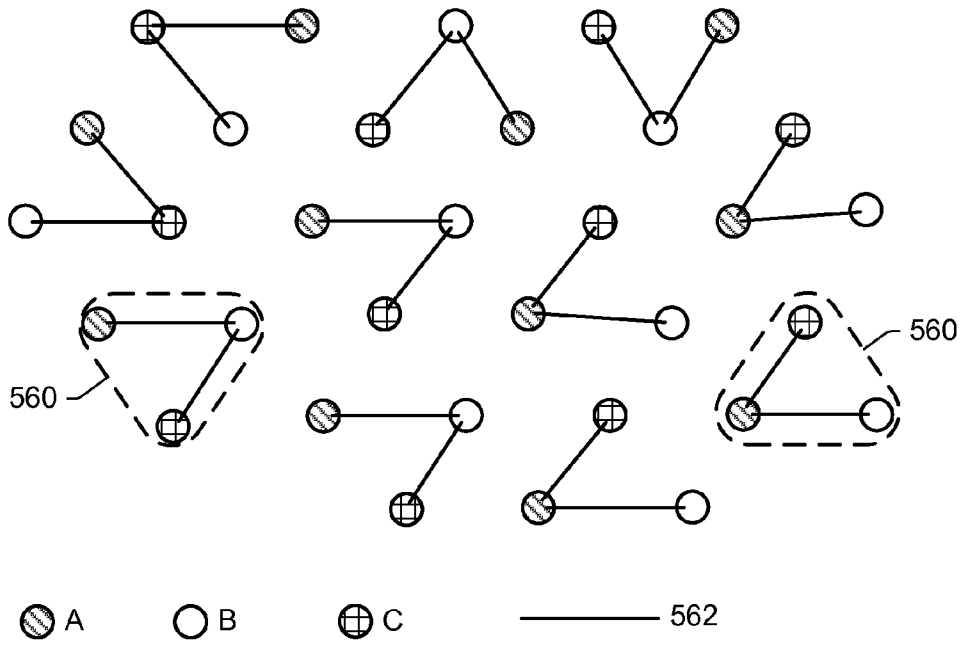

FIG. 78

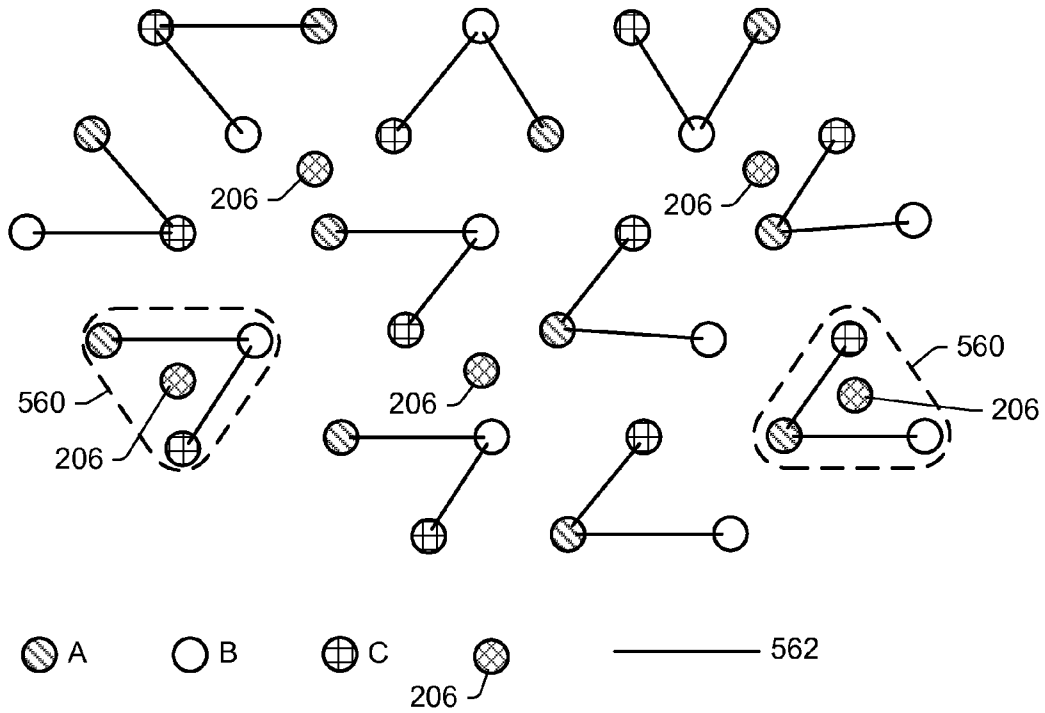

FIG. 79

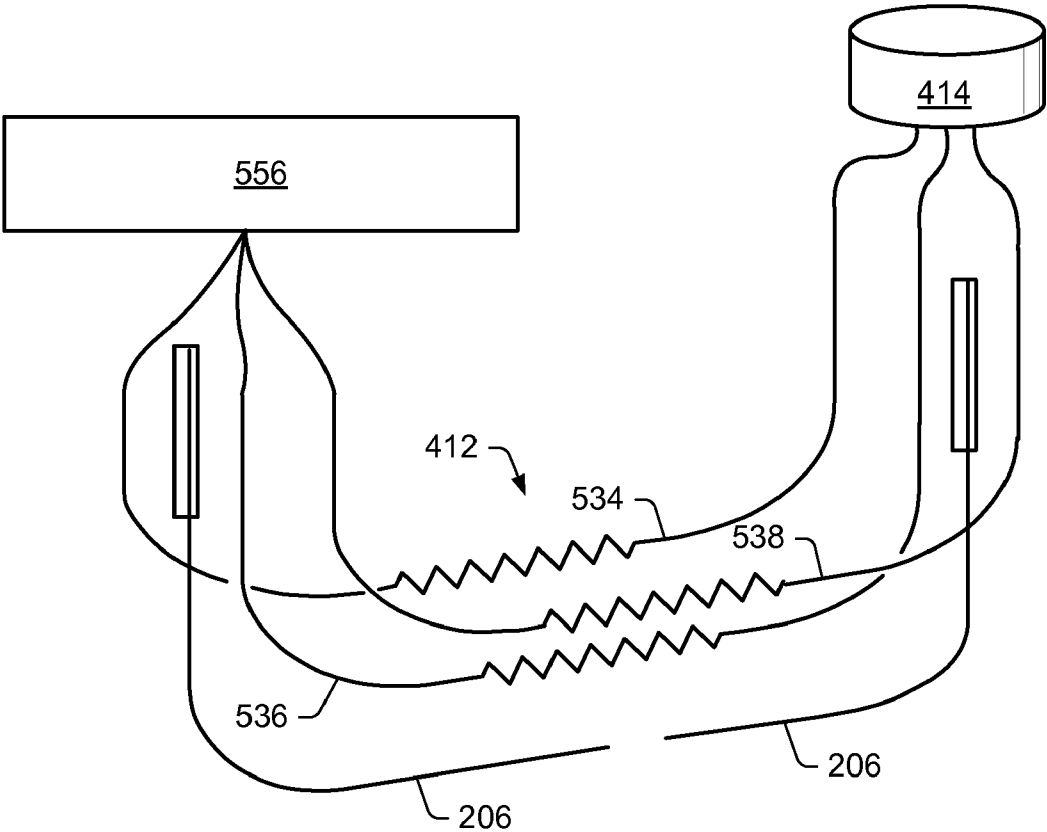

FIG. 80

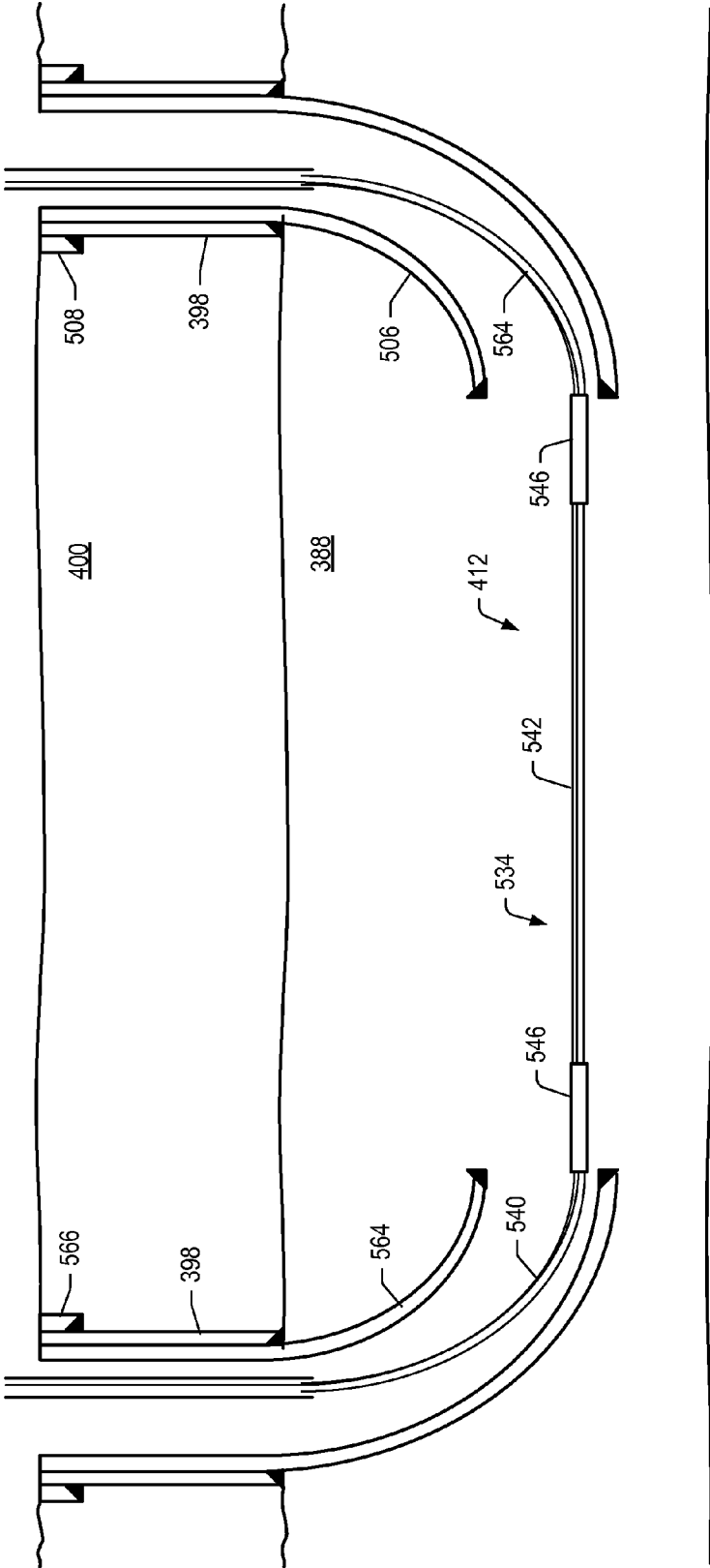

FIG. 81

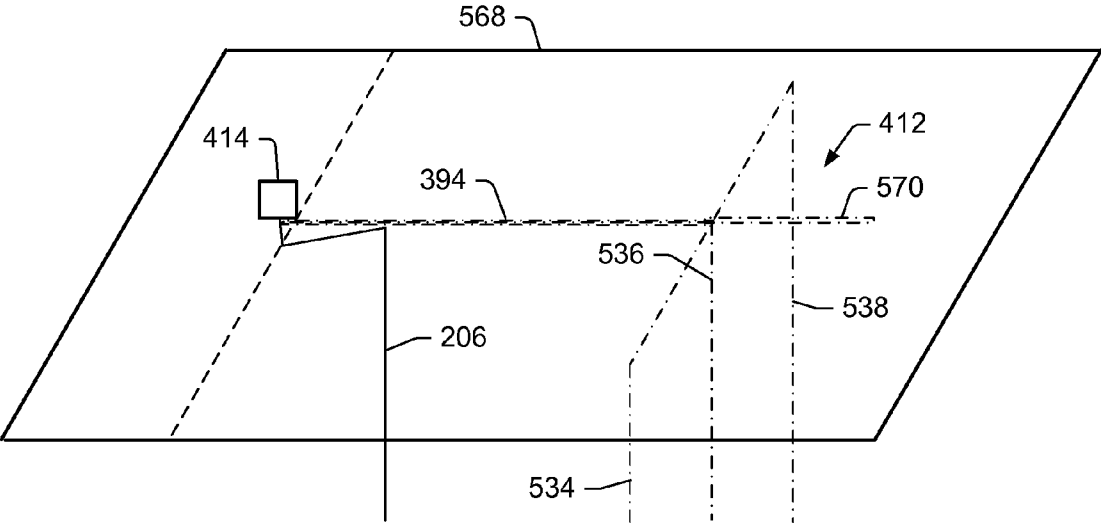

FIG. 82

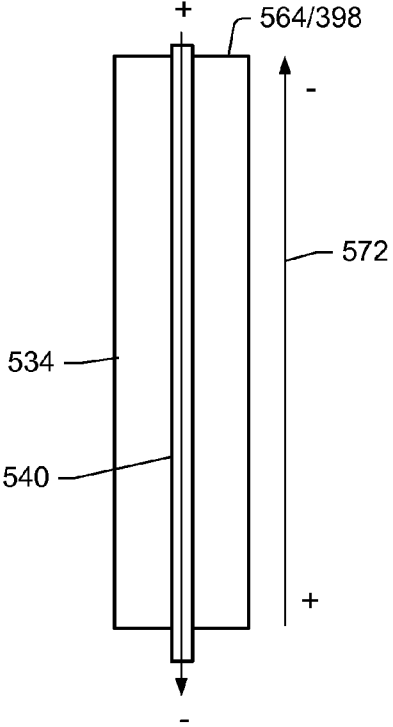

FIG. 83

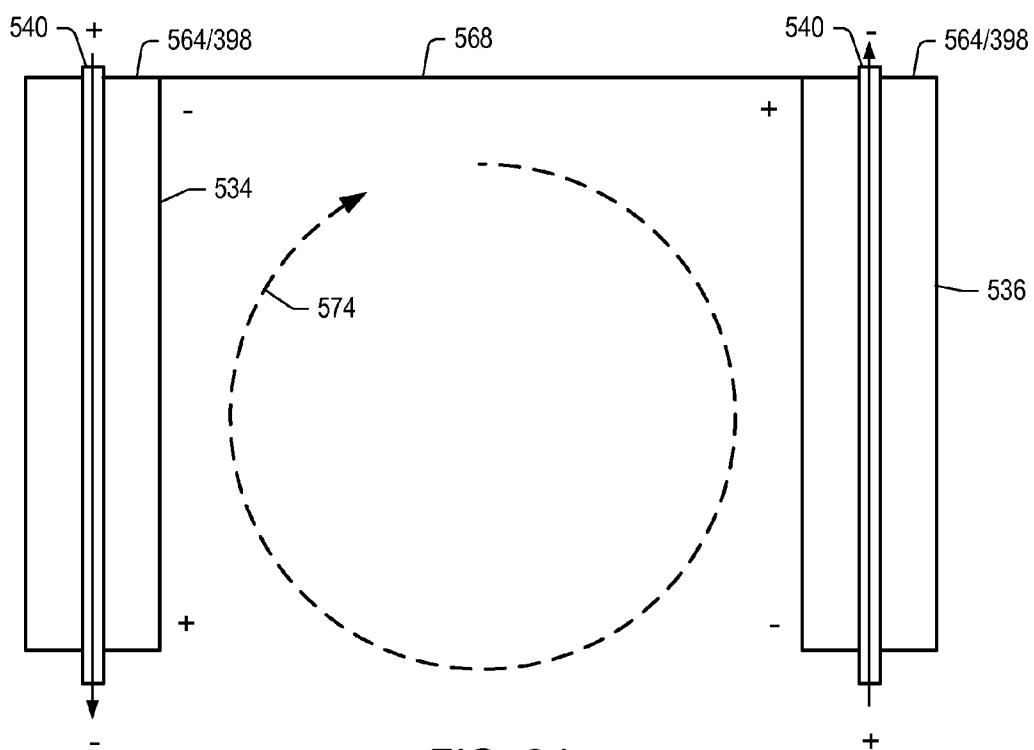

FIG. 84

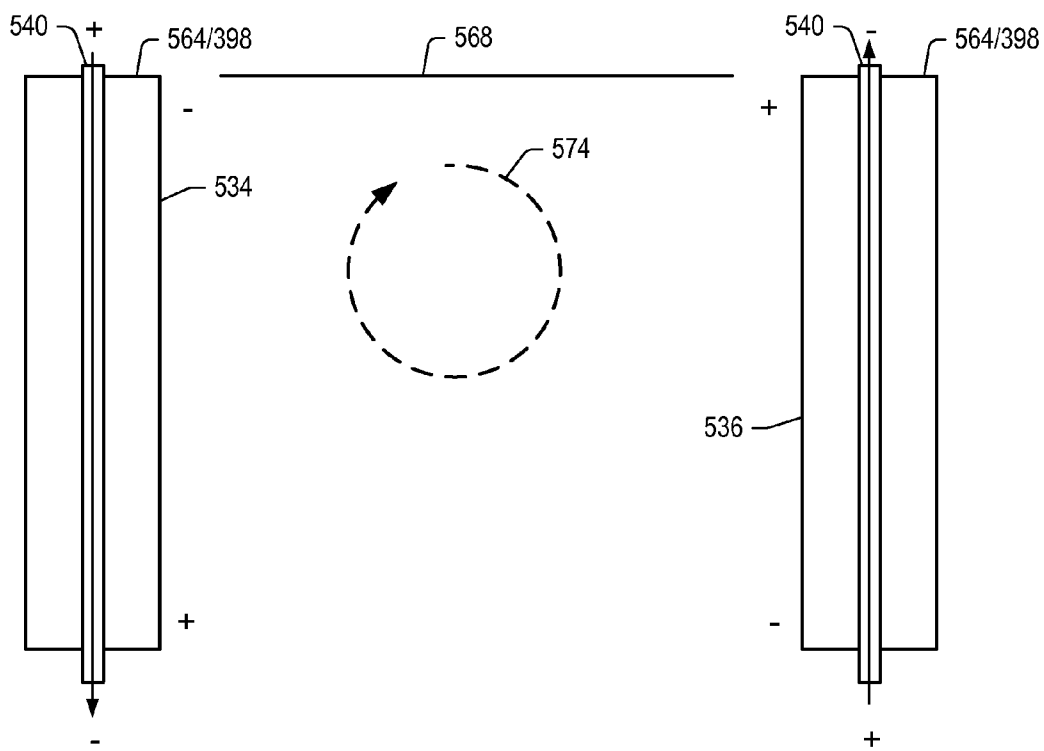

FIG. 85

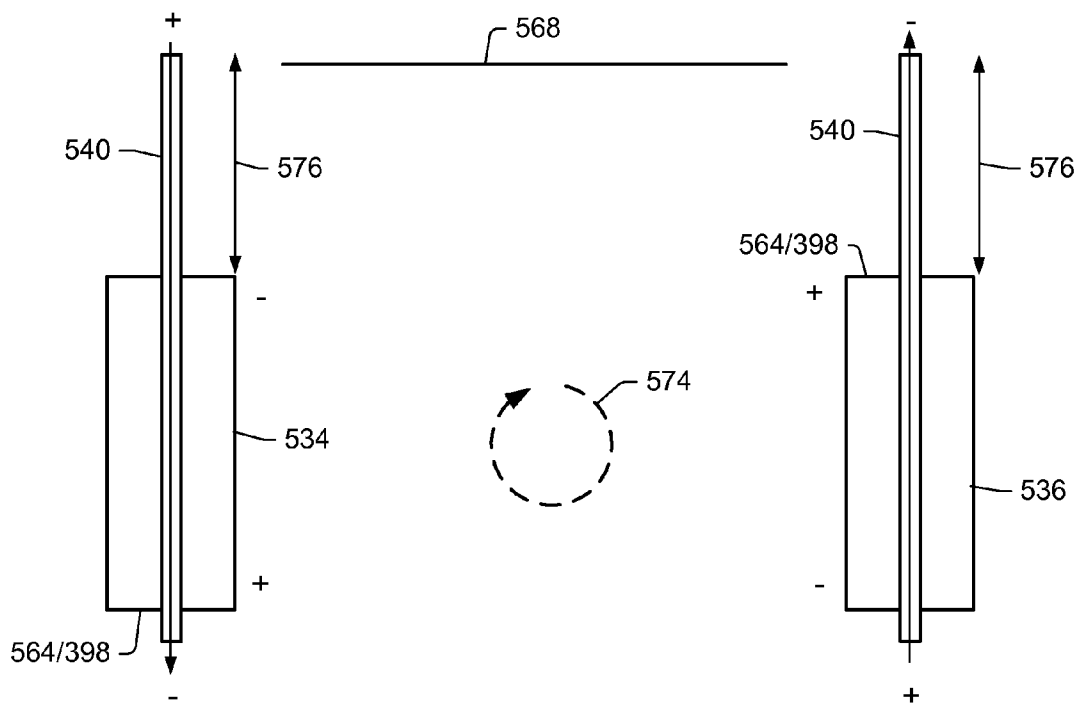

FIG. 86

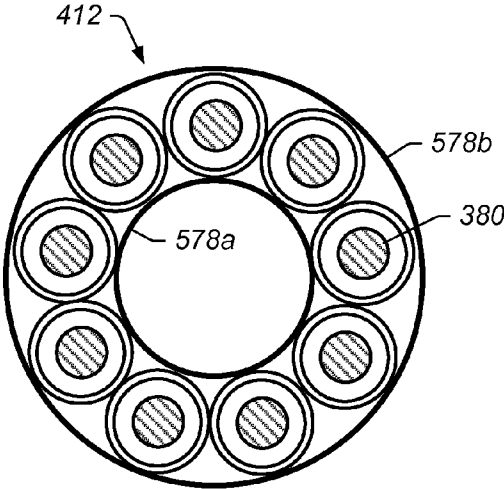

FIG. 87

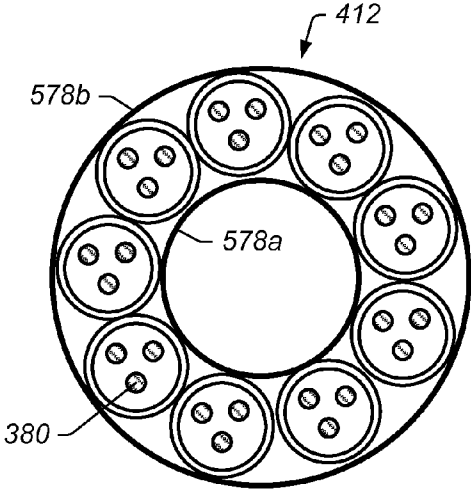

FIG. 89

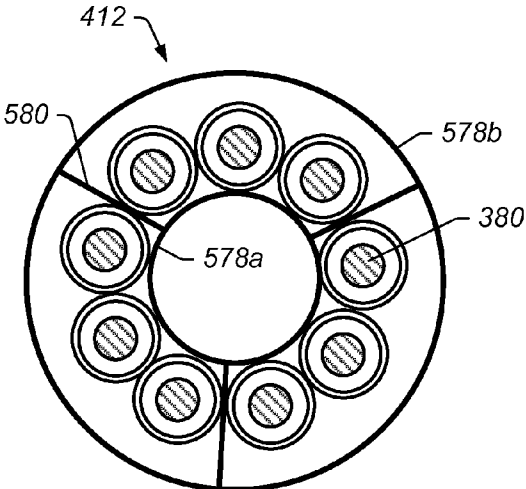

FIG. 88

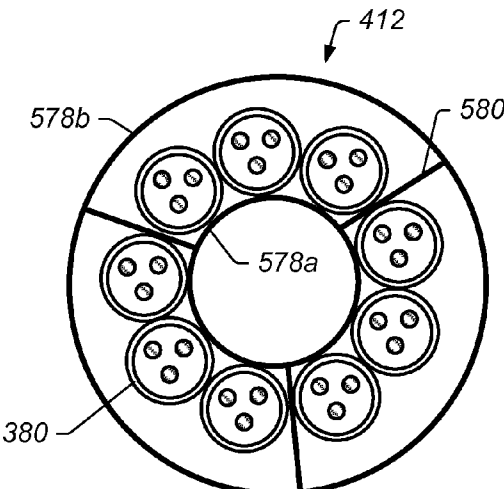

FIG. 90

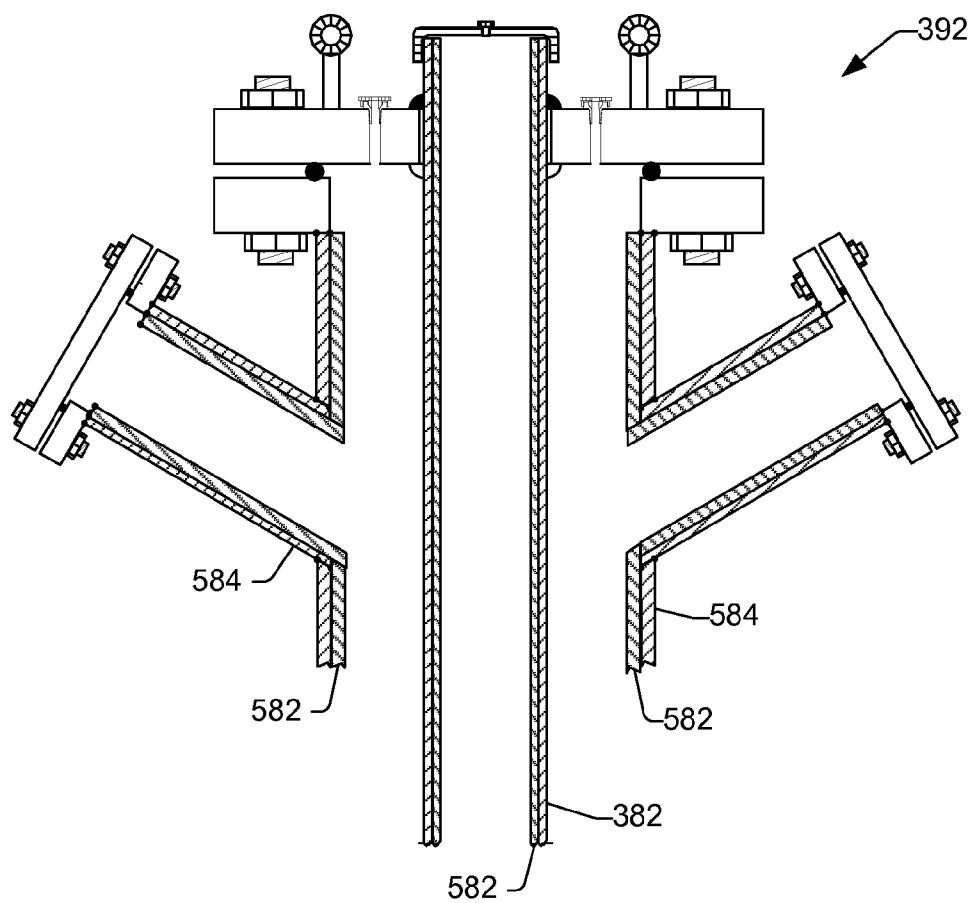

FIG. 91

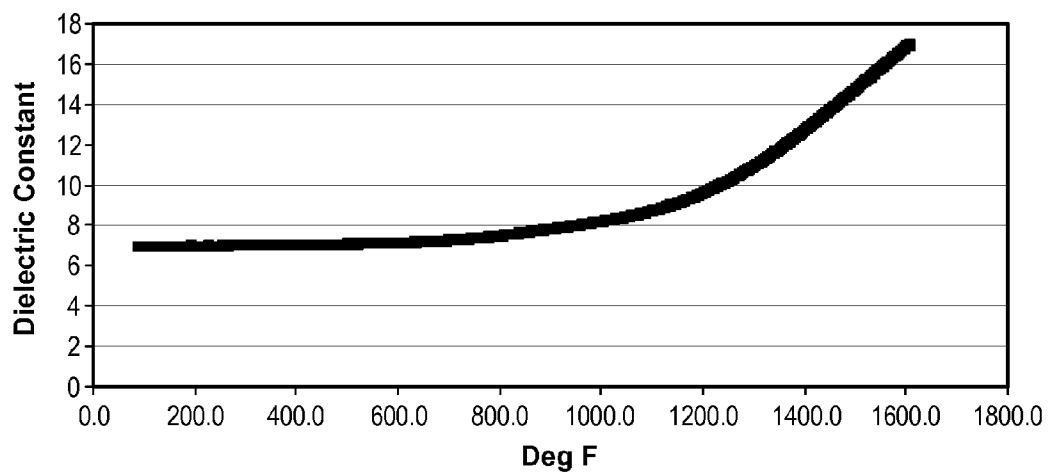

FIG. 92

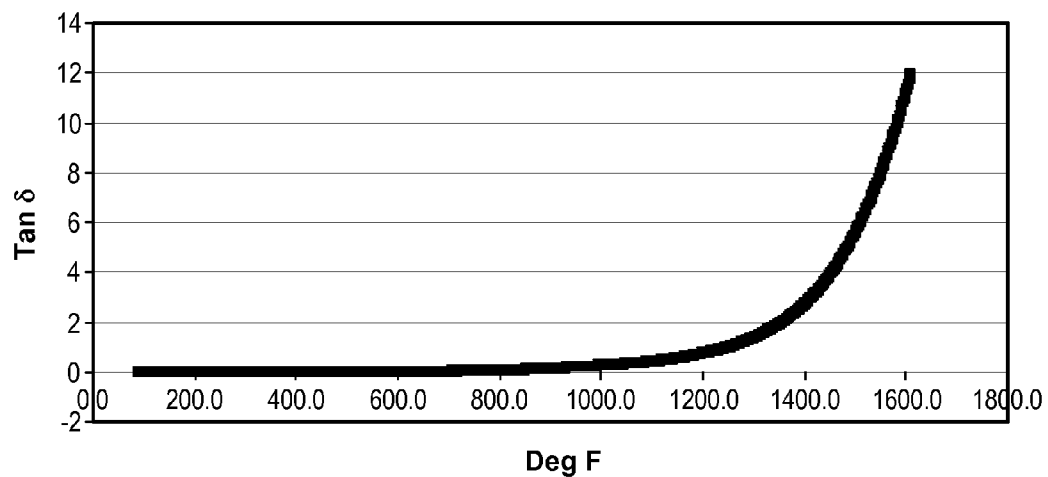

FIG. 93

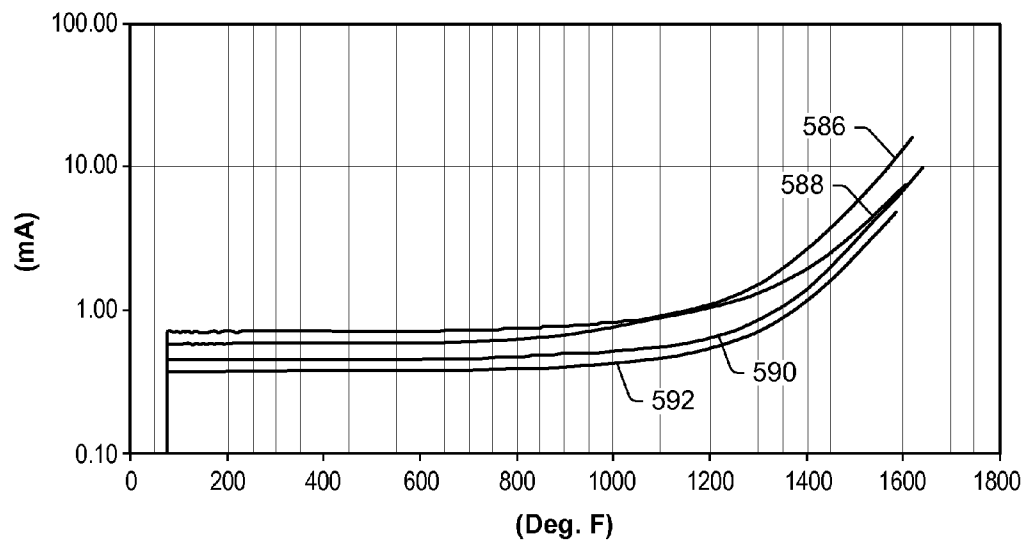

FIG. 94

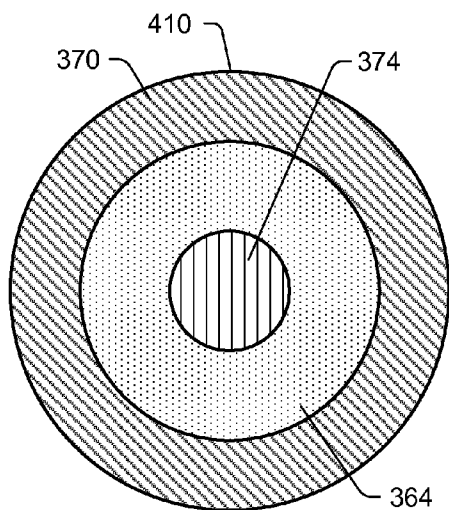

FIG. 95

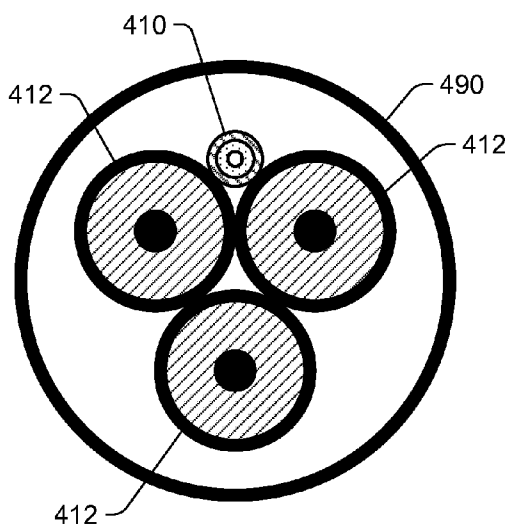

FIG. 96

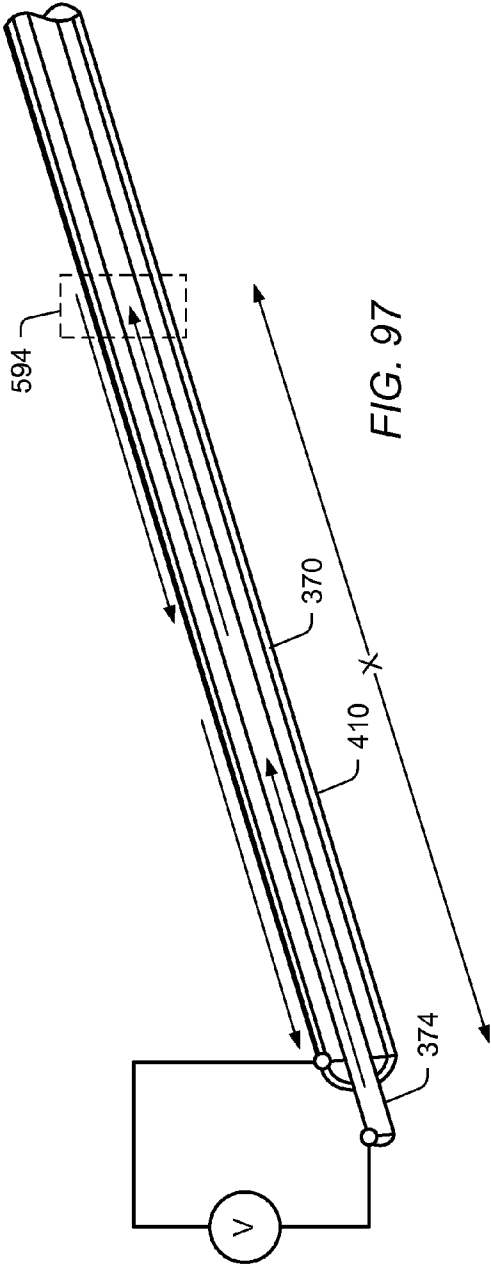

FIG. 97

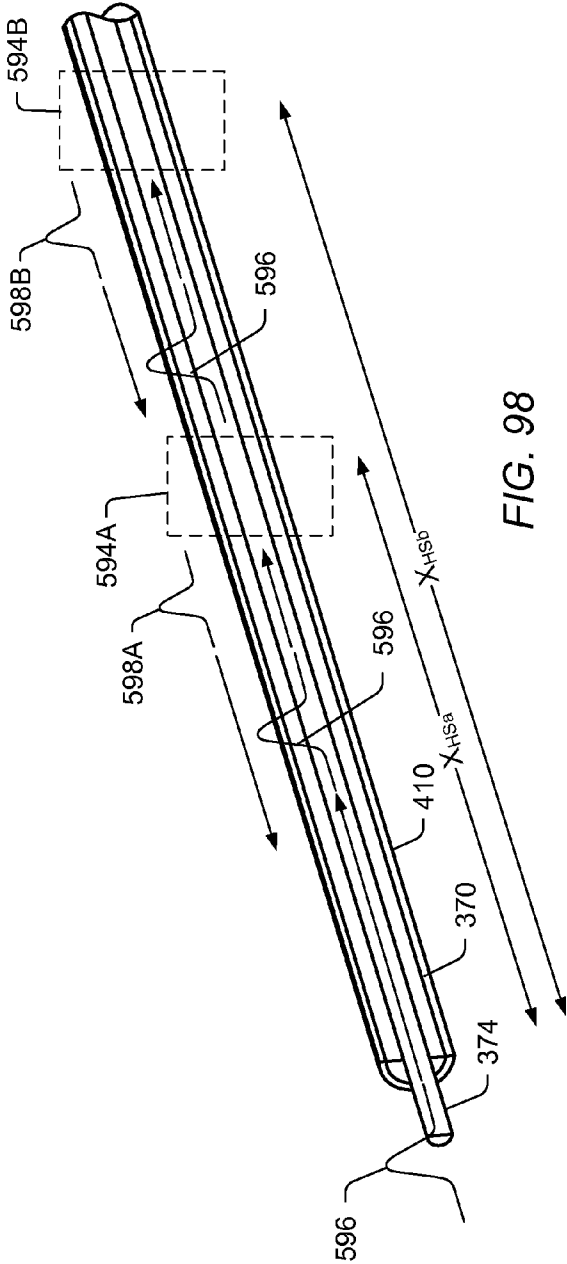

FIG. 98

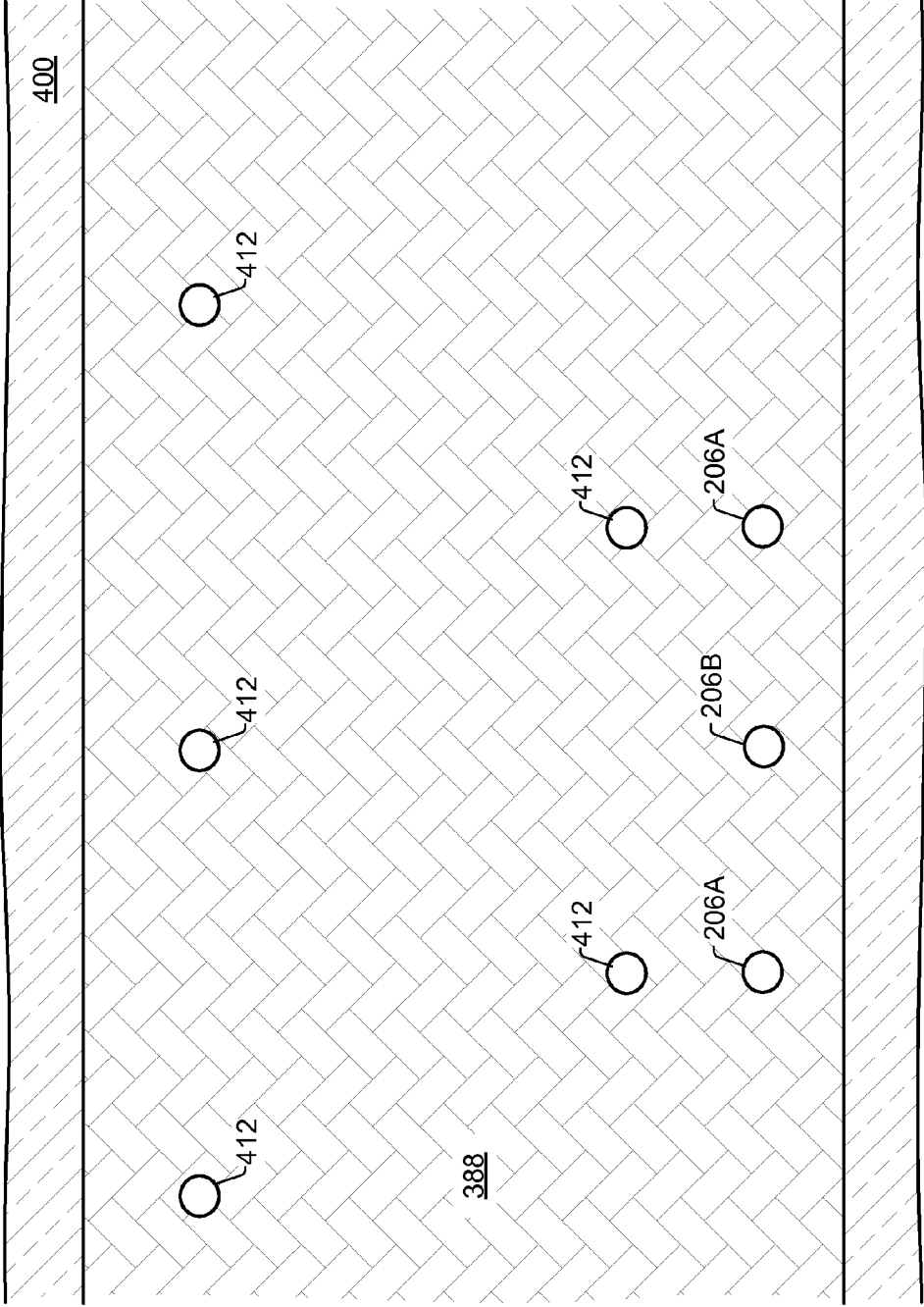

FIG. 99

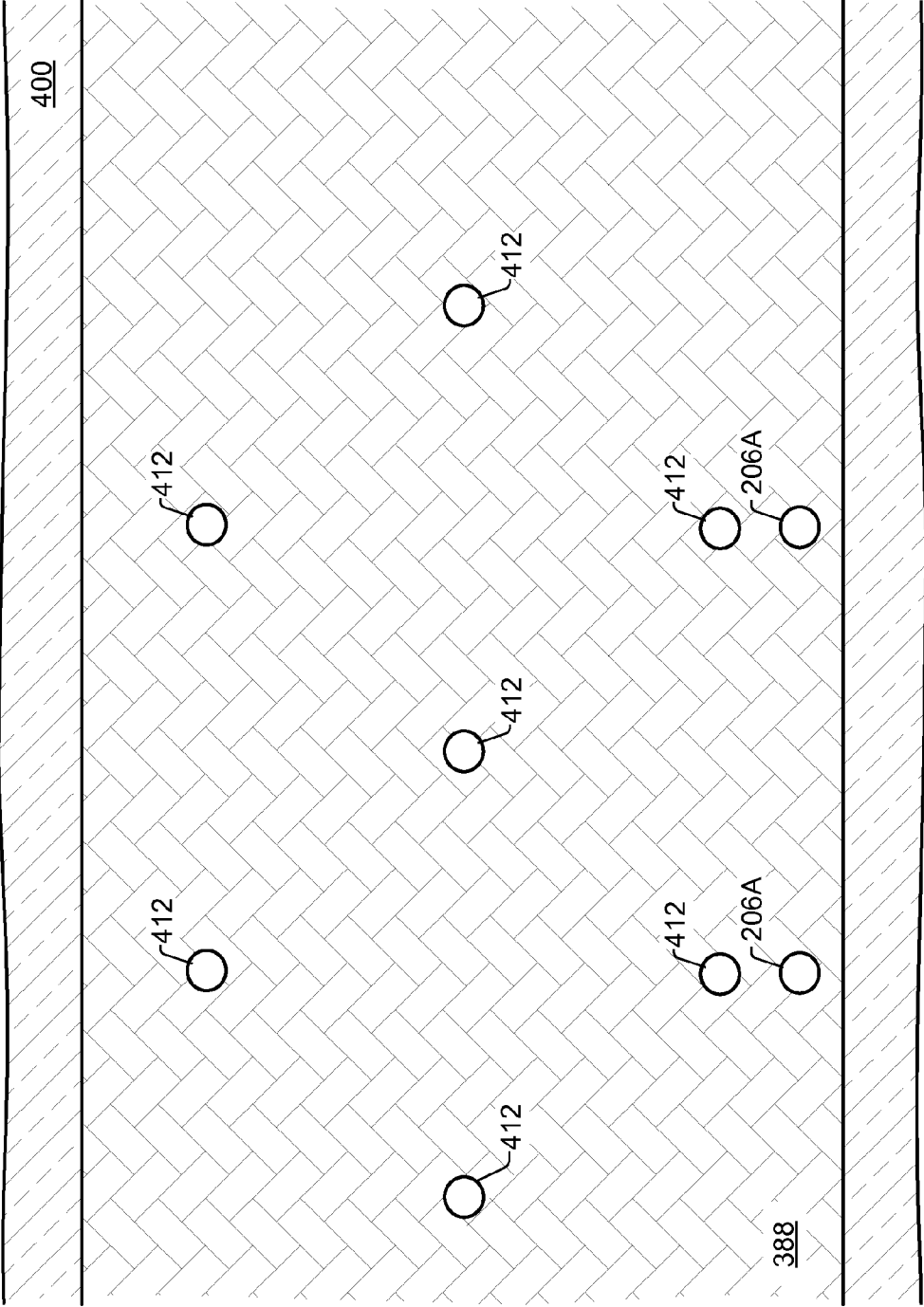

FIG. 100

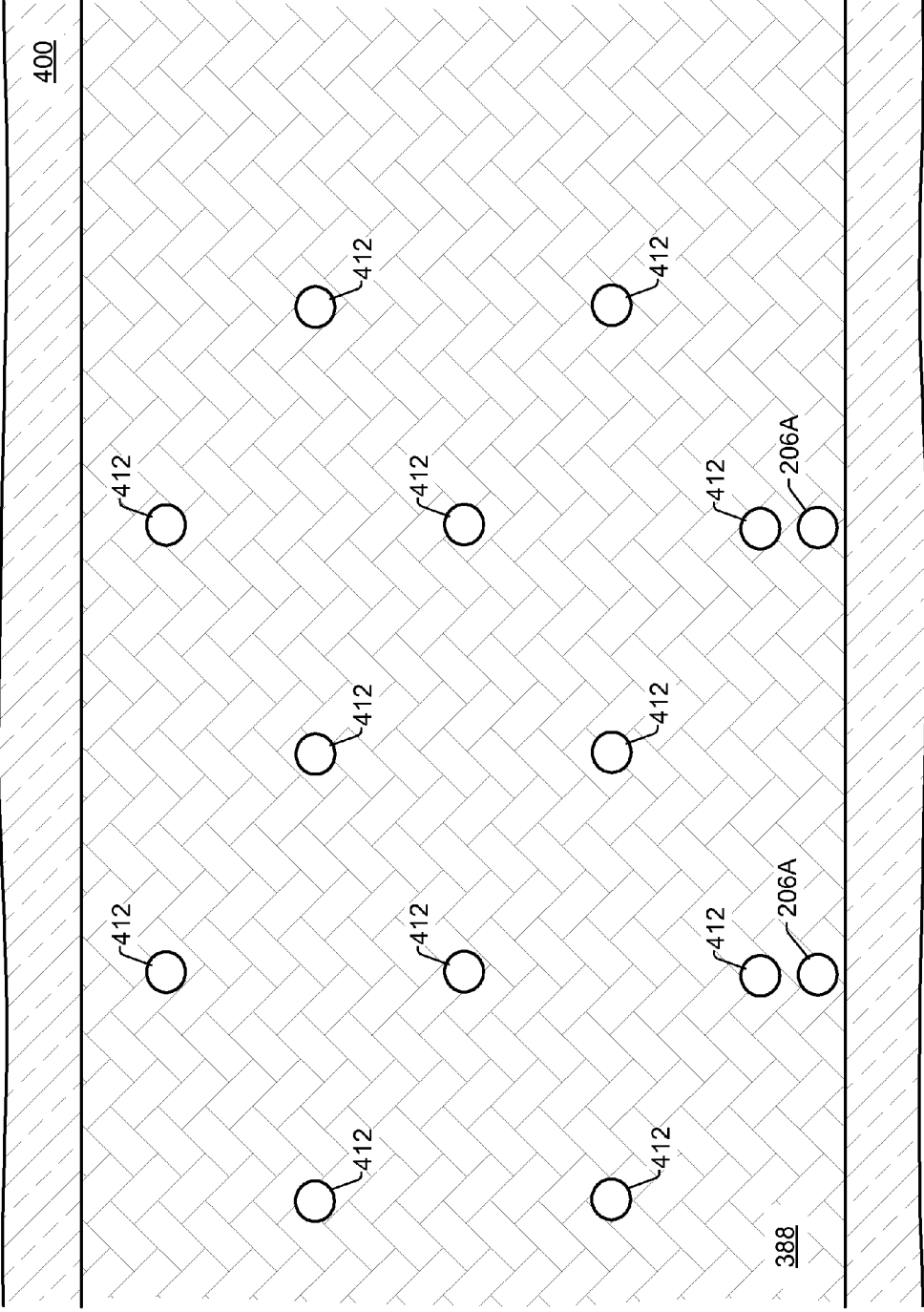

FIG. 101

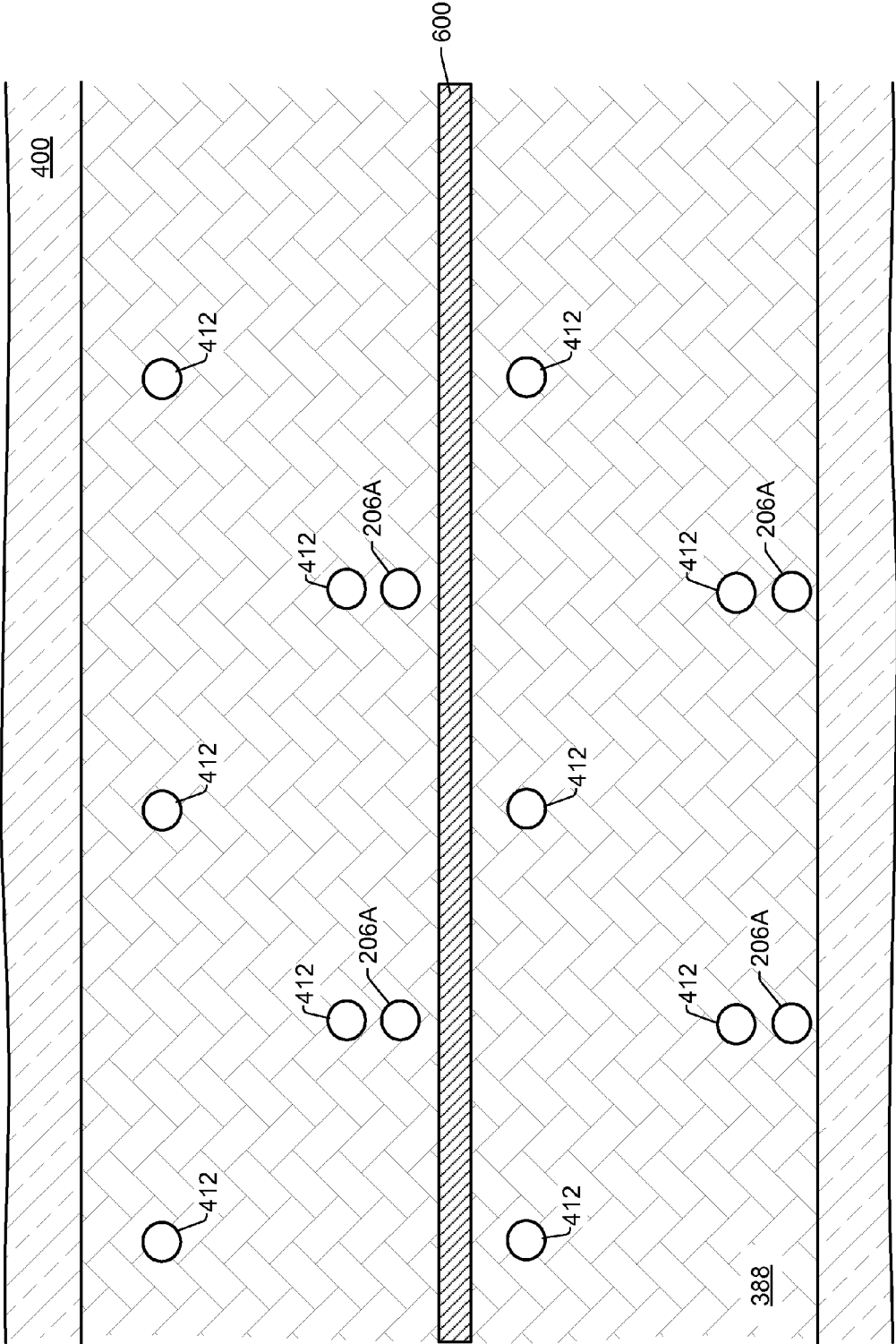

FIG. 102

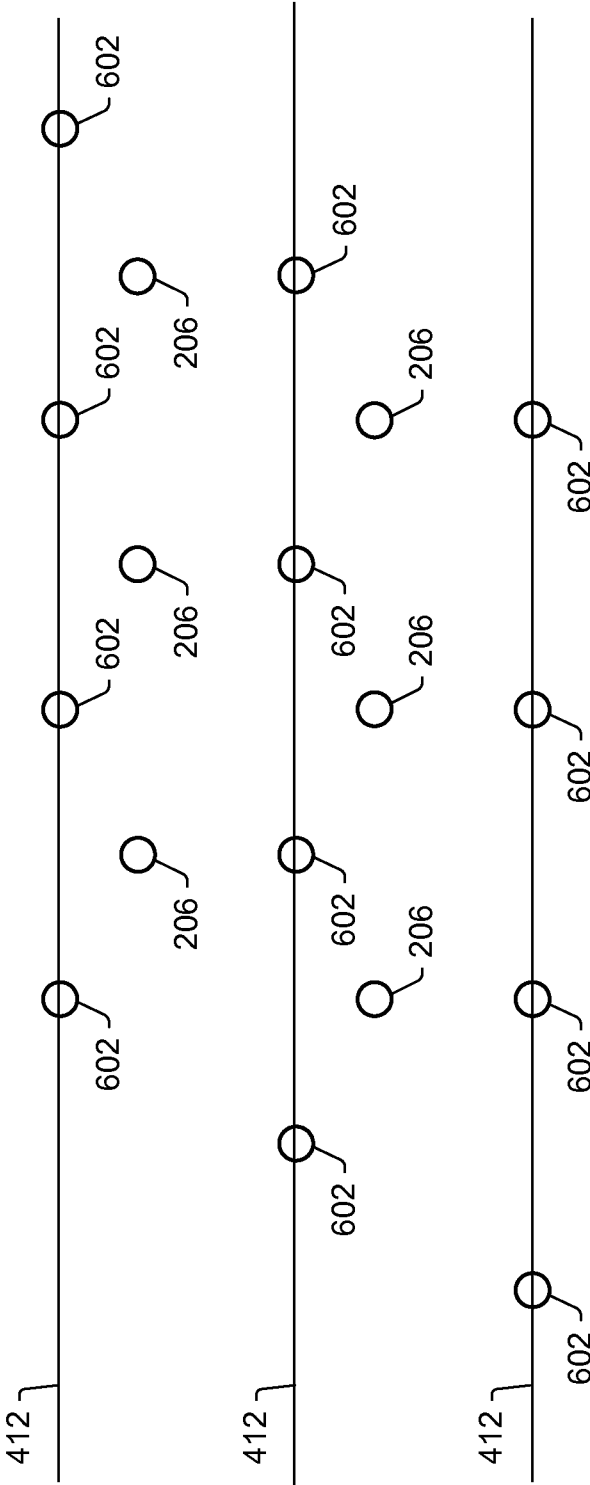

FIG. 103

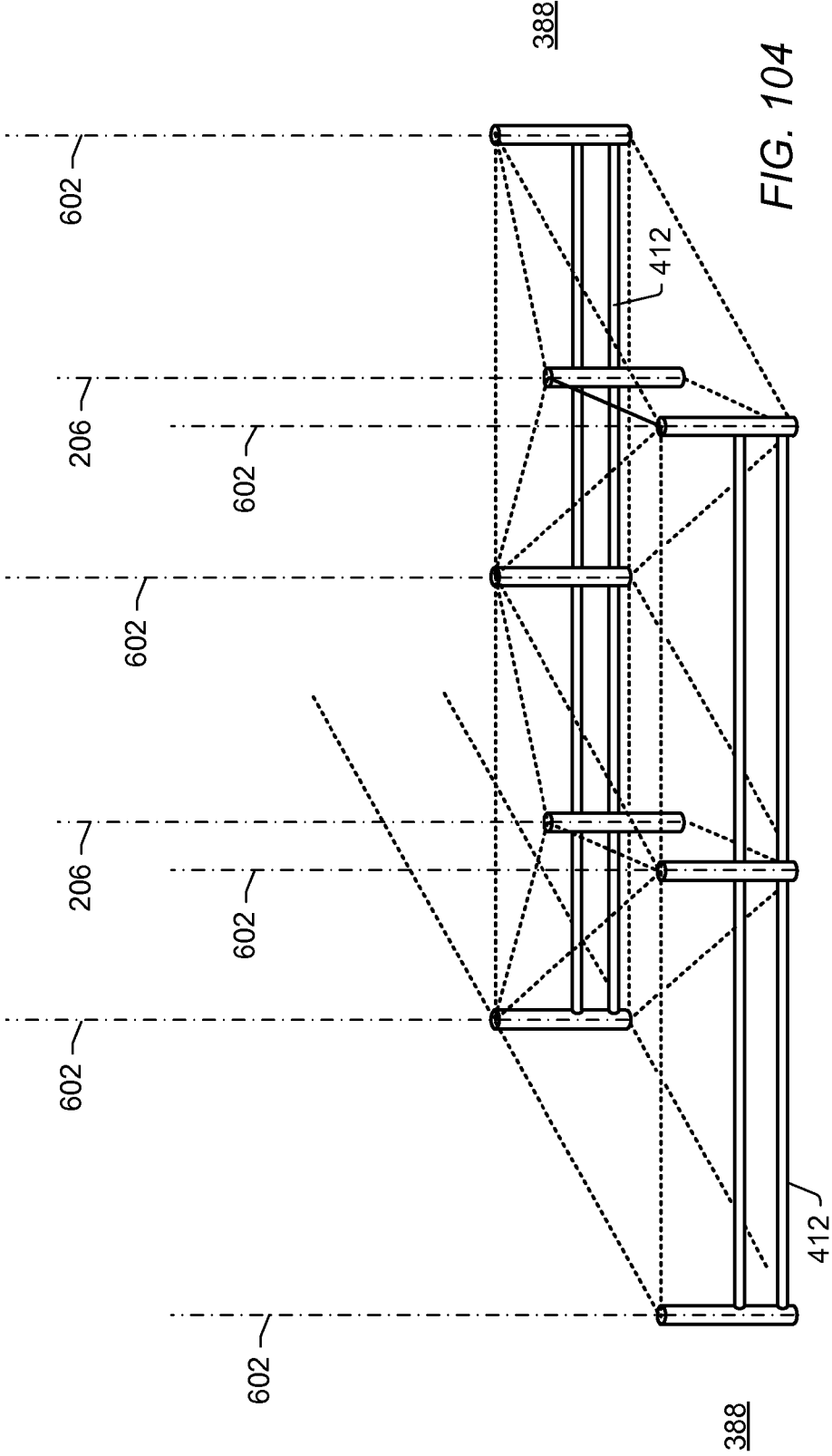

FIG. 104

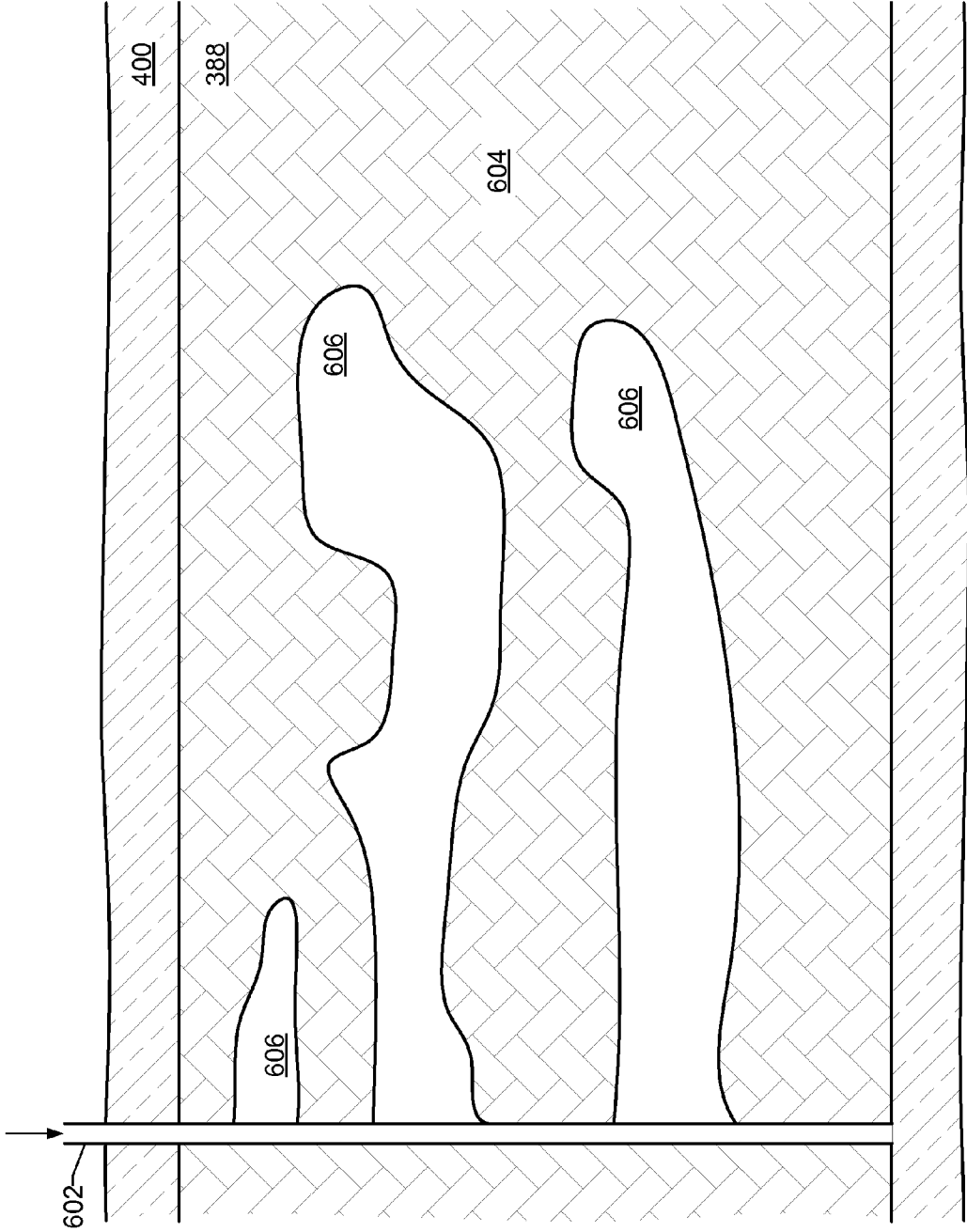

FIG. 105

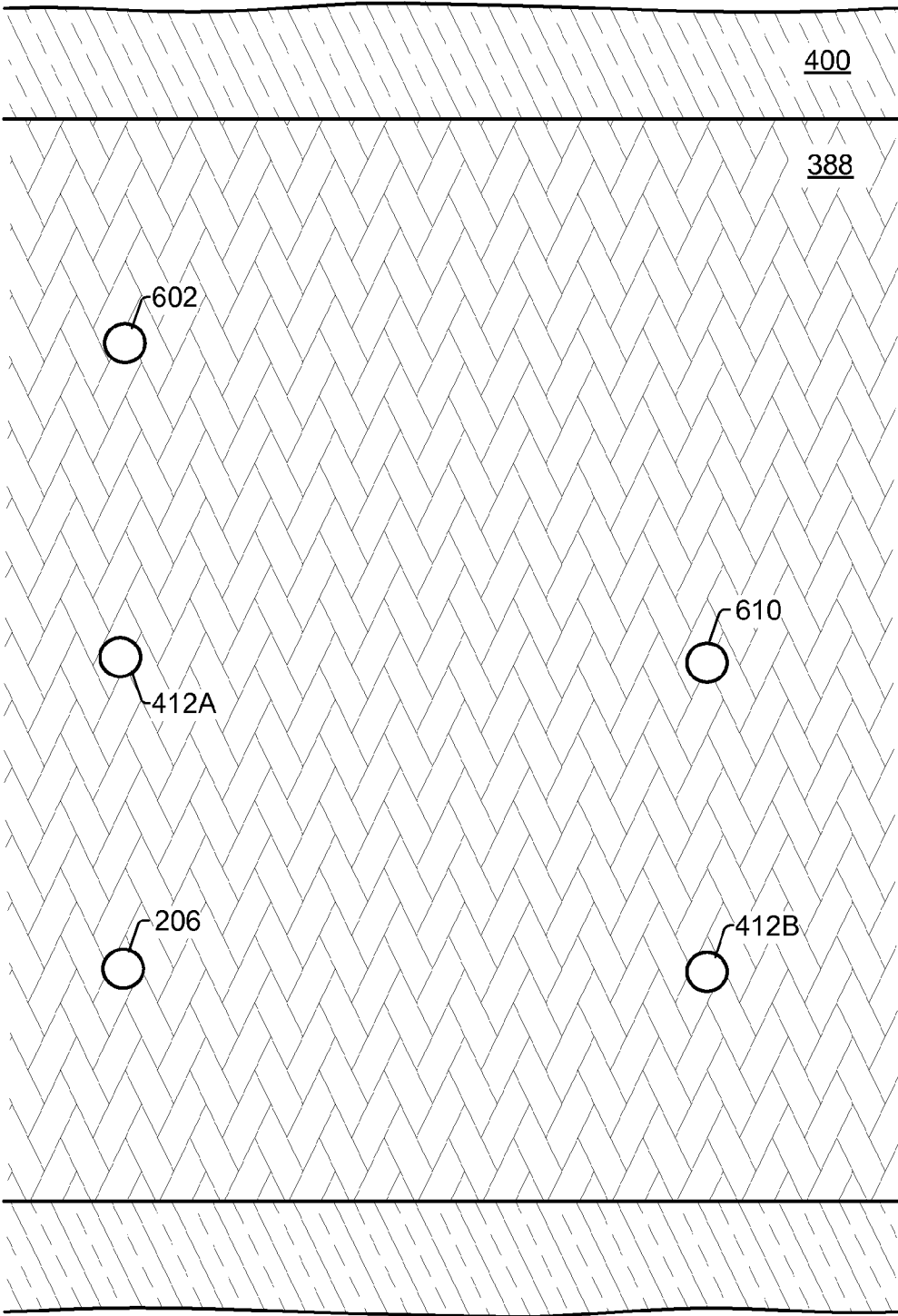

FIG. 107

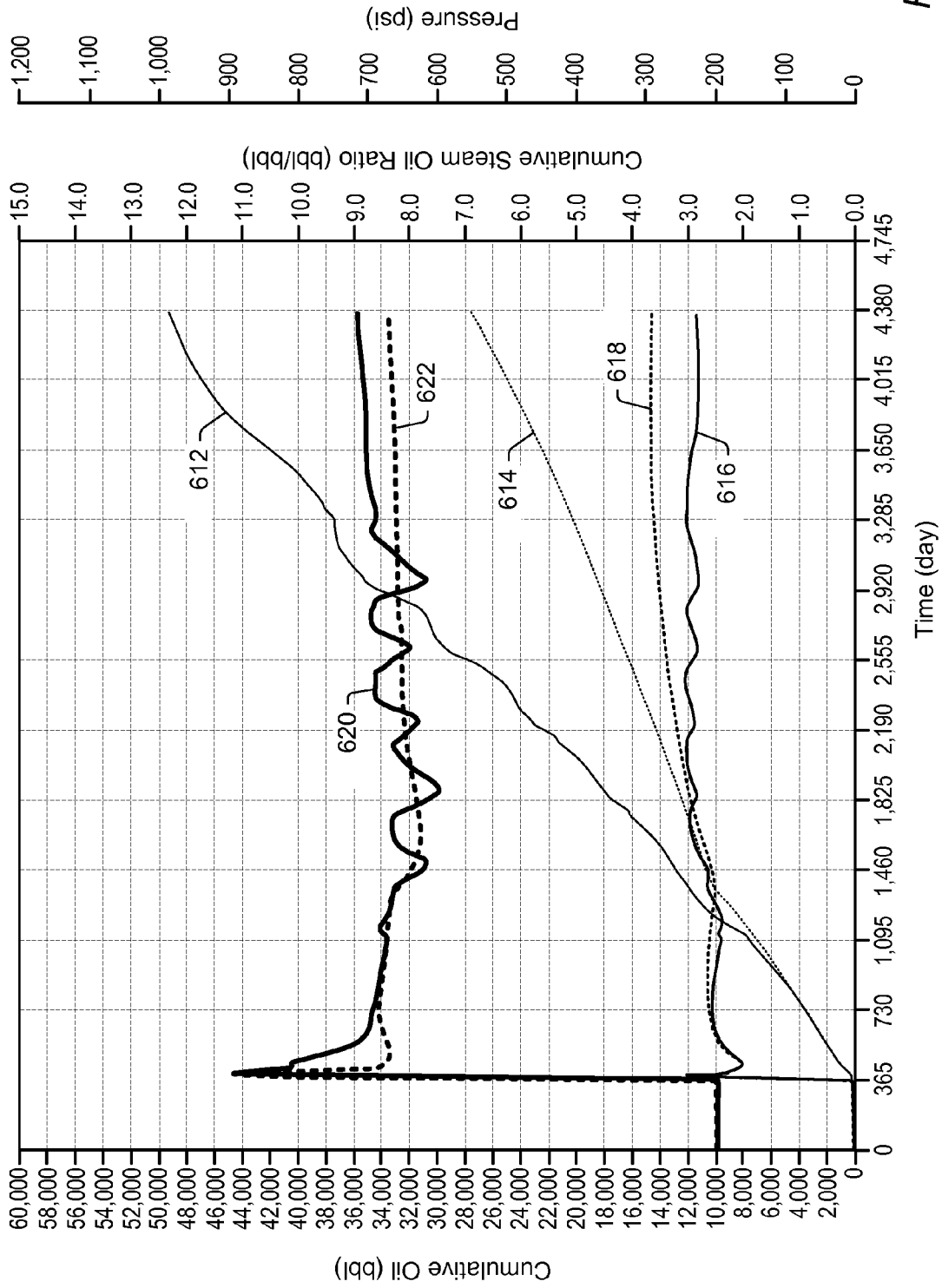

FIG. 108

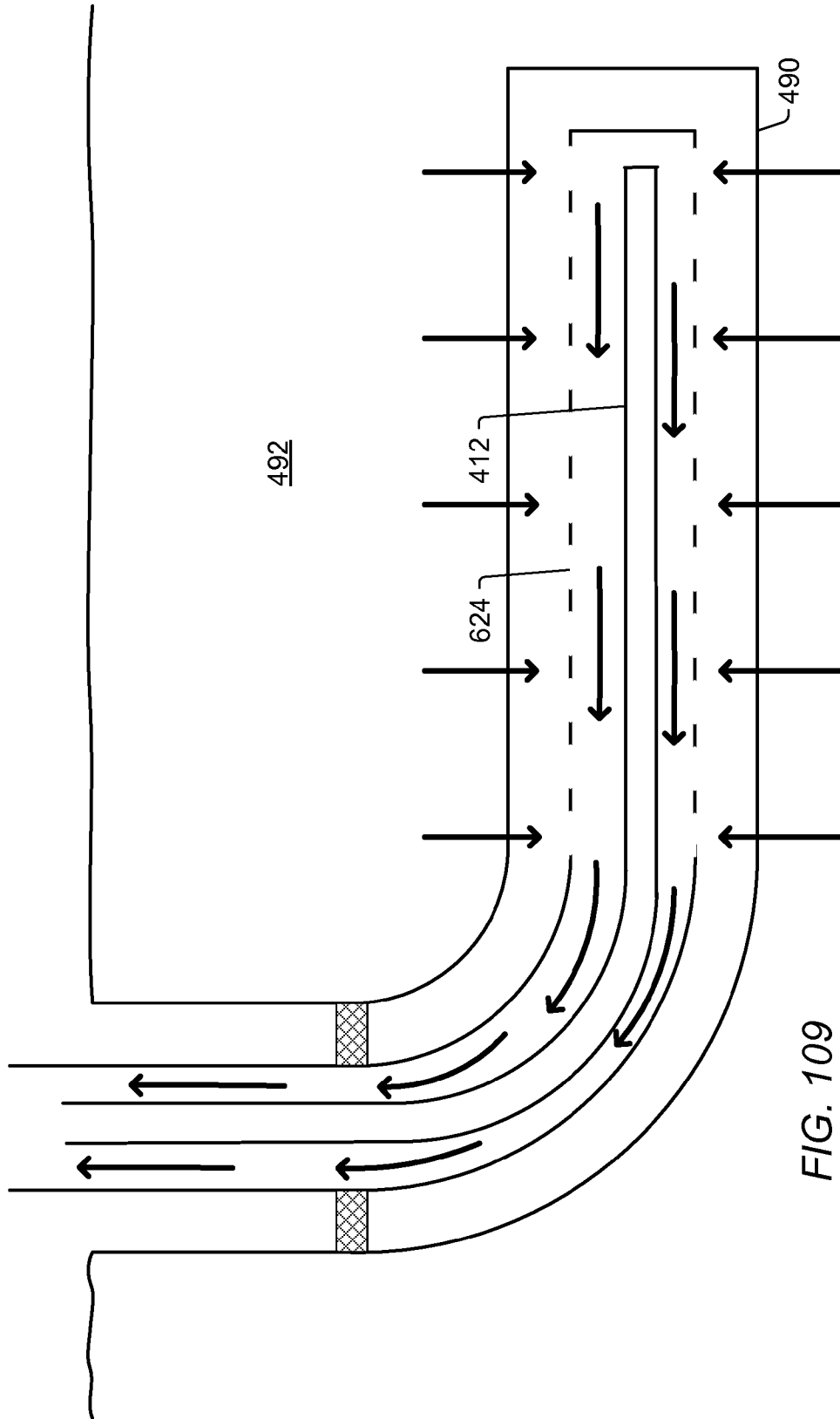

FIG. 109

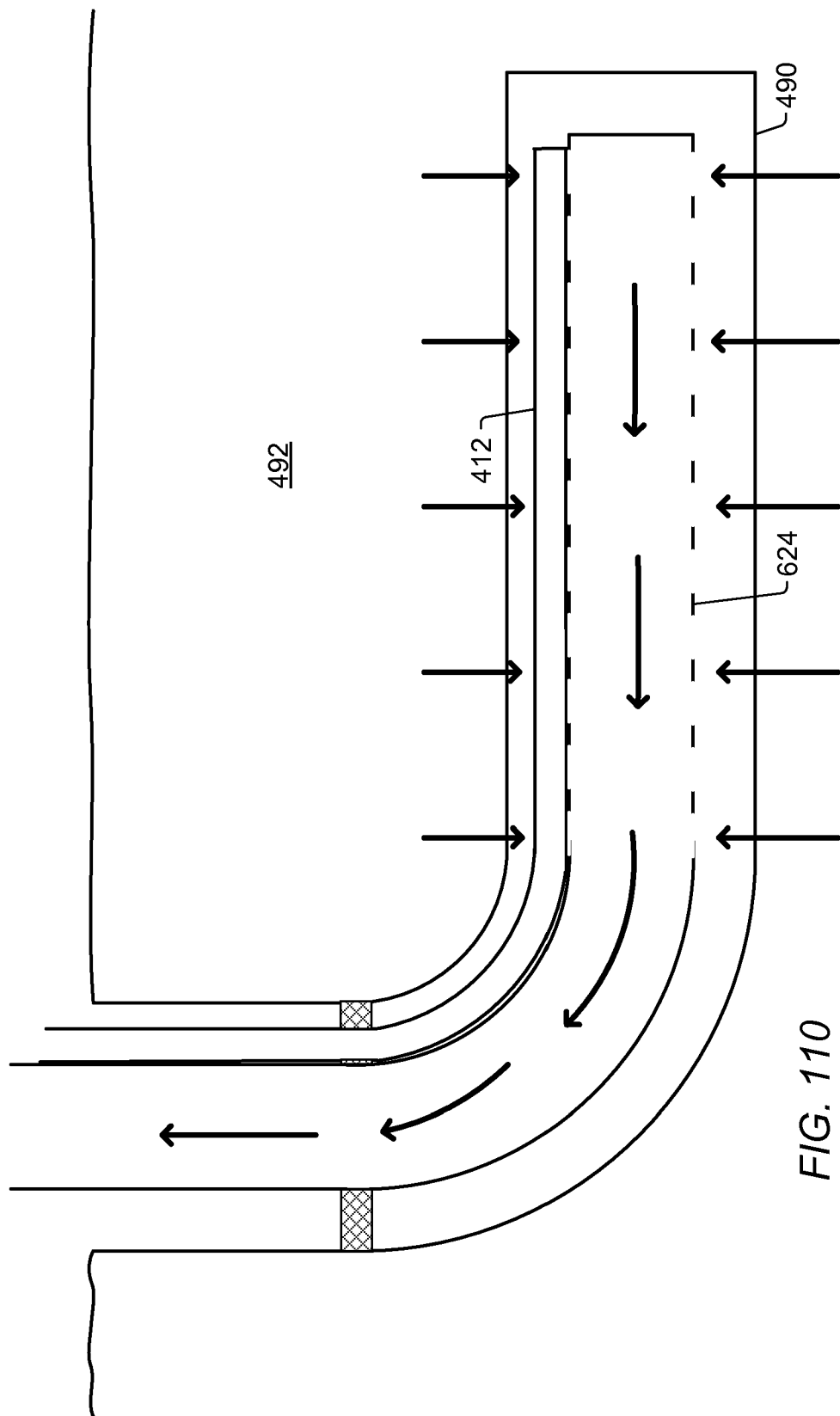

FIG. 110

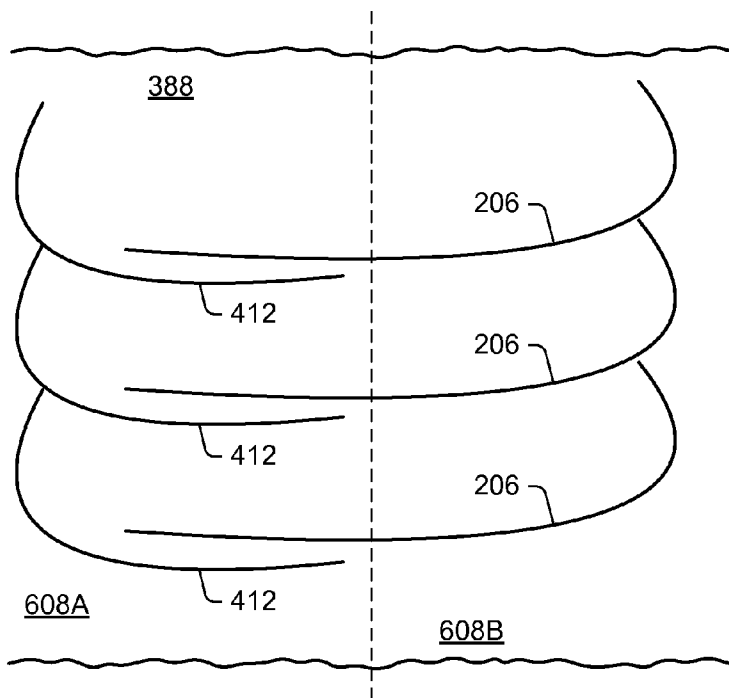

FIG. 111

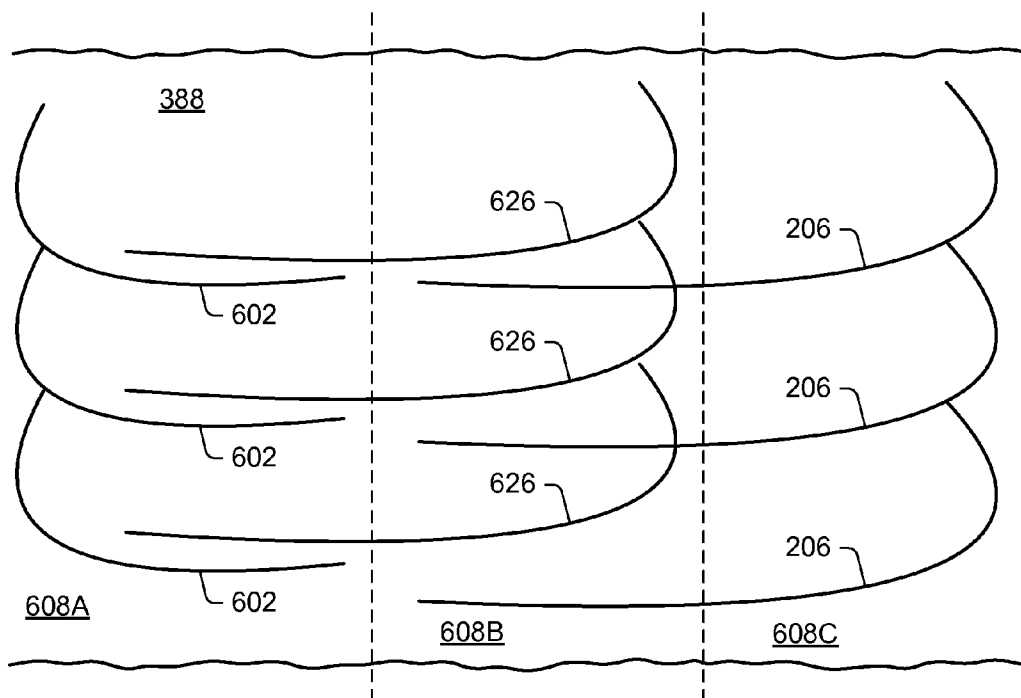

FIG. 112

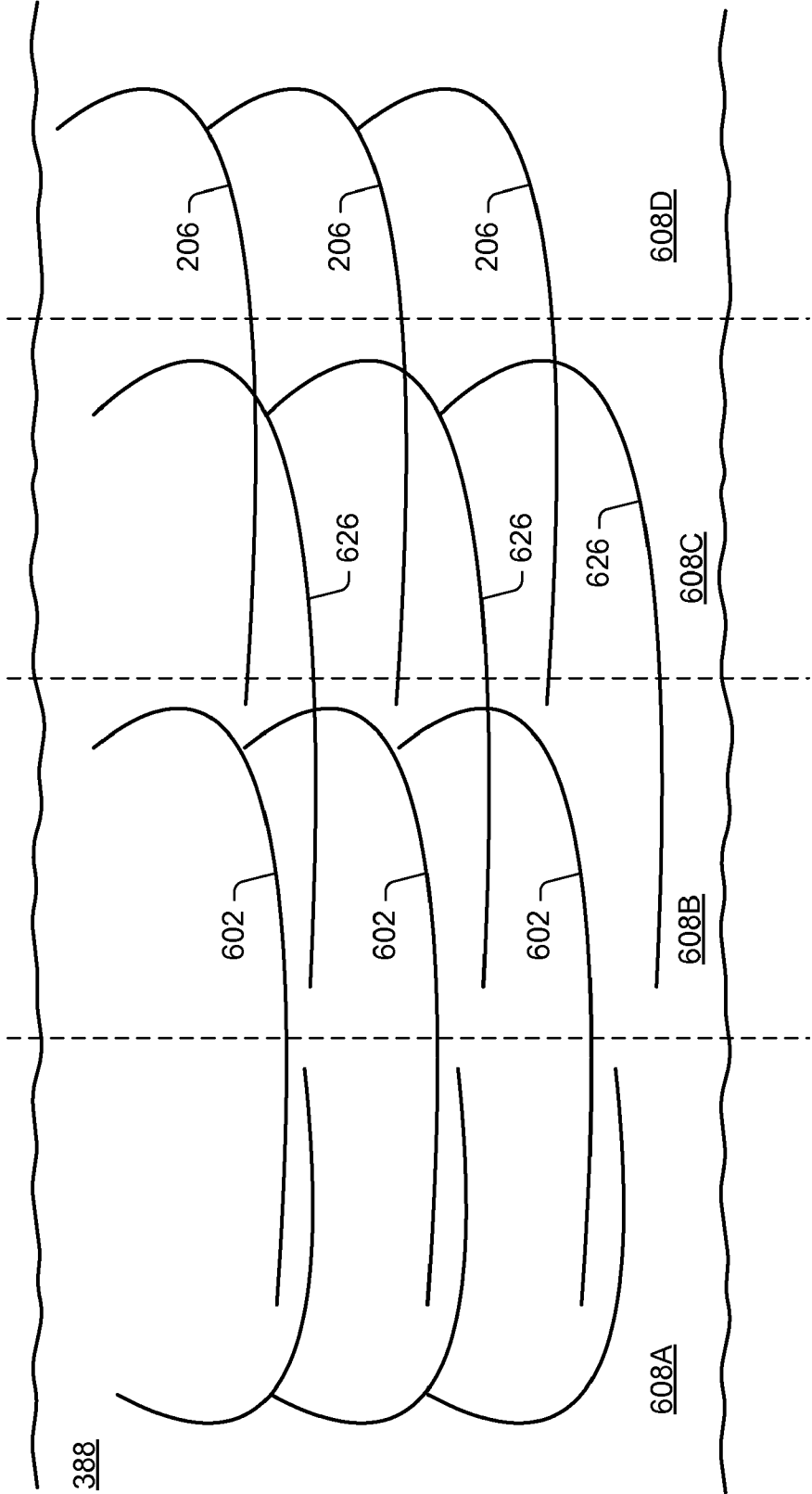

FIG. 113

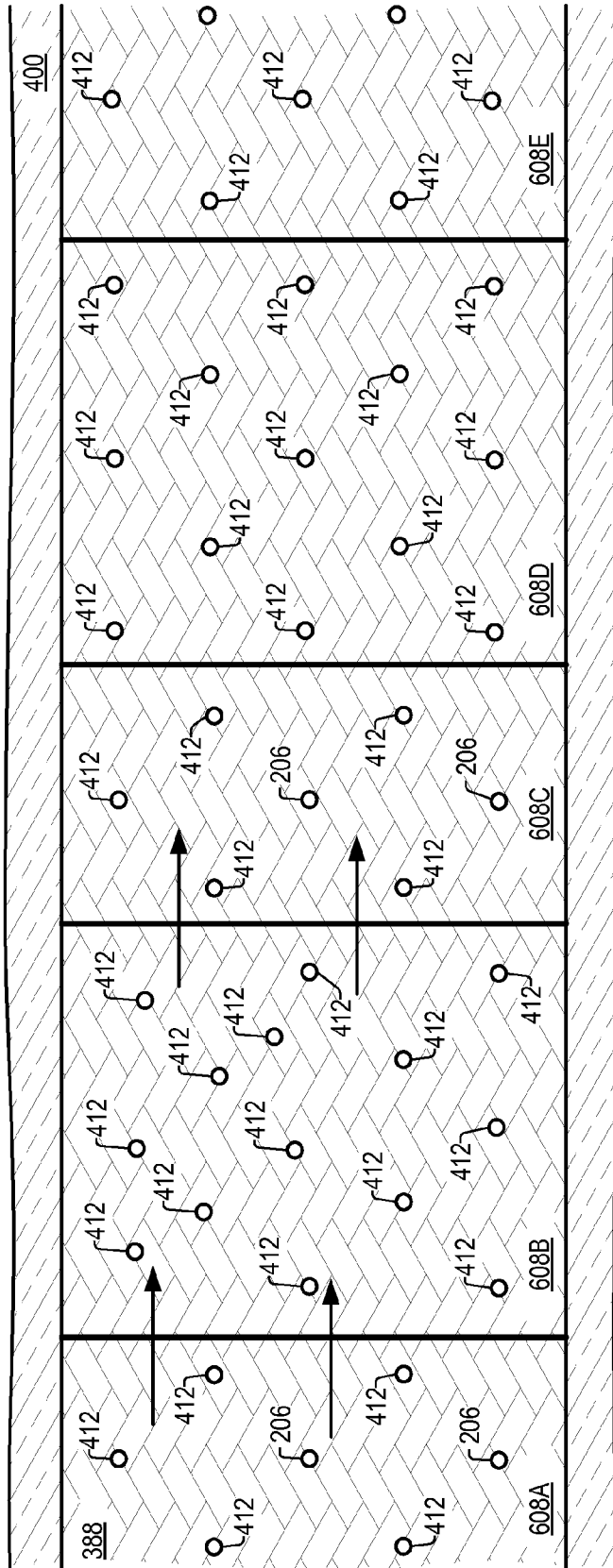

FIG. 114

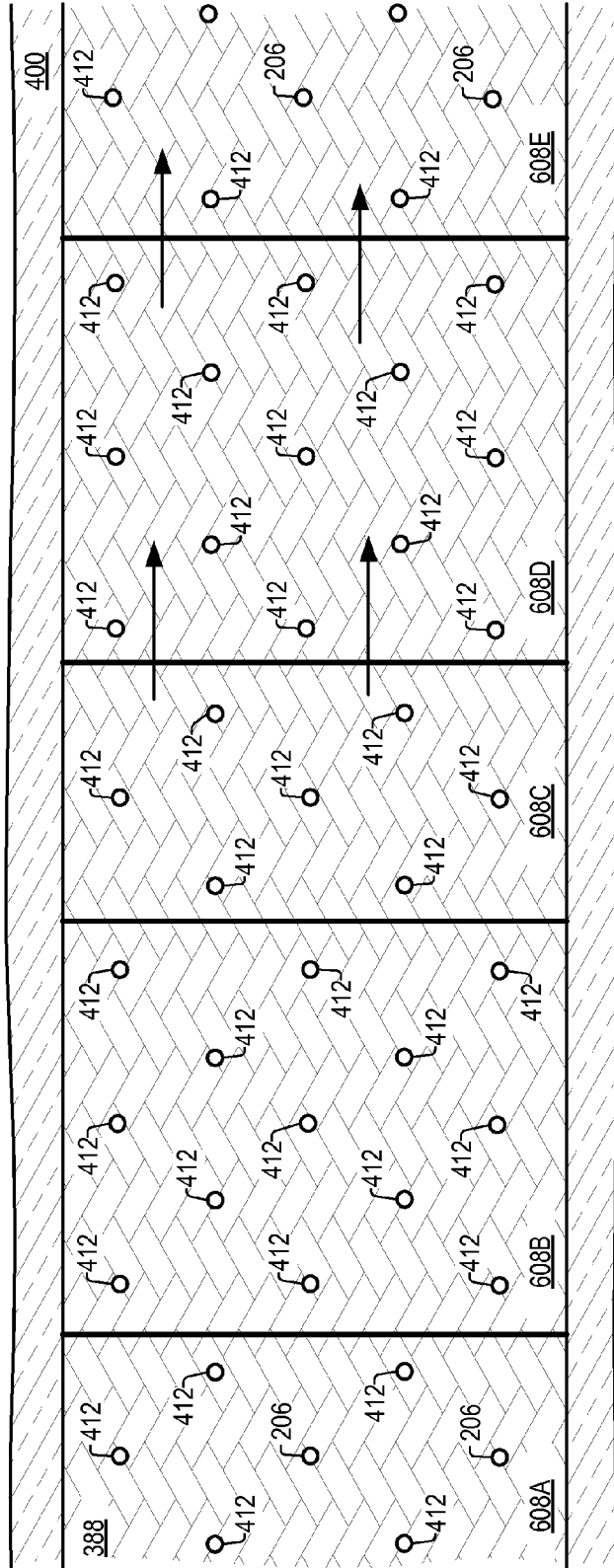

FIG. 115

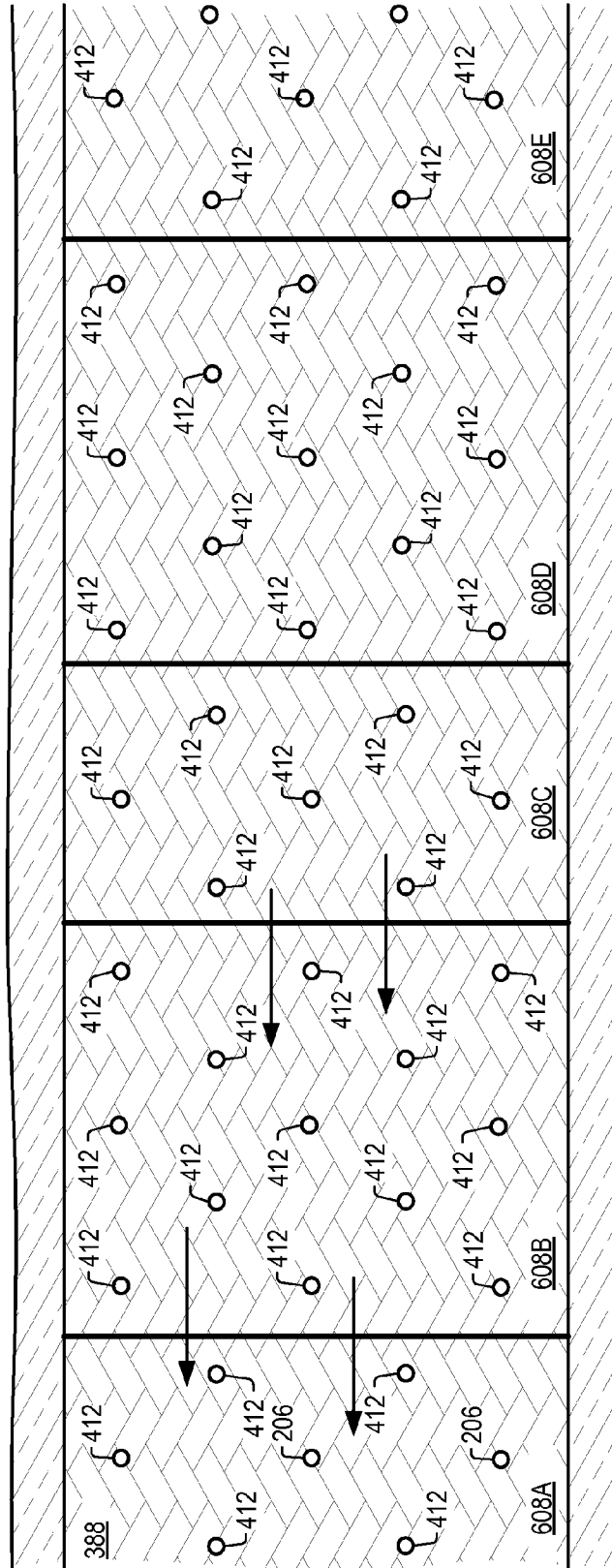

FIG. 116

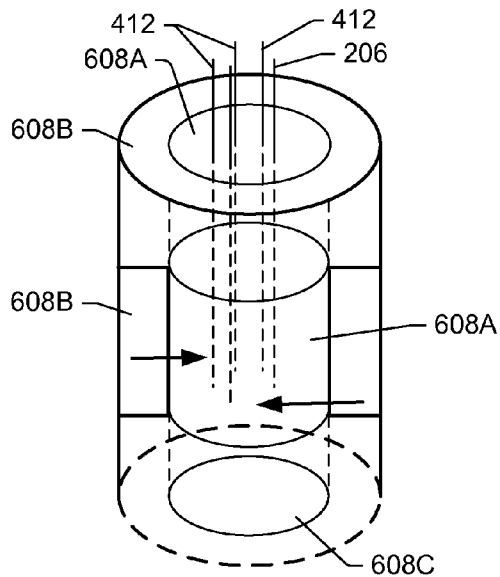

FIG. 117

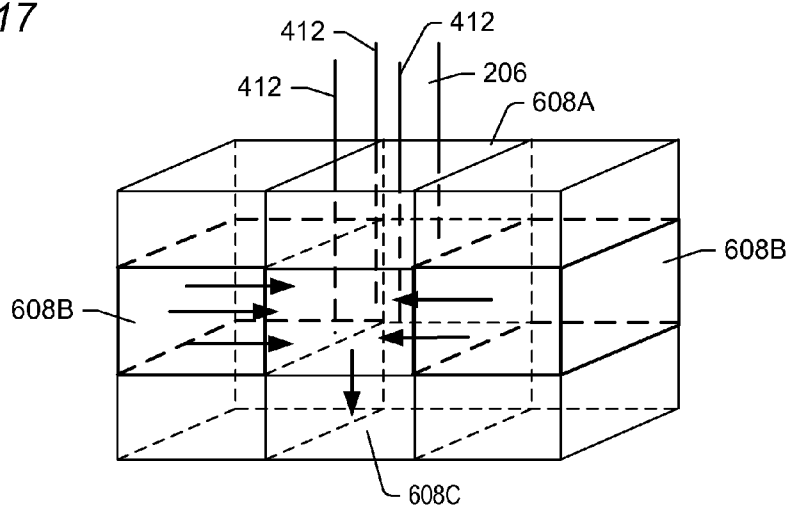

FIG. 118

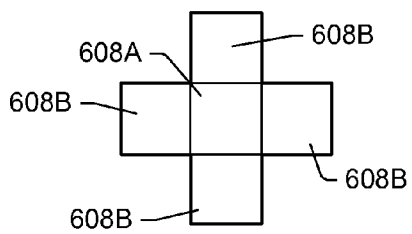

FIG. 119

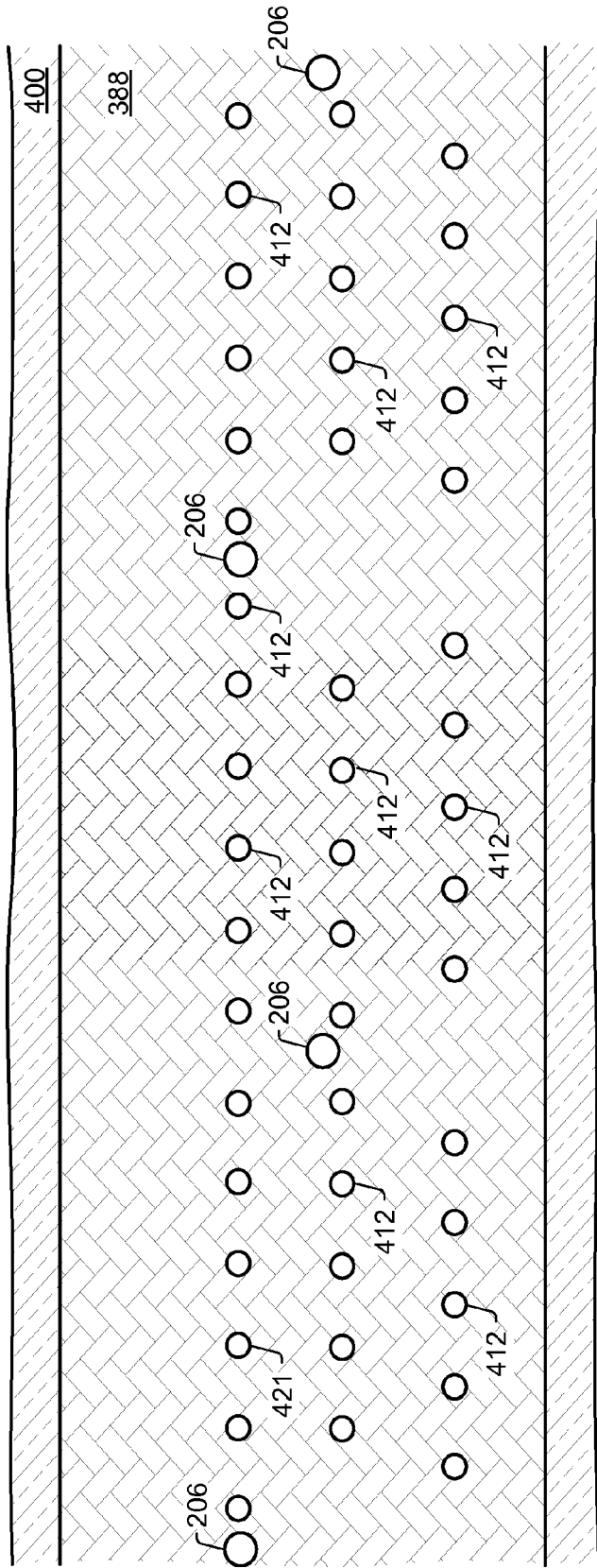

FIG. 120

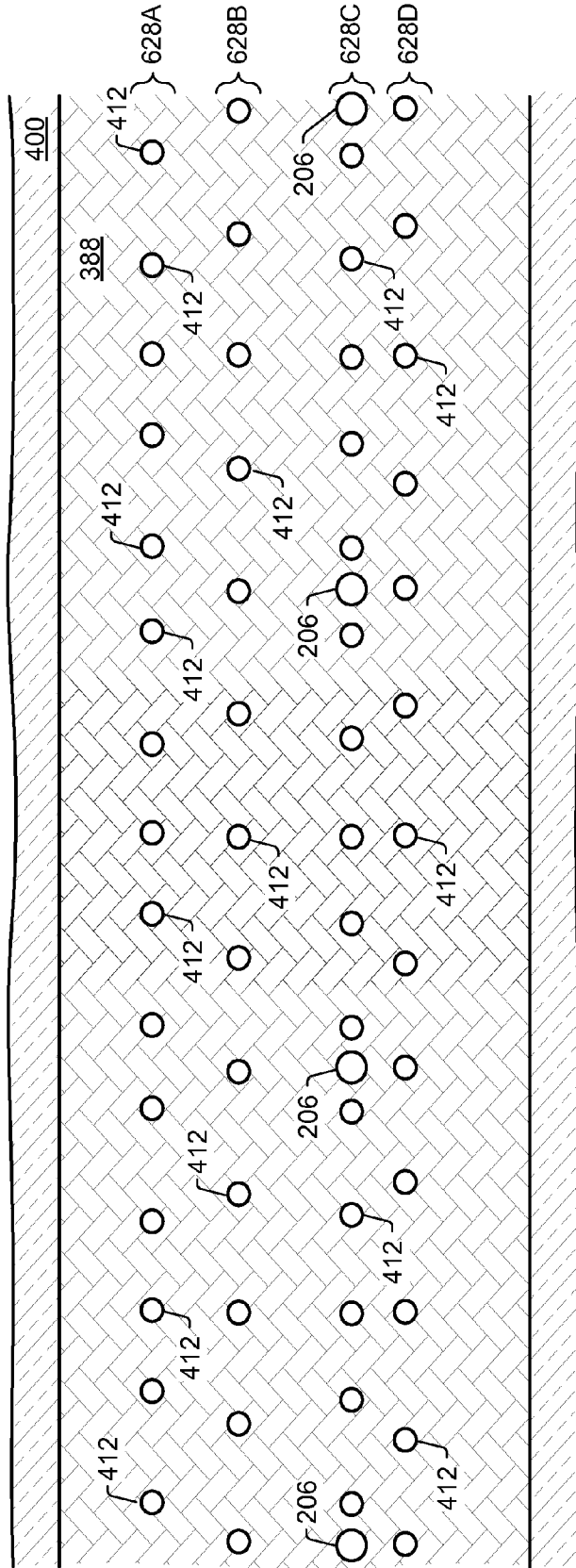

FIG. 121

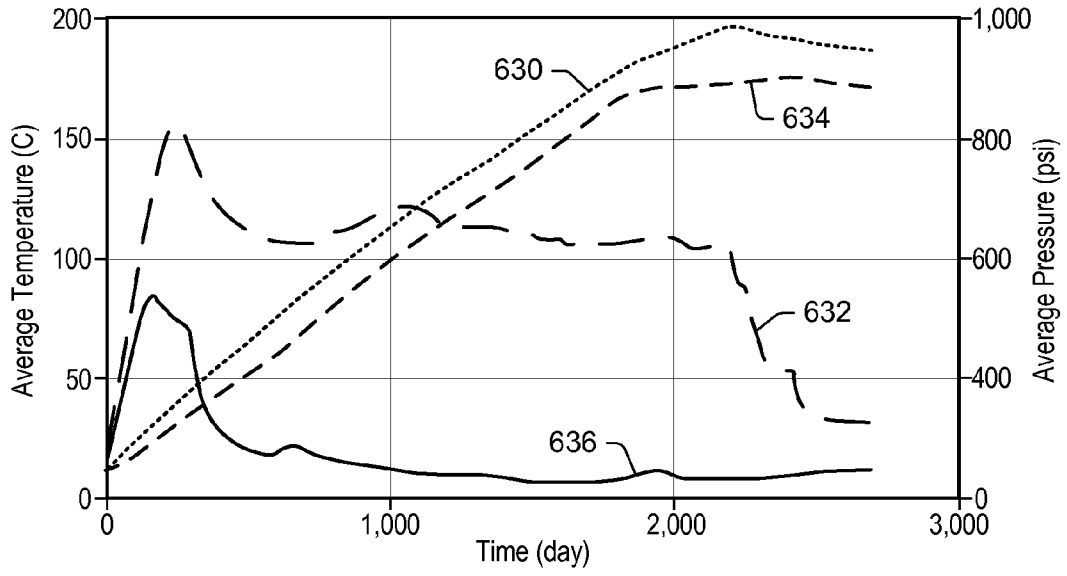

FIG. 122

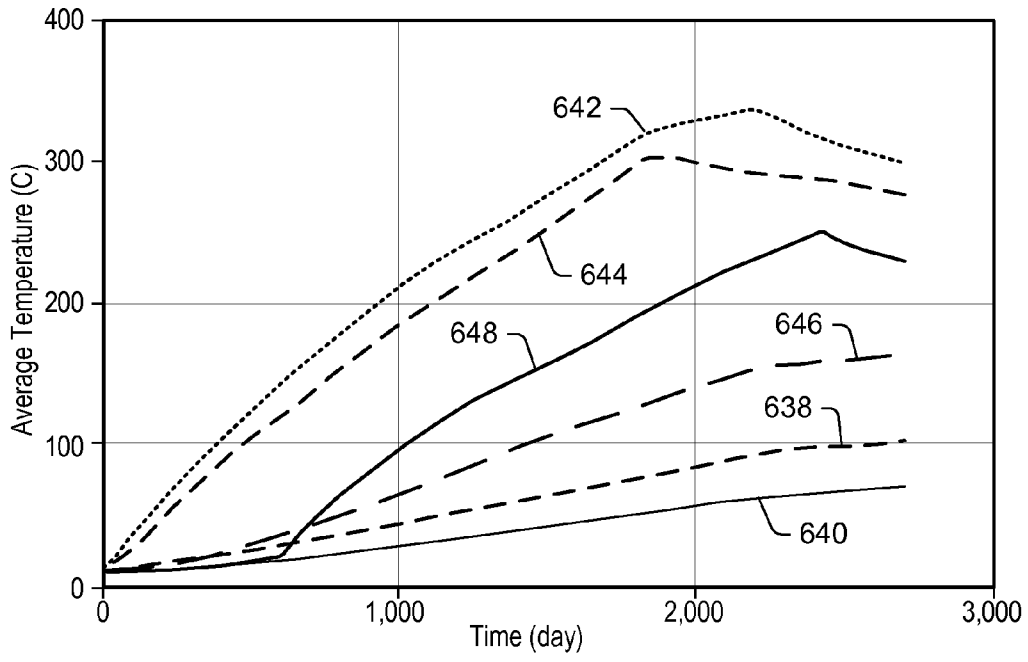

FIG. 123

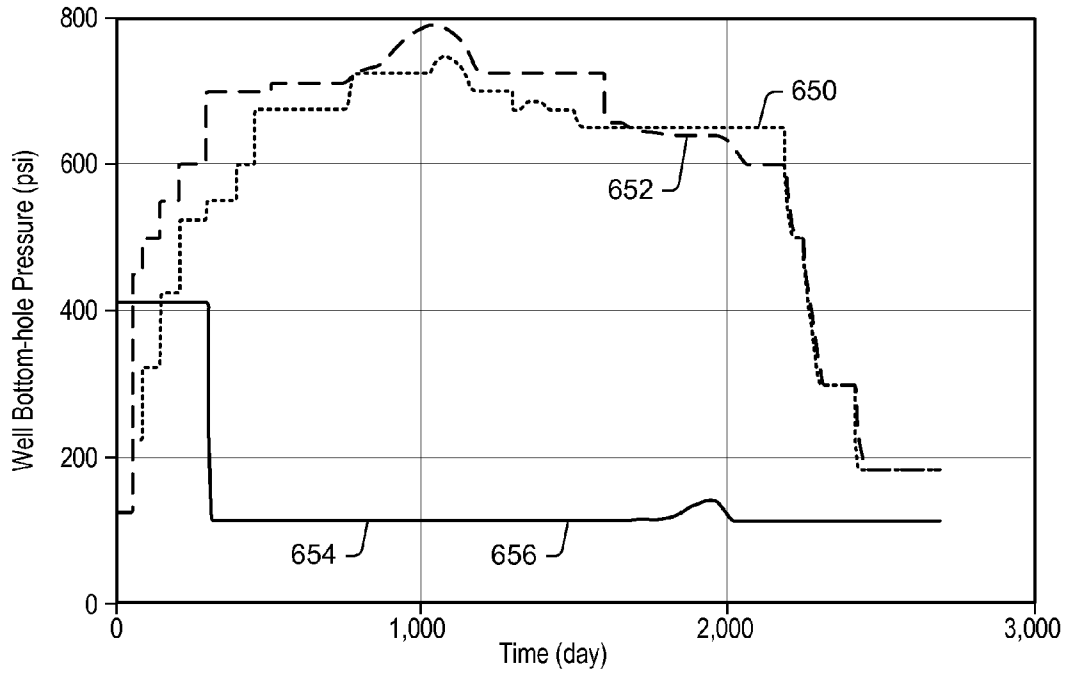

FIG. 124

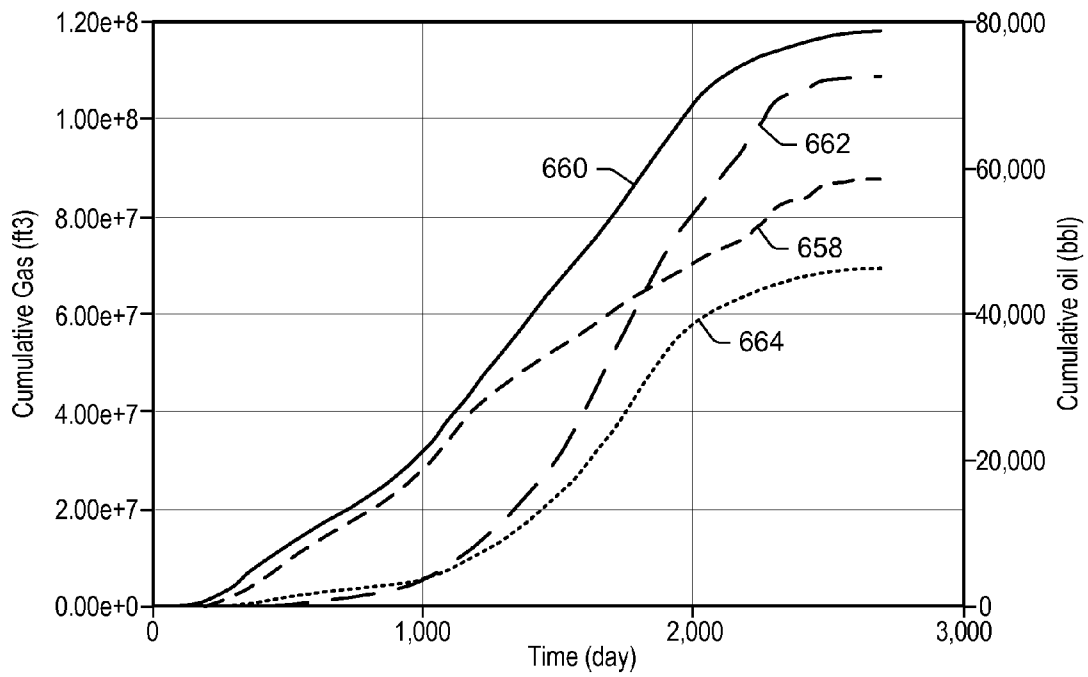

FIG. 125

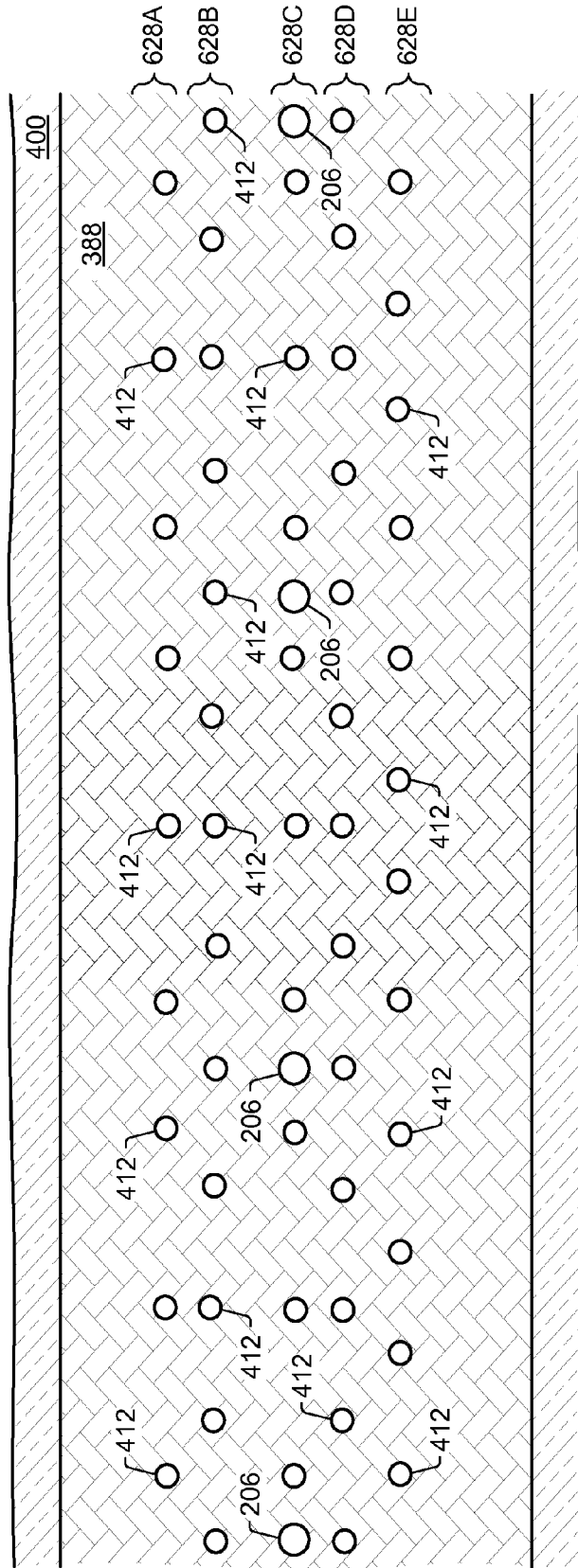

FIG. 126

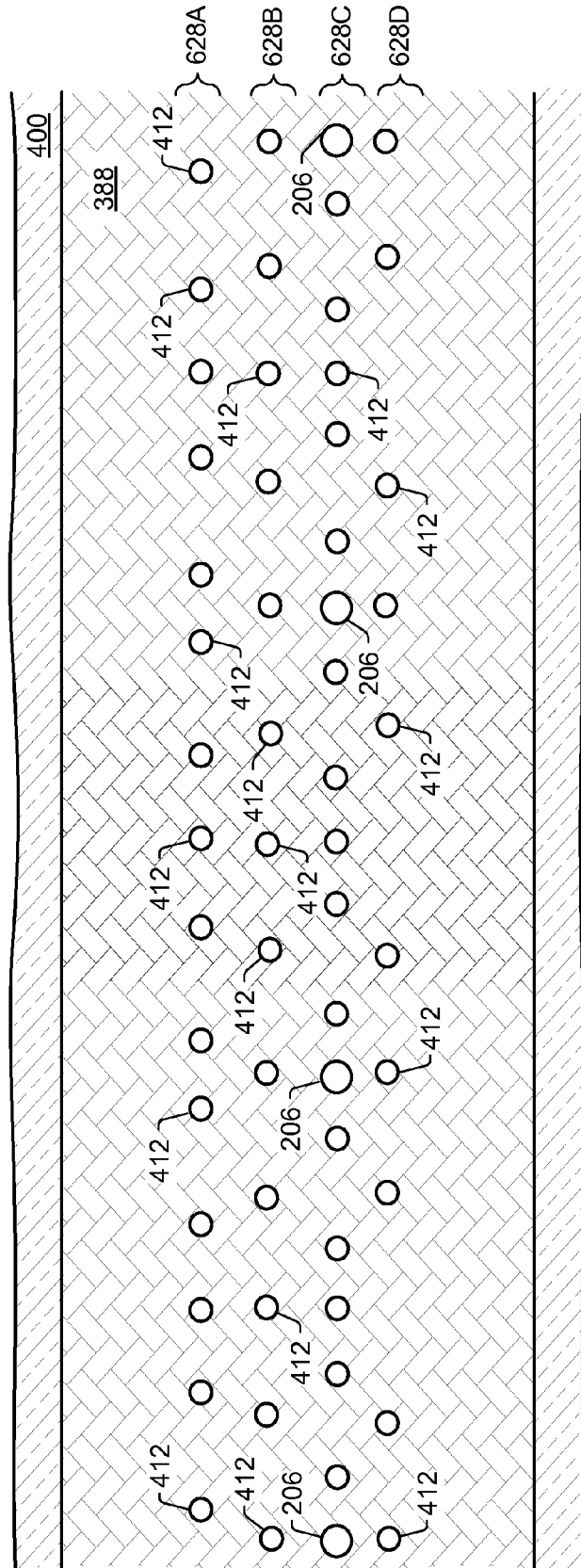

FIG. 127

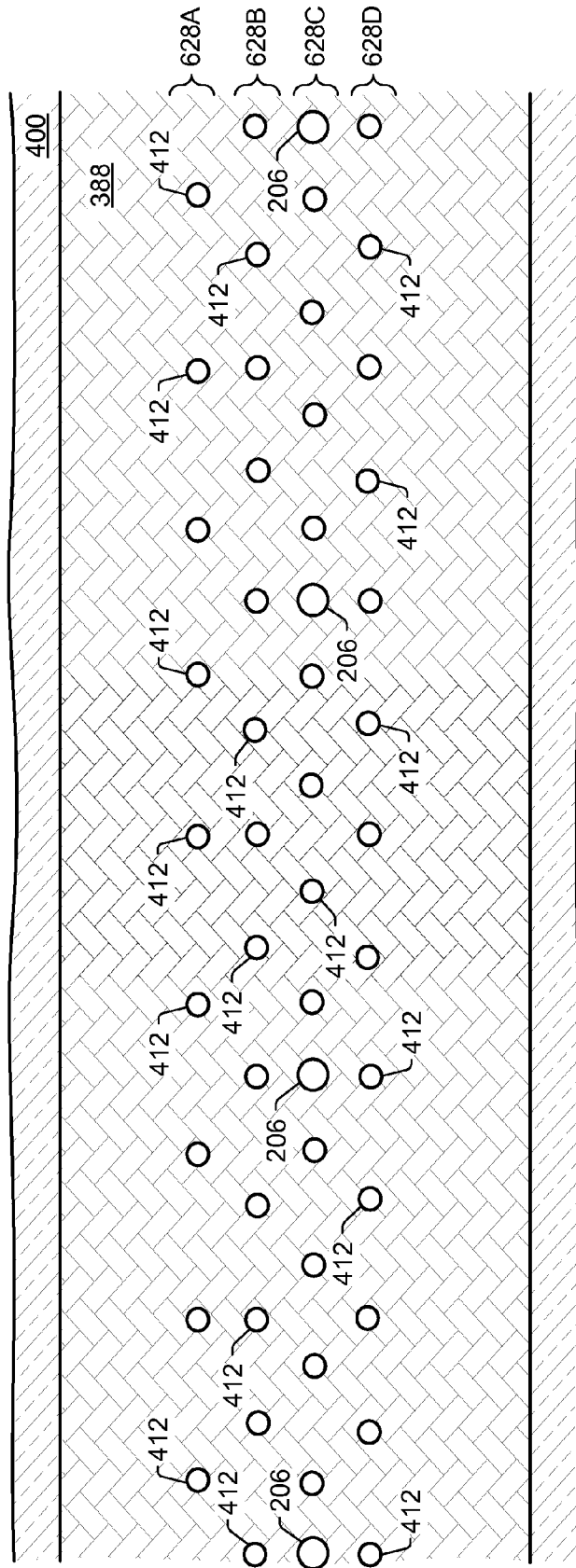

FIG. 128

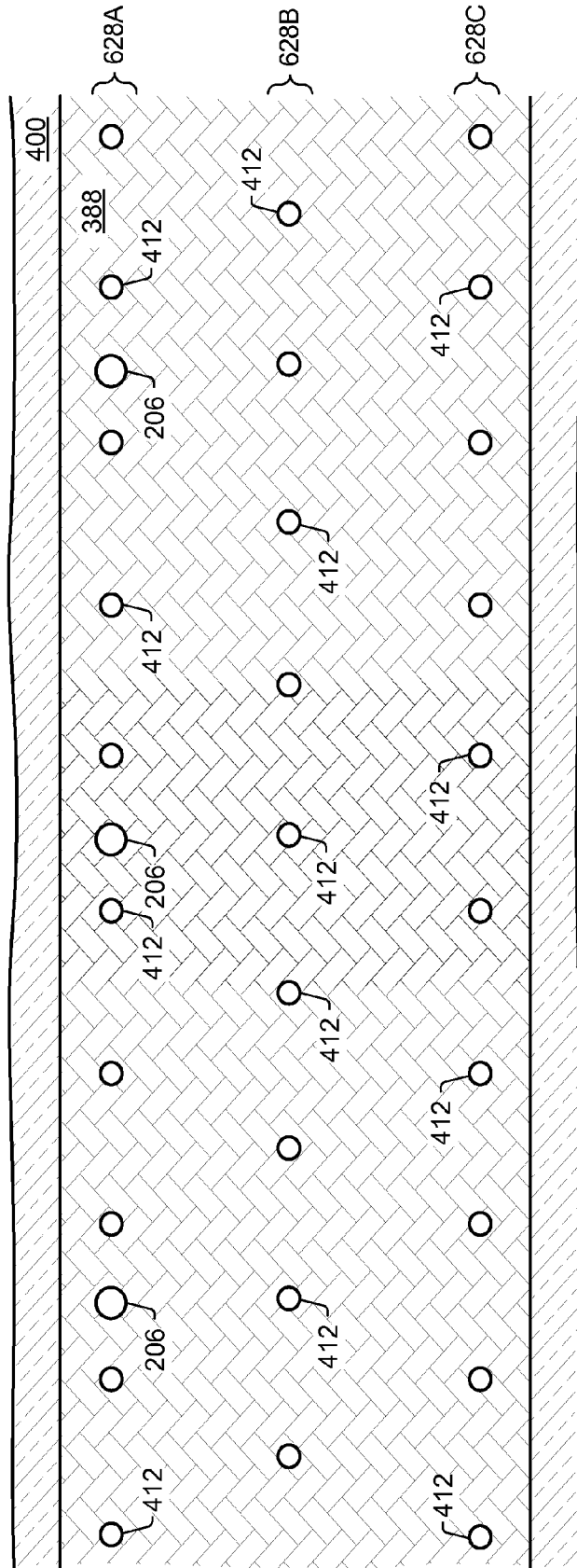

FIG. 129

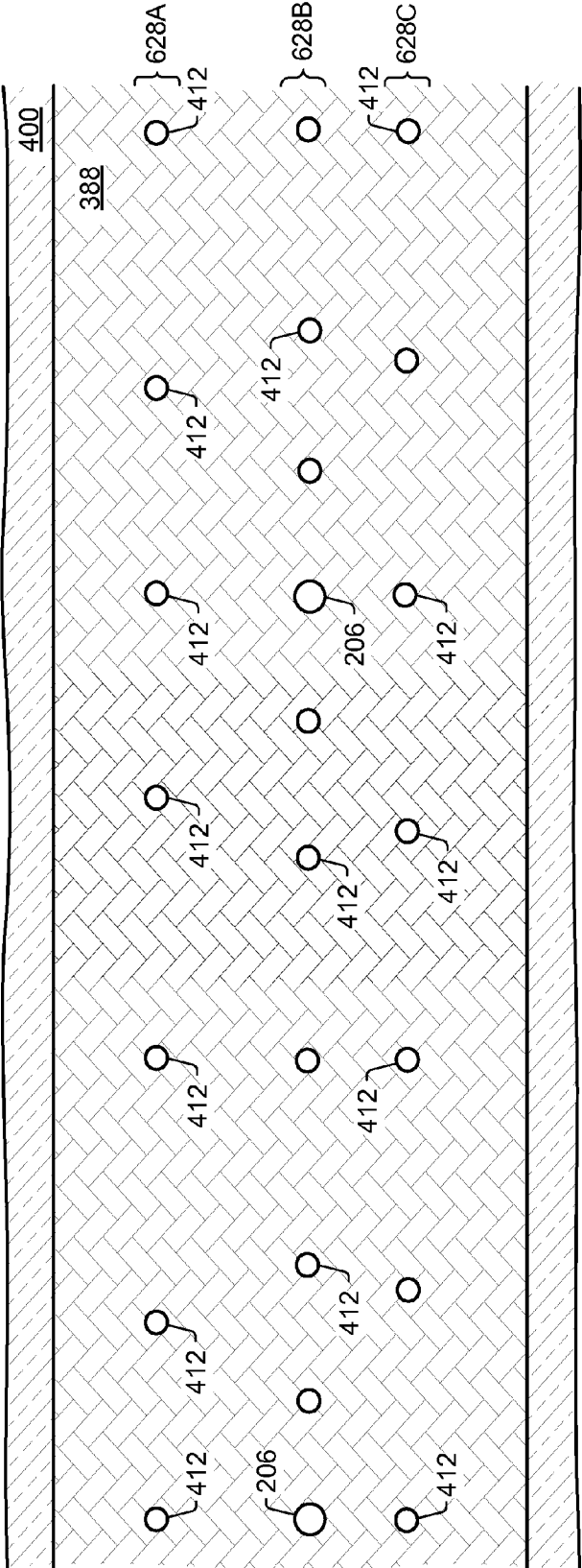

FIG. 130

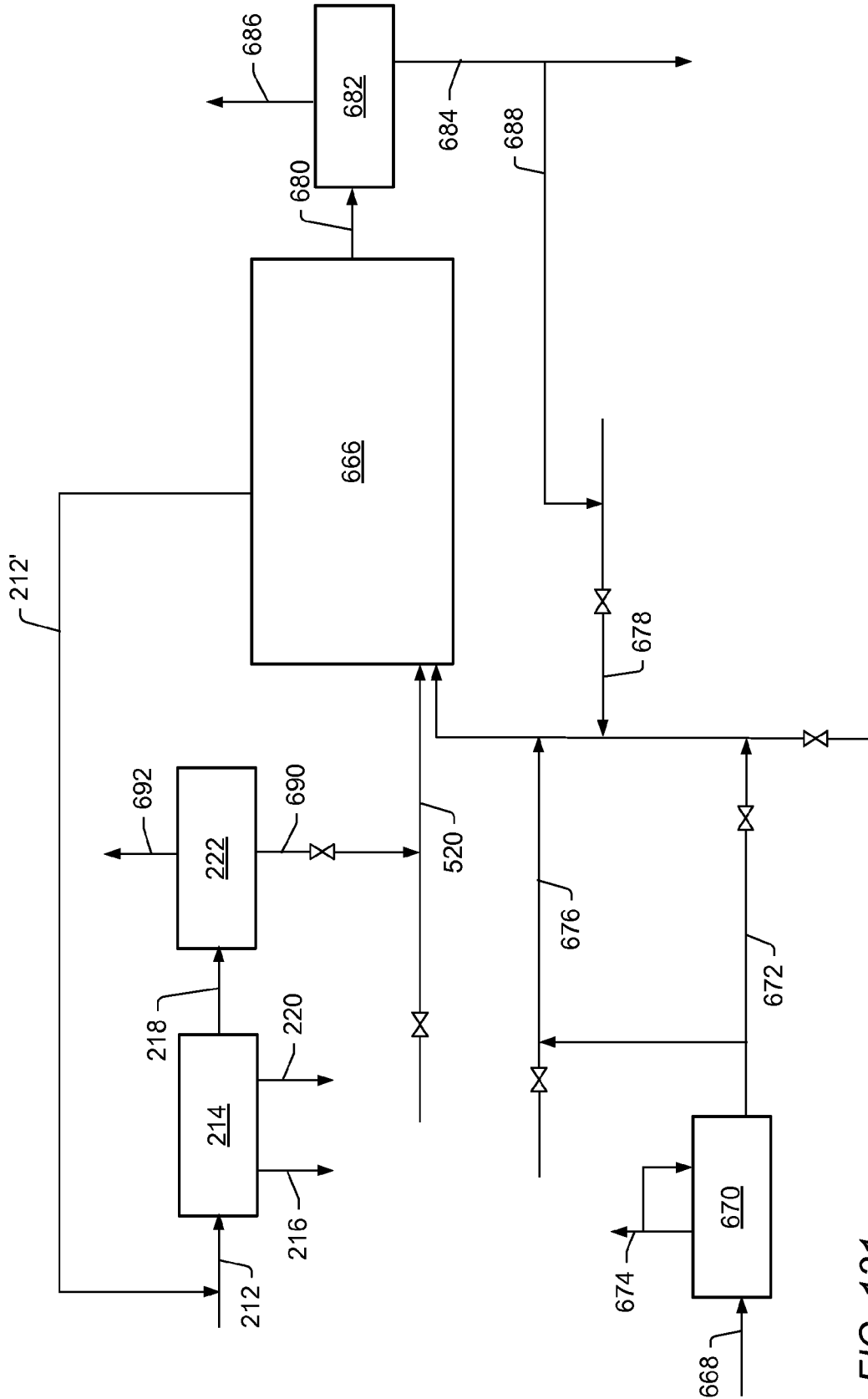

FIG. 131

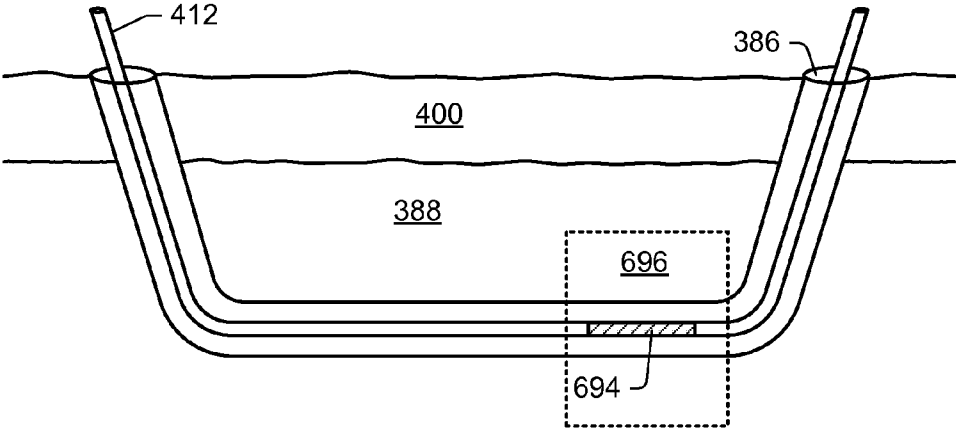

FIG. 132

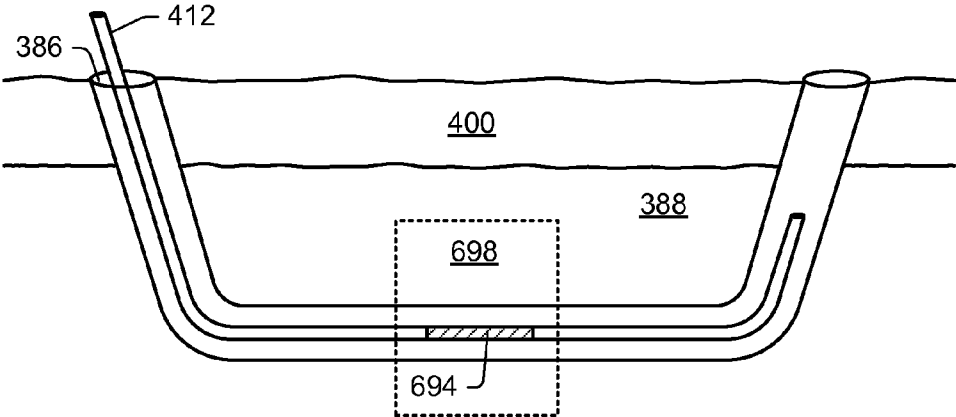

FIG. 133

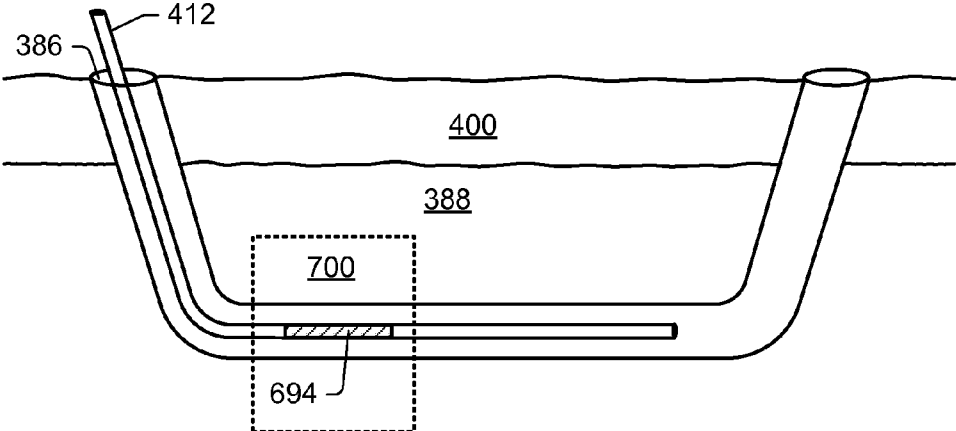

FIG. 134

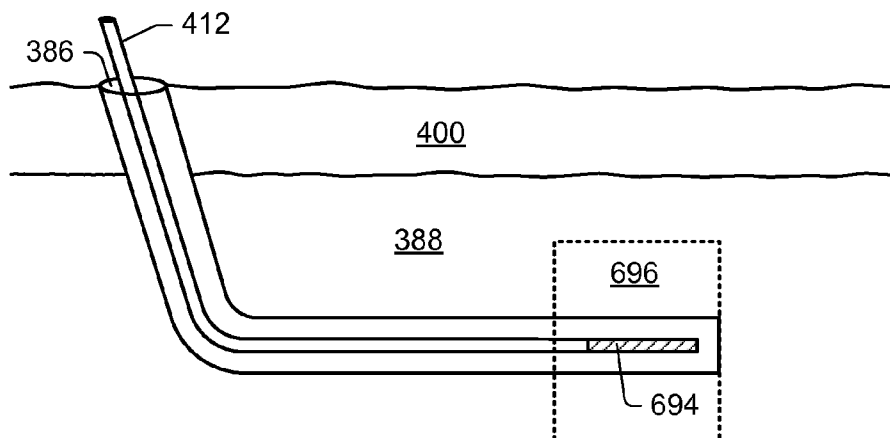

FIG. 135

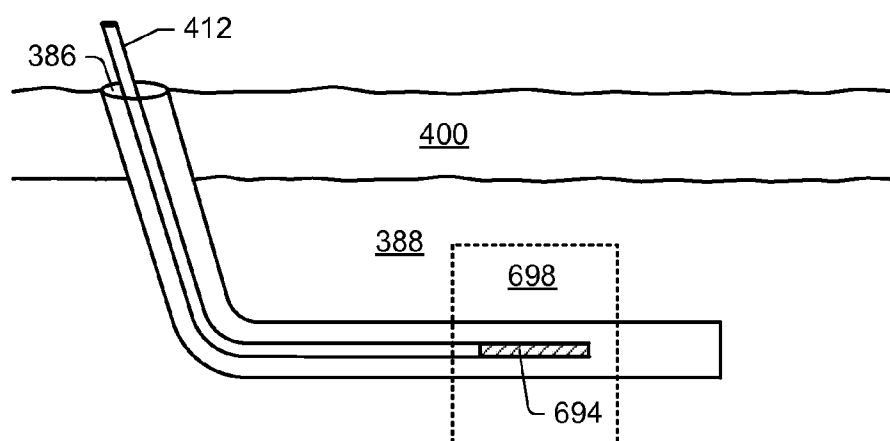

FIG. 136

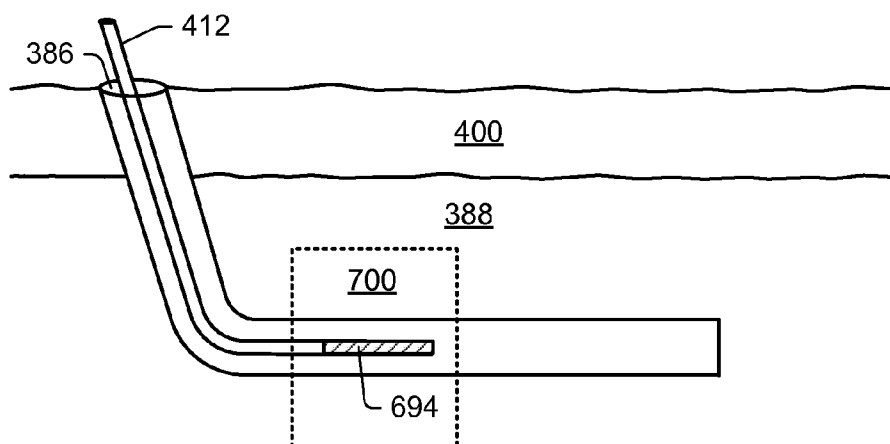

FIG. 137

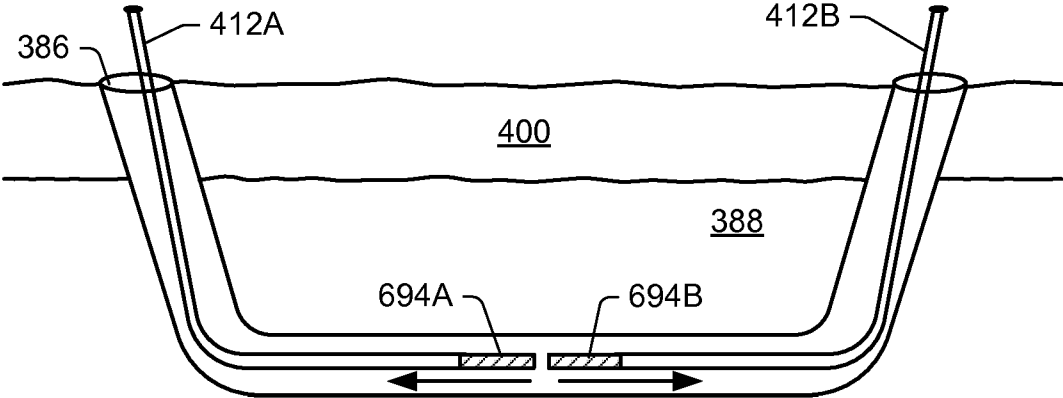

FIG. 138

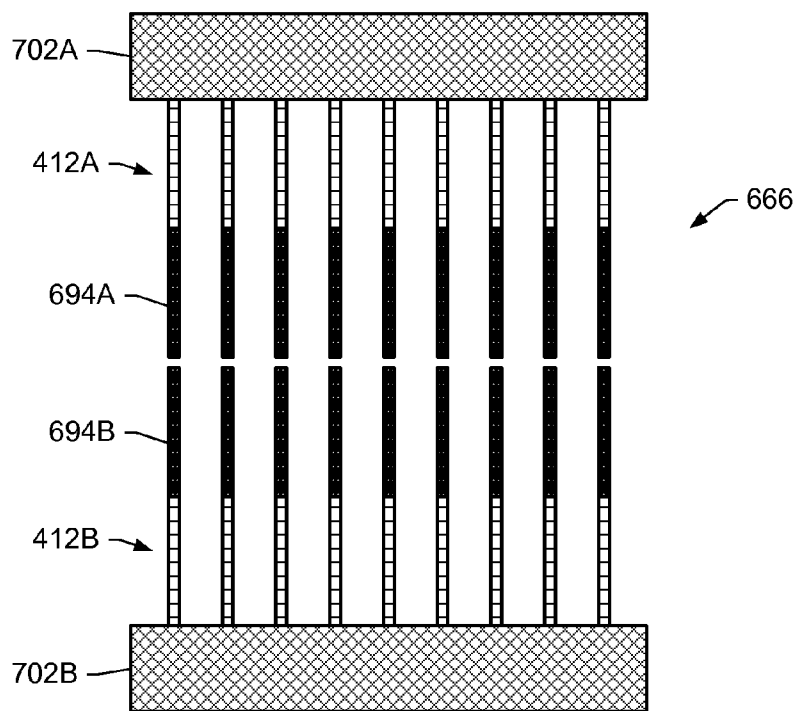

FIG. 139

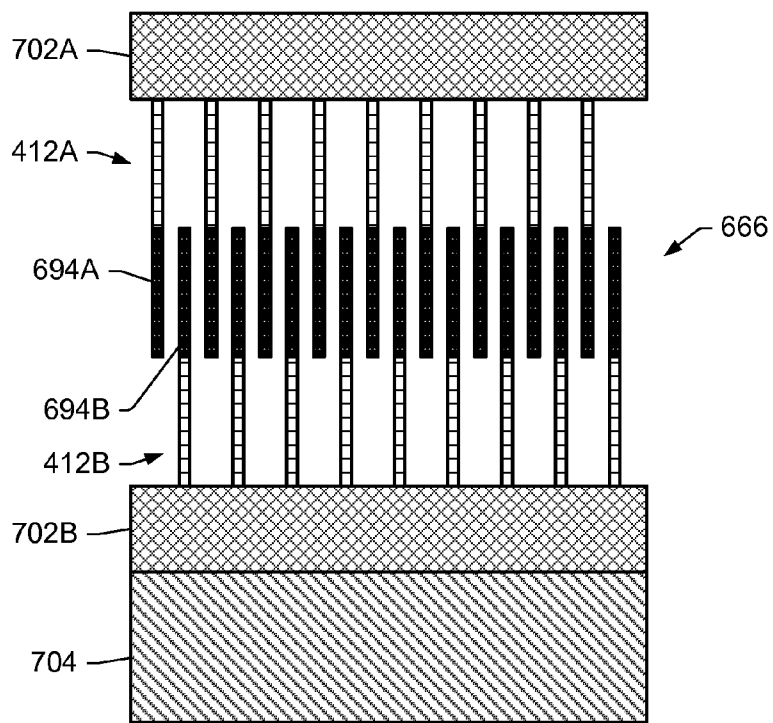

FIG. 140

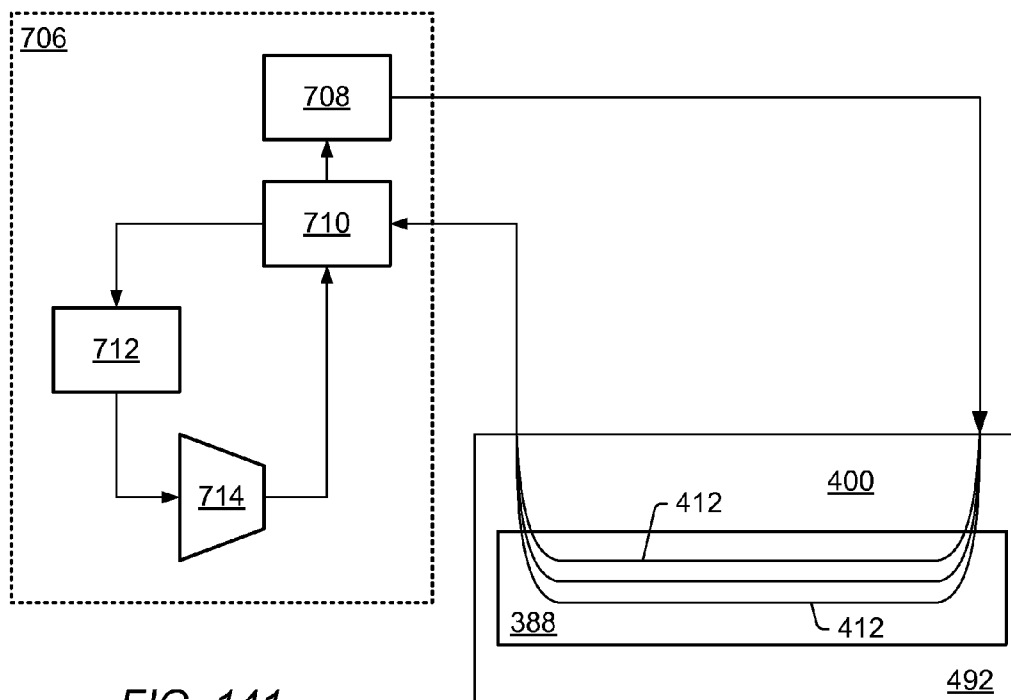

FIG. 141

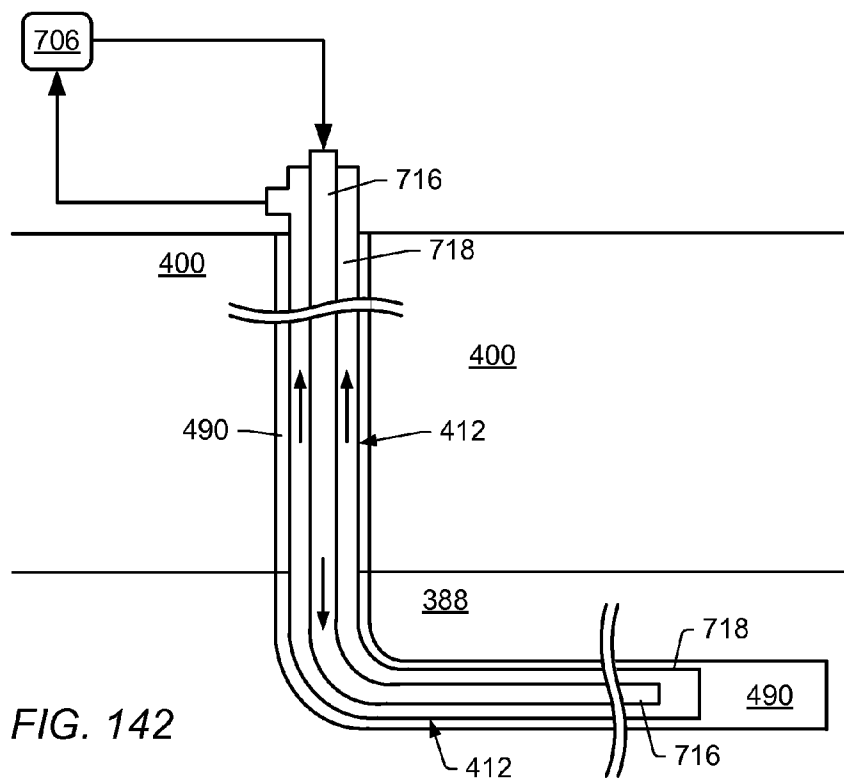

FIG. 142

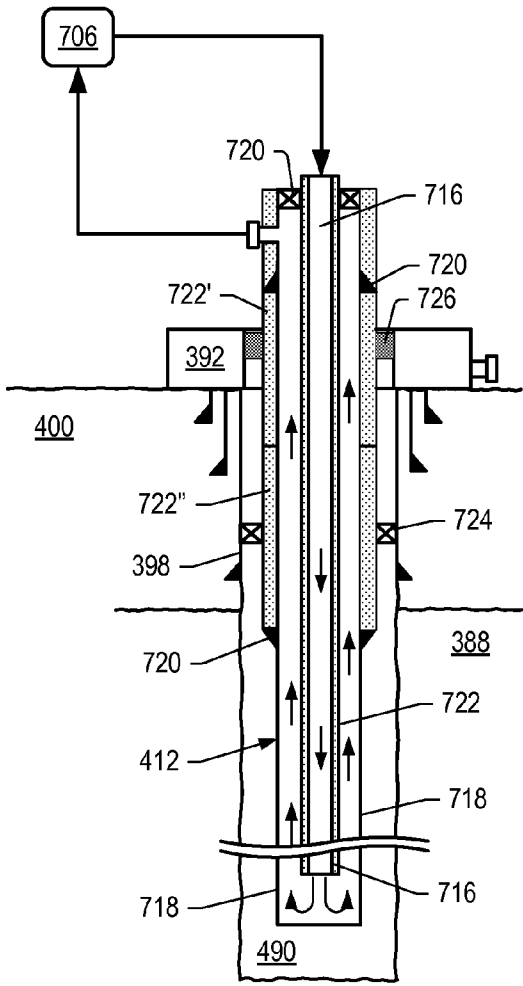

FIG. 143

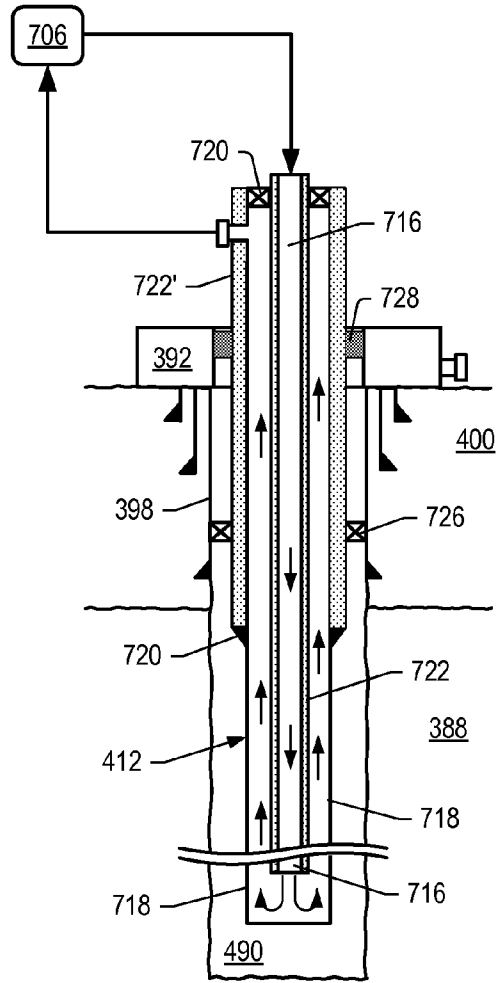

FIG. 144

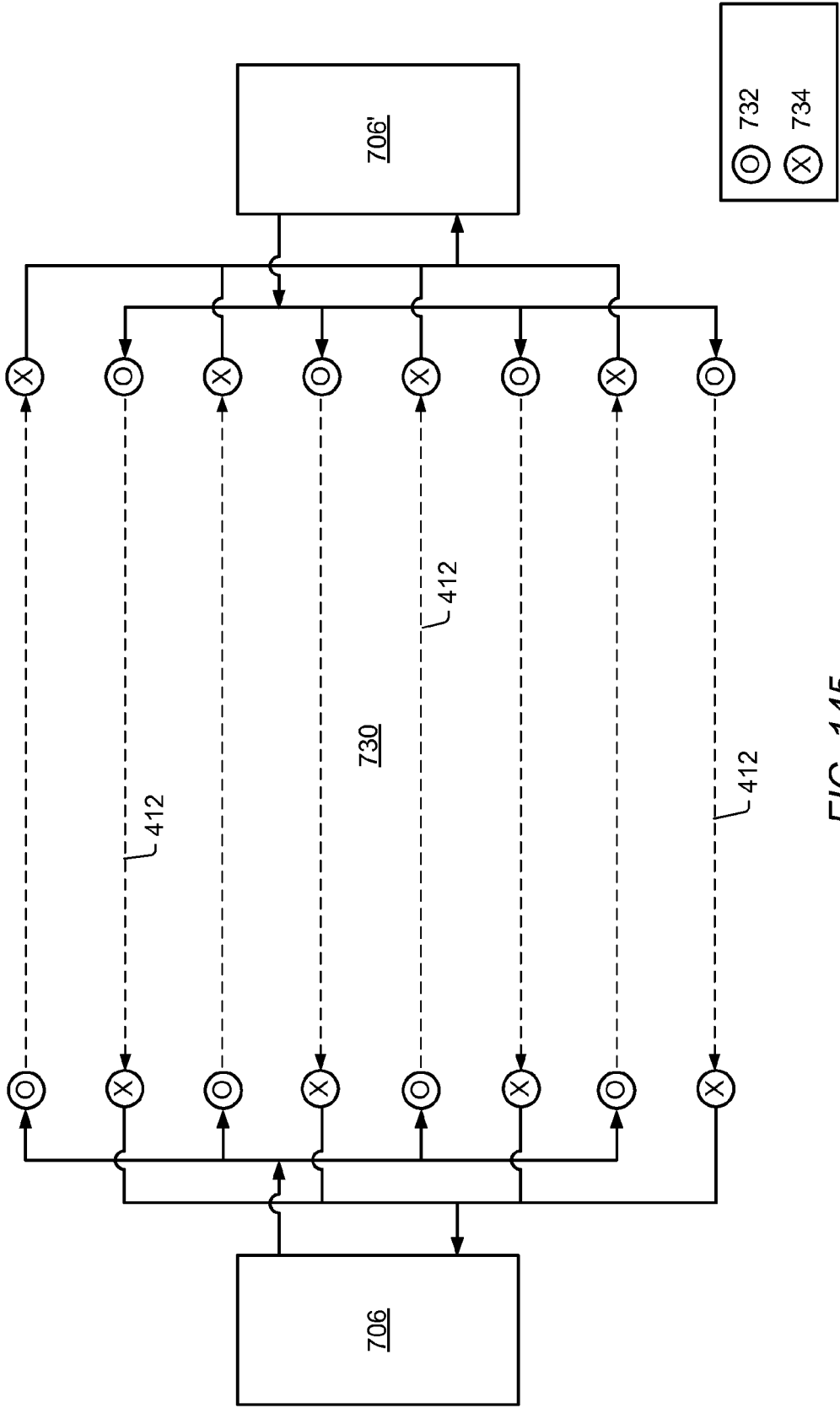

FIG. 145

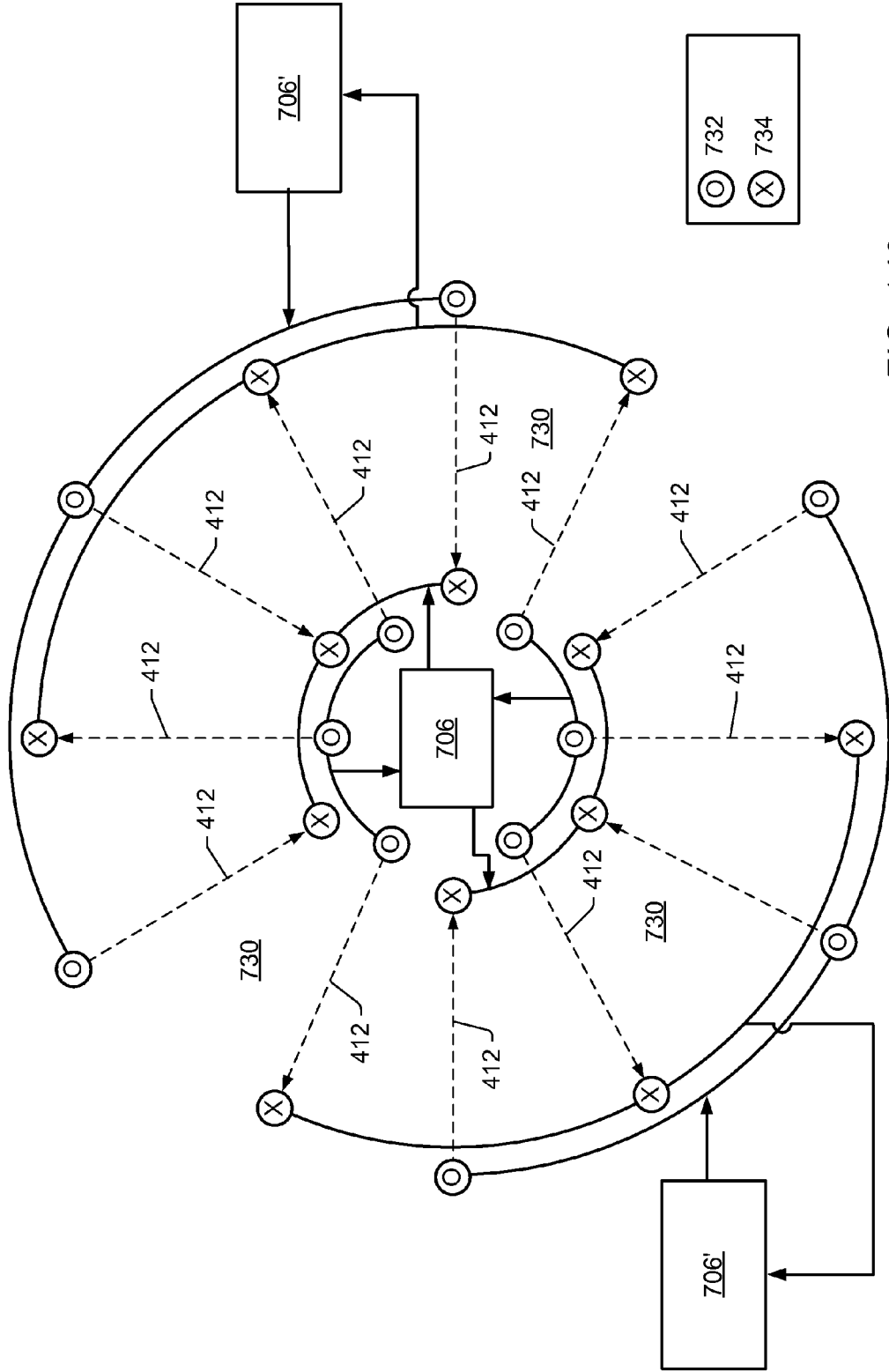
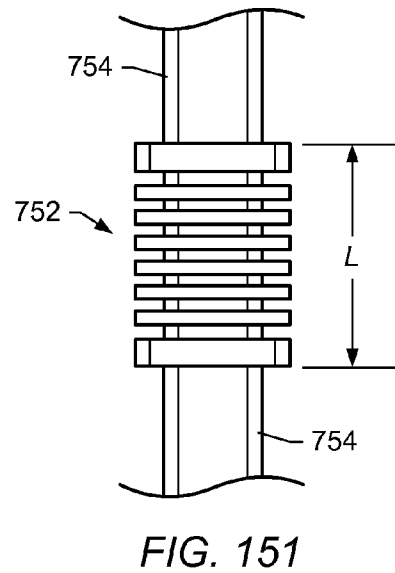
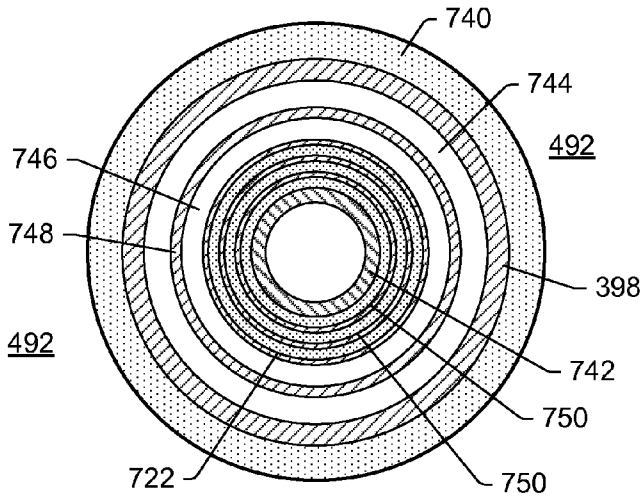
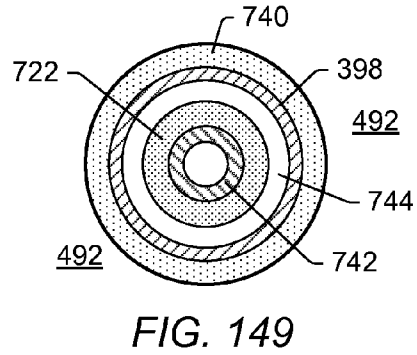
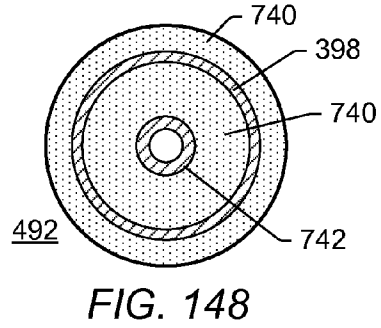
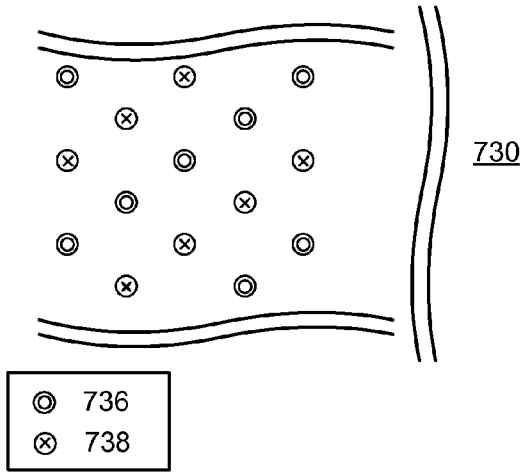

FIG. 146



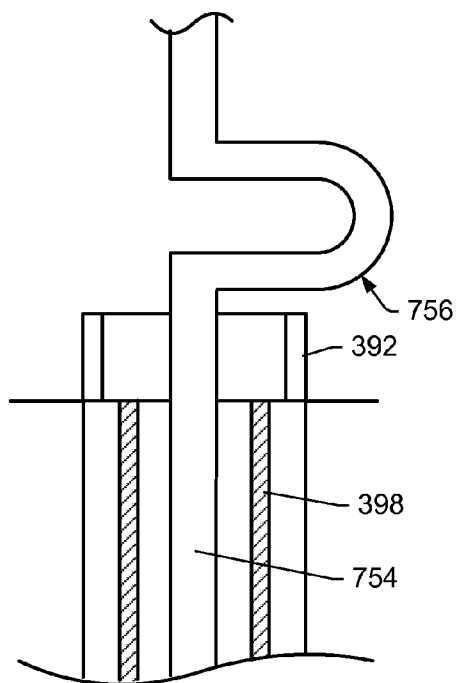

FIG. 152A

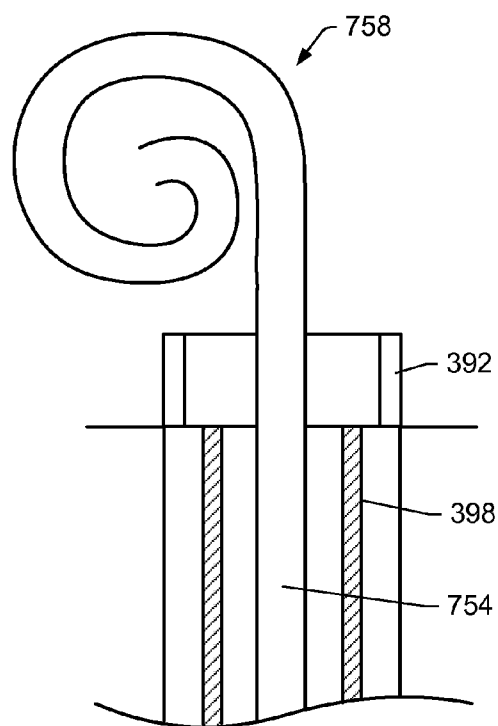

FIG. 152B

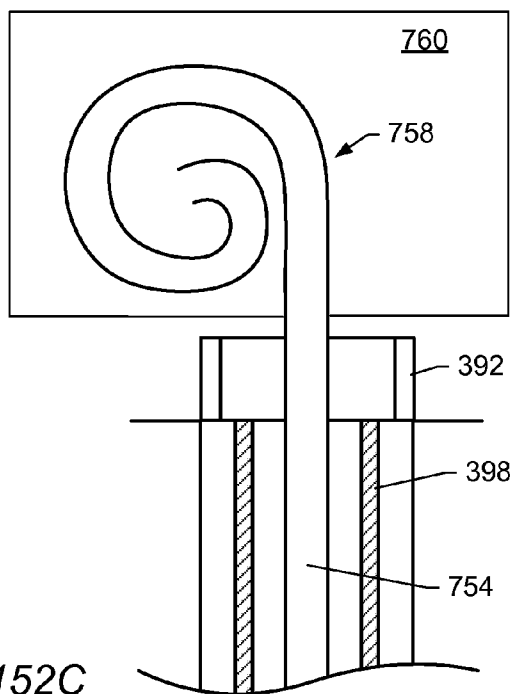

FIG. 152C

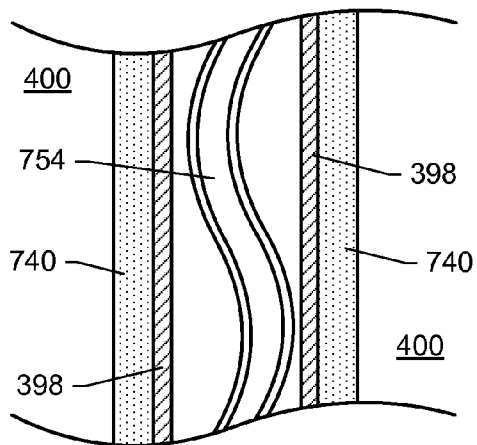

FIG. 153

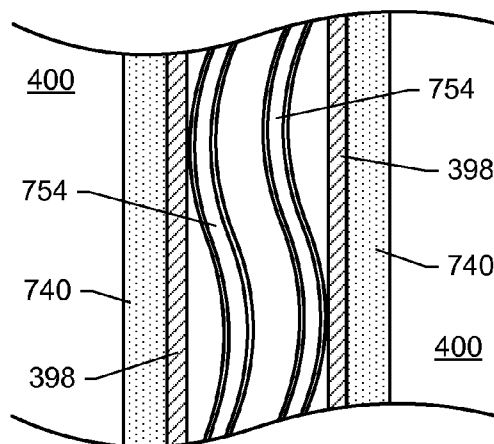

FIG. 154

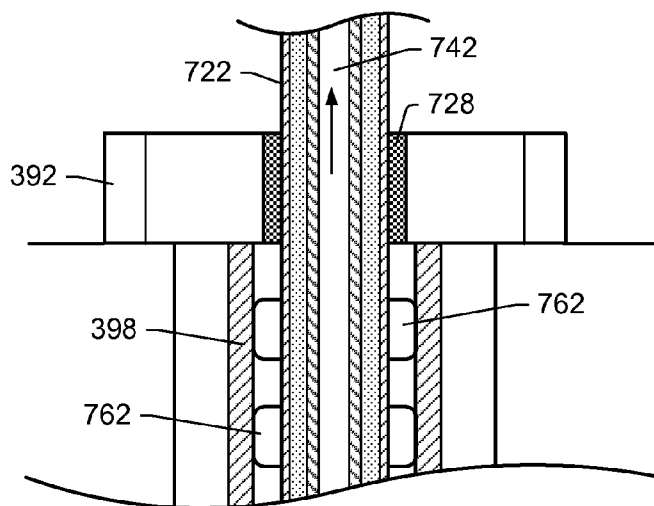

FIG. 155

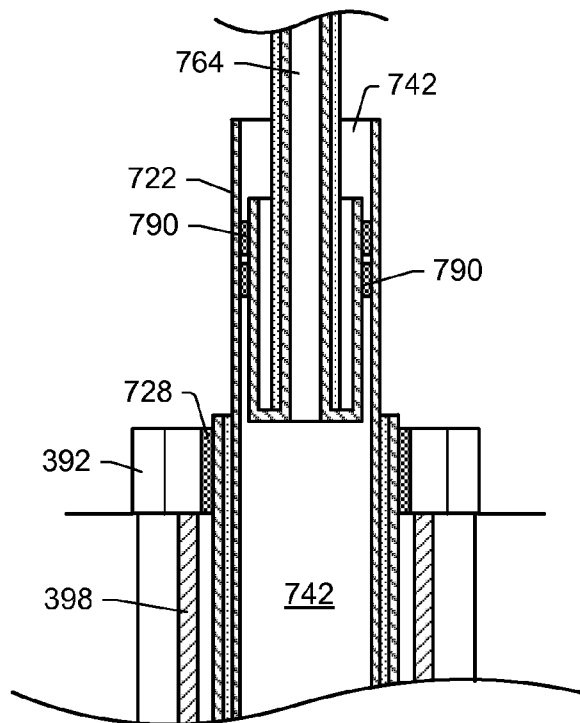

FIG. 156

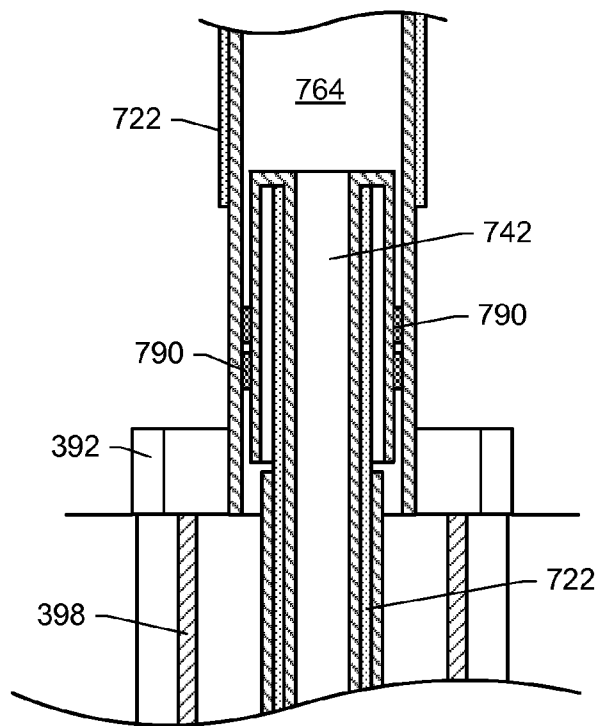

FIG. 157

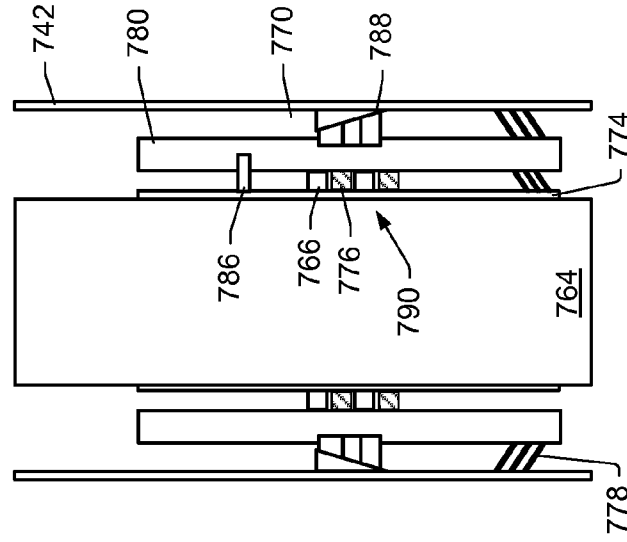

FIG. 160

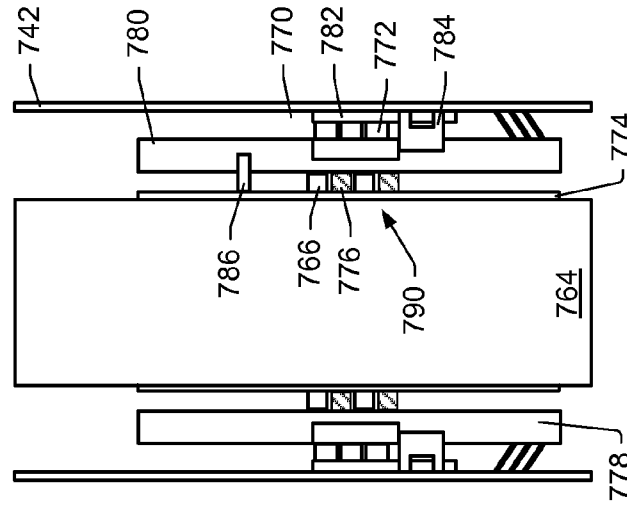

FIG. 159

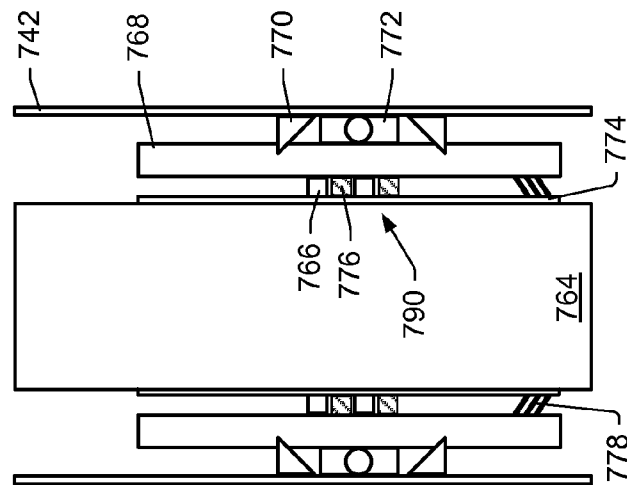

FIG. 158

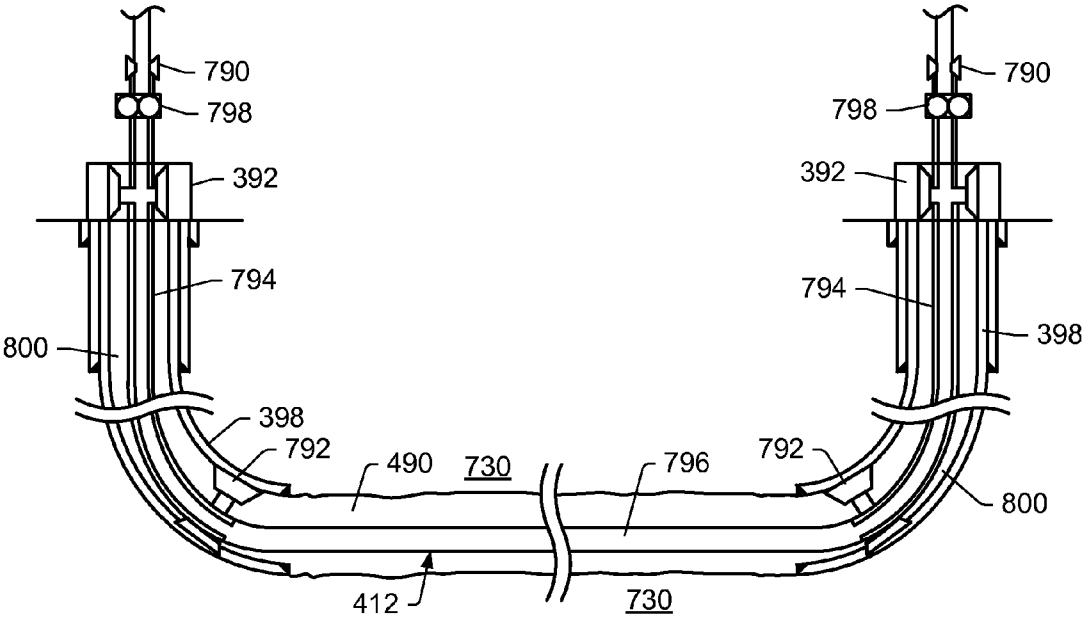

FIG. 161

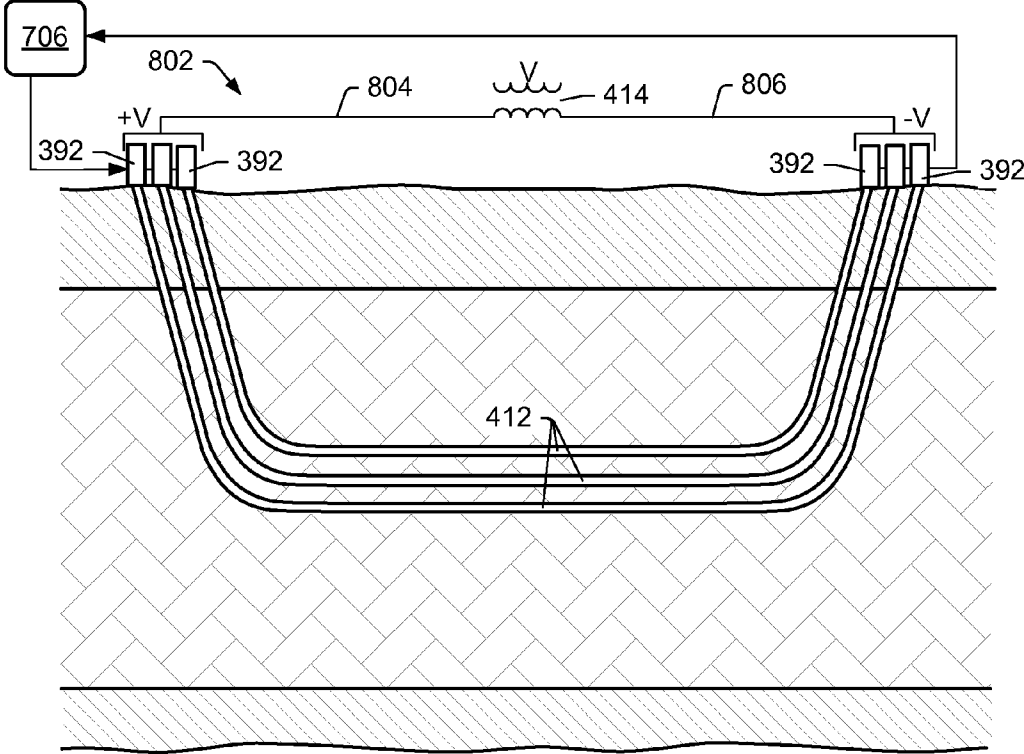

FIG. 162

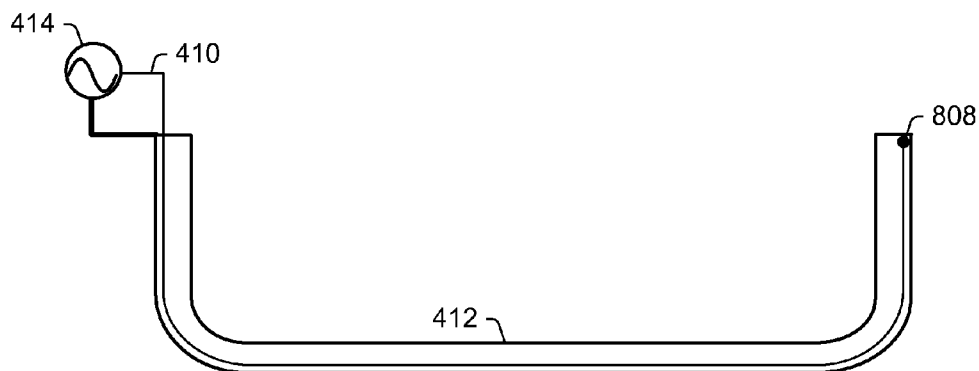

FIG. 163

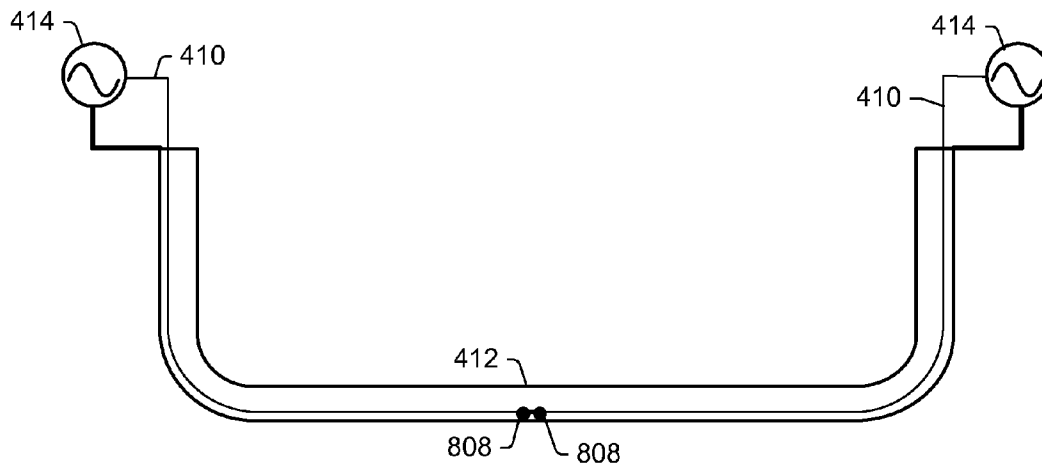

FIG. 164

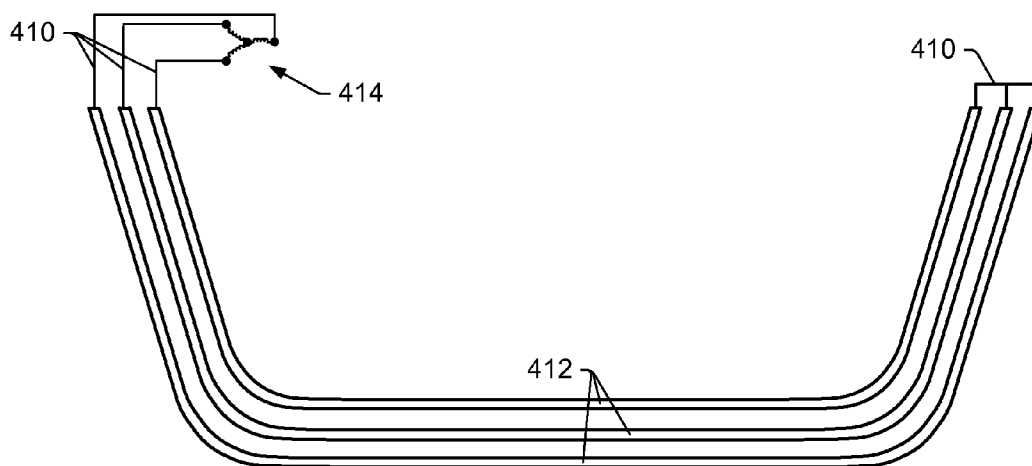

FIG. 165

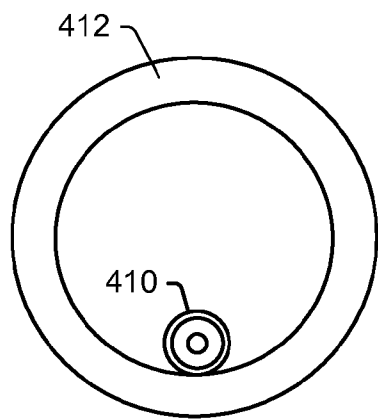

FIG. 166

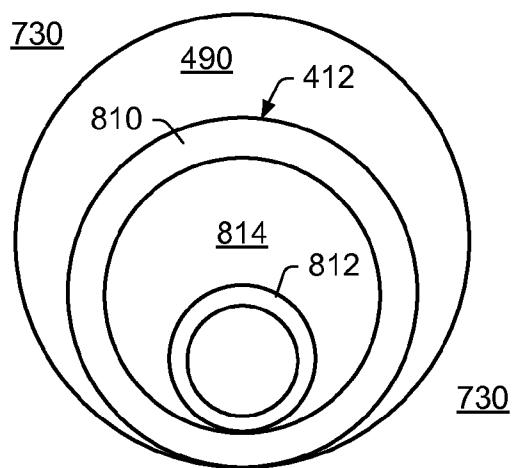

FIG. 167

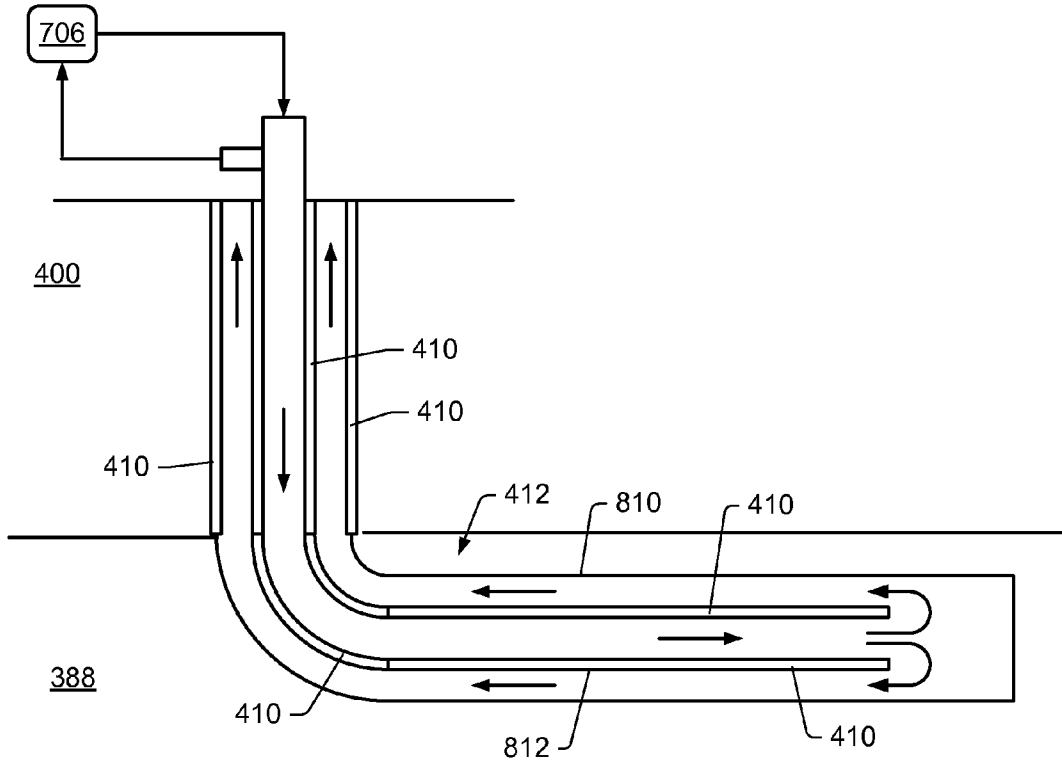

FIG. 168

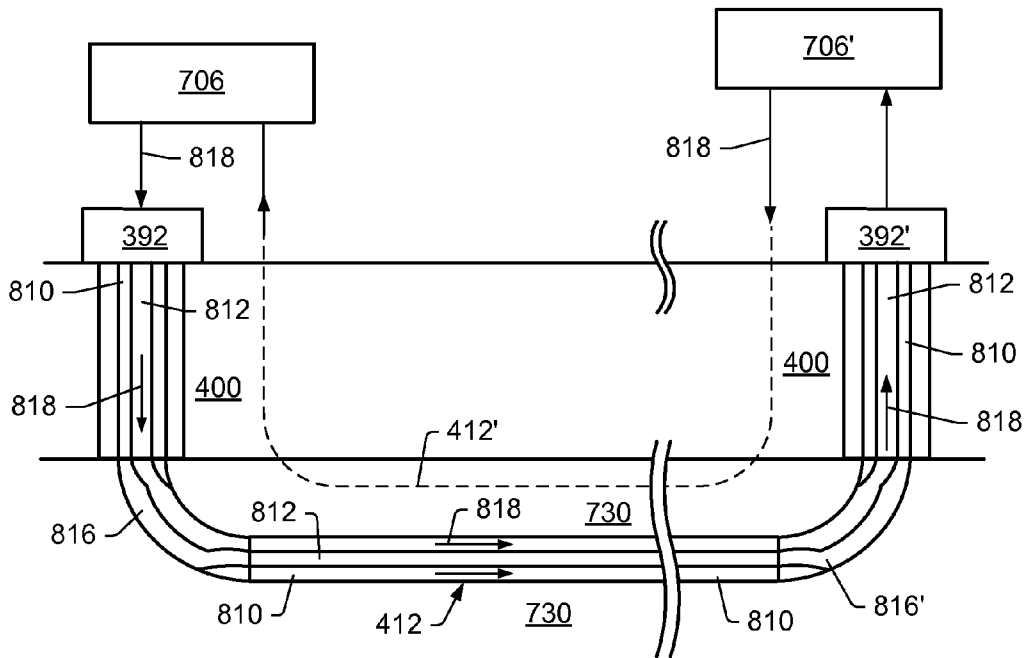

FIG. 169

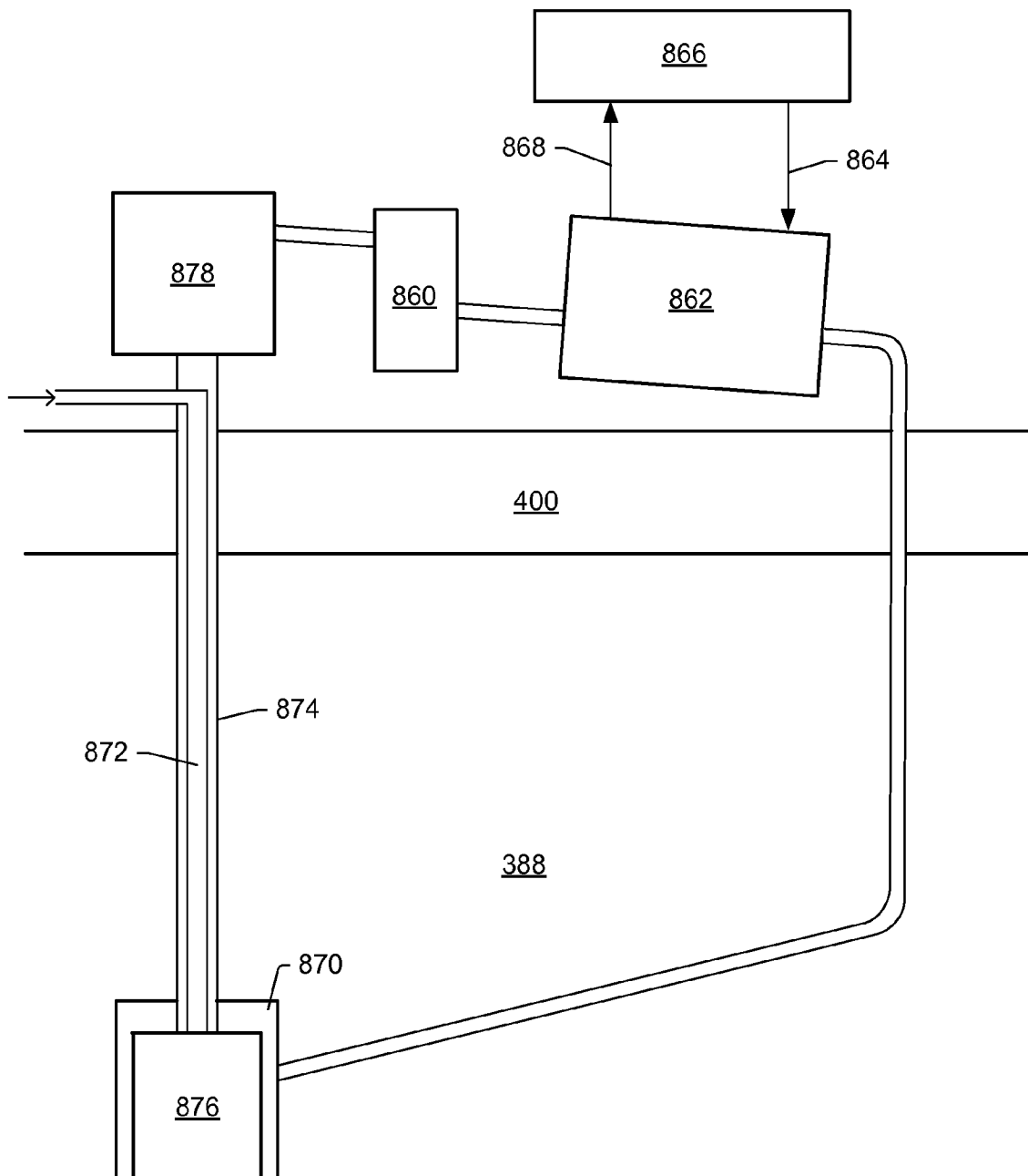

FIG. 172

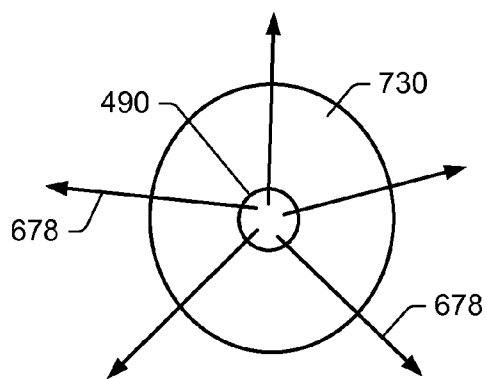

FIG. 173

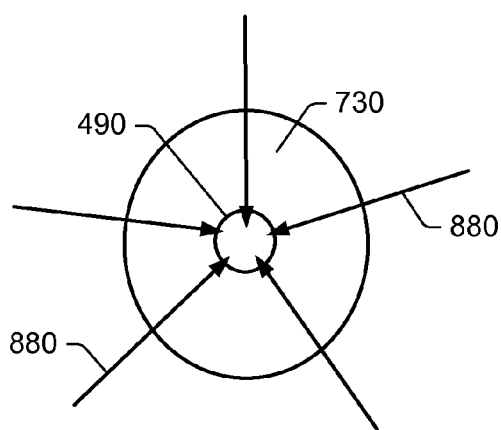

FIG. 174

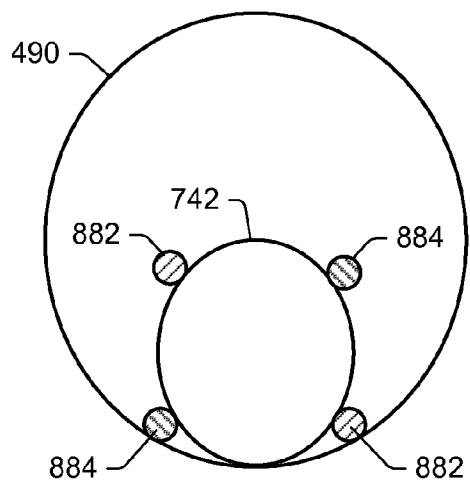

FIG. 175

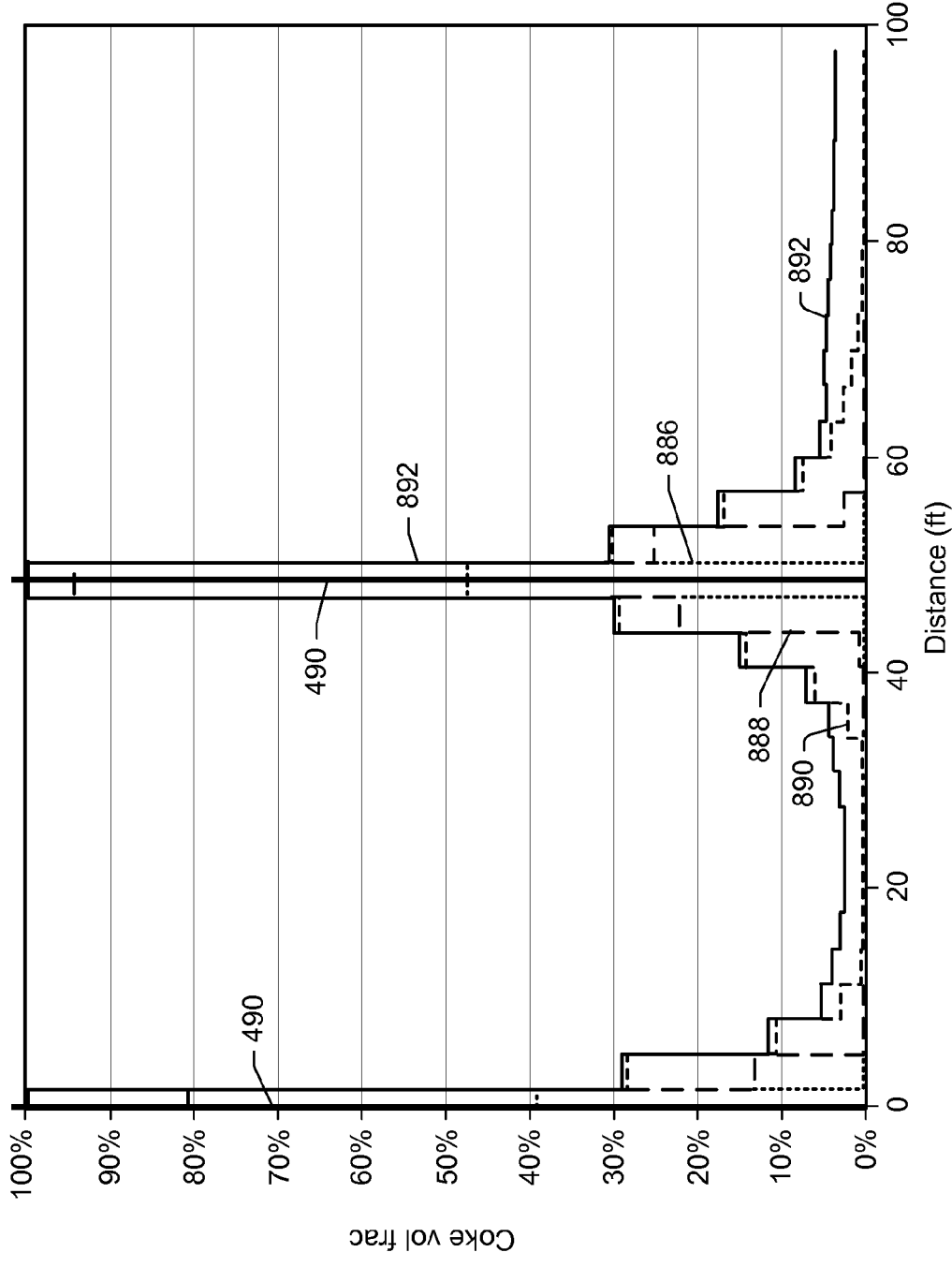

FIG. 176

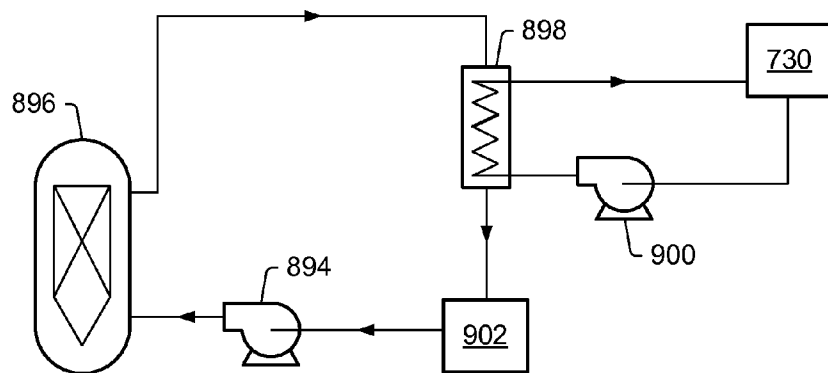

FIG. 177

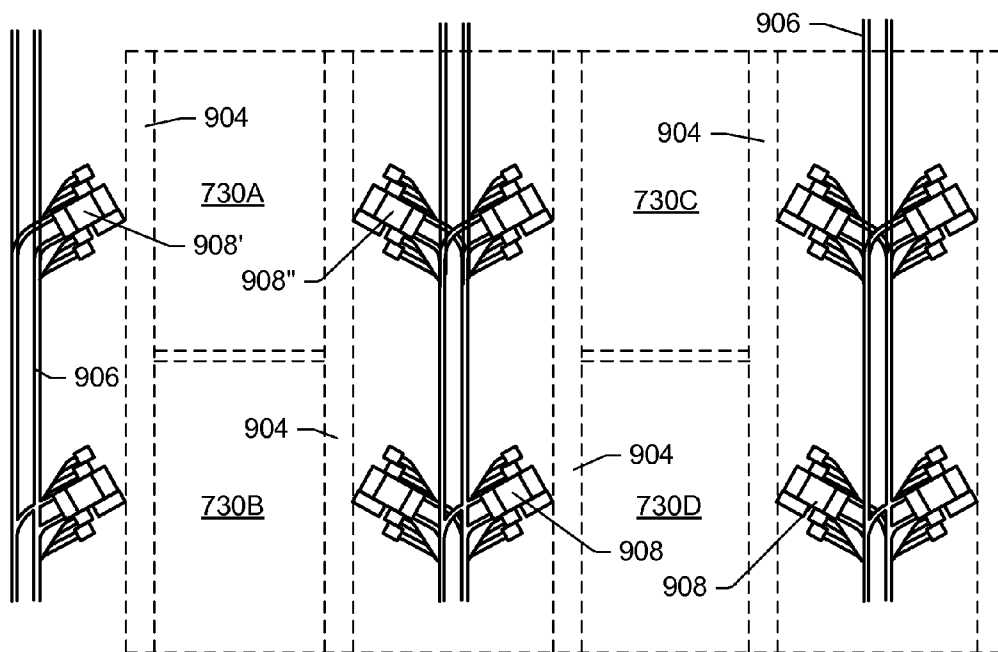

FIG. 178

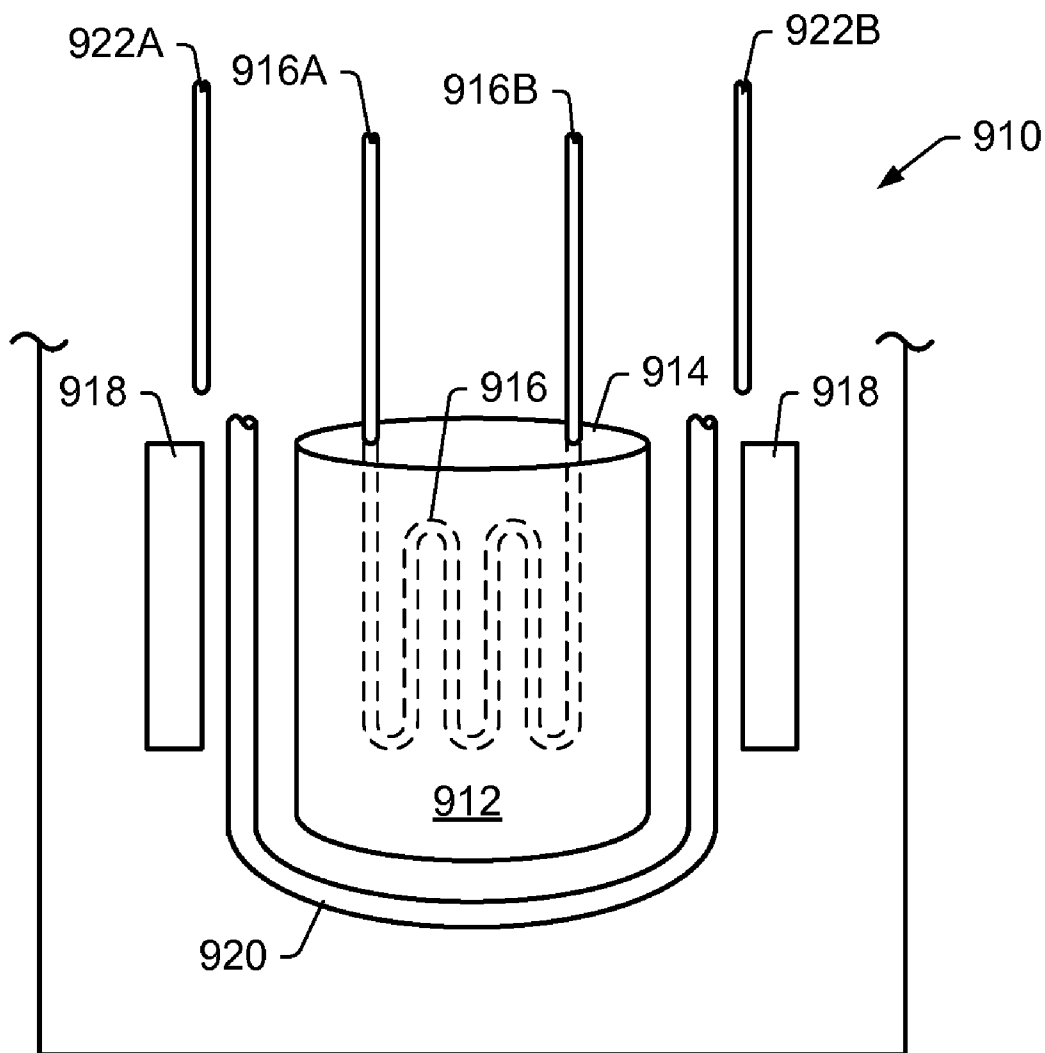

FIG. 179

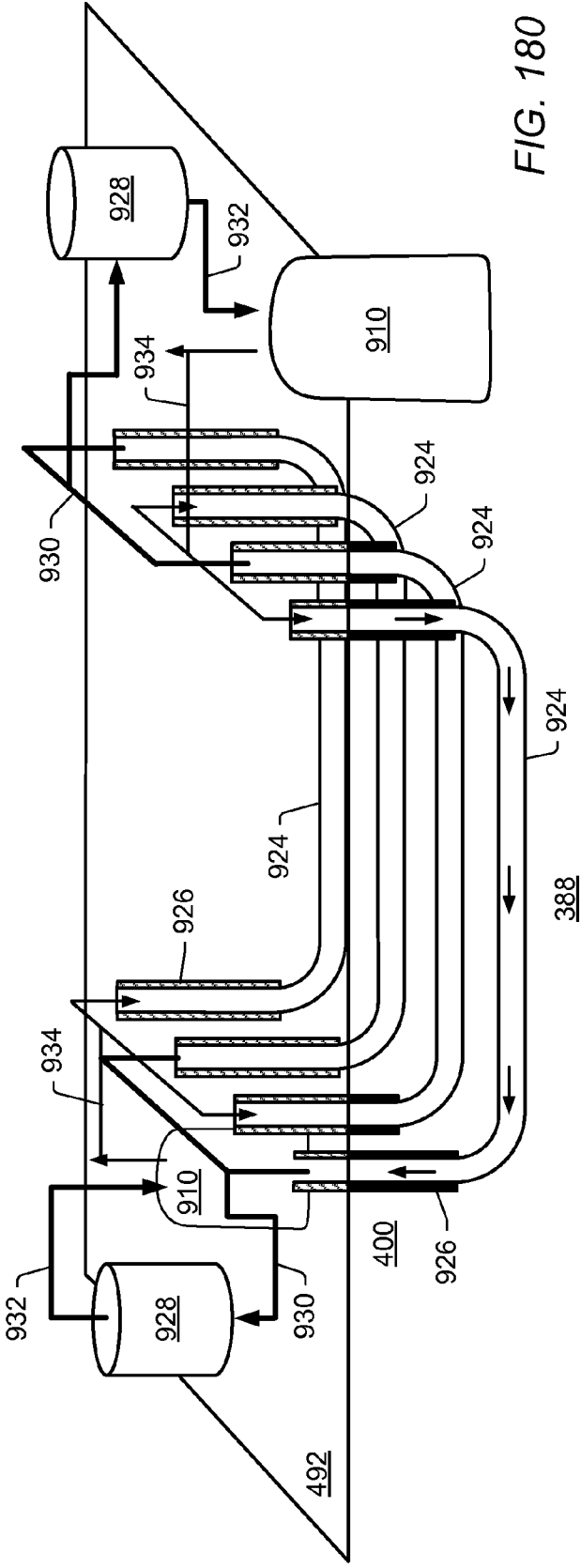

FIG. 180

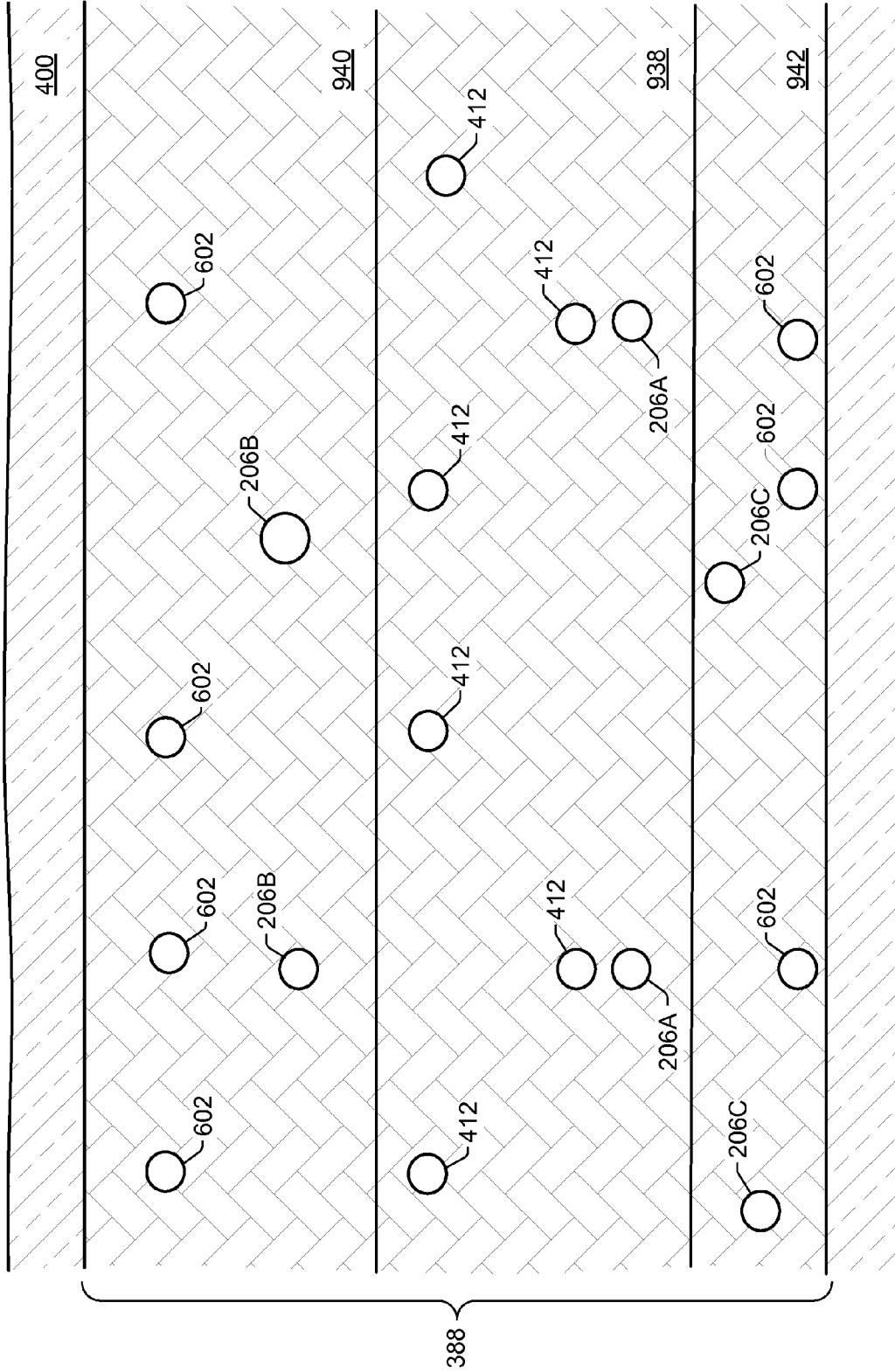

FIG. 181

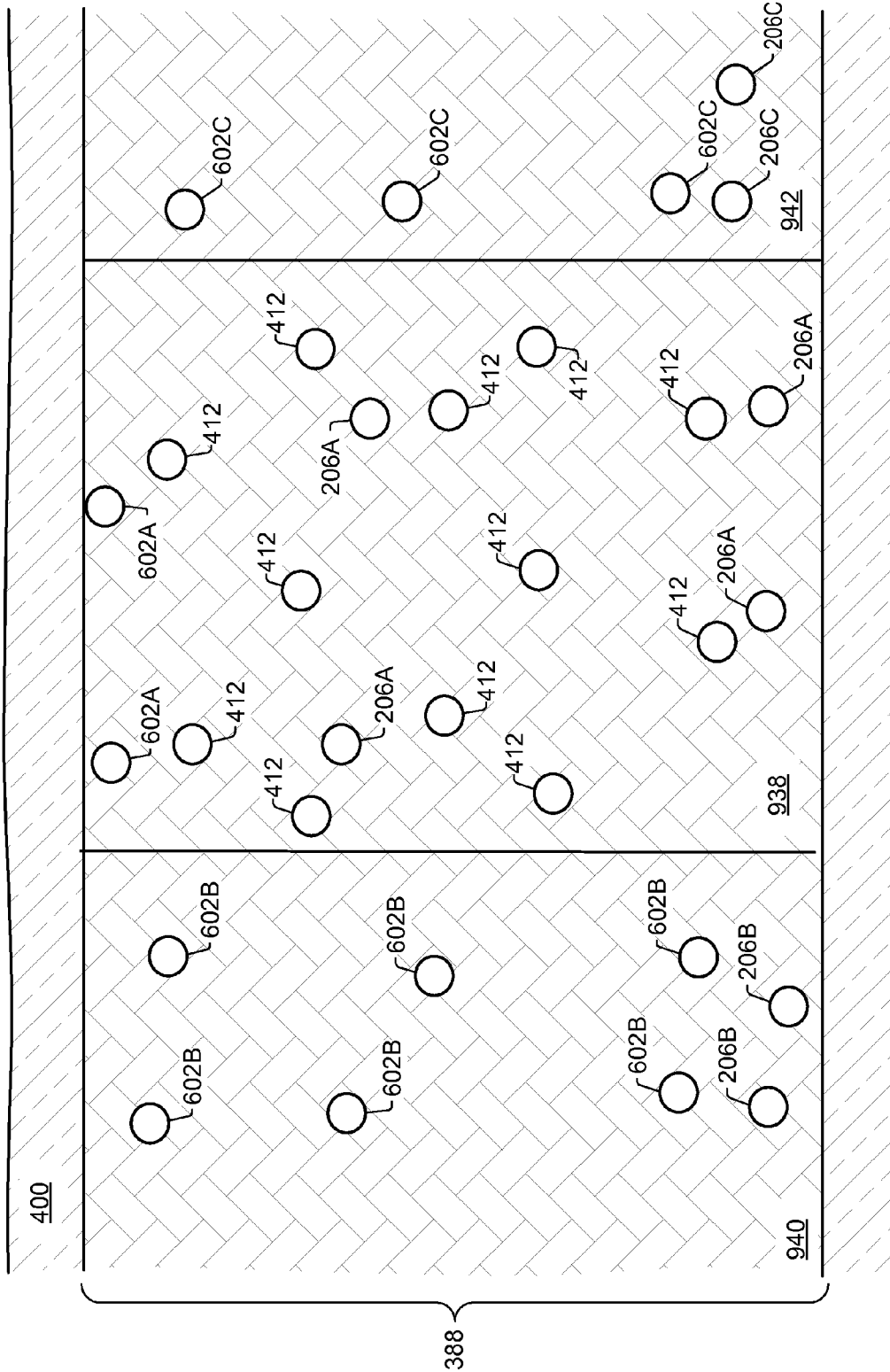

FIG. 182

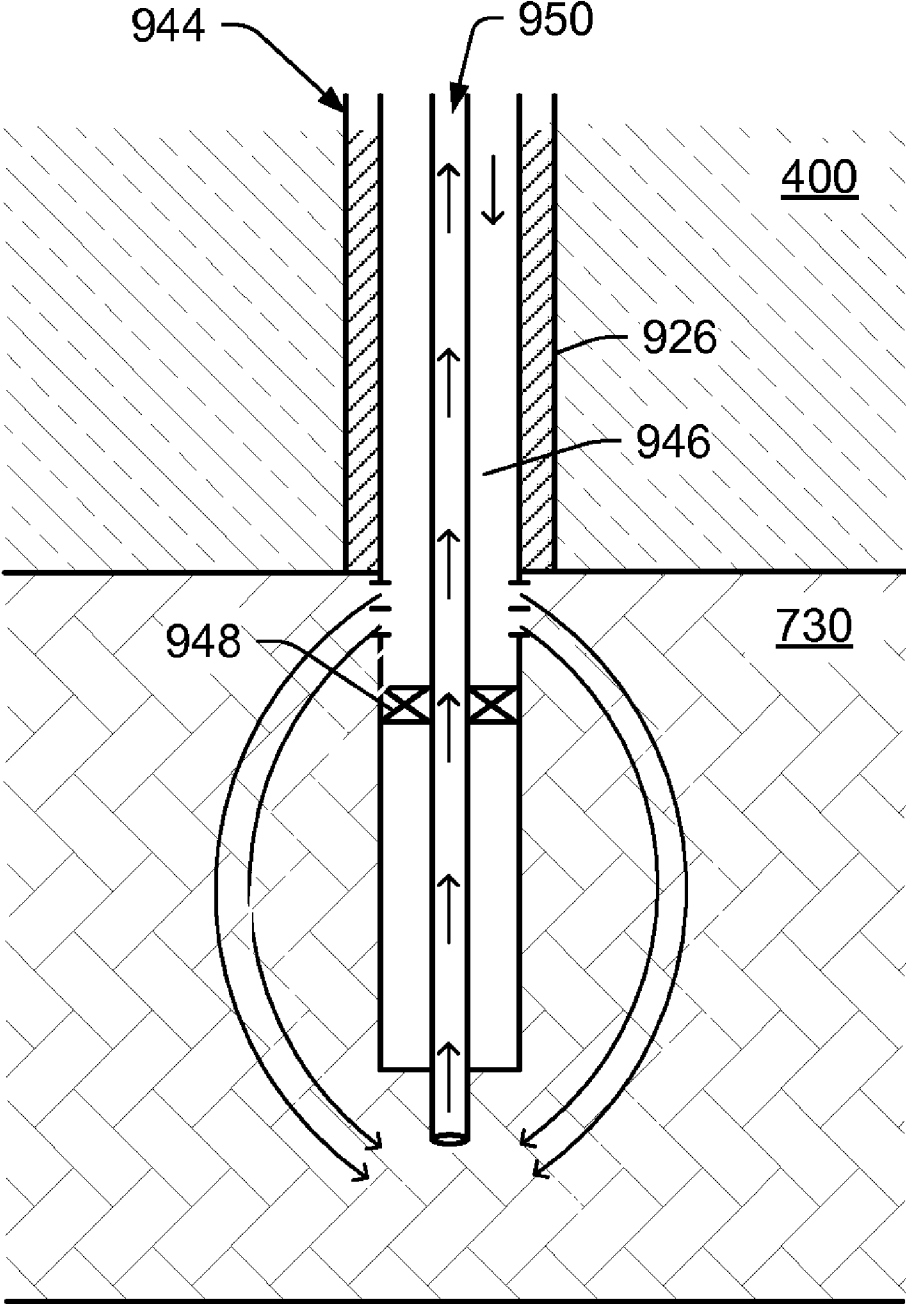

FIG. 183

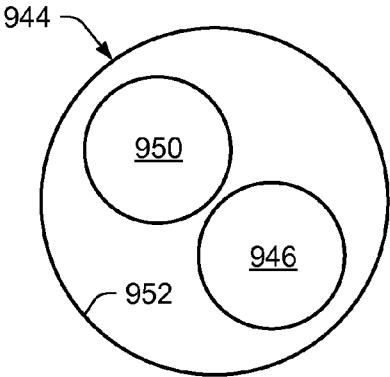

FIG. 184

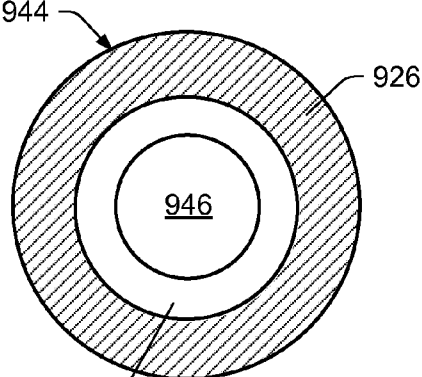

FIG. 185

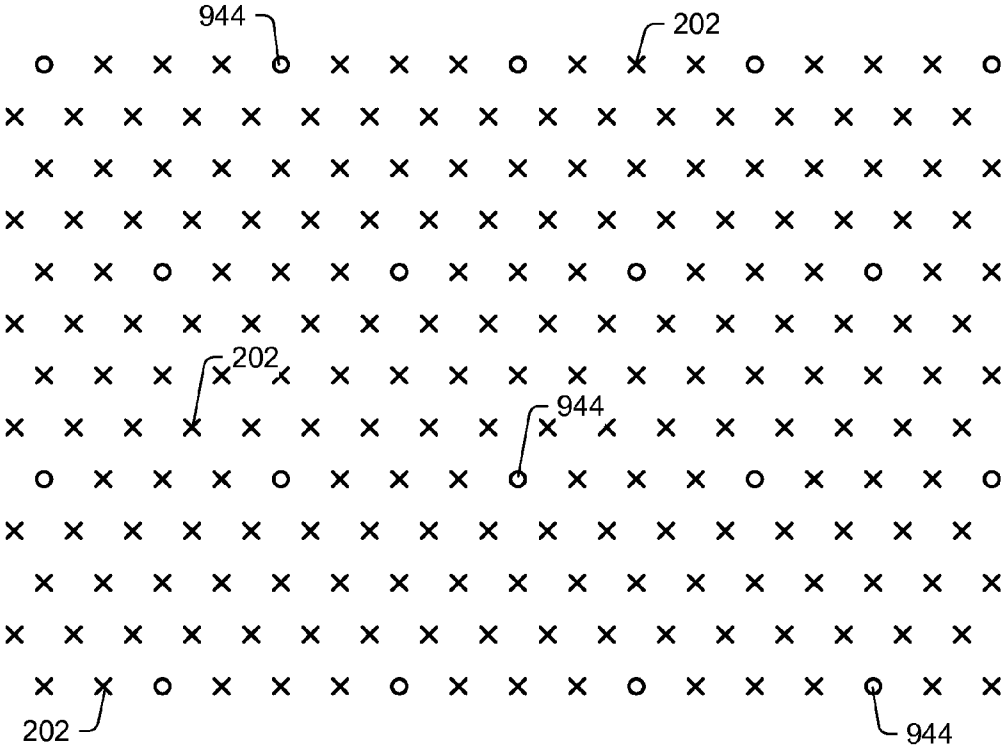

FIG. 186

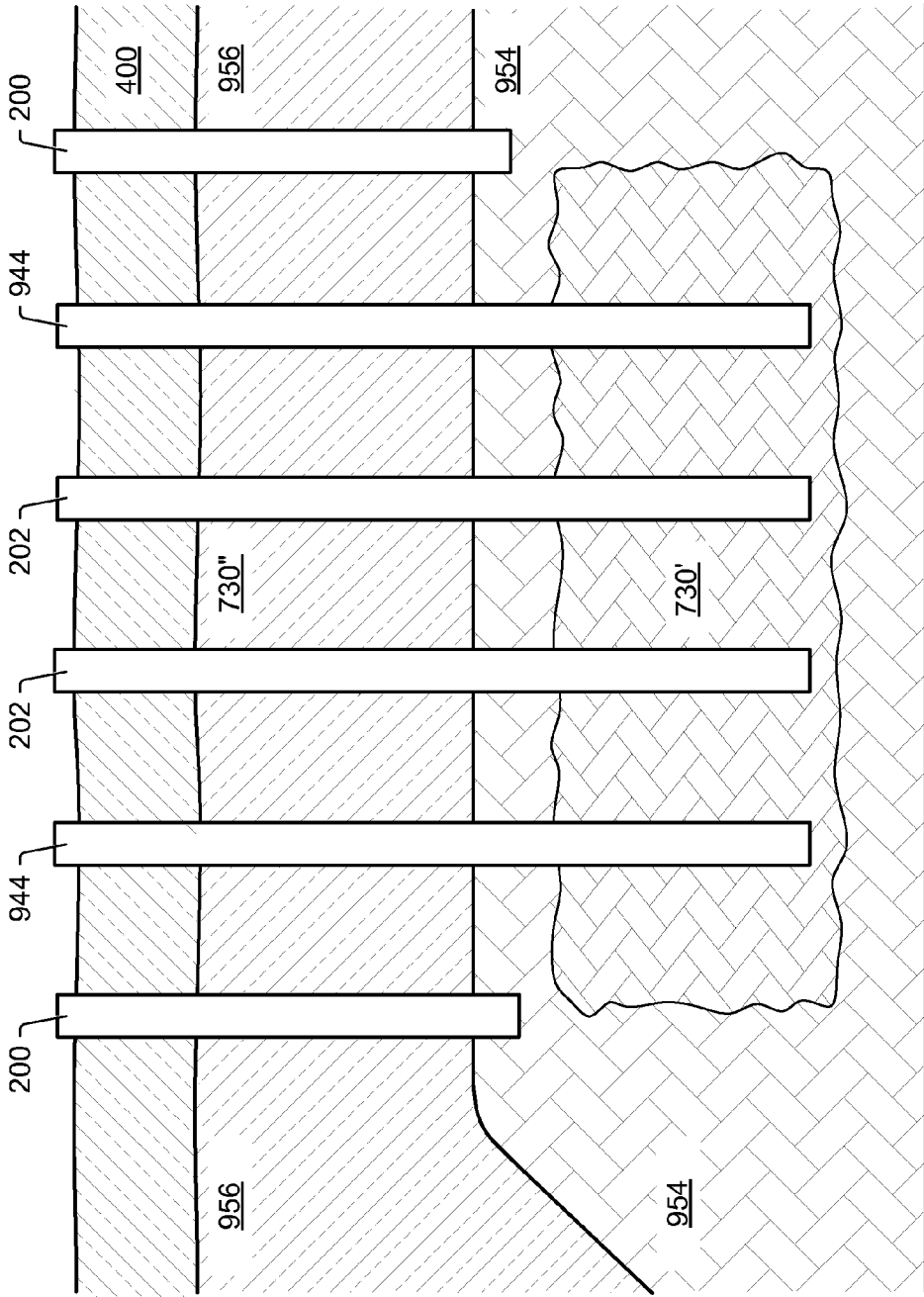

FIG. 187

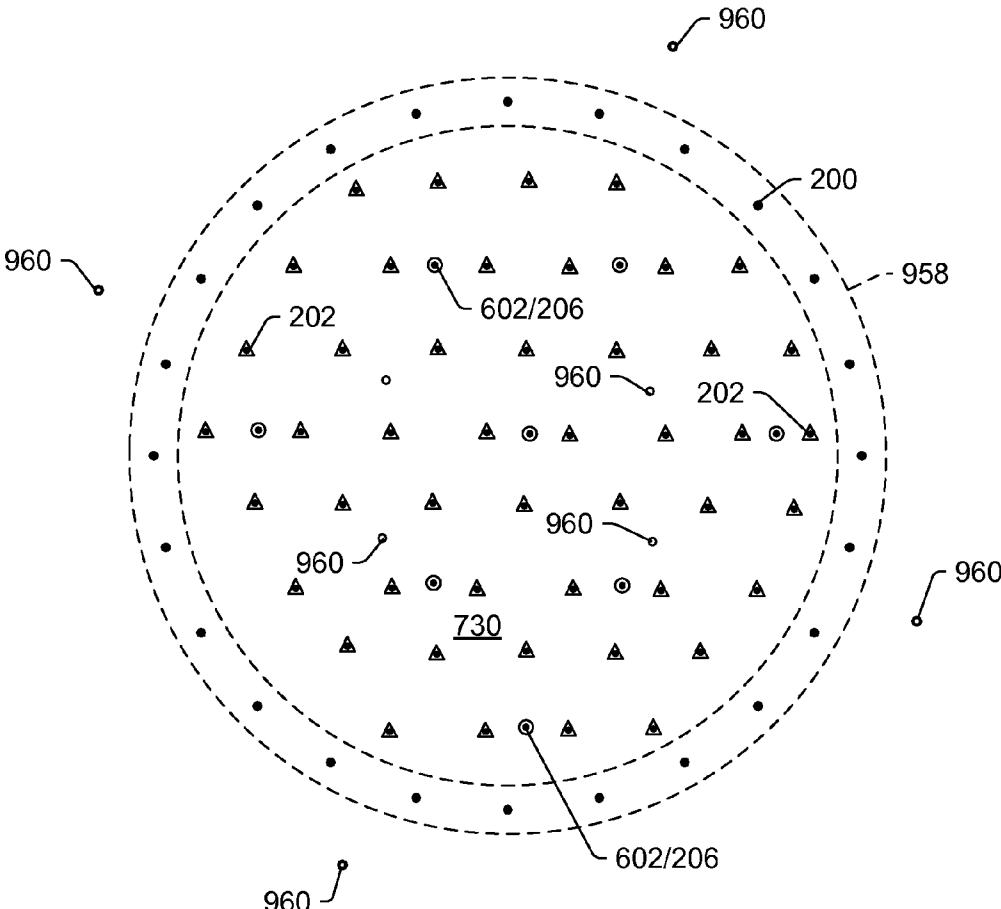

FIG. 188

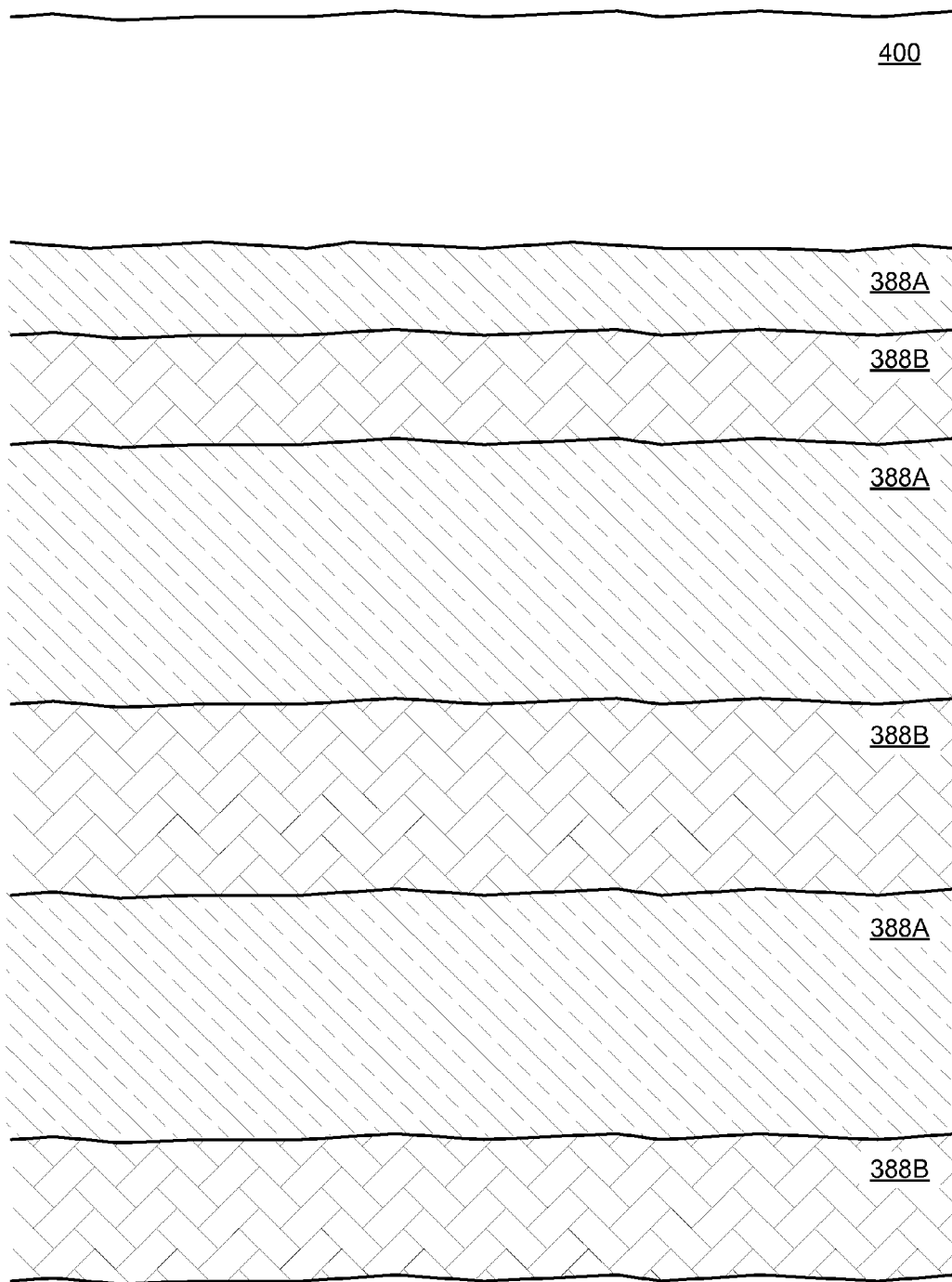

FIG. 189

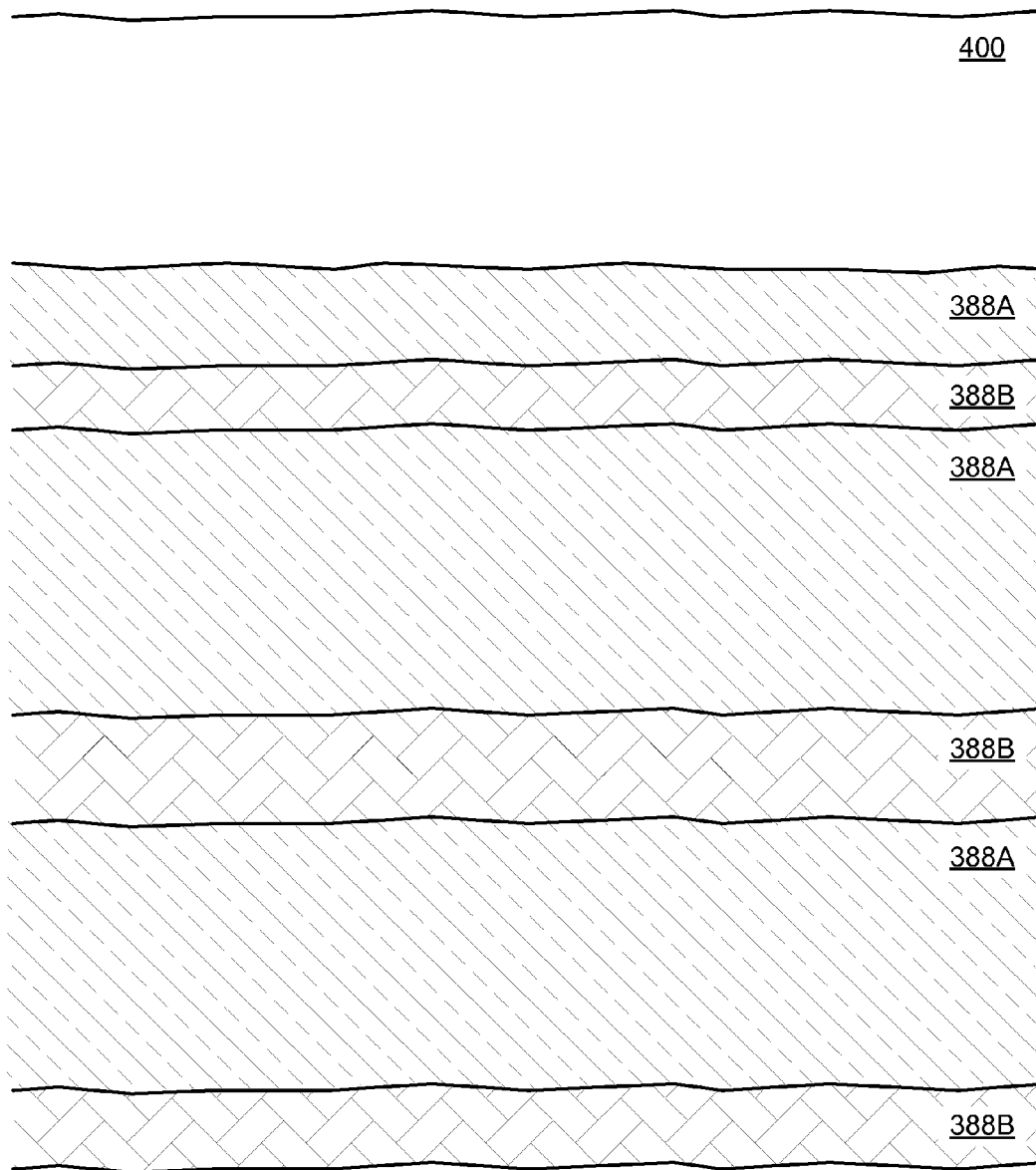

FIG. 190

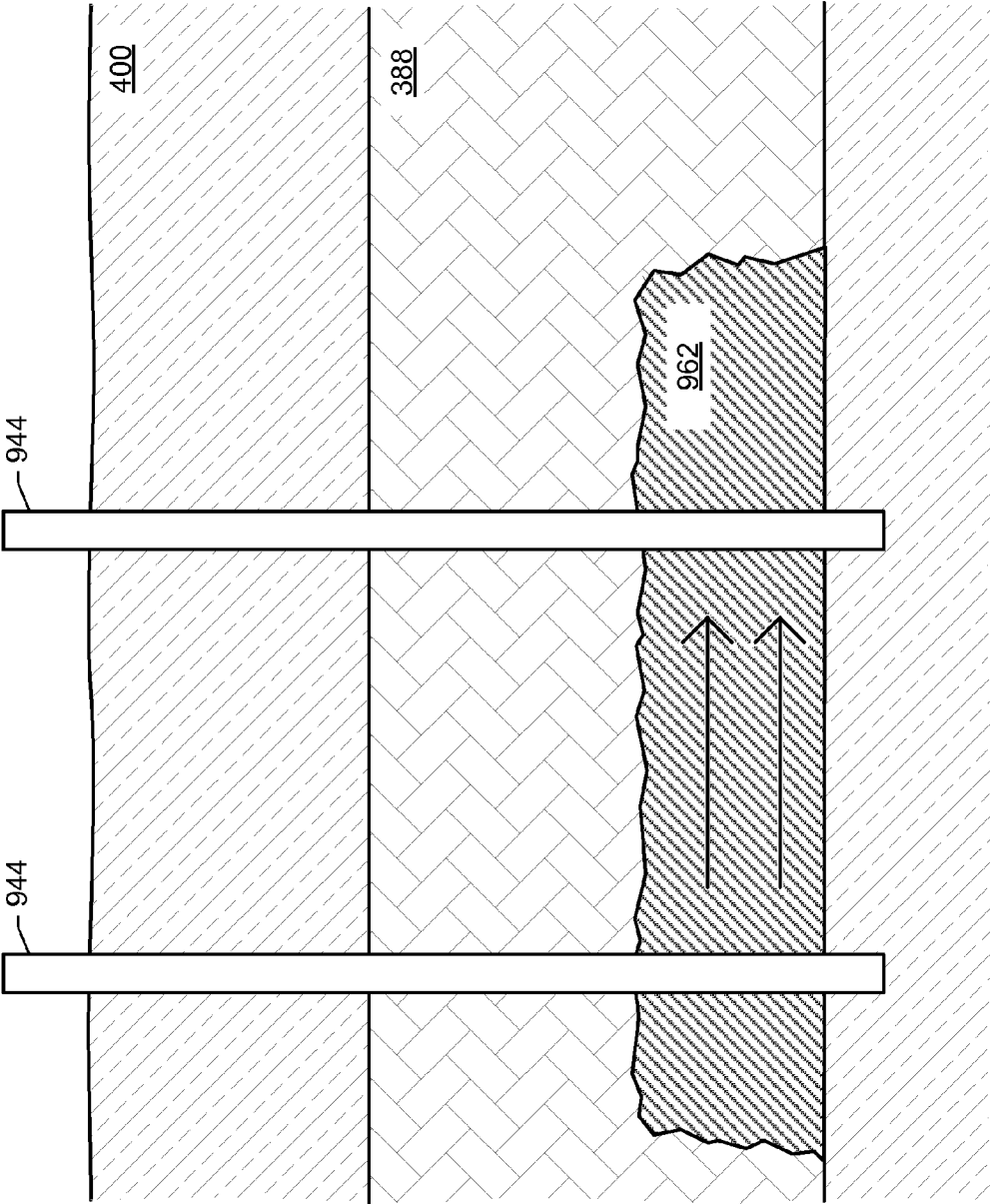

FIG. 191

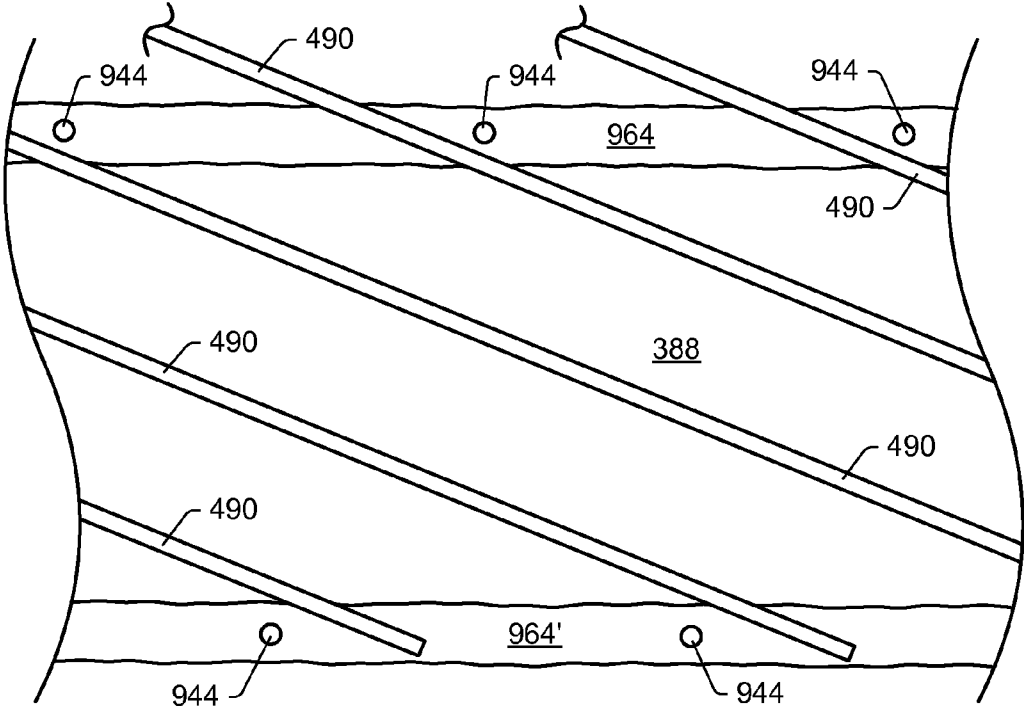

FIG. 192

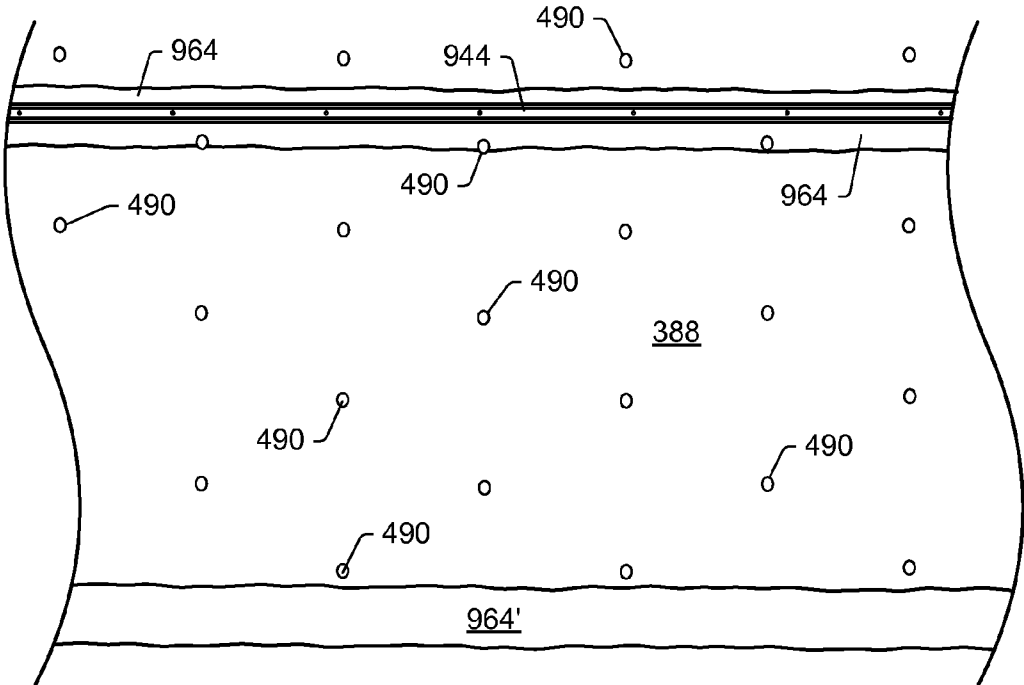

FIG. 193

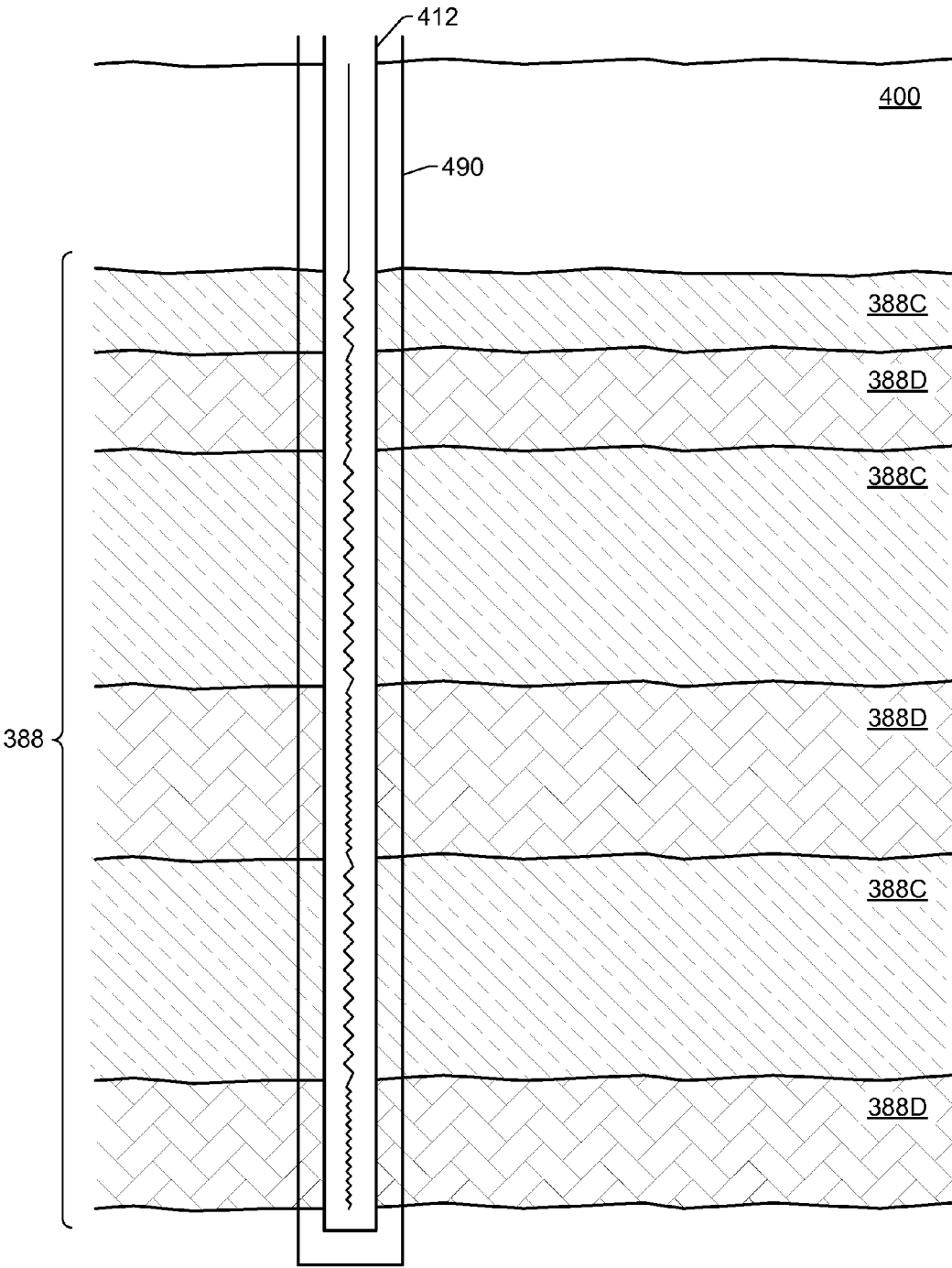

FIG. 194

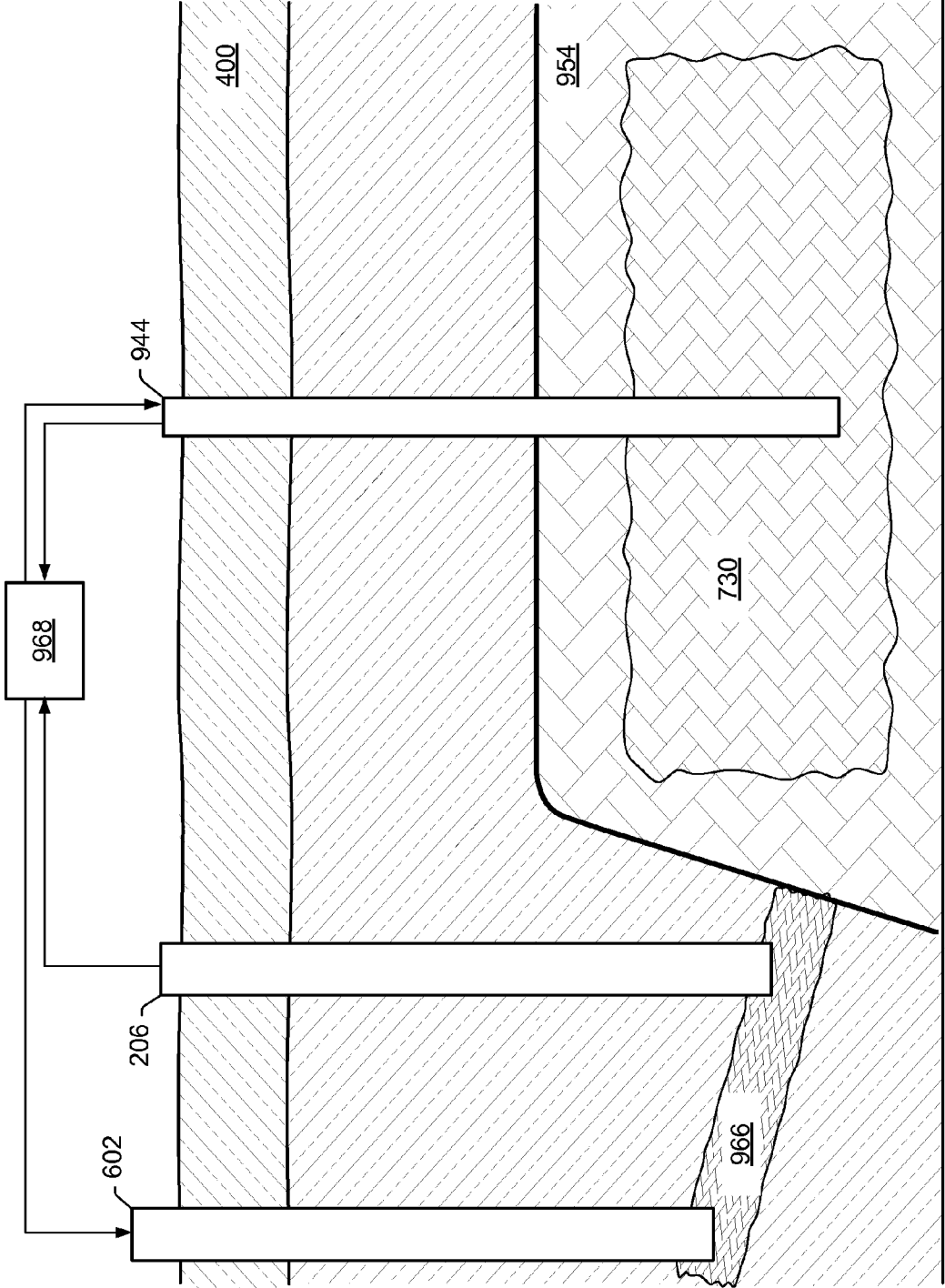

FIG. 195

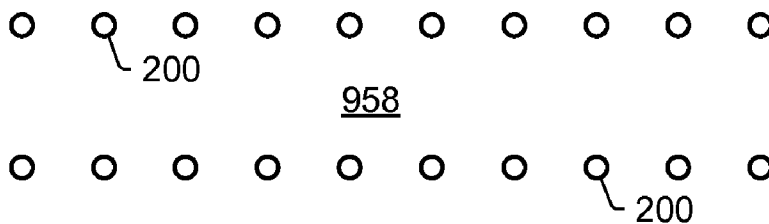
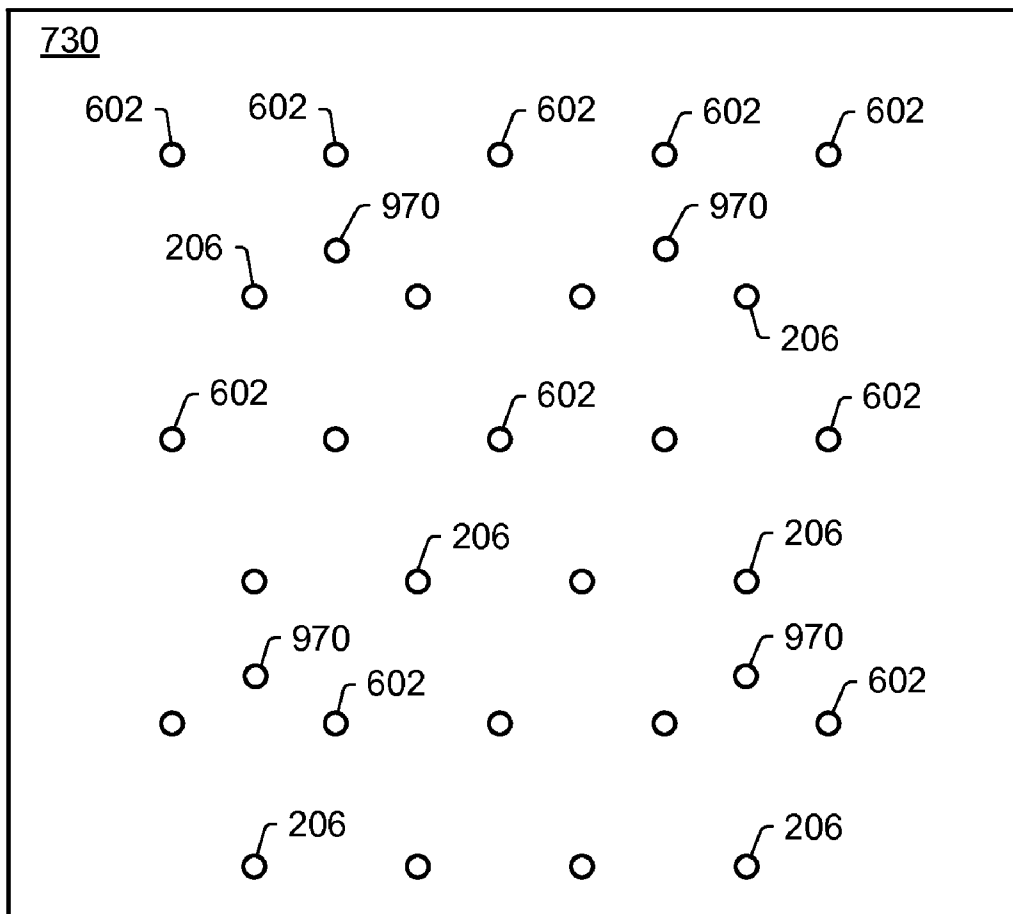

FIG. 196

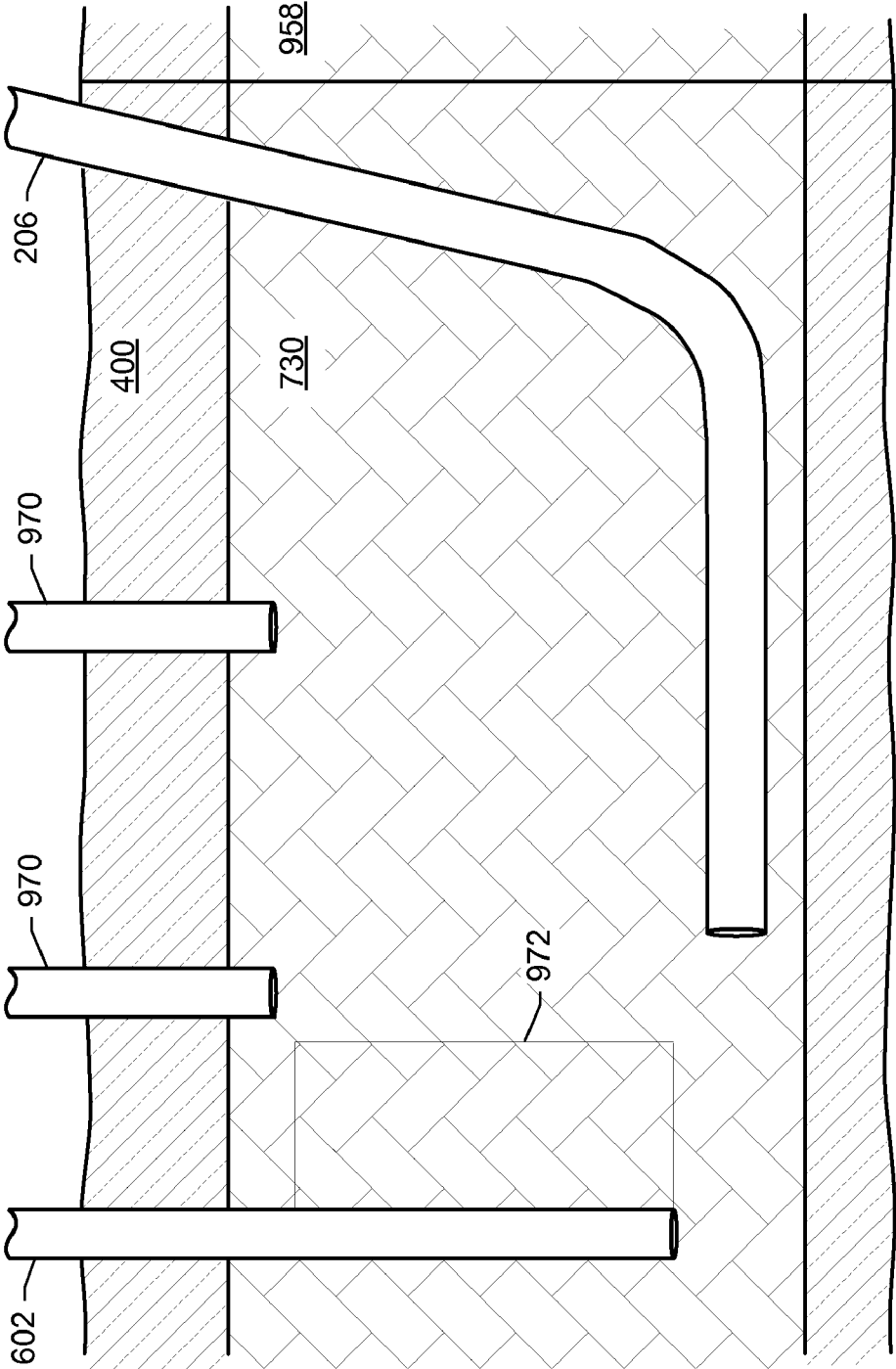

FIG. 197

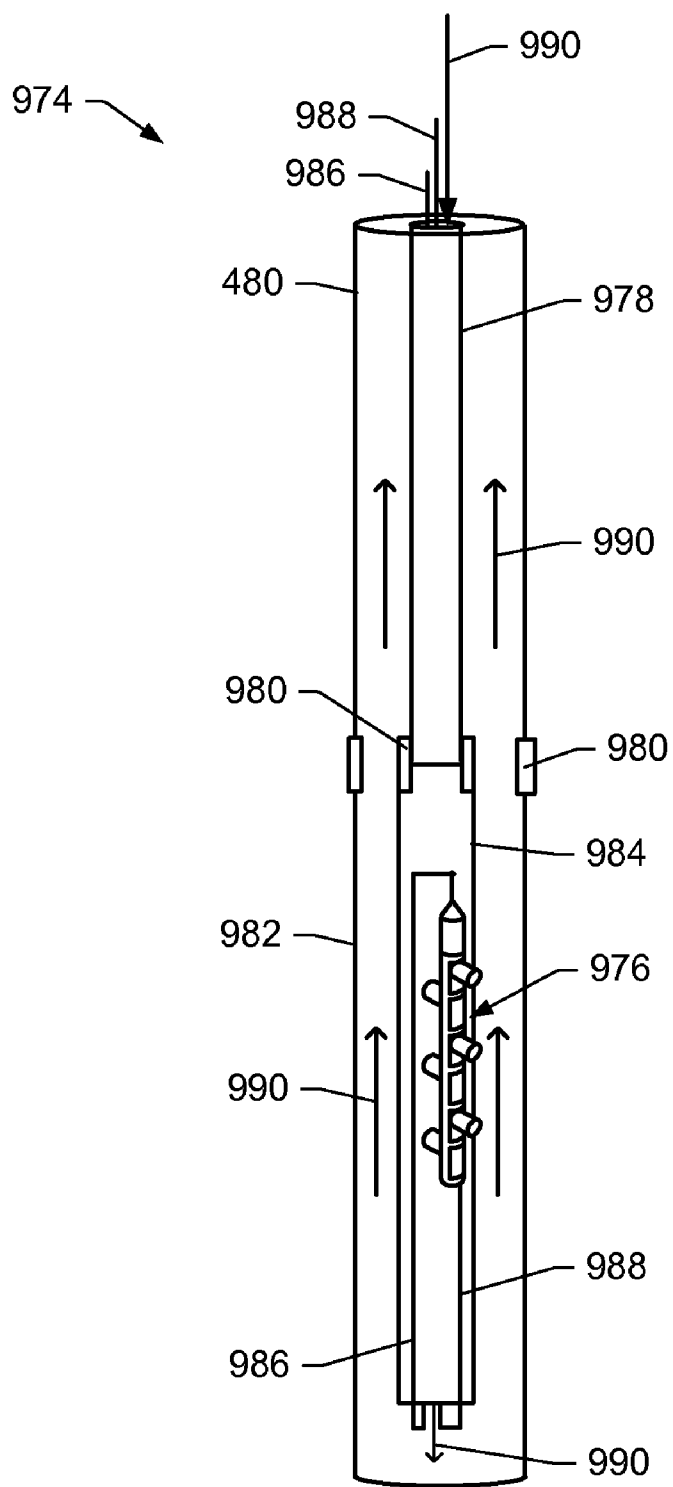

FIG. 198

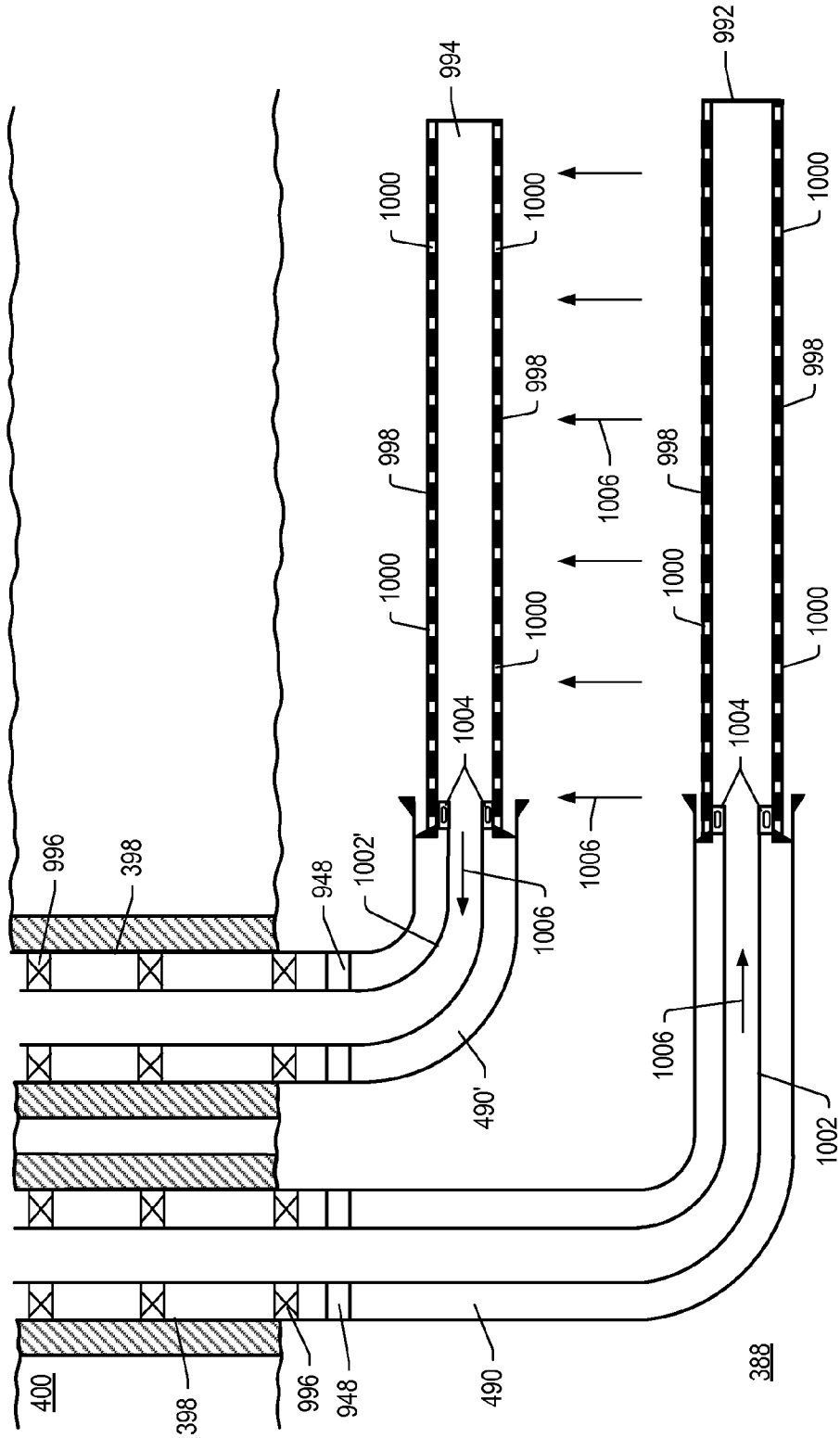

FIG. 199

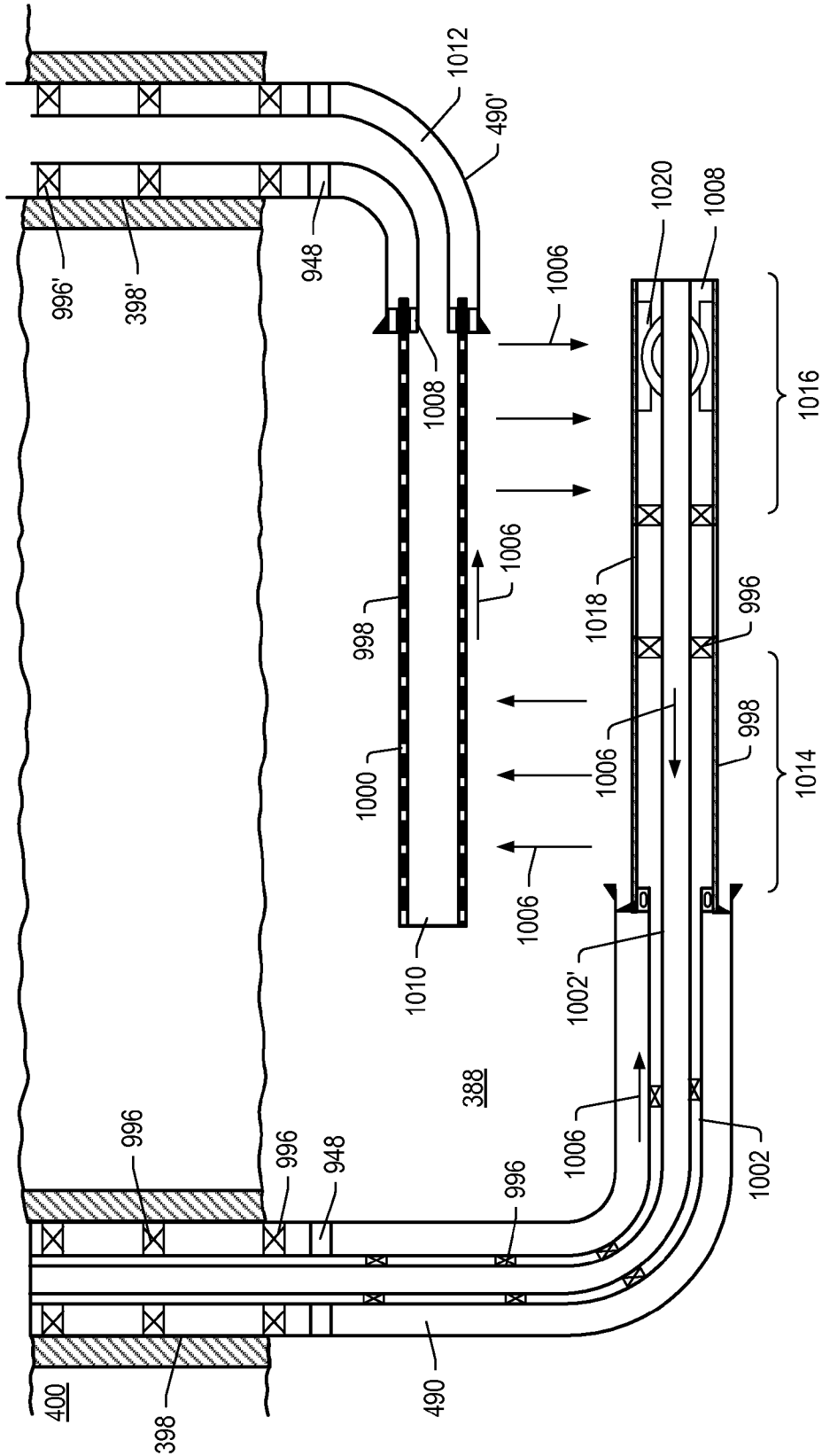

FIG. 200

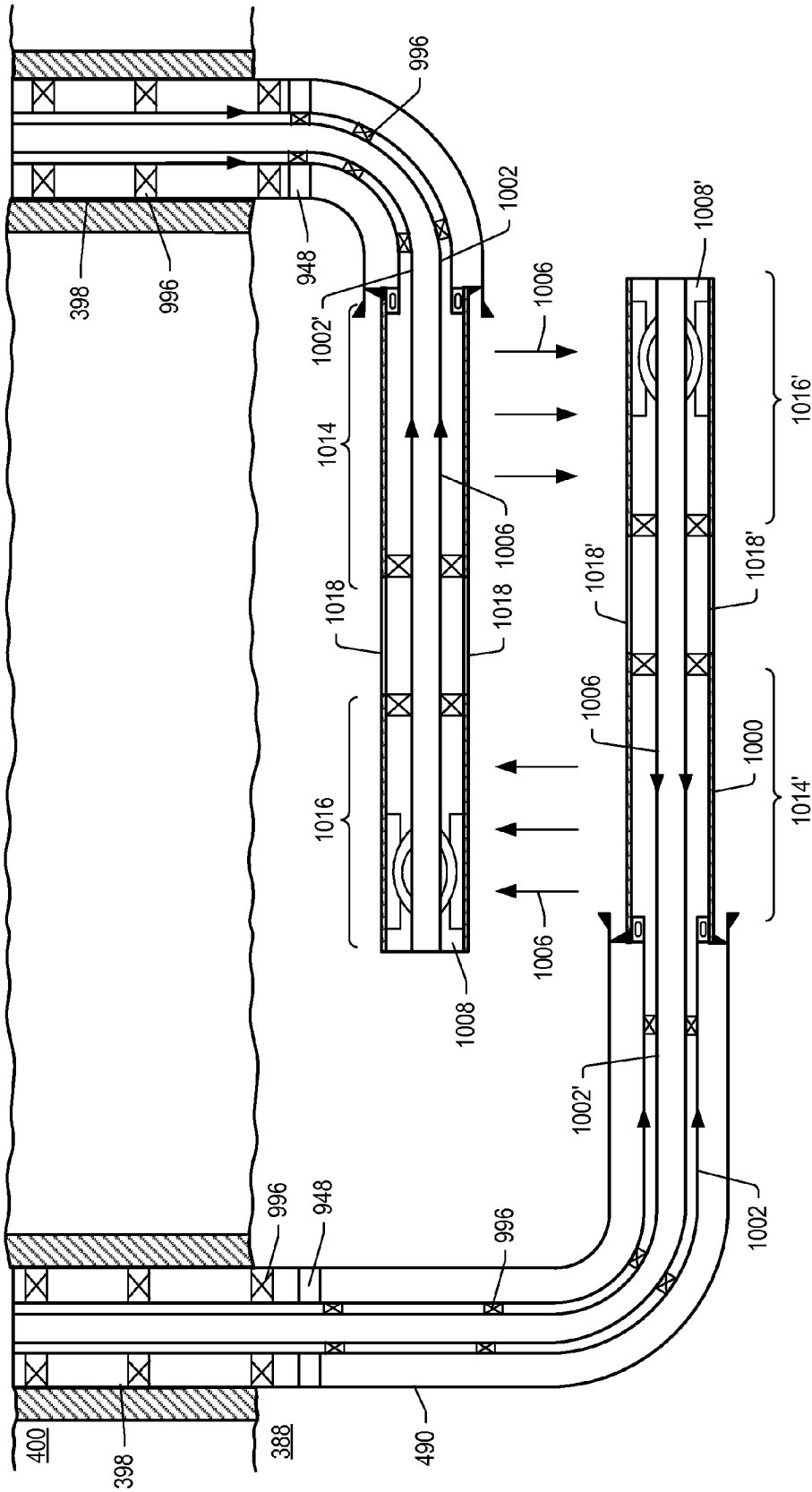

FIG. 201

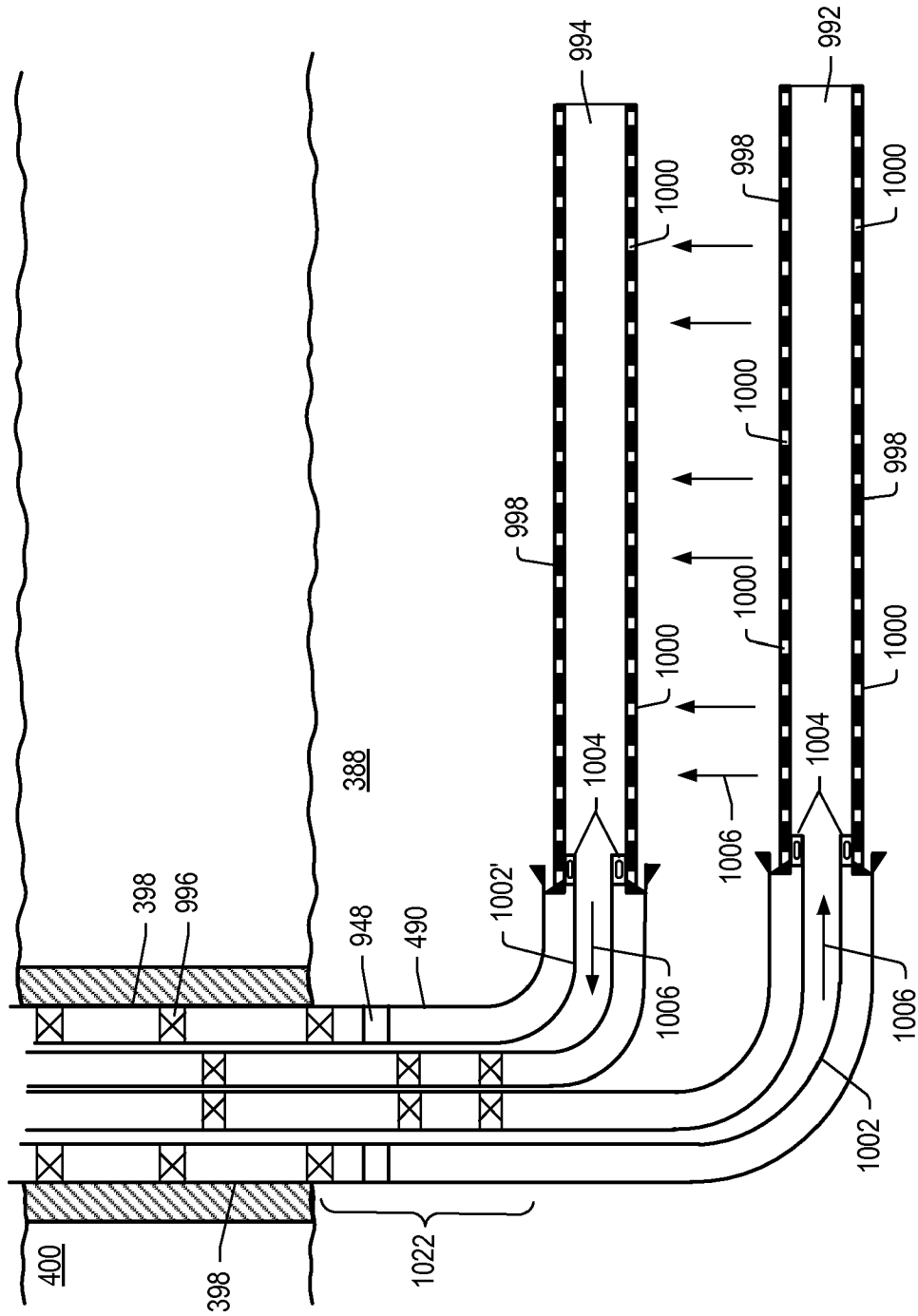

FIG. 202

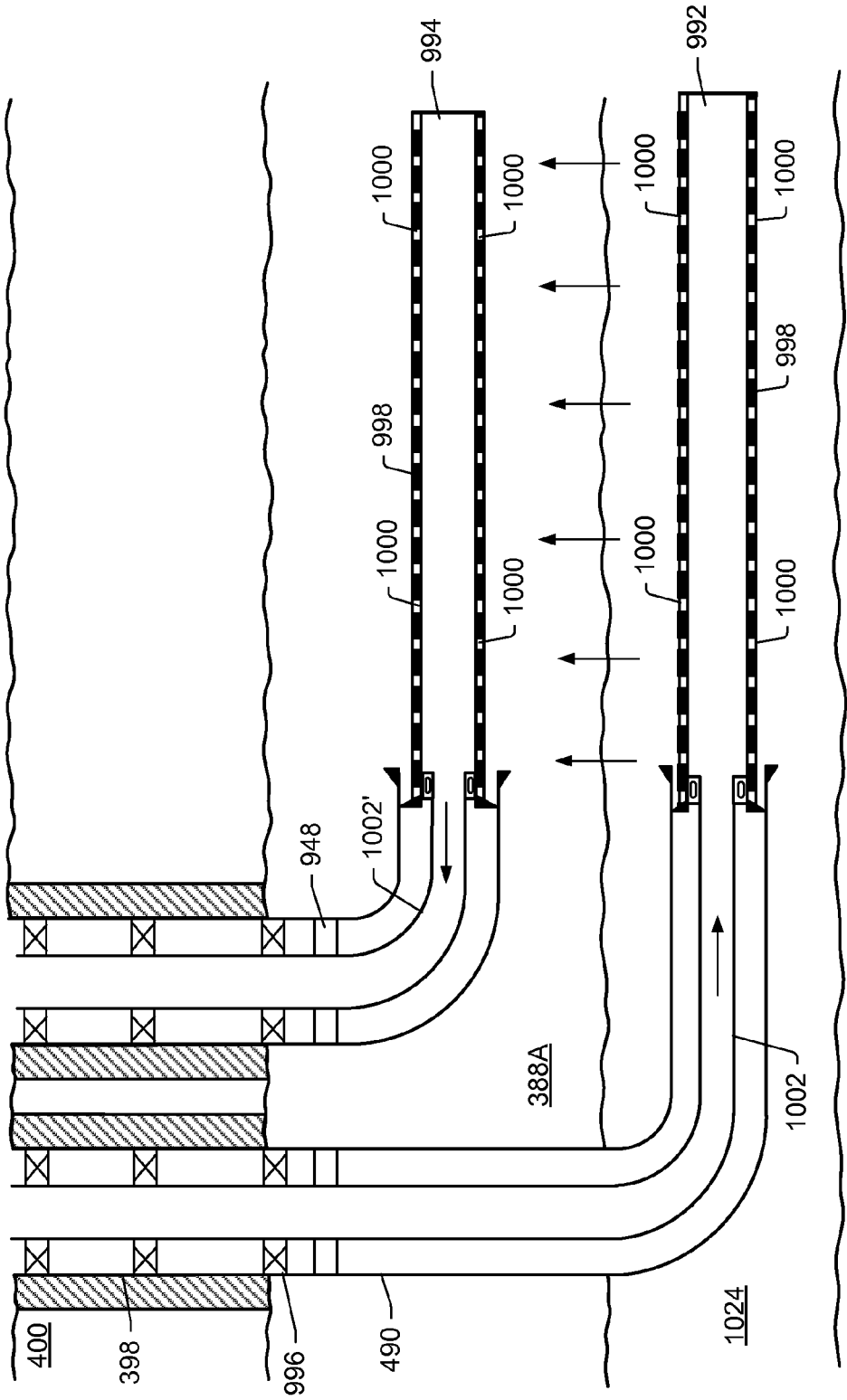

FIG. 203

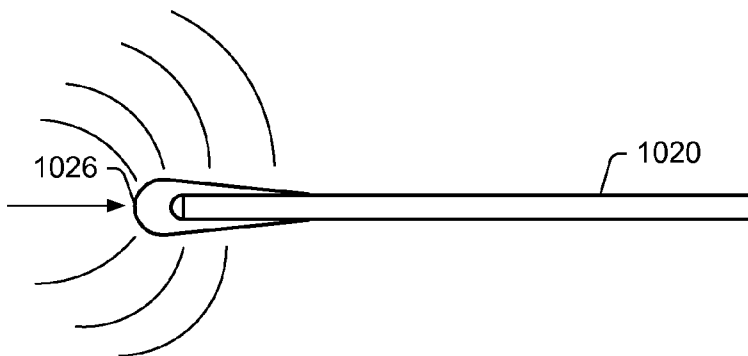

FIG. 204A

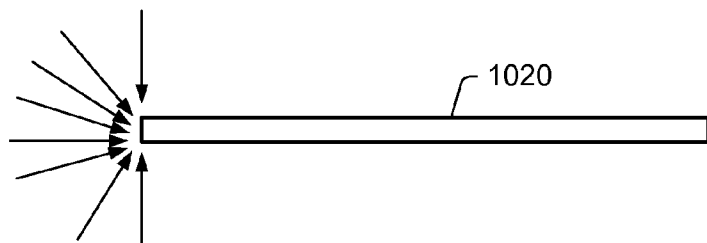

FIG. 204B

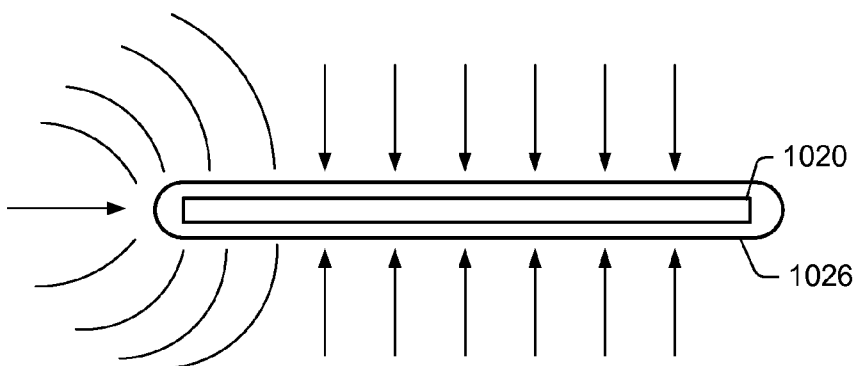

FIG. 205A

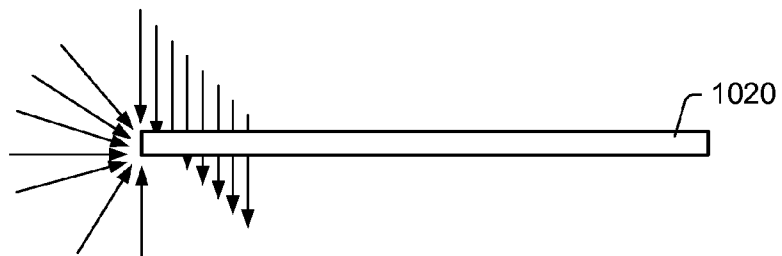

FIG. 205B

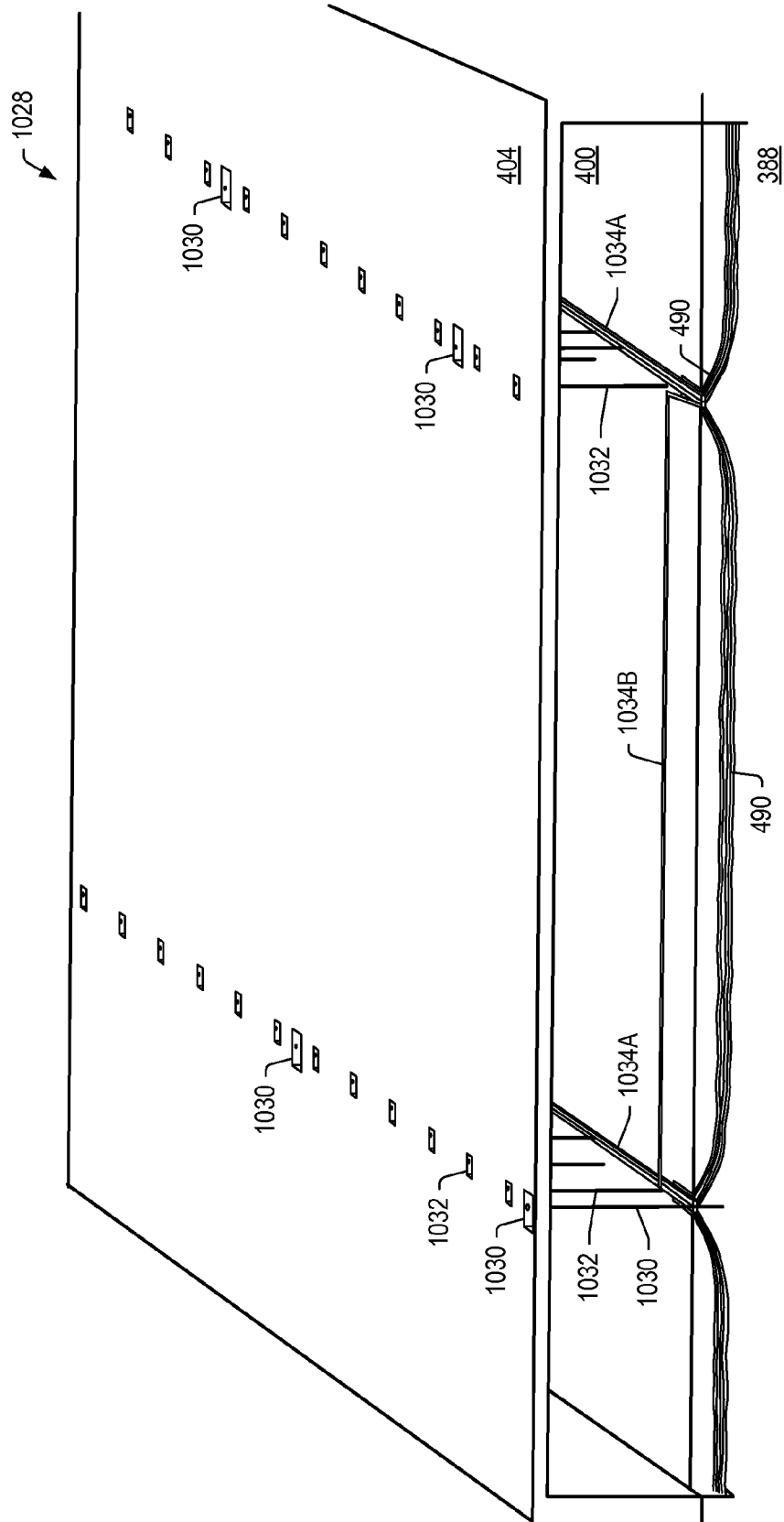

FIG. 206

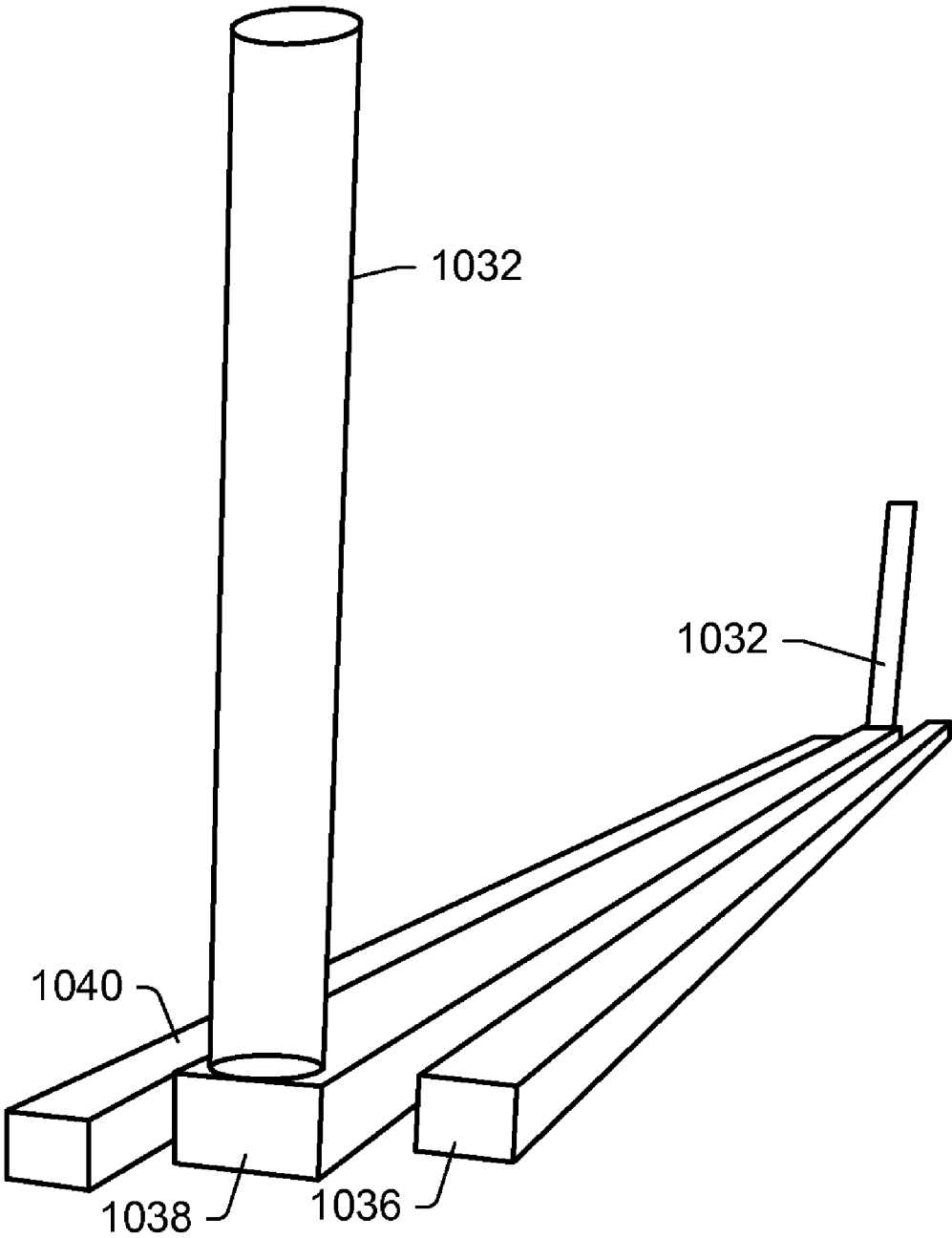

FIG. 208

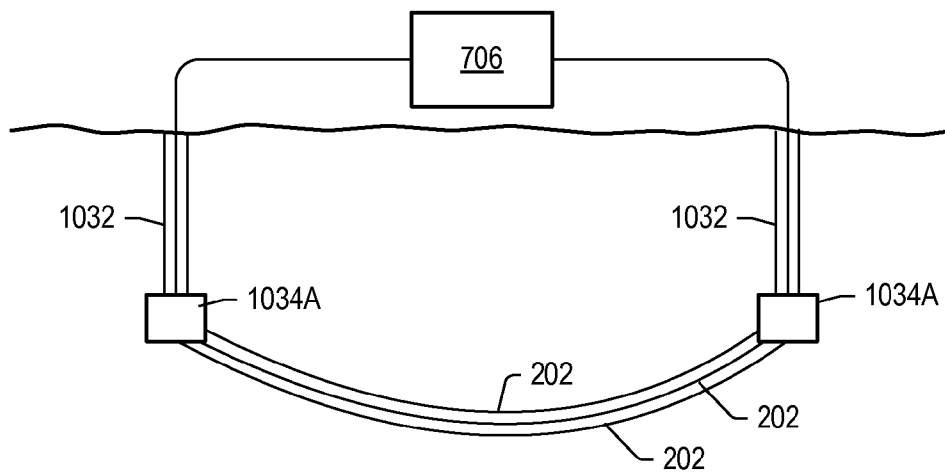

FIG. 209

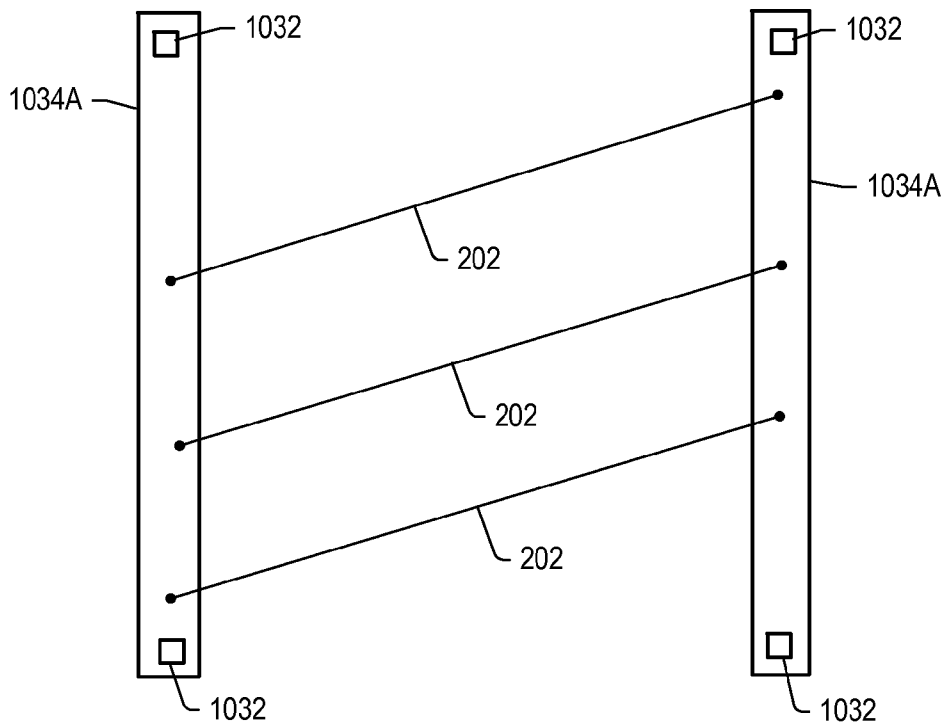

FIG. 210

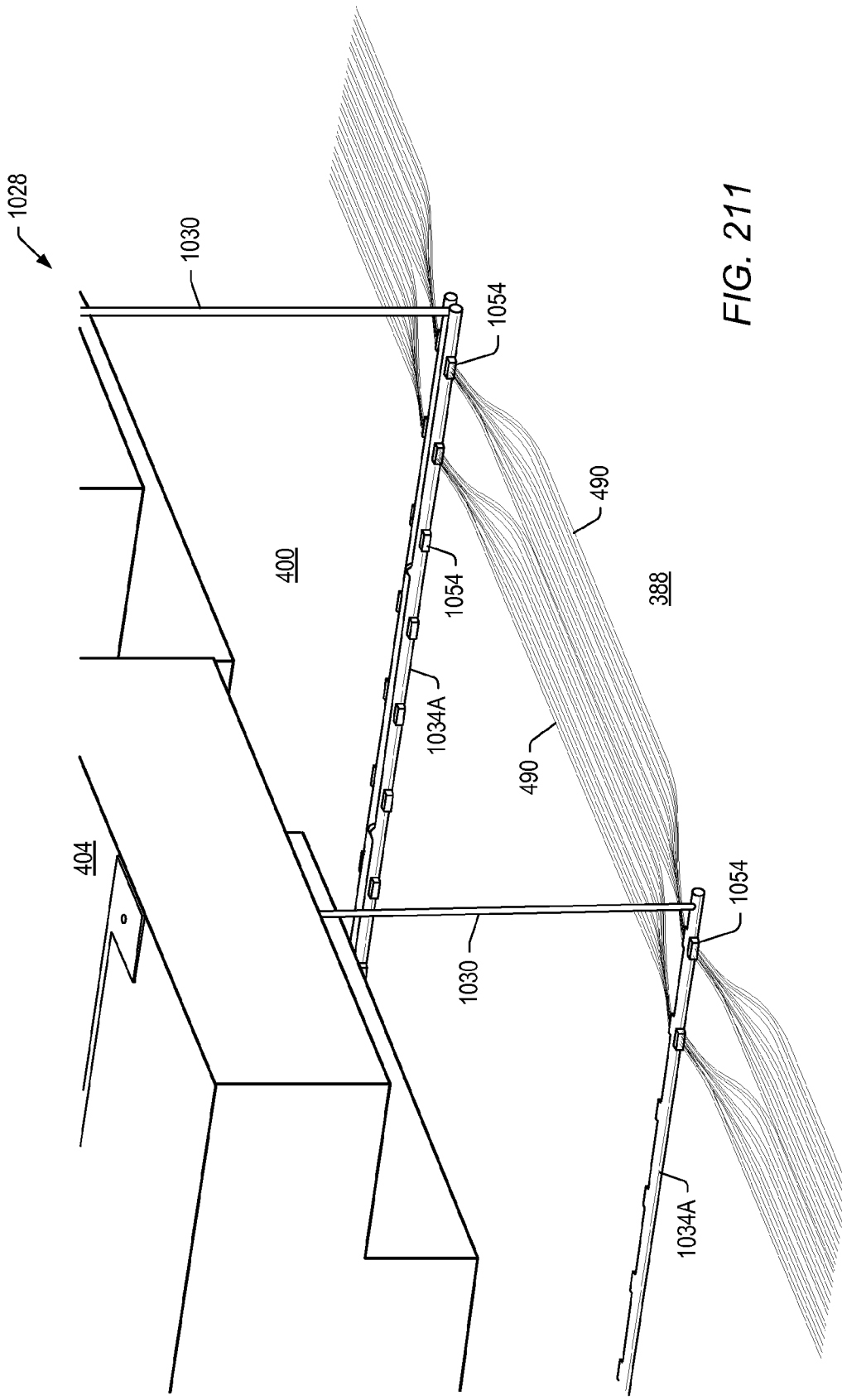

FIG. 211

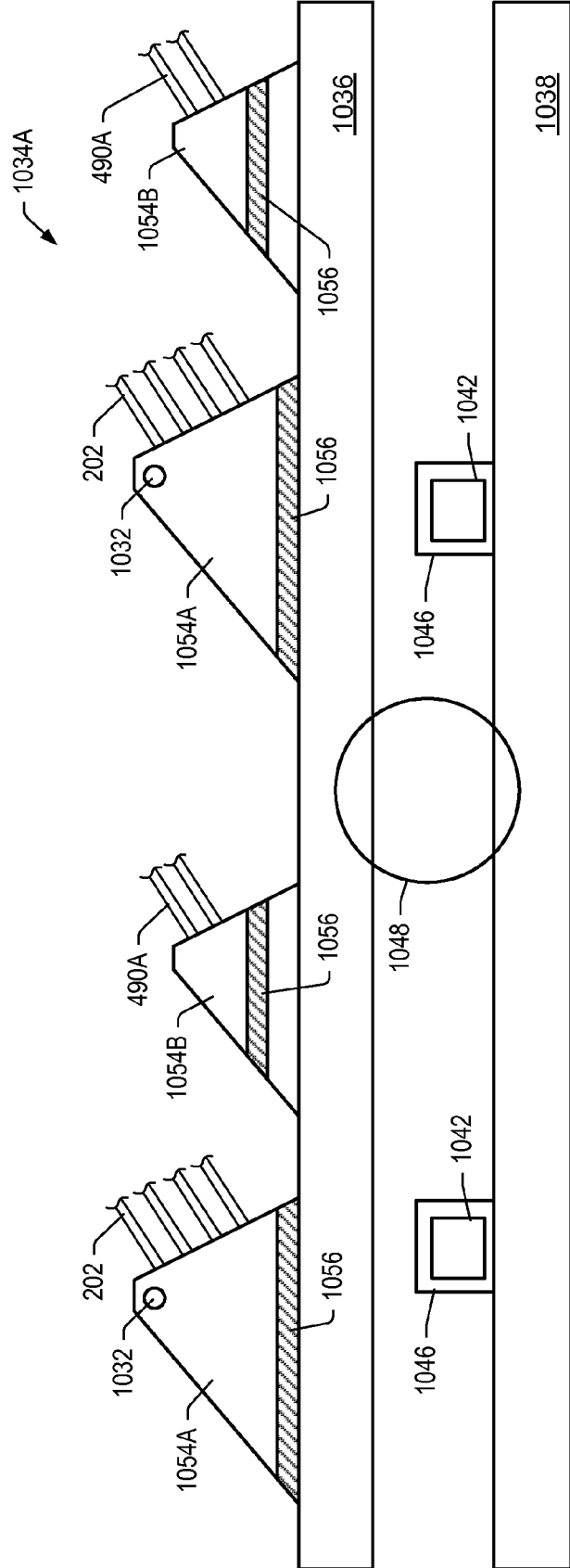

FIG. 212

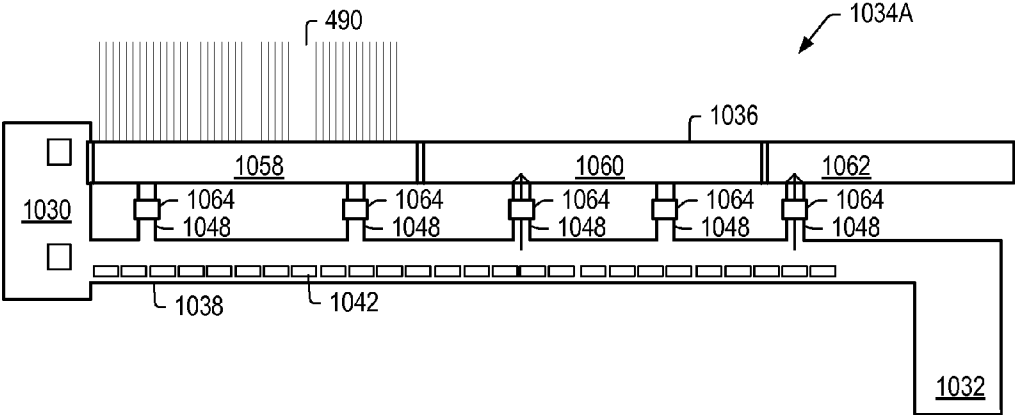

FIG. 213

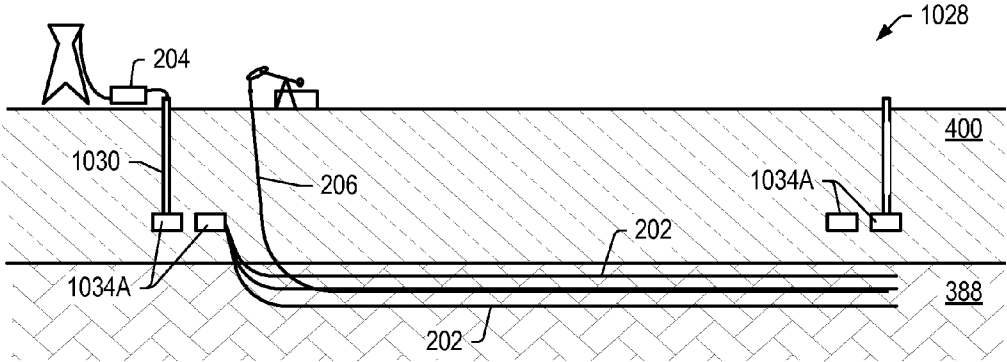

FIG. 214

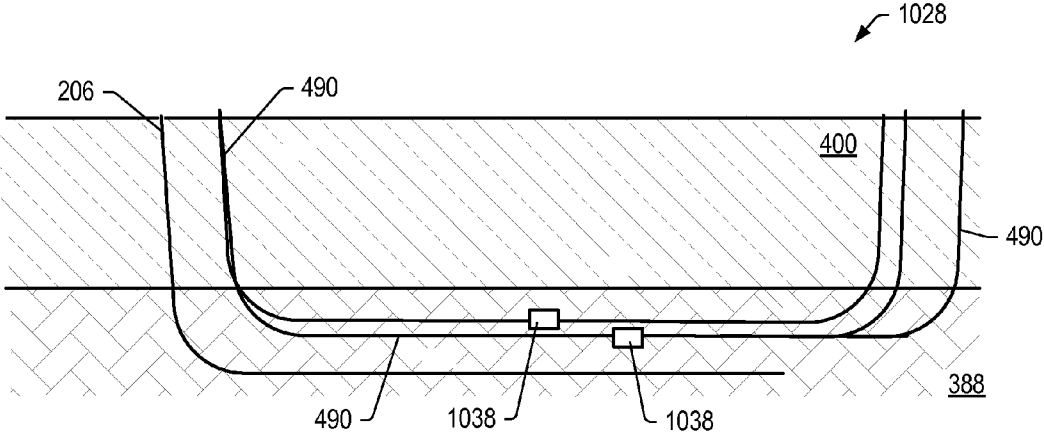
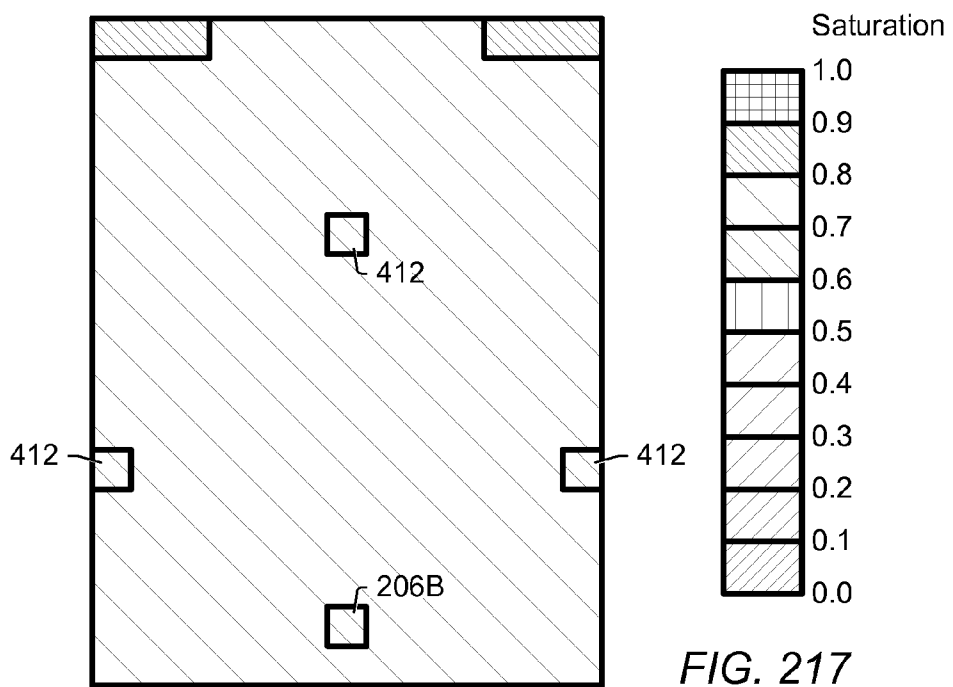
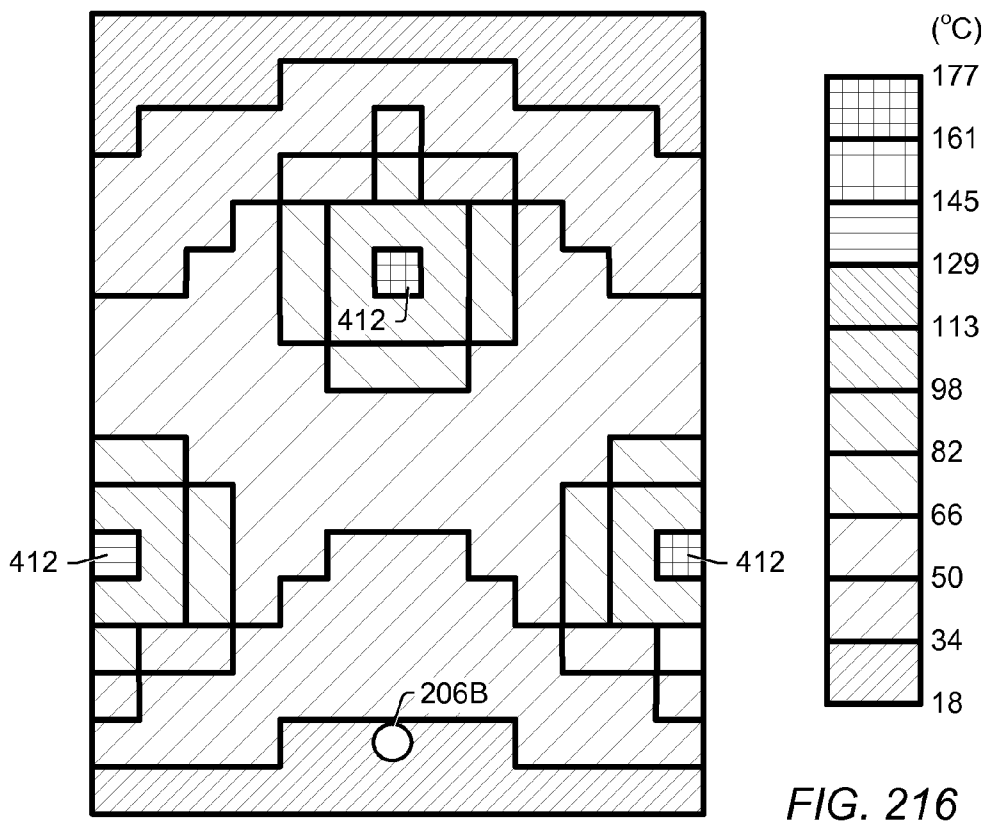
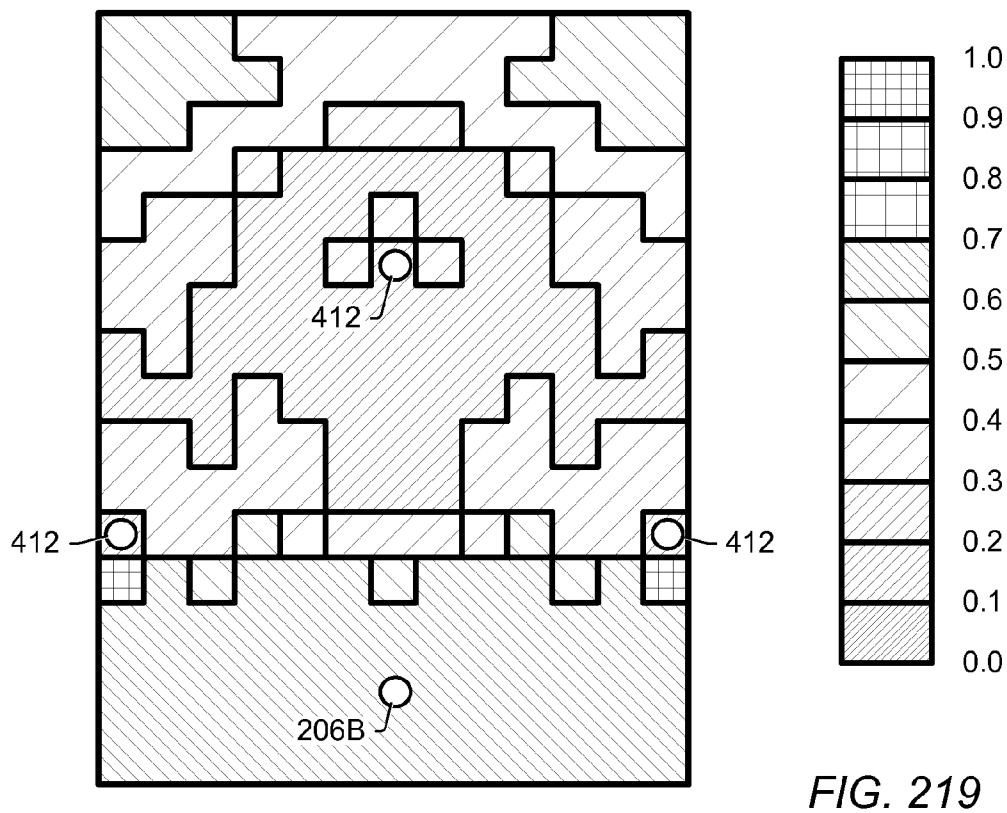
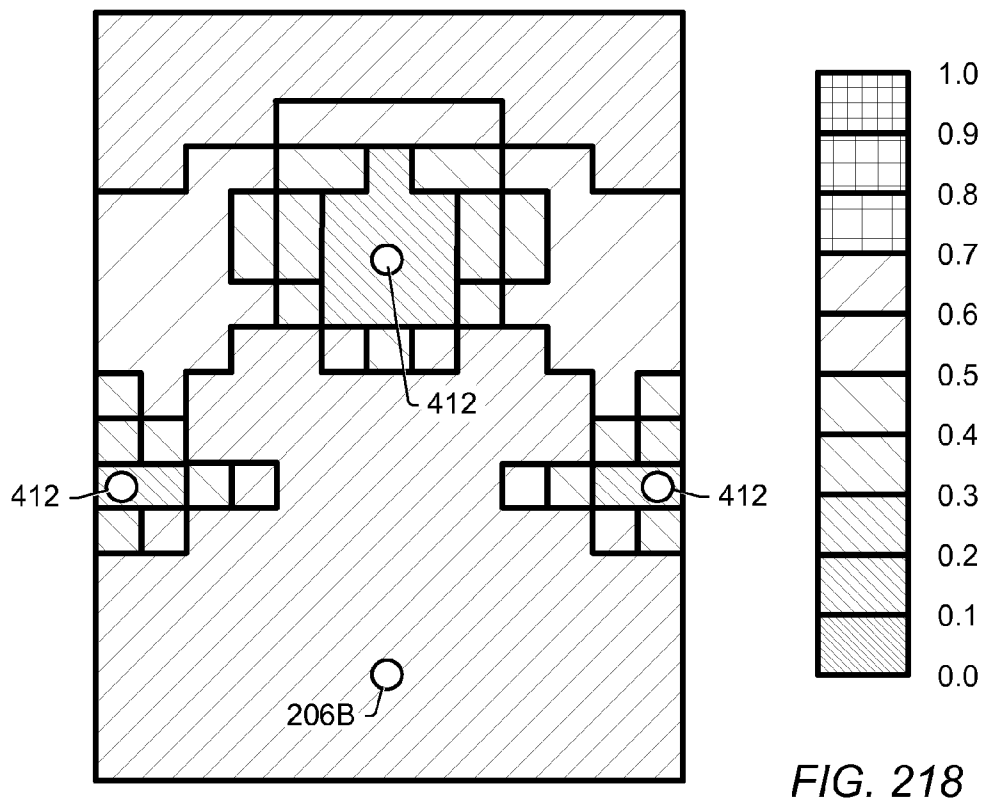

FIG. 215





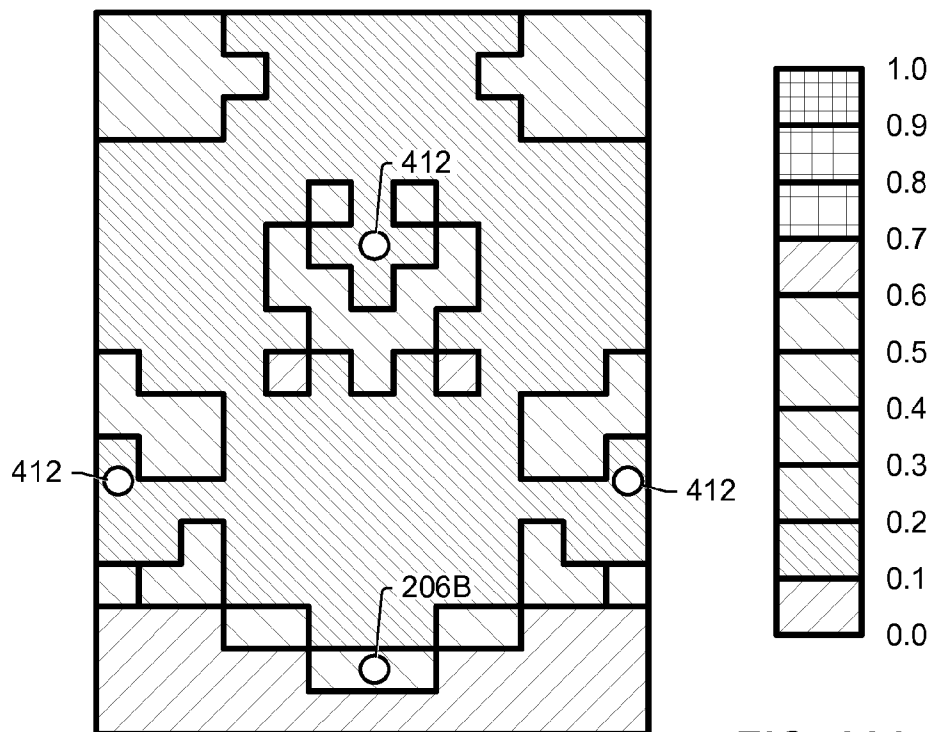

FIG. 220

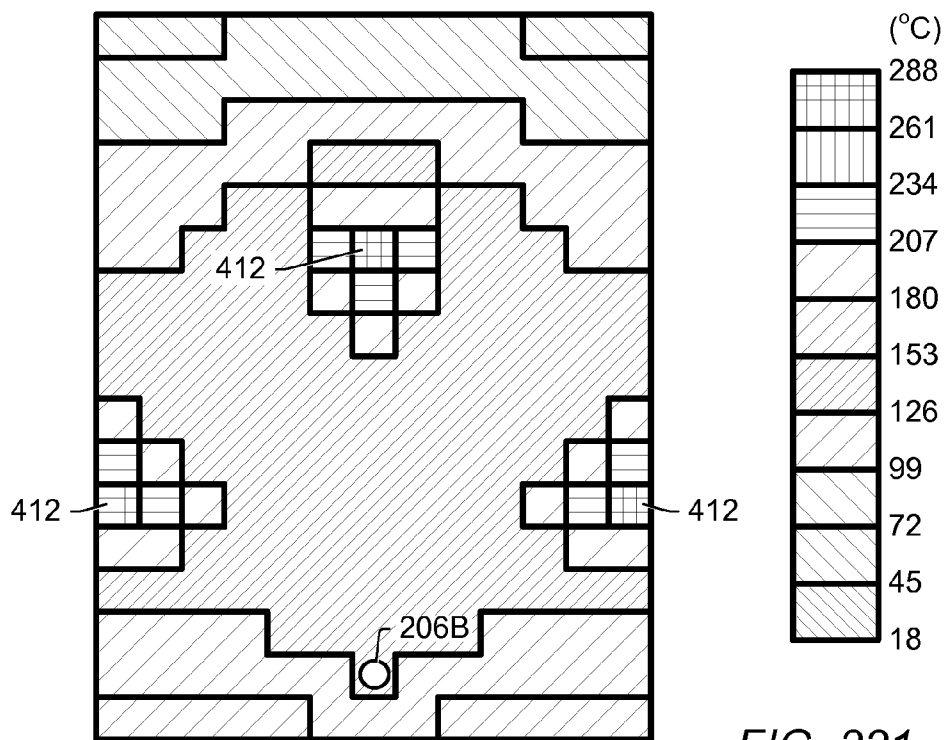

FIG. 221

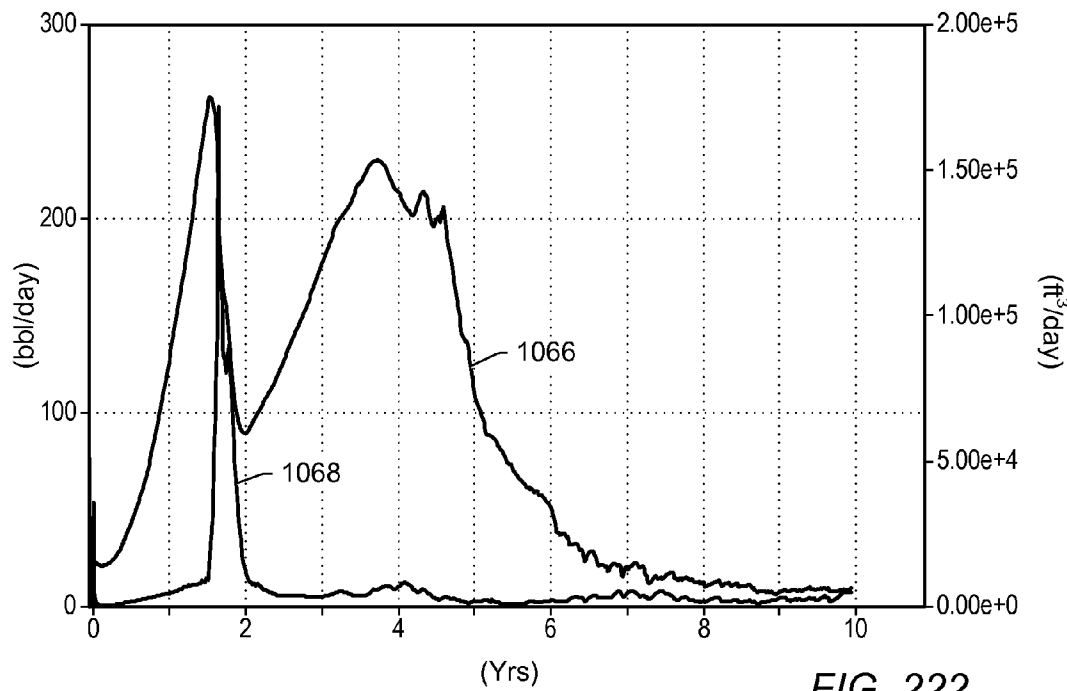

FIG. 222

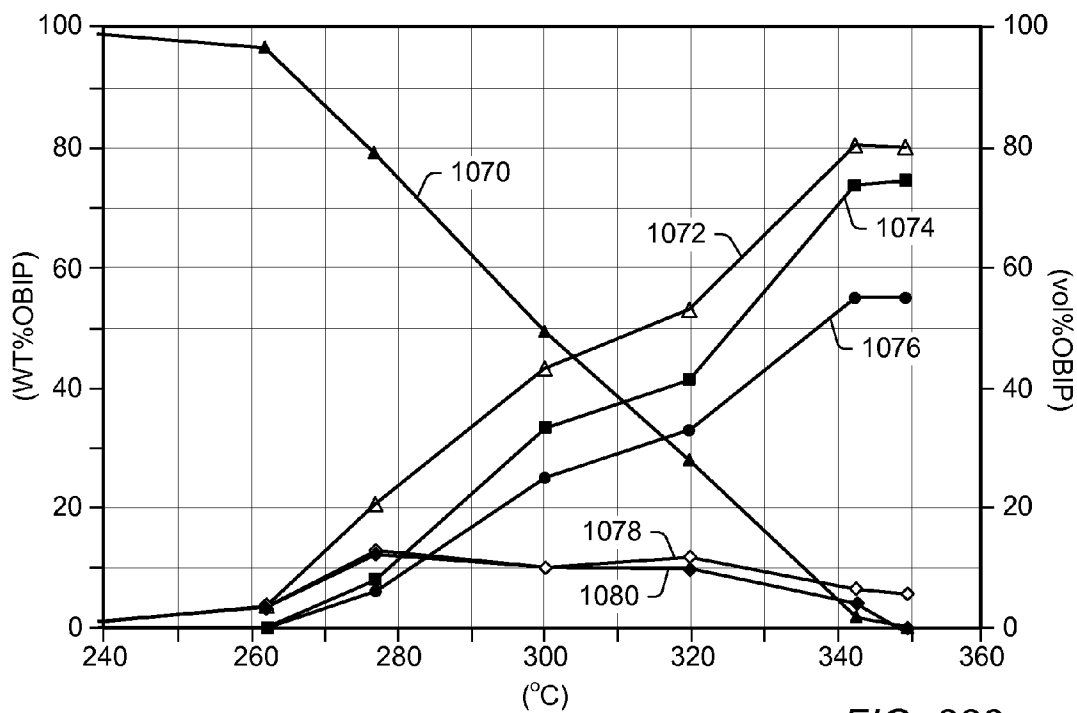

FIG. 223

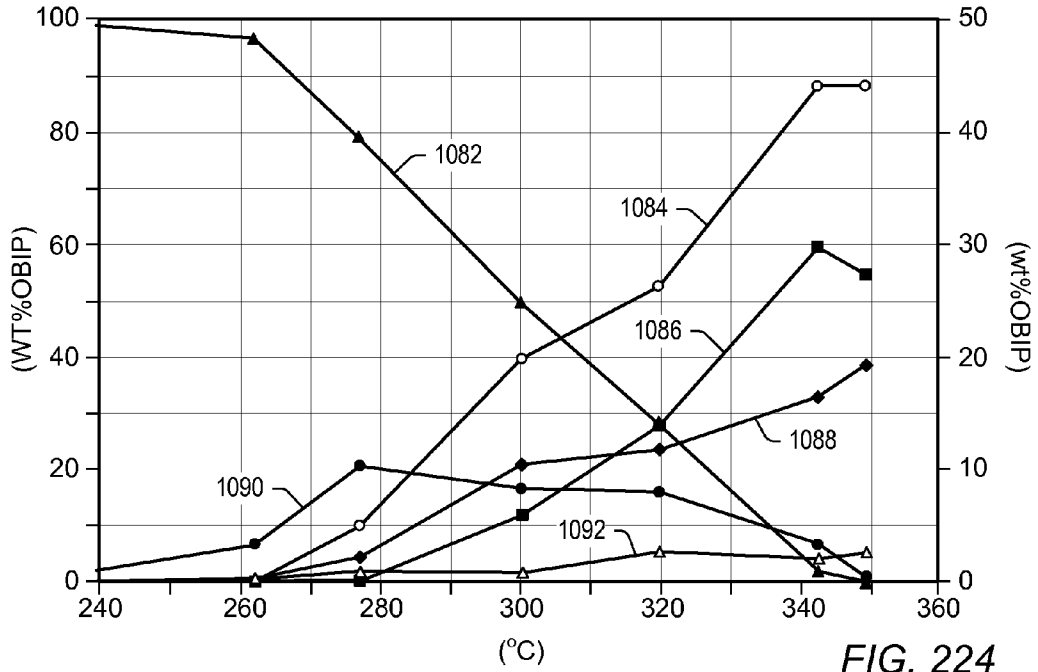

FIG. 224

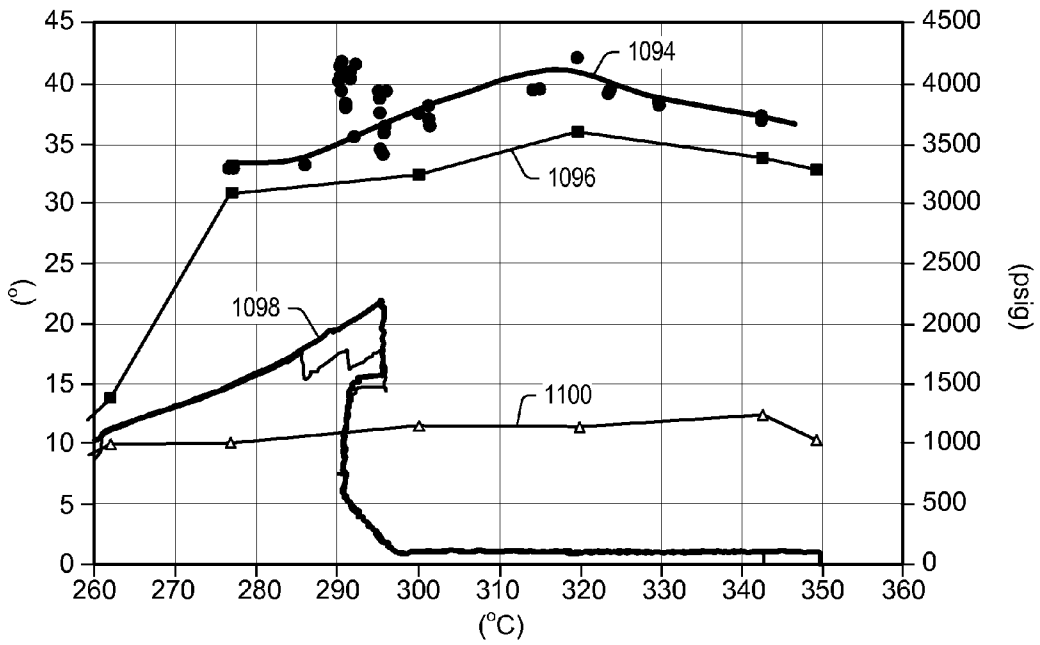
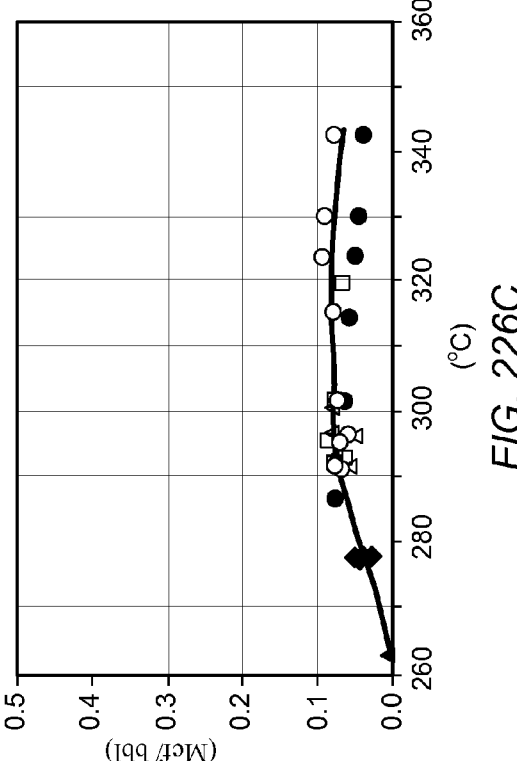
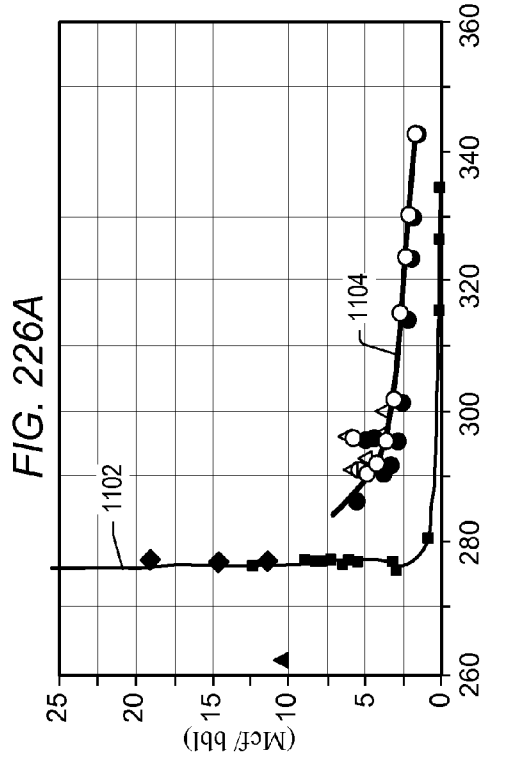
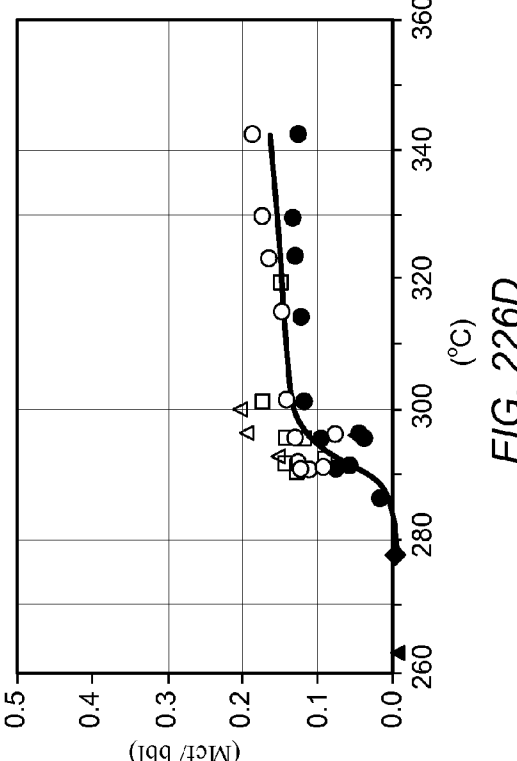
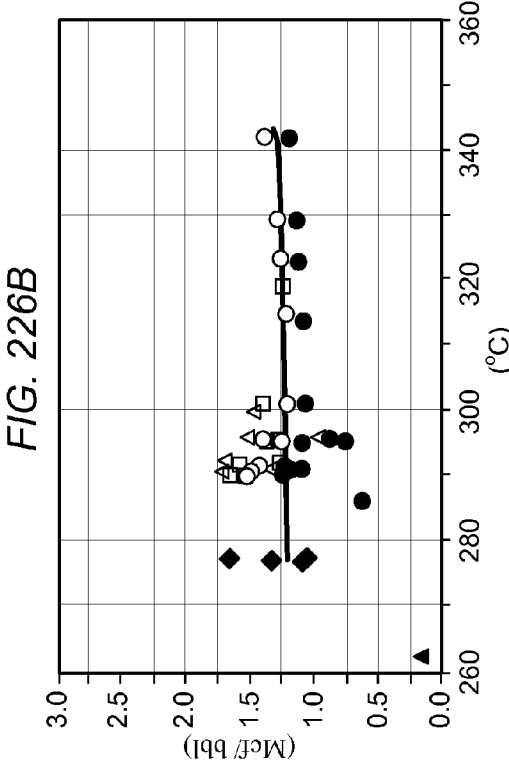

FIG. 225



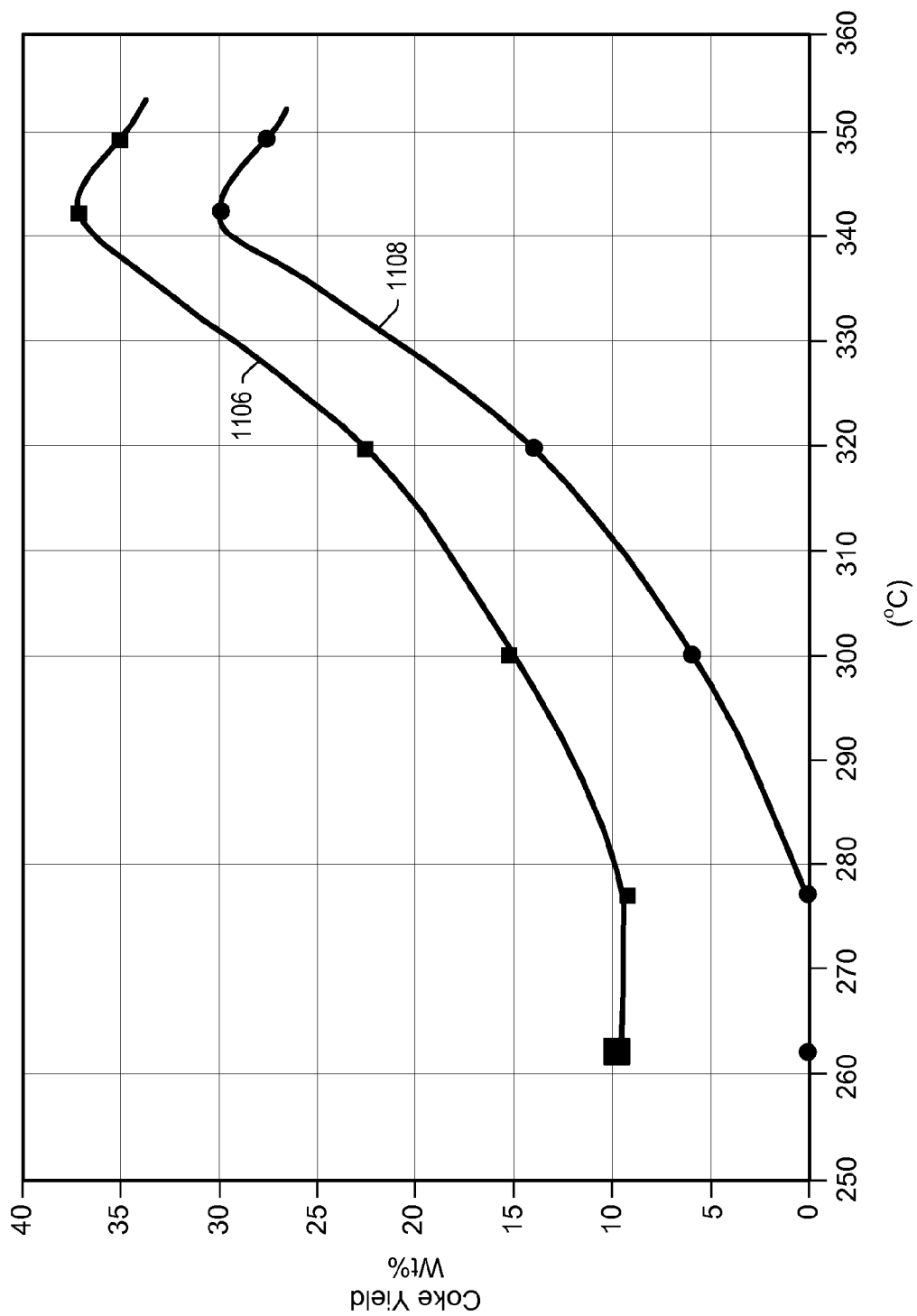

FIG. 227

FIG. 228B

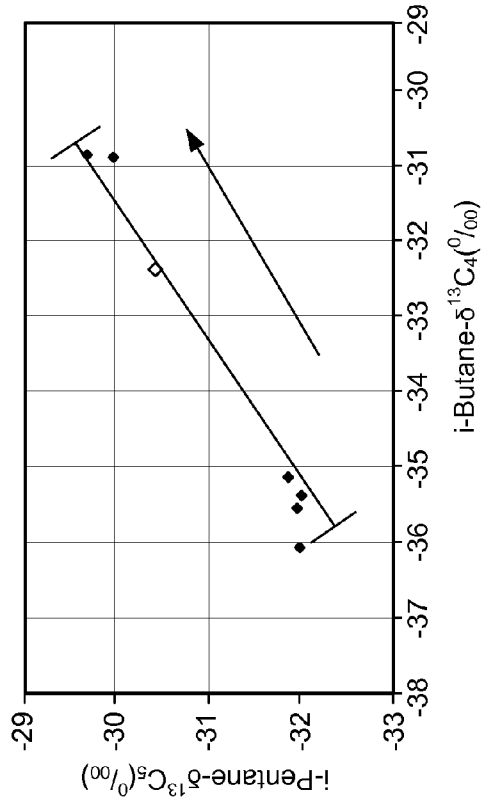
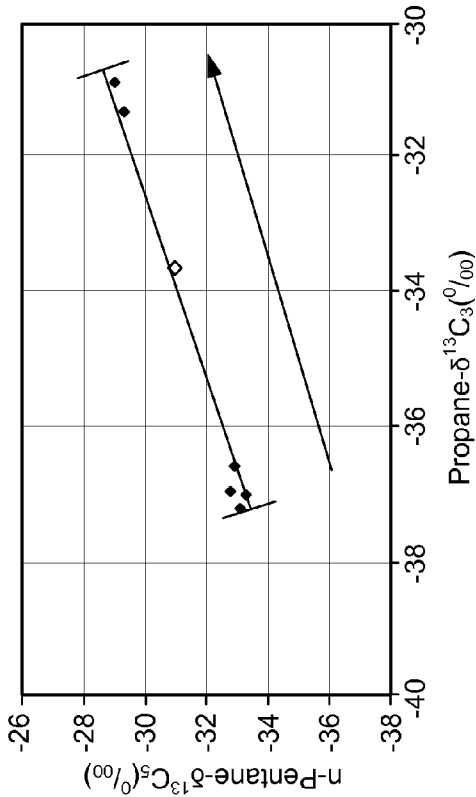

FIG. 228D

FIG. 228A

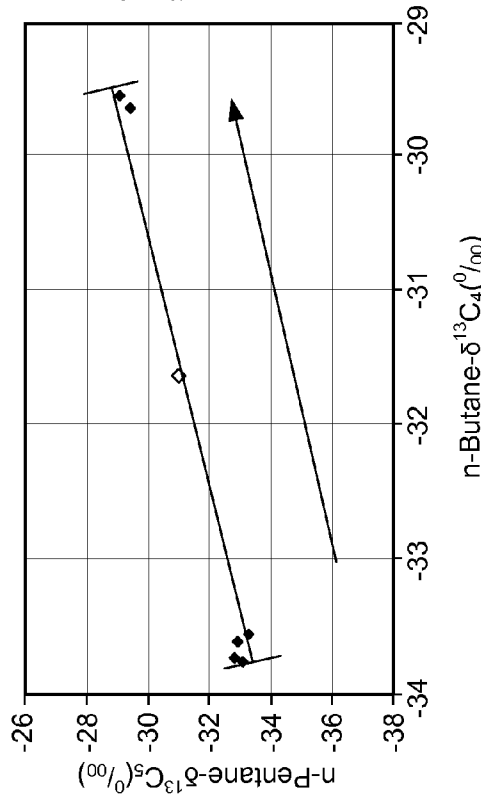
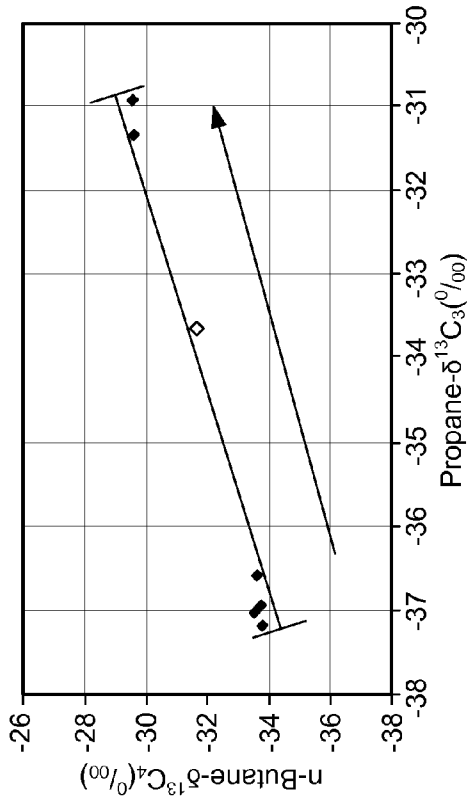

FIG. 228C

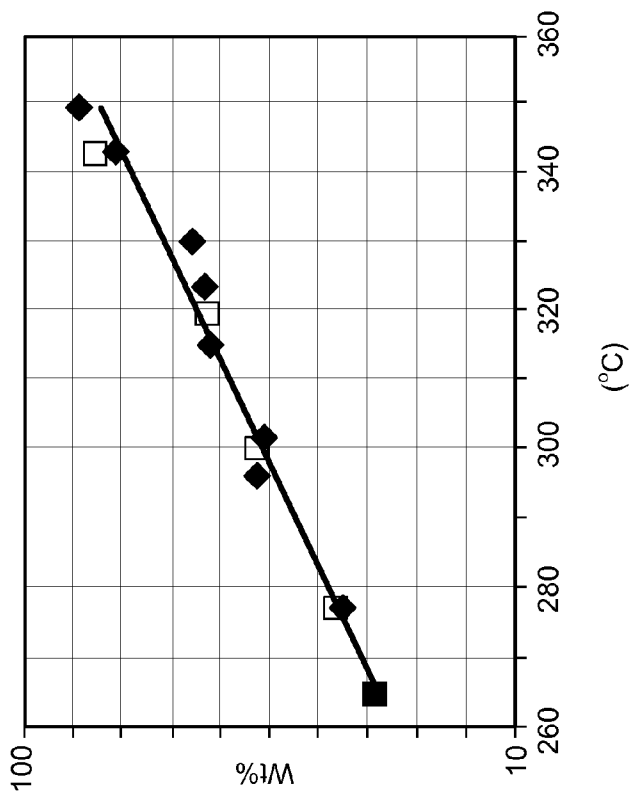

FIG. 230

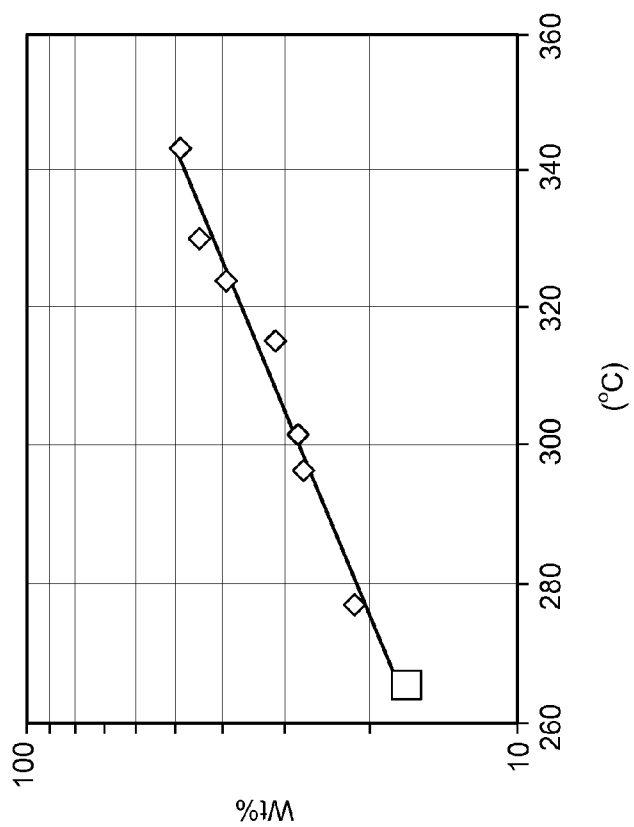

FIG. 229

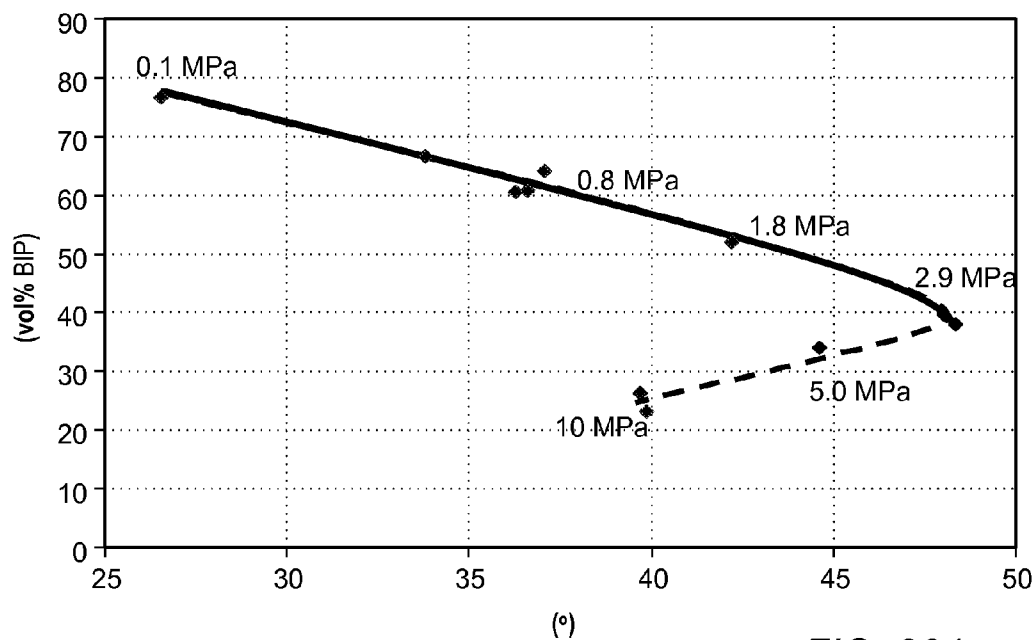

FIG. 231

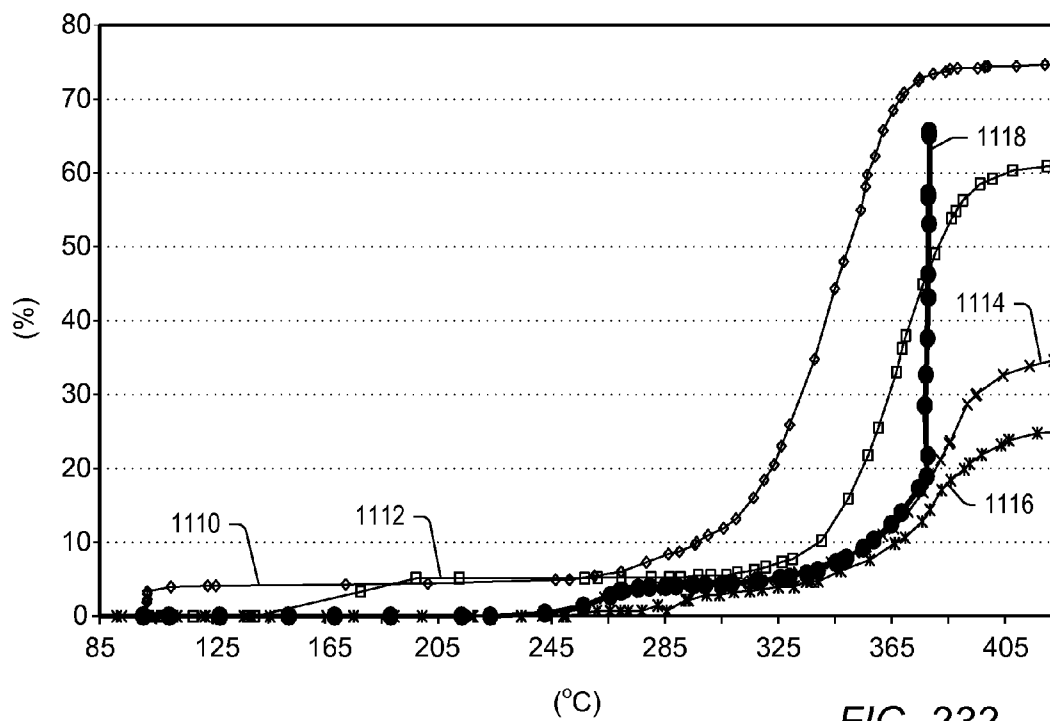

FIG. 232

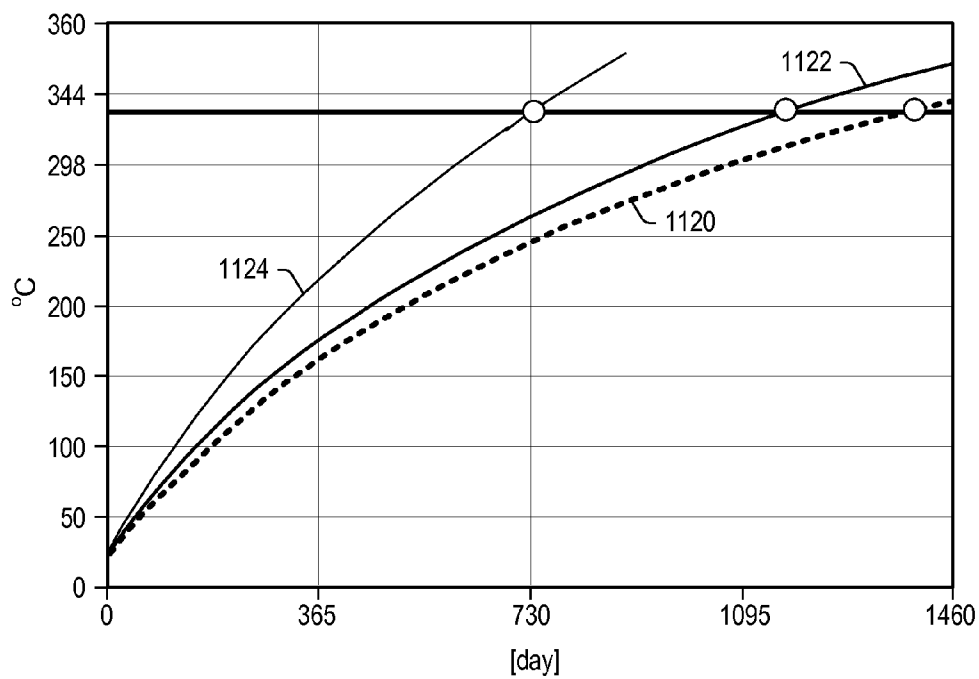

FIG. 233

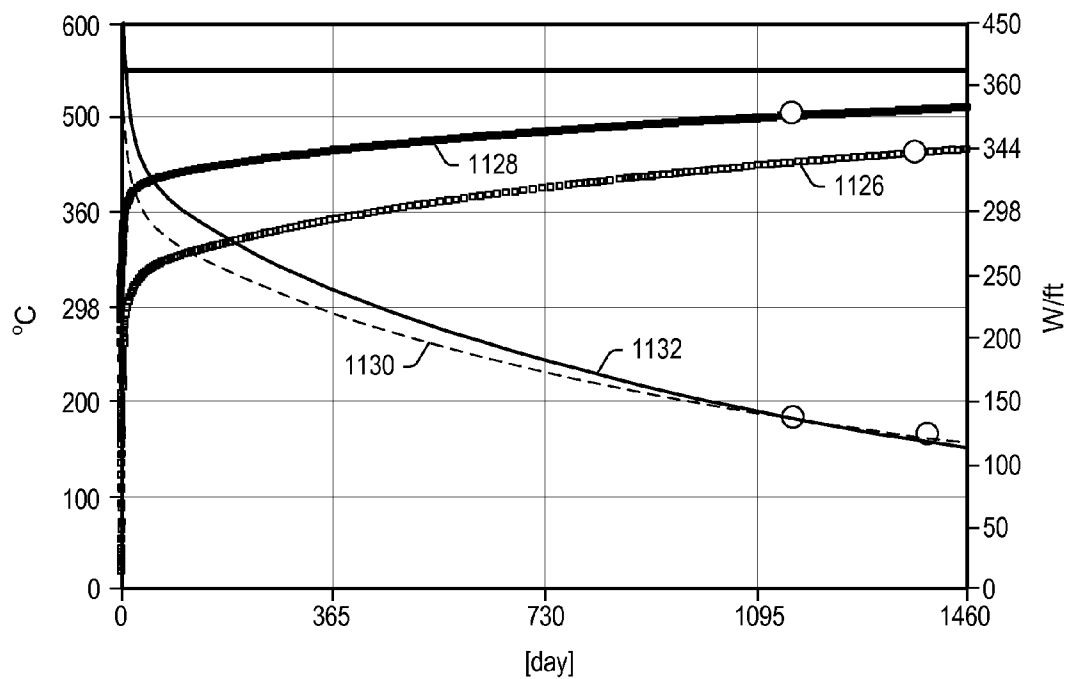

FIG. 234

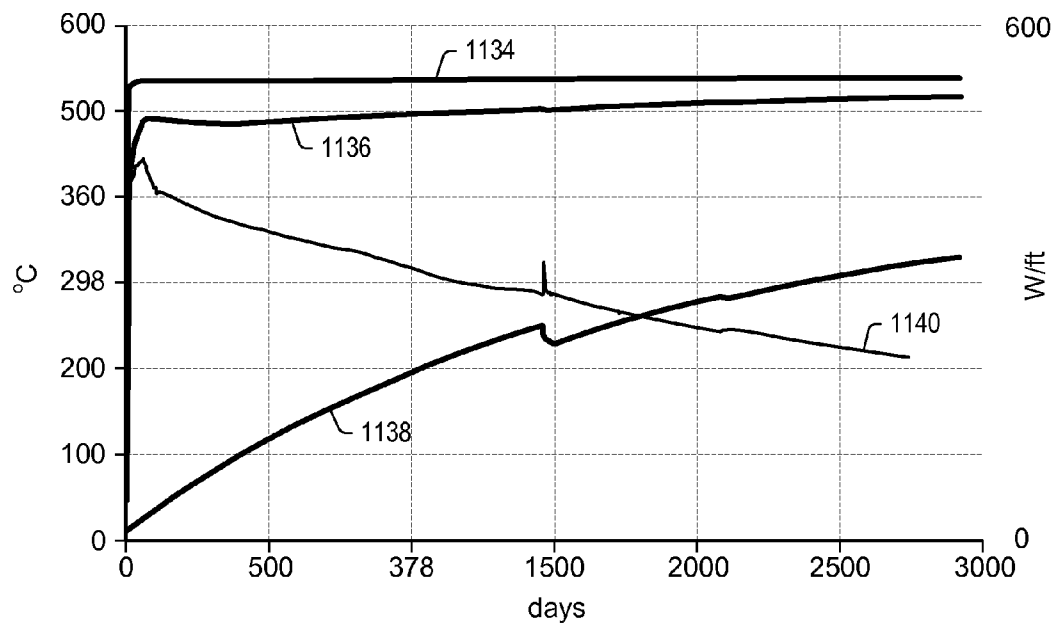

FIG. 235

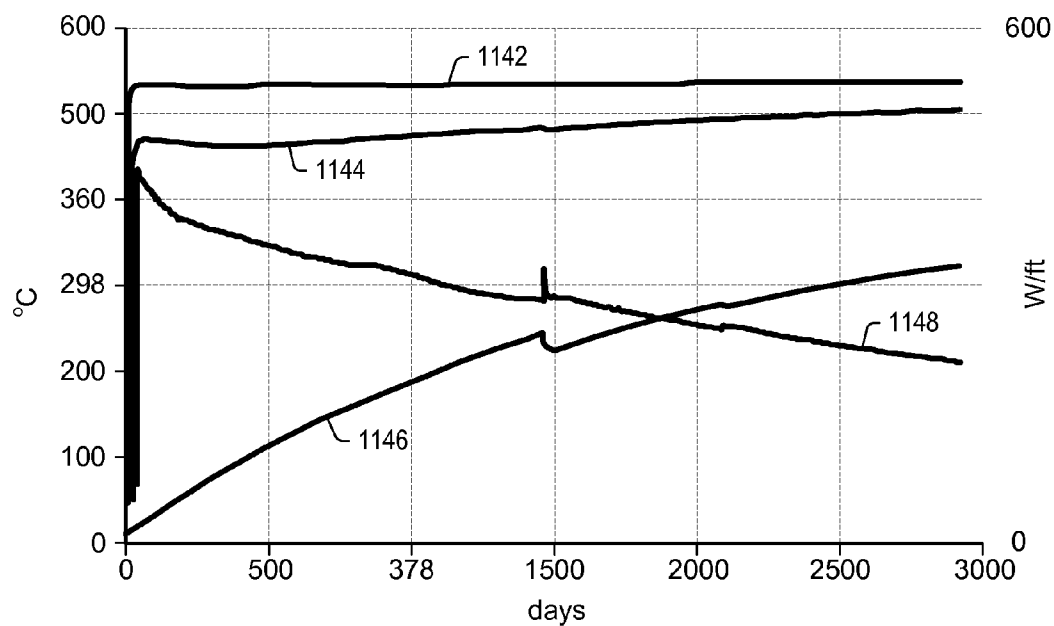

FIG. 236

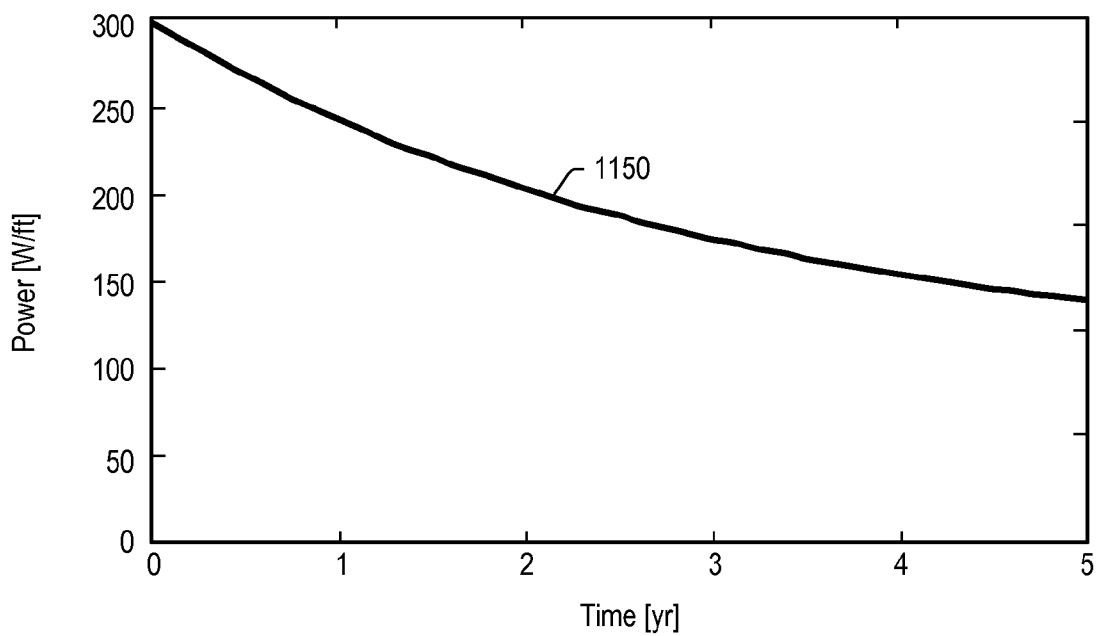

FIG. 237

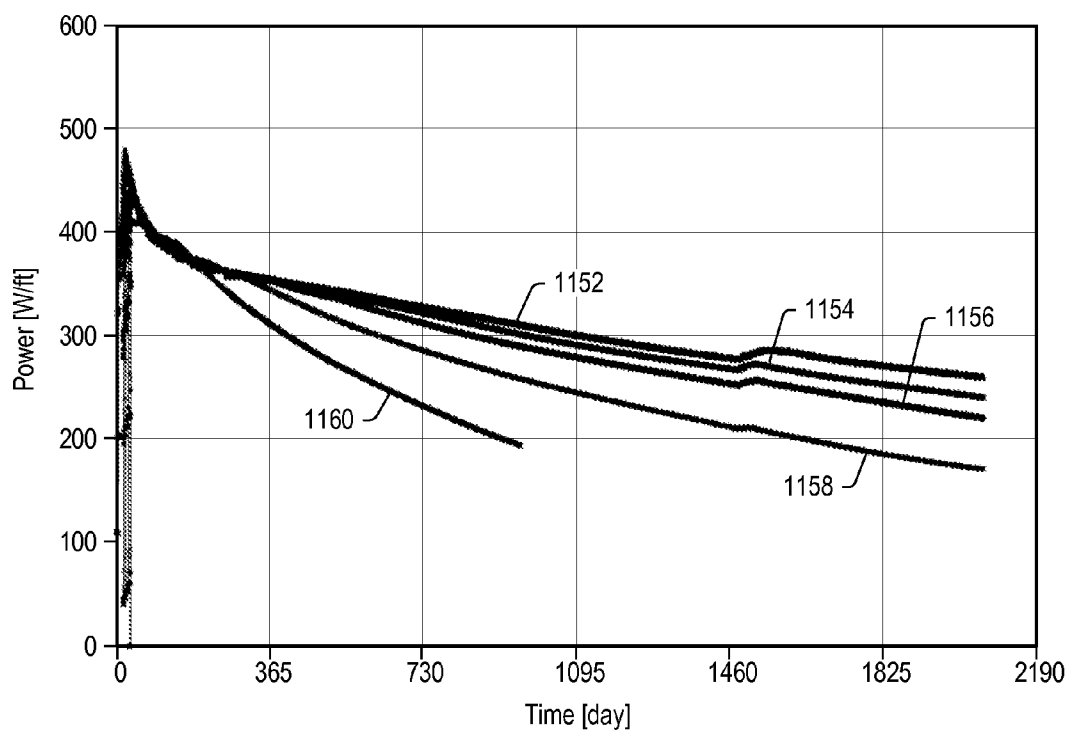

FIG. 238

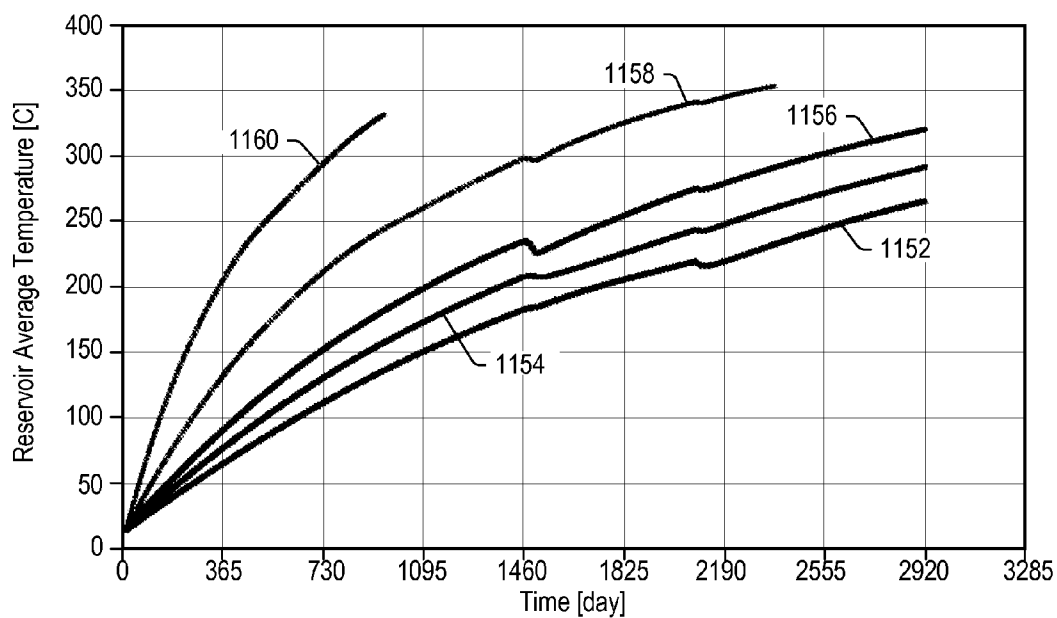

FIG. 239

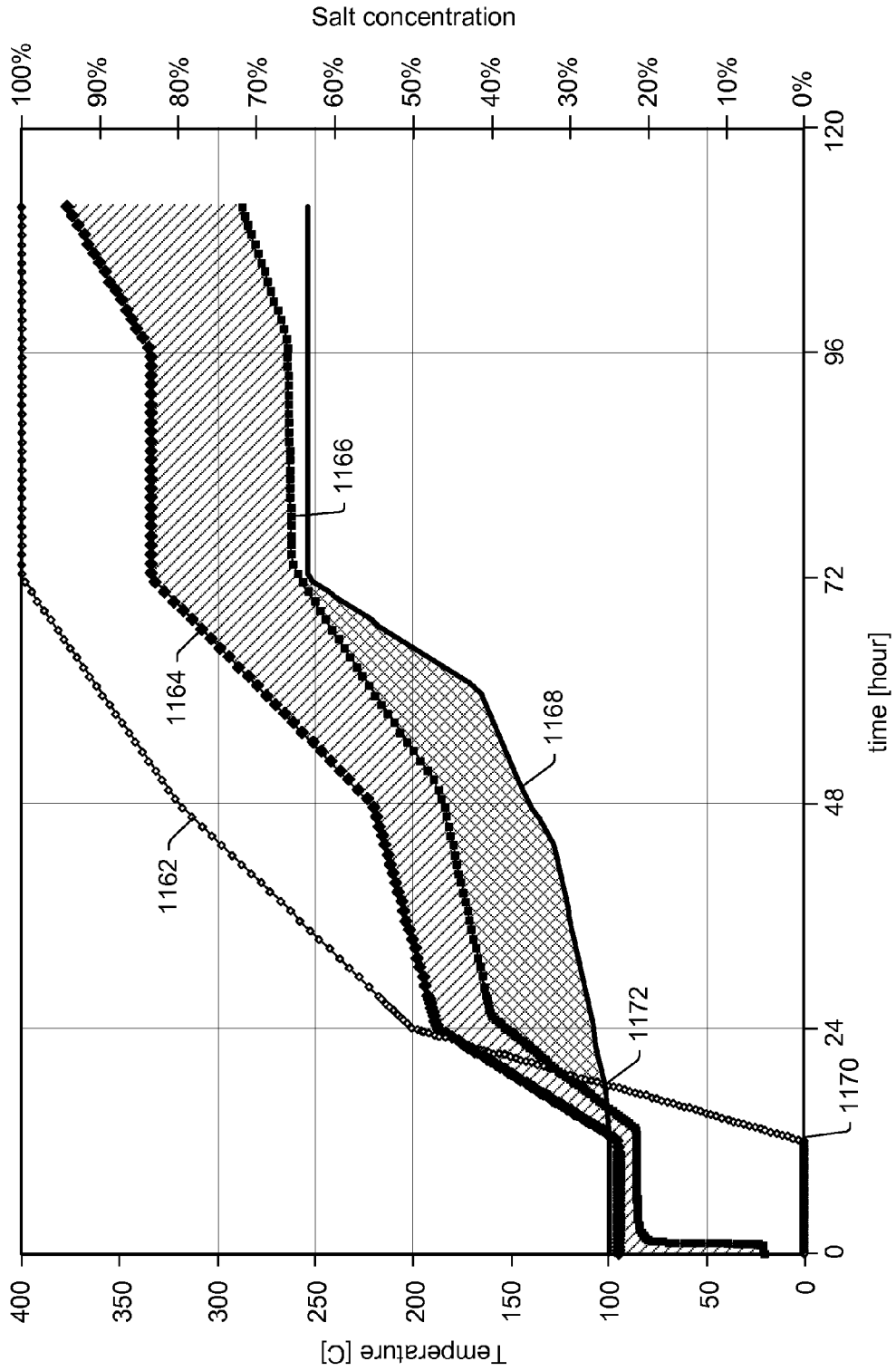

FIG. 240

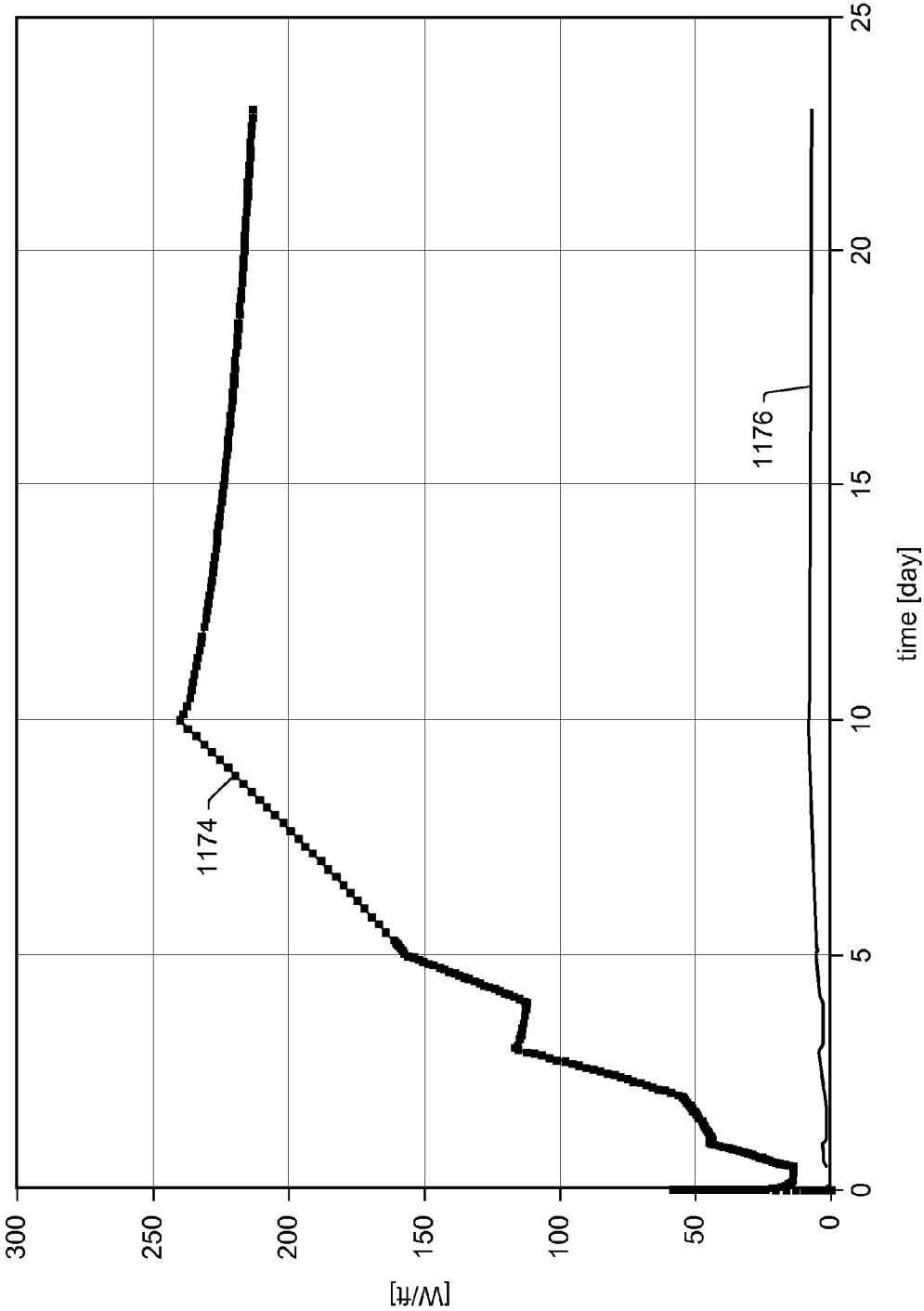

FIG. 241

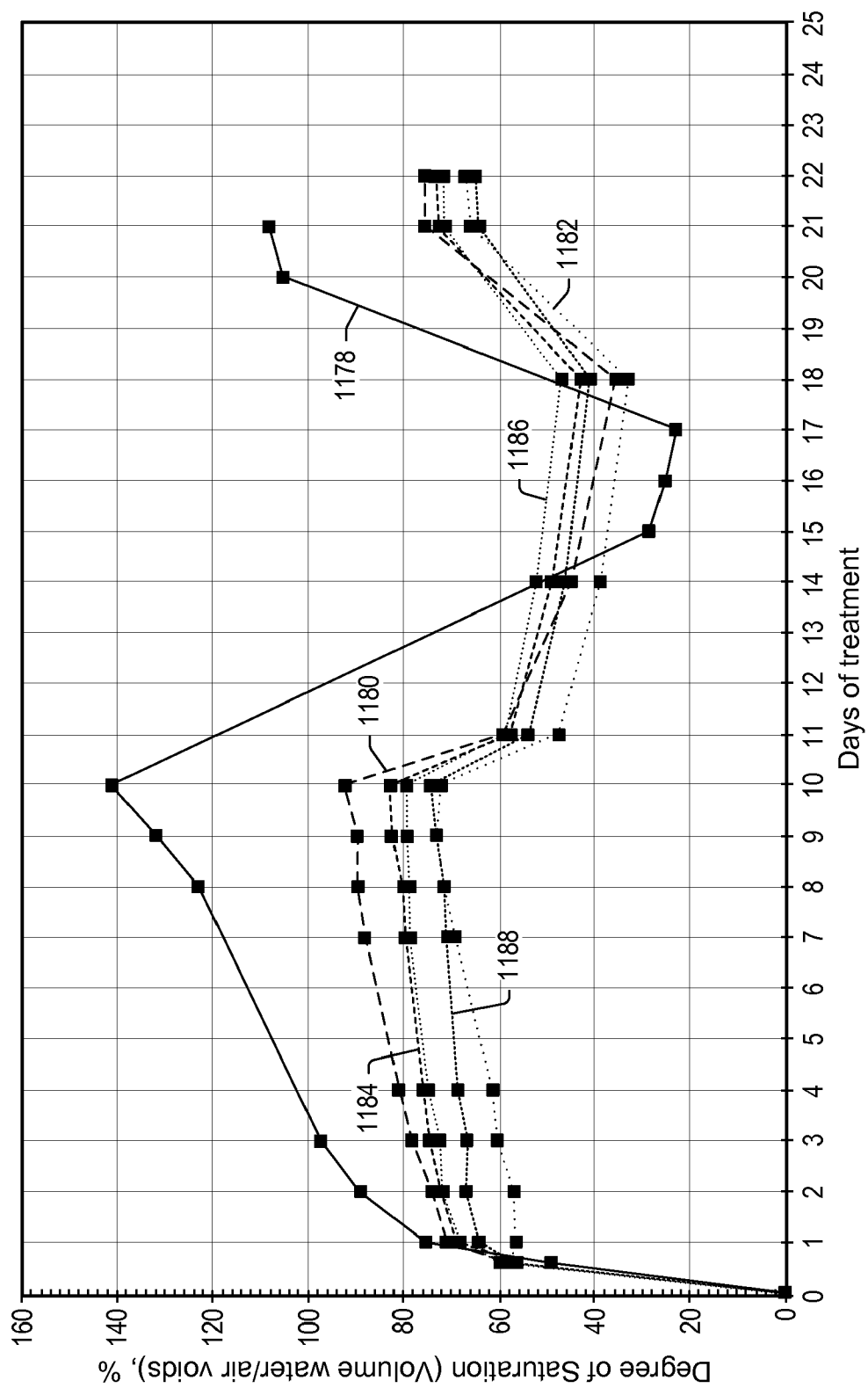

FIG. 242

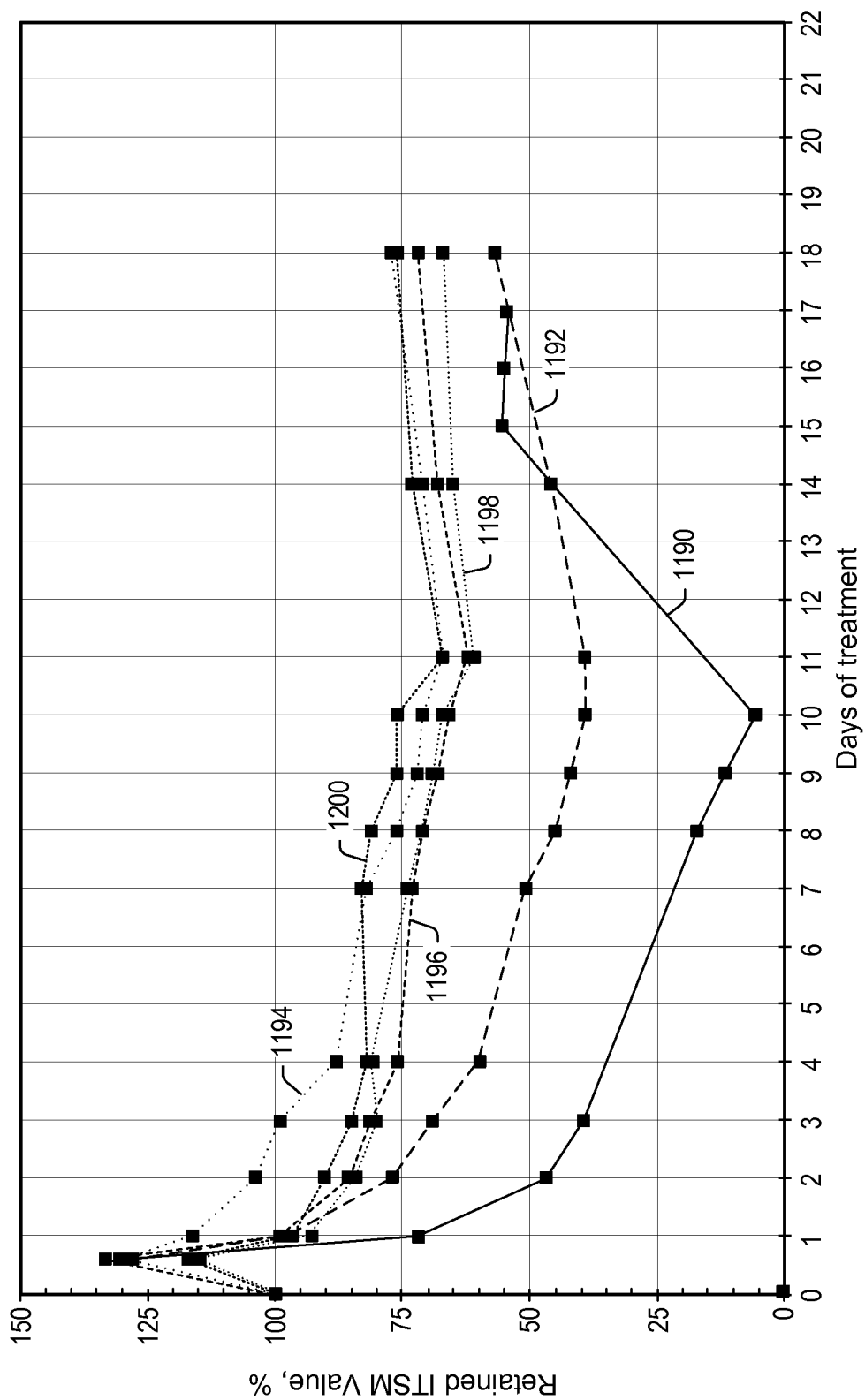

FIG. 243

**USING SELF-REGULATING NUCLEAR
REACTORS IN TREATING A SUBSURFACE
FORMATION**

PRIORITY CLAIM

[0001] This patent application claims priority to U.S. Provisional Patent No. 61/104,974 entitled "SYSTEMS, METHODS, AND PROCESSES UTILIZED FOR TREATING SUBSURFACE FORMATIONS" to Vinegar et al. filed on Oct. 13, 2008 and to U.S. Provisional Patent No. 61/168,498 entitled "SYSTEMS, METHODS, AND PROCESSES UTILIZED FOR TREATING SUBSURFACE HYDROCARBON CONTAINING FORMATIONS" to Vinegar et al. filed on Apr. 10, 2009.

RELATED PATENTS

[0002] This patent application incorporates by reference in its entirety each of U.S. Pat. No. 6,688,387 to Wellington et al.; U.S. Pat. No. 6,991,036 to Sumnu-Dindoruk et al.; U.S. Pat. No. 6,698,515 to Karanikas et al.; U.S. Pat. No. 6,880,633 to Wellington et al.; U.S. Pat. No. 6,782,947 to de Rouffignac et al.; U.S. Pat. No. 6,991,045 to Vinegar et al.; U.S. Pat. No. 7,073,578 to Vinegar et al.; U.S. Pat. No. 7,121,342 to Vinegar et al.; U.S. Pat. No. 7,320,364 to Fairbanks; U.S. Pat. No. 7,527,094 to McKinzie et al.; U.S. Pat. No. 7,584,789 to Mo et al.; U.S. Pat. No. 7,533,719 to Hinson et al.; and U.S. Pat. No. 7,562,707 to Miller. This patent application incorporates by reference in its entirety each of U.S. Patent Application Publication Nos. 2009-0071652 to Vinegar et al. and 2009-0189617 to Burns et al. This patent application incorporates by reference in its entirety U.S. patent application Ser. No. 12/422,088 to Prince-Wright et al.

BACKGROUND

[0003] 1. Field of the Invention

[0004] The present invention relates generally to methods and systems for production of hydrocarbons, hydrogen, and/or other products from various subsurface formations such as hydrocarbon containing formations.

[0005] 2. Description of Related Art

[0006] Hydrocarbons obtained from subterranean formations are often used as energy resources, as feedstocks, and as consumer products. Concerns over depletion of available hydrocarbon resources and concerns over declining overall quality of produced hydrocarbons have led to development of processes for more efficient recovery, processing and/or use of available hydrocarbon resources. In situ processes may be used to remove hydrocarbon materials from subterranean formations that were previously inaccessible and/or too expensive to extract using available methods. Chemical and/or physical properties of hydrocarbon material in a subterranean formation may need to be changed to allow hydrocarbon material to be more easily removed from the subterranean formation and/or increase the value of the hydrocarbon material. The chemical and physical changes may include in situ reactions that produce removable fluids, composition changes, solubility changes, density changes, phase changes, and/or viscosity changes of the hydrocarbon material in the formation.

[0007] Large deposits of heavy hydrocarbons (heavy oil and/or tar) contained in relatively permeable formations (for example in tar sands) are found in North America, South America, Africa, and Asia. Tar can be surface-mined and

upgraded to lighter hydrocarbons such as crude oil, naphtha, kerosene, and/or gas oil. Surface milling processes may further separate the bitumen from sand. The separated bitumen may be converted to light hydrocarbons using conventional refinery methods. Mining and upgrading tar sand is usually substantially more expensive than producing lighter hydrocarbons from conventional oil reservoirs.

[0008] Obtaining permeability in an oil shale formation between injection and production wells tends to be difficult because oil shale is often substantially impermeable. Drilling such wells may be expensive and time consuming. Many methods have attempted to link injection and production wells.

[0009] Many different types of wells or wellbores may be used to treat the hydrocarbon containing formation using an in situ heat treatment process. In some embodiments, vertical and/or substantially vertical wells are used to treat the formation. In some embodiments, horizontal or substantially horizontal wells (such as J-shaped wells and/or L-shaped wells), and/or u-shaped wells are used to treat the formation. In some embodiments, combinations of horizontal wells, vertical wells, and/or other combinations are used to treat the formation. In certain embodiments, wells extend through the overburden of the formation to a hydrocarbon containing layer of the formation. In some situations, heat in the wells is lost to the overburden. In some situations, surface and overburden infrastructures used to support heaters and/or production equipment in horizontal wellbores or u-shaped wellbores are large in size and/or numerous.

[0010] Wellbores for heater, injection, and/or production wells may be drilled by rotating a drill bit against the formation. The drill bit may be suspended in a borehole by a drill string that extends to the surface. In some cases, the drill bit may be rotated by rotating the drill string at the surface. Sensors may be attached to drilling systems to assist in determining direction, operating parameters, and/or operating conditions during drilling of a wellbore. Using the sensors may decrease the amount of time taken to determine positioning of the drilling systems. For example, U.S. Pat. No. 7,093,370 to Hansberry and U.S. Patent Application Publication No. 2009-027041 to Zaeper et al., both of which are incorporated herein by reference, describe a borehole navigation systems and/or sensors to drill wellbores in hydrocarbon formations. At present, however, there are still many hydrocarbon containing formations where drilling wellbores is difficult, expensive, and/or time consuming.

[0011] Heaters may be placed in wellbores to heat a formation during an in situ process. There are many different types of heaters which may be used to heat the formation. Examples of in situ processes utilizing downhole heaters are illustrated in U.S. Pat. No. 2,634,961 to Ljungstrom; U.S. Pat. No. 2,732,195 to Ljungstrom; U.S. Pat. No. 2,780,450 to Ljungstrom; U.S. Pat. No. 2,789,805 to Ljungstrom; U.S. Pat. No. 2,923,535 to Ljungstrom; U.S. Pat. No. 4,886,118 to Van Meurs et al.; and U.S. Pat. No. 6,688,387 to Wellington et al.; each of which is incorporated by reference as if fully set forth herein.

[0012] U.S. Pat. No. 7,575,052 to Sandberg et al. and U.S. Patent Application Publication No. 2008-0135254 to Vinegar et al., each of which are incorporated herein by reference, describe an in situ heat treatment process that utilizes a circulation system to heat one or more treatment areas. The

circulation system may use a heated liquid heat transfer fluid that passes through piping in the formation to transfer heat to the formation.

[0013] Patent Application Publication No. 2009-0095476 to Nguyen et al., which is incorporated herein by reference, describes a heating system for a subsurface formation that includes a conduit located in an opening in the subsurface formation. An insulated conductor is located in the conduit. A material is in the conduit between a portion of the insulated conductor and a portion of the conduit. The material may be a salt. The material is a fluid at operating temperature of the heating system. Heat transfers from the insulated conductor to the fluid, from the fluid to the conduit, and from the conduit to the subsurface formation.

[0014] In situ production of hydrocarbons from tar sand may be accomplished by heating and/or injecting fluids into the formation. U.S. Pat. No. 4,084,637 to Todd; U.S. Pat. No. 4,926,941 to Glandt et al.; U.S. Pat. No. 5,046,559 to Glandt, and U.S. Pat. No. 5,060,726 to Glandt, each of which are incorporated herein by reference, describe methods of producing viscous materials from subterranean formations that includes passing electrical current through the subterranean formation. Steam may be injected from the injector well into the formation to produce hydrocarbons.

[0015] U.S. Pat. No. 3,170,842 to Kehler, which is incorporated herein by reference, describes a subcritical, nuclear reactor and neutron-producing means as a heat source.

[0016] U.S. Pat. No. 3,237,689 to Justheim and U.S. Pat. No. 3,766,982 to Justheim, both of which are incorporated herein by reference, describe methods of using a nuclear reactor to provide heat to a heat-exchange medium. U.S. Pat. No. 3,598,182 to Justheim, which is incorporated herein by reference, describes a method of obtaining hot hydrogen from a nuclear reactor utilizing hydrogen as a coolant. The hot hydrogen is used to carry the heat and to hydrogenate kerosene.

[0017] U.S. Pat. No. 4,930,574 to Jager, which is incorporated herein by reference, describes a method for tertiary oil recovery and gas utilization by the introduction of nuclear-heated steam into an oil field and the removal, separation and preparation of an escaping oil-gas-water mixture.

[0018] U.S. Patent Application Publication No. 20070181301 to O'Brien, which is incorporated herein by reference, describes a system and method using nuclear energy sources for energy to fracture the oil shale formations and provide sufficient heat and pressure to produce liquid and gaseous hydrocarbon products.

[0019] As discussed above, there has been a significant amount of effort to develop methods and systems to economically produce hydrocarbons, hydrogen, and/or other products from hydrocarbon containing formations. At present, however, there are still many hydrocarbon containing formations from which hydrocarbons, hydrogen, and/or other products cannot be economically produced. Thus, there is a need for improved methods and systems for heating of a hydrocarbon formation and production of fluids from the hydrocarbon formation. There is also a need for improved methods and systems that reduce energy costs for treating the formation, reduce emissions from the treatment process, facilitate heating system installation, and/or reduce heat loss to the overburden as compared to hydrocarbon recovery processes that utilize surface based equipment.

SUMMARY

[0020] Embodiments described herein generally relate to systems, methods, and heaters for treating a subsurface for-

mation. Embodiments described herein also generally relate to heaters that have novel components therein. Such heaters can be obtained by using the systems and methods described herein.

[0021] In certain embodiments, the invention provides one or more systems, methods, and/or heaters. In some embodiments, the systems, methods, and/or heaters are used for treating a subsurface formation.

[0022] In certain embodiments, an in situ heat treatment system for producing hydrocarbons from a subsurface formation includes: a plurality of wellbores in the formation; at least one heater positioned in at least two of the wellbores; and a self-regulating nuclear reactor configured to provide energy to at least one of the heaters to increase the temperature of at least a portion of the formation to temperatures that allow for hydrocarbon production from the formation; wherein heat input to at least a portion of the formation over time at least approximately correlates to a rate of decay of the power from the self-regulating nuclear reactor.

[0023] In certain embodiments, a method of producing hydrocarbons from a subsurface formation includes: forming a plurality of wellbores in the formation; positioning at least one heater in at least two of the wellbores; providing energy to at least one of the heaters to heat the temperature of the formation to temperatures that allow for hydrocarbon production from the formation using a self-regulating nuclear reactor; and at least approximately correlating heat input to at least a portion of the formation over time to a rate of decay of the power from the self-regulating nuclear reactor.

[0024] In further embodiments, features from specific embodiments may be combined with features from other embodiments. For example, features from one embodiment may be combined with features from any of the other embodiments.

[0025] In further embodiments, treating a subsurface formation is performed using any of the methods, systems, or heaters described herein.

[0026] In further embodiments, additional features may be added to the specific embodiments described herein.

BRIEF DESCRIPTION OF THE DRAWINGS

[0027] Advantages of the present invention may become apparent to those skilled in the art with the benefit of the following detailed description and upon reference to the accompanying drawings in which:

[0028] FIG. 1 shows a schematic view of an embodiment of a portion of an in situ heat treatment system for treating a hydrocarbon containing formation.

[0029] FIG. 2 depicts a schematic representation of an embodiment of a system for treating a liquid stream produced from an in situ heat treatment process.

[0030] FIG. 3 depicts a schematic representation of an embodiment of a system for treating the mixture produced from an in situ heat treatment process.

[0031] FIG. 4 depicts a schematic representation of an embodiment of a system for forming and transporting tubing to a treatment area.

[0032] FIG. 5 depicts an embodiment of a drilling string with dual motors on a bottom hole assembly.

[0033] FIG. 6 depicts a schematic representation of an embodiment of a drilling string including a motor.

[0034] FIG. 7 depicts time versus rpm (revolutions per minute) for an embodiment of a conventional steerable motor bottom hole assembly during a drill bit direction change.

- [0035] FIG. 8 depicts time versus rpm for an embodiment of a dual motor bottom hole assembly during a drill bit direction change.
- [0036] FIG. 9 depicts an embodiment of a drilling string with a non-rotating sensor.
- [0037] FIG. 10 depicts a schematic of an embodiment of a rack and pinion drilling system.
- [0038] FIGS. 11A through 11D depict schematics of an embodiment for a continuous drilling sequence.
- [0039] FIG. 12 depicts a cut-away view of an embodiment of a circulating sleeve of the bottom drive system depicted in FIGS. 11A-11D.
- [0040] FIG. 13 depicts a schematic of the valve system of the circulating sleeve of the bottom drive system depicted in FIGS. 11A-11D.
- [0041] FIG. 14 depicts a schematic of an embodiment of a first group of barrier wells used to form a first barrier and a second group of barrier wells used to form a second barrier.
- [0042] FIGS. 15, 16, and 17 depict cross-sectional representations of an embodiment of a temperature limited heater with an outer conductor having a ferromagnetic section and a non-ferromagnetic section.
- [0043] FIGS. 18, 19, 20, and 21 depict cross-sectional representations of an embodiment of a temperature limited heater with an outer conductor having a ferromagnetic section and a non-ferromagnetic section placed inside a sheath.
- [0044] FIGS. 22A and 22B depict cross-sectional representations of an embodiment of a temperature limited heater.
- [0045] FIG. 23 depicts a cross-sectional representation of an embodiment of a composite conductor with a support member.
- [0046] FIG. 24 depicts a cross-sectional representation of an embodiment of a composite conductor with a support member separating the conductors.
- [0047] FIG. 25 depicts a cross-sectional representation of an embodiment of a composite conductor surrounding a support member.
- [0048] FIG. 26 depicts a cross-sectional representation of an embodiment of a composite conductor surrounding a conduit support member.
- [0049] FIG. 27 depicts a cross-sectional representation of an embodiment of a conductor-in-conduit heat source.
- [0050] FIG. 28 depicts a cross-sectional representation of an embodiment of a removable conductor-in-conduit heat source.
- [0051] FIG. 29 depicts a cross-sectional representation of an embodiment of a temperature limited heater in which the support member provides a majority of the heat output below the Curie temperature of the ferromagnetic conductor.
- [0052] FIGS. 30 and 31 depict cross-sectional representations of embodiments of temperature limited heaters in which the jacket provides a majority of the heat output below the Curie temperature of the ferromagnetic conductor.
- [0053] FIGS. 32A and 32B depict cross-sectional representations of an embodiment of a temperature limited heater component used in an insulated conductor heater.
- [0054] FIG. 33 depicts a top view representation of three insulated conductors in a conduit.
- [0055] FIG. 34 depicts an embodiment of three-phase wye transformer coupled to a plurality of heaters.
- [0056] FIG. 35 depicts a side view representation of an embodiment of an end section of three insulated conductors in a conduit.
- [0057] FIG. 36 depicts an embodiment of a heater with three insulated cores in a conduit.
- [0058] FIG. 37 depicts an embodiment of a heater with three insulated conductors and an insulated return conductor in a conduit.
- [0059] FIG. 38 depicts a side view cross-sectional representation of one embodiment of a fitting for joining insulated conductors.
- [0060] FIG. 39 depicts an embodiment of a cutting tool.
- [0061] FIG. 40 depicts a side view cross-sectional representation of another embodiment of a fitting for joining insulated conductors.
- [0062] FIG. 41A depicts a side view of a cross-sectional representation of an embodiment of a threaded fitting for coupling three insulated conductors.
- [0063] FIG. 41B depicts a side view of a cross-sectional representation of an embodiment of a welded fitting for coupling three insulated conductors.
- [0064] FIG. 42 depicts an embodiment of a torque tool.
- [0065] FIG. 43 depicts an embodiment of a clamp assembly that may be used to compact mechanically a fitting for joining insulated conductors.
- [0066] FIG. 44 depicts an exploded view of an embodiment of a hydraulic compaction machine.
- [0067] FIG. 45 depicts a representation of an embodiment of an assembled hydraulic compaction machine.
- [0068] FIG. 46 depicts an embodiment of a fitting and insulated conductors secured in clamp assemblies before compaction of the fitting and insulated conductors.
- [0069] FIG. 47 depicts a side view representation of yet another embodiment of a fitting for joining insulated conductors.
- [0070] FIG. 48 depicts a side view representation of an embodiment of a fitting with an opening covered with an insert.
- [0071] FIG. 49 depicts an embodiment of a fitting with electric field reducing features between the jackets of the insulated conductors and the sleeves and at the ends of the insulated conductors.
- [0072] FIG. 50 depicts an embodiment of an electric field stress reducer.
- [0073] FIG. 51 depicts an embodiment of an outer tubing partially unspooled from a coiled tubing rig.
- [0074] FIG. 52 depicts an embodiment of a heater being pushed into outer tubing partially unspooled from a coiled tubing rig.
- [0075] FIG. 53 depicts an embodiment of a heater being fully inserted into outer tubing with a drilling guide coupled to the end of the heater.
- [0076] FIG. 54 depicts an embodiment of a heater, outer tubing, and drilling guide spooled onto a coiled tubing rig.
- [0077] FIG. 55 depicts an embodiment of a coiled tubing rig being used to install a heater and outer tubing into an opening using a drilling guide.
- [0078] FIG. 56 depicts an embodiment of a heater and outer tubing installed in an opening.
- [0079] FIG. 57 depicts an embodiment of outer tubing being removed from an opening while leaving a heater installed in the opening.
- [0080] FIG. 58 depicts an embodiment of outer tubing used to provide a packing material into an opening.
- [0081] FIG. 59 depicts a schematic of an embodiment of outer tubing being spooled onto a coiled tubing rig after packing material is provided into an opening.

- [0082] FIG. 60 depicts a schematic of an embodiment of outer tubing spooled onto a coiled tubing rig with a heater installed in an opening.
- [0083] FIG. 61 depicts an embodiment of a heater installed in an opening with a wellhead.
- [0084] FIG. 62 depicts a cross-sectional representation of an embodiment of an insulated conductor in a conduit with liquid between the insulated conductor and the conduit.
- [0085] FIG. 63 depicts a cross-sectional representation of an embodiment of an insulated conductor heater in a conduit with a conductive liquid between the insulated conductor and the conduit.
- [0086] FIG. 64 depicts a schematic representation of an embodiment of an insulated conductor in a conduit with liquid between the insulated conductor and the conduit, where a portion of the conduit and the insulated conductor are oriented horizontally in the formation.
- [0087] FIG. 65 depicts a cross-sectional representation of an embodiment of a ribbed conduit.
- [0088] FIG. 66 depicts a perspective representation of an embodiment of a portion of a ribbed conduit.
- [0089] FIG. 67 depicts a cross-sectional representation an embodiment of a portion of an insulated conductor in a bottom portion of an open wellbore with a liquid between the insulated conductor and the formation.
- [0090] FIG. 68 depicts a schematic cross-sectional representation of an embodiment of a portion of a formation with heat pipes positioned adjacent to a substantially horizontal portion of a heat source.
- [0091] FIG. 69 depicts a perspective cut-out representation of a portion of a heat pipe embodiment with the heat pipe located radially around an oxidizer assembly.
- [0092] FIG. 70 depicts a cross-sectional representation of an angled heat pipe embodiment with an oxidizer assembly located near a lowermost portion of the heat pipe.
- [0093] FIG. 71 depicts a perspective cut-out representation of a portion of a heat pipe embodiment with an oxidizer located at the bottom of the heat pipe.
- [0094] FIG. 72 depicts a cross-sectional representation of an angled heat pipe embodiment with an oxidizer located at the bottom of the heat pipe.
- [0095] FIG. 73 depicts a perspective cut-out representation of a portion of a heat pipe embodiment with an oxidizer that produces a flame zone adjacent to liquid heat transfer fluid in the bottom of the heat pipe.
- [0096] FIG. 74 depicts a perspective cut-out representation of a portion of a heat pipe embodiment with a tapered bottom that accommodates multiple oxidizers.
- [0097] FIG. 75 depicts a cross-sectional representation of a heat pipe embodiment that is angled within the formation.
- [0098] FIG. 76 depicts an embodiment of three heaters coupled in a three-phase configuration.
- [0099] FIG. 77 depicts a side view representation of an embodiment of a substantially u-shaped three-phase heater in a formation.
- [0100] FIG. 78 depicts a top view representation of an embodiment of a plurality of triads of three-phase heaters in a formation.
- [0101] FIG. 79 depicts a top view representation of an embodiment of a plurality of triads of three-phase heaters in a formation with production wells.
- [0102] FIG. 80 depicts a schematic of an embodiment of a heat treatment system that includes a heater and production wells.
- [0103] FIG. 81 depicts a side view representation of one leg of a heater in the subsurface formation.
- [0104] FIG. 82 depicts a schematic representation of an embodiment of a surface cabling configuration with a ground loop used for a heater and a production well.
- [0105] FIG. 83 depicts a side view representation of an embodiment of an overburden portion of a conductor.
- [0106] FIG. 84 depicts a side view representation of an embodiment of overburden portions of conductors grounded to a ground loop.
- [0107] FIG. 85 depicts a side view representation of an embodiment of overburden portions of conductors with the conductors ungrounded.
- [0108] FIG. 86 depicts a side view representation of an embodiment of overburden portions of conductors with the electrically conductive portions of casings lowered a selected depth below the surface.
- [0109] FIG. 87 depicts a cross-sectional representation of an embodiment of a heater including nine single-phase flexible cable conductors positioned between tubulars.
- [0110] FIG. 88 depicts a cross-sectional representation of an embodiment of a heater including nine single-phase flexible cable conductors positioned between tubulars with spacers.
- [0111] FIG. 89 depicts a cross-sectional representation of an embodiment of a heater including nine multiple flexible cable conductors positioned between tubulars.
- [0112] FIG. 90 depicts a cross-sectional representation of an embodiment of a heater including nine multiple flexible cable conductors positioned between tubulars with spacers.
- [0113] FIG. 91 depicts an embodiment of a wellhead.
- [0114] FIG. 92 depicts an example of a plot of dielectric constant versus temperature for magnesium oxide insulation in one embodiment of an insulated conductor heater.
- [0115] FIG. 93 depicts an example of a plot of loss tangent ($\tan \delta$) versus temperature for magnesium oxide insulation in one embodiment of an insulated conductor heater.
- [0116] FIG. 94 depicts an example of a plot of leakage current (mA) versus temperature ($^{\circ}$ F.) for magnesium oxide insulation in one embodiment of an insulated conductor heater at different applied voltages.
- [0117] FIG. 95 depicts an embodiment of an insulated conductor with salt used as electrical insulator.
- [0118] FIG. 96 depicts an embodiment of an insulated conductor located proximate heaters in a wellbore.
- [0119] FIG. 97 depicts an embodiment of an insulated conductor with voltage applied to the core and the jacket of the insulated conductor.
- [0120] FIG. 98 depicts an embodiment of an insulated conductor with multiple hot spots.
- [0121] FIG. 99 depicts a side view representation of an embodiment for producing mobilized fluids from a tar sands formation with a relatively thin hydrocarbon layer.
- [0122] FIG. 100 depicts a side view representation of an embodiment for producing mobilized fluids from a tar sands formation with a hydrocarbon layer that is thicker than the hydrocarbon layer depicted in FIG. 99.
- [0123] FIG. 101 depicts a side view representation of an embodiment for producing mobilized fluids from a tar sands formation with a hydrocarbon layer that is thicker than the hydrocarbon layer depicted in FIG. 100.
- [0124] FIG. 102 depicts a side view representation of an embodiment for producing mobilized fluids from a tar sands formation with a hydrocarbon layer that has a shale break.

[0125] FIG. 103 depicts a top view representation of an embodiment for preheating using heaters for the drive process.

[0126] FIG. 104 depicts a perspective representation of an embodiment for preheating using heaters for the drive process.

[0127] FIG. 105 depicts a side view representation of an embodiment of a tar sands formation subsequent to a steam injection process.

[0128] FIG. 106 depicts a side view representation of an embodiment using at least three treatment sections in a tar sands formation.

[0129] FIG. 107 depicts an embodiment for treating a formation with heaters in combination with one or more steam drive processes.

[0130] FIG. 108 depicts a comparison treating the formation using the embodiment depicted in FIG. 107 and treating the formation using the SAGD process.

[0131] FIG. 109 depicts an embodiment for heating and producing from a formation with a temperature limited heater in a production wellbore.

[0132] FIG. 110 depicts an embodiment for heating and producing from a formation with a temperature limited heater and a production wellbore.

[0133] FIG. 111 depicts a schematic of an embodiment of a first stage of treating a tar sands formation with electrical heaters.

[0134] FIG. 112 depicts a schematic of an embodiment of a second stage of treating the tar sands formation with fluid injection and oxidation.

[0135] FIG. 113 depicts a schematic of an embodiment of a third stage of treating the tar sands formation with fluid injection and oxidation.

[0136] FIG. 114 depicts a side view representation of a first stage of an embodiment of treating portions in a subsurface formation with heating, oxidation, and/or fluid injection.

[0137] FIG. 115 depicts a side view representation of a second stage of an embodiment of treating portions in the subsurface formation with heating, oxidation, and/or fluid injection.

[0138] FIG. 116 depicts a side view representation of a third stage of an embodiment of treating portions in subsurface formation with heating, oxidation and/or fluid injection.

[0139] FIG. 117 depicts an embodiment of treating a subsurface formation using a cylindrical pattern.

[0140] FIG. 118 depicts an embodiment of treating multiple portions of a subsurface formation in a rectangular pattern.

[0141] FIG. 119 is a schematic top view of the pattern depicted in FIG. 118.

[0142] FIG. 120 depicts a cross-sectional representation of an embodiment of substantially horizontal heaters positioned in a pattern with consistent spacing in a hydrocarbon layer.

[0143] FIG. 121 depicts a cross-sectional representation of an embodiment of substantially horizontal heaters positioned in a pattern with irregular spacing in a hydrocarbon layer.

[0144] FIG. 122 depicts a graphical representation of a comparison of the temperature and the pressure over time for two different portions of the formation using the different heating patterns.

[0145] FIG. 123 depicts a graphical representation of a comparison of the average temperature over time for different treatment areas for two different portions of the formation using the different heating patterns.

[0146] FIG. 124 depicts a graphical representation of the bottom-hole pressures for several producer wells for two different heating patterns.

[0147] FIG. 125 depicts a graphical representation of a comparison of the cumulative oil and gas products extracted over time from two different portions of the formation using the different heating patterns.

[0148] FIG. 126 depicts a cross-sectional representation of another embodiment of substantially horizontal heaters positioned in a pattern with irregular spacing in a hydrocarbon layer.

[0149] FIG. 127 depicts a cross-sectional representation of another embodiment of substantially horizontal heaters positioned in a pattern with irregular spacing in a hydrocarbon layer.

[0150] FIG. 128 depicts a cross-sectional representation of another additional embodiment of substantially horizontal heaters positioned in a pattern with irregular spacing in a hydrocarbon layer.

[0151] FIG. 129 depicts a cross-sectional representation of another embodiment of substantially horizontal heaters positioned in a pattern with consistent spacing in a hydrocarbon layer.

[0152] FIG. 130 depicts a cross-sectional representation of an embodiment of substantially horizontal heaters positioned in a pattern with irregular spacing in a hydrocarbon layer, with three rows of heaters in three heating zones.

[0153] FIG. 131 depicts a schematic representation of an embodiment of a system for producing oxygen for use in downhole oxidizer assemblies.

[0154] FIG. 132 depicts an embodiment of a heater with a heating section located in a u-shaped wellbore to create a first heated volume.

[0155] FIG. 133 depicts an embodiment of a heater with a heating section located in a u-shaped wellbore to create a second heated volume.

[0156] FIG. 134 depicts an embodiment of a heater with a heating section located in a u-shaped wellbore to create a third heated volume.

[0157] FIG. 135 depicts an embodiment of a heater with a heating section located in an L-shaped or J-shaped wellbore to create a first heated volume.

[0158] FIG. 136 depicts an embodiment of a heater with a heating section located in an L-shaped or J-shaped wellbore to create a second heated volume.

[0159] FIG. 137 depicts an embodiment of a heater with a heating section located in an L-shaped or J-shaped wellbore to create a third heated volume.

[0160] FIG. 138 depicts an embodiment of two heaters with heating sections located in a u-shaped wellbore to create two heated volumes.

[0161] FIG. 139 depicts a top view of a treatment area treated using non-overlapping heating sections in heaters.

[0162] FIG. 140 depicts a top view of a treatment area treated using overlapping heating sections in the first phase of heating using heaters.

[0163] FIG. 141 depicts a schematic representation of an embodiment of a heat transfer fluid circulation system for heating a portion of a formation.

[0164] FIG. 142 depicts a schematic representation of an embodiment of an L-shaped heater for use with a heat transfer fluid circulation system for heating a portion of a formation.

[0165] FIG. 143 depicts a schematic representation of an embodiment of a vertical heater for use with a heat transfer

fluid circulation system for heating a portion of a formation where thermal expansion of the heater is accommodated below the surface.

[0166] FIG. 144 depicts a schematic representation of another embodiment of a vertical heater for use with a heat transfer fluid circulation system for heating a portion of a formation where thermal expansion of the heater is accommodated above and below the surface.

[0167] FIG. 145 depicts a schematic representation of a corridor pattern system used to treat a treatment area.

[0168] FIG. 146 depicts a schematic representation of a radial pattern system used to treat a treatment area.

[0169] FIG. 147 depicts a plan view of an embodiment of wellbore openings on a first side of a treatment area.

[0170] FIG. 148 depicts a cross-sectional view of an embodiment of overburden insulation that utilizes insulating cement.

[0171] FIG. 149 depicts a cross-sectional view of an embodiment of overburden insulation that utilizes an insulating sleeve.

[0172] FIG. 150 depicts a cross-sectional view of an embodiment of overburden insulation that utilizes an insulating sleeve and a vacuum.

[0173] FIG. 151 depicts a representation an embodiment of bellows used to accommodate thermal expansion.

[0174] FIG. 152A depicts a representation of an embodiment of piping with an expansion loop for accommodating thermal expansion.

[0175] FIG. 152B depicts a representation of an embodiment of piping with coiled or spooled piping for accommodating thermal expansion.

[0176] FIG. 152C depicts a representation of an embodiment of piping with coiled or spooled piping for accommodating thermal expansion enclosed in an insulated volume.

[0177] FIG. 153 depicts a representation of an embodiment of insulated piping in a large diameter casing in the overburden.

[0178] FIG. 154 depicts a representation of an embodiment of insulated piping in a large diameter casing in the overburden to accommodate thermal expansion.

[0179] FIG. 155 depicts a representation of an embodiment of a wellhead with a sliding seal, stuffing box, or other pressure control equipment that allows a portion of a heater to move relative to the wellhead.

[0180] FIG. 156 depicts a representation of an embodiment of a wellhead with a slip joint that interacts with a fixed conduit above the wellhead.

[0181] FIG. 157 depicts a representation of an embodiment of a wellhead with a slip joint that interacts with a fixed conduit coupled to the wellhead.

[0182] FIG. 158 depicts a schematic representation of an embodiment a heat transfer fluid circulating system with seals.

[0183] FIG. 159 depicts a schematic representation of another embodiment a heat transfer fluid circulating system with seals.

[0184] FIG. 160 depicts a schematic representation an embodiment a heat transfer fluid circulating system with locking mechanisms and seals.

[0185] FIG. 161 depicts a representation of a u-shaped wellbore with a hot heat transfer fluid circulation system heater positioned in the wellbore.

[0186] FIG. 162 depicts a side view representation of an embodiment of a system for heating the formation that can use a closed loop circulation system and/or electrical heating.

[0187] FIG. 163 depicts a representation of a heat transfer fluid conduit that may initially be resistively heated with the return current path provided by an insulated conductor.

[0188] FIG. 164 depicts a representation of a heat transfer fluid conduit that may initially be resistively heated with the return current path provided by two insulated conductors.

[0189] FIG. 165 depicts a representation of insulated conductors used to resistively heat heaters of a circulated fluid heating system.

[0190] FIG. 166 depicts an end view representation of a heater of a heat transfer fluid circulation system with an insulated conductor heater positioned in the piping.

[0191] FIG. 167 depicts an end view representation of an embodiment of a conduit-in-conduit heater for a heat transfer circulation heating system adjacent to the treatment area.

[0192] FIG. 168 depicts a representation of an embodiment for heating various portions of a heater to restart flow of heat transfer fluid in the heater.

[0193] FIG. 169 depicts a schematic of an embodiment of conduit-in-conduit heaters of a fluid circulation heating system positioned in the formation.

[0194] FIG. 170 depicts a cross-sectional view of an embodiment of a conduit-in-conduit heater adjacent to the overburden.

[0195] FIG. 171 depicts a schematic representation of an embodiment of a circulation system for a liquid heat transfer fluid.

[0196] FIG. 172 depicts a schematic representation of an embodiment of a system for heating the formation using gas lift to return the heat transfer fluid to the surface.

[0197] FIG. 173 depicts an end view representation of an embodiment of a wellbore in a treatment area undergoing a combustion process.

[0198] FIG. 174 depicts an end view representation of an embodiment of a wellbore in a treatment area undergoing fluid removal following the combustion process.

[0199] FIG. 175 depicts an end view representation of an embodiment of a wellbore in a treatment area undergoing a combustion process using circulated molten salt to recover energy from the treatment area.

[0200] FIG. 176 depicts percentage of the expected coke distribution relative to a distance from a wellbore.

[0201] FIG. 177 depicts a schematic representation of an embodiment of an in situ heat treatment system that uses a nuclear reactor.

[0202] FIG. 178 depicts an elevational view of an embodiment of an in situ heat treatment system using pebble bed reactors.

[0203] FIG. 179 depicts a schematic representation of an embodiment of a self-regulating nuclear reactor.

[0204] FIG. 180 depicts a schematic representation of an embodiment of an in situ heat treatment system with u-shaped wellbores using self-regulating nuclear reactors.

[0205] FIG. 181 depicts a side view representation of an embodiment for producing mobilized fluids from a hydrocarbon formation.

[0206] FIG. 182 depicts a side view representation of an embodiment for producing mobilized fluids from a hydrocarbon formation heated by residual heat.

[0207] FIG. 183 depicts an embodiment of a solution mining well.

- [0208] FIG. 184 depicts a representation of an embodiment of a portion of a solution mining well.
- [0209] FIG. 185 depicts a representation of another embodiment of a portion of a solution mining well.
- [0210] FIG. 186 depicts an elevational view of a well pattern for solution mining and/or an in situ heat treatment process.
- [0211] FIG. 187 depicts a representation of wells of an in situ heating treatment process for solution mining and producing hydrocarbons from a formation.
- [0212] FIG. 188 depicts an embodiment for solution mining a formation.
- [0213] FIG. 189 depicts an embodiment of a formation with nahcolite layers in the formation before solution mining nahcolite from the formation.
- [0214] FIG. 190 depicts the formation of FIG. 189 after the nahcolite has been solution mined.
- [0215] FIG. 191 depicts an embodiment of two injection wells interconnected by a zone that has been solution mined to remove nahcolite from the zone.
- [0216] FIG. 192 depicts a representation of an embodiment for treating a portion of a formation having a hydrocarbon containing formation between an upper nahcolite bed and a lower nahcolite bed.
- [0217] FIG. 193 depicts a representation of a portion of the formation that is orthogonal to the formation depicted in FIG. 192 and passes through one of the solution mining wells in the upper nahcolite bed.
- [0218] FIG. 194 depicts an embodiment for heating a formation with dawsonite in the formation.
- [0219] FIG. 195 depicts a representation of an embodiment for solution mining with a steam and electricity cogeneration facility.
- [0220] FIG. 196 depicts an embodiment of treating a hydrocarbon containing formation with a combustion front.
- [0221] FIG. 197 depicts a cross-sectional representation of an embodiment for treating a hydrocarbon containing formation with a combustion front.
- [0222] FIG. 198 depicts a schematic representation of an embodiment of a circulated fluid cooling system.
- [0223] FIG. 199 depicts a schematic of an embodiment for treating a subsurface formation using heat sources having electrically conductive material.
- [0224] FIG. 200 depicts a schematic of an embodiment for treating a subsurface formation using a ground and heat sources having electrically conductive material.
- [0225] FIG. 201 depicts a schematic of an embodiment for treating a subsurface formation using heat sources having electrically conductive material and an electrical insulator.
- [0226] FIG. 202 depicts a schematic of an embodiment for treating a subsurface formation using electrically conductive heat sources extending from a common wellbore.
- [0227] FIG. 203 depicts a schematic of an embodiment for treating a subsurface formation having a shale layer using heat sources having electrically conductive material.
- [0228] FIG. 204A depicts a schematic of an embodiment of an electrode with a coated end.
- [0229] FIG. 204B depicts a schematic of an embodiment of an uncoated electrode.
- [0230] FIG. 205A depicts a schematic of another embodiment of a coated electrode.
- [0231] FIG. 205B depicts a schematic of another embodiment of an uncoated electrode.
- [0232] FIG. 206 depicts a perspective view of an embodiment of an underground treatment system.
- [0233] FIG. 207 depicts an exploded perspective view of an embodiment of a portion of an underground treatment system and tunnels.
- [0234] FIG. 208 depicts another exploded perspective view of an embodiment of a portion of an underground treatment system and tunnels.
- [0235] FIG. 209 depicts a side view representation of an embodiment for flowing heated fluid through heat sources between tunnels.
- [0236] FIG. 210 depicts a top view representation of an embodiment for flowing heated fluid through heat sources between tunnels.
- [0237] FIG. 211 depicts a perspective view of an embodiment of an underground treatment system having heater wellbores spanning between tunnels of the underground treatment system.
- [0238] FIG. 212 depicts a top view of an embodiment of tunnels with wellbore chambers.
- [0239] FIG. 213 depicts a top view of an embodiment of development of a tunnel.
- [0240] FIG. 214 depicts a schematic of an embodiment of an underground treatment system with surface production.
- [0241] FIG. 215 depicts a side view of an embodiment of an underground treatment system.
- [0242] FIG. 216 depicts a temperature profile in the formation after 360 days using the STARS simulation.
- [0243] FIG. 217 depicts an oil saturation profile in the formation after 360 days using the STARS simulation.
- [0244] FIG. 218 depicts the oil saturation profile in the formation after 1095 days using the STARS simulation.
- [0245] FIG. 219 depicts the oil saturation profile in the formation after 1470 days using the STARS simulation.
- [0246] FIG. 220 depicts the oil saturation profile in the formation after 1826 days using the STARS simulation.
- [0247] FIG. 221 depicts the temperature profile in the formation after 1826 days using the STARS simulation.
- [0248] FIG. 222 depicts oil production rate and gas production rate versus time.
- [0249] FIG. 223 depicts weight percentage of original bitumen in place (OBIP)(left axis) and volume percentage of OBIP (right axis) versus temperature ($^{\circ}$ C.).
- [0250] FIG. 224 depicts bitumen conversion percentage (weight percentage of (OBIP))(left axis) and oil, gas, and coke weight percentage (as a weight percentage of OBIP) (right axis) versus temperature ($^{\circ}$ C.).
- [0251] FIG. 225 depicts API gravity($^{\circ}$)(left axis) of produced fluids, blow down production, and oil left in place along with pressure (psig)(right axis) versus temperature ($^{\circ}$ C.).
- [0252] FIGS. 226A-D depict gas-to-oil ratios (GOR) in thousand cubic feet per barrel ((Mcf/bbl)(y-axis)) versus temperature ($^{\circ}$ C.)(x-axis) for different types of gas at a low temperature blow down (about 277° C.) and a high temperature blow down (at about 290° C.).
- [0253] FIG. 227 depicts coke yield (weight percentage)(y-axis) versus temperature ($^{\circ}$ C.)(x-axis).
- [0254] FIGS. 228A-D depict assessed hydrocarbon isomer shifts in fluids produced from the experimental cells as a function of temperature and bitumen conversion.
- [0255] FIG. 229 depicts weight percentage (Wt %)(y-axis) of saturates from SARA analysis of the produced fluids versus temperature ($^{\circ}$ C.)(x-axis).

[0256] FIG. 230 depicts weight percentage (Wt %)(y-axis) of n-C₇ of the produced fluids versus temperature (° C.)(x-axis).

[0257] FIG. 231 depicts oil recovery (volume percentage bitumen in place (vol % BIP)) versus API gravity(° as determined by the pressure (MPa) in the formation in an experiment.

[0258] FIG. 232 depicts recovery efficiency (%) versus temperature (° C.) at different pressures in an experiment.

[0259] FIG. 233 depicts average formation temperature (° C.) versus days for heating a formation using molten salt circulated through conduit-in-conduit heaters.

[0260] FIG. 234 depicts molten salt temperature (° C.) and power injection rate (W/ft) versus time (days).

[0261] FIG. 235 depicts temperature (° C.) and power injection rate (W/ft) versus time (days) for heating a formation using molten salt circulated through heaters with a heating length of 8000 ft at a mass flow rate of 18 kg/s.

[0262] FIG. 236 depicts temperature (° C.) and power injection rate (W/ft) versus time (days) for heating a formation using molten salt circulated through heaters with a heating length of 8000 ft at a mass flow rate of 12 kg/s.

[0263] FIG. 237 depicts power (W/ft)(y-axis) versus time (yr)(x-axis) of in situ heat treatment power injection requirements.

[0264] FIG. 238 depicts power (W/ft)(y-axis) versus time (days)(x-axis) of in situ heat treatment power injection requirements for different spacings between wellbores.

[0265] FIG. 239 depicts reservoir average temperature (° C.)(y-axis) versus time (days)(x-axis) of in situ heat treatment for different spacings between wellbores.

[0266] FIG. 240 depicts time (hour) versus temperature (° C.) and molten salt concentration in weight percent.

[0267] FIG. 241 depicts heat transfer rates versus time.

[0268] FIG. 242 depicts percentage of degree of saturation (volume water/air voids) versus time during immersion at a water temperature of 60° C.

[0269] FIG. 243 depicts retained indirect tensile strength stiffness modulus versus time during immersion at a water temperature of 60° C.

[0270] While the invention is susceptible to various modifications and alternative forms, specific embodiments thereof are shown by way of example in the drawings and may herein be described in detail. The drawings may not be to scale. It should be understood, however, that the drawings and detailed description thereto are not intended to limit the invention to the particular form disclosed, but on the contrary, the intention is to cover all modifications, equivalents and alternatives falling within the spirit and scope of the present invention as defined by the appended claims.

DETAILED DESCRIPTION

[0271] The following description generally relates to systems and methods for treating hydrocarbons in the formations. Such formations may be treated to yield hydrocarbon products, hydrogen, and other products.

[0272] “Alternating current (AC)” refers to a time-varying current that reverses direction substantially sinusoidally. AC produces skin effect electricity flow in a ferromagnetic conductor.

[0273] “Annular region” is the region between an outer conduit and an inner conduit positioned in the outer conduit.

[0274] “API gravity” refers to API gravity at 15.5° C. (60° F.). API gravity is as determined by ASTM Method D6822 or ASTM Method D1298.

[0275] “ASTM” refers to American Standard Testing and Materials.

[0276] In the context of reduced heat output heating systems, apparatus, and methods, the term “automatically” means such systems, apparatus, and methods function in a certain way without the use of external control (for example, external controllers such as a controller with a temperature sensor and a feedback loop, PID controller, or predictive controller).

[0277] “Asphalt/bitumen” refers to a semi-solid, viscous material soluble in carbon disulfide. Asphalt/bitumen may be obtained from refining operations or produced from subsurface formations.

[0278] “Bare metal” and “exposed metal” refer to metals of elongated members that do not include a layer of electrical insulation, such as mineral insulation, that is designed to provide electrical insulation for the metal throughout an operating temperature range of the elongated member. Bare metal and exposed metal may encompass a metal that includes a corrosion inhibitor such as a naturally occurring oxidation layer, an applied oxidation layer, and/or a film. Bare metal and exposed metal include metals with polymeric or other types of electrical insulation that cannot retain electrical insulating properties at typical operating temperature of the elongated member. Such material may be placed on the metal and may be thermally degraded during use of the heater.

[0279] Boiling range distributions for the formation fluid and liquid streams described herein are as determined by ASTM Method D5307 or ASTM Method D2887. Content of hydrocarbon components in weight percent for paraffins, isoparaffins, olefins, naphthenes and aromatics in the liquid streams is as determined by ASTM Method D6730. Content of aromatics in volume percent is as determined by ASTM Method D1319. Weight percent of hydrogen in hydrocarbons is as determined by ASTM Method D3343.

[0280] “Bromine number” refers to a weight percentage of olefins in grams per 100 gram of portion of the produced fluid that has a boiling range below 246° C. and testing the portion using ASTM Method D1159.

[0281] “Carbon number” refers to the number of carbon atoms in a molecule. A hydrocarbon fluid may include various hydrocarbons with different carbon numbers. The hydrocarbon fluid may be described by a carbon number distribution. Carbon numbers and/or carbon number distributions may be determined by true boiling point distribution and/or gas-liquid chromatography.

[0282] “Chemically stability” refers to the ability of a formation fluid to be transported without components in the formation fluid reacting to form polymers and/or compositions that plug pipelines, valves, and/or vessels.

[0283] “Clogging” refers to impeding and/or inhibiting flow of one or more compositions through a process vessel or a conduit.

[0284] “Column X element” or “Column X elements” refer to one or more elements of Column X of the Periodic Table, and/or one or more compounds of one or more elements of Column X of the Periodic Table, in which X corresponds to a column number (for example, 13-18) of the Periodic Table. For example, “Column 15 elements” refer to elements from Column 15 of the Periodic Table and/or compounds of one or more elements from Column 15 of the Periodic Table.

[0285] “Column X metal” or “Column X metals” refer to one or more metals of Column X of the Periodic Table and/or one or more compounds of one or more metals of Column X of the Periodic Table, in which X corresponds to a column number (for example, 1-12) of the Periodic Table. For example, “Column 6 metals” refer to metals from Column 6 of the Periodic Table and/or compounds of one or more metals from Column 6 of the Periodic Table.

[0286] “Condensable hydrocarbons” are hydrocarbons that condense at 25° C. and one atmosphere absolute pressure. Condensable hydrocarbons may include a mixture of hydrocarbons having carbon numbers greater than 4. “Non-condensable hydrocarbons” are hydrocarbons that do not condense at 25° C. and one atmosphere absolute pressure. Non-condensable hydrocarbons may include hydrocarbons having carbon numbers less than 5.

[0287] “Coring” is a process that generally includes drilling a hole into a formation and removing a substantially solid mass of the formation from the hole.

[0288] “Cracking” refers to a process involving decomposition and molecular recombination of organic compounds to produce a greater number of molecules than were initially present. In cracking, a series of reactions take place accompanied by a transfer of hydrogen atoms between molecules. For example, naphtha may undergo a thermal cracking reaction to form ethene and H₂.

[0289] “Curie temperature” is the temperature above which a ferromagnetic material loses all of its ferromagnetic properties. In addition to losing all of its ferromagnetic properties above the Curie temperature, the ferromagnetic material begins to lose its ferromagnetic properties when an increasing electrical current is passed through the ferromagnetic material.

[0290] “Diad” refers to a group of two items (for example, heaters, wellbores, or other objects) coupled together.

[0291] “Diesel” refers to hydrocarbons with a boiling range distribution between 260° C. and 343° C. (500-650° F.) at 0.101 MPa. Diesel content is determined by ASTM Method D2887.

[0292] “Enriched air” refers to air having a larger mole fraction of oxygen than air in the atmosphere. Air is typically enriched to increase combustion-supporting ability of the air.

[0293] A “fluid” may be, but is not limited to, a gas, a liquid, an emulsion, a slurry, and/or a stream of solid particles that has flow characteristics similar to liquid flow.

[0294] “Fluid injectivity” is the flow rate of fluids injected per unit of pressure differential between a first location and a second location.

[0295] “Fluid pressure” is a pressure generated by a fluid in a formation. “Lithostatic pressure” (sometimes referred to as “lithostatic stress”) is a pressure in a formation equal to a weight per unit area of an overlying rock mass. “Hydrostatic pressure” is a pressure in a formation exerted by a column of water.

[0296] A “formation” includes one or more hydrocarbon containing layers, one or more non-hydrocarbon layers, an overburden, and/or an underburden. “Hydrocarbon layers” refer to layers in the formation that contain hydrocarbons. The hydrocarbon layers may contain non-hydrocarbon material and hydrocarbon material. The “overburden” and/or the “underburden” include one or more different types of impermeable materials. For example, the overburden and/or underburden may include rock, shale, mudstone, or wet/tight carbonate. In some embodiments of in situ heat treatment

processes, the overburden and/or the underburden may include a hydrocarbon containing layer or hydrocarbon containing layers that are relatively impermeable and are not subjected to temperatures during in situ heat treatment processing that result in significant characteristic changes of the hydrocarbon containing layers of the overburden and/or the underburden. For example, the underburden may contain shale or mudstone, but the underburden is not allowed to heat to pyrolysis temperatures during the in situ heat treatment process. In some cases, the overburden and/or the underburden may be somewhat permeable.

[0297] “Formation fluids” refer to fluids present in a formation and may include pyrolyzation fluid, synthesis gas, mobilized hydrocarbons, and water (steam). Formation fluids may include hydrocarbon fluids as well as non-hydrocarbon fluids. The term “mobilized fluid” refers to fluids in a hydrocarbon containing formation that are able to flow as a result of thermal treatment of the formation. “Produced fluids” refer to fluids removed from the formation.

[0298] “Freezing point” of a hydrocarbon liquid refers to the temperature below which solid hydrocarbon crystals may form in the liquid. Freezing point is as determined by ASTM Method D5901.

[0299] “Heat flux” is a flow of energy per unit of area per unit of time (for example, Watts/meter²).

[0300] A “heat source” is any system for providing heat to at least a portion of a formation substantially by conductive and/or radiative heat transfer. For example, a heat source may include electrically conducting materials and/or electric heaters such as an insulated conductor, an elongated member, and/or a conductor disposed in a conduit. A heat source may also include systems that generate heat by burning a fuel external to or in a formation. The systems may be surface burners, downhole gas burners, flameless distributed combustors, and natural distributed combustors. In some embodiments, heat provided to or generated in one or more heat sources may be supplied by other sources of energy. The other sources of energy may directly heat a formation, or the energy may be applied to a transfer medium that directly or indirectly heats the formation. It is to be understood that one or more heat sources that are applying heat to a formation may use different sources of energy. Thus, for example, for a given formation some heat sources may supply heat from electrically conducting materials, electric resistance heaters, some heat sources may provide heat from combustion, and some heat sources may provide heat from one or more other energy sources (for example, chemical reactions, solar energy, wind energy, biomass, or other sources of renewable energy). A chemical reaction may include an exothermic reaction (for example, an oxidation reaction). A heat source may also include a electrically conducting material and/or a heater that provides heat to a zone proximate and/or surrounding a heating location such as a heater well.

[0301] A “heater” is any system or heat source for generating heat in a well or a near wellbore region. Heaters may be, but are not limited to, electric heaters, burners, combustors that react with material in or produced from a formation, and/or combinations thereof.

[0302] “Heavy hydrocarbons” are viscous hydrocarbon fluids. Heavy hydrocarbons may include highly viscous hydrocarbon fluids such as heavy oil, tar, and/or asphalt. Heavy hydrocarbons may include carbon and hydrogen, as well as smaller concentrations of sulfur, oxygen, and nitrogen. Additional elements may also be present in heavy hydro-

carbons in trace amounts. Heavy hydrocarbons may be classified by API gravity. Heavy hydrocarbons generally have an API gravity below about 20°. Heavy oil, for example, generally has an API gravity of about 10-20°, whereas tar generally has an API gravity below about 10°. The viscosity of heavy hydrocarbons is generally greater than about 100 centipoise at 15° C. Heavy hydrocarbons may include aromatics or other complex ring hydrocarbons.

[0303] Heavy hydrocarbons may be found in a relatively permeable formation. The relatively permeable formation may include heavy hydrocarbons entrained in, for example, sand or carbonate. "Relatively permeable" is defined, with respect to formations or portions thereof, as an average permeability of 10 millidarcy or more (for example, 10 or 100 millidarcy). "Relatively low permeability" is defined, with respect to formations or portions thereof, as an average permeability of less than about 10 millidarcy. One darcy is equal to about 0.99 square micrometers. An impermeable layer generally has a permeability of less than about 0.1 millidarcy.

[0304] Certain types of formations that include heavy hydrocarbons may also include, but are not limited to, natural mineral waxes, or natural asphaltites. "Natural mineral waxes" typically occur in substantially tubular veins that may be several meters wide, several kilometers long, and hundreds of meters deep. "Natural asphaltites" include solid hydrocarbons of an aromatic composition and typically occur in large veins. In situ recovery of hydrocarbons from formations such as natural mineral waxes and natural asphaltites may include melting to form liquid hydrocarbons and/or solution mining of hydrocarbons from the formations.

[0305] "Hydrocarbons" are generally defined as molecules formed primarily by carbon and hydrogen atoms. Hydrocarbons may also include other elements such as, but not limited to, halogens, metallic elements, nitrogen, oxygen, and/or sulfur. Hydrocarbons may be, but are not limited to, kerogen, bitumen, pyrobitumen, oils, natural mineral waxes, and asphaltites. Hydrocarbons may be located in or adjacent to mineral matrices in the earth. Matrices may include, but are not limited to, sedimentary rock, sands, silicilytes, carbonates, diatomites, and other porous media. "Hydrocarbon fluids" are fluids that include hydrocarbons. Hydrocarbon fluids may include, entrain, or be entrained in non-hydrocarbon fluids such as hydrogen, nitrogen, carbon monoxide, carbon dioxide, hydrogen sulfide, water, and ammonia.

[0306] An "in situ conversion process" refers to a process of heating a hydrocarbon containing formation from heat sources to raise the temperature of at least a portion of the formation above a pyrolysis temperature so that pyrolyzation fluid is produced in the formation.

[0307] An "in situ heat treatment process" refers to a process of heating a hydrocarbon containing formation with heat sources to raise the temperature of at least a portion of the formation above a temperature that results in mobilized fluid, visbreaking, and/or pyrolysis of hydrocarbon containing material so that mobilized fluids, visbroken fluids, and/or pyrolyzation fluids are produced in the formation.

[0308] "Insulated conductor" refers to any elongated material that is able to conduct electricity and that is covered, in whole or in part, by an electrically insulating material.

[0309] "Karst" is a subsurface shaped by the dissolution of a soluble layer or layers of bedrock, usually carbonate rock such as limestone or dolomite. The dissolution may be caused

by meteoric or acidic water. The Grosmont formation in Alberta, Canada is an example of a karst (or "karsted") carbonate formation.

[0310] "Kerogen" is a solid, insoluble hydrocarbon that has been converted by natural degradation and that principally contains carbon, hydrogen, nitrogen, oxygen, and sulfur. Coal and oil shale are typical examples of materials that contain kerogen. "Bitumen" is a non-crystalline solid or viscous hydrocarbon material that is substantially soluble in carbon disulfide. "Oil" is a fluid containing a mixture of condensable hydrocarbons.

[0311] "Kerosene" refers to hydrocarbons with a boiling range distribution between 204° C. and 260° C. at 0.101 MPa. Kerosene content is determined by ASTM Method D2887.

[0312] "Modulated direct current (DC)" refers to any substantially non-sinusoidal time-varying current that produces skin effect electricity flow in a ferromagnetic conductor.

[0313] "Naphtha" refers to hydrocarbon components with a boiling range distribution between 38° C. and 200° C. at 0.101 MPa. Naphtha content is determined by ASTM Method D5307.

[0314] "Nitride" refers to a compound of nitrogen and one or more other elements of the Periodic Table. Nitrides include, but are not limited to, silicon nitride, boron nitride, or alumina nitride.

[0315] "Nitrogen compound content" refers to an amount of nitrogen in an organic compound. Nitrogen content is as determined by ASTM Method D5762.

[0316] "Octane Number" refers to a calculated numerical representation of the antiknock properties of a motor fuel compared to a standard reference fuel. A calculated octane number is determined by ASTM Method D6730.

[0317] "Olefins" are molecules that include unsaturated hydrocarbons having one or more non-aromatic carbon-carbon double bonds.

[0318] "Olefin content" refers to an amount of non-aromatic olefins in a fluid. Olefin content for a produced fluid is determined by obtaining a portion of the produce fluid that has a boiling point of 246° C. and testing the portion using ASTM Method D1159 and reporting the result as a bromine factor in grams per 100 gram of portion. Olefin content is also determined by the Canadian Association of Petroleum Producers (CAPP) olefin method and is reported in percent olefin as 1-decene equivalent.

[0319] "Organonitrogen compounds" refer to hydrocarbons that contain at least one nitrogen atom. Non-limiting examples of organonitrogen compounds include, but are not limited to, alkyl amines, aromatic amines, alkyl amides, aromatic amides, pyridines, pyrazoles, and oxazoles.

[0320] "Orifices" refer to openings, such as openings in conduits, having a wide variety of sizes and cross-sectional shapes including, but not limited to, circles, ovals, squares, rectangles, triangles, slits, or other regular or irregular shapes.

[0321] "P (peptization) value" or "P-value" refers to a numerical value, which represents the flocculation tendency of asphaltenes in a formation fluid. P-value is determined by ASTM method D7060.

[0322] "Perforations" include openings, slits, apertures, or holes in a wall of a conduit, tubular, pipe or other flow pathway that allow flow into or out of the conduit, tubular, pipe or other flow pathway.

[0323] "Periodic Table" refers to the Periodic Table as specified by the International Union of Pure and Applied Chemistry (IUPAC), November 2003. In the scope of this

application, weight of a metal from the Periodic Table, weight of a compound of a metal from the Periodic Table, weight of an element from the Periodic Table, or weight of a compound of an element from the Periodic Table is calculated as the weight of metal or the weight of element. For example, if 0.1 grams of MoO₃ is used per gram of catalyst, the calculated weight of the molybdenum metal in the catalyst is 0.067 grams per gram of catalyst.

[0324] “Phase transformation temperature” of a ferromagnetic material refers to a temperature or a temperature range during which the material undergoes a phase change (for example, from ferrite to austenite) that decreases the magnetic permeability of the ferromagnetic material. The reduction in magnetic permeability is similar to reduction in magnetic permeability due to the magnetic transition of the ferromagnetic material at the Curie temperature.

[0325] “Physical stability” refers to the ability of a formation fluid to not exhibit phase separation or flocculation during transportation of the fluid. Physical stability is determined by ASTM Method D7060.

[0326] “Pyrolysis” is the breaking of chemical bonds due to the application of heat. For example, pyrolysis may include transforming a compound into one or more other substances by heat alone. Heat may be transferred to a section of the formation to cause pyrolysis.

[0327] “Pyrolyzation fluids” or “pyrolysis products” refers to fluid produced substantially during pyrolysis of hydrocarbons. Fluid produced by pyrolysis reactions may mix with other fluids in a formation. The mixture would be considered pyrolyzation fluid or pyrolyzation product. As used herein, “pyrolysis zone” refers to a volume of a formation (for example, a relatively permeable formation such as a tar sands formation) that is reacted or reacting to form a pyrolyzation fluid.

[0328] “Residue” refers to hydrocarbons that have a boiling point above 537° C. (1000° F.).

[0329] “Rich layers” in a hydrocarbon containing formation are relatively thin layers (typically about 0.2 m to about 0.5 m thick). Rich layers generally have a richness of about 0.150 L/kg or greater. Some rich layers have a richness of about 0.170 L/kg or greater, of about 0.190 L/kg or greater, or of about 0.210 L/kg or greater. Lean layers of the formation have a richness of about 0.100 L/kg or less and are generally thicker than rich layers. The richness and locations of layers are determined, for example, by coring and subsequent Fischer assay of the core, density or neutron logging, or other logging methods. Rich layers may have a lower initial thermal conductivity than other layers of the formation. Typically, rich layers have a thermal conductivity 1.5 times to 3 times lower than the thermal conductivity of lean layers. In addition, rich layers have a higher thermal expansion coefficient than lean layers of the formation.

[0330] “Smart well technology” or “smart wellbore” refers to wells that incorporate downhole measurement and/or control. For injection wells, smart well technology may allow for controlled injection of fluid into the formation in desired zones. For production wells, smart well technology may allow for controlled production of formation fluid from selected zones. Some wells may include smart well technology that allows for formation fluid production from selected zones and simultaneous or staggered solution injection into other zones. Smart well technology may include fiber optic systems and control valves in the wellbore. A smart wellbore used for an in situ heat treatment process may be Westbay

Multilevel Well System MP55 available from Westbay Instruments Inc. (Burnaby, British Columbia, Canada).

[0331] “Subsidence” is a downward movement of a portion of a formation relative to an initial elevation of the surface.

[0332] “Sulfur compound content” refers to an amount of sulfur in an organic compound. Sulfur content is as determined by ASTM Method D4294.

[0333] “Superposition of heat” refers to providing heat from two or more heat sources to a selected section of a formation such that the temperature of the formation at least at one location between the heat sources is influenced by the heat sources.

[0334] “Synthesis gas” is a mixture including hydrogen and carbon monoxide. Additional components of synthesis gas may include water, carbon dioxide, nitrogen, methane, and other gases. Synthesis gas may be generated by a variety of processes and feedstocks. Synthesis gas may be used for synthesizing a wide range of compounds.

[0335] “TAN” refers to a total acid number expressed as milligrams (“mg”) of KOH per gram (“g”) of sample. TAN is as determined by ASTM Method D3242.

[0336] “Tar” is a viscous hydrocarbon that generally has a viscosity greater than about 10,000 centipoise at 15° C. The specific gravity of tar generally is greater than 1.000. Tar may have an API gravity less than 10°.

[0337] A “tar sands formation” is a formation in which hydrocarbons are predominantly present in the form of heavy hydrocarbons and/or tar entrained in a mineral grain framework or other host lithology (for example, sand or carbonate). Examples of tar sands formations include formations such as the Athabasca formation, the Grosmont formation, and the Peace River formation, all three in Alberta, Canada; and the Faja formation in the Orinoco belt in Venezuela.

[0338] “Temperature limited heater” generally refers to a heater that regulates heat output (for example, reduces heat output) above a specified temperature without the use of external controls such as temperature controllers, power regulators, rectifiers, or other devices. Temperature limited heaters may be AC (alternating current) or modulated (for example, “chopped”) DC (direct current) powered electrical resistance heaters.

[0339] “Thermally conductive fluid” includes fluid that has a higher thermal conductivity than air at standard temperature and pressure (STP) (0° C. and 101.325 kPa).

[0340] “Thermal conductivity” is a property of a material that describes the rate at which heat flows, in steady state, between two surfaces of the material for a given temperature difference between the two surfaces.

[0341] “Thermal fracture” refers to fractures created in a formation caused by expansion or contraction of a formation and/or fluids in the formation, which is in turn caused by increasing/decreasing the temperature of the formation and/or fluids in the formation, and/or by increasing/decreasing a pressure of fluids in the formation due to heating.

[0342] “Thermal oxidation stability” refers to thermal oxidation stability of a liquid. Thermal oxidation stability is as determined by ASTM Method D3241.

[0343] “Thickness” of a layer refers to the thickness of a cross section of the layer, wherein the cross section is normal to a face of the layer.

[0344] “Time-varying current” refers to electrical current that produces skin effect electricity flow in a ferromagnetic conductor and has a magnitude that varies with time. Time-

varying current includes both alternating current (AC) and modulated direct current (DC).

[0345] “Triad” refers to a group of three items (for example, heaters, wellbores, or other objects) coupled together.

[0346] “Turndown ratio” for the temperature limited heater in which current is applied directly to the heater is the ratio of the highest AC or modulated DC resistance below the Curie temperature to the lowest resistance above the Curie temperature for a given current. Turndown ratio for an inductive heater is the ratio of the highest heat output below the Curie temperature to the lowest heat output above the Curie temperature for a given current applied to the heater.

[0347] A “u-shaped wellbore” refers to a wellbore that extends from a first opening in the formation, through at least a portion of the formation, and out through a second opening in the formation. In this context, the wellbore may be only roughly in the shape of a “v” or “u”, with the understanding that the “legs” of the “u” do not need to be parallel to each other, or perpendicular to the “bottom” of the “u” for the wellbore to be considered “u-shaped”.

[0348] “Upgrade” refers to increasing the quality of hydrocarbons. For example, upgrading heavy hydrocarbons may result in an increase in the API gravity of the heavy hydrocarbons.

[0349] “Visbreaking” refers to the untangling of molecules in fluid during heat treatment and/or to the breaking of large molecules into smaller molecules during heat treatment, which results in a reduction of the viscosity of the fluid.

[0350] “Viscosity” refers to kinematic viscosity at 40° C. unless otherwise specified. Viscosity is as determined by ASTM Method D445.

[0351] “VGO” or “vacuum gas oil” refers to hydrocarbons with a boiling range distribution between 343° C. and 538° C. at 0.101 MPa. VGO content is determined by ASTM Method D5307.

[0352] A “vug” is a cavity, void or large pore in a rock that is commonly lined with mineral precipitates.

[0353] “Wax” refers to a low melting organic mixture, or a compound of high molecular weight that is a solid at lower temperatures and a liquid at higher temperatures, and when in solid form can form a barrier to water. Examples of waxes include animal waxes, vegetable waxes, mineral waxes, petroleum waxes, and synthetic waxes.

[0354] The term “wellbore” refers to a hole in a formation made by drilling or insertion of a conduit into the formation. A wellbore may have a substantially circular cross section, or another cross-sectional shape. As used herein, the terms “well” and “opening,” when referring to an opening in the formation may be used interchangeably with the term “wellbore.”

[0355] A formation may be treated in various ways to produce many different products. Different stages or processes may be used to treat the formation during an in situ heat treatment process. In some embodiments, one or more sections of the formation are solution mined to remove soluble minerals from the sections. Solution mining minerals may be performed before, during, and/or after the in situ heat treatment process. In some embodiments, the average temperature of one or more sections being solution mined may be maintained below about 120° C.

[0356] In some embodiments, one or more sections of the formation are heated to remove water from the sections and/or to remove methane and other volatile hydrocarbons from the sections. In some embodiments, the average temperature

may be raised from ambient temperature to temperatures below about 220° C. during removal of water and volatile hydrocarbons.

[0357] In some embodiments, one or more sections of the formation are heated to temperatures that allow for movement and/or visbreaking of hydrocarbons in the formation. In some embodiments, the average temperature of one or more sections of the formation are raised to mobilization temperatures of hydrocarbons in the sections (for example, to temperatures ranging from 100° C. to 250° C., from 120° C. to 240° C., or from 150° C. to 230° C.).

[0358] In some embodiments, one or more sections are heated to temperatures that allow for pyrolysis reactions in the formation. In some embodiments, the average temperature of one or more sections of the formation may be raised to pyrolysis temperatures of hydrocarbons in the sections (for example, temperatures ranging from 230° C. to 900° C., from 240° C. to 400° C. or from 250° C. to 350° C.).

[0359] Heating the hydrocarbon containing formation with a plurality of heat sources may establish thermal gradients around the heat sources that raise the temperature of hydrocarbons in the formation to desired temperatures at desired heating rates. The rate of temperature increase through mobilization temperature range and/or pyrolysis temperature range for desired products may affect the quality and quantity of the formation fluids produced from the hydrocarbon containing formation. Slowly raising the temperature of the formation through the mobilization temperature range and/or pyrolysis temperature range may allow for the production of high quality, high API gravity hydrocarbons from the formation. Slowly raising the temperature of the formation through the mobilization temperature range and/or pyrolysis temperature range may allow for the removal of a large amount of the hydrocarbons present in the formation as hydrocarbon product.

[0360] In some in situ heat treatment embodiments, a portion of the formation is heated to a desired temperature instead of slowly heating the temperature through a temperature range. In some embodiments, the desired temperature is 300° C., 325° C., or 350° C. Other temperatures may be selected as the desired temperature.

[0361] Superposition of heat from heat sources allows the desired temperature to be relatively quickly and efficiently established in the formation. Energy input into the formation from the heat sources may be adjusted to maintain the temperature in the formation substantially at a desired temperature.

[0362] Mobilization and/or pyrolysis products may be produced from the formation through production wells. In some embodiments, the average temperature of one or more sections is raised to mobilization temperatures and hydrocarbons are produced from the production wells. The average temperature of one or more of the sections may be raised to pyrolysis temperatures after production due to mobilization decreases below a selected value. In some embodiments, the average temperature of one or more sections may be raised to pyrolysis temperatures without significant production before reaching pyrolysis temperatures. Formation fluids including pyrolysis products may be produced through the production wells.

[0363] In some embodiments, the average temperature of one or more sections may be raised to temperatures sufficient to allow synthesis gas production after mobilization and/or pyrolysis. In some embodiments, hydrocarbons may be

raised to temperatures sufficient to allow synthesis gas production without significant production before reaching the temperatures sufficient to allow synthesis gas production. For example, synthesis gas may be produced in a temperature range from about 400° C. to about 1200° C., about 500° C. to about 1100° C., or about 550° C. to about 1000° C. A synthesis gas generating fluid (for example, steam and/or water) may be introduced into the sections to generate synthesis gas. Synthesis gas may be produced from production wells.

[0364] Solution mining, removal of volatile hydrocarbons and water, mobilizing hydrocarbons, pyrolyzing hydrocarbons, generating synthesis gas, and/or other processes may be performed during the in situ heat treatment process. In some embodiments, some processes may be performed after the in situ heat treatment process. Such processes may include, but are not limited to, recovering heat from treated sections, storing fluids (for example, water and/or hydrocarbons) in previously treated sections, and/or sequestering carbon dioxide in previously treated sections.

[0365] FIG. 1 depicts a schematic view of an embodiment of a portion of the in situ heat treatment system for treating the hydrocarbon containing formation. The in situ heat treatment system may include barrier wells 200. Barrier wells are used to form a barrier around a treatment area. The barrier inhibits fluid flow into and/or out of the treatment area. Barrier wells include, but are not limited to, dewatering wells, vacuum wells, capture wells, injection wells, grout wells, freeze wells, or combinations thereof. In some embodiments, barrier wells 200 are dewatering wells. Dewatering wells may remove liquid water and/or inhibit liquid water from entering a portion of the formation to be heated, or to the formation being heated. In the embodiment depicted in FIG. 1, the barrier wells 200 are shown extending only along one side of heat sources 202, but the barrier wells typically encircle all heat sources 202 used, or to be used, to heat a treatment area of the formation.

[0366] Heat sources 202 are placed in at least a portion of the formation. Heat sources 202 may include heaters such as insulated conductors, conductor-in-conduit heaters, surface burners, flameless distributed combustors, and/or natural distributed combustors. Heat sources 202 may also include other types of heaters. Heat sources 202 provide heat to at least a portion of the formation to heat hydrocarbons in the formation. Energy may be supplied to heat sources 202 through supply lines 204. Supply lines 204 may be structurally different depending on the type of heat source or heat sources used to heat the formation. Supply lines 204 for heat sources may transmit electricity for electric heaters, may transport fuel for combustors, or may transport heat exchange fluid that is circulated in the formation. In some embodiments, electricity for an in situ heat treatment process may be provided by a nuclear power plant or nuclear power plants. The use of nuclear power may allow for reduction or elimination of carbon dioxide emissions from the in situ heat treatment process.

[0367] When the formation is heated, the heat input into the formation may cause expansion of the formation and geomechanical motion. The heat sources may be turned on before, at the same time, or during a dewatering process. Computer simulations may model formation response to heating. The computer simulations may be used to develop a pattern and time sequence for activating heat sources in the formation so that geomechanical motion of the formation does not

adversely affect the functionality of heat sources, production wells, and other equipment in the formation.

[0368] Heating the formation may cause an increase in permeability and/or porosity of the formation. Increases in permeability and/or porosity may result from a reduction of mass in the formation due to vaporization and removal of water, removal of hydrocarbons, and/or creation of fractures. Fluid may flow more easily in the heated portion of the formation because of the increased permeability and/or porosity of the formation. Fluid in the heated portion of the formation may move a considerable distance through the formation because of the increased permeability and/or porosity. The considerable distance may be over 1000 m depending on various factors, such as permeability of the formation, properties of the fluid, temperature of the formation, and pressure gradient allowing movement of the fluid. The ability of fluid to travel considerable distance in the formation allows production wells 206 to be spaced relatively far apart in the formation.

[0369] Production wells 206 are used to remove formation fluid from the formation. In some embodiments, production well 206 includes a heat source. The heat source in the production well may heat one or more portions of the formation at or near the production well. In some in situ heat treatment process embodiments, the amount of heat supplied to the formation from the production well per meter of the production well is less than the amount of heat applied to the formation from a heat source that heats the formation per meter of the heat source. Heat applied to the formation from the production well may increase formation permeability adjacent to the production well by vaporizing and removing liquid phase fluid adjacent to the production well and/or by increasing the permeability of the formation adjacent to the production well by formation of macro and/or micro fractures.

[0370] More than one heat source may be positioned in the production well. A heat source in a lower portion of the production well may be turned off when superposition of heat from adjacent heat sources heats the formation sufficiently to counteract benefits provided by heating the formation with the production well. In some embodiments, the heat source in an upper portion of the production well may remain on after the heat source in the lower portion of the production well is deactivated. The heat source in the upper portion of the well may inhibit condensation and reflux of formation fluid.

[0371] In some embodiments, the heat source in production well 206 allows for vapor phase removal of formation fluids from the formation. Providing heating at or through the production well may: (1) inhibit condensation and/or refluxing of production fluid when such production fluid is moving in the production well proximate the overburden, (2) increase heat input into the formation, (3) increase production rate from the production well as compared to a production well without a heat source, (4) inhibit condensation of high carbon number compounds (C₆ hydrocarbons and above) in the production well, and/or (5) increase formation permeability at or proximate the production well.

[0372] Subsurface pressure in the formation may correspond to the fluid pressure generated in the formation. As temperatures in the heated portion of the formation increase, the pressure in the heated portion may increase as a result of thermal expansion of in situ fluids, increased fluid generation and vaporization of water. Controlling rate of fluid removal from the formation may allow for control of pressure in the formation. Pressure in the formation may be determined at a

number of different locations, such as near or at production wells, near or at heat sources, or at monitor wells.

[0373] In some hydrocarbon containing formations, production of hydrocarbons from the formation is inhibited until at least some hydrocarbons in the formation have been mobilized and/or pyrolyzed. Formation fluid may be produced from the formation when the formation fluid is of a selected quality. In some embodiments, the selected quality includes an API gravity of at least about 20°, 30°, or 40°. Inhibiting production until at least some hydrocarbons are mobilized and/or pyrolyzed may increase conversion of heavy hydrocarbons to light hydrocarbons. Inhibiting initial production may minimize the production of heavy hydrocarbons from the formation. Production of substantial amounts of heavy hydrocarbons may require expensive equipment and/or reduce the life of production equipment.

[0374] In some hydrocarbon containing formations, hydrocarbons in the formation may be heated to mobilization and/or pyrolysis temperatures before substantial permeability has been generated in the heated portion of the formation. An initial lack of permeability may inhibit the transport of generated fluids to production wells **206**. During initial heating, fluid pressure in the formation may increase proximate heat sources **202**. The increased fluid pressure may be released, monitored, altered, and/or controlled through one or more heat sources **202**. For example, selected heat sources **202** or separate pressure relief wells may include pressure relief valves that allow for removal of some fluid from the formation.

[0375] In some embodiments, pressure generated by expansion of mobilized fluids, pyrolysis fluids or other fluids generated in the formation may be allowed to increase although an open path to production wells **206** or any other pressure sink may not yet exist in the formation. The fluid pressure may be allowed to increase towards a lithostatic pressure. Fractures in the hydrocarbon containing formation may form when the fluid approaches the lithostatic pressure. For example, fractures may form from heat sources **202** to production wells **206** in the heated portion of the formation. The generation of fractures in the heated portion may relieve some of the pressure in the portion. Pressure in the formation may have to be maintained below a selected pressure to inhibit unwanted production, fracturing of the overburden or underburden, and/or coking of hydrocarbons in the formation.

[0376] After mobilization and/or pyrolysis temperatures are reached and production from the formation is allowed, pressure in the formation may be varied to alter and/or control a composition of formation fluid produced, to control a percentage of condensable fluid as compared to non-condensable fluid in the formation fluid, and/or to control an API gravity of formation fluid being produced. For example, decreasing pressure may result in production of a larger condensable fluid component. The condensable fluid component may contain a larger percentage of olefins.

[0377] In some in situ heat treatment process embodiments, pressure in the formation may be maintained high enough to promote production of formation fluid with an API gravity of greater than 20°. Maintaining increased pressure in the formation may inhibit formation subsidence during in situ heat treatment. Maintaining increased pressure may reduce or eliminate the need to compress formation fluids at the surface to transport the fluids in collection conduits to treatment facilities.

[0378] Maintaining increased pressure in a heated portion of the formation may surprisingly allow for production of large quantities of hydrocarbons of increased quality and of relatively low molecular weight. Pressure may be maintained so that formation fluid produced has a minimal amount of compounds above a selected carbon number. The selected carbon number may be at most 25, at most 20, at most 12, or at most 8. Some high carbon number compounds may be entrained in vapor in the formation and may be removed from the formation with the vapor. Maintaining increased pressure in the formation may inhibit entrainment of high carbon number compounds and/or multi-ring hydrocarbon compounds in the vapor. High carbon number compounds and/or multi-ring hydrocarbon compounds may remain in a liquid phase in the formation for significant time periods. The significant time periods may provide sufficient time for the compounds to pyrolyze to form lower carbon number compounds.

[0379] Generation of relatively low molecular weight hydrocarbons is believed to be due, in part, to autogenous generation and reaction of hydrogen in a portion of the hydrocarbon containing formation. For example, maintaining an increased pressure may force hydrogen generated during pyrolysis into the liquid phase within the formation. Heating the portion to a temperature in a pyrolysis temperature range may pyrolyze hydrocarbons in the formation to generate liquid phase pyrolyzation fluids. The generated liquid phase pyrolyzation fluids components may include double bonds and/or radicals. Hydrogen (H₂) in the liquid phase may reduce double bonds of the generated pyrolyzation fluids, thereby reducing a potential for polymerization or formation of long chain compounds from the generated pyrolyzation fluids. In addition, H₂ may also neutralize radicals in the generated pyrolyzation fluids. H₂ in the liquid phase may inhibit the generated pyrolyzation fluids from reacting with each other and/or with other compounds in the formation.

[0380] Formation fluid produced from production wells **206** may be transported through collection piping **208** to treatment facilities **210**. Formation fluids may also be produced from heat sources **202**. For example, fluid may be produced from heat sources **202** to control pressure in the formation adjacent to the heat sources. Fluid produced from heat sources **202** may be transported through tubing or piping to collection piping **208** or the produced fluid may be transported through tubing or piping directly to treatment facilities **210**. Treatment facilities **210** may include separation units, reaction units, upgrading units, fuel cells, turbines, storage vessels, and/or other systems and units for processing produced formation fluids. The treatment facilities may form transportation fuel from at least a portion of the hydrocarbons produced from the formation. In some embodiments, the transportation fuel may be jet fuel, such as JP-8.

[0381] Formation fluid may be hot when produced from the formation through the production wells. Hot formation fluid may be produced during solution mining processes and/or during in situ heat treatment processes. In some embodiments, electricity may be generated using the heat of the fluid produced from the formation. Also, heat recovered from the formation after the in situ process may be used to generate electricity. The generated electricity may be used to supply power to the in situ heat treatment process. For example, the electricity may be used to power heaters, or to power a refrigeration system for forming or maintaining a low temperature barrier. Electricity may be generated using a Kalina cycle,

Rankine cycle or other thermodynamic cycle. In some embodiments, the working fluid for the cycle used to generate electricity is aqua ammonia.

[0382] FIGS. 2 and 3 depict schematic representations of systems for producing crude products and/or commercial products from the in situ heat treatment process liquid stream and/or the in situ heat treatment process gas stream. As shown, formation fluid **212** enters fluid separation unit **214** and is separated into in situ heat treatment process liquid stream **216**, in situ heat treatment process gas **218** and aqueous stream **220**. In some embodiments, liquid stream **216** may be transported to other processing units and/or facilities.

[0383] In some embodiments, fluid separation unit **214** includes a quench zone. As produced formation fluid enters the quench zone, quenching fluid such as water, nonpotable water, hydrocarbon diluent, and/or other components may be added to the formation fluid to quench and/or cool the formation fluid to a temperature suitable for handling in downstream processing equipment. Quenching the formation fluid may inhibit formation of compounds that contribute to physical and/or chemical instability of the fluid (for example, inhibit formation of compounds that may precipitate from solution, contribute to corrosion, and/or fouling of downstream equipment and/or piping). The quenching fluid may be introduced into the formation fluid as a spray and/or a liquid stream. In some embodiments, the formation fluid is introduced into the quenching fluid. In some embodiments, the formation fluid is cooled by passing the fluid through a heat exchanger to remove some heat from the formation fluid. The quench fluid may be added to the cooled formation fluid when the temperature of the formation fluid is near or at the dew point of the quench fluid. Quenching the formation fluid near or at the dew point of the quench fluid may enhance solubilization of salts that may cause chemical and/or physical instability of the quenched fluid (for example, ammonium salts). In some embodiments, an amount of water used in the quench is minimal so that salts of inorganic compounds and/or other components do not separate from the mixture. In separation unit **214**, at least a portion of the quench fluid may be separated from the quench mixture and recycled to the quench zone with a minimal amount of treatment. Heat produced from the quench may be captured and used in other facilities. In some embodiments, vapor may be produced during the quench. The produced vapor may be sent to gas separation unit **222** and/or sent to other facilities for processing.

[0384] In situ heat treatment process gas **218** may enter gas separation unit **222** to separate gas hydrocarbon stream **224** from the in situ heat treatment process gas. Gas separation unit **222** may include a physical treatment system and/or a chemical treatment system. The physical treatment system may include, but is not limited to, a membrane unit, a pressure swing adsorption unit, a liquid absorption unit, and/or a cryogenic unit. The chemical treatment system may include units that use amines (for example, diethanolamine or di-isopropanolamine), zinc oxide, sulfolane, water, or mixtures thereof in the treatment process. In some embodiments, gas separation unit **222** uses a Sulfinol gas treatment process for removal of sulfur compounds. Carbon dioxide may be removed using Catacarb® (Catacarb, Overland Park, Kans., U.S.A.) and/or Benfield (UOP, Des Plaines, Ill., U.S.A.) gas treatment processes. In some embodiments, the gas separation unit is a rectified adsorption and high pressure fractionation unit. In some embodiments, in situ heat treatment process gas is

treated to remove at least 50%, at least 60%, at least 70%, at least 80% or at least 90% by volume of ammonia present in the gas stream.

[0385] In gas separation unit **222**, treatment of in situ heat conversion treatment gas **218** removes sulfur compounds, carbon dioxide, and/or hydrogen to produce gas hydrocarbon stream **224**. In some embodiments, in situ heat treatment process gas **218** includes about 20 vol % hydrogen, about 30% methane, about 12% carbon dioxide, about 14 vol % C₂ hydrocarbons, about 5 vol % hydrogen sulfide, about 10 vol % C₃ hydrocarbons, about 7 vol % C₄ hydrocarbons, about 2 vol % C₅ hydrocarbons, and mixtures thereof, with the balance being heavier hydrocarbons, water, ammonia, COS, thiols and thiophenes. Gas hydrocarbon stream **224** includes hydrocarbons having a carbon number of at least 3. In some embodiments, in situ treatment process gas **218** may be cryogenically treated as described in U.S. Published Patent Application No. 2009-0071652 to Vinegar et al. Cryogenic treatment of an in situ process gas may produce a gas stream acceptable for sale, transportation, and/or use as a fuel. It would be advantageous to separate in situ treatment process gas **218** at the treatment site to produce streams useable as energy sources to lower overall energy costs. For example, streams containing hydrocarbons and/or hydrogen may be used as fuel for burners and/or process equipment. Streams containing sulfur compounds may be used as fuel for burners. Streams containing one or more carbon oxides and/or hydrocarbons may be used to form barriers around a treatment site. Streams containing hydrocarbons having a carbon number of at most 2 may be provided to ammonia processing facilities and/or barrier well systems. In situ heat treatment process gas **218** may include a sufficient amount of hydrogen such that the freezing point of carbon dioxide is depressed. Depression of the freezing point of carbon dioxide may allow cryogenic separation of hydrogen and/or hydrocarbons from the carbon dioxide using distillation methods instead of removing the carbon dioxide by cryogenic precipitation methods. In some embodiments, the freezing point of carbon dioxide may be depressed by adjusting the concentration of molecular hydrogen and/or addition of heavy hydrocarbons to the process gas stream.

[0386] In some embodiments, the process gas stream may include microscopic/molecular species of mercury and/or compounds of mercury. The process gas stream may include dissolved, entrained or solid particulates of metallic mercury, ionic mercury, organometallic compounds of mercury (for example, alkyl mercury), or inorganic compounds of mercury (for example, mercury sulfide). The process gas stream may be processed through a membrane filtration system used for filtering liquid hydrocarbon stream **232** described herein and/or as described in International Application No. WO 2008/116864 to Den Boestert et al., which is incorporated herein by reference, to remove mercury or mercury compounds from the process gas stream described below. After filtration, the filtered process gas stream (permeate) may have a mercury content of 100 ppbw (parts per billion by weight) or less, 25 ppbw or less, 5 ppbw or less, 2 ppbw or less, or 1 ppbw or less.

[0387] In some embodiments, the desalting unit may produce a liquid hydrocarbon stream and a salty process liquid stream. In situ heat treatment process liquid stream **216** enters liquid separation unit **226**. Separation unit **226** may include one or more distillation units. In liquid separation unit **226**, separation of in situ heat treatment process liquid stream **216** produces gas hydrocarbon stream **228**, salty process liquid

stream 230, and liquid hydrocarbon stream 232. Gas hydrocarbon stream 228 may include hydrocarbons having a carbon number of at most 5. A portion of gas hydrocarbon stream 228 may be combined with gas hydrocarbon stream 224. Salty process liquid stream 230 may be processed as described in the discussion of FIG. 3. Salty process liquid stream 230 may include hydrocarbons having a boiling point above 260° C. In some embodiments and as depicted in FIG. 2, salty process liquid stream 230 enters desalting unit 234. In desalting unit 234, salty process liquid stream 230 may be treated to form liquid stream 236 using known desalting and water removal methods. Liquid stream 236 may enter separation unit 238. In separation unit 238, liquid stream 236 is separated into bottoms stream 240 and hydrocarbon stream 242. In some embodiments, hydrocarbon stream 242 may have a boiling range distribution between about 200° C. and about 350° C., between about 220° C. and 340° C., between about 230° C. and 330° C. or between about 240° C. and 320° C.

[0388] In some embodiments, at least 50%, at least 70%, or at least 90% by weight of the total hydrocarbons in hydrocarbon stream 242 have a carbon number from 8 to 13. About 50% to about 100%, about 60% to about 95%, about 70% to about 90%, or about 75% to 85% by weight of liquid stream may have a carbon number distribution from 8 to 13. At least 50% by weight of the total hydrocarbons in the separated liquid stream may have a carbon number from about 9 to 12 or from 10 to 11.

[0389] In some embodiments, hydrocarbon stream 242 has at most 15%, at most 10%, at most 5% by weight of naphthenes; at least 70%, at least 80%, or at least 90% by weight total paraffins; at most 5%, at most 3%, or at most 1% by weight olefins; and at most 30%, at most 20%, or at most 10% by weight aromatics.

[0390] In some embodiments, hydrocarbon stream 242 has a nitrogen compound content of at least 0.01%, at least 0.1% or at least 0.4% by weight nitrogen compound. The separated liquid stream may have a sulfur compound content of at least 0.01%, at least 0.5% or at least 1% by weight sulfur compound.

[0391] Hydrocarbon stream 242 enters hydrotreating unit 244. In hydrotreating unit 244, liquid stream 236 may be hydrotreated to form compounds suitable for processing to hydrogen and/or commercial products.

[0392] Liquid hydrocarbon stream 232 from liquid separation unit 226 may include hydrocarbons having a boiling range distribution from about 25° C. to up to about 538° C. or from about 25° C. to about 500° C. at atmospheric pressure. In some embodiments, liquid hydrocarbon stream 232 includes hydrocarbons having a boiling point up to 260° C. Liquid hydrocarbon stream 232 may include entrained asphaltenes and/or other compounds that may contribute to the instability of hydrocarbon streams. For example, liquid hydrocarbon stream 232 is a naphtha/kerosene fraction that includes entrained, partially dissolved, and/or dissolved asphaltenes and/or high molecular weight compounds that may contribute to phase instability of the liquid hydrocarbon stream. In some embodiments, liquid hydrocarbon stream 232 may include at least 0.5% by weight asphaltenes, 1% by weight asphaltenes or at least 5% by weight asphaltenes. In some embodiments, liquid hydrocarbon stream 232 may include at most 5% by volume, at most 3% by volume, or at most 1% by volume of compounds having a boiling point of at least 335° C., at least 500° C. or at least 750° C. at atmospheric pressure.

[0393] In some embodiments, liquid hydrocarbon stream 232 may include small amounts of dissolved, entrained or solid particulates of metals or metal compounds that may not be removed through conventional filtration methods. Metals and/or metal compounds which may be present in the liquid hydrocarbon stream include iron, copper, mercury, calcium, sodium; silicon or compounds thereof. A total amount of metals and/or metal compounds in the liquid hydrocarbon stream may range from 100 ppbw to about 1000 ppbw.

[0394] As properties of the liquid hydrocarbon stream 232 are changed during processing (for example, TAN, asphaltenes, P-value, olefin content, mobilized fluids content, visbroken fluids content, pyrolyzed fluids content, or combinations thereof), the asphaltenes and other components may become less soluble in the liquid hydrocarbon stream. In some instances, components in the produced fluids and/or components in the separated hydrocarbons may form two phases and/or become insoluble. Formation of two phases, through flocculation of asphaltenes, change in concentration of components in the produced fluids, change in concentration of components in separated hydrocarbons, and/or precipitation of components may cause processing problems (for example, plugging) and/or result in hydrocarbons that do not meet pipeline, transportation, and/or refining specifications. In some embodiments, further treatment of the produced fluids and/or separated hydrocarbons is necessary to produce products with desired properties.

[0395] During processing, the P-value of the separated hydrocarbons may be monitored and the stability of the produced fluids and/or separated hydrocarbons may be assessed. Typically, a P-value that is at most 1.0 indicates that flocculation of asphaltenes from the separated hydrocarbons may occur. If the P-value is initially at least 1.0 and such P-value increases or is relatively stable during heating, then this indicates that the separated hydrocarbons are relatively stable.

[0396] Liquid hydrocarbon stream 232 may be treated to at least partially remove asphaltenes and/or other compounds that may contribute to instability. Removal of the asphaltenes and/or other compounds that may contribute to instability may inhibit plugging in downstream processing units. Removal of the asphaltenes and/or other compounds that may contribute to instability may enhance processing unit efficiencies and/or prevent plugging of transportation pipelines.

[0397] Liquid hydrocarbon stream 232 may enter filtration system 246. Filtration system 246 separates at least a portion of the asphaltenes and/or other compounds that contribute to instability from liquid hydrocarbon stream 232. In some embodiments, filtration system 246 is skid mounted. Skid mounting filtration system 246 may allow the filtration system to be moved from one processing unit to another. In some embodiments, filtration system 246 includes one or more membrane separators, for example, one or more nanofiltration membranes or one or more reverse osmosis membranes. Use of a filtration system that operates at below ambient, ambient, or slightly higher than ambient temperatures may reduce energy costs as compared to conventional catalytic and/or thermal methods to remove asphaltenes from a hydrocarbon stream.

[0398] The membranes may be ceramic membranes and/or polymeric membranes. The ceramic membranes may be ceramic membranes having a molecular weight cut off of at most 2000 Daltons (Da), at most 1000 Da, or at most 500 Da. Ceramic membranes may not swell during removal of the desired materials from a substrate (for example, asphaltenes

from the liquid stream). In addition, ceramic membranes may be used at elevated temperatures. Examples of ceramic membranes include, but are not limited to, nanoporous and/or mesoporous titania, mesoporous gamma-alumina, mesoporous zirconia, mesoporous silica, and combinations thereof.

[0399] Polymeric membranes may include top layers made of dense membrane and base layers (supports) made of porous membranes. The polymeric membranes may be arranged to allow the liquid stream (permeate) to flow first through the top layers and then through the base layer so that the pressure difference over the membrane pushes the top layer onto the base layer. The polymeric membranes are organophilic or hydrophobic membranes so that water present in the liquid stream is retained or substantially retained in the retentate.

[0400] The dense membrane layer of the polymeric membrane may separate at least a portion or substantially all of the asphaltenes from liquid hydrocarbon stream **232**. In some embodiments, the dense polymeric membrane has properties such that liquid hydrocarbon stream **232** passes through the membrane by dissolving in and diffusing through the structure of dense membrane. At least a portion of the asphaltenes may not dissolve and/or diffuse through the dense membrane, thus they are removed. The asphaltenes may not dissolve and/or diffuse through the dense membrane because of the complex structure of the asphaltenes and/or their high molecular weight. The dense membrane layer may include cross-linked structure as described in WO 96/27430 to Schmidt et al., which is incorporated by reference herein. A thickness of the dense membrane layer may range from 1 micrometer to 15 micrometers, from 2 micrometers to 10 micrometers, or from 3 micrometers to 5 micrometers.

[0401] The dense membrane may be made from polysiloxane, poly-di-methyl siloxane, poly-octyl-methyl siloxane, polyimide, polyaramide, poly-tri-methyl silyl propyne, or mixtures thereof. Porous base layers may be made of materials that provide mechanical strength to the membrane. The porous base layers may be any porous membranes used for ultra filtration, nanofiltration, and/or reverse osmosis. Examples of such materials are polyacrylonitrile, polyamideimide in combination with titanium oxide, polyetherimide, polyvinylidenedifluoroide, polytetrafluoroethylene, or combinations thereof.

[0402] During separation of asphaltenes from liquid stream **232**, the pressure difference across the membrane may range from about 0.5 MPa to about 6 MPa, from about 1 MPa to about 5 MPa, or from about 2 MPa to about 4 MPa. A temperature of the unit during separation may range from the pour point of liquid hydrocarbon stream **232** up to 100° C., from about -20° C. to about 100° C., from about 10° C. to about 90° C., or from about 20° C. to about 85° C. During continuous operation, the permeate flux rate may be at most 50% of the initial flux, at most 70% of the initial flux, or at most 90% of the initial flux. A weight recovery of the permeate on feed may range from about 50% by weight to 97% by weight, from about 60% by weight to 90% by weight, or from about 70% by weight to 80% by weight.

[0403] Filtration system **246** may include one or more membrane separators. The membrane separators may include one or more membrane modules. When two or more membrane separators are used, the separators may be arranged in a parallel-operated (groups of) membrane separators that include a single separation step. In some embodiments, two or more sequential separation steps are performed, where the

retentate of the first separation step is used as the feed for a second separation step. Examples of membrane modules include, but are not limited to, spirally wound modules, plate and frame modules, hollow fibers, and tubular modules. Membrane modules are described in Encyclopedia of Chemical Engineering, 4th Ed., 1995, John Wiley & Sons Inc., Vol. 16, pages 158-164. Examples of spirally wound modules are described in, for example, WO/2006/040307 to Den Boestert et al., U.S. Pat. No. 5,102,551 to Pasternak; U.S. Pat. No. 5,093,002 to Pasternak; U.S. Pat. No. 5,133,851 to Bitter et al.; U.S. Pat. No. 5,275,726 to Feimer et al.; U.S. Pat. No. 5,458,774 to Mannapperuma; and U.S. Pat. No. 7,351,873 to Cederløf et al., all of which are incorporated by reference herein.

[0404] In some embodiments, a spirally wound module is used when a dense membrane is used in filtration system **246**. A spirally wound module may include a membrane assembly of two membrane sheets between which a permeate spacer sheet is sandwiched. The membrane assembly may be sealed at three sides. The fourth side is connected to a permeate outlet conduit such that the area between the membranes is in fluid communication with the interior of the conduit. A feed spacer sheet may be arranged on top of one of the membranes. The assembly with feed spacer sheet is rolled up around the permeate outlet conduit to form a substantially cylindrical spirally wound membrane module. The feed spacer may have a thickness of at least 0.6 mm, at least 1 mm, or at least 3 mm to allow sufficient membrane surface to be packed into the spirally wound module. In some embodiments, the feed spacer is a woven feed spacer. During operation, the feed mixture may be passed from one end of the cylindrical module between the membrane assemblies along the feed spacer sheet sandwiched between feed sides of the membranes. Part of the feed mixture passes through either one of the membrane sheets to the permeate side. The resulting permeate flows along the permeate spacer sheet into the permeate outlet conduit.

[0405] In some embodiments, the membrane separation is a continuous process. Liquid stream **232** passes over the membrane due to the pressure difference to obtain filtered liquid stream **248** (permeate) and/or recycle liquid stream **250** (retentate). In some embodiments, filtered liquid stream **248** may have reduced concentrations of asphaltenes and/or high molecular weight compounds that may contribute to phase instability. Continuous recycling of recycle liquid stream **250** through the filter system can increase the production of filtered liquid stream **248** to as much as 95% of the original volume of filtered liquid stream **248**. Recycle liquid stream **250** may be continuously recycled through a spirally wound membrane module for at least 10 hours, for at least one day, or for at least one week without cleaning the feed side of the membrane. The flow rate of **250** is used to set a certain required fluid velocity through the membrane modules). The permeate may have a final boiling point of at most 470° C., at most 450° C., or at most at most 420° C. The permeate may have a final boiling point range from at least 25° C. to about 470° C., from about 50° C. to about 450° C., or at least 75° C. to about 420° C. The permeate may have from about 0.001% to about 5%, from about 0.01% to about 3%, or from about 0.1% to about 1%, by volume of compounds having a boiling point of at least 335° C. The permeate may have undetectable amounts of asphaltenes or substantially undetectable amounts of asphaltenes. The permeate may have a total metal content that is less than about 60% on a weight basis than the

metal content of the liquid hydrocarbon stream. For example, the permeate may have a total metal content from about 1 ppbw to about 600 ppbw, from about 10 ppbw to about 300 ppbw, or from about 100 to about 150 ppbw.

[0406] Upon completion of the filtration, asphaltene enriched stream 252 (retentate) may include a high concentration of asphaltenes and/or high molecular weight compounds. In some embodiments, the retentate has at least 50% by volume of compounds having a boiling point of at least 700° C. In an embodiment, the retentate has at least 50%, at least 70%, at least 80%, or at least 90% by volume of compounds having a boiling point of at least 325° C. In an embodiment, the retentate has at least 50% by volume of compounds having a boiling point of at least 350° C., at least 400° C., or at least 700° C. In an embodiment, the permeate has at most 2% by volume of compounds having a boiling point of at least 335° C. and the retentate has at least 25% by volume of compounds having a boiling point of at least 750° C. Asphaltene enriched stream 252 may be provided to separation unit 238 or to other units for further processing.

[0407] At least a portion of filtered liquid stream 248 may be sent to hydrotreating unit 244 for further processing. In some embodiments, at least a portion of filtered liquid stream 248 may be sent to other processing units.

[0408] In some embodiments, at least a portion of or substantially all of filtered liquid stream 248 enters separation unit 254. In separation unit 254, filtered liquid stream 248 may be separated into hydrocarbon stream 256 and liquid hydrocarbon stream 258. Hydrocarbon stream 268 may be rich in aromatic hydrocarbons. Liquid hydrocarbon stream 258 may include a small amount of aromatic hydrocarbons. Liquid hydrocarbon stream 258 may include hydrocarbons having a boiling point up to 260° C. Liquid hydrocarbon stream 258 may enter hydrotreating unit 244 and/or other processing units.

[0409] Hydrocarbon stream 256 may include aromatic hydrocarbons and hydrocarbons having a boiling point up to about 260° C. A content of aromatics in aromatic rich stream 256 may be at most 90%, at most 70%, at most 50%, or most 10% of the aromatic content of filtered liquid stream 248, as measured by UV analysis such as method SMS-2714. Aromatic rich stream 256 may be suitable for use as a diluent for undesirable streams that may not otherwise be suitable for additional processing. The undesirable streams may have low P-values, phase instability, and/or asphaltenes. Addition of aromatic rich stream 256 to the undesirable streams may allow the undesirable streams to be processed and/or transported, thus increasing the economic value of the stream undesirable streams. Aromatic rich stream 256 may be sold as a diluent and/or used as a diluent for produced fluids. All or a portion of aromatic rich stream 254 may be recycled to separation unit 226.

[0410] In some embodiments, membrane separation unit 254 includes one or more membrane separators, for example, one or more nanofiltration membranes and/or one or more reverse osmosis membranes. The membrane may be a ceramic membrane and/or a polymeric membrane. The ceramic membrane may be a ceramic membrane having a molecular weight cut off of at most 2000 Daltons (Da), at most 1000 Da, or at most 500 Da.

[0411] The polymeric membrane includes a top layer made of a dense membrane and a base layer (support) made of a porous membrane. The polymeric membrane may be arranged to allow the liquid stream (permeate) to flow first

through the dense membrane top layer and then through the base layer so that the pressure difference over the membrane pushes the top layer onto the base layer. The dense polymeric membrane has properties such that as liquid hydrocarbon stream 248 passes through the membrane aromatic hydrocarbons are selectively separated from the liquid hydrocarbon stream to form aromatic rich stream 256. In some embodiments, the dense membrane layer may separate at least a portion of or substantially all of the aromatics from liquid hydrocarbon stream 248. The dense membrane may be a silicon based membrane, a polyamide based membrane and/or a polyol membrane. Aromatic selective membranes may be purchased from W. R. Grace & Co. (New York, USA), MTR-Inc, California, USA PolyAn (Berlin, Germany), GMT, Rheinfelden, Germany and/or Borsig Membrane Technology (Berlin, Germany).

[0412] Liquid stream 260 (retentate) from membrane separation unit 254 may be recycled back to the membrane separation unit. Continuous recycling of recycle liquid stream 260 idem through nanofiltration system can increase the production of aromatic rich stream 256 to as much as 95% of the original volume of the filtered liquid stream. Recycle liquid stream 260 may be continuously recycled through a spirally wound membrane module for at least 10 hours, for at least one day, for at least one week or until the desired content of aromatics in aromatic rich stream 256 is obtained. Upon completion of the filtration, or when the retentate includes an acceptable amount of aromatics, liquid stream 260 (retentate) from separation unit 254 may be sent to hydrotreating unit 244 and/or other processing units.

[0413] Membranes of separation unit 254 may be ceramic membranes and/or polymeric membranes. During separation of aromatic hydrocarbons from liquid stream 248 in separation unit 254, the pressure difference across the membrane may range from about 0.5 MPa to about 6 MPa, from about 1 MPa to about 5 MPa, or from about 2 MPa to about 4 MPa. Temperature of separation unit 254 during separation may range from the pour point of the liquid hydrocarbon stream 248 up to 100° C., from about -20° C. to about 100° C., from about 10° C. to about 90° C., or from about 20° C. to about 85° C. During a continuous operation, the permeate flux rate may be at most 50% of the initial flux, at most 70% of the initial flux, or at most 90% of the initial flux. A weight recovery of the permeate on feed may range from about 50% by weight to 97% by weight, from about 60% by weight to 90% by weight, or from about 70% by weight to 80% by weight.

[0414] In some embodiments, liquid hydrocarbon streams produced from a formation may include organonitrogen compounds. Organonitrogen compounds are known to poison precious metal catalyst used for treating hydrocarbon streams to make products suitable for commercial sale and/or transportation (for example, transportation fuels and/or lubricating oils). The formation fluids may include nitrogen levels such that process facilities may deem the fluid unsuitable for processing.

[0415] Removal of organonitrogen compounds from the liquid hydrocarbon stream prior to catalytic treatment of the liquid hydrocarbon streams is desirable. Organonitrogen compounds may be removed through catalytic hydrogenation methods and/or solvent extraction methods. Catalytic hydrogenation methods require high temperatures and catalyst that are not subject to poisoning by nitrogen compounds. The catalytic hydrogenation methods may require high temperatures and/or pressures in addition to requiring high amounts

of hydrogen. Hydrogen may not be readily available and/or may need to be manufactured. Since hydrogen has to be supplied for denitrogenation, the use of high amounts of hydrogen may increase the overall cost for removal of nitrogen from the fluids such that process facilities deem the fluids unsuitable.

[0416] Liquid hydrocarbon streams may be extracted with aqueous acid streams to produce a hydrocarbon stream having a minimal amount of organonitrogen compounds and an aqueous stream. The aqueous stream may contain organonitrogen salts. Further processing of the aqueous stream (e.g., distillation and/or treatment with base) may result production of a stream rich in organonitrogen compounds. The stream rich in organonitrogen stream may be used as diluent for heavy oil and/or sent to other processing units. U.S. Pat. No. 4,287,051 to Curtin describes a method of denitrogenating viscous oils containing a relatively high content of nitrogenous compounds by extracting nitrogenous compounds from a first portion of a viscous oil with an operable acid solvent to produce a raffinate oil having a relatively low concentration of nitrogenous compounds and an extract stream having a high concentration of nitrogenous compounds. The acid solvent is recovered from the extract stream, simultaneously producing a small volume stream of low viscosity oil containing a high concentration of the nitrogenous compounds and referred to as a high nitrogen content oil. The low viscosity high nitrogen content oil is admixed with the remaining first high viscosity bottoms to provide a pumpable mixed stream. Although, aqueous extraction and/or hydrogenation of hydrocarbon streams may produce liquid hydrocarbon streams having a low organonitrogen content, more efficient processes and less costly processes to treat the high nitrogen content oil are desirable. In addition, processes that allow for recycle of waste or low value streams are desirable.

[0417] In some embodiments, liquid stream 236 includes organonitrogen compounds. In some embodiments, liquid stream 236 includes from about 0.1% to greater than 2% by weight nitrogen compounds. In some embodiments, liquid stream 236 includes from about 0.2% to about 1.5% or from 0.5% to about 1% by weight nitrogen compounds. Organonitrogen compounds, for example, alkyl amines, aromatic amines, alkyl amides, aromatic amides, pyridines, pyrazoles, and oxazoles may poison precious metal catalyst used for treating hydrocarbon streams to make products suitable for commercial sale and/or transportation (for example, transportation fuels and/or lubricating oils). Removal of organonitrogen compounds from the liquid hydrocarbon stream prior to catalytic treatment of the liquid hydrocarbon stream may enhance catalyst life of downstream processes. Removal of organonitrogen compounds may allow less severe conditions be used in downstream applications.

[0418] As shown in FIG. 3, liquid stream 236 enters separation unit 262. In some embodiments, liquid stream 236 is passed through one or more filtration units in separation unit 262 to remove solids from the liquid stream. In separation unit 262, liquid stream 236 may be treated with aqueous acid solution 264 to form an aqueous stream 266 and non-aqueous stream 268. In some embodiments, a volume ratio of liquid stream to aqueous acid solution ranges from 0.2 to 0.3 or is about 0.25. Treatment of liquid stream 236 with aqueous acid solution 264 may be conducted at a temperature ranging from about 90° C. to about 150° C. at a pressures ranging from about 0.3 MPa to about 0.4 MPa.

[0419] Non-aqueous stream 268 may include non-organonitrogen hydrocarbons. In some embodiments, non-organonitrogen hydrocarbons include compounds that contain only hydrogen and carbon. In some embodiments, non-aqueous stream 268 contains at most 0.01% by weight organonitrogen compounds. In some embodiments, non-aqueous stream 268 contains from about 200 ppmw to about 1000 ppmw, from about 300 ppmw to about 800 ppmw, or from about 500 ppmw to about 700 ppm organonitrogen compounds. Non-aqueous stream 268 may enter hydrotreating unit 244 for further processing to make products suitable for transportation and/or sale. In some embodiments, further processing of non-aqueous stream 268 is not necessary.

[0420] Aqueous acid solution 264 includes water and acids suitable to complex with nitrogen compounds (for example, sulfuric acid, phosphoric acid, acetic acid, formic acid, other suitable acidic compounds or mixtures thereof). Aqueous stream 266 includes salts of the organonitrogen compounds and acid and water. At least a portion of aqueous stream 266 is sent to separation unit 270. In separation unit 270, aqueous stream 266 is separated (for example, distilled) to form aqueous acid stream 264' and concentrated organonitrogen stream 272. Concentrated organonitrogen stream 272 includes organonitrogen compounds, water, and/or acid. Separated aqueous stream 264' may be introduced into separation unit 262. In some embodiments, separated aqueous stream 264' is combined with aqueous acid solution 264 prior to entering the separation unit.

[0421] In some embodiments, at least a portion of aqueous stream 266 and/or concentrated organonitrogen stream 272 are introduced in a hydrocarbon portion or layer of subsurface formation that has been at least partially treated by an in situ heat treatment process. Aqueous stream 266 and/or concentrated organonitrogen stream 272 may be heated prior to injection in the formation. In some embodiments, the hydrocarbon portion or layer In some embodiments, at least a portion of aqueous stream 266 and/or concentrated organonitrogen stream 272 are introduced in a hydrocarbon portion or layer of subsurface formation that has been at least partially treated by an in situ heat treatment process. Aqueous stream 266 and/or concentrated organonitrogen stream 272 may be heated prior to injection in the formation. In some embodiments, the hydrocarbon portion or layer includes a shale and/or nahcolite (for example, a nahcolite zone in the Piceance Basin). In some embodiments, the aqueous stream 266 and/or concentrated organonitrogen stream 272 is used a part of the water source for solution mining nahcolite from the formation. In some embodiments, the aqueous stream 266 and/or concentrated organonitrogen stream 272 is introduced in a portion of a formation that contains nahcolite after at least a portion of the nahcolite has been removed. In some embodiments, the aqueous stream 266 and/or concentrated organonitrogen stream 272 is introduced in a portion of a formation that contains nahcolite after at least a portion of the nahcolite has been removed and/or the portion has been at least partially treated using an in situ heat treatment process. The hydrocarbon layer may be heated to temperatures above 200° C. prior to introduction of the aqueous stream. Addition of streams that include organonitrogen compounds may increase the permeability of the hydrocarbon layer (for example, increase the permeability of the oil shale layer), thus flow of formation fluids from the heated hydrocarbon layer to other sections of the formation may be improved. In the heated formation, the organonitrogen compounds may form non-nitrogen contain-

ing hydrocarbons, amines, and/or ammonia and at least some of such non-nitrogen containing hydrocarbons, amines and/or ammonia may be produced. In some embodiments, at least some of the acid used in the extraction process is produced. Treatment of the liquid stream as described to produce a stream suitable for further processing and introduction of the organonitrogen stream in a portion of the formation provides an improved, economical process to convert streams deemed unsuitable for processing to be converted to commercial products while overall waste is reduced.

[0422] In some embodiments, streams 242, 248, 258, 268 from processes described in FIGS. 2 and 3 enter hydrotreating unit 244 and are contacted with hydrogen in the presence of one or more catalysts to produce hydrotreated liquid streams 274, 276. Hydrotreating to change one or more desired properties of the crude feed to meet transportation and/or refinery specifications using known hydrodemetallation, hydrodesulfurization, hydrodenitrofication techniques. Methods to change one or more desired properties of the crude feed are described in U.S. Published Patent Application No. 2009-0071652 to Vinegar et al.

[0423] In some embodiments, non-aqueous stream 268 is hydrotreated in hydrotreating unit 244 to produce hydrotreated liquid stream 274. Hydrotreated liquid stream 274 has a nitrogen compound content of at most 200 ppm by weight, at most 150 ppm, at most 110 ppm, at most 50 ppm, or at most 10 ppm of nitrogen compounds. The hydrotreated liquid stream may have a sulfur compound content of at most 1000 ppm, at most 500 ppm, at most 300 ppm, at most 100 ppm, or at most 10 ppm by weight of sulfur compounds.

[0424] Asphalt/bitumen compositions are a commonly used material for construction purposes, such as road pavement and/or roofing material. Residues from fractional and/or vacuum distillation may be used to prepare asphalt/bitumen compositions. Alternatively, asphalt/bitumen used in asphalt/bitumen compositions may be obtained from natural resources or by treating a crude oil in a de-asphalting unit to separate the asphalt/bitumen from lighter hydrocarbons in the crude oil. Asphalt/bitumen alone, however, often does not possess all the physical characteristics desirable for many construction purposes. Asphalt/bitumen may be susceptible to moisture loss, permanent deformation (for example, ruts and/or potholes), and/or cracking. Modifiers may be added to asphalt/bitumen to form asphalt/bitumen compositions to improve weatherability of the asphalt/bitumen compositions. Examples, of modifiers include binders, adhesion improvers, antioxidants, extenders, fibers, fillers, oxidants, or combinations thereof. Examples adhesion improvers include fatty acids, inorganic acids, organic amines, amides, phenols, and polyamidoamines. These compositions may have improved characteristics as compared to asphalt/bitumen alone. U.S. Pat. No. 4,325,738 to Plancher et al. describes addition of fractions removed from shale oil that contain high amounts of nitrogen may be used as moisture damage inhibiting agents in asphalt/bitumen compositions. The high nitrogen fractions may be obtained by distillation and/or acid extraction. While the composition of the prior art is often effective in improving the weatherability of asphalt-aggregate compositions, asphalt/bitumen compositions having improved resistance to moisture loss, cracking, and deformation are still needed.

[0425] In some embodiments, a residue stream generated from an in situ heat treatment (ISHT) process and/or through further treatment of the liquid stream generated from an ISHT process is blended with asphalt/bitumen to form an ISHT

residue/asphalt/bitumen composition. The ISHT residue/asphalt/bitumen blend may have enhanced water sensitivity and/or tensile strength. The ISHT residue/asphalt/bitumen blend may absorb less water and/or have improved tensile strength modulus as compared to other asphalt/bitumen blends made with adhesion improvers. Absorption of less water by ISHT residue/asphalt/bitumen blends may decrease cracking and/or pothole formation in paved roads as compared to asphalt/bitumen blends made with conventional adhesion improvers. Use of ISHT residue in asphalt/bitumen compositions may allow the compositions to be made without or with reduced amounts of expensive adhesion improvers.

[0426] As shown in FIG. 2, ISHT residue may be generated as bottoms stream 240 from separator 238, and/or bottoms stream 278 from hydrotreating unit 244. ISHT residue may have at least 50% by weight or at least 80% by weight or at least 90% by weight of hydrocarbons having a boiling point above 538° C. In some embodiments, ISHT residue has an initial boiling point of at least 400° C. as determined by SIMDIS750, about 50% by weight asphaltenes, about 3% by weight saturates, about 10% by weight aromatics, and about 36% by weight resins as determined by SARA analysis. In some embodiments, ISHT residue may have a total metal content of about 1 ppm to about 500 ppm, from about 10 ppm to about 400 ppm, or from about 100 ppm to about 300 ppm of metals from Columns 1-14 of the Periodic Table. In some embodiments, ISHT residue may include about 2 ppm aluminum, about 5 ppm calcium, about 100 ppm iron, about 50 ppm nickel, about 10 ppm potassium, about 10 ppm of sodium, and about 5 ppm vanadium as determined by ICP test method such as ASTM Test Method D5185. ISHT residue may be a hard material. For example, ISHT residue may exhibit a penetration of at most 3 at 60° C. (0.1 mm) as measured by ASTM Test Method D243, and a ring-and-ball (R&B) temperature of about 139° C. as determined by ASTM Test Method D36.

[0427] A blend of ISHT residue and asphalt/bitumen may be prepared by reducing the particle size of the ISHT residue (for example, crushing or pulverizing the ISHT residue) and heating the crushed ISHT residue to soften the ISHT particles. The ISHT residue may melt at temperatures above 200° C. Hot ISHT residue may be added to asphalt/bitumen at a temperature ranging from about 150° C. to about 200° C., from about 180° C. to about 195° C., or from about 185° C. to about 195° C. for a period of time to form an ISHT residue/asphalt/bitumen blend.

[0428] The ISHT residue/asphalt/bitumen composition may include from about 0.001% by weight to about 50% by weight, from about 0.05% by weight to about 25% by weight, or from about 0.1% by weight to about 5% by weight of ISHT residue. The ISHT residue/asphalt/bitumen composition may include from about 99.999% by weight to about 50% by weight, from about 99.05% by weight to about 75% by weight, and from about 99.9% by weight to about 95% by weight of asphalt/bitumen. In some embodiments, the blend may include about 20% by weight ISHT residue and about 80% by weight asphalt/bitumen or about 8% by weight ISHT residue and 92% by weight asphalt/bitumen. In some embodiments, additives may be added to the ISHT residue/asphalt/bitumen composition. Additives include, but are not limited to, antioxidants, extenders, fibers, fillers, oxidants, or mixtures thereof.

[0429] The ISHT residue/asphalt/bitumen composition may be used as a binder in paving and/or roofing applications, for example, road paving, shingles, roofing felts, paints, pipe-

coating, briquettes, thermal and/or phonic insulation, and clay pigeons. In some embodiments, a sufficient amount of ISHT residue may be mixed with asphalt/bitumen to produce an ISHT residue/asphalt/bitumen composition having a 70/100 penetration grade as measured according to EN1426. For example, a mixture of about 8% by weight of ISHT residue and about 91% asphalt/bitumen has a penetration between 70 and 100. The ISHT residue/asphalt/bitumen blend of 70/100 penetration grade is suitable for paving applications.

[0430] Many wells are needed for treating the hydrocarbon formation using the in situ heat treatment process. In some embodiments, vertical or substantially vertical wells are formed in the formation. In some embodiments, horizontal or U-shaped wells are formed in the formation. In some embodiments, combinations of horizontal and vertical wells are formed in the formation.

[0431] A manufacturing approach for forming wellbores in the formation may be used due to the large number of wells that need to be formed for the in situ heat treatment process. The manufacturing approach may be particularly applicable for forming wells for in situ heat treatment processes that utilize u-shaped wells or other types of wells that have long non-vertically oriented sections. Surface openings for the wells may be positioned in lines running along one or two sides of the treatment area. FIG. 4 depicts a schematic representation of an embodiment of a system for forming wellbores of the in situ heat treatment process.

[0432] The manufacturing approach for forming wellbores may include: 1) delivering flat rolled steel to near site tube manufacturing plant that forms coiled tubulars and/or pipe for surface pipelines; 2) manufacturing large diameter coiled tubing that is tailored to the required well length using electrical resistance welding (ERW), wherein the coiled tubing has customized ends for the bottom hole assembly (BHA) and hang off at the wellhead; 3) deliver the coiled tubing to a drilling rig on a large diameter reel; 4) drill to total depth with coil and a retrievable bottom hole assembly; 5) at total depth, disengage the coil and hang the coil on the wellhead; 6) retrieve the BHA; 7) launch an expansion cone to expand the coil against the formation; 8) return empty spool to the tube manufacturing plant to accept a new length of coiled tubing; 9) move the gantry type drilling platform to the next well location; and 10) repeat.

[0433] In situ heat treatment process locations may be distant from established cities and transportation networks. Transporting formed pipe or coiled tubing for wellbores to the in situ process location may be untenable due to the lengths and quantity of tubulars needed for the in situ heat treatment process. One or more tube manufacturing facilities **280** may be formed at or near to the in situ heat treatment process location. The tubular manufacturing facility may form plate steel into coiled tubing. The plate steel may be delivered to tube manufacturing facilities **280** by truck, train, ship or other transportation system. In some embodiments, different sections of the coiled tubing may be formed of different alloys. The tubular manufacturing facility may use ERW to longitudinally weld the coiled tubing.

[0434] Tube manufacturing facilities **280** may be able to produce tubing having various diameters. Tube manufacturing facilities may initially be used to produce coiled tubing for forming wellbores. The tube manufacturing facilities may also be used to produce heater components, piping for trans-

porting formation fluid to surface facilities, and other piping and tubing needs for the in situ heat treatment process.

[0435] Tube manufacturing facilities **280** may produce coiled tubing used to form wellbores in the formation. The coiled tubing may have a large diameter. The diameter of the coiled tubing may be from about 4 inches to about 8 inches in diameter. In some embodiments, the diameter of the coiled tubing is about 6 inches in diameter. The coiled tubing may be placed on large diameter reels. Large diameter reels may be needed due to the large diameter of the tubing. The diameter of the reel may be from about 10 m to about 50 m. One reel may hold all of the tubing needed for completing a single well to total depth.

[0436] In some embodiments, tube manufacturing facilities **280** has the ability to apply expandable zonal inflow profiler (EZIP) material to one or more sections of the tubing that the facility produces. The EZIP material may be placed on portions of the tubing that are to be positioned near and next to aquifers or high permeability layers in the formation. When activated, the EZIP material forms a seal against the formation that may serve to inhibit migration of formation fluid between different layers. The use of EZIP layers may inhibit saline formation fluid from mixing with non-saline formation fluid.

[0437] The size of the reels used to hold the coiled tubing may prohibit transport of the reel using standard moving equipment and roads. Because tube manufacturing facility **280** is at or near the in situ heat treatment location, the equipment used to move the coiled tubing to the well sites does not have to meet existing road transportation regulations and can be designed to move large reels of tubing. In some embodiments the equipment used to move the reels of tubing is similar to cargo gantries used to move shipping containers at ports and other facilities. In some embodiments, the gantries are wheeled units. In some embodiments, the coiled tubing may be moved using a rail system or other transportation system.

[0438] The coiled tubing may be moved from the tubing manufacturing facility to the well site using gantries **282**. Drilling gantry **284** may be used at the well site. Several drilling gantries **284** may be used to form wellbores at different locations. Supply systems for drilling fluid or other needs may be coupled to drilling gantries **284** from central facilities **286**.

[0439] Drilling gantry **284** or other equipment may be used to set the conductor for the well. Drilling gantry **284** takes coiled tubing, passes the coiled tubing through a straightener, and a BHA attached to the tubing is used to drill the wellbore to depth. In some embodiments, a composite coil is positioned in the coiled tubing at tube manufacturing facility **280**. The composite coil allows the wellbore to be formed without having drilling fluid flowing between the formation and the tubing. The composite coil also allows the BHA to be retrieved from the wellbore. The composite coil may be pulled from the tubing after wellbore formation. The composite coil may be returned to the tubing manufacturing facility to be placed in another length of coiled tubing. In some embodiments, the BHAs are not retrieved from the wellbores.

[0440] In some embodiments, drilling gantry **284** takes the reel of coiled tubing from gantry **282**. In some embodiments, gantry **282** is coupled to drilling gantry **284** during the formation of the wellbore. For example, the coiled tubing may be fed from gantry **282** to drilling gantry **284**, or the drilling

gantry lifts the gantry to a feed position and the tubing is fed from the gantry to the drilling gantry.

[0441] The wellbore may be formed using the bottom hole assembly, coiled tubing and the drilling gantry. The BHA may be self-seeking to the destination. The BHA may form the opening at a fast rate. In some embodiments, the BHA forms the opening at a rate of about 100 meters per hour.

[0442] After the wellbore is drilled to total depth, the tubing may be suspended from the wellhead. An expansion cone may be used to expand the tubular against the formation. In some embodiments, the drilling gantry is used to install a heater and/or other equipment in the wellbore.

[0443] When drilling gantry 284 is finished at well site 288, the drilling gantry may release gantry 282 with the empty reel or return the empty reel to the gantry. Gantry 282 may take the empty reel back to tube manufacturing facility 280 to be loaded with another coiled tube. Gantries 282 may move on looped path 290 from tube manufacturing facility 280 to well sites 288 and back to the tube manufacturing facility.

[0444] Drilling gantry 284 may be moved to the next well site. Global positioning satellite information, lasers and/or other information may be used to position the drilling gantry at desired locations. Additional wellbores may be formed until all of the wellbores for the in situ heat treatment process are formed.

[0445] In some embodiments, positioning and/or tracking system may be utilized to track gantries 282, drilling gantries 284, coiled tubing reels and other equipment and materials used to develop the in situ heat treatment location. Tracking systems may include bar code tracking systems to ensure equipment and materials arrive where and when needed.

[0446] Directionally drilled wellbores may be formed using steerable motors. Deviations in wellbore trajectory may be made using slide drilling systems or using rotary steerable systems. During use of slide drilling systems, the mud motor rotates the bit downhole with little or no rotation of the drilling string from the surface during trajectory changes. The bottom hole assembly is fitted with a bent sub and/or a bent housing mud motor for directional drilling. The bent sub and the drill bit are oriented in the desired direction. With little or no rotation of the drilling string, the drill bit is rotated with the mud motor to set the trajectory. When the desired trajectory is obtained, the entire drilling string is rotated and drills straight rather than at an angle. Drill bit direction changes may be made by utilizing torque/rotary adjusting to control the drill bit in the desired direction.

[0447] By controlling the amount of wellbore drilled in the sliding and rotating modes, the wellbore trajectory may be controlled. Torque and drag during sliding and rotating modes may limit the capabilities of slide mode drilling. Steerable motors may produce tortuosity in the slide mode. Tortuosity may make further sliding more difficult. Many methods have been developed, or are being developed, to improve slide drilling systems. Examples of improvements to slide drilling systems include agitators, low weight bits, slippery muds, and torque/toolface control systems.

[0448] Limitations in slide drilling led to the development of rotary steerable systems. Rotary steerable systems allow directional drilling with continuous rotation from the surface, thus making the need to slide the drill string unnecessary. Continuous rotation transfers weight to the drill bit more efficiently, thus increasing the rate of penetration and distance

that can be drilled. Current rotary steerable systems may be mechanically and/or electrically complicated with a consequently high cost of delivery.

[0449] Some mechanized drill pipe rotation systems exist such as Slider™ (Slider, LLC, Houston, Tex., U.S.A.), DSCS (directional steering control system) disclosed in U.S. Pat. No. 6,050,348 to Richardson et al., incorporated by reference as if fully set forth herein, and available from Canrig Drilling Technology Ltd. (Magnolia, Tex., U.S.A.), and Wiggle Steer™ (American Augers, Inc., West Salem, Ohio, U.S.A.). These systems replicate the behavior of a driller when the force required to overcome the sliding drag begins to reduce the available weight on bit. The functionality is to “rock” the drilling string forward and backward with rotation to place a portion of the drilling string in rotation and leaving the lower end of the drilling string sliding. This process, however, has drawbacks such as the periodic reversals mean periodic “not rotating” episodes and consequent inefficiency in transfer of force for weight on the drill bit. The rocking also requires “overhead” between drilling string connection torque capacity and operating torque to ensure the drilling string does not become unscrewed. A dual motor rotating steerable system as described herein may reduce or eliminate many of the drawbacks of conventional rotating steerable systems.

[0450] In some embodiments, a dual motor rotary steerable drilling system is used. The dual motor rotary steerable system allows a bent sub and/or bent housing mud motor to change the trajectory of the drilling while the drilling string remains in rotary mode. The dual motor rotary steerable system uses a second motor in the bottom hole assembly to rotate a portion of the bottom hole assembly in a direction opposite to the direction of rotation of the drilling string. The addition of the second motor may allow continuous forward rotation of a drilling string while simultaneously controlling the drill bit and, thus, the directional response of the bottom hole assembly. In some embodiments, the rotation speed of the drilling string is used in achieving drill bit control.

[0451] FIG. 5 depicts a schematic representation of an embodiment of drilling string 292 with dual motors in bottom hole assembly 294. Drilling string 292 is coupled to bottom hole assembly 294. Bottom hole assembly 294 includes motor 296A and motor 296B. Motor 296A may be a bent sub and/or bent housing steerable mud motor. Motor 296A may drive drill bit 298. Motor 296B may operate in a rotation direction that is opposite to the rotation of drilling string 292 and/or motor 296A. Motor 296B may operate at a relatively low rotary speed and have high torque capacity as compared to motor 296A. Bottom hole assembly 294 may include sensing array 300 between motors 296A, motor 296B. Sensing array 300 may include a collar with various directional sensors and telemetry.

[0452] As noted above, motor 296B may rotate in a direction opposite to the rotation of drilling string 292. In this manner, portions of bottom hole assembly 294 beyond motor 296B may have less rotation in the direction of rotation of drilling string 292. In some embodiments, motor 296B is a reverse-rotation low speed motor. The revolutions per minute (rpm) versus differential pressure relationship for bottom hole assembly 294 may be assessed prior to running drilling string 292 and the bottom hole assembly 294 in the formation to determine the differential pressure at neutral drilling speed (when the drilling string speed is equal and opposite to the speed of motor 296B). Measured differential pressure may be

used by a control system during drilling to control the speed of the drilling string relative to the neutral drilling speed.

[0453] In some embodiments, motor 296B is operated at a substantially fixed speed. For example, motor 296B may be operated at a speed of 30 rpm. Other speeds may be used as desired.

[0454] In some embodiments, a mud motor is installed in a bottom hole assembly in an inverted orientation (for example, upside-down from the normal orientation). The inverted mud motor may be operated in a reverse direction of rotation relative to other mud motors, a drill bit, and/or a drilling string. For example, motor 296B, shown in FIG. 5, may be installed in an inverted orientation to produce a relative counter-clockwise rotation in portions of bottom hole assembly 294 distal to motor 296B (see counterclockwise arrow).

[0455] FIG. 6 depicts a schematic representation of an embodiment of drilling string 292 including motor 312 in bottom hole assembly 294. Motor 312 may be a low rpm, high torque motor that includes stator 302, rotor 304, and motor shaft 306. Motor shaft 306 couples to driveshaft 310 of drilling string 292 at connection 308. A bit box may be provided at the end of motor shaft 306. Motor shaft 306 and the bit box may face up-hole. The bit box may be fixed relative to drilling string 292. Stator 302 may rotate counter-clockwise relative to drilling string 292.

[0456] Installing a mud motor in an inverted orientation may allow for the use of off-the-shelf motors to produce counter-rotation and/or non-rotation of selected elements of the bottom hole assembly. During drilling, reactive torque from motor 296A is transferred to motor 312. In some embodiments, a threading kit is used (for example, at connection 308) to adapt a threaded mounting for the mud motor to ensure that a secure connection between an inverted mud motor and its mounting is maintained during drilling. For example, the threading kit may reverse the threads (for example, using left hand threads at connection 308). In some embodiments, the connection includes profile-matched sleeve and/or backoff-protected connection.

[0457] In some embodiments, a tool for steerable drilling is at least 4¾ inches with about 25 rpm at 1500 ft-lbs when flowing at 250 gpm. Such a system may be configured to produce at least 2000 ft-lb torque.

[0458] In some embodiments, the rotation speed of drilling string 292 is used to control the trajectory of the wellbore being formed. For example, drilling string 292 may initially be rotating at 40 rpm, and motor 296B rotates at 30 rpm. The counter-rotation of motor 296B and drilling string 292 results in a forward rotation speed (for example, an absolute forward rotation speed) of 10 rpm in the lower portion of bottom hole assembly 294 (the portion of the bottom hole assembly below motor 296B). When a directional course correction is to be made, the speed of drilling string 292 is changed to the neutral drilling speed. Because drilling string 292 is rotating, there is no need to lift drill bit 298 off the bottom of the borehole. Operating at neutral drilling speed may effectively cancel the torque of the drilling string so that drill bit 298 is subjected to torque induced by motor 296A and the formation.

[0459] One of the problems with existing slide drilling processes is that as the drilling string length increases, it may become more difficult to maintain a stable toolface setting due to torsional energy stored in the drilling string. This torsional energy may cause the drilling string to “wind-up” or store rotations. This wind-up may release unpredictably and cause the end of the drilling string to which the motor is

attached to rotate independent of the drilling string at the surface. The continuous rotation of drilling string 292 keeps windup of the drilling string consistent and stabilizes drill bit 298. Directional changes of drill bit 298 may be made by changing the speed of drilling string 292. Using a dual motor rotary steerable system allows the changing of the direction of the drilling string to occur while the drilling string rotates at or near the normal operating rotation speed of drilling string 292.

[0460] FIG. 7 depicts cumulative time operating at a particular drilling string rotation speed and direction during drilling in conventional slide mode. Most of the time, the surface rpm is zero (for example, slide drilling) while some of the time the operator rotates the string forward or backward to influence the toolface position of the steerable mud motor downhole. FIG. 8 depicts cumulative time at rotation speed during directional change for the dual motor drilling string during the drill bit direction change. Drill bit control may be substantially the same as for conventional slide mode drilling where torque/rotary adjustment is used to control the drill bit in the desired direction, but to the effect that 0 rpm on the x-axis of FIG. 7 becomes N (the neutral drilling string speed) in FIG. 8.

[0461] The connection of bottom hole assembly 294 to drilling string 292 of the dual motor rotary steerable system depicted in FIG. 5 may be subjected to the net effect of all the torque components required to rotate the entire bottom hole assembly (including torque generated at drill bit 298 during wellbore formation). Threaded connections along drilling string 292 may include profile-matched sleeves such as those known in the art for utilities drilling systems.

[0462] In some embodiments, a control system used to control wellbore formation includes a system that sets a desired rotation speed of drilling string 292 when direction changes in trajectory of the wellbore are to be implemented. The system may include fine tuning of the desired drilling string rotation speed. The control system may be configured to assume full autonomous control over the wellbore trajectory during drilling.

[0463] In certain embodiments, drilling string 292 is integrated with position measurement and downhole tools (for example, sensing array 312) to autonomously control the hole path along a designed geometry. An autonomous control system for controlling the path of drilling string 292 may utilize two or more domains of functionality. In one embodiment, a control system utilizes at least three domains of functionality including, but not limited to, measurement, trajectory, and control. Measurement may be made using sensor systems and/or other equipment hardware that assess angles, distances, magnetic fields, and/or other data. Trajectory may include flight path calculation and algorithms that utilize physical measurements to calculate angular and spatial offsets of the drilling string. The control system may implement actions to keep the drilling string in the proper path. The control system may include tools that utilize software/control interfaces built into an operating system of the drilling equipment, drilling string and/or bottom hole assembly.

[0464] In certain embodiments, the control system utilizes position and angle measurements to define spatial and angular offsets from the desired drilling geometry. The defined offsets may be used to determine a steering solution to move the trajectory of the drilling string (thus, the trajectory of the borehole) back into convergence with the desired drilling geometry. The steering solution may be based on an optimum

alignment solution in which a desired rate of curvature of the borehole path is set, and required angle change segments and angle change directions for the path are assessed (for example, by computation).

[0465] In some embodiments, the control system uses a fixed angle change rate associated with the drilling string, assesses the lengths of the sections of the drilling string, and assesses the desired directions of the drilling to autonomously execute and control movement of the drilling string. Thus, the control system assesses position measurements and controls of the drilling string to control the direction of the drilling string.

[0466] In some embodiments, differential pressure or torque across motor 296A and/or motor 296B is used to control the rate of penetration. A relationship between rate of penetration, weight-on-bit, and torque may be assessed for drilling string 292. Measurements of torque and the rate of penetration/weight-on-bit/torque relationship may be used to control the feed rate of drilling string 292 into the formation.

[0467] Accuracy and efficiency in forming wellbores in subsurface formations may be affected by the density and quality of directional data during drilling. The quality of directional data may be diminished by vibrations and angular accelerations during rotary drilling, especially during rotary drilling segments of wellbore formation using slide mode drilling.

[0468] In certain embodiments, the quality of the data assessed during rotary drilling is increased by installing directional sensors in a non-rotating housing. FIG. 9 depicts an embodiment of drilling string 292 with non-rotating sensor 314. Non-rotating sensor 314 is located behind motor 296. Motor 296 may be a steerable motor. Motor 296 is located behind drill bit 298. In certain embodiments, sensor 314 is located between non-magnetic components in drilling string 292.

[0469] In some embodiments, non-rotating sensor 314 is located in a sleeve over motor 296. In some embodiments, non-rotating sensor 314 is run on a bottom hole assembly for improved data assessment. In an embodiment, a non-rotating sensor is coupled to and/or driven by a motor that produces relative counter-rotation of the sensor relative to other components of the bottom hole assembly. For example, a sensor may be coupled to the motor having a rotation speed equal and opposite to that of the bottom hole assembly housing to which it is attached so that the absolute rotation speed of the sensor is or is substantially zero. In certain embodiments, the motor for a sensor is a mud motor installed in an inverted orientation such as described above relative to FIG. 5.

[0470] In certain embodiments, non-rotating sensor 314 includes one or more transceivers for communicating data either into drilling string 292 within the bottom hole assembly or to similar transceivers in nearby boreholes. The transceivers may be used for telemetry of data and/or as a means of position assessment or verification. In certain embodiments, use of non-rotating sensor 314 is used for continuous position measurement. Continuous position measurement may be useful in control systems used for drilling position systems and/or umbilical position control. In certain embodiments, continuous magnetic ranging is possible using the embodiments depicted in FIG. 9. For example, continuous magnetic ranging may include embodiments described herein such as where a reference magnetic field is generated by passing current through one or more heaters, conductors, and/or casing in adjacent holes/wells.

[0471] In some embodiments, an automatic position control system in combination with a rack and pinion drilling system may be used for forming wellbores in a formation. Use of an automatic position control and/or measurement system in combination with a rack and pinion drilling system may allow wellbores to be drilled more accurately than drilling using manual positioning and calibration. For example, the automatic position system may be continuously and/or semi-continuously calibrated during drilling. FIG. 10 depicts a schematic of a portion of a system including a rack and pinion drive system. Rack and pinion drive system 316 includes, but is not limited to, rack 318, carriage 320, chuck drive system 322, and circulating sleeve 324. Chuck drive system 322 may hold tubular 326. Push/pull capacity of a rack and pinion type system may allow enough force (for example, about 5 tons) to push tubulars into wellbores so that rotation of the tubulars is not necessary. A rack and pinion system may apply downward force on the drill bit. The force applied to the drill bit may be independent of the weight of the drilling string (tubulars) and/or collars. In certain embodiments, collar size and weight is reduced because the weight of the collars is not needed to enable drilling operations. Drilling wellbores with long horizontal portions may be performed using rack and pinion drilling systems because of the ability of the drilling systems to apply force to the drilling bit independent of the vertical length of drill string available to provide weight on bit.

[0472] Rack and pinion drive system 316 may be coupled to automatic position control system 328. Automatic position control system 328 may include, but is not limited to, rotary steerable systems, dual motor rotary steerable systems, and/or hole measurement systems. In some embodiments, a measurement system includes one or more sensors, including, but not limited to, magnetic ranging sensors, non-rotating sensors, and/or canted accelerometers. In some embodiments, one or more heaters are included in one or more tubulars of the rack and pinion drive system. In some embodiments, hole measurement systems are positioned in the heaters.

[0473] In some embodiments, a hole measuring system includes one or more canted accelerometers. Use of canted accelerometers may allow for surveying of a shallow portion of the formation. For example, shallow portions of the formation may have steel casing strings from drilling operations and/or other wells. The steel casings may affect the use of magnetic survey tools in determining the direction of deflection incurred during drilling. Canted accelerometers may be positioned in a bottom hole assembly of a drilling system (for example, a rack and pinion drilling system) with the surface as reference of tubular rotational position. Positioning the canted accelerometers in a bottom hole assembly may allow accurate measurement of inclination and direction of a hole regardless of the influence of nearby magnetic interference sources (for example, casing strings). In some embodiments, the relative rotational position of the tubular is monitored by measuring and tracking incremental rotation of the shaft. By monitoring the relative rotation of tubulars added to existing tubulars, more accurate positioning of tubulars may be achieved. Such monitoring may allow tubulars to be added in a continuous manner.

[0474] In some embodiments, a method of drilling using a rack and pinion system includes continuous downhole measurement. A measurement system may be operated using a predetermined and constant current signal. Distance and direction are calculated continuously downhole. The results

of the calculations are filtered and averaged. A best estimate final distance and direction is reported to the surface. When received on the surface, the known along-hole depth and tubular location may be combined with the calculated distance and direction to calculate X, Y and Z position data.

[0475] During drilling with jointed pipes, the time taken to shut down circulation, add the next pipe, re-establish circulation, and continuation of hole making may require a substantial amount of time, particularly when using two-phase circulation systems. Handling tubulars (for example, pipes) has historically been a large safety risk where manual handling techniques have been used. Coiled tubing drilling has had some success in eliminating the need for making connections and manual tubular handling; however, the inability to rotate and the limitations on practical coil diameters may limit the extent to which it can be used.

[0476] In some embodiments, a drilling sequence is used in which tubulars are added to a string without interrupting the drilling process. The tubulars may include jointed connections that allow the tubulars to be connected under pressure. Such a sequence may allow continuous rotary drilling with large diameter tubulars. The tubulars may include heaters and/or automatic position control systems described herein.

[0477] A continuous rotary drilling system may include a drilling platform, which includes, but is not limited to, one or more platforms, a top drive system, and a bottom drive system. The platform may include a rack to allow multiple independent traversing of components. The top drive system may include an extended drive sub (for example, an extended drive system manufactured by American Augers, West Salem, Ohio, U.S.A.). The top drive system may be, for example, a rotary drive system or a rack and pinion drive system. The bottom drive system may include a chuck drive system and a hydraulic system. The bottom drive system may operate in a similar manner to a rack and pinion drilling system (for example, the rack and pinion system described in FIG. 10). Bottom drive system and top drive system may alternate control of the drilling operation. The chuck drive system may be mounted on a separate carriage. The hydraulic system may include, but is not limited to, one or more motors and a circulating sleeve. The circulating sleeve may allow circulation between tubulars and the annulus. The circulating sleeve may be used to open or shut off production from various intervals in the well. In some embodiments, a system includes a tubular handling system. A tubular handling system may be automated, manually operated, or a combination thereof.

[0478] In some embodiments, a method using a continuous rotary drilling system includes adding a new tubular to an existing tubular coupled to a bottom drive system to form an extended tubular. During drilling while the bottom drive system controls the drilling operation, a new tubular may be positioned in an opening of the circulating sleeve of the bottom drive system. The new tubular may be coupled to a top drive system. The circulating sleeve of the bottom drive system may allow fluid to flow around the two tubulars. The fluid pressure in the circulating sleeve may be at pressures of up to about 13.8 MPa (2000 psi). The circulation sleeve may include one or more valves (for example, UBD circulation or check valves) that facilitate change and/or flow of circulation. The use of valves may assist in maintaining pressure in the system. The pressure applied to the two tubulars in the circulating sleeve may couple (for example, pressure-fit) the two tubulars to form a coupled tubular without interruption of the drilling process. During and/or after coupling the tubulars

together, control of the drilling operation may be transferred from the bottom drive system to the top drive system. Transfer of the drilling operation to the top drive system may allow the bottom drive system to travel up the coupled tubular towards the top drive system without interruption of the drilling process. The bottom drive system may attach to a drive sub of the top drive system and the control of the drilling operation may be transferred from the top drive system to the bottom drive system without interruption of the drilling process. Once drilling control is transferred to the bottom drive system, the top drive system may disconnect from the tubular. The top drive system may then connect to the top of another tubular to continue the process.

[0479] FIGS. 11A-11D depict a schematic of an embodiment of a continuous drilling sequence. FIG. 12 depicts a cut-away view of an embodiment of a circulating sleeve of the bottom drive system depicted in FIGS. 11A-11D. FIG. 13 depicts a schematic of the valve system of the circulating sleeve of the bottom drive system depicted in FIGS. 11A-11D. Referring to FIGS. 11A-11D, the continuous drilling sequence includes bottom (rack and pinion) drive system 316, tubular handling system 330, and top drive system 332. Top drive system 332 includes top circulating sleeve 334 and drive sub 336. Bottom drive system 316 includes bottom circulating sleeve 324 and chuck 322. In some embodiments, the chuck may be on a separate carriage system. As shown in FIGS. 11A-11D, top drive system 332 is at reference line Y and bottom drive system 316 is at reference line Z. It will be understood that reference lines Y and Z are shown for illustrative purposes only, and the heights of the drive systems at various stages in the sequence may be different than those depicted in FIGS. 11A-11D.

[0480] As shown in FIG. 11A, existing tubular 326 is coupled to chuck 322 of bottom drive system 316. Bottom drive system controls the drilling operation that inserts existing tubular 326 in a subsurface formation. During the drilling operation, fluid may enter bottom circulating sleeve 324 through port 346 and flow around existing tubular 326. Fluid may remove heat away from chuck 322 and/or existing tubular 326. Bottom circulating sleeve 324 may include side valve 338 (shown in FIG. 13). Side valve 338 may be a check valve incorporated into a side entry flow and check valve port. Use of side valve 338 and/or top valve 348 (shown in FIG. 13) may facilitate change of circulation entry points and creation of a pressurized system (for example, pressures up to about 13.8 MPa).

[0481] As chuck 322 of bottom drive system 316 continues to control drilling using existing tubular 326, new tubular 340 may be aligned with bottom drive system 316 using tubular handling system 330. Once in position, top drive system 332 may be connected to a top end (for example, a box end) of new tubular 340. As shown in FIG. 11B, top drive system 332 lowers and positions or drops a bottom end of new tubular 340 in opening 344 (depicted in FIG. 12) of circulating sleeve 324 of bottom drive system 316. In some embodiments, bottom circulating sleeve 324 includes side valve 338 (shown in FIG. 13) at port 346 and top entry valve 348 at opening 344 (shown in FIG. 13). Regulation of fluid flow through bottom circulating sleeve 324 using valves 338, 348 may control the pressure in the circulating sleeve. In some embodiments, bottom circulating sleeve 324 may include, and/or operate in conjunction with, one or more valves.

[0482] Opening 344 may include one or more tooljoints 350 (see FIG. 12). Tooljoints 350 may guide entry of new

tubular 340 in an inner section of circulating sleeve. Since circulating sleeve 324 is pressurized, tooljoints 350 may allow equalization of pressure in the sleeve. Equalization of the pressure facilitates moving new tubular 340 past top entry valve 348 and into bottom circulating sleeve 324.

[0483] Once new tubular 340 is in the chamber of bottom circulating sleeve 324, circulation changes to top drive system 332 and fluid flows through port 352 into top circulating sleeve 334 of top drive system 332. In the chamber of bottom circulating sleeve 324, new tubular 340 and existing tubular 326 are coupled to form coupled tubular 354. Coupled tubular 354 includes new tubular 340 and existing tubular 326. After forming coupled tubular 354, chuck 322 of bottom drive system 316 may disconnect from coupled tubular 354, thus relinquishing control of the drilling process to top drive system 332.

[0484] While top drive system 332 controls the drilling process, bottom drive system 316 may be actuated to travel upward (see arrow shown in FIG. 11C) toward top drive system 332 along the length of coupled tubular 354. As bottom circulating system sleeve 324 of bottom drive system 316 comes into proximity with drive sub 336 of top drive system 332, fluid from top drive system 332 may be flowing from top circulating sleeve 334 of top drive system 332 through top valve 348 (shown in FIG. 13). Bottom circulating sleeve 324 may be pressurized and side valve 338 (shown in FIG. 13) may open to provide flow. Top valve 348 (shown in FIG. 13) may shut and/or partially close as side valve 338 opens to provide flow to top circulating sleeve 334. Circulation may be slowed or discontinued through top drive system 332. As circulation is stopped through top drive system 332, top valve 348 may close completely and all fluid may be furnished through side valve 338 from port 346. When bottom drive system 316 reaches the top of coupled tubular 354, bottom drive system 316 may engage drive sub 336. Coupled tubular 354 may disengage from drive sub 336 and engage with chuck 322 while bottom drive system 316 resumes control of the drilling operation. Chuck 322 transfers force to couple tubular 354 to continue the drilling process.

[0485] Once disengaged from coupled tubular 354, top drive system 332 may be raised (see up arrow) relative to bottom drive system 316 (for example, until top drive system 332 reaches reference line Y as shown in FIG. 11D). Bottom drive system 316 may be lowered to push coupled tubular 354 downward into the formation (see down arrows in FIG. 11D). Bottom drive system 316 may continue to be lowered (for example, until bottom drive system 316 has returned to reference line Z). The sequence described above may be repeated any number of times so as to maintain continuous drilling operations.

[0486] Some wellbores formed in the formation may be used to facilitate formation of a perimeter barrier around a treatment area. Heat sources in the treatment area may heat hydrocarbons in the formation within the treatment area. The perimeter barrier may be, but is not limited to, a low temperature or frozen barrier formed by freeze wells, a wax barrier formed in the formation, dewatering wells, a grout wall formed in the formation, a sulfur cement barrier, a barrier formed by a gel produced in the formation, a barrier formed by precipitation of salts in the formation, a barrier formed by a polymerization reaction in the formation, and/or sheets driven into the formation. Heat sources, production wells, injection wells, dewatering wells, and/or monitoring wells

may be installed in the treatment area defined by the barrier prior to, simultaneously with, or after installation of the barrier.

[0487] A low temperature zone around at least a portion of a treatment area may be formed by freeze wells. In an embodiment, refrigerant is circulated through freeze wells to form low temperature zones around each freeze well. The freeze wells are placed in the formation so that the low temperature zones overlap and form a low temperature zone around the treatment area. The low temperature zone established by freeze wells is maintained below the freezing temperature of aqueous fluid in the formation. Aqueous fluid entering the low temperature zone freezes and forms the frozen barrier. In other embodiments, the freeze barrier is formed by batch operated freeze wells. A cold fluid, such as liquid nitrogen, is introduced into the freeze wells to form low temperature zones around the freeze wells. The fluid is replenished as needed.

[0488] Grout, wax, polymer or other material may be used in combination with freeze wells to provide a barrier for the in situ heat treatment process. The material may fill cavities (vugs) in the formation and reduces the permeability of the formation. The material may have higher thermal conductivity than gas and/or formation fluid that fills cavities in the formation. Placing material in the cavities may allow for faster low temperature zone formation. The material may form a perpetual barrier in the formation that may strengthen the formation. The use of material to form the barrier in unconsolidated or substantially unconsolidated formation material may allow for larger well spacing than is possible without the use of the material. The combination of the material and the low temperature zone formed by freeze wells may constitute a double barrier for environmental regulation purposes. In some embodiments, the material is introduced into the formation as a liquid, and the liquid sets in the formation to form a solid. The material may be, but is not limited to, fine cement, micro fine cement, sulfur, sulfur cement, viscous thermoplastics, and/or waxes. The material may include surfactants, stabilizers or other chemicals that modify the properties of the material. For example, the presence of surfactant in the material may promote entry of the material into small openings in the formation.

[0489] Material may be introduced into the formation through freeze well wellbores. The material may be allowed to set. The integrity of the wall formed by the material may be checked. The integrity of the material wall may be checked by logging techniques and/or by hydrostatic testing. If the permeability of a section formed by the material is too high, additional material may be introduced into the formation through freeze well wellbores. After the permeability of the section is sufficiently reduced, freeze wells may be installed in the freeze well wellbores.

[0490] Material may be injected into the formation at a pressure that is high, but below the fracture pressure of the formation. In some embodiments, injection of material is performed in 16 m increments in the freeze wellbore. Larger or smaller increments may be used if desired. In some embodiments, material is only applied to certain portions of the formation. For example, material may be applied to the formation through the freeze wellbore only adjacent to aquifer zones and/or to relatively high permeability zones (for example, zones with a permeability greater than about 0.1 darcy). Applying material to aquifers may inhibit migration of water from one aquifer to a different aquifer. For material

placed in the formation through freeze well wellbores, the material may inhibit water migration between aquifers during formation of the low temperature zone. The material may also inhibit water migration between aquifers when an established low temperature zone is allowed to thaw.

[0491] In some embodiments, the material used to form a barrier may be fine cement and micro fine cement. Cement may provide structural support in the formation. Fine cement may be ASTM type 3 Portland cement. Fine cement may be less expensive than micro fine cement. In an embodiment, a freeze wellbore is formed in the formation. Selected portions of the freeze wellbore are grouted using fine cement. Then, micro fine cement is injected into the formation through the freeze wellbore. The fine cement may reduce the permeability down to about 10 millidarcy. The micro fine cement may further reduce the permeability to about 0.1 millidarcy. After the grout is introduced into the formation, a freeze wellbore canister may be inserted into the formation. The process may be repeated for each freeze well that will be used to form the barrier.

[0492] In some embodiments, fine cement is introduced into every other freeze wellbore. Micro fine cement is introduced into the remaining wellbores. For example, grout may be used in a formation with freeze wellbores set at about 5 m spacing. A first wellbore is drilled and fine cement is introduced into the formation through the wellbore. A freeze well canister is positioned in the first wellbore. A second wellbore is drilled 10 m away from the first wellbore. Fine cement is introduced into the formation through the second wellbore. A freeze well canister is positioned in the second wellbore. A third wellbore is drilled between the first wellbore and the second wellbore. In some embodiments, grout from the first and/or second wellbores may be detected in the cuttings of the third wellbore. Micro fine cement is introduced into the formation through the third wellbore. A freeze wellbore canister is positioned in the third wellbore. The same procedure is used to form the remaining freeze wells that will form the barrier around the treatment area.

[0493] Fiber optic temperature monitoring systems may also be used to monitor temperatures in heated portions of the formation during in situ heat treatment processes. Temperature monitoring systems positioned in production wells, heater wells, injection wells, and/or monitor wells may be used to measure temperature profiles in treatment areas subjected to in situ heat treatment processes. The fiber of a fiber optic cable used in the heated portion of the formation may be clad with a reflective material to facilitate retention of a signal or signals transmitted down the fiber. In some embodiments, the fiber is clad with gold, copper, nickel, aluminum and/or alloys thereof. The cladding may be formed of a material that is able to withstand chemical and temperature conditions in the heated portion of the formation. For example, gold cladding may allow an optical sensor to be used up to temperatures of 700° C. In some embodiments, the fiber is clad with aluminum. The fiber may be dipped in or run through a bath of liquid aluminum. The clad fiber may then be allowed to cool to secure the aluminum to the fiber. The gold or aluminum cladding may reduce hydrogen darkening of the optical fiber.

[0494] In some embodiments, two or more rows of freeze wells are located about all or a portion of the perimeter of the treatment area to form a thick interconnected low temperature zone. Thick low temperature zones may be formed adjacent to areas in the formation where there is a high flow rate of

aqueous fluid in the formation. The thick barrier may ensure that breakthrough of the frozen barrier established by the freeze wells does not occur.

[0495] In some embodiments, a double barrier system is used to isolate a treatment area. The double barrier system may be formed with a first barrier and a second barrier. The first barrier may be formed around at least a portion of the treatment area to inhibit fluid from entering or exiting the treatment area. The second barrier may be formed around at least a portion of the first barrier to isolate an inter-barrier zone between the first barrier and the second barrier. The inter-barrier zone may have a thickness from about 1 m to about 300 m. In some embodiments, the thickness of the inter-barrier zone is from about 10 m to about 100 m, or from about 20 m to about 50 m.

[0496] The double barrier system may allow greater project depths than a single barrier system. Greater depths are possible with the double barrier system because the stepped differential pressures across the first barrier and the second barrier is less than the differential pressure across a single barrier. The smaller differential pressures across the first barrier and the second barrier make a breach of the double barrier system less likely to occur at depth for the double barrier system as compared to the single barrier system. In some embodiments, additional barriers may be positioned to connect the inner barrier to the outer barrier. The additional barriers may further strengthen the double barrier system and define compartments that limit the amount of fluid that can pass from the inter-barrier zone to the treatment area should a breach occur in the first barrier.

[0497] The first barrier and the second barrier may be the same type of barrier or different types of barriers. In some embodiments, the first barrier and the second barrier are formed by freeze wells. In some embodiments, the first barrier is formed by freeze wells, and the second barrier is a grout wall. The grout wall may be formed of cement, sulfur, sulfur cement, or combinations thereof. In some embodiments, a portion of the first barrier and/or a portion of the second barrier is a natural barrier, such as an impermeable rock formation.

[0498] In some embodiments, one or both barriers may be formed from wellbores positioned in the formation. The position of the wellbores used to form the second barrier may be adjusted relative to the wellbores used to form the first barrier to limit a separation distance between a breach or portion of the barrier that is difficult to form and the nearest wellbore. For example, if freeze wells are used to form both barriers of a double barrier system, the position of the freeze wells may be adjusted to facilitate formation of the barriers and limit the distance between a potential breach and the closest wells to the breach. Adjusting the position of the wells of the second barrier relative to the wells of the first barrier may also be used when one or more of the barriers are barriers other than freeze barriers (for example, dewatering wells, cement barriers, grout barriers, and/or wax barriers).

[0499] In some embodiments, wellbores for forming the first barrier are formed in a row in the formation. During formation of the wellbores, logging techniques and/or analysis of cores may be used to determine the principal fracture direction and/or the direction of water flow in one or more layers of the formation. In some embodiments, two or more layers of the formation may have different principal fracture directions and/or the directions of water flow that need to be addressed. In such formations, three or more barriers may

need to be formed in the formation to allow for formation of the barriers that inhibit inflow of formation fluid into the treatment area or outflow of formation fluid from the treatment area. Barriers may be formed to isolate particular layers in the formation.

[0500] The principal fracture direction and/or the direction of water flow may be used to determine the placement of wells used to form the second barrier relative to the wells used to form the first barrier. The placement of the wells may facilitate formation of the first barrier and the second barrier.

[0501] FIG. 14 depicts a schematic representation of barrier wells **200** used to form a first barrier and barrier wells **200'** used to form a second barrier when the principal fracture direction and/or the direction of water flow is at angle **A** relative to the first barrier. The principal fracture direction and/or direction of water flow is indicated by arrow **356**. The case where angle **A** is 0 is the case where the principal fracture direction and/or the direction of water flow is substantially normal to the barriers. Spacing between two adjacent barrier wells **200** of the first barrier or between barrier wells **200'** of the second barrier are indicated by distance **s**. The spacing **s** may be 2 m, 3 m, 10 m or greater. Distance **d** indicates the separation distance between the first barrier and the second barrier. Distance **d** may be less than **s**, equal to **s**, or greater than **s**. Barrier wells **200'** of the second barrier may have offset distance **od** relative to barrier wells **200** of the first barrier. Offset distance **od** may be calculated by the equation:

$$od = s/2 - d * \tan(A) \quad (\text{EQN. 1})$$

[0502] Using the **od** according to EQN. 1 maintains a maximum separation distance of **s/4** between a barrier well and a regular fracture extending between the barriers. Having a maximum separation distance of **s/4** by adjusting the offset distance based on the principal fracture direction and/or the direction of water flow may enhance formation of the first barrier and/or second barrier. Having a maximum separation distance of **s/4** by adjusting the offset distance of wells of the second barrier relative to the wells of the first barrier based on the principal fracture direction and/or the direction of water flow may reduce the time needed to reform the first barrier and/or the second barrier should a breach of the first barrier and/or the second barrier occur.

[0503] In some embodiments, **od** may be set at a value between the value generated by EQN. 1 and the worst case value. The worst case value of **od** may be if barrier wells **200** of the first freeze barrier and barrier wells **200'** of the second barrier are located along the principal fracture direction and/or direction of water flow (i.e., along arrow **356**). In such a case, the maximum separation distance would be **s/2**. Having a maximum separation distance of **s/2** may slow the time needed to form the first barrier and/or the second barrier, or may inhibit formation of the barriers.

[0504] In some embodiments, the barrier wells for the treatment area are freeze wells. Vertically positioned freeze wells and/or horizontally positioned freeze wells may be positioned around sides of the treatment area. If the upper layer (the overburden) or the lower layer (the underburden) of the formation is likely to allow fluid flow into the treatment area or out of the treatment area, horizontally positioned freeze wells may be used to form an upper and/or a lower barrier for the treatment area. In some embodiments, an upper barrier and/or a lower barrier may not be necessary if the upper layer and/or the lower layer are at least substantially impermeable. If the upper freeze barrier is formed, portions of heat sources, pro-

duction wells, injection wells, and/or dewatering wells that pass through the low temperature zone created by the freeze wells forming the upper freeze barrier wells may be insulated and/or heat traced so that the low temperature zone does not adversely affect the functioning of the heat sources, production wells, injection wells and/or dewatering wells passing through the low temperature zone.

[0505] In situ heat treatment processes and solution mining processes may heat the treatment area, remove mass from the treatment area, and greatly increase the permeability of the treatment area. In certain embodiments, the treatment area after being treated may have a permeability of at least 0.1 darcy. In some embodiments, the treatment area after being treated has a permeability of at least 1 darcy, of at least 10 darcy, or of at least 100 darcy. The increased permeability allows the fluid to spread in the formation into fractures, microfractures, and/or pore spaces in the formation. Outside of the treatment area, the permeability may remain at the initial permeability of the formation. The increased permeability allows fluid introduced to flow easily within the formation.

[0506] In certain embodiments, a barrier may be formed in the formation after a solution mining process and/or an in situ heat treatment process by introducing a fluid into the formation. The barrier may inhibit formation fluid from entering the treatment area after the solution mining and/or in situ heat treatment processes have ended. The barrier formed by introducing fluid into the formation may allow for isolation of the treatment area.

[0507] The fluid introduced into the formation to form a barrier may include wax, bitumen, heavy oil, sulfur, polymer, gel, saturated saline solution, and/or one or more reactants that react to form a precipitate, solid or high viscosity fluid in the formation. In some embodiments, bitumen, heavy oil, reactants and/or sulfur used to form the barrier are obtained from treatment facilities associated with the in situ heat treatment process. For example, sulfur may be obtained from a Claus process used to treat produced gases to remove hydrogen sulfide and other sulfur compounds.

[0508] The fluid may be introduced into the formation as a liquid, vapor, or mixed phase fluid. The fluid may be introduced into a portion of the formation that is at an elevated temperature. In some embodiments, the fluid is introduced into the formation through wells located near a perimeter of the treatment area. The fluid may be directed away from the treatment area. The elevated temperature of the formation maintains or allows the fluid to have a low viscosity so that the fluid moves away from the wells. A portion of the fluid may spread outwards in the formation towards a cooler portion of the formation. The relatively high permeability of the formation allows fluid introduced from one wellbore to spread and mix with fluid introduced from other wellbores. In the cooler portion of the formation, the viscosity of the fluid increases, a portion of the fluid precipitates, and/or the fluid solidifies or thickens so that the fluid forms the barrier to flow of formation fluid into or out of the treatment area.

[0509] In some embodiments, a low temperature barrier formed by freeze wells surrounds all or a portion of the treatment area. As the fluid introduced into the formation approaches the low temperature barrier, the temperature of the formation becomes colder. The colder temperature increases the viscosity of the fluid, enhances precipitation, and/or solidifies the fluid to form the barrier to the flow of formation fluid into or out of the formation. The fluid may

remain in the formation as a highly viscous fluid or a solid after the low temperature barrier has dissipated.

[0510] In certain embodiments, saturated saline solution is introduced into the formation. Components in the saturated saline solution may precipitate out of solution when the solution reaches a colder temperature. The solidified particles may form the barrier to the flow of formation fluid into or out of the formation. The solidified components may be substantially insoluble in formation fluid.

[0511] A potential source of heat loss from the heated formation is due to reflux in wells. Refluxing occurs when vapors condense in a well and flow into a portion of the well adjacent to the heated portion of the formation. Vapors may condense in the well adjacent to the overburden of the formation to form condensed fluid. Condensed fluid flowing into the well adjacent to the heated formation absorbs heat from the formation. Heat absorbed by condensed fluids cools the formation and necessitates additional energy input into the formation to maintain the formation at a desired temperature. Some fluids that condense in the overburden and flow into the portion of the well adjacent to the heated formation may react to produce undesired compounds and/or coke. Inhibiting fluids from refluxing may significantly improve the thermal efficiency of the in situ heat treatment system and/or the quality of the product produced from the in situ heat treatment system.

[0512] For some well embodiments, the portion of the well adjacent to the overburden section of the formation is cemented to the formation. In some well embodiments, the well includes packing material placed near the transition from the heated section of the formation to the overburden. The packing material inhibits formation fluid from passing from the heated section of the formation into the section of the wellbore adjacent to the overburden. Cables, conduits, devices, and/or instruments may pass through the packing material, but the packing material inhibits formation fluid from passing up the wellbore adjacent to the overburden section of the formation.

[0513] In some embodiments, one or more baffle systems may be placed in the wellbores to inhibit reflux. The baffle systems may be obstructions to fluid flow into the heated portion of the formation. In some embodiments, refluxing fluid may reevaporize on the baffle system before coming into contact with the heated portion of the formation.

[0514] In some embodiments, a gas may be introduced into the formation through wellbores to inhibit reflux in the wellbores. In some embodiments, gas may be introduced into wellbores that include baffle systems to inhibit reflux of fluid in the wellbores. The gas may be carbon dioxide, methane, nitrogen or other desired gas. In some embodiments, the introduction of gas may be used in conjunction with one or more baffle systems in the wellbores. The introduced gas may enhance heat exchange at the baffle systems to help maintain top portions of the baffle systems colder than the lower portions of the baffle systems.

[0515] The flow of production fluid up the well to the surface is desired for some types of wells, especially for production wells. Flow of production fluid up the well is also desirable for some heater wells that are used to control pressure in the formation. The overburden, or a conduit in the well used to transport formation fluid from the heated portion of the formation to the surface, may be heated to inhibit condensation on or in the conduit. Providing heat in the overburden,

however, may be costly and/or may lead to increased cracking or coking of formation fluid as the formation fluid is being produced from the formation.

[0516] To avoid the need to heat the overburden or to heat the conduit passing through the overburden, one or more diverters may be placed in the wellbore to inhibit fluid from refluxing into the wellbore adjacent to the heated portion of the formation. In some embodiments, the diverter retains fluid above the heated portion of the formation. Fluids retained in the diverter may be removed from the diverter using a pump, gas lifting, and/or other fluid removal technique. In certain embodiments, two or more diverters that retain fluid above the heated portion of the formation may be located in the production well. Two or more diverters provide a simple way of separating initial fractions of condensed fluid produced from the in situ heat treatment system. A pump may be placed in each of the diverters to remove condensed fluid from the diverters.

[0517] In some embodiments, the diverter directs fluid to a sump below the heated portion of the formation. An inlet for a lift system may be located in the sump. In some embodiments, the intake of the lift system is located in casing in the sump. In some embodiments, the intake of the lift system is located in an open wellbore. The sump is below the heated portion of the formation. The intake of the pump may be located 1 m, 5 m, 10 m, 20 m or more below the deepest heater used to heat the heated portion of the formation. The sump may be at a cooler temperature than the heated portion of the formation. The sump may be more than 10° C., more than 50° C., more than 75° C., or more than 100° C. below the temperature of the heated portion of the formation. A portion of the fluid entering the sump may be liquid. A portion of the fluid entering the sump may condense within the sump. The lift system moves the fluid in the sump to the surface.

[0518] Production well lift systems may be used to efficiently transport formation fluid from the bottom of the production wells to the surface. Production well lift systems may provide and maintain the maximum required well drawdown (minimum reservoir producing pressure) and producing rates. The production well lift systems may operate efficiently over a wide range of high temperature/multiphase fluids (gas/vapor/steam/water/hydrocarbon liquids) and production rates expected during the life of a typical project. Production well lift systems may include dual concentric rod pump lift systems, chamber lift systems and other types of lift systems.

[0519] Temperature limited heaters may be in configurations and/or may include materials that provide automatic temperature limiting properties for the heater at certain temperatures. In certain embodiments, ferromagnetic materials are used in temperature limited heaters. Ferromagnetic material may self-limit temperature at or near the Curie temperature of the material and/or the phase transformation temperature range to provide a reduced amount of heat when a time-varying current is applied to the material. In certain embodiments, the ferromagnetic material self-limits temperature of the temperature limited heater at a selected temperature that is approximately the Curie temperature and/or in the phase transformation temperature range. In certain embodiments, the selected temperature is within about 35° C., within about 25° C., within about 20° C., or within about 10° C. of the Curie temperature and/or the phase transformation temperature range. In certain embodiments, ferromagnetic materials are coupled with other materials (for example, highly conductive materials, high strength materials, corro-

sion resistant materials, or combinations thereof) to provide various electrical and/or mechanical properties. Some parts of the temperature limited heater may have a lower resistance (caused by different geometries and/or by using different ferromagnetic and/or non-ferromagnetic materials) than other parts of the temperature limited heater. Having parts of the temperature limited heater with various materials and/or dimensions allows for tailoring the desired heat output from each part of the heater.

[0520] Temperature limited heaters may be more reliable than other heaters. Temperature limited heaters may be less apt to break down or fail due to hot spots in the formation. In some embodiments, temperature limited heaters allow for substantially uniform heating of the formation. In some embodiments, temperature limited heaters are able to heat the formation more efficiently by operating at a higher average heat output along the entire length of the heater. The temperature limited heater operates at the higher average heat output along the entire length of the heater because power to the heater does not have to be reduced to the entire heater, as is the case with typical constant wattage heaters, if a temperature along any point of the heater exceeds, or is about to exceed, a maximum operating temperature of the heater. Heat output from portions of a temperature limited heater approaching a Curie temperature and/or the phase transformation temperature range of the heater automatically reduces without controlled adjustment of the time-varying current applied to the heater. The heat output automatically reduces due to changes in electrical properties (for example, electrical resistance) of portions of the temperature limited heater. Thus, more power is supplied by the temperature limited heater during a greater portion of a heating process.

[0521] In certain embodiments, the system including temperature limited heaters initially provides a first heat output and then provides a reduced (second heat output) heat output, near, at, or above the Curie temperature and/or the phase transformation temperature range of an electrically resistive portion of the heater when the temperature limited heater is energized by a time-varying current. The first heat output is the heat output at temperatures below which the temperature limited heater begins to self-limit. In some embodiments, the first heat output is the heat output at a temperature about 50° C., about 75° C., about 100° C., or about 125° C. below the Curie temperature and/or the phase transformation temperature range of the ferromagnetic material in the temperature limited heater.

[0522] The temperature limited heater may be energized by time-varying current (alternating current or modulated direct current) supplied at the wellhead. The wellhead may include a power source and other components (for example, modulation components, transformers, and/or capacitors) used in supplying power to the temperature limited heater. The temperature limited heater may be one of many heaters used to heat a portion of the formation.

[0523] In certain embodiments, the temperature limited heater includes a conductor that operates as a skin effect or proximity effect heater when time-varying current is applied to the conductor. The skin effect limits the depth of current penetration into the interior of the conductor. For ferromagnetic materials, the skin effect is dominated by the magnetic permeability of the conductor. The relative magnetic permeability of ferromagnetic materials is typically between 10 and 1000 (for example, the relative magnetic permeability of ferromagnetic materials is typically at least 10 and may be at

least 50, 100, 500, 1000 or greater). As the temperature of the ferromagnetic material is raised above the Curie temperature, or the phase transformation temperature range, and/or as the applied electrical current is increased, the magnetic permeability of the ferromagnetic material decreases substantially and the skin depth expands rapidly (for example, the skin depth expands as the inverse square root of the magnetic permeability). The reduction in magnetic permeability results in a decrease in the AC or modulated DC resistance of the conductor near, at, or above the Curie temperature, the phase transformation temperature range, and/or as the applied electrical current is increased. When the temperature limited heater is powered by a substantially constant current source, portions of the heater that approach, reach, or are above the Curie temperature and/or the phase transformation temperature range may have reduced heat dissipation. Sections of the temperature limited heater that are not at or near the Curie temperature and/or the phase transformation temperature range may be dominated by skin effect heating that allows the heater to have high heat dissipation due to a higher resistive load.

[0524] Curie temperature heaters have been used in soldering equipment, heaters for medical applications, and heating elements for ovens (for example, pizza ovens). Some of these uses are disclosed in U.S. Pat. No. 5,579,575 to Lamome et al.; U.S. Pat. No. 5,065,501 to Henschen et al.; and U.S. Pat. No. 5,512,732 to Yagnik et al., all of which are incorporated by reference as if fully set forth herein. U.S. Pat. No. 4,849,611 to Whitney et al., which is incorporated by reference as if fully set forth herein, describes a plurality of discrete, spaced-apart heating units including a reactive component, a resistive heating component, and a temperature responsive component.

[0525] An advantage of using the temperature limited heater to heat hydrocarbons in the formation is that the conductor is chosen to have a Curie temperature and/or a phase transformation temperature range in a desired range of temperature operation. Operation within the desired operating temperature range allows substantial heat injection into the formation while maintaining the temperature of the temperature limited heater, and other equipment, below design limit temperatures. Design limit temperatures are temperatures at which properties such as corrosion, creep, and/or deformation are adversely affected. The temperature limiting properties of the temperature limited heater inhibit overheating or burnout of the heater adjacent to low thermal conductivity "hot spots" in the formation. In some embodiments, the temperature limited heater is able to lower or control heat output and/or withstand heat at temperatures above 25° C., 37° C., 100° C., 250° C., 500° C., 700° C., 800° C., 900° C., or higher up to 1131° C., depending on the materials used in the heater.

[0526] The temperature limited heater allows for more heat injection into the formation than constant wattage heaters because the energy input into the temperature limited heater does not have to be limited to accommodate low thermal conductivity regions adjacent to the heater. For example, in Green River oil shale there is a difference of at least a factor of 3 in the thermal conductivity of the lowest richness oil shale layers and the highest richness oil shale layers. When heating such a formation, substantially more heat is transferred to the formation with the temperature limited heater than with the conventional heater that is limited by the temperature at low thermal conductivity layers. The heat output along the entire length of the conventional heater needs to

accommodate the low thermal conductivity layers so that the heater does not overheat at the low thermal conductivity layers and burn out. The heat output adjacent to the low thermal conductivity layers that are at high temperature will reduce for the temperature limited heater, but the remaining portions of the temperature limited heater that are not at high temperature will still provide high heat output. Because heaters for heating hydrocarbon formations typically have long lengths (for example, at least 10 m, 100 m, 300 m, 500 m, 1 km or more up to about 10 km), the majority of the length of the temperature limited heater may be operating below the Curie temperature and/or the phase transformation temperature range while only a few portions are at or near the Curie temperature and/or the phase transformation temperature range of the temperature limited heater.

[0527] The use of temperature limited heaters allows for efficient transfer of heat to the formation. Efficient transfer of heat allows for reduction in time needed to heat the formation to a desired temperature. For example, in Green River oil shale, pyrolysis typically requires 9.5 years to 10 years of heating when using a 12 m heater well spacing with conventional constant wattage heaters. For the same heater spacing, temperature limited heaters may allow a larger average heat output while maintaining heater equipment temperatures below equipment design limit temperatures. Pyrolysis in the formation may occur at an earlier time with the larger average heat output provided by temperature limited heaters than the lower average heat output provided by constant wattage heaters. For example, in Green River oil shale, pyrolysis may occur in 5 years using temperature limited heaters with a 12 m heater well spacing. Temperature limited heaters counteract hot spots due to inaccurate well spacing or drilling where heater wells come too close together. In certain embodiments, temperature limited heaters allow for increased power output over time for heater wells that have been spaced too far apart, or limit power output for heater wells that are spaced too close together. Temperature limited heaters also supply more power in regions adjacent the overburden and underburden to compensate for temperature losses in these regions.

[0528] Temperature limited heaters may be advantageously used in many types of formations. For example, in tar sands formations or relatively permeable formations containing heavy hydrocarbons, temperature limited heaters may be used to provide a controllable low temperature output for reducing the viscosity of fluids, mobilizing fluids, and/or enhancing the radial flow of fluids at or near the wellbore or in the formation. Temperature limited heaters may be used to inhibit excess coke formation due to overheating of the near wellbore region of the formation.

[0529] In some embodiments, the use of temperature limited heaters eliminates or reduces the need for expensive temperature control circuitry. For example, the use of temperature limited heaters eliminates or reduces the need to perform temperature logging and/or the need to use fixed thermocouples on the heaters to monitor potential overheating at hot spots.

[0530] In certain embodiments, phase transformation (for example, crystalline phase transformation or a change in the crystal structure) of materials used in a temperature limited heater change the selected temperature at which the heater self-limits. Ferromagnetic material used in the temperature limited heater may have a phase transformation (for example, a transformation from ferrite to austenite) that decreases the magnetic permeability of the ferromagnetic material. This

reduction in magnetic permeability is similar to reduction in magnetic permeability due to the magnetic transition of the ferromagnetic material at the Curie temperature. The Curie temperature is the magnetic transition temperature of the ferrite phase of the ferromagnetic material. The reduction in magnetic permeability results in a decrease in the AC or modulated DC resistance of the temperature limited heater near, at, or above the temperature of the phase transformation and/or the Curie temperature of the ferromagnetic material.

[0531] The phase transformation of the ferromagnetic material may occur over a temperature range. The temperature range of the phase transformation depends on the ferromagnetic material and may vary, for example, over a range of about 5° C. to a range of about 200° C. Because the phase transformation takes place over a temperature range, the reduction in the magnetic permeability due to the phase transformation takes place over the temperature range. The reduction in magnetic permeability may also occur hysteretically over the temperature range of the phase transformation. In some embodiments, the phase transformation back to the lower temperature phase of the ferromagnetic material is slower than the phase transformation to the higher temperature phase (for example, the transition from austenite back to ferrite is slower than the transition from ferrite to austenite). The slower phase transformation back to the lower temperature phase may cause hysteretic operation of the heater at or near the phase transformation temperature range that allows the heater to slowly increase to higher resistance after the resistance of the heater reduces due to high temperature.

[0532] In some embodiments, the phase transformation temperature range overlaps with the reduction in the magnetic permeability when the temperature approaches the Curie temperature of the ferromagnetic material. The overlap may produce a faster drop in electrical resistance versus temperature than if the reduction in magnetic permeability is solely due to the temperature approaching the Curie temperature. The overlap may also produce hysteretic behavior of the temperature limited heater near the Curie temperature and/or in the phase transformation temperature range.

[0533] In certain embodiments, the hysteretic operation due to the phase transformation is a smoother transition than the reduction in magnetic permeability due to magnetic transition at the Curie temperature. The smoother transition may be easier to control (for example, electrical control using a process control device that interacts with the power supply) than the sharper transition at the Curie temperature. In some embodiments, the Curie temperature is located inside the phase transformation range for selected metallurgies used in temperature limited heaters. This phenomenon provides temperature limited heaters with the smooth transition properties of the phase transformation in addition to a sharp and definite transition due to the reduction in magnetic properties at the Curie temperature. Such temperature limited heaters may be easy to control (due to the phase transformation) while providing finite temperature limits (due to the sharp Curie temperature transition). Using the phase transformation temperature range instead of and/or in addition to the Curie temperature in temperature limited heaters increases the number and range of metallurgies that may be used for temperature limited heaters.

[0534] In certain embodiments, alloy additions are made to the ferromagnetic material to adjust the temperature range of the phase transformation. For example, adding carbon to the ferromagnetic material may increase the phase transforma-

tion temperature range and lower the onset temperature of the phase transformation. Adding titanium to the ferromagnetic material may increase the onset temperature of the phase transformation and decrease the phase transformation temperature range. Alloy compositions may be adjusted to provide desired Curie temperature and phase transformation properties for the ferromagnetic material. The alloy composition of the ferromagnetic material may be chosen based on desired properties for the ferromagnetic material (such as, but not limited to, magnetic permeability transition temperature or temperature range, resistance versus temperature profile, or power output). Addition of titanium may allow higher Curie temperatures to be obtained when adding cobalt to 410 stainless steel by raising the ferrite to austenite phase transformation temperature range to a temperature range that is above, or well above, the Curie temperature of the ferromagnetic material.

[0535] In some embodiments, temperature limited heaters are more economical to manufacture or make than standard heaters. Typical ferromagnetic materials include iron, carbon steel, or ferritic stainless steel. Such materials are inexpensive as compared to nickel-based heating alloys (such as nichrome, Kanthal™ (Bulten-Kanthal AB, Sweden), and/or LOHM™ (Driver-Harris Company, Harrison, N.J., U.S.A.)) typically used in insulated conductor (mineral insulated cable) heaters. In one embodiment of the temperature limited heater, the temperature limited heater is manufactured in continuous lengths as an insulated conductor heater to lower costs and improve reliability.

[0536] In some embodiments, the temperature limited heater is placed in the heater well using a coiled tubing rig. A heater that can be coiled on a spool may be manufactured by using metal such as ferritic stainless steel (for example, 409 stainless steel) that is welded using electrical resistance welding (ERW). U.S. Pat. No. 7,032,809 to Hopkins, which is incorporated by reference as if fully set forth herein, describes forming seam-welded pipe. To form a heater section, a metal strip from a roll is passed through a former where it is shaped into a tubular and then longitudinally welded using ERW.

[0537] In some embodiments, a composite tubular may be formed from the seam-welded tubular. The seam-welded tubular is passed through a second former where a conductive strip (for example, a copper strip) is applied, drawn down tightly on the tubular through a die, and longitudinally welded using ERW. A sheath may be formed by longitudinally welding a support material (for example, steel such as 347H or 347HH) over the conductive strip material. The support material may be a strip rolled over the conductive strip material. An overburden section of the heater may be formed in a similar manner.

[0538] In certain embodiments, the overburden section uses a non-ferromagnetic material such as 304 stainless steel or 316 stainless steel instead of a ferromagnetic material. The heater section and overburden section may be coupled using standard techniques such as butt welding using an orbital welder. In some embodiments, the overburden section material (the non-ferromagnetic material) may be pre-welded to the ferromagnetic material before rolling. The pre-welding may eliminate the need for a separate coupling step (for example, butt welding). In an embodiment, a flexible cable (for example, a furnace cable such as a MGT 1000 furnace cable) may be pulled through the center after forming the tubular heater. An end bushing on the flexible cable may be welded to the tubular heater to provide an electrical current

return path. The tubular heater, including the flexible cable, may be coiled onto a spool before installation into a heater well. In an embodiment, the temperature limited heater is installed using the coiled tubing rig. The coiled tubing rig may place the temperature limited heater in a deformation resistant container in the formation. The deformation resistant container may be placed in the heater well using conventional methods.

[0539] Temperature limited heaters may be used for heating hydrocarbon formations including, but not limited to, oil shale formations, coal formations, tar sands formations, and formations with heavy viscous oils. Temperature limited heaters may also be used in the field of environmental remediation to vaporize or destroy soil contaminants. Embodiments of temperature limited heaters may be used to heat fluids in a wellbore or sub-sea pipeline to inhibit deposition of paraffin or various hydrates. In some embodiments, a temperature limited heater is used for solution mining a subsurface formation (for example, an oil shale or a coal formation). In certain embodiments, a fluid (for example, molten salt) is placed in a wellbore and heated with a temperature limited heater to inhibit deformation and/or collapse of the wellbore. In some embodiments, the temperature limited heater is attached to a sucker rod in the wellbore or is part of the sucker rod itself. In some embodiments, temperature limited heaters are used to heat a near wellbore region to reduce near wellbore oil viscosity during production of high viscosity crude oils and during transport of high viscosity oils to the surface. In some embodiments, a temperature limited heater enables gas lifting of a viscous oil by lowering the viscosity of the oil without coking the oil. Temperature limited heaters may be used in sulfur transfer lines to maintain temperatures between about 110° C. and about 130° C.

[0540] The ferromagnetic alloy or ferromagnetic alloys used in the temperature limited heater determine the Curie temperature of the heater. Curie temperature data for various metals is listed in "American Institute of Physics Handbook," Second Edition, McGraw-Hill, pages 5-170 through 5-176. Ferromagnetic conductors may include one or more of the ferromagnetic elements (iron, cobalt, and nickel) and/or alloys of these elements. In some embodiments, ferromagnetic conductors include iron-chromium (Fe—Cr) alloys that contain tungsten (W) (for example, HCM12A and SAVE12 (Sumitomo Metals Co., Japan)) and/or iron alloys that contain chromium (for example, Fe—Cr alloys, Fe—Cr—W alloys, Fe—Cr—V (vanadium) alloys, and Fe—Cr—Nb (Niobium) alloys). Of the three main ferromagnetic elements, iron has a Curie temperature of approximately 770° C.; cobalt (Co) has a Curie temperature of approximately 1131° C.; and nickel has a Curie temperature of approximately 358° C. An iron-cobalt alloy has a Curie temperature higher than the Curie temperature of iron. For example, iron-cobalt alloy with 2% by weight cobalt has a Curie temperature of approximately 800° C.; iron-cobalt alloy with 12% by weight cobalt has a Curie temperature of approximately 900° C.; and iron-cobalt alloy with 20% by weight cobalt has a Curie temperature of approximately 950° C. Iron-nickel alloy has a Curie temperature lower than the Curie temperature of iron. For example, iron-nickel alloy with 20% by weight nickel has a Curie temperature of approximately 720° C., and iron-nickel alloy with 60% by weight nickel has a Curie temperature of approximately 560° C.

[0541] Some non-ferromagnetic elements used as alloys raise the Curie temperature of iron. For example, an iron-

vanadium alloy with 5.9% by weight vanadium has a Curie temperature of approximately 815° C. Other non-ferromagnetic elements (for example, carbon, aluminum, copper, silicon, and/or chromium) may be alloyed with iron or other ferromagnetic materials to lower the Curie temperature. Non-ferromagnetic materials that raise the Curie temperature may be combined with non-ferromagnetic materials that lower the Curie temperature and alloyed with iron or other ferromagnetic materials to produce a material with a desired Curie temperature and other desired physical and/or chemical properties. In some embodiments, the Curie temperature material is a ferrite such as NiFe_2O_4 . In other embodiments, the Curie temperature material is a binary compound such as FeNi_3 or Fe_3Al .

[0542] In some embodiments, the improved alloy includes carbon, cobalt, iron, manganese, silicon, or mixtures thereof. In certain embodiments, the improved alloy includes, by weight: about 0.1% to about 10% cobalt; about 0.1% carbon, about 0.5% manganese, about 0.5% silicon, with the balance being iron. In certain embodiments, the improved alloy includes, by weight: about 0.1% to about 10% cobalt; about 0.1% carbon, about 0.5% manganese, about 0.5% silicon, with the balance being iron.

[0543] In some embodiments, the improved alloy includes chromium, carbon, cobalt, iron, manganese, silicon, titanium, vanadium, or mixtures thereof. In certain embodiments, the improved alloy includes, by weight: about 5% to about 20% cobalt, about 0.1% carbon, about 0.5% manganese, about 0.5% silicon, about 0.1% to about 2% vanadium with the balance being iron. In some embodiments, the improved alloy includes, by weight: about 12% chromium, about 0.1% carbon, about 0.5% silicon, about 0.1% to about 0.5% manganese, above 0% to about 15% cobalt, above 0% to about 2% vanadium, above 0% to about 1% titanium, with the balance being iron. In some embodiments, the improved alloy includes, by weight: about 12% chromium, about 0.1% carbon, about 0.5% silicon, about 0.1% to about 0.5% manganese, above 0% to about 2% vanadium, above 0% to about 1% titanium, with the balance being iron. In some embodiments, the improved alloy includes, by weight: about 12% chromium, about 0.1% carbon, about 0.5% silicon, about 0.1% to about 0.5% manganese, above 0% to about 15% cobalt, above 0% to about 1% titanium, with the balance being iron. In certain embodiments, the improved alloy includes, by weight: about 12% chromium, about 0.1% carbon, about 0.5% silicon, about 0.1% to about 0.5% manganese, above 0% to about 15% cobalt, above 0% to about 1% titanium, with the balance being iron. The addition of vanadium may allow for use of higher amounts of cobalt in the improved alloy.

[0544] Certain embodiments of temperature limited heaters may include more than one ferromagnetic material. Such embodiments are within the scope of embodiments described herein if any conditions described herein apply to at least one of the ferromagnetic materials in the temperature limited heater.

[0545] Ferromagnetic properties generally decay as the Curie temperature and/or the phase transformation temperature range is approached. The “Handbook of Electrical Heating for Industry” by C. James Erickson (IEEE Press, 1995) shows a typical curve for 1% carbon steel (steel with 1%

carbon by weight). The loss of magnetic permeability starts at temperatures above 650° C. and tends to be complete when temperatures exceed 730° C. Thus, the self-limiting temperature may be somewhat below the actual Curie temperature and/or the phase transformation temperature range of the ferromagnetic conductor. The skin depth for current flow in 1% carbon steel is 0.132 cm at room temperature and increases to 0.445 cm at 720° C. From 720° C. to 730° C., the skin depth sharply increases to over 2.5 cm. Thus, a temperature limited heater embodiment using 1% carbon steel begins to self-limit between 650° C. and 730° C.

[0546] Skin depth generally defines an effective penetration depth of time-varying current into the conductive material. In general, current density decreases exponentially with distance from an outer surface to the center along the radius of the conductor. The depth at which the current density is approximately 1/e of the surface current density is called the skin depth. For a solid cylindrical rod with a diameter much greater than the penetration depth, or for hollow cylinders with a wall thickness exceeding the penetration depth, the skin depth, δ , is:

$$\delta = 1981.5 * (\rho / (\mu * f))^{1/2}; \quad (\text{EQN. 2})$$

in which:

[0547] δ =skin depth in inches;

[0548] ρ =resistivity at operating temperature (ohm-cm);

[0549] μ =relative magnetic permeability; and

[0550] f =frequency (Hz).

EQN. 2 is obtained from “Handbook of Electrical Heating for Industry” by C. James Erickson (IEEE Press, 1995). For most metals, resistivity (ρ) increases with temperature. The relative magnetic permeability generally varies with temperature and with current. Additional equations may be used to assess the variance of magnetic permeability and/or skin depth on both temperature and/or current. The dependence of μ on current arises from the dependence of μ on the electromagnetic field.

[0551] Materials used in the temperature limited heater may be selected to provide a desired turndown ratio. Turndown ratios of at least 1.1:1, 2:1, 3:1, 4:1, 5:1, 10:1, 30:1, or 50:1 may be selected for temperature limited heaters. Larger turndown ratios may also be used. A selected turndown ratio may depend on a number of factors including, but not limited to, the type of formation in which the temperature limited heater is located (for example, a higher turndown ratio may be used for an oil shale formation with large variations in thermal conductivity between rich and lean oil shale layers) and/or a temperature limit of materials used in the wellbore (for example, temperature limits of heater materials). In some embodiments, the turndown ratio is increased by coupling additional copper or another good electrical conductor to the ferromagnetic material (for example, adding copper to lower the resistance above the Curie temperature and/or the phase transformation temperature range).

[0552] The temperature limited heater may provide a maximum heat output (power output) below the Curie temperature and/or the phase transformation temperature range of the heater. In certain embodiments, the maximum heat output is at least 400 W/m (Watts per meter), 600 W/m, 700 W/m, 800 W/m, or higher up to 2000 W/m. The temperature limited heater reduces the amount of heat output by a section of the heater when the temperature of the section of the heater approaches or is above the Curie temperature and/or the phase transformation temperature range. The reduced amount of

heat may be substantially less than the heat output below the Curie temperature and/or the phase transformation temperature range. In some embodiments, the reduced amount of heat is at most 400 W/m, 200 W/m, 100 W/m or may approach 0 W/m.

[0553] In certain embodiments, the temperature limited heater operates substantially independently of the thermal load on the heater in a certain operating temperature range. "Thermal load" is the rate that heat is transferred from a heating system to its surroundings. It is to be understood that the thermal load may vary with temperature of the surroundings and/or the thermal conductivity of the surroundings. In an embodiment, the temperature limited heater operates at or above the Curie temperature and/or the phase transformation temperature range of the temperature limited heater such that the operating temperature of the heater increases at most by 3° C., 2° C., 1.5° C., 1° C., or 0.5° C. for a decrease in thermal load of 1 W/m proximate to a portion of the heater. In certain embodiments, the temperature limited heater operates in such a manner at a relatively constant current.

[0554] The AC or modulated DC resistance and/or the heat output of the temperature limited heater may decrease as the temperature approaches the Curie temperature and/or the phase transformation temperature range and decrease sharply near or above the Curie temperature due to the Curie effect and/or phase transformation effect. In certain embodiments, the value of the electrical resistance or heat output above or near the Curie temperature and/or the phase transformation temperature range is at most one-half of the value of electrical resistance or heat output at a certain point below the Curie temperature and/or the phase transformation temperature range. In some embodiments, the heat output above or near the Curie temperature and/or the phase transformation temperature range is at most 90%, 70%, 50%, 30%, 20%, 10%, or less (down to 1%) of the heat output at a certain point below the Curie temperature and/or the phase transformation temperature range (for example, 30° C. below the Curie temperature, 40° C. below the Curie temperature, 50° C. below the Curie temperature, or 100° C. below the Curie temperature). In certain embodiments, the electrical resistance above or near the Curie temperature and/or the phase transformation temperature range decreases to 80%, 70%, 60%, 50%, or less (down to 1%) of the electrical resistance at a certain point below the Curie temperature and/or the phase transformation temperature range (for example, 30° C. below the Curie temperature, 40° C. below the Curie temperature, 50° C. below the Curie temperature, or 100° C. below the Curie temperature).

[0555] In some embodiments, AC frequency is adjusted to change the skin depth of the ferromagnetic material. For example, the skin depth of 1% carbon steel at room temperature is 0.132 cm at 60 Hz, 0.0762 cm at 180 Hz, and 0.046 cm at 440 Hz. Since heater diameter is typically larger than twice the skin depth, using a higher frequency (and thus a heater with a smaller diameter) reduces heater costs. For a fixed geometry, the higher frequency results in a higher turndown ratio. The turndown ratio at a higher frequency is calculated by multiplying the turndown ratio at a lower frequency by the square root of the higher frequency divided by the lower frequency. In some embodiments, a frequency between 100 Hz and 1000 Hz, between 140 Hz and 200 Hz, or between 400 Hz and 600 Hz is used (for example, 180 Hz, 540 Hz, or 720 Hz). In some embodiments, high frequencies may be used. The frequencies may be greater than 1000 Hz.

[0556] To maintain a substantially constant skin depth until the Curie temperature and/or the phase transformation temperature range of the temperature limited heater is reached, the heater may be operated at a lower frequency when the heater is cold and operated at a higher frequency when the heater is hot. Line frequency heating is generally favorable, however, because there is less need for expensive components such as power supplies, transformers, or current modulators that alter frequency. Line frequency is the frequency of a general supply of current. Line frequency is typically 60 Hz, but may be 50 Hz or another frequency depending on the source for the supply of the current. Higher frequencies may be produced using commercially available equipment such as solid state variable frequency power supplies. Transformers that convert three-phase power to single-phase power with three times the frequency are commercially available. For example, high voltage three-phase power at 60 Hz may be transformed to single-phase power at 180 Hz and at a lower voltage. Such transformers are less expensive and more energy efficient than solid state variable frequency power supplies. In certain embodiments, transformers that convert three-phase power to single-phase power are used to increase the frequency of power supplied to the temperature limited heater.

[0557] In certain embodiments, modulated DC (for example, chopped DC, waveform modulated DC, or cycled DC) may be used for providing electrical power to the temperature limited heater. A DC modulator or DC chopper may be coupled to a DC power supply to provide an output of modulated direct current. In some embodiments, the DC power supply may include means for modulating DC. One example of a DC modulator is a DC-to-DC converter system. DC-to-DC converter systems are generally known in the art. DC is typically modulated or chopped into a desired waveform. Waveforms for DC modulation include, but are not limited to, square-wave, sinusoidal, deformed sinusoidal, deformed square-wave, triangular, and other regular or irregular waveforms.

[0558] The modulated DC waveform generally defines the frequency of the modulated DC. Thus, the modulated DC waveform may be selected to provide a desired modulated DC frequency. The shape and/or the rate of modulation (such as the rate of chopping) of the modulated DC waveform may be varied to vary the modulated DC frequency. DC may be modulated at frequencies that are higher than generally available AC frequencies. For example, modulated DC may be provided at frequencies of at least 1000 Hz. Increasing the frequency of supplied current to higher values advantageously increases the turndown ratio of the temperature limited heater.

[0559] In certain embodiments, the modulated DC waveform is adjusted or altered to vary the modulated DC frequency. The DC modulator may be able to adjust or alter the modulated DC waveform at any time during use of the temperature limited heater and at high currents or voltages. Thus, modulated DC provided to the temperature limited heater is not limited to a single frequency or even a small set of frequency values. Waveform selection using the DC modulator typically allows for a wide range of modulated DC frequencies and for discrete control of the modulated DC frequency. Thus, the modulated DC frequency is more easily set at a distinct value whereas AC frequency is generally limited to multiples of the line frequency. Discrete control of the modulated DC frequency allows for more selective control over the

turndown ratio of the temperature limited heater. Being able to selectively control the turndown ratio of the temperature limited heater allows for a broader range of materials to be used in designing and constructing the temperature limited heater.

[0560] In some embodiments, the modulated DC frequency or the AC frequency is adjusted to compensate for changes in properties (for example, subsurface conditions such as temperature or pressure) of the temperature limited heater during use. The modulated DC frequency or the AC frequency provided to the temperature limited heater is varied based on assessed downhole conditions. For example, as the temperature of the temperature limited heater in the wellbore increases, it may be advantageous to increase the frequency of the current provided to the heater, thus increasing the turndown ratio of the heater. In an embodiment, the downhole temperature of the temperature limited heater in the wellbore is assessed.

[0561] In certain embodiments, the modulated DC frequency, or the AC frequency, is varied to adjust the turndown ratio of the temperature limited heater. The turndown ratio may be adjusted to compensate for hot spots occurring along a length of the temperature limited heater. For example, the turndown ratio is increased because the temperature limited heater is getting too hot in certain locations. In some embodiments, the modulated DC frequency, or the AC frequency, are varied to adjust a turndown ratio without assessing a subsurface condition.

[0562] At or near the Curie temperature and/or the phase transformation temperature range of the ferromagnetic material, a relatively small change in voltage may cause a relatively large change in current to the load. The relatively small change in voltage may produce problems in the power supplied to the temperature limited heater, especially at or near the Curie temperature and/or the phase transformation temperature range. The problems include, but are not limited to, reducing the power factor, tripping a circuit breaker, and/or blowing a fuse. In some cases, voltage changes may be caused by a change in the load of the temperature limited heater. In certain embodiments, an electrical current supply (for example, a supply of modulated DC or AC) provides a relatively constant amount of current that does not substantially vary with changes in load of the temperature limited heater. In an embodiment, the electrical current supply provides an amount of electrical current that remains within 15%, within 10%, within 5%, or within 2% of a selected constant current value when a load of the temperature limited heater changes.

[0563] Temperature limited heaters may generate an inductive load. The inductive load is due to some applied electrical current being used by the ferromagnetic material to generate a magnetic field in addition to generating a resistive heat output. As downhole temperature changes in the temperature limited heater, the inductive load of the heater changes due to changes in the ferromagnetic properties of ferromagnetic materials in the heater with temperature. The inductive load of the temperature limited heater may cause a phase shift between the current and the voltage applied to the heater.

[0564] A reduction in actual power applied to the temperature limited heater may be caused by a time lag in the current waveform (for example, the current has a phase shift relative to the voltage due to an inductive load) and/or by distortions in the current waveform (for example, distortions in the current waveform caused by introduced harmonics due to a non-linear load). Thus, it may take more current to apply a selected

amount of power due to phase shifting or waveform distortion. The ratio of actual power applied and the apparent power that would have been transmitted if the same current were in phase and undistorted is the power factor. The power factor is always less than or equal to 1. The power factor is 1 when there is no phase shift or distortion in the waveform.

[0565] Actual power applied to a heater due to a phase shift may be described by EQN. 3:

$$P=I \times V \times \cos(\theta); \quad (\text{EQN. 3})$$

in which P is the actual power applied to a heater; I is the applied current; V is the applied voltage; and θ is the phase angle difference between voltage and current. Other phenomena such as waveform distortion may contribute to further lowering of the power factor. If there is no distortion in the waveform, then $\cos(\theta)$ is equal to the power factor.

[0566] In certain embodiments, the temperature limited heater includes an inner conductor inside an outer conductor. The inner conductor and the outer conductor are radially disposed about a central axis. The inner and outer conductors may be separated by an insulation layer. In certain embodiments, the inner and outer conductors are coupled at the bottom of the temperature limited heater. Electrical current may flow into the temperature limited heater through the inner conductor and return through the outer conductor. One or both conductors may include ferromagnetic material.

[0567] The insulation layer may include an electrically insulating ceramic with high thermal conductivity, such as magnesium oxide, aluminum oxide, silicon dioxide, beryllium oxide, boron nitride, silicon nitride, or combinations thereof. The insulating layer may be a compacted powder (for example, compacted ceramic powder). Compaction may improve thermal conductivity and provide better insulation resistance. For lower temperature applications, polymer insulation made from, for example, fluoropolymers, polyimides, polyamides, and/or polyethylenes, may be used. In some embodiments, the polymer insulation is made of perfluoroalkoxy (PFA) or polyetheretherketone (PEEK™ (Victrex Ltd, England)). The insulating layer may be chosen to be substantially infrared transparent to aid heat transfer from the inner conductor to the outer conductor. In an embodiment, the insulating layer is transparent quartz sand. The insulation layer may be air or a non-reactive gas such as helium, nitrogen, or sulfur hexafluoride. If the insulation layer is air or a non-reactive gas, there may be insulating spacers designed to inhibit electrical contact between the inner conductor and the outer conductor. The insulating spacers may be made of, for example, high purity aluminum oxide or another thermally conducting, electrically insulating material such as silicon nitride. The insulating spacers may be a fibrous ceramic material such as Nextel™ 312 (3M Corporation, St. Paul, Minn., U.S.A.), mica tape, or glass fiber. Ceramic material may be made of alumina, alumina-silicate, alumina-borosilicate, silicon nitride, boron nitride, or other materials.

[0568] The insulation layer may be flexible and/or substantially deformation tolerant. For example, if the insulation layer is a solid or compacted material that substantially fills the space between the inner and outer conductors, the temperature limited heater may be flexible and/or substantially deformation tolerant. Forces on the outer conductor can be transmitted through the insulation layer to the solid inner conductor, which may resist crushing. Such a temperature limited heater may be bent, dog-legged, and spiraled without causing the outer conductor and the inner conductor to elec-

trically short to each other. Deformation tolerance may be important if the wellbore is likely to undergo substantial deformation during heating of the formation.

[0569] In certain embodiments, an outermost layer of the temperature limited heater (for example, the outer conductor) is chosen for corrosion resistance, yield strength, and/or creep resistance. In one embodiment, austenitic (non-ferromagnetic) stainless steels such as 201, 304H, 347H, 347HH, 316H, 310H, 347HP, NF709 (Nippon Steel Corp., Japan) stainless steels, or combinations thereof may be used in the outer conductor. The outermost layer may also include a clad conductor. For example, a corrosion resistant alloy such as 800H or 347H stainless steel may be clad for corrosion protection over a ferromagnetic carbon steel tubular. If high temperature strength is not required, the outermost layer may be constructed from ferromagnetic metal with good corrosion resistance such as one of the ferritic stainless steels. In one embodiment, a ferritic alloy of 82.3% by weight iron with 17.7% by weight chromium (Curie temperature of 678° C.) provides desired corrosion resistance.

[0570] The Metals Handbook, vol. 8, page 291 (American Society of Materials (ASM)) includes a graph of Curie temperature of iron-chromium alloys versus the amount of chromium in the alloys. In some temperature limited heater embodiments, a separate support rod or tubular (made from 347H stainless steel) is coupled to the temperature limited heater made from an iron-chromium alloy to provide yield strength and/or creep resistance. In certain embodiments, the support material and/or the ferromagnetic material is selected to provide a 100,000 hour creep-rupture strength of at least 20.7 MPa at 650° C. In some embodiments, the 100,000 hour creep-rupture strength is at least 13.8 MPa at 650° C. or at least 6.9 MPa at 650° C. For example, 347H steel has a favorable creep-rupture strength at or above 650° C. In some embodiments, the 100,000 hour creep-rupture strength ranges from 6.9 MPa to 41.3 MPa or more for longer heaters and/or higher earth or fluid stresses.

[0571] In temperature limited heater embodiments with both an inner ferromagnetic conductor and an outer ferromagnetic conductor, the skin effect current path occurs on the outside of the inner conductor and on the inside of the outer conductor. Thus, the outside of the outer conductor may be clad with the corrosion resistant alloy, such as stainless steel, without affecting the skin effect current path on the inside of the outer conductor.

[0572] A ferromagnetic conductor with a thickness of at least the skin depth at the Curie temperature and/or the phase transformation temperature range allows a substantial decrease in resistance of the ferromagnetic material as the skin depth increases sharply near the Curie temperature and/or the phase transformation temperature range. In certain embodiments when the ferromagnetic conductor is not clad with a highly conducting material such as copper, the thickness of the conductor may be 1.5 times the skin depth near the Curie temperature and/or the phase transformation temperature range, 3 times the skin depth near the Curie temperature and/or the phase transformation temperature range, or even 10 or more times the skin depth near the Curie temperature and/or the phase transformation temperature range. If the ferromagnetic conductor is clad with copper, thickness of the ferromagnetic conductor may be substantially the same as the skin depth near the Curie temperature and/or the phase transformation temperature range. In some embodiments, the ferromagnetic conductor clad with copper has a thickness of at

least three-fourths of the skin depth near the Curie temperature and/or the phase transformation temperature range.

[0573] In certain embodiments, the temperature limited heater includes a composite conductor with a ferromagnetic tubular and a non-ferromagnetic, high electrical conductivity core. The non-ferromagnetic, high electrical conductivity core reduces a required diameter of the conductor. For example, the conductor may be composite 1.19 cm diameter conductor with a core of 0.575 cm diameter copper clad with a 0.298 cm thickness of ferritic stainless steel or carbon steel surrounding the core. The core or non-ferromagnetic conductor may be copper or copper alloy. The core or non-ferromagnetic conductor may also be made of other metals that exhibit low electrical resistivity and relative magnetic permeabilities near 1 (for example, substantially non-ferromagnetic materials such as aluminum and aluminum alloys, phosphor bronze, beryllium copper, and/or brass). A composite conductor allows the electrical resistance of the temperature limited heater to decrease more steeply near the Curie temperature and/or the phase transformation temperature range. As the skin depth increases near the Curie temperature and/or the phase transformation temperature range to include the copper core, the electrical resistance decreases very sharply.

[0574] The composite conductor may increase the conductivity of the temperature limited heater and/or allow the heater to operate at lower voltages. In an embodiment, the composite conductor exhibits a relatively flat resistance versus temperature profile at temperatures below a region near the Curie temperature and/or the phase transformation temperature range of the ferromagnetic conductor of the composite conductor. In some embodiments, the temperature limited heater exhibits a relatively flat resistance versus temperature profile between 100° C. and 750° C. or between 300° C. and 600° C. The relatively flat resistance versus temperature profile may also be exhibited in other temperature ranges by adjusting, for example, materials and/or the configuration of materials in the temperature limited heater. In certain embodiments, the relative thickness of each material in the composite conductor is selected to produce a desired resistivity versus temperature profile for the temperature limited heater.

[0575] In certain embodiments, the relative thickness of each material in a composite conductor is selected to produce a desired resistivity versus temperature profile for a temperature limited heater. In an embodiment, the composite conductor is an inner conductor surrounded by 0.127 cm thick magnesium oxide powder as an insulator. The outer conductor may be 304H stainless steel with a wall thickness of 0.127 cm. The outside diameter of the heater may be about 1.65 cm.

[0576] A composite conductor (for example, a composite inner conductor or a composite outer conductor) may be manufactured by methods including, but not limited to, coextrusion, roll forming, tight fit tubing (for example, cooling the inner member and heating the outer member, then inserting the inner member in the outer member, followed by a drawing operation and/or allowing the system to cool), explosive or electromagnetic cladding, arc overlay welding, longitudinal strip welding, plasma powder welding, billet coextrusion, electroplating, drawing, sputtering, plasma deposition, coextrusion casting, magnetic forming, molten cylinder casting (of inner core material inside the outer or vice versa), insertion followed by welding or high temperature braising, shielded active gas welding (SAG), and/or insertion of an inner pipe in an outer pipe followed by mechanical expansion of the inner pipe by hydroforming or use of a pig to expand

and swage the inner pipe against the outer pipe. In some embodiments, a ferromagnetic conductor is braided over a non-ferromagnetic conductor. In certain embodiments, composite conductors are formed using methods similar to those used for cladding (for example, cladding copper to steel). A metallurgical bond between copper cladding and base ferromagnetic material may be advantageous. Composite conductors produced by a coextrusion process that forms a good metallurgical bond (for example, a good bond between copper and 446 stainless steel) may be provided by Anomet Products, Inc. (Shrewsbury, Mass., U.S.A.).

[0577] In certain embodiments, it may be desirable to form a composite conductor by various methods including longitudinal strip welding. In some embodiments, however, it may be difficult to use longitudinal strip welding techniques if the desired thickness of a layer of a first material has such a large thickness, in relation to the inner core/layer onto which such layer is to be bended, that it does not effectively and/or efficiently bend around an inner core or layer that is made of a second material. In such circumstances, it may be beneficial to use multiple thinner layers of the first material in the longitudinal strip welding process such that the multiple thinner layers can more readily be employed in a longitudinal strip welding process and coupled together to form a composite of the first material with the desired thickness. So, for example, a first layer of the first material may be bent around an inner core or layer of second material, and then a second layer of the first material may be bent around the first layer of the first material, with the thicknesses of the first and second layers being such that the first and second layers will readily bend around the inner core or layer in a longitudinal strip welding process. Thus, the two layers of the first material may together form the total desired thickness of the first material.

[0578] FIGS. 15-32 depict various embodiments of temperature limited heaters. One or more features of an embodiment of the temperature limited heater depicted in any of these figures may be combined with one or more features of other embodiments of temperature limited heaters depicted in these figures. In certain embodiments described herein, temperature limited heaters are dimensioned to operate at a frequency of 60 Hz AC. It is to be understood that dimensions of the temperature limited heater may be adjusted from those described herein to operate in a similar manner at other AC frequencies or with modulated DC current.

[0579] The temperature limited heaters may be used in conductor-in-conduit heaters. In some embodiments of conductor-in-conduit heaters, the majority of the resistive heat is generated in the conductor, and the heat radiatively, conductively and/or convectively transfers to the conduit. In some embodiments of conductor-in-conduit heaters, the majority of the resistive heat is generated in the conduit.

[0580] FIG. 15 depicts a cross-sectional representation of an embodiment of the temperature limited heater with an outer conductor having a ferromagnetic section and a non-ferromagnetic section. FIGS. 16 and 17 depict transverse cross-sectional views of the embodiment shown in FIG. 15. In one embodiment, ferromagnetic section 358 is used to provide heat to hydrocarbon layers in the formation. Non-ferromagnetic section 360 is used in the overburden of the formation. Non-ferromagnetic section 360 provides little or no heat to the overburden, thus inhibiting heat losses in the overburden and improving heater efficiency. Ferromagnetic section 358 includes a ferromagnetic material such as 409 stainless steel or 410 stainless steel. Ferromagnetic section 358 has a

thickness of 0.3 cm. Non-ferromagnetic section 360 is copper with a thickness of 0.3 cm. Inner conductor 362 is copper. Inner conductor 362 has a diameter of 0.9 cm. Electrical insulator 364 is silicon nitride, boron nitride, magnesium oxide powder, or another suitable insulator material. Electrical insulator 364 has a thickness of 0.1 cm to 0.3 cm.

[0581] FIG. 18 depicts a cross-sectional representation of an embodiment of a temperature limited heater with an outer conductor having a ferromagnetic section and a non-ferromagnetic section placed inside a sheath. FIGS. 19, 20, and 21 depict transverse cross-sectional views of the embodiment shown in FIG. 18. Ferromagnetic section 358 is 410 stainless steel with a thickness of 0.6 cm. Non-ferromagnetic section 360 is copper with a thickness of 0.6 cm. Inner conductor 362 is copper with a diameter of 0.9 cm. Outer conductor 366 includes ferromagnetic material. Outer conductor 366 provides some heat in the overburden section of the heater. Providing some heat in the overburden inhibits condensation or refluxing of fluids in the overburden. Outer conductor 366 is 409, 410, or 446 stainless steel with an outer diameter of 3.0 cm and a thickness of 0.6 cm. Electrical insulator 364 includes compacted magnesium oxide powder with a thickness of 0.3 cm. In some embodiments, electrical insulator 364 includes silicon nitride, boron nitride, or hexagonal type boron nitride. Conductive section 368 may couple inner conductor 362 with ferromagnetic section 358 and/or outer conductor 366.

[0582] FIG. 22A and FIG. 22B depict cross-sectional representations of an embodiment of a temperature limited heater with a ferromagnetic outer conductor. The outer conductor is clad with a conductive layer and a corrosion resistant alloy. Inner conductor 362 is copper. Electrical insulator 364 is silicon nitride, boron nitride, or magnesium oxide. Outer conductor 366 is a 1" Schedule 80 446 stainless steel pipe. Outer conductor 366 is coupled to jacket 370. Jacket 370 is made from corrosion resistant material such as 347H stainless steel. In an embodiment, conductive layer 372 is placed between outer conductor 366 and jacket 370. Conductive layer 372 is a copper layer. Heat is produced primarily in outer conductor 366, resulting in a small temperature differential across electrical insulator 364. Conductive layer 372 allows a sharp decrease in the resistance of outer conductor 366 as the outer conductor approaches the Curie temperature and/or the phase transformation temperature range. Jacket 370 provides protection from corrosive fluids in the wellbore.

[0583] In certain embodiments, inner conductor 362 includes a core of copper or another non-ferromagnetic conductor surrounded by ferromagnetic material (for example, a low Curie temperature material such as Invar 36). In certain embodiments, the copper core has an outer diameter between about 0.125" and about 0.375" (for example, about 0.5") and the ferromagnetic material has an outer diameter between about 0.625" and about 1" (for example, about 0.75"). The copper core may increase the turndown ratio of the heater and/or reduce the thickness needed in the ferromagnetic material, which may allow a lower cost heater to be made. Electrical insulator 364 may be magnesium oxide with an outer diameter between about 1" and about 1.2" (for example, about 1.11"). Outer conductor 366 may include non-ferromagnetic electrically conductive material with high mechanical strength such as 825 stainless steel. Outer conductor 366 may have an outer diameter between about 1.2" and about 1.5" (for example, about 1.33"). In certain embodiments, inner conductor 362 is a forward current path and outer con-

ductor 366 is a return current path. Conductive layer 372 may include copper or another non-ferromagnetic material with an outer diameter between about 1.3" and about 1.4" (for example, about 1.384"). Conductive layer 372 may decrease the resistance of the return current path (to reduce the heat output of the return path such that little or no heat is generated in the return path) and/or increase the turndown ratio of the heater. Conductive layer 372 may reduce the thickness needed in outer conductor 366 and/or jacket 370, which may allow a lower cost heater to be made. Jacket 370 may include ferromagnetic material such as carbon steel or 410 stainless steel with an outer diameter between about 1.6" and about 1.8" (for example, about 1.684"). Jacket 370 may have a thickness of at least 2 times the skin depth of the ferromagnetic material in the jacket. Jacket 370 may provide protection from corrosive fluids in the wellbore. In some embodiments, inner conductor 362, electrical insulator 364, and outer conductor 366 are formed as composite heater (for example, an insulated conductor heater) and conductive layer 372 and jacket 370 are formed around (for example, wrapped) the composite heater and welded together to form the larger heater embodiment described herein.

[0584] In certain embodiments, jacket 370 includes ferromagnetic material that has a higher Curie temperature than ferromagnetic material in inner conductor 362. Such a temperature limited heater may "contain" current such that the current does not easily flow from the heater to the surrounding formation and/or to any surrounding fluids (for example, production fluids, formation fluids, brine, groundwater, or formation water). In this embodiment, a majority of the current flows through inner conductor 362 until the Curie temperature of the ferromagnetic material in the inner conductor is reached. After the Curie temperature of ferromagnetic material in inner conductor 362 is reached, a majority of the current flows through the core of copper in the inner conductor. The ferromagnetic properties of jacket 370 inhibit the current from flowing outside the jacket and "contain" the current. Such a heater may be used in lower temperature applications where fluids are present such as providing heat in a production wellbore to increase oil production.

[0585] In some embodiments, the conductor (for example, an inner conductor, an outer conductor, or a ferromagnetic conductor) is the composite conductor that includes two or more different materials. In certain embodiments, the composite conductor includes two or more ferromagnetic materials. In some embodiments, the composite ferromagnetic conductor includes two or more radially disposed materials. In certain embodiments, the composite conductor includes a ferromagnetic conductor and a non-ferromagnetic conductor. In some embodiments, the composite conductor includes the ferromagnetic conductor placed over a non-ferromagnetic core. Two or more materials may be used to obtain a relatively flat electrical resistivity versus temperature profile in a temperature region below the Curie temperature, and/or the phase transformation temperature range, and/or a sharp decrease (a high turndown ratio) in the electrical resistivity at or near the Curie temperature and/or the phase transformation temperature range. In some cases, two or more materials are used to provide more than one Curie temperature and/or phase transformation temperature range for the temperature limited heater.

[0586] The composite electrical conductor may be used as the conductor in any electrical heater embodiment described herein. For example, the composite conductor may be used as

the conductor in a conductor-in-conduit heater or an insulated conductor heater. In certain embodiments, the composite conductor may be coupled to a support member such as a support conductor. The support member may be used to provide support to the composite conductor so that the composite conductor is not relied upon for strength at or near the Curie temperature and/or the phase transformation temperature range. The support member may be useful for heaters of lengths of at least 100 m. The support member may be a non-ferromagnetic member that has good high temperature creep strength. Examples of materials that are used for a support member include, but are not limited to, Haynes® 625 alloy and Haynes® HR120® alloy (Haynes International, Kokomo, Ind., U.S.A.), NF709, Incoloy® 800H alloy and 347HP alloy (Allegheny Ludlum Corp., Pittsburgh, Pa., U.S.A.). In some embodiments, materials in a composite conductor are directly coupled (for example, brazed, metallurgically bonded, or swaged) to each other and/or the support member. Using a support member may reduce the need for the ferromagnetic member to provide support for the temperature limited heater, especially at or near the Curie temperature and/or the phase transformation temperature range. Thus, the temperature limited heater may be designed with more flexibility in the selection of ferromagnetic materials.

[0587] FIG. 23 depicts a cross-sectional representation of an embodiment of the composite conductor with the support member. Core 374 is surrounded by ferromagnetic conductor 376 and support member 378. In some embodiments, core 374, ferromagnetic conductor 376, and support member 378 are directly coupled (for example, brazed together or metallurgically bonded together). In one embodiment, core 374 is copper, ferromagnetic conductor 376 is 446 stainless steel, and support member 378 is 347H alloy. In certain embodiments, support member 378 is a Schedule 80 pipe. Support member 378 surrounds the composite conductor having ferromagnetic conductor 376 and core 374. Ferromagnetic conductor 376 and core 374 may be joined to form the composite conductor by, for example, a coextrusion process. For example, the composite conductor is a 1.9 cm outside diameter 446 stainless steel ferromagnetic conductor surrounding a 0.95 cm diameter copper core.

[0588] In certain embodiments, the diameter of core 374 is adjusted relative to a constant outside diameter of ferromagnetic conductor 376 to adjust the turndown ratio of the temperature limited heater. For example, the diameter of core 374 may be increased to 1.14 cm while maintaining the outside diameter of ferromagnetic conductor 376 at 1.9 cm to increase the turndown ratio of the heater.

[0589] FIG. 24 depicts a cross-sectional representation of an embodiment of the composite conductor with support member 378 separating the conductors. In one embodiment, core 374 is copper with a diameter of 0.95 cm, support member 378 is 347H alloy with an outside diameter of 1.9 cm, and ferromagnetic conductor 376 is 446 stainless steel with an outside diameter of 2.7 cm. The support member depicted in FIG. 24 has a lower creep strength relative to the support members depicted in FIG. 23.

[0590] In certain embodiments, support member 378 is located inside the composite conductor. FIG. 25 depicts a cross-sectional representation of an embodiment of the composite conductor surrounding support member 378. Support member 378 is made of 347H alloy. Inner conductor 362 is copper. Ferromagnetic conductor 376 is 446 stainless steel. In one embodiment, support member 378 is 1.25 cm diameter

347H alloy, inner conductor **362** is 1.9 cm outside diameter copper, and ferromagnetic conductor **376** is 2.7 cm outside diameter 446 stainless steel. The turndown ratio is higher than the turndown ratio for the embodiments depicted in FIGS. **23**, **24**, and **26** for the same outside diameter, but the creep strength is lower.

[0591] In some embodiments, the thickness of inner conductor **362**, which is copper, is reduced and the thickness of support member **378** is increased to increase the creep strength at the expense of reduced turndown ratio. For example, the diameter of support member **378** is increased to 1.6 cm while maintaining the outside diameter of inner conductor **362** at 1.9 cm to reduce the thickness of the conduit. This reduction in thickness of inner conductor **362** results in a decreased turndown ratio relative to the thicker inner conductor embodiment but an increased creep strength.

[0592] FIG. **26** depicts a cross-sectional representation of an embodiment of the composite conductor surrounding support member **378**. In one embodiment, support member **378** is 347H alloy with a 0.63 cm diameter center hole. In some embodiments, support member **378** is a preformed conduit. In certain embodiments, support member **378** is formed by having a dissolvable material (for example, copper dissolvable by nitric acid) located inside the support member during formation of the composite conductor. The dissolvable material is dissolved to form the hole after the conductor is assembled. In an embodiment, support member **378** is 347H alloy with an inside diameter of 0.63 cm and an outside diameter of 1.6 cm, inner conductor **362** is copper with an outside diameter of 1.8 cm, and ferromagnetic conductor **376** is 446 stainless steel with an outside diameter of 2.7 cm.

[0593] In certain embodiments, the composite electrical conductor is used as the conductor in the conductor-in-conduit heater. For example, the composite electrical conductor may be used as conductor **380** in FIG. **27**.

[0594] FIG. **27** depicts a cross-sectional representation of an embodiment of the conductor-in-conduit heater. Conductor **380** is disposed in conduit **382**. Conductor **380** is a rod or conduit of electrically conductive material. Low resistance sections **384** are present at both ends of conductor **380** to generate less heating in these sections. Low resistance section **384** is formed by having a greater cross-sectional area of conductor **380** in that section, or the sections are made of material having less resistance. In certain embodiments, low resistance section **384** includes a low resistance conductor coupled to conductor **380**.

[0595] Conduit **382** is made of an electrically conductive material. Conduit **382** is disposed in opening **386** in hydrocarbon layer **388**. Opening **386** has a diameter that accommodates conduit **382**.

[0596] Conductor **380** may be centered in conduit **382** by centralizers **390**. Centralizers **390** electrically isolate conductor **380** from conduit **382**. Centralizers **390** inhibit movement and properly locate conductor **380** in conduit **382**. Centralizers **390** are made of ceramic material or a combination of ceramic and metallic materials. Centralizers **390** inhibit deformation of conductor **380** in conduit **382**. Centralizers **390** are touching or spaced at intervals between approximately 0.1 m (meters) and approximately 3 m or more along conductor **380**.

[0597] A second low resistance section **384** of conductor **380** may couple conductor **380** to wellhead **392**. Electrical current may be applied to conductor **380** from power cable **394** through low resistance section **384** of conductor **380**.

Electrical current passes from conductor **380** through sliding connector **396** to conduit **382**. Conduit **382** may be electrically insulated from overburden casing **398** and from wellhead **392** to return electrical current to power cable **394**. Heat may be generated in conductor **380** and conduit **382**. The generated heat may radiate in conduit **382** and opening **386** to heat at least a portion of hydrocarbon layer **388**.

[0598] Overburden casing **398** may be disposed in overburden **400**. In some embodiments, overburden casing **398** is surrounded by materials (for example, reinforcing material and/or cement) that inhibit heating of overburden **400**. Low resistance section **384** of conductor **380** may be placed in overburden casing **398**. Low resistance section **384** of conductor **380** is made of, for example, carbon steel. Low resistance section **384** of conductor **380** may be centralized in overburden casing **398** using centralizers **390**. Centralizers **390** are spaced at intervals of approximately 6 m to approximately 12 m or, for example, approximately 9 m along low resistance section **384** of conductor **380**. In a heater embodiment, low resistance sections **384** are coupled to conductor **380** by one or more welds. In other heater embodiments, low resistance sections are threaded, threaded and welded, or otherwise coupled to the conductor. Low resistance section **384** generates little or no heat in overburden casing **398**. Packing **402** may be placed between overburden casing **398** and opening **386**. Packing **402** may be used as a cap at the junction of overburden **400** and hydrocarbon layer **388** to allow filling of materials in the annulus between overburden casing **398** and opening **386**. In some embodiments, packing **402** inhibits fluid from flowing from opening **386** to surface **404**.

[0599] FIG. **28** depicts a cross-sectional representation of an embodiment of a removable conductor-in-conduit heat source. Conduit **382** may be placed in opening **386** through overburden **400** such that a gap remains between the conduit and overburden casing **398**. Fluids may be removed from opening **386** through the gap between conduit **382** and overburden casing **398**. Fluids may be removed from the gap through conduit **406**. Conduit **382** and components of the heat source included in the conduit that are coupled to wellhead **392** may be removed from opening **386** as a single unit. The heat source may be removed as a single unit to be repaired, replaced, and/or used in another portion of the formation.

[0600] For a temperature limited heater in which the ferromagnetic conductor provides a majority of the resistive heat output below the Curie temperature and/or the phase transformation temperature range, a majority of the current flows through material with highly non-linear functions of magnetic field (H) versus magnetic induction (B). These non-linear functions may cause strong inductive effects and distortion that lead to decreased power factor in the temperature limited heater at temperatures below the Curie temperature and/or the phase transformation temperature range. These effects may render the electrical power supply to the temperature limited heater difficult to control and may result in additional current flow through surface and/or overburden power supply conductors. Expensive and/or difficult to implement control systems such as variable capacitors or modulated power supplies may be used to compensate for these effects and to control temperature limited heaters where the majority of the resistive heat output is provided by current flow through the ferromagnetic material.

[0601] In certain temperature limited heater embodiments, the ferromagnetic conductor confines a majority of the flow of

electrical current to an electrical conductor coupled to the ferromagnetic conductor when the temperature limited heater is below or near the Curie temperature and/or the phase transformation temperature range of the ferromagnetic conductor. The electrical conductor may be a sheath, jacket, support member, corrosion resistant member, or other electrically resistive member. In some embodiments, the ferromagnetic conductor confines a majority of the flow of electrical current to the electrical conductor positioned between an outermost layer and the ferromagnetic conductor. The ferromagnetic conductor is located in the cross section of the temperature limited heater such that the magnetic properties of the ferromagnetic conductor at or below the Curie temperature and/or the phase transformation temperature range of the ferromagnetic conductor confine the majority of the flow of electrical current to the electrical conductor. The majority of the flow of electrical current is confined to the electrical conductor due to the skin effect of the ferromagnetic conductor. Thus, the majority of the current is flowing through material with substantially linear resistive properties throughout most of the operating range of the heater.

[0602] In certain embodiments, the ferromagnetic conductor and the electrical conductor are located in the cross section of the temperature limited heater so that the skin effect of the ferromagnetic material limits the penetration depth of electrical current in the electrical conductor and the ferromagnetic conductor at temperatures below the Curie temperature and/or the phase transformation temperature range of the ferromagnetic conductor. Thus, the electrical conductor provides a majority of the electrically resistive heat output of the temperature limited heater at temperatures up to a temperature at or near the Curie temperature and/or the phase transformation temperature range of the ferromagnetic conductor. In certain embodiments, the dimensions of the electrical conductor may be chosen to provide desired heat output characteristics.

[0603] Because the majority of the current flows through the electrical conductor below the Curie temperature and/or the phase transformation temperature range, the temperature limited heater has a resistance versus temperature profile that at least partially reflects the resistance versus temperature profile of the material in the electrical conductor. Thus, the resistance versus temperature profile of the temperature limited heater is substantially linear below the Curie temperature and/or the phase transformation temperature range of the ferromagnetic conductor if the material in the electrical conductor has a substantially linear resistance versus temperature profile. The resistance of the temperature limited heater has little or no dependence on the current flowing through the heater until the temperature nears the Curie temperature and/or the phase transformation temperature range. The majority of the current flows in the electrical conductor rather than the ferromagnetic conductor below the Curie temperature and/or the phase transformation temperature range.

[0604] Resistance versus temperature profiles for temperature limited heaters in which the majority of the current flows in the electrical conductor also tend to exhibit sharper reductions in resistance near or at the Curie temperature and/or the phase transformation temperature range of the ferromagnetic conductor. The sharper reductions in resistance near or at the Curie temperature and/or the phase transformation temperature range are easier to control than more gradual resistance reductions near the Curie temperature and/or the phase trans-

formation temperature range because little current is flowing through the ferromagnetic material.

[0605] In certain embodiments, the material and/or the dimensions of the material in the electrical conductor are selected so that the temperature limited heater has a desired resistance versus temperature profile below the Curie temperature and/or the phase transformation temperature range of the ferromagnetic conductor.

[0606] Temperature limited heaters in which the majority of the current flows in the electrical conductor rather than the ferromagnetic conductor below the Curie temperature and/or the phase transformation temperature range are easier to predict and/or control. Behavior of temperature limited heaters in which the majority of the current flows in the electrical conductor rather than the ferromagnetic conductor below the Curie temperature and/or the phase transformation temperature range may be predicted by, for example, the resistance versus temperature profile and/or the power factor versus temperature profile. Resistance versus temperature profiles and/or power factor versus temperature profiles may be assessed or predicted by, for example, experimental measurements that assess the behavior of the temperature limited heater, analytical equations that assess or predict the behavior of the temperature limited heater, and/or simulations that assess or predict the behavior of the temperature limited heater.

[0607] In certain embodiments, assessed or predicted behavior of the temperature limited heater is used to control the temperature limited heater. The temperature limited heater may be controlled based on measurements (assessments) of the resistance and/or the power factor during operation of the heater. In some embodiments, the power, or current, supplied to the temperature limited heater is controlled based on assessment of the resistance and/or the power factor of the heater during operation of the heater and the comparison of this assessment versus the predicted behavior of the heater. In certain embodiments, the temperature limited heater is controlled without measurement of the temperature of the heater or a temperature near the heater. Controlling the temperature limited heater without temperature measurement eliminates operating costs associated with downhole temperature measurement. Controlling the temperature limited heater based on assessment of the resistance and/or the power factor of the heater also reduces the time for making adjustments in the power or current supplied to the heater compared to controlling the heater based on measured temperature.

[0608] As the temperature of the temperature limited heater approaches or exceeds the Curie temperature and/or the phase transformation temperature range of the ferromagnetic conductor, reduction in the ferromagnetic properties of the ferromagnetic conductor allows electrical current to flow through a greater portion of the electrically conducting cross section of the temperature limited heater. Thus, the electrical resistance of the temperature limited heater is reduced and the temperature limited heater automatically provides reduced heat output at or near the Curie temperature and/or the phase transformation temperature range of the ferromagnetic conductor. In certain embodiments, a highly electrically conductive member is coupled to the ferromagnetic conductor and the electrical conductor to reduce the electrical resistance of the temperature limited heater at or above the Curie temperature and/or the phase transformation temperature range of the ferromagnetic conductor. The highly electrically conductive

member may be an inner conductor, a core, or another conductive member of copper, aluminum, nickel, or alloys thereof.

[0609] The ferromagnetic conductor that confines the majority of the flow of electrical current to the electrical conductor at temperatures below the Curie temperature and/or the phase transformation temperature range may have a relatively small cross section compared to the ferromagnetic conductor in temperature limited heaters that use the ferromagnetic conductor to provide the majority of resistive heat output up to or near the Curie temperature and/or the phase transformation temperature range. A temperature limited heater that uses the electrical conductor to provide a majority of the resistive heat output below the Curie temperature and/or the phase transformation temperature range has low magnetic inductance at temperatures below the Curie temperature and/or the phase transformation temperature range because less current is flowing through the ferromagnetic conductor as compared to the temperature limited heater where the majority of the resistive heat output below the Curie temperature and/or the phase transformation temperature range is provided by the ferromagnetic material. Magnetic field (H) at radius (r) of the ferromagnetic conductor is proportional to the current (I) flowing through the ferromagnetic conductor and the core divided by the radius, or:

$$H \propto I/r. \tag{EQN. 4}$$

Since only a portion of the current flows through the ferromagnetic conductor for a temperature limited heater that uses the outer conductor to provide a majority of the resistive heat output below the Curie temperature and/or the phase transformation temperature range, the magnetic field of the temperature limited heater may be significantly smaller than the magnetic field of the temperature limited heater where the majority of the current flows through the ferromagnetic material. The relative magnetic permeability (μ) may be large for small magnetic fields.

[0610] The skin depth (δ) of the ferromagnetic conductor is inversely proportional to the square root of the relative magnetic permeability (μ):

$$\delta \propto (1/\mu)^{1/2}. \tag{EQN. 5}$$

Increasing the relative magnetic permeability decreases the skin depth of the ferromagnetic conductor. However, because only a portion of the current flows through the ferromagnetic conductor for temperatures below the Curie temperature and/or the phase transformation temperature range, the radius (or thickness) of the ferromagnetic conductor may be decreased for ferromagnetic materials with large relative magnetic permeabilities to compensate for the decreased skin depth while still allowing the skin effect to limit the penetration depth of the electrical current to the electrical conductor at temperatures below the Curie temperature and/or the phase transformation temperature range of the ferromagnetic conductor. The radius (thickness) of the ferromagnetic conductor may be between 0.3 mm and 8 mm, between 0.3 mm and 2 mm, or between 2 mm and 4 mm depending on the relative magnetic permeability of the ferromagnetic conductor. Decreasing the thickness of the ferromagnetic conductor decreases costs of manufacturing the temperature limited heater, as the cost of ferromagnetic material tends to be a significant portion of the cost of the temperature limited heater. Increasing the relative magnetic permeability of the ferromagnetic conductor provides a higher turndown ratio and a sharper decrease in electrical resistance for the temperature limited heater at or near

the Curie temperature and/or the phase transformation temperature range of the ferromagnetic conductor.

[0611] Ferromagnetic materials (such as purified iron or iron-cobalt alloys) with high relative magnetic permeabilities (for example, at least 200, at least 1000, at least 1×10^4 , or at least 1×10^5) and/or high Curie temperatures (for example, at least 600°C ., at least 700°C ., or at least 800°C .) tend to have less corrosion resistance and/or less mechanical strength at high temperatures. The electrical conductor may provide corrosion resistance and/or high mechanical strength at high temperatures for the temperature limited heater. Thus, the ferromagnetic conductor may be chosen primarily for its ferromagnetic properties.

[0612] Confining the majority of the flow of electrical current to the electrical conductor below the Curie temperature and/or the phase transformation temperature range of the ferromagnetic conductor reduces variations in the power factor. Because only a portion of the electrical current flows through the ferromagnetic conductor below the Curie temperature and/or the phase transformation temperature range, the non-linear ferromagnetic properties of the ferromagnetic conductor have little or no effect on the power factor of the temperature limited heater, except at or near the Curie temperature and/or the phase transformation temperature range. Even at or near the Curie temperature and/or the phase transformation temperature range, the effect on the power factor is reduced compared to temperature limited heaters in which the ferromagnetic conductor provides a majority of the resistive heat output below the Curie temperature and/or the phase transformation temperature range. Thus, there is less or no need for external compensation (for example, variable capacitors or waveform modification) to adjust for changes in the inductive load of the temperature limited heater to maintain a relatively high power factor.

[0613] In certain embodiments, the temperature limited heater, which confines the majority of the flow of electrical current to the electrical conductor below the Curie temperature and/or the phase transformation temperature range of the ferromagnetic conductor, maintains the power factor above 0.85, above 0.9, or above 0.95 during use of the heater. Any reduction in the power factor occurs only in sections of the temperature limited heater at temperatures near the Curie temperature and/or the phase transformation temperature range. Most sections of the temperature limited heater are typically not at or near the Curie temperature and/or the phase transformation temperature range during use. These sections have a high power factor that approaches 1.0. The power factor for the entire temperature limited heater is maintained above 0.85, above 0.9, or above 0.95 during use of the heater even if some sections of the heater have power factors below 0.85.

[0614] Maintaining high power factors allows for less expensive power supplies and/or control devices such as solid state power supplies or SCRs (silicon controlled rectifiers). These devices may fail to operate properly if the power factor varies by too large an amount because of inductive loads. With the power factors maintained at high values; however, these devices may be used to provide power to the temperature limited heater. Solid state power supplies have the advantage of allowing fine tuning and controlled adjustment of the power supplied to the temperature limited heater.

[0615] In some embodiments, transformers are used to provide power to the temperature limited heater. Multiple voltage taps may be made into the transformer to provide power

to the temperature limited heater. Multiple voltage taps allow the current supplied to switch back and forth between the multiple voltages. This maintains the current within a range bound by the multiple voltage taps.

[0616] The highly electrically conductive member, or inner conductor, increases the turndown ratio of the temperature limited heater. In certain embodiments, thickness of the highly electrically conductive member is increased to increase the turndown ratio of the temperature limited heater. In some embodiments, the thickness of the electrical conductor is reduced to increase the turndown ratio of the temperature limited heater. In certain embodiments, the turndown ratio of the temperature limited heater is between 1.1 and 10, between 2 and 8, or between 3 and 6 (for example, the turndown ratio is at least 1.1, at least 2, or at least 3).

[0617] FIG. 29 depicts an embodiment of a temperature limited heater in which the support member provides a majority of the heat output below the Curie temperature and/or the phase transformation temperature range of the ferromagnetic conductor. Core 374 is an inner conductor of the temperature limited heater. In certain embodiments, core 374 is a highly electrically conductive material such as copper or aluminum. In some embodiments, core 374 is a copper alloy that provides mechanical strength and good electrical conductivity such as a dispersion strengthened copper. In one embodiment, core 374 is Glidcop® (SCM Metal Products, Inc., Research Triangle Park, North Carolina, U.S.A.). Ferromagnetic conductor 376 is a thin layer of ferromagnetic material between electrical conductor 408 and core 374. In certain embodiments, electrical conductor 408 is also support member 378. In certain embodiments, ferromagnetic conductor 376 is iron or an iron alloy. In some embodiments, ferromagnetic conductor 376 includes ferromagnetic material with a high relative magnetic permeability. For example, ferromagnetic conductor 376 may be purified iron such as Armco ingot iron (AK Steel Ltd., United Kingdom). Iron with some impurities typically has a relative magnetic permeability on the order of 400. Purifying the iron by annealing the iron in hydrogen gas (H₂) at 1450° C. increases the relative magnetic permeability of the iron. Increasing the relative magnetic permeability of ferromagnetic conductor 376 allows the thickness of the ferromagnetic conductor to be reduced. For example, the thickness of unpurified iron may be approximately 4.5 mm while the thickness of the purified iron is approximately 0.76 mm.

[0618] In certain embodiments, electrical conductor 408 provides support for ferromagnetic conductor 376 and the temperature limited heater. Electrical conductor 408 may be made of a material that provides good mechanical strength at temperatures near or above the Curie temperature and/or the phase transformation temperature range of ferromagnetic conductor 376. In certain embodiments, electrical conductor 408 is a corrosion resistant member. Electrical conductor 408 (support member 378) may provide support for ferromagnetic conductor 376 and corrosion resistance. Electrical conductor 408 is made from a material that provides desired electrically resistive heat output at temperatures up to and/or above the Curie temperature and/or the phase transformation temperature range of ferromagnetic conductor 376.

[0619] In an embodiment, electrical conductor 408 is 347H stainless steel. In some embodiments, electrical conductor 408 is another electrically conductive, good mechanical strength, corrosion resistant material. For example, electrical conductor 408 may be 304H, 316H, 347HH, NF709,

Incoloy® 800H alloy (Inco Alloys International, Huntington, W. Va., U.S.A.), Haynes® HR120® alloy, or Inconel® 617 alloy.

[0620] In some embodiments, electrical conductor 408 (support member 378) includes different alloys in different portions of the temperature limited heater. For example, a lower portion of electrical conductor 408 (support member 378) is 347H stainless steel and an upper portion of the electrical conductor (support member) is NF709. In certain embodiments, different alloys are used in different portions of the electrical conductor (support member) to increase the mechanical strength of the electrical conductor (support member) while maintaining desired heating properties for the temperature limited heater.

[0621] In some embodiments, ferromagnetic conductor 376 includes different ferromagnetic conductors in different portions of the temperature limited heater. Different ferromagnetic conductors may be used in different portions of the temperature limited heater to vary the Curie temperature and/or the phase transformation temperature range and, thus, the maximum operating temperature in the different portions. In some embodiments, the Curie temperature and/or the phase transformation temperature range in an upper portion of the temperature limited heater is lower than the Curie temperature and/or the phase transformation temperature range in a lower portion of the heater. The lower Curie temperature and/or the phase transformation temperature range in the upper portion increases the creep-rupture strength lifetime in the upper portion of the heater.

[0622] In the embodiment depicted in FIG. 29, ferromagnetic conductor 376, electrical conductor 408, and core 374 are dimensioned so that the skin depth of the ferromagnetic conductor limits the penetration depth of the majority of the flow of electrical current to the support member when the temperature is below the Curie temperature and/or the phase transformation temperature range of the ferromagnetic conductor. Thus, electrical conductor 408 provides a majority of the electrically resistive heat output of the temperature limited heater at temperatures up to a temperature at or near the Curie temperature and/or the phase transformation temperature range of ferromagnetic conductor 376. In certain embodiments, the temperature limited heater depicted in FIG. 29 is smaller (for example, an outside diameter of 3 cm, 2.9 cm, 2.5 cm, or less) than other temperature limited heaters that do not use electrical conductor 408 to provide the majority of electrically resistive heat output. The temperature limited heater depicted in FIG. 29 may be smaller because ferromagnetic conductor 376 is thin as compared to the size of the ferromagnetic conductor needed for a temperature limited heater in which the majority of the resistive heat output is provided by the ferromagnetic conductor.

[0623] In some embodiments, the support member and the corrosion resistant member are different members in the temperature limited heater. FIGS. 30 and 31 depict embodiments of temperature limited heaters in which the jacket provides a majority of the heat output below the Curie temperature and/or the phase transformation temperature range of the ferromagnetic conductor. In these embodiments, electrical conductor 408 is jacket 370. Electrical conductor 408, ferromagnetic conductor 376, support member 378, and core 374 (in FIG. 30) or inner conductor 362 (in FIG. 31) are dimensioned so that the skin depth of the ferromagnetic conductor limits the penetration depth of the majority of the flow of electrical current to the thickness of the jacket. In certain

embodiments, electrical conductor **408** is a material that is corrosion resistant and provides electrically resistive heat output below the Curie temperature and/or the phase transformation temperature range of ferromagnetic conductor **376**. For example, electrical conductor **408** is 825 stainless steel or 347H stainless steel. In some embodiments, electrical conductor **408** has a small thickness (for example, on the order of 0.5 mm).

[0624] In FIG. 30, core **374** is highly electrically conductive material such as copper or aluminum. Support member **378** is 347H stainless steel or another material with good mechanical strength at or near the Curie temperature and/or the phase transformation temperature range of ferromagnetic conductor **376**.

[0625] In FIG. 31, support member **378** is the core of the temperature limited heater and is 347H stainless steel or another material with good mechanical strength at or near the Curie temperature and/or the phase transformation temperature range of ferromagnetic conductor **376**. Inner conductor **362** is highly electrically conductive material such as copper or aluminum.

[0626] In some embodiments, a relatively thin conductive layer is used to provide the majority of the electrically resistive heat output of the temperature limited heater at temperatures up to a temperature at or near the Curie temperature and/or the phase transformation temperature range of the ferromagnetic conductor. Such a temperature limited heater may be used as the heating member in an insulated conductor heater. The heating member of the insulated conductor heater may be located inside a sheath with an insulation layer between the sheath and the heating member.

[0627] FIGS. 32A and 32B depict cross-sectional representations of an embodiment of the insulated conductor heater with the temperature limited heater as the heating member. Insulated conductor **410** includes core **374**, ferromagnetic conductor **376**, inner conductor **362**, electrical insulator **364**, and jacket **370**. Core **374** is a copper core. Ferromagnetic conductor **376** is, for example, iron or an iron alloy.

[0628] Inner conductor **362** is a relatively thin conductive layer of non-ferromagnetic material with a higher electrical conductivity than ferromagnetic conductor **376**. In certain embodiments, inner conductor **362** is copper. Inner conductor **362** may be a copper alloy. Copper alloys typically have a flatter resistance versus temperature profile than pure copper. A flatter resistance versus temperature profile may provide less variation in the heat output as a function of temperature up to the Curie temperature and/or the phase transformation temperature range. In some embodiments, inner conductor **362** is copper with 6% by weight nickel (for example, CuNi6 or LOHM™). In some embodiments, inner conductor **362** is CuNi10Fe1Mn alloy. Below the Curie temperature and/or the phase transformation temperature range of ferromagnetic conductor **376**, the magnetic properties of the ferromagnetic conductor confine the majority of the flow of electrical current to inner conductor **362**. Thus, inner conductor **362** provides the majority of the resistive heat output of insulated conductor **410** below the Curie temperature and/or the phase transformation temperature range.

[0629] In certain embodiments, inner conductor **362** is dimensioned, along with core **374** and ferromagnetic conductor **376**, so that the inner conductor provides a desired amount of heat output and a desired turndown ratio. For example, inner conductor **362** may have a cross-sectional area that is around 2 or 3 times less than the cross-sectional area of core

374. Typically, inner conductor **362** has to have a relatively small cross-sectional area to provide a desired heat output if the inner conductor is copper or copper alloy. In an embodiment with copper inner conductor **362**, core **374** has a diameter of 0.66 cm, ferromagnetic conductor **376** has an outside diameter of 0.91 cm, inner conductor **362** has an outside diameter of 1.03 cm, electrical insulator **364** has an outside diameter of 1.53 cm, and jacket **370** has an outside diameter of 1.79 cm. In an embodiment with a CuNi6 inner conductor **362**, core **374** has a diameter of 0.66 cm, ferromagnetic conductor **376** has an outside diameter of 0.91 cm, inner conductor **362** has an outside diameter of 1.12 cm, electrical insulator **364** has an outside diameter of 1.63 cm, and jacket **370** has an outside diameter of 1.88 cm. Such insulated conductors are typically smaller and cheaper to manufacture than insulated conductors that do not use the thin inner conductor to provide the majority of heat output below the Curie temperature and/or the phase transformation temperature range.

[0630] Electrical insulator **364** may be magnesium oxide, aluminum oxide, silicon dioxide, beryllium oxide, boron nitride, silicon nitride, or combinations thereof. In certain embodiments, electrical insulator **364** is a compacted powder of magnesium oxide. In some embodiments, electrical insulator **364** includes beads of silicon nitride.

[0631] In certain embodiments, a small layer of material is placed between electrical insulator **364** and inner conductor **362** to inhibit copper from migrating into the electrical insulator at higher temperatures. For example, a small layer of nickel (for example, about 0.5 mm of nickel) may be placed between electrical insulator **364** and inner conductor **362**.

[0632] Jacket **370** is made of a corrosion resistant material such as, but not limited to, 347 stainless steel, 347H stainless steel, 446 stainless steel, or 825 stainless steel. In some embodiments, jacket **370** provides some mechanical strength for insulated conductor **410** at or above the Curie temperature and/or the phase transformation temperature range of ferromagnetic conductor **376**. In certain embodiments, jacket **370** is not used to conduct electrical current.

[0633] For long vertical temperature limited heaters (for example, heaters at least 300 m, at least 500 m, or at least 1 km in length), the hanging stress becomes important in the selection of materials for the temperature limited heater. Without the proper selection of material, the support member may not have sufficient mechanical strength (for example, creep-rupture strength) to support the weight of the temperature limited heater at the operating temperatures of the heater.

[0634] In certain embodiments, materials for the support member are varied to increase the maximum allowable hanging stress at operating temperatures of the temperature limited heater and, thus, increase the maximum operating temperature of the temperature limited heater. Altering the materials of the support member affects the heat output of the temperature limited heater below the Curie temperature and/or the phase transformation temperature range because changing the materials changes the resistance versus temperature profile of the support member. In certain embodiments, the support member is made of more than one material along the length of the heater so that the temperature limited heater maintains desired operating properties (for example, resistance versus temperature profile below the Curie temperature and/or the phase transformation temperature range) as much as possible while providing sufficient mechanical properties to support the heater. In some embodiments, transition sections are used between sections of the heater to

provide strength that compensates for the difference in temperature between sections of the heater. In certain embodiments, one or more portions of the temperature limited heater have varying outside diameters and/or materials to provide desired properties for the heater.

[0635] In certain embodiments of temperature limited heaters, three temperature limited heaters are coupled together in a three-phase wye configuration. Coupling three temperature limited heaters together in the three-phase wye configuration lowers the current in each of the individual temperature limited heaters because the current is split between the three individual heaters. Lowering the current in each individual temperature limited heater allows each heater to have a small diameter. The lower currents allow for higher relative magnetic permeabilities in each of the individual temperature limited heaters and, thus, higher turndown ratios. In addition, there may be no return current path needed for each of the individual temperature limited heaters. Thus, the turndown ratio remains higher for each of the individual temperature limited heaters than if each temperature limited heater had its own return current path.

[0636] In the three-phase wye configuration, individual temperature limited heaters may be coupled together by shorting the sheaths, jackets, or canisters of each of the individual temperature limited heaters to the electrically conductive sections (the conductors providing heat) at their terminating ends (for example, the ends of the heaters at the bottom of a heater wellbore). In some embodiments, the sheaths, jackets, canisters, and/or electrically conductive sections are coupled to a support member that supports the temperature limited heaters in the wellbore.

[0637] In certain embodiments, coupling multiple heaters (for example, mineral insulated conductor heaters) to a single power source, such as a transformer, is advantageous. Coupling multiple heaters to a single transformer may result in using fewer transformers to power heaters used for a treatment area as compared to using individual transformers for each heater. Using fewer transformers reduces surface congestion and allows easier access to the heaters and surface components. Using fewer transformers reduces capital costs associated with providing power to the treatment area. In some embodiments, at least 4, at least 5, at least 10, at least 25 heaters, at least 35 heaters, or at least 45 heaters are powered by a single transformer. Additionally, powering multiple heaters (in different heater wells) from the single transformer may reduce overburden losses because of reduced voltage and/or phase differences between each of the heater wells powered by the single transformer. Powering multiple heaters from the single transformer may inhibit current imbalances between the heaters because the heaters are coupled to the single transformer.

[0638] To provide power to multiple heaters using the single transformer, the transformer may have to provide power at higher voltages to carry the current to each of the heaters effectively. In certain embodiments, the heaters are floating (ungrounded) heaters in the formation. Floating the heaters allows the heaters to operate at higher voltages. In some embodiments, the transformer provides power output of at least about 3 kV, at least about 4 kV, at least about 5 kV, or at least about 6 kV.

[0639] FIG. 33 depicts a top view representation of heater 412 with three insulated conductors 410 in conduit 406. Heater 412 may be located in a heater well in the subsurface formation. Conduit 406 may be a sheath, jacket, or other

enclosure around insulated conductors 410. Each insulated conductor 410 includes core 374, electrical insulator 364, and jacket 370. Insulated conductors 410 may be mineral insulated conductors with core 374 being a copper alloy (for example, a copper-nickel alloy such as Alloy 180), electrical insulator 364 being magnesium oxide, and jacket 370 being Incoloy® 825, copper, or stainless steel (for example 347H stainless steel). In some embodiments, jacket 370 includes non-work hardenable metals so that the jacket is annealable.

[0640] In some embodiments, core 374 and/or jacket 370 include ferromagnetic materials. In some embodiments, one or more insulated conductors 410 are temperature limited heaters. In certain embodiments, the overburden portion of insulated conductors 410 include high electrical conductivity materials in core 374 (for example, pure copper or copper alloys such as copper with 3% silicon at a weld joint) so that the overburden portions of the insulated conductors provide little or no heat output. In certain embodiments, conduit 406 includes non-corrosive materials and/or high strength materials such as stainless steel. In one embodiment, conduit 406 is 347H stainless steel.

[0641] Insulated conductors 410 may be coupled to the single transformer in a three-phase configuration (for example, a three-phase wye configuration). Each insulated conductor 410 may be coupled to one phase of the single transformer. In certain embodiments, the single transformer is also coupled to a plurality of identical heaters 412 in other heater wells in the formation (for example, the single transformer may couple to 40 or more heaters in the formation). In some embodiments, the single transformer couples to at least 4, at least 5, at least 10, at least 15, or at least 25 additional heaters in the formation.

[0642] Electrical insulator 364' may be located inside conduit 406 to electrically insulate insulated conductors 410 from the conduit. In certain embodiments, electrical insulator 364' is magnesium oxide (for example, compacted magnesium oxide). In some embodiments, electrical insulator 364' is silicon nitride (for example, silicon nitride blocks). Electrical insulator 364' electrically insulates insulated conductors 410 from conduit 406 so that at high operating voltages (for example, 3 kV or higher), there is no arcing between the conductors and the conduit. In some embodiments, electrical insulator 364' inside conduit 406 has at least the thickness of electrical insulators 364 in insulated conductors 410. The increased thickness of insulation in heater 412 (from electrical insulators 364 and/or electrical insulator 364') inhibits and may prevent current leakage into the formation from the heater. In some embodiments, electrical insulator 364' spatially locates insulated conductors 410 inside conduit 406.

[0643] FIG. 34 depicts an embodiment of three-phase wye transformer 414 coupled to a plurality of heaters 412. For simplicity in the drawing, only four heaters 412 are shown in FIG. 34. It is to be understood that several more heaters may be coupled to the transformer 414. As shown in FIG. 34, each leg (each insulated conductor) of each heater is coupled to one phase of transformer 414 and current is returned to the neutral or ground of the transformer (for example, returned through conductor 416 depicted in FIGS. 33 and 35).

[0644] Return conductor 416 may be electrically coupled to the ends of insulated conductors 410 (as shown in FIG. 35) current returns from the ends of the insulated conductors to the transformer on the surface of the formation. Return conductor 416 may include high electrical conductivity materials such as pure copper, nickel, copper alloys, or combinations

thereof so that the return conductor provides little or no heat output. In some embodiments, return conductor 416 is a tubular (for example, a stainless steel tubular) that allows an optical fiber to be placed inside the tubular to be used for temperature and/or other measurement. In some embodiments, return conductor 416 is a small insulated conductor (for example, small mineral insulated conductor). Return conductor 416 may be coupled to the neutral or ground leg of the transformer in a three-phase wye configuration. Thus, insulated conductors 410 are electrically isolated from conduit 406 and the formation. Using return conductor 416 to return current to the surface may make coupling the heater to a wellhead easier. In some embodiments, current is returned using one or more of jackets 370, depicted in FIG. 33. One or more jackets 370 may be coupled to cores 374 at the end of the heaters and return current to the neutral of the three-phase wye transformer.

[0645] FIG. 35 depicts a side view representation of the end section of three insulated conductors 410 in conduit 406. The end section is the section of the heaters the furthest away from (distal from) the surface of the formation. The end section includes contactor section 418 coupled to conduit 406. In some embodiments, contactor section 418 is welded or brazed to conduit 406. Termination 420 is located in contactor section 418. Termination 420 is electrically coupled to insulated conductors 410 and return conductor 416. Termination 420 electrically couples the cores of insulated conductors 410 to the return conductor 416 at the ends of the heaters.

[0646] In certain embodiments, heater 412, depicted in FIGS. 33 and 35, includes an overburden section using copper as the core of the insulated conductors. The copper in the overburden section may be the same diameter as the cores used in the heating section of the heater. The copper in the overburden section may have a larger diameter than the cores in the heating section of the heater. Increasing the size of the copper in the overburden section may decrease losses in the overburden section of the heater.

[0647] Heaters that include three insulated conductors 410 in conduit 406, as depicted in FIGS. 33 and 35, may be made in a multiple step process. In some embodiments, the multiple step process is performed at the site of the formation or treatment area. In some embodiments, the multiple step process is performed at a remote manufacturing site away from the formation. The finished heater is then transported to the treatment area.

[0648] Insulated conductors 410 may be pre-assembled prior to the bundling either on site or at a remote location. Insulated conductors 410 and return conductor 416 may be positioned on spools. A machine may draw insulated conductors 410 and return conductor 416 from the spools at a selected rate. Preformed blocks of insulation material may be positioned around return conductor 416 and insulated conductors 410. In an embodiment, two blocks are positioned around return conductor 416 and three blocks are positioned around insulated conductors 410 to form electrical insulator 364'. The insulated conductors and return conductor may be drawn or pushed into a plate of conduit material that has been rolled into a tubular shape. The edges of the plate may be pressed together and welded (for example, by laser welding). After forming conduit 406 around electrical insulator 364', the bundle of insulated conductors 410, and return conductor 416, the conduit may be compacted against the electrical insulator 416 so that all of the components of the heater are

pressed together into a compact and tightly fitting form. During the compaction, the electrical insulator may flow and fill any gaps inside the heater.

[0649] In some embodiments, heater 412 (which includes conduit 406 around electrical insulator 364' and the bundle of insulated conductors 410 and return conductor 416) is inserted into a coiled tubing tubular that is placed in a wellbore in the formation. The coiled tubing tubular may be left in place in the formation (left in during heating of the formation) or removed from the formation after installation of the heater. The coiled tubing tubular may allow for easier installation of heater 412 into the wellbore.

[0650] In some embodiments, one or more components of heater 412 are varied (for example, removed, moved, or replaced) while the operation of the heater remains substantially identical. FIG. 36 depicts an embodiment of heater 412 with three insulated cores 374 in conduit 406. In this embodiment, electrical insulator 364' surrounds cores 374 and return conductor 416 in conduit 406. Cores 374 are located in conduit 406 without an electrical insulator and jacket surrounding the cores. Cores 374 are coupled to the single transformer in a three-phase wye configuration with each core 374 coupled to one phase of the transformer. Return conductor 416 is electrically coupled to the ends of cores 374 and returns current from the ends of the cores to the transformer on the surface of the formation.

[0651] FIG. 37 depicts an embodiment of heater 412 with three insulated conductors 410 and insulated return conductor in conduit 406. In this embodiment, return conductor 416 is an insulated conductor with core 374, electrical insulator 364', and jacket 370. Return conductor 416 and insulated conductors 410 are located in conduit 406 surrounded by electrical insulator 364'. Return conductor 416 and insulated conductors 410 may be the same size or different sizes. Return conductor 416 and insulated conductors 410 operate substantially the same as in the embodiment depicted in FIGS. 33 and 35.

[0652] Mineral insulated (MI) cables (insulated conductors) for use in subsurface applications, such as heating hydrocarbon containing formations in some applications, are longer, may have larger outside diameters, and may operate at higher voltages and temperatures than what is typical in the MI cable industry. For these subsurface applications, the joining of multiple MI cables is needed to make MI cables with sufficient length to reach the depths and distances needed to heat the subsurface efficiently and to join segments with different functions, such as lead-in cables joined to heater sections. Such long heaters also require higher voltages to provide enough power to the farthest ends of the heaters.

[0653] Conventional MI cable splice designs are typically not suitable for voltages above 1000 volts, above 1500 volts, or above 2000 volts and may not operate for extended periods without failure at elevated temperatures, such as over 650° C. (about 1200° F.), over 700° C. (about 1290° F.), or over 800° C. (about 1470° F.). Such high voltage, high temperature applications typically require the compaction of the mineral insulant in the splice to be as close as possible to or above the level of compaction in the insulated conductor (MI cable) itself.

[0654] The relatively large outside diameter and long length of MI cables for some applications requires that the cables be spliced while oriented horizontally. There are splices for other applications of MI cables that have been fabricated horizontally. These techniques typically use a

small hole through which the mineral insulation (such as magnesium oxide powder) is filled into the splice and compacted slightly through vibration and tamping. Such methods do not provide sufficient compaction of the mineral insulation or even allow any compaction of the mineral insulation, and are not suitable for making splices for use at the high voltages needed for these subsurface applications.

[0655] Thus, there is a need for splices of insulated conductors that are simple yet can operate at the high voltages and temperatures in the subsurface environment over long durations without failure. In addition, the splices may need higher bending and tensile strengths to inhibit failure of the splice under the weight loads and temperatures that the cables can be subjected to in the subsurface. Techniques and methods also may be utilized to reduce electric field intensities in the splices so that leakage currents in the splices are reduced and to increase the margin between the operating voltage and electrical breakdown. Reducing electric field intensities may help increase voltage and temperature operating ranges of the splices.

[0656] FIG. 38 depicts a side view cross-sectional representation of one embodiment of a fitting for joining insulated conductors. Fitting 422 is a splice or coupling joint for joining insulated conductors 410A, 410B. In certain embodiments, fitting 422 includes sleeve 424 and housings 426A, 426B. Housings 426A, 426B may be splice housings, coupling joint housings, coupler housings. Sleeve 424 and housings 426A, 426B may be made of mechanically strong, electrically conductive materials such as, but not limited to, stainless steel. Sleeve 424 and housings 426A, 426B may be cylindrically shaped or polygon shaped. Sleeve 424 and housings 426A, 426B may have rounded edges, tapered diameter changes, other features, or combinations thereof, which may reduce electric field intensities in fitting 422.

[0657] Fitting 422 may be used to couple (splice) insulated conductor 410A to insulated conductor 410B while maintaining the mechanical and electrical integrity of the jackets (sheaths), insulation, and cores (conductors) of the insulated conductors. Fitting 422 may be used to couple heat producing insulated conductors with non-heat producing insulated conductors, to couple heat producing insulated conductors with other heat producing insulated conductors, or to couple non-heat producing insulated conductors with other non-heat producing insulated conductors. In some embodiments, more than one fitting 422 is used in to couple multiple heat producing and non-heat producing insulated conductors to produce a long insulated conductor.

[0658] Fitting 422 may be used to couple insulated conductors with different diameters, as shown in FIG. 38. For example, the insulated conductors may have different core (conductor) diameters, different jacket (sheath) diameters, or combinations of different diameters. Fitting 422 may also be used to couple insulated conductors with different metallurgies, different types of insulation, or a combination thereof.

[0659] As shown in FIG. 38, housing 426A is coupled to jacket (sheath) 370A of insulated conductor 410A and housing 426B is coupled to jacket 370B of insulated conductor 410B. In certain embodiments, housings 426A, 426B are welded, brazed, or otherwise permanently affixed to insulated conductors 410A, 410B. In some embodiments, housings 426A, 426B are temporarily or semi-permanently affixed to jackets 370A, 370B of insulated conductors 410A, 410B (for

example, coupled using threads or adhesives). Fitting 422 may be centered between the end portions of the insulated conductors 410A, 410B.

[0660] In certain embodiments, the interior volumes of sleeve 424 and housings 426A, 426B are substantially filled with electrically insulating material 430. In certain embodiments, substantially filled refers to entirely or almost entirely filling the volume or volumes with electrically insulating material with substantially no macroscopic voids in the volume or volumes. For example, substantially filled may refer to filling almost the entire volume with electrically insulating material that has some porosity because of microscopic voids (for example, up to about 40% porosity). Electrically insulating material 430 may be magnesium oxide, other electrical insulators such as ceramic powders (for example, boron nitride), a mixture of magnesium oxide and another electrical insulator (for example, up to about 50% by volume boron nitride), ceramic cement, mixtures of ceramic powders with certain non-ceramic materials, or mixtures thereof. For example, magnesium oxide may be mixed with boron nitride or another electrical insulator to improve the ability of the electrically insulating material to flow or to improve the dielectric characteristics of the electrically insulating material. In some embodiments, electrically insulating material 430 is material similar to electrical insulation used inside of at least one of insulated conductors 410A, 410B. Electrically insulating material 430 may have substantially similar dielectric characteristics to electrical insulation used inside of at least one of insulated conductors 410A, 410B.

[0661] In certain embodiments, first sleeve 424 and housings 426A, 426B are made up (for example, put together or manufactured) buried or submerged in electrically insulating material 430. Making up sleeve 424 and housings 426A, 426B buried in electrically insulating material 430 inhibits open space from forming in the interior volumes of the portions. Sleeve 424 and housings 426A, 426B have open ends to allow insulated conductors 410A, 410B to pass through. These open ends may be sized to have diameters slightly larger than the outside diameter of the jackets of the insulated conductors.

[0662] In certain embodiments, cores 374A, 374B of insulated conductors 410A, 410B are joined together at coupling 428. The jackets and insulation of insulated conductors 410A, 410B may be cut back or stripped to expose desired lengths of cores 374A, 374B before joining the cores. Coupling 428 may be located in electrically insulating material 430 inside sleeve 424. Coupling 428 may join cores 374A, 374B together, for example, by compression, crimping, brazing, welding, or other techniques known in the art.

[0663] In an embodiment, insulated conductors 410A, 410B are coupled using fitting 422 by first sliding housing 426A over jacket 370A of insulated conductor 410A and, second, sliding housing 426B over jacket 370B of insulated conductor 410B. The housings are slid over the jackets with the large diameter ends of the housings facing the ends of the insulated conductors. Sleeve 424 may be slid over insulated conductor 410B such that it is adjacent to housing 426B. Cores 374A, 374B are joined at coupling 428 to create a robust electrical and mechanical connection between the cores. The small diameter end of housing 426A is joined (for example, welded) to jacket 370A of insulated conductor 410A. Sleeve 424 and housing 426B are brought (moved or pushed) together with housing 426A to form fitting 422. The interior volume of fitting 422 may be substantially filled with

electrically insulating material while the sleeve and the housings are brought together. The interior volume of the combined sleeve and housings is reduced such that the electrically insulating material substantially filling the entire interior volume is compacted. Sleeve 424 is joined to housing 426B and housing 426B is joined to jacket 370B of insulated conductor 410B. The volume of sleeve 424 may be further reduced, if additional compaction is desired.

[0664] In certain embodiments, the interior volumes of housings 426A, 426B filled with electrically insulating material 430 have tapered shapes. The diameter of the interior volumes of housings 426A, 426B may taper from a smaller diameter at or near the ends of the housings coupled to insulated conductors 410A, 410B to a larger diameter at or near the ends of the housings located inside sleeve 424 (the ends of the housings facing each other or the ends of the housings facing the ends of the insulated conductors). The tapered shapes of the interior volumes may reduce electric field intensities in fitting 422. Reducing electric field intensities in fitting 422 may reduce leakage currents in the fitting at increased operating voltages and temperatures, and may increase the margin to electrical breakdown. Thus, reducing electric field intensities in fitting 422 may increase the range of operating voltages and temperatures for the fitting.

[0665] In some embodiments, the insulation from insulated conductors 410A, 410B tapers from jackets 370A, 370B down to cores 374A, 374B in the direction toward the center of fitting 422 in the event that the electrically insulating material 430 is a weaker dielectric than the insulation in the insulated conductors. In some embodiments, the insulation from insulated conductors 410A, 410B tapers from jackets 370A, 370B down to cores 374A, 374B in the direction toward the insulated conductors in the event that electrically insulating material 430 is a stronger dielectric than the insulation in the insulated conductors. Tapering the insulation from the insulated conductors reduces the intensity of electric fields at the interfaces between the insulation in the insulated conductors and the electrically insulating material within the fitting.

[0666] FIG. 39 depicts a tool that may be used to cut away part of the inside of insulated conductors 410A, 410B (for example, electrical insulation inside the jacket of the insulated conductor). Cutting tool 436 may include cutting teeth 438 and drive tube 440. Drive tube 440 may be coupled to the body of cutting tool 436 using, for example, a weld or braze. In some embodiments, no cutting tool is needed to cut away electrical insulation from inside the jacket.

[0667] Sleeve 424 and housings 426A, 426B may be coupled together using any means known in the art such as brazing, welding, or crimping. In some embodiments, in the embodiment shown in FIG. 40, sleeve 424 and housings 426A, 426B have threads that engage to couple the pieces together.

[0668] As shown in FIGS. 38 and 40, in certain embodiments, electrically insulating material 430 is compacted during the assembly process. The force to press the housings 426A, 426B toward each other may put a pressure on electrically insulating material 430 of at least 25,000 pounds per square inch, or between 25,000 and 55,000 pounds per square inch, in order to provide acceptable compaction of the insulating material. The tapered shapes of the interior volumes of housings 426A, 426B and the make-up of electrically insulating material 430 may enhance compaction of the electrically insulating material during the assembly process to the

point where the dielectric characteristics of the electrically insulating material are, to the extent practical, comparable to that within insulated conductors 410A, 410B. Methods and devices to facilitate compaction include, but are not limited to, mechanical methods (such as shown in FIG. 43), pneumatic, hydraulic (such as shown in FIGS. 44 and 45), swaged, or combinations thereof.

[0669] The combination of moving the pieces together with force and the housings having the tapered interior volumes compacts electrically insulating material 430 using both axial and radial compression. Using both axial and radial compression of electrically insulating material 430 provides more uniform compaction of the electrically insulating material. In some embodiments, vibration and/or tamping of electrically insulating material 430 may also be used to consolidate the electrically insulating material. Vibration (and/or tamping) may be applied either at the same time as application of force to push the housings 426A, 426B together, or vibration (and/or tamping) may be alternated with application of such force. Vibration and/or tamping may reduce bridging of particles in electrically insulating material 430.

[0670] In the embodiment depicted in FIG. 40, electrically insulating material 430 inside housings 426A, 426B is compressed mechanically by tightening nuts 434 against ferrules 432 coupled to jackets 370A, 370B. The mechanical method compacts the interior volumes of housings 426A, 426B because of the tapered shape of the interior volumes. Ferrules 432 may be copper or other soft metal ferrules. Nuts 434 may be stainless steel or other hard metal nut that is movable on jackets 370A, 370B. Nuts 434 may engage threads on housings 426A, 426B to couple to the housings. As nuts 434 are threaded onto housings 426A, 426B, nuts 434 and ferrules 432 work to compress the interior volumes of the housings. In some embodiments, nuts 434 and ferrules 432 may work to move housings 426A, 426B further onto sleeve 424 (using the threaded coupling between the pieces) and compact the interior volume of the sleeve. In some embodiments, housings 426A, 426B and sleeve 424 are coupled together using the threaded coupling before the nut and ferrule are swaged down on the second portion. As the interior volumes inside housings 426A, 426B are compressed, the interior volume inside sleeve 424 may also be compressed. In some embodiments, nuts 434 and ferrules 432 may act to couple housings 426A, 426B to insulated conductors 410A, 410B.

[0671] In certain embodiments, multiple insulated conductors are spliced together in an end fitting. For example, three insulated conductors may be spliced together in an end fitting to couple electrically the insulated conductors in a 3-phase wye configuration. FIG. 41A depicts a side view of a cross-sectional representation of an embodiment of threaded fitting 442 for coupling three insulated conductors 410A, 410B, 410C. FIG. 41B depicts a side view of a cross-sectional representation of an embodiment of welded fitting 442 for coupling three insulated conductors 410A, 410B, 410C. As shown in FIGS. 41A and 41B, insulated conductors 410A, 410B, 410C may be coupled to fitting 442 through end cap 444. End cap 444 may include three strain relief fittings 446 through which insulated conductors 410A, 410B, 410C pass.

[0672] Cores 374A, 374B, 374C of the insulated conductors may be coupled together at coupling 428. Coupling 428 may be, for example, a braze (such as a silver braze or copper braze), a welded joint, or a crimped joint. Coupling cores 374A, 374B, 374C at coupling 428 electrically join the three insulated conductors for use in a 3-phase wye configuration.

[0673] As shown in FIG. 41A, end cap 444 may be coupled to main body 448 of fitting 442 using threads. Threading of end cap 444 and main body 448 may allow the end cap to compact electrically insulating material 430 inside the main body. At the end of main body 448 opposite of end cap 444 is cover 450. Cover 450 may also be attached to main body 448 by threads. In certain embodiments, compaction of electrically insulating material 430 in fitting 442 is enhanced through tightening of cover 450 into main body 448, by crimping of the main body after attachment of the cover, or a combination of these methods.

[0674] As shown in FIG. 41B, end cap 444 may be coupled to main body 448 of fitting 442 using welding, brazing, or crimping. End cap 444 may be pushed or pressed into main body 448 to compact electrically insulating material 430 inside the main body. Cover 450 may also be attached to main body 448 by welding, brazing, or crimping. Cover 450 may be pushed or pressed into main body 448 to compact electrically insulating material 430 inside the main body. Crimping of the main body after attachment of the cover may further enhance compaction of electrically insulating material 430 in fitting 442.

[0675] In some embodiments, as shown in FIGS. 41A and 41B, plugs 452 close openings or holes in cover 450. For example, the plugs may be threaded, welded, or brazed into openings in cover 450. The openings in cover 450 may allow electrically insulating material 430 to be provided inside fitting 442 when cover 450 and end cap 444 are coupled to main body 448. The openings in cover 450 may be plugged or covered after electrically insulating material 430 is provided inside fitting 442. In some embodiments, openings are located on main body 448 of fitting 442. Openings on main body 448 may be plugged with plugs 452 or other plugs.

[0676] In some embodiments, cover 450 includes one or more pins. In some embodiments, the pins are or are part of plugs 452. The pins may engage a torque tool that turns cover 450 and tightens the cover on main body 448. An example of torque tool 454 that may engage the pins is depicted in FIG. 42. Torque tool 454 may have an inside diameter that substantially matches the outside diameter of cover 450 (depicted in FIG. 41A). As shown in FIG. 42, torque tool 454 may have slots or other depressions that are shaped to engage the pins on cover 450. Torque tool 454 may include recess 456. Recess 456 may be a square drive recess or other shaped recess that allows operation (turning) of the torque tool.

[0677] FIG. 43 depicts an embodiment of clamp assemblies 458A,B that may be used to mechanically compact fitting 422. Clamp assemblies 458A,B may be shaped to secure fitting 422 in place at the shoulders of housings 426A, 426B. Threaded rods 462 may pass through holes 460 of clamp assemblies 458A,B. Nuts 468, along with washers, on each of threaded rods 462 may be used to apply force on the outside faces of each clamp assembly and bring the clamp assemblies together such that compressive forces are applied to housings 426A, 426B of fitting 422. These compressive forces compact electrically insulating material inside fitting 422.

[0678] In some embodiments, clamp assemblies 458 are used in hydraulic, pneumatic, or other compaction methods. FIG. 44 depicts an exploded view of an embodiment of hydraulic compaction machine 464. FIG. 45 depicts a representation of an embodiment of assembled hydraulic compaction machine 464. As shown in FIGS. 44 and 45, clamp assemblies 458 may be used to secure fitting 422 (depicted, for example, in FIG. 38) in place with insulated conductors

coupled to the fitting. At least one clamp assembly (for example, clamp assembly 458A) may be moveable together to compact the fitting in the axial direction. Power unit 466, shown in FIG. 44, may be used to power compaction machine 464.

[0679] FIG. 46 depicts an embodiment of fitting 422 and insulated conductors 410A, 410B secured in clamp assembly 458A and clamp assembly 458B before compaction of the fitting and insulated conductors. As shown in FIG. 46, the cores of insulated conductors 410A, 410B are coupled using coupling 428 at or near the center of sleeve 424. Sleeve 424 is slid over housing 426A, which is coupled to insulated conductor 410A. Sleeve 424 and housing 426A are secured in fixed (non-moving) clamp assembly 458B. Insulated conductor 410B passes through housing 426B and movable clamp assembly 458A. Insulated conductor 410B may be secured by another clamp assembly fixed relative to clamp assembly 458B (not shown). Clamp assembly 458A may be moved towards clamp assembly 458B to couple housing 426B to sleeve 424 and compact electrically insulating material inside the housings and the sleeve. Interfaces between insulated conductor 410A and housing 426A, between housing 426A and sleeve 424, between sleeve 424 and housing 426B, and between housing 426B and insulated conductor 410B may then be coupled by welding, brazing, or other techniques known in the art.

[0680] FIG. 47 depicts a side view representation of an embodiment of fitting 470 for joining insulated conductors. Fitting 470 may be a cylinder or sleeve that has sufficient clearance between the inside diameter of the sleeve and the outside diameters of insulated conductors 410A, 410B such that the sleeve fits over the ends of the insulated conductors. The cores of insulated conductors 410A, 410B may be joined inside fitting 470. The jackets and insulation of insulated conductors 410A, 410B may be cut back or stripped to expose desired lengths of the cores before joining the cores. Fitting 470 may be centered between the end portions of insulated conductors 410A, 410B.

[0681] Fitting 470 may be used to couple insulated conductor 410A to insulated conductor 410B while maintaining the mechanical and electrical integrity of the jackets, insulation, and cores of the insulated conductors. Fitting 470 may be used to couple heat producing insulated conductors with non-heat producing insulated conductors, to couple heat producing insulated conductors with other heat producing insulated conductors, or to couple non-heat producing insulated conductors with other non-heat producing insulated conductors. In some embodiments, more than one fitting 470 is used in to couple multiple heat producing and non-heat producing insulated conductors to produce a long insulated conductor.

[0682] Fitting 470 may be used to couple insulated conductors with different diameters. For example, the insulated conductors may have different core diameters, different jacket diameters, or combinations of different diameters. Fitting 470 may also be used to couple insulated conductors with different metallurgies, different types of insulation, or a combination thereof.

[0683] In certain embodiments, fitting 470 has at least one angled end. For example, the ends of fitting 470 may be angled relative to the longitudinal axis of the fitting. The angle may be, for example, about 45° or between 30° and 60°. Thus, the ends of fitting 470 may have substantially elliptical cross-sections. The substantially elliptical cross-sections of the ends of fitting 470 provide a larger area for welding or brazing

of the fitting to insulated conductors 410A, 410B. The larger coupling area increases the strength of spliced insulated conductors. In the embodiment shown in FIG. 47, the angled ends of fitting 470 give the fitting a substantially parallelogram shape.

[0684] The angled ends of fitting 470 provide higher tensile strength and higher bending strength for the fitting than if the fitting had straight ends by distributing loads along the fitting. Fitting 470 may be oriented so that when insulated conductors 410A, 410B and the fitting are spooled (for example, on a coiled tubing installation), the angled ends act as a transition in stiffness from the fitting body to the insulated conductors. This transition reduces the likelihood of the insulated conductors to kink or crimp at the end of the fitting body.

[0685] As shown in FIG. 47, fitting 470 includes opening 472. Opening 472 allows electrically insulating material (such as electrically insulating material 430, depicted in FIG. 38) to be provided (filled) inside fitting 470. Opening 472 may be a slot or other longitudinal opening extending along part of the length of fitting 470. In certain embodiments, opening 472 extends substantially the entire gap between the ends of insulated conductors 410A, 410B inside fitting 470. Opening 472 allows substantially the entire volume (area) between insulated conductors 410A, 410B, and around any welded or spliced joints between the insulated conductors, to be filled with electrically insulating material without the insulating material having to be moved axially toward the ends of the volume between the insulated conductors. The width of opening 472 allows electrically insulating material to be forced into the opening and packed more tightly inside fitting 470, thus, reducing the amount of void space inside the fitting. Electrically insulating material may be forced through the slot into the volume between insulated conductors 410A, 410B, for example, with a tool with the dimensions of the slot. The tool may be forced into the slot to compact the insulating material. Then, additional insulating material may be added and the compaction is repeated. In some embodiments, the electrically insulating material may be further compacted inside fitting 470 using vibration, tamping, or other techniques. Further compacting the electrically insulating material may more uniformly distribute the electrically insulating material inside fitting 470.

[0686] After filling electrically insulating material inside fitting 470 and, in some embodiment, compaction of the electrically insulating material, opening 472 may be closed. For example, an insert or other covering may be placed over the opening and secured in place. FIG. 48 depicts a side view representation of an embodiment of fitting 470 with opening 472 covered with insert 474. Insert 474 may be welded or brazed to fitting 470 to close opening 472. In some embodiments, insert 474 is ground or polished so that the insert is flush on the surface of fitting 470. Also depicted in FIG. 48, welds or brazes 476 may be used to secure fitting 470 to insulated conductors 410A, 410B.

[0687] After opening 472 is closed, fitting 470 may be compacted mechanically, hydraulically, pneumatically, or using swaging methods to compact further the electrically insulating material inside the fitting. Further compaction of the electrically insulating material reduces void volume inside fitting 470 and reduces the leakage currents through the fitting and increases the operating range of the fitting (for example, the maximum operating voltages or temperatures of the fitting).

[0688] In certain embodiments, fitting 470 includes certain features that may further reduce electric field intensities inside the fitting. For example, fitting 470 or coupling 428 of the cores of the insulated conductors inside the fitting may include tapered edges, rounded edges, or other smoothed out features to reduce electric field intensities. FIG. 49 depicts an embodiment of fitting 470 with electric field reducing features at coupling 428 between insulated conductors 410A, 410B. As shown in FIG. 49, coupling 428 is a welded joint with a smoothed out or rounded profile to reduce electric field intensity inside fitting 470. In addition, fitting 470 has a tapered interior volume to increase the volume of electrically insulating material inside the fitting. Having the tapered and larger volume may reduce electric field intensities inside fitting 470.

[0689] In some embodiments, electric field stress reducers may be located inside fitting 470 to decrease the electric field intensity. FIG. 50 depicts an embodiment of electric field stress reducer 478. Reducer 478 may be located in the interior volume of fitting 470 (shown in FIG. 49). Reducer 478 may be a split ring or other separable piece so that the reducer can be fitted around cores 374A, 374B of insulated conductors 410A, 410B after they are joined (shown in FIG. 49).

[0690] The fittings depicted herein (such as fitting 422, depicted in FIGS. 38 and 40, fitting 442, depicted in FIG. 41, and fitting 470, depicted in FIGS. 47, 48, and 49) may form robust electrical and mechanical connections between insulated conductors. For example, fittings depicted herein may be suitable for extended operation at voltages above 1000 volts, above 1500 volts, or above 2000 volts and temperatures of at least about 650° C., at least about 700° C., at least about 800° C.

[0691] In some embodiments, three insulated conductor heaters (for example, mineral insulated conductor heaters) are coupled together into a single assembly. The single assembly may be built in long lengths and may operate at high voltages (for example, voltages of 4000 V nominal). In certain embodiments, the individual insulated conductor heaters are enclosed in corrosive resistant jackets to resist damage from the external environment. The jackets may be, for example, seam welded stainless steel armor similar to that used on type MC/CWCMC cable.

[0692] In some embodiments, three insulated conductor heaters are cabled and the insulating filler added in conventional methods known in the art. The insulated conductor heaters may include one or more heater sections that resistively heat and provide heat to formation adjacent to the heater sections. The insulated conductors may include one or more other sections that provide electricity to the heater sections with relatively small heat loss. The individual insulated conductor heaters may be wrapped with high temperature fiber tapes before being placed on a take-up reel (for example, a coiled tubing rig). The reel assembly may be moved to another machine for application of an outer metallic sheath or outer protective conduit.

[0693] In some embodiments, the fillers include glass, ceramic or other temperature resistant fibers that withstand operating temperature of 760° C. or higher. In addition, the insulated conductor cables may be wrapped in multiple layers of a ceramic fiber woven tape material. By wrapping the tape around the cabled insulated conductor heaters prior to application of the outer metallic sheath, electrical isolation is provided between the insulated conductor heaters and the outer sheath. This electrical isolation inhibits leakage current from

the insulated conductor heaters passing into the subsurface formation and forces any leakage currents to return directly to the power source on the individual insulated conductor sheaths and/or on a lead-in conductor or lead-out conductor coupled to the insulated conductors. The lead-in or lead-out conductors may be coupled to the insulated conductors when the insulated conductors are placed into an assembly with the outer metallic sheath.

[0694] In certain embodiments, the insulated conductor heaters are wrapped with a metallic tape or other type of tape instead of the high temperature ceramic fiber woven tape material. The metallic tape holds the insulated conductor heaters together. A widely-spaced wide pitch spiral wrapping of a high temperature fiber rope may be wrapped around the insulated conductor heaters. The fiber rope may provide electrical isolation between the insulated conductors and the outer sheath. The fiber rope may be added at any stage during assembly. For example, the fiber rope may be added as a part of the final assembly when the outer sheath is added. Application of the fiber rope may be simpler than other electrical isolation methods because application of the fiber rope is done with only a single layer of rope instead of multiple layers of ceramic tape. The fiber rope may be less expensive than multiple layers of ceramic tape. The fiber rope may increase heat transfer between the insulated conductors and the outer sheath and/or reduce interference with any welding process used to weld the outer sheath around the insulated conductors (for example, seam welding).

[0695] In certain embodiments, an insulated conductor or another type of heater is installed in a wellbore or opening in the formation using outer tubing coupled to a coiled tubing rig. FIG. 51 depicts outer tubing 480 partially unspooled from coiled tubing rig 482. Outer tubing 480 may be made of metal or polymeric material. Outer tubing 480 may be a flexible conduit such as, for example, a tubing guide string or other coiled tubing string. Heater 412 may be pushed into outer tubing 480, as shown in FIG. 52. In certain embodiments, heater 412 is pushed into outer tubing 480 by pumping the heater into the outer tubing.

[0696] In certain embodiments, one or more flexible cups 484 are coupled to the outside of heater 412. Flexible cups 484 may have a variety of shapes and/or sizes but typically are shaped and sized to maintain at least some pressure inside at least a portion of outer tubing 480 as heater 412 is pushed or pumped into the outer tubing. Flexible cups 484 are made of flexible materials such as, but not limited to, elastomeric materials. For example, flexible cups 484 may have flexible edges that provide limited mechanical resistance as heater 412 is pushed into outer tubing 480 but remain in contact with the inner walls of outer tubing 480 as the heater is pushed so that pressure is maintained between the heater and the outer tubing. Maintaining at least some pressure in outer tubing 480 between flexible cups 484 allows heater 412 to be continuously pushed into the outer tubing with lower pump pressures. Without flexible cups 484, higher pressures may be needed to push heater 412 into outer tubing 480. In some embodiments, cups 484 allow some pressure to be released while maintaining pressure in outer tubing 480. In certain embodiments, flexible cups 484 are spaced to distribute pumping forces optimally along heater 412 inside outer tubing 480. For example, flexible cups 484 may be evenly spaced along heater 412.

[0697] Heater 412 is pushed into outer tubing 480 until the heater is fully inserted into the outer tubing, as shown in FIG.

53. Drilling guide 486 may be coupled to the end of heater 412. Heater 412, outer tubing 480, and drilling guide 486 may be spooled onto coiled tubing rig 482, as shown in FIG. 54. After heater 412, outer tubing 480, and drilling guide 486 are spooled onto coiled tubing rig 482, the assembly may be transported to a location for installation of the heater. For example, the assembly may be transported to the location of a subsurface heater wellbore (opening).

[0698] FIG. 55 depicts coiled tubing rig 482 being used to install heater 412 and outer tubing 480 into opening 386 using drilling guide 486. In certain embodiments, opening 386 is an L-shaped opening or wellbore with a substantially horizontal or inclined portion in a hydrocarbon containing layer of the formation. In such embodiments, heater 412 has a heating section that is placed in the substantially horizontally or inclined portion of opening 386 to be used to heat the hydrocarbon containing layer. In some embodiments, opening 386 has a horizontal or inclined section that is at least about 1000 m in length, at least about 1500 m in length, or at least about 2000 m in length. Overburden casing 398 may be located around the outer walls of opening 386 in an overburden section of the formation. In some embodiments, drilling fluid is left in opening 386 after the opening has been completed (the opening has been drilled).

[0699] FIG. 56 depicts heater 412 and outer tubing 480 installed in opening 386. Gap 488 may be left at or near the far end of heater 412 and outer tubing 480. Gap 488 may allow for heater expansion in opening 386 after the heater is energized.

[0700] After heater 412 and outer tubing 480 are installed in opening 386, the outer tubing may be removed from the opening to leave the heater in place in the opening. FIG. 57 depicts outer tubing 480 being removed from opening 386 while leaving heater 412 installed in the opening. Outer tubing 480 is spooled back onto coiled tubing rig 482 as the outer tubing is pulled off heater 412. In some embodiments, outer tubing 480 is pumped down to balance pressure between opening 386 and the outer tubing. Balancing the pressure allows outer tubing 480 to be pulled off heater 412.

[0701] FIG. 58 depicts outer tubing 480 used to provide packing material 402 into opening 386. As outer tubing 480 reaches the "shoe" or bend in opening 386, the outer tubing may be used to provide packing material into the opening. The shoe of opening 386 may be located at or near the bottom of overburden casing 398. Packing material 402 may be provided (for example, pumped) through outer tubing 480 and out the end of the outer tubing at the shoe of opening 386. Packing material 402 is provided into opening 386 to seal off the opening around heater 412. Packing material 402 provides a barrier between the overburden section and the heating section of opening 386. In certain embodiments, packing material 402 is cement or another suitable plugging material. In some embodiments, outer tubing 480 is continuously spooled while packing material 402 is provided into opening 386. Outer tubing 480 may be spooled slowly while packing material 402 is provided into opening 386 to allow the packing material to settle into the opening properly.

[0702] After packing material 402 is provided into opening 386, outer tubing 480 is spooled further onto coiled tubing rig 482, as shown in FIG. 59. FIG. 60 depicts outer tubing 480 spooled onto coiled tubing rig 482 with heater 412 installed in opening 386. In certain embodiments, flexible cups 484 are spaced in the portion of opening 386 with overburden casing 398 to facilitate adequate stand-off of heater 412 in the over-

burden portion of the opening. Flexible cups **484** may electrically insulate heater **412** from overburden casing **398**. For example, flexible cups **484** may space apart heater **412** and overburden casing **398** such that they are not in physical contact with each other.

[0703] After outer tubing **480** is removed from opening **386**, wellhead **392** and/or other completions may be installed at the surface of the opening, as shown in FIG. **61**. When heater **412** is energized to begin heating, flexible cups **484** may begin to burn or melt off. In some embodiments, flexible cups **484** begin to burn or melt off at low temperatures during early stages of the heating process.

[0704] FIG. **62** depicts an embodiment of a heater in wellbore **490** in formation **492**. The heater includes insulated conductor **410** in conduit **382** with material **494** between the insulated conductor and the conduit. In some embodiments, insulated conductor **410** is a mineral insulated conductor. Electricity supplied to insulated conductor **410** resistively heats the insulated conductor. Insulated conductor conductively transfers heat to material **494**. Heat may transfer within material **494** by heat conduction and/or by heat convection. Radiant heat from insulated conductor **410** and/or heat from material **494** transfers to conduit **382**. Heat may transfer to the formation from the heater by conductive or radiative heat transfer from conduit **382**. Material **494** may be molten metal, molten salt, or other liquid. In some embodiments, a gas (for example, nitrogen, carbon dioxide, and/or helium) is in conduit **382** above material **494**. The gas may inhibit oxidation or other chemical changes of material **494**. The gas may inhibit vaporization of material **494**. U.S. Published Patent Application 2008-0078551 to DeVault et al., which is incorporated by reference as if fully set forth herein, describes a system for placement in a wellbore, the system including a heater in a conduit with a liquid metal between the heater and the conduit for heating subterranean earth.

[0705] Insulated conductor **410** and conduit **382** may be placed in an opening in a subsurface formation. Insulated conductor **410** and conduit **382** may have any orientation in a subsurface formation (for example, the insulated conductor and conduit may be substantially vertical or substantially horizontally oriented in the formation). Insulated conductor **410** includes core **374**, electrical insulator **364**, and jacket **370**. In some embodiments, core **374** is a copper core. In some embodiments, core **374** includes other electrical conductors or alloys (for example, copper alloys). In some embodiments, core **374** includes a ferromagnetic conductor so that insulated conductor **410** operates as a temperature limited heater. In some embodiments, core **374** does not include a ferromagnetic conductor.

[0706] In some embodiments, core **374** of insulated conductor **410** is made of two or more portions. The first portion may be placed adjacent to the overburden. The first portion may be sized and/or made of a highly conductive material so that the first portion does not resistively heat to a high temperature. One or more other portions of core **410** may be sized and/or made of material that resistively heats to a high temperature. These portions of core **410** may be positioned adjacent to sections of the formation that are to be heated by the heater. In some embodiments, the insulated conductor does not include a highly conductive first portion. A lead in cable may be coupled to the insulated conductor to supply electricity to the insulated conductor.

[0707] In some embodiments, core **374** of insulated conductor **410** is a highly conductive material such as copper.

Core **374** may be electrically coupled to jacket **370** at or near the end of the insulated conductor. In some embodiments, insulated conductor **410** is electrically coupled to conduit **382**. Electrical current supplied to insulated conductor **410** may resistively heat core **374**, jacket **370**, material **494**, and/or conduit **382**. Resistive heating of core **374**, jacket **370**, material **494**, and/or conduit **382** generates heat that may transfer to the formation.

[0708] Electrical insulator **364** may be magnesium oxide, aluminum oxide, silicon dioxide, beryllium oxide, boron nitride, silicon nitride, or combinations thereof. In certain embodiments, electrical insulator **364** is a compacted powder of magnesium oxide. In some embodiments, electrical insulator **364** includes beads of silicon nitride. In certain embodiments, a thin layer of material clad over core **374** to inhibit the core from migrating into the electrical insulator at higher temperatures (i.e., to inhibit copper of the core from migrating into magnesium oxide of the insulation). For example, a small layer of nickel (for example, about 0.5 mm of nickel) may be clad on core **374**.

[0709] In some embodiments, material **494** may be relatively corrosive. Jacket **370** and/or at least the inside surface of conduit **382** may be made of a corrosion resistant material such as, but not limited to, nickel, Alloy N (Carpenter Metals), 347 stainless steel, 347H stainless steel, 446 stainless steel, or 825 stainless steel. For example, conduit **382** may be plated or lined with nickel. In some embodiments, material **494** may be relatively non-corrosive. Jacket **370** and/or at least the inside surface of conduit **382** may be made of a material such as carbon steel.

[0710] In some embodiments, jacket **370** of insulated conductor **410** is not used as the main return of electrical current for the insulated conductor. In embodiments where material **494** is a good electrical conductor such as a molten metal, current returns through the molten metal in the conduit and/or through the conduit **382**. In some embodiments, conduit **382** is made of a ferromagnetic material, (for example 410 stainless steel). Conduit **382** may function as a temperature limited heater until the temperature of the conduit approaches, reaches or exceeds the Curie temperature or phase transition temperature of the conduit material.

[0711] In some embodiments, material **494** returns electrical current to the surface from insulated conductor **410** (i.e., the material acts as the return or ground conductor for the insulated conductor). Material **494** may provide a current path with low resistance so that a long insulated conductor **410** is useable in conduit **382**. The long heater may operate at low voltages for the length of the heater due to the presence of material **494** that is conductive.

[0712] FIG. **63** depicts an embodiment of a portion of insulated conductor **410** in conduit **382** wherein material **494** is a good conductor (for example, a liquid metal) and current flow is indicated by the arrows. Current flows down core **374** and returns through jacket **370**, material **494**, and conduit **382**. Jacket **370** and conduit **382** may be at approximately constant potential. Current flows radially from jacket **370** to conduit **382** through material **494**. Material **494** may resistively heat. Heat from material **494** may transfer through conduit **382** into the formation.

[0713] In embodiments where material **494** is partially electrically conductive (for example, the material is a molten salt), current returns mainly through jacket **370**. All or a portion of the current that passes through partially conductive material **494** may pass to ground through conduit **382**.

[0714] In the embodiment depicted in FIG. 62, core 374 of insulated conductor 410 has a diameter of about 1 cm, electrical insulator 364 has an outside diameter of about 1.6 cm, and jacket 370 has an outside diameter of about 1.8 cm. In other embodiments, the insulated conductor is smaller. For example, core 374 has a diameter of about 0.5 cm, electrical insulator 364 has an outside diameter of about 0.8 cm, and jacket 370 has an outside diameter of about 0.9 cm. Other insulated conductor geometries may be used. For the same size conduit 382, the smaller geometry of insulated conductor 410 may result in a higher operating temperature of the insulated conductor to achieve the same temperature at the conduit. The smaller geometry insulated conductors may be significantly more economically favorable due to manufacturing cost, weight, and other factors.

[0715] Material 494 may be placed between the outside surface of insulated conductor 410 and the inside surface of conduit 382. In certain embodiments, material 494 is placed in the conduit in a solid form as balls or pellets. Material 494 may melt below the operating temperatures of insulated conductor 410. Material may melt above ambient subsurface formation temperatures. Material 494 may be placed in conduit 382 after insulated conductor 410 is placed in the conduit. In certain embodiments, material 494 is placed in conduit 410 as a liquid. The liquid may be placed in conduit 382 before or after insulated conductor 410 is placed in the conduit (for example, the molten liquid may be poured into the conduit before or after the insulated conductor is placed in the conduit). Additionally, material 494 may be placed in conduit 382 before or after insulated conductor 410 is energized (i.e., supplied with electricity). Material 494 may be added to conduit 382 or removed from the conduit after operation of the heater is initialized. Material 494 may be added to or removed from conduit 382 to maintain a desired head of fluid in the conduit. In some embodiments, the amount of material 494 in conduit 382 may be adjusted (i.e., added to or depleted) to adjust or balance the stresses on the conduit. Material 494 may inhibit deformation of conduit 382. The head of material 494 in conduit 382 may inhibit the formation from crushing or otherwise deforming the conduit should the formation expand against the conduit. The head of fluid in conduit 382 allows the wall of the conduit to be relatively thin. Having thin conduits 382 may increase the economic viability of using multiple heaters of this type to heat portions of the formation.

[0716] Material 494 may support insulated conductor 410 in conduit 382. The support provided by material 494 of insulated conductor 410 may allow for the deployment of long insulated conductors as compared to insulated conductors positioned only in a gas in a conduit without the use of special metallurgy to accommodate the weight of the insulated conductor. In certain embodiments, insulated conductor 410 is buoyant in material 494 in conduit 382. For example, insulated conductor may be buoyant in molten metal. The buoyancy of insulated conductor 410 reduces creep associated problems in long, substantially vertical heaters. A bottom weight or tie down may be coupled to the bottom of insulated conductor 410 to inhibit the insulated conductor from floating in material 494.

[0717] Material 494 may remain a liquid at operating temperatures of insulated conductor 410. In some embodiments, material 494 melts at temperatures above about 100° C., above about 200° C., or above about 300° C. The insulated conductor may operate at temperatures greater than 200° C., greater than 400° C., greater than 600° C., or greater than

800° C. In certain embodiments, material 494 provides enhanced heat transfer from insulated conductor 410 to conduit 382 at or near the operating temperatures of the insulated conductor.

[0718] Material 494 may include metals such as tin, zinc, an alloy such as a 60% by weight tin, 40% by weight zinc alloy; bismuth; indium; cadmium, aluminum; lead; and/or combinations thereof (for example, eutectic alloys of these metals such as binary or ternary alloys). In one embodiment, material 494 is tin. Some liquid metals may be corrosive. The jacket of the insulated conductor and/or at least the inside surface of the canister may need to be made of a material that is resistant to the corrosion of the liquid metal. The jacket of the insulated conductor and/or at least the inside surface of the conduit may be made of materials that inhibit the molten metal from leaching materials from the insulating conductor and/or the conduit to form eutectic compositions or metal alloys. Molten metals may be highly thermal conductive, but may block radiant heat transfer from the insulated conductor and/or have relatively small heat transfer by natural convection.

[0719] Material 494 may be or include molten salts such as solar salt, salts presented in Table 1, or other salts. The molten salts may be infrared transparent to aid in heat transfer from the insulated conductor to the canister. In some embodiments, solar salt includes sodium nitrate and potassium nitrate (for example, about 60% by weight sodium nitrate and about 40% by weight potassium nitrate). Solar salt melts at about 220° C. and is chemically stable up to temperatures of about 593° C. Other salts that may be used include, but are not limited to LiNO₃ (melt temperature (T_m) of 264° C. and a decomposition temperature of about 600° C.) and eutectic mixtures such as 53% by weight KNO₃, 40% by weight NaNO₃ and 7% by weight NaNO₂ (T_m of about 142° C. and an upper working temperature of over 500° C.); 45.5% by weight KNO₃ and 54.5% by weight NaNO₂ (T_m of about 142-145° C. and an upper working temperature of over 500° C.); or 50% by weight NaCl and 50% by weight SrCl₂ (T_m of about 19° C. and an upper working temperature of over 1200° C.).

TABLE 1

Material	T_m (° C.)	T_b (° C.)
Zn	420	907
CdBr ₂	568	863
CdI ₂	388	744
CuBr ₂	498	900
PbBr ₂	371	892
TlBr	460	819
TlF	326	826
ThI ₄	566	837
SnF ₂	215	850
SnI ₂	320	714
ZnCl ₂	290	732

[0720] Some molten salts, such as solar salt, may be relatively non-corrosive so that the conduit and/or the jacket may be made of relatively inexpensive material (for example, carbon steel). Some molten salts may have good thermal conductivity, may have high heat density, and may result in large heat transfer by natural convection.

[0721] In fluid mechanics, the Rayleigh number is a dimensionless number associated with heat transfer in a fluid. When the Rayleigh number is below the critical value for the fluid, heat transfer is primarily in the form of conduction; and when the Rayleigh number is above the critical value, heat transfer

is primarily in the form of convection. The Rayleigh number is the product of the Grashof number (which describes the relationship between buoyancy and viscosity in a fluid) and the Prandtl number (which describes the relationship between momentum diffusivity and thermal diffusivity). For the same size insulated conductors in conduits, and where the temperature of the conduit is 500° C., the Rayleigh number for solar salt in the conduit is about 10 times the Rayleigh number for tin in the conduit. The higher Rayleigh number implies that the strength of natural convection in the molten solar salt is much stronger than the strength of the natural convection in molten tin. The stronger natural convection of molten salt may distribute heat and inhibit the formation of hot spots at locations along the length of the conduit. Hot spots may be caused by coke build up at isolated locations adjacent to or on the conduit, contact of the conduit by the formation at isolated locations, and/or other high thermal load situations.

[0722] Conduit 382 may be a carbon steel or stainless steel canister. In some embodiments, conduit 382 may include cladding on the outer surface to inhibit corrosion of the conduit by formation fluid. Conduit 382 may include cladding on an inner surface of the conduit that is corrosion resistant to material 494 in the conduit. Cladding applied to conduit 382 may be a coating and/or a liner. If the conduit contains a metal salt, the inner surface of the conduit may include coating of nickel, or the conduit may be or include a liner of a corrosion resistant metal such as Alloy N. If the conduit contains a molten metal, the conduit may include a corrosion resistant metal liner or coating, and/or a ceramic coating (for example, a porcelain coating or fired enamel coating). In an embodiment, conduit 382 is a canister of 410 stainless steel with an outside diameter of about 6 cm. Conduit 382 may not need a thick wall because material 494 may provide internal pressure that inhibits deformation or crushing of the conduit due to external stresses.

[0723] FIG. 64 depicts an embodiment of the heater positioned in wellbore 490 of formation 492 with a portion of insulated conductor 410 and conduit 382 oriented substantially horizontally in the formation. Material 494 may provide a head in conduit 382 due to the pressure of the material. The pressure head may keep material 494 in conduit 382. The pressure head may also provide internal pressure that inhibits deformation or collapse of conduit 382 due to external stresses.

[0724] In some embodiments, two or more insulated conductors are placed in the conduit. In some embodiments, only one of the insulated conductors is energized. Should the energized conductor fail, one of the other conductors may be energized to maintain the material in a molten phase. The failed insulated conductor may be removed and/or replaced.

[0725] The conduit of the heater may be a ribbed conduit. The ribbed conduit may improve the heat transfer characteristics of the conduit as compared to a cylindrical conduit. FIG. 65 depicts a cross-sectional representation of ribbed conduit 496. FIG. 66 depicts a perspective view of a portion of ribbed conduit 496. Ribbed conduit 496 may include rings 498 and ribs 500. Rings 498 and ribs 500 may improve the heat transfer characteristics of ribbed conduit 496. In an embodiment, the cylinder of conduit has an inner diameter of about 5.1 cm and a wall thickness of about 0.57 cm. Rings 498 may be spaced about every 3.8 cm. Rings 498 may have a height of about 1.9 cm and a thickness of about 0.5 cm. Six ribs 500 may be spaced evenly about conduit 382. Ribs 500 may have a thickness of about 0.5 cm and a height of about 1.6 cm.

Other dimensions for the cylinder, rings and ribs may be used. Ribbed conduit 496 may be formed from two or more rolled pieces that are welded together to form the ribbed conduit. Other types of conduit with extra surface area to enhance heat transfer from the conduit to the formation may be used.

[0726] In some embodiments, the ribbed conduit may be used as the conduit of a conductor-in-conduit heater. For example, the conductor may be a 3.05 cm 410 stainless steel rod and the conduit has dimensions as described above. In other embodiments, the conductor is an insulated conductor and a fluid is positioned between the conductor and the ribbed conduit. The fluid may be a gas or liquid at operating temperatures of the insulated conductor.

[0727] In some embodiments, the heat source for the heater is not an insulated conductor. For example, the heat source may be hot fluid circulated through an inner conduit positioned in an outer conduit. The material may be positioned between the inner conduit and the outer conduit. Convection currents in the material may help to more evenly distribute heat to the formation and may inhibit or limit formation of a hot spot where insulation that limits heat transfer to the overburden ends. In some embodiments, the heat sources are downhole oxidizers. The material is placed between an outer conduit and an oxidizer conduit. The oxidizer conduit may be an exhaust conduit for the oxidizers or the oxidant conduit if the oxidizers are positioned in a u-shaped wellbore with exhaust gases exiting the formation through one of the legs of the u-shaped conduit. The material may help inhibit the formation of hot spots adjacent to the oxidizers of the oxidizer assembly.

[0728] The material to be heated by the insulated conductor may be placed in an open wellbore. FIG. 67 depicts material 494 in open wellbore 490 in formation 492 with insulated conductor 410 in the wellbore. In some embodiments, a gas (for example, nitrogen, carbon dioxide, and/or helium) is placed in wellbore 490 above material 494. The gas may inhibit oxidation or other chemical changes of material 494. The gas may inhibit vaporization of material 494.

[0729] Material 494 may have a melting point that is above the pyrolysis temperature of hydrocarbons in the formation. The melting point of material 494 may be above 375° C., above 400° C., or above 425° C. The insulated conductor may be energized to heat the formation. Heat from the insulated conductor may pyrolyze hydrocarbons in the formation. Adjacent the wellbore, the heat from insulated conductor 410 may result in coking that reduces the permeability and plugs the formation near wellbore 490. The plugged formation inhibits material 494 from leaking from wellbore 490 into formation 492 when the material is a liquid. In some embodiments, material 494 is a salt.

[0730] In some embodiments, material 494 leaking from wellbore 490 into formation 492 may be self-healing and/or self-sealing. Material 494 flowing away from wellbore 490 may travel until the temperature becomes less than the solidification temperature of the material. Temperature may drop rapidly a relatively small distance away from the heater used to maintain material 494 in a liquid state. The rapid drop off in temperature may result in migrating material 494 solidifying close to wellbore 490. Solidified material 494 may inhibit migration of additional material from wellbore 490, and thus self-heal and/or self-seal the wellbore.

[0731] Return electrical current for insulated conductor 410 may return through jacket 370 of the insulated conductor. Any current that passes through material 494 may pass to

ground. Above the level of material 494, any remaining return electrical current may be confined to jacket 370 of insulated conductor 410.

[0732] Using liquid material in open wellbores heated by heaters may allow for delivery of high power rates (for example, up to about 2000 W/m) to the formation with relatively low heater surface temperatures. Hot spot generation in the formation may be reduced or eliminated due to convection smoothing out the temperature profile along the length of the heater. Natural convection occurring in the wellbore may greatly enhance heat transfer from the heater to the formation. Also, the large gap between the formation and the heater may prevent thermal expansion of the formation from harming the heater.

[0733] In some embodiments, an 8" (20.3 cm) wellbore may be formed in the formation. In some embodiments, casing may be placed through all or a portion of the overburden. A 0.6 inch (1.5 cm) diameter insulated conductor heater may be placed in the wellbore. The wellbore may be filled with solid material (for example, solid particles of salt). A packer may be placed near an interface between the treatment area and the overburden. In some embodiments, a pass through conduit in the packer may be included to allow for the addition of more material to the treatment area. A non-reactive or substantially non-reactive gas (for example, carbon dioxide and/or nitrogen) may be introduced into the wellbore. The insulated conductor may be energized to begin the heating that melts the solid material and heats the treatment area.

[0734] In some embodiments, other types of heat sources besides for insulated conductors are used to heat the material placed in the open wellbore. The other types of heat sources may include gas burners, pipes through which hot heat transfer fluid flows, or other types of heaters.

[0735] In some embodiments, heat pipes are placed in the formation. The heat pipes may reduce the number of active heat sources needed to heat a treatment area of a given size. The heat pipes may reduce the time needed to heat the treatment area of a given size to a desired average temperature. A heat pipe is a closed system that utilizes phase change of fluid in the heat pipe to transport heat applied to a first region to a second region remote from the first region. The phase change of the fluid allows for large heat transfer rates. Heat may be applied to the first region of the heat pipes from any type of heat source, including but not limited to, electric heaters, oxidizers, heat provided from geothermal sources, and/or heat provided from nuclear reactors.

[0736] Heat pipes are passive heat transport systems that include no moving parts. Heat pipes may be positioned in near horizontal to vertical configurations. The fluid used in heat pipes for heating the formation may have a low cost, a low melting temperature, a boiling temperature that is not too high (for example, generally below about 900° C.), a low viscosity at temperatures below about 540° C., a high heat of vaporization, and a low corrosion rate for the heat pipe material. In some embodiments, the heat pipe includes a liner of material that is resistant to corrosion by the fluid. TABLE 1 shows melting and boiling temperatures for several materials that may be used as the fluid in heat pipes. Other salts that may be used include, but are not limited to LiNO₃, and eutectic mixtures such as 53% by weight KNO₃; 40% by weight NaNO₃ and 7% by weight NaNO₂; 45.5% by weight KNO₃ and 54.5% by weight NaNO₂; or 50% by weight NaCl and 50% by weight SrCl₂.

[0737] FIG. 68 depicts schematic cross-sectional representation of a portion of a formation with heat pipes 502 positioned adjacent to a substantially horizontal portion of heat source 202. Heat source 202 is placed in a wellbore in the formation. Heat source 202 may be a gas burner assembly, an electrical heater, a leg of a circulation system that circulates hot fluid through the formation, or other type of heat source. Heat pipes 502 may be placed in the formation so that distal ends of the heat pipes are near or contact heat source 202. In some embodiments, heat pipes 502 mechanically attach to heat source 202. Heat pipes 502 may be spaced a desired distance apart. In an embodiment, heat pipes 502 are spaced apart by about 40 feet. In other embodiments, large or smaller spacings are used. Heat pipes 502 may be placed in a regular pattern with each heat pipe spaced a given distance from the next heat pipe. In some embodiments, heat pipes 502 are placed in an irregular pattern. An irregular pattern may be used to provide a greater amount of heat to a selected portion or portions of the formation. Heat pipes 502 may be vertically positioned in the formation. In some embodiments, heat pipes 502 are placed at an angle in the formation.

[0738] Heat pipes 502 may include sealed conduit 504, seal 506, liquid heat transfer fluid 508 and vaporized heat transfer fluid 510. In some embodiments, heat pipes 502 include metal mesh or wicking material that increases the surface area for condensation and/or promotes flow of the heat transfer fluid in the heat pipe. Conduit 504 may have first portion 512 and second portion 514. Liquid heat transfer fluid 508 may be in first portion 512. Heat source 202 external to heat pipe 502 supplies heat that vaporizes liquid heat transfer fluid 508. Vaporized heat transfer fluid 510 diffuses into second portion 514. Vaporized heat transfer fluid 510 condenses in second portion and transfers heat to conduit 504, which in turn transfers heat to the formation. The condensed liquid heat transfer fluid 508 flows by gravity to first portion 512.

[0739] Position of seal 506 is a factor in determining the effective length of heat pipe 502. The effective length of heat pipe 502 may also depend on the physical properties of the heat transfer fluid and the cross-sectional area of conduit 504. Enough heat transfer fluid may be placed in conduit 504 so that some liquid heat transfer fluid 508 is present in first portion 512 at all times.

[0740] Seal 506 may provide a top seal for conduit 504. In some embodiments, conduit 504 is purged with nitrogen, helium or other fluid prior to being loaded with heat transfer fluid and sealed. In some embodiments, a vacuum may be drawn on conduit 504 to evacuate the conduit before the conduit is sealed. Drawing a vacuum on conduit 504 before sealing the conduit may enhance vapor diffusion throughout the conduit. In some embodiments, an oxygen getter may be introduced in conduit 504 to react with any oxygen present in the conduit.

[0741] FIG. 69 depicts a perspective cut-out representation of a portion of a heat pipe embodiment with heat pipe 502 located radially around oxidizer assembly 516. Oxidizers 518 of oxidizer assembly 516 are positioned adjacent to first portion 512 of heat pipe 502. Fuel may be supplied to oxidizers 518 through fuel conduit 520. Oxidant may be supplied to oxidizers 518 through oxidant conduit 522. Exhaust gas may flow through the space between outer conduit 524 and oxidant conduit 522. Oxidizers 518 combust fuel to provide heat that vaporizes liquid heat transfer fluid 508. Vaporized heat transfer fluid 510 rises in heat pipe 502 and condenses on walls of the heat pipe to transfer heat to sealed conduit 504. Exhaust

gas from oxidizers **518** provides heat along the length of sealed conduit **504**. The heat provided by the exhaust gas along the effective length of heat pipe **502** may increase convective heat transfer and/or reduce the lag time before significant heat is provided to the formation from the heat pipe along the effective length of the heat pipe.

[0742] FIG. 70 depicts a cross-sectional representation of an angled heat pipe embodiment with oxidizer assembly **516** located near a lowermost portion of heat pipe **502**. Fuel may be supplied to oxidizers **518** through fuel conduit **520**. Oxidant may be supplied to oxidizers **518** through oxidant conduit **522**. Exhaust gas may flow through the space between outer conduit **524** and oxidant conduit **522**.

[0743] FIG. 71 depicts a perspective cut-out representation of a portion of a heat pipe embodiment with oxidizer **518** located at the bottom of heat pipe **502**. Fuel may be supplied to oxidizer **518** through fuel conduit **520**. Oxidant may be supplied to oxidizer **518** through oxidant conduit **522**. Exhaust gas may flow through the space between the outer wall of heat pipe **502** and outer conduit **524**. Oxidizer **518** combusts fuel to provide heat that vaporizes liquid heat transfer fluid **508**. Vaporized heat transfer fluid **510** rises in heat pipe **502** and condenses on walls of the heat pipe to transfer heat to sealed conduit **504**. Exhaust gas from oxidizers **518** provides heat along the length of sealed conduit **504** and to outer conduit **524**. The heat provided by the exhaust gas along the effective length of heat pipe **502** may increase convective heat transfer and/or reduce the lag time before significant heat is provided to the formation from the heat pipe and oxidizer combination along the effective length of the heat pipe. FIG. 72 depicts a similar embodiment with heat pipe **502** positioned at an angle in the formation.

[0744] FIG. 73 depicts a perspective cut-out representation of a portion of a heat pipe embodiment with oxidizer **518** that produces flame zone adjacent to liquid heat transfer fluid **508** in the bottom of heat pipe **502**. Fuel may be supplied to oxidizer **518** through fuel conduit **520**. Oxidant may be supplied to oxidizer **518** through oxidant conduit **522**. Oxidant and fuel are mixed and combusted to produce flame zone **526**. Flame zone **526** provides heat that vaporizes liquid heat transfer fluid **508**. Exhaust gases from oxidizer **518** may flow through the space between oxidant conduit **522** and the inner surface of heat pipe **502**, and through the space between the outer surface of the heat pipe and outer conduit **524**. The heat provided by the exhaust gas along the effective length of heat pipe **502** may increase convective heat transfer and/or reduce the lag time before significant heat is provided to the formation from the heat pipe and oxidizer combination along the effective length of the heat pipe.

[0745] FIG. 74 depicts a perspective cut-out representation of a portion of a heat pipe embodiment with a tapered bottom that accommodates multiple oxidizers of an oxidizer assembly. In some embodiments, efficient heat pipe operation requires a high heat input. Multiple oxidizers of oxidizer assembly **516** may provide high heat input to liquid heat transfer fluid **508** of heat pipe **502**. A portion of oxidizer assembly with the oxidizers may be helically wound around a tapered portion of heat pipe **502**. The tapered portion may have a large surface area to accommodate the oxidizers. Fuel may be supplied to the oxidizers of oxidizer assembly **516** through fuel conduit **520**. Oxidant may be supplied to oxidizer **518** through oxidant conduit **522**. Exhaust gas may flow through the space between the outer wall of heat pipe **502** and outer conduit **524**. Exhaust gas from oxidizers **518** provides

heat along the length of sealed conduit **504** and to outer conduit **524**. The heat provided by the exhaust gas along the effective length of heat pipe **502** may increase convective heat transfer and/or reduce the lag time before significant heat is provided to the formation from the heat pipe and oxidizer combination along the effective length of the heat pipe.

[0746] FIG. 75 depicts a cross-sectional representation of a heat pipe embodiment that is angled within the formation. First wellbore **528** and second wellbore **530** are drilled in the formation using magnetic ranging or techniques so that the first wellbore intersects the second wellbore. Heat pipe **502** may be positioned in first wellbore **528**. First wellbore **528** may be sloped so that liquid heat transfer fluid **508** within heat pipe **502** is positioned near the intersection of the first wellbore and second wellbore **530**. Oxidizer assembly **516** may be positioned in second wellbore **530**. Oxidizer assembly **516** provides heat to heat pipe **502** that vaporizes liquid heat transfer fluid in the heat pipe. Packer or seal **532** may direct exhaust gas from oxidizer assembly **516** through first wellbore **528** to provide additional heat to the formation from the exhaust gas.

[0747] In some embodiments, the temperature limited heater is used to achieve lower temperature heating (for example, for heating fluids in a production well, heating a surface pipeline, or reducing the viscosity of fluids in a wellbore or near wellbore region). Varying the ferromagnetic materials of the temperature limited heater allows for lower temperature heating. In some embodiments, the ferromagnetic conductor is made of material with a lower Curie temperature than that of 446 stainless steel. For example, the ferromagnetic conductor may be an alloy of iron and nickel. The alloy may have between 30% by weight and 42% by weight nickel with the rest being iron. In one embodiment, the alloy is Invar 36. Invar 36 is 36% by weight nickel in iron and has a Curie temperature of 277° C. In some embodiments, an alloy is a three component alloy with, for example, chromium, nickel, and iron. For example, an alloy may have 6% by weight chromium, 42% by weight nickel, and 52% by weight iron. A 2.5 cm diameter rod of Invar 36 has a turndown ratio of approximately 2 to 1 at the Curie temperature. Placing the Invar 36 alloy over a copper core may allow for a smaller rod diameter. A copper core may result in a high turndown ratio. The insulator in lower temperature heater embodiments may be made of a high performance polymer insulator (such as PFA or PEEK™) when used with alloys with a Curie temperature that is below the melting point or softening point of the polymer insulator.

[0748] In certain embodiments, a conductor-in-conduit temperature limited heater is used in lower temperature applications by using lower Curie temperature and/or the phase transformation temperature range ferromagnetic materials. For example, a lower Curie temperature and/or the phase transformation temperature range ferromagnetic material may be used for heating inside sucker pump rods. Heating sucker pump rods may be useful to lower the viscosity of fluids in the sucker pump or rod and/or to maintain a lower viscosity of fluids in the sucker pump rod. Lowering the viscosity of the oil may inhibit sticking of a pump used to pump the fluids. Fluids in the sucker pump rod may be heated up to temperatures less than about 250° C. or less than about 300° C. Temperatures need to be maintained below these values to inhibit coking of hydrocarbon fluids in the sucker pump system.

[0749] In certain embodiments, a temperature limited heater includes a flexible cable (for example, a furnace cable) as the inner conductor. For example, the inner conductor may be a 27% nickel-clad or stainless steel-clad stranded copper wire with four layers of mica tape surrounded by a layer of ceramic and/or mineral fiber (for example, alumina fiber, aluminosilicate fiber, borosilicate fiber, or aluminoborosilicate fiber). A stainless steel-clad stranded copper wire furnace cable may be available from Anomet Products, Inc. The inner conductor may be rated for applications at temperatures of 1000° C. or higher. The inner conductor may be pulled inside a conduit. The conduit may be a ferromagnetic conduit (for example, a ¾" Schedule 80 446 stainless steel pipe). The conduit may be covered with a layer of copper, or other electrical conductor, with a thickness of about 0.3 cm or any other suitable thickness. The assembly may be placed inside a support conduit (for example, a 1¼" Schedule 80 347H or 347HH stainless steel tubular). The support conduit may provide additional creep-rupture strength and protection for the copper and the inner conductor. For uses at temperatures greater than about 1000° C., the inner copper conductor may be plated with a more corrosion resistant alloy (for example, Incoloy® 825) to inhibit oxidation. In some embodiments, the top of the temperature limited heater is sealed to inhibit air from contacting the inner conductor.

[0750] FIG. 76 depicts an embodiment of three heaters coupled in a three-phase configuration. Conductor "legs" 534, 536, 538 are coupled to three-phase transformer 414. Transformer 414 may be an isolated three-phase transformer. In certain embodiments, transformer 414 provides three-phase output in a wye configuration. Input to transformer 414 may be made in any input configuration, such as the shown delta configuration. Legs 534, 536, 538 each include lead-in conductors 540 in the overburden of the formation coupled to heating elements 542 in hydrocarbon layer 388. Lead-in conductors 540 include copper with an insulation layer. For example, lead-in conductors 540 may be a 4-0 copper cables with TEFLON® insulation, a copper rod with polyurethane insulation, or other metal conductors such as bare copper or aluminum. In certain embodiments, lead-in conductors 540 are located in an overburden portion of the formation. The overburden portion may include overburden casings 398. Heating elements 542 may be temperature limited heater heating elements. In an embodiment, heating elements 542 are 410 stainless steel rods (for example, 3.1 cm diameter 410 stainless steel rods). In some embodiments, heating elements 542 are composite temperature limited heater heating elements (for example, 347 stainless steel, 410 stainless steel, copper composite heating elements; 347 stainless steel, iron, copper composite heating elements; or 410 stainless steel and copper composite heating elements). In certain embodiments, heating elements 542 have a length of about 10 m to about 2000 m, about 20 m to about 400 m, or about 30 m to about 300 m.

[0751] In certain embodiments, heating elements 542 are exposed to hydrocarbon layer 388 and fluids from the hydrocarbon layer. Thus, heating elements 542 are "bare metal" or "exposed metal" heating elements. Heating elements 542 may be made from a material that has an acceptable sulfidation rate at high temperatures used for pyrolyzing hydrocarbons. In certain embodiments, heating elements 542 are made from material that has a sulfidation rate that decreases with increasing temperature over at least a certain temperature range (for example, 500° C. to 650° C., 530° C. to 650° C., or

550° C. to 650° C.). For example, 410 stainless steel may have a sulfidation rate that decreases with increasing temperature between 530° C. and 650° C. Using such materials reduces corrosion problems due to sulfur-containing gases (such as H₂S) from the formation. In certain embodiments, heating elements 542 are made from material that has a sulfidation rate below a selected value in a temperature range. In some embodiments, heating elements 542 are made from material that has a sulfidation rate at most about 25 mils per year at a temperature between about 800° C. and about 880° C. In some embodiments, the sulfidation rate is at most about 35 mils per year at a temperature between about 800° C. and about 880° C., at most about 45 mils per year at a temperature between about 800° C. and about 880° C., or at most about 55 mils per year at a temperature between about 800° C. and about 880° C. Heating elements 542 may also be substantially inert to galvanic corrosion.

[0752] In some embodiments, heating elements 542 have a thin electrically insulating layer such as aluminum oxide or thermal spray coated aluminum oxide. In some embodiments, the thin electrically insulating layer is a ceramic composition such as an enamel coating. Enamel coatings include, but are not limited to, high temperature porcelain enamels. High temperature porcelain enamels may include silicon dioxide, boron oxide, alumina, and alkaline earth oxides (CaO or MgO), and minor amounts of alkali oxides (Na₂O, K₂O, LiO). The enamel coating may be applied as a finely ground slurry by dipping the heating element into the slurry or spray coating the heating element with the slurry. The coated heating element is then heated in a furnace until the glass transition temperature is reached so that the slurry spreads over the surface of the heating element and makes the porcelain enamel coating. The porcelain enamel coating contracts when cooled below the glass transition temperature so that the coating is in compression. Thus, when the coating is heated during operation of the heater, the coating is able to expand with the heater without cracking.

[0753] The thin electrically insulating layer has low thermal impedance allowing heat transfer from the heating element to the formation while inhibiting current leakage between heating elements in adjacent openings and/or current leakage into the formation. In certain embodiments, the thin electrically insulating layer is stable at temperatures above at least 350° C., above 500° C., or above 800° C. In certain embodiments, the thin electrically insulating layer has an emissivity of at least 0.7, at least 0.8, or at least 0.9. Using the thin electrically insulating layer may allow for long heater lengths in the formation with low current leakage.

[0754] Heating elements 542 may be coupled to contacting elements 544 at or near the underburden of the formation. Contacting elements 544 are copper or aluminum rods or other highly conductive materials. In certain embodiments, transition sections 546 are located between lead-in conductors 540 and heating elements 542, and/or between heating elements 542 and contacting elements 544. Transition sections 546 may be made of a conductive material that is corrosion resistant such as 347 stainless steel over a copper core. In certain embodiments, transition sections 546 are made of materials that electrically couple lead-in conductors 540 and heating elements 542 while providing little or no heat output. Thus, transition sections 546 help to inhibit overheating of conductors and insulation used in lead-in conductors 540 by spacing the lead-in conductors from heating elements 542.

Transition section **546** may have a length of between about 3 m and about 9 m (for example, about 6 m).

[0755] Contacting elements **544** are coupled to contactor **548** in contacting section **550** to electrically couple legs **534**, **536**, **538** to each other. In some embodiments, contact solution **552** (for example, conductive cement) is placed in contacting section **550** to electrically couple contacting elements **544** in the contacting section. In certain embodiments, legs **534**, **536**, **538** are substantially parallel in hydrocarbon layer **388** and leg **534** continues substantially vertically into contacting section **550**. The other two legs **536**, **538** are directed (for example, by directionally drilling the wellbores for the legs) to intercept leg **534** in contacting section **550**.

[0756] Each leg **534**, **536**, **538** may be one leg of a three-phase heater embodiment so that the legs are substantially electrically isolated from other heaters in the formation and are substantially electrically isolated from the formation. Legs **534**, **536**, **538** may be arranged in a triangular pattern so that the three legs form a triangular shaped three-phase heater. In an embodiment, legs **534**, **536**, **538** are arranged in a triangular pattern with 12 m spacing between the legs (each side of the triangle has a length of 12 m).

[0757] FIG. 77 depicts a side view representation of an embodiment of a substantially u-shaped three-phase heater. First ends of legs **534**, **536**, **538** are coupled to transformer **414** at first location **554**. In an embodiment, transformer **414** is a three-phase AC transformer. Ends of legs **534**, **536**, **538** are electrically coupled together with connector **556** at second location **558**. Connector **556** electrically couples the ends of legs **534**, **536**, **538** so that the legs can be operated in a three-phase configuration. In certain embodiments, legs **534**, **536**, **538** are coupled to operate in a three-phase wye configuration. In certain embodiments, legs **534**, **536**, **538** are substantially parallel in hydrocarbon layer **388**. In certain embodiments, legs **534**, **536**, **538** are arranged in a triangular pattern in hydrocarbon layer **388**. In certain embodiments, heating elements **542** include thin electrically insulating material (such as a porcelain enamel coating) to inhibit current leakage from the heating elements. In certain embodiments, the thin electrically insulating layer allows for relatively long, substantially horizontal heater leg lengths in the hydrocarbon layer with a substantially u-shaped heater. In certain embodiments, legs **534**, **536**, **538** are electrically coupled so that the legs are substantially electrically isolated from other heaters in the formation and are substantially electrically isolated from the formation.

[0758] In certain embodiments, overburden casings (for example, overburden casings **398**, depicted in FIGS. 76 and 77) in overburden **400** include materials that inhibit ferromagnetic effects in the casings. Inhibiting ferromagnetic effects in casings **398** reduces heat losses to the overburden. In some embodiments, casings **398** may include non-metallic materials such as fiberglass, polyvinylchloride (PVC), chlorinated polyvinylchloride (CPVC), or high-density polyethylene (HDPE). HDPEs with working temperatures in a range for use in overburden **400** include HDPEs available from Dow Chemical Co., Inc. (Midland, Mich., U.S.A.). A non-metallic casing may also eliminate the need for an insulated overburden conductor. In some embodiments, casings **398** include carbon steel coupled on the inside diameter of a non-ferromagnetic metal (for example, carbon steel clad with copper or aluminum) to inhibit ferromagnetic effects or inductive effects in the carbon steel. Other non-ferromagnetic metals include, but are not limited to, manganese steels with at least

10% by weight manganese, iron aluminum alloys with at least 18% by weight aluminum, and austenitic stainless steels such as 304 stainless steel or 316 stainless steel.

[0759] In certain embodiments, one or more non-ferromagnetic materials used in casings **398** are used in a wellhead coupled to the casings and legs **534**, **536**, **538**. Using non-ferromagnetic materials in the wellhead inhibits undesirable heating of components in the wellhead. In some embodiments, a purge gas (for example, carbon dioxide, nitrogen or argon) is introduced into the wellhead and/or inside of casings **398** to inhibit reflux of heated gases into the wellhead and/or the casings.

[0760] In certain embodiments, one or more of legs **534**, **536**, **538** are installed in the formation using coiled tubing. In certain embodiments, coiled tubing is installed in the formation, the leg is installed inside the coiled tubing, and the coiled tubing is pulled out of the formation to leave the leg installed in the formation. The leg may be placed concentrically inside the coiled tubing. In some embodiments, coiled tubing with the leg inside the coiled tubing is installed in the formation and the coiled tubing is removed from the formation to leave the leg installed in the formation. The coiled tubing may extend only to a junction of the hydrocarbon layer and the contacting section, or to a point at which the leg begins to bend in the contacting section.

[0761] FIG. 78 depicts a top view representation of an embodiment of a plurality of triads of three-phase heaters in the formation. Each triad **560** includes legs A, B, C (which may correspond to legs **534**, **536**, **538** depicted in FIGS. 76 and 77) that are electrically coupled by linkages **562**. Each triad **560** is coupled to its own electrically isolated three-phase transformer so that the triads are substantially electrically isolated from each other. Electrically isolating the triads inhibits net current flow between triads.

[0762] The phases of each triad **560** may be arranged so that legs A, B, C correspond between triads as shown in FIG. 78. Legs A, B, C are arranged such that a phase leg (for example, leg A) in a given triad is about two triad heights from a same phase leg (leg A) in an adjacent triad. The triad height is the distance from a vertex of the triad to a midpoint of the line intersecting the other two vertices of the triad. In certain embodiments, the phases of triads **560** are arranged to inhibit net current flow between individual triads. There may be some leakage of current within an individual triad but little net current flows between two triads due to the substantial electrical isolation of the triads and, in certain embodiments, the arrangement of the triad phases.

[0763] In the early stages of heating, an exposed heating element (for example, heating element **542** depicted in FIGS. 76 and 77) may leak some current to water or other fluids that are electrically conductive in the formation so that the formation itself is heated. After water or other electrically conductive fluids are removed from the wellbore (for example, vaporized or produced), the heating elements become electrically isolated from the formation. Later, when water is removed from the formation, the formation becomes even more electrically resistant and heating of the formation occurs even more predominantly via thermally conductive and/or radiative heating. Typically, the formation (the hydrocarbon layer) has an initial electrical resistance that averages at least 10 ohm·m. In some embodiments, the formation has an initial electrical resistance of at least 100 ohm·m or of at least 300 ohm·m.

[0764] Using the temperature limited heaters as the heating elements limits the effect of water saturation on heater efficiency. With water in the formation and in heater wellbores, there is a tendency for electrical current to flow between heater elements at the top of the hydrocarbon layer where the voltage is highest and cause uneven heating in the hydrocarbon layer. This effect is inhibited with temperature limited heaters because the temperature limited heaters reduce localized overheating in the heating elements and in the hydrocarbon layer.

[0765] In certain embodiments, production wells are placed at a location at which there is relatively little or zero voltage potential. This location minimizes stray potentials at the production well. Placing production wells at such locations improves the safety of the system and reduces or inhibits undesired heating of the production wells caused by electrical current flow in the production wells. FIG. 79 depicts a top view representation of the embodiment depicted in FIG. 78 with production wells 206. In certain embodiments, production wells 206 are located at or near center of triad 560. In certain embodiments, production wells 206 are placed at a location between triads at which there is relatively little or zero voltage potential (at a location at which voltage potentials from vertices of three triads average out to relatively little or zero voltage potential). For example, production well 206 may be at a location equidistant from leg A of one triad, leg B of a second triad, and leg C of a third triad, as shown in FIG. 79.

[0766] Certain embodiments of heaters include single-phase conductors in a single wellbore. For example, FIGS. 76 and 77 depict heater embodiments with three-phase heaters that include single-phase conductors in each wellbore. A problem with having a single-phase conductor in the wellbore is current or voltage induction in components of the wellbore (for example, the heater casing) and/or in the formation caused by magnetic fields produced by the single-phase conductor. In a wellbore with the supply and return conductors both located in the wellbore, the magnetic fields produced by the current running through the supply conductor are cancelled by magnetic fields produced by the current running through the return conductor. In addition, the single-phase conductor may induce currents in production wellbores and/or other nearby wellbores.

[0767] FIG. 80 depicts a schematic of an embodiment of a heat treatment system including heater 412 and production wells 206. In certain embodiments, heater 412 is a three-phase heater that includes legs 534, 536, 538 coupled to transformer 414 and terminal connector 556. Legs 534, 536, 538 may each include single-phase conductors. Legs 534, 536, 538 may be coupled together to form a triad heater. In certain embodiments, legs 534, 536, 538 are relatively long heater sections. For example, legs 534, 536, 538 may be about 3000 m or longer in length.

[0768] In some embodiments, as shown in FIG. 80, production wells 206 are located substantially horizontally in the formation and below legs 534, 536, 538 of heater 412. In some embodiments, production wells 206 are located at an incline or vertically in the formation. As shown in FIG. 80, production wells 206 may include two production wells that extend from each side of heater 412 towards the center of the heater substantially lengthwise along the heated sections of legs 534, 536, 538. In some embodiments, one production well 206 extends substantially lengthwise along the heated sections of the legs.

[0769] FIG. 81 depicts a side-view representation of one leg of heater 412 in the subsurface formation. Leg 534 is shown as representative of any leg in of heater 412 in the formation. Leg 534 may include heating element 542 in hydrocarbon layer 388 below overburden 400. In certain embodiments, heating element 542 is located substantially horizontal in hydrocarbon layer 388. Transition section 546 may couple heating element 542 to lead-in cable 540. Lead-in cable 540 may be an overburden section or overburden element of heater 412. Lead-in cable 540 couples heating element 542 and transition section 546 to electrical components at the surface (for example, transformer 414 and/or terminal connector 556 depicted in FIG. 80).

[0770] As shown in FIG. 81, heater casing 564 extends from the surface to at or near end of transition section 546. Overburden casing 398 substantially surrounds heater casing 564 in overburden 400. Surface conductor 566 substantially surrounds overburden casing 398 at or near the surface of the formation.

[0771] In certain embodiments, heating element 542 is an exposed metal or bare metal heating element. For example, heating element 542 may be an exposed ferromagnetic metal heating element such as 410 stainless steel. Lead-in cable 540 includes low resistance electrical conductors such as copper or copper-cladded steel. Lead-in cable 540 may include electrical insulation or otherwise be electrically insulated from overburden 400 (for example, overburden casing 398 may include electrical insulation on an inside surface of the casing). Transition section 546 may include a combination of stainless steel and copper suitable for transition between heating element 542 and lead-in cable 540.

[0772] In some embodiments, heater casing 564 includes non-ferromagnetic stainless steel or another suitable material that has high hanging strength and is non-ferromagnetic. Overburden casing 398 and/or surface conductor 566 may include carbon steel or other suitable materials.

[0773] FIG. 82 depicts a schematic representation of a surface cabling configuration with a ground loop used for heater 412 and production well 206. In certain embodiments, ground loop 568 substantially surrounds legs 534, 536, 538 of heater 412, production well 206, and transformer 414. Power cable 394 may couple transformer 414 to legs 534, 536, 538 of heater 412. The center portion of power cable 394 coupled to center leg 536 may be put into loop 570. Loop 570 extends the center portion of power cable 394 to have approximately the same length as the portions of power cable 394 coupled to side legs 534, 538. Having each portion of power cable 394 approximately the same length inhibits creation of phase differences between the legs.

[0774] In certain embodiments, transformer 414 is coupled to ground loop 568 to ground the transformer and heater 412. In some embodiments, production well 206 is coupled to ground loop 568 to ground the production well.

[0775] FIG. 83 depicts a side view of an overburden portion of leg 534. Lead-in cable 540 is substantially surrounded by heater casing 564 and overburden casing 398 ("casing 564/398") in the overburden of the formation. Current flow in lead-in cable 540 (represented by +/- symbols at ends the lead-in cable) induces current flow with opposite polarity on casing 564/398 (represented by +/- symbols on line 572). This induced voltage on casing 564/398 is caused by mutual inductance of the casing with all the heater elements in the

triad (each of the three-phase elements in the formation). The mutual inductance may be described by the following equation:

$$M=2\times 10^{-07} \ln[S/r]; \quad (\text{EQN. 6})$$

where M is the mutual inductance, S is the center to center separation between heater elements, and r is the outer radius of the casing. The induced voltage in the casing (V) is proportional to the current (I) and is given by the equation:

$$\Delta V=\omega MI. \quad (\text{EQN. 7})$$

[0776] Because typically high power is provided through lead-in cable 540 in order to provide power to long heater elements, the induced voltages and currents on casing 564/398 can be relatively high. Large induced currents on the casing may lead to AC corrosion problems and/or leakage of current into the formation. Large currents on the casing, when grounded, may also necessitate large currents in the ground loop to compensate for the currents on the casing. Large currents on the ground loop may be costly and, in some cases, be difficult or unsafe to operate. Large currents on the casing may also lead to high surface potentials around the heaters on the surface. High surface potentials may create unsafe areas for personnel and/or equipment on the surface.

[0777] Simulations may be used to assess and/or determine the location and magnitude of induced casing and ground currents in the formation. For example, simulation systems available from Safe Engineering Services & Technologies, Ltd. (Laval, Quebec, Canada) may be used to assess induced casing and ground currents for subsurface heating systems. Data such as, but not limited to, physical dimensions of the heaters, electrical and magnetic properties of materials used, formation resistivity profile, and applied voltage/current including phase profile may be used in the simulation to assess induced casing and ground currents.

[0778] FIG. 84 depicts a side view of overburden portions of legs 534, 536 grounded to ground loop 568. Legs 534, 536 have opposite polarity such that the currents induced in the casings of the legs also have opposite polarity. The opposite polarity of the casings causes circular current flow between the legs through the overburden. This circular current flow is represented by curve 574. Because legs 534, 536 are grounded to ground loop 568, the magnitude of circular current flow (curve 574) (current density on the casings) is relatively large. For example, current densities in the heater casing may be 1 A/m² or greater. Such current densities may increase the risk of AC corrosion in the heater casing.

[0779] FIG. 85 depicts a side view of overburden portions of legs 534, 536 with the legs grounded to a ground loop. Ungrounding legs 534, 536 reduces the magnitude of the circular current flow between the legs (current density on the casings), as shown by curve 574. For example, the current density on the heater casing may be lowered by a factor of about 2. This reduction in magnitude may, however, not be large enough to satisfy regulatory and/or safety issues with the induced current as the induced current remains near the surface of the formation. In addition, there may be additional regulatory and/or safety issues associated with ungrounding legs 534, 536 such as, but not limited to, increasing wellhead electrical fields above safe levels.

[0780] FIG. 86 depicts a side view of overburden portions of legs 534, 536 with the electrically conductive portions of casings 564/398 lowered selected depth 576 below the surface. As shown by curve 574, lowering the conductive portion of casings 564/398 selected depth 576 reduces the magnitude

of the induced current (current density on the casings) and moves the induced current to the selected depth below the surface. Moving the induced current to selected depth 576 below the surface reduces surface potentials and ground currents from the induced currents in the casings. For example, the current density on the heater casing may be lowered by a factor of about 3 by lowering the conductive portion of the casing.

[0781] In certain embodiments, the conductive portions of casings 564/398 are lowered in the formation by using electrically non-conductive materials in the portions of the casings above the conductive portions of the casings. For example, casings 564/398 may include non-conductive portions between the surface and the selected depth and conductive portions below the selected depth. In some embodiments, the electrically non-conductive portions include materials such as, but not limited to, fiberglass or other electrically insulating materials.

[0782] The non-conductive portion of casing 564/398 may only be used to the selected depth because the use of the non-conductive material may not be feasible. The non-conductive material may have low temperature limits that inhibits use of the non-conductive material near the heated section of the heater. Thus, conductive material may need to be used in the lower part of the overburden portion of the heater (the part near the heated section). As the non-conductive material may not be high strength material, to support the weight of the conductive material (for example, stainless steel), the conductive portion may be located as close to the surface as possible. Locating the conductive portion closer to the surface reduces the size of hanging devices or other structures that may be used to support the conductive portion of the casing.

[0783] In certain embodiments, the non-conductive portion of casing 564/398 extends to a depth that is below the surface moisture zone in the formation. Keeping the conductive portion of casing 564/398 below the surface moisture zone inhibits induced currents from reaching the surface.

[0784] In some embodiments, the non-conductive portion of casing 564/398 extends to a depth that is at least the distance between legs 534, 536. For example, for a 40' (about 12 m) spacing between legs, the non-conductive portion of casing 564/398 may extend at least about 100' (about 30 m) below the surface. In some embodiments, the non-conductive portion of casing 564/398 extends at least about 15 m, at least about 20 m, or at least about 30 m below the surface. The non-conductive portion of casing 564/398 may extend to a depth of at most about 150 m, about 300 m, or about 500 m from the surface.

[0785] The non-conductive portion of casing 564/398 may extend at most to a selected distance from the heated zone of the formation (the heated portion of the heater). In some embodiments, the selected distance is about 100 m, about 150 m, or about 200 m. In some embodiments, the non-conductive portion of casing 564/398 may extend to a depth that is slightly above or near the beginning of the bend in a u-shaped heater.

[0786] The desired depth of non-conductive portion of casing 564/398 may be assessed based on electrical effects for the formation to be treated and/or electrical properties of the heaters to be used. Simulations, such as those available from Safe Engineering Services & Technologies, Ltd. (Laval, Quebec, Canada), may be used to assess the desired depth of the non-conductive portion of the casing. The desired depth may

also be affected by factors such as, but not limited to, safety issues, regulatory issues, and mechanical issues.

[0787] In some embodiments, the overburden portions of legs 534, 536 are moved closer together so that the non-conductive portion of casing 564/398 can be moved to a shallower depth. For example, the overburden portions of legs 534, 536 may be relatively close together while the heated portions of the legs diverge below the overburden to greater separation distances needed for desired heating the formation.

[0788] In certain embodiments, as depicted in FIG. 86, legs 534, 536 are ungrounded with the casings lowered the selected distance. In some embodiments, however, legs 534, 536 are grounded with the casings lowered the selected distance. The grounding or ungrounding of the legs may affect the selected depth to which the casings are lowered.

[0789] When the electrically conductive portions of casings 564/398 are lowered to selected depth 576, ground loop 568 may become the highest field gradient at the surface. In some embodiments, a ground wellbore may be located below the surface and coupled to ground loop 568 (for example, with an insulated conductor (cable)). Coupling ground loop 568 to the ground wellbore below the surface may reduce or eliminate the high field gradient at the surface. The ground wellbore may be at a depth specified, for example, by standard electrical grounding practices known in the art.

[0790] In some embodiments, a subsurface hydrocarbon containing formation may be treated by the in situ heat treatment process to produce mobilized and/or pyrolyzed products from the formation. In some embodiments, a subsurface heater may include two or more flexible cable conductors. The flexible cable conductors may be positioned in a tubular. In some embodiments, the flexible cable conductors are positioned between two tubulars. In certain embodiments, the flexible cable conductors are positioned around an exterior surface of a first tubular. The flexible cable conductors and the first tubular may be positioned in a second tubular. The first and second tubular may form a dual-walled wellbore liner. The flexible cable conductors inside the first and second tubular allows the wellbore liner to be operated as a liner heater.

[0791] In some embodiments, the heater includes a plurality of flexible cable conductors positioned between the first and second tubulars. In certain embodiments, the heater includes between 2 and 16, between 4 and 12, or between 6 and 9 flexible cables. In some embodiments, the flexible cable conductors are wound around the inner first tubular in a roughly spiral pattern (for example, a helical pattern). Flexible cables may be formed from single conductors (for example, single-phase conductors) or multiple conductors (for example, three-phase conductors). Installing the flexible cable conductors in the spiral pattern may produce a more uniform temperature profile and/or relieve mechanical stresses on the conductors. The more uniform temperature profile may increase heater life. Spiraled flexible cable conductors, positioned between two tubulars, may not have the same tendency to expand and contract apart, which may potentially cause eddy currents. Spiraled flexible cable conductors, positioned between two tubulars, may be more easily coiled on a large reel for shipment without the ends of the heaters becoming uneven in length.

[0792] In certain embodiments, the tubulars are coiled tubing tubulars. Integrating the flexible heating cable(s) in the first and second tubulars may allow for installation using a

coiled tubing spooler, straightener, and/or injector system (for example, a coiled tubing rig). For example, coiled tubing tubulars may be wound onto the tubing rig during or after construction of the heater and unwound from the tubing rig as the heater is installed into the subsurface formation. This type of installation method may not require additional time typically required to attach the heating cable to a pipe wall during a well intervention, reducing the overall workover cost. The tubing rig may be readily transported from the construction site to the heater installation site using methods known in the art or described herein. Use of the dual walled coiled tubing heating system may allow for retrieval of the system during initial operations.

[0793] In some embodiments, at least a portion of the flexible cables are in contact with the outer second tubular. FIG. 87 depicts a cross-sectional representation of heater 412 including nine single-phase flexible cable conductors 380 positioned between first tubular 578a and second tubular 578b. Forming the heater such that the flexible cable conductors are in contact with the second tubular 578b results in the flexible cables providing conductive heat transfer between the first tubular 578a and the second tubular. In such embodiments, conductive heat transfer functions as the primary method of heat transfer to second tubular 578b.

[0794] In some embodiments, the flexible cables are inhibited from contacting the outer second tubular. FIG. 88 depicts a cross-sectional representation of heater 412 including nine single-phase flexible cable conductors 380 positioned between first tubular 578a and second tubular 578b with spacers 580. Spacers 580 may be positioned between first tubular 578a and second tubular 578b. The spacers may function to maintain separation between the tubulars and inhibit the flexible cables from contacting second tubular 578b. In such embodiments, radiative heat transfer functions as the primary method of heat transfer to second tubular 578b.

[0795] In some embodiments, spacers 580 are formed from an insulating material. For example, spacers may be formed from a fibrous ceramic material such as Nextel™ 312 (3M Corporation, St. Paul, Minn., U.S.A.), mica tape, or glass fiber. Ceramic material may be made of alumina, alumina-silicate, alumina-borosilicate, silicon nitride, boron nitride, or other suitable high-temperature materials.

[0796] In some embodiments, heat transfer material (for example, heat transfer fluid) is located in the annulus between first tubular 578a and second tubular 578b. Heat transfer material may increase the efficiency of the heaters. Heat transfer material includes, but is not limited to, molten metal, molten salt, other heat conducting liquids, or heat conducting gases.

[0797] In some embodiments, the first and/or second tubulars include two or more openings. The openings may allow fluids to be moved upwards and/or downwards through the tubulars. For example, formation fluids may be produced through one of the openings inside the tubulars. Having the openings inside the tubulars may promote heat transfer and/or hydrocarbon accumulation for production assistance (out-flow assurance) or formation heating (in-flow assurance). In some embodiments, the use of spacers enhances flow assurance inside the openings by reducing heat losses to the formation and increasing heat transfer to fluids flowing through the openings.

[0798] In some embodiments, the heater includes two or more portions that function to heat at different power levels and, thus, heat at different temperatures. For example, higher

power levels and higher temperatures may be generated in portions adjacent the hydrocarbon containing layer. Lower power levels (for example, <5% of the higher power level) and lower temperatures may be generated in portions adjacent the overburden. In some embodiments, lower power level flexible cables are designed and made utilizing larger diameter and/or different alloys with lower volume resistivities and low-power-producing conductors as compared with the high power level conductors. In some embodiments, the power reduction in the overburden is accomplished by using a conductor with a Curie-temperature power-limiting inherent characteristic (for example, low temperature, temperature limiting characteristics).

[0799] Flexible cables may be formed from single conductors or multiple conductors. In some embodiments, the flexible cables used in the heater include single conductor flexible cables installed between the first and second tubulars (for example, as depicted in FIGS. 87 and 88). The flexible cables may be electrically connected in as single phase conductors or coupled together in groups of 3 in 3-phase configurations (for example, 3-phase wye configurations). The electrical connections may be completed by bonding two conductors and up to nine or more conductors together.

[0800] The single conductor flexible cables may be connected together (for example, bonded) at the un-powered end, creating a single phase heating system (two cables connected) and up to, for example, three, 3-phase heating systems (nine cables connected to three power sources). These connections may be located at the subterranean end of the heating system (for example, near the toe of a horizontal heater wellbore). At the powered connection of the heater, the single-phase cables may be connected to line-to-line voltage (for example, up to 4160 V) for heat generation. 3-phase heaters may be connected electrically on the surface using a 3-phase power transformer. Line-to-neutral voltage for these heaters may be up to about 2402 V ($V/\sqrt{3}$) since they are electrically connected at the un-powered subterranean end.

[0801] In some embodiments, the flexible cable used in the heater includes multiple conductor flexible cables installed between the first and second tubulars. For example, the flexible cable may include three multiple conductors configured to be provided power by a 3-phase transformer. FIG. 89 depicts a cross-sectional representation of heater 412 including nine multiple (in FIG. 89, each flexible cable includes three conductors) flexible cable conductors 380 positioned between first tubular 578a and second tubular 578b. FIG. 90 depicts a cross-sectional representation of heater 412 including nine multiple (in FIG. 90, each flexible cable includes three conductors) flexible cable conductors 380 positioned between first tubular 578a and second tubular 578b with spacers 580. Heater 412 depicted in FIG. 90 includes spacers 580. The multiple conductor flexible cables depicted in FIGS. 89 and 90 may be coupled together at the un-powered end (for example, bonded at the un-powered end). These connections may be located at the subterranean end of the heating system (for example, near the toe of a horizontal heater wellbore). Connecting the flexible cable conductors at the un-powered end may create electrically independent, individual heating systems that are powered, up to nine or more at a time, to reduce the heat-up time constant for the desired formation temperature or three at a time to maintain the desired formation temperature. The line to neutral voltage for these heaters may be up to about 2402 V ($4160/\sqrt{3}$) since they are connected at the un-powered subterranean end.

[0802] The liner heaters, depicted in FIGS. 87, 88, 89, and 90, may include built-in redundancy in either the single conductor or multiple conductor designs. By connecting the flexible cable heaters to a common node at the end of the heating system, the single conductor heating cables may be powered to by-pass a non-working flexible cable, creating a 3-phase or single phase heating system.

[0803] In some embodiments, the liner heater is installed in a wellbore. The heater may allow the heat generated to be primarily transferred by conduction, directly into the near well-bore interface. The heat generation system may be in intimate contact with the near wellbore interface such that the operating temperatures of the heating system may be reduced. Reducing operating temperatures of the heater may extend the expected lifetime of the heater. Lower operating temperatures resulting from integrating the electro-thermal heating system within the dual wall coiled tubular liner may increase the reliability of all components such as: a) outer sheath material; b) ceramic insulation; c) conductor(s) material; d) splices; and e) components. Reducing operating temperatures of the heater may inhibit hydrocarbon coking.

[0804] Because the liner heater is located in the liner portion of the wellbore, the use of a heating system in the interior of the wellbore may be eliminated. Eliminating the need for a heating system in the interior of the wellbore may allow for unobstructed heated oil production through the wellbore. Eliminating the need for a heating system in the interior of the wellbore may allow for the ability to introduce heated diluents or process-inducing additives to the formation through the interior of the wellbore.

[0805] In certain embodiments, portions of the wellbore that extend through the overburden include casings. The casings may include materials that inhibit inductive effects in the casings. Inhibiting inductive effects in the casings may inhibit induced currents in the casing and/or reduce heat losses to the overburden. In some embodiments, the overburden casings may include non-metallic materials such as fiberglass, polyvinylchloride (PVC), chlorinated PVC (CPVC), high-density polyethylene (HDPE), high temperature polymers (such as nitrogen based polymers), or other high temperature plastics. HDPEs with working temperatures in a usable range include HDPEs available from Dow Chemical Co., Inc. (Midland, Mich., U.S.A.). The overburden casings may be made of materials that are spoolable so that the overburden casings can be spooled into the wellbore. In some embodiments, overburden casings may include non-magnetic metals such as aluminum or non-magnetic alloys such as manganese steels having at least 10% manganese, iron aluminum alloys with at least 18% aluminum, or austenitic stainless steels such as 304 stainless steel or 316 stainless steel. In some embodiments, overburden casings may include carbon steel or other ferromagnetic material coupled on the inside diameter to a highly conductive non-ferromagnetic metal (for example, copper or aluminum) to inhibit inductive effects or skin effects. In some embodiments, overburden casings are made of inexpensive materials that may be left in the formation (sacrificial casings).

[0806] In certain embodiments, wellheads for the wellbores may be made of one or more non-ferromagnetic materials. FIG. 91 depicts an embodiment of wellhead 392. The components in the wellheads may include fiberglass, PVC, CPVC, HDPE, high temperature polymers (such as nitrogen based polymers), and/or non-magnetic alloys or metals. Some materials (such as polymers) may be extruded into a

mold or reaction injection molded (RIM) into the shape of the wellhead. Forming the wellhead from a mold may be a less expensive method of making the wellhead and save in capital costs for providing wellheads to a treatment site. Using non-ferromagnetic materials in the wellhead may inhibit undesired heating of components in the wellhead. Ferromagnetic materials used in the wellhead may be electrically and/or thermally insulated from other components of the wellhead. In some embodiments, an inert gas (for example, nitrogen or argon) is purged inside the wellhead and/or inside of casings to inhibit reflux of heated gases into the wellhead and/or the casings.

[0807] In some embodiments, ferromagnetic materials in the wellhead are electrically coupled to a non-ferromagnetic material (for example, copper) to inhibit skin effect heat generation in the ferromagnetic materials in the wellhead. The non-ferromagnetic material is in electrical contact with the ferromagnetic material so that current flows through the non-ferromagnetic material. In certain embodiments, as shown in FIG. 91, non-ferromagnetic material 582 is coupled (and electrically coupled) to the inside walls of conduit 382 and wellhead walls 584. In some embodiments, copper may be plasma sprayed, coated, clad, or lined on the inside and/or outside walls of the wellhead. In some embodiments, a non-ferromagnetic material such as copper is welded, brazed, clad, or otherwise electrically coupled to the inside and/or outside walls of the wellhead. For example, copper may be swaged out to line the inside walls in the wellhead. Copper may be liquid nitrogen cooled and then allowed to expand to contact and swage against the inside walls of the wellhead. In some embodiments, the copper is hydraulically expanded or explosively bonded to contact against the inside walls of the wellhead.

[0808] In some embodiments, two or more substantially horizontal wellbores are branched off of a first substantially vertical wellbore drilled downwards from a first location on a surface of the formation. The substantially horizontal wellbores may be substantially parallel through a hydrocarbon layer. The substantially horizontal wellbores may reconnect at a second substantially vertical wellbore drilled downwards at a second location on the surface of the formation. Having multiple wellbores branching off of a single substantially vertical wellbore drilled downwards from the surface reduces the number of openings made at the surface of the formation.

[0809] Typical temperature measurement methods may be difficult and/or expensive to implement for use in assessing a temperature profile of a heater located in a subsurface formation for heating in an in situ heat treatment process. The desire is for a temperature profile that includes multiple temperatures along the length or a portion of the heater in the subsurface formation. Thermocouples are one possible solution; however, thermocouples provide only one temperature at one location and one wire is generally needed for each thermocouple. Thus, to obtain a temperature profile along a length of the heater, multiple wires are needed. The risk of failure of one or more of the thermocouples (or their associated wires) is increased with the use of multiple wires in the subsurface wellbore.

[0810] Another possible solution is the use of a fiber optic cable temperature sensor system. The fiber optic cable system provides a temperature profile along a length of the heater. Commercially available fiber optic cable systems, however, typically only have operating temperature ranges up to about 300° C. Thus, these systems are not suitable for measurement

of higher temperatures encountered while heating the subsurface formation during the in situ heat treatment process. Some experimental fiber optic cable systems are suitable for use at these higher temperatures but these systems may be too expensive for implementation in a commercial process (for example, a large field of heaters). Thus, there is a need for a simple, inexpensive system that allows temperature assessment at one or more locations along a length of the subsurface heater used in the in situ heat treatment process.

[0811] Current techniques allow for the measurement of dielectric properties of insulation along a length of the insulation (measurement of dielectric properties distributed along the length of the insulation). These techniques provide a profile of the dielectric properties with a spatial resolution (space between measurements) based on the type of insulation and the abilities of the measurement system. These techniques are currently used to assess dielectric properties and detect insulation flaws and/or insulation damage. Examples of current techniques are axial tomography and line resonance analysis. A version of axial tomography (Mashikian Axial Tomography) is provided by Instrument Manufacturing Company (IMCORP)(Storrs, Conn., U.S.A.). Mashikian Axial Tomography is disclosed in U.S. Pat. Application Pub. No. 2008/0048668 to Mashikian, which is incorporated by reference as if fully set forth herein. A version of line resonance analysis (LIRA) is provided by Wirescan AS (Halden, Norway). Wirescan AS LIRA is disclosed in International Pat. Pub. No. WO 2007/040406 to Fantoni, which is incorporated by reference as if fully set forth herein.

[0812] The assessment of dielectric properties (using either the current techniques or modified versions of these techniques) may be used in combination with information about the temperature dependence of dielectric properties to assess a temperature profile of one or more energized heaters (heaters that are powered and providing heat). The temperature dependence data of the dielectric properties may be found from simulation and/or experimentation. Examples of dielectric properties of the insulation that may be assessed over time include, but are not limited to, dielectric constant and loss tangent. FIG. 92 depicts an example of a plot of dielectric constant versus temperature for magnesium oxide insulation in one embodiment of an insulated conductor heater. FIG. 93 depicts an example of a plot of loss tangent ($\tan \delta$) versus temperature for magnesium oxide insulation in one embodiment of an insulated conductor heater.

[0813] It should be noted that the temperature dependent behavior of a dielectric property may vary based on certain factors. Factors that may affect the temperature dependent behavior of the dielectric property include, but are not limited to, the type of insulation, the dimensions of the insulation, the time the insulation is exposed to environment (for example, heat from the heater), the composition (chemistry) of the insulation, and the compaction of the insulation. Thus, it is typically necessary to measure (either by simulation and/or experimentation) the temperature dependent behavior of the dielectric property for the embodiment of insulation that is to be used in a selected heater.

[0814] In certain embodiments, one or more dielectric properties of the insulation in a heater having electrical insulation are assessed (measured) and compared to temperature dependence data of the dielectric properties to assess (determine) a temperature profile along a length of the heater (for example, the entire length of the heater or a portion of the heater). For example, the temperature of an insulated conduc-

tor heater (such as a mineral insulated (MI) cable heater) may be assessed based on dielectric properties of the insulation used in the heater. Examples of insulated conductor heaters are depicted in FIGS. 32A, 32B, and 33. Since the temperature dependence of the dielectric property measured is known or estimated from simulation and/or experimentation, the measured dielectric property at a location along the heater may be used to assess the temperature of the heater at that location. Using techniques that measure the dielectric properties at multiple locations along a length of the heater (as is possible with current techniques), a temperature profile along that heater length may be provided.

[0815] In some embodiments, as shown by the plots in FIGS. 92 and 93, the dielectric properties are more sensitive to temperature at higher temperatures (for example, above about 900° F., as shown in FIGS. 92 and 93). Thus, in some embodiments, the temperature of a portion of the insulated conductor heater is assessed by measurement of the dielectric properties at temperatures above about 400° C. (about 760° F.). For example, the temperature of the portion may be assessed by measurement of the dielectric properties at temperatures ranging from about 400° C., about 450° C., or about 500° C. to about 800° C., about 850° C., or about 900° C. These ranges of temperatures are above temperatures that can be measured using commercially available fiber optic cable systems. A fiber optic cable system suitable for use in the higher temperature ranges may, however, provide measurements with higher spatial resolution than temperature assessment by measurement of the dielectric properties. Thus, in some embodiments, the fiber optic cable system operable in the higher temperature ranges may be used to calibrate temperature assessment by measurement of dielectric properties.

[0816] At temperatures below these temperature ranges (for example, below about 400° C.), temperature assessment by measurement of the dielectric properties may be less accurate. Temperature assessment by measurement of the dielectric properties may, however, provide a reasonable estimate or “average” temperature of portions of the heater. The average temperature assessment may be used to assess whether the heater is operating in a safe range. Typically, a heater operating at temperatures below about 400° C., below about 450° C., or below about 500° C. is operating in the safe range.

[0817] Temperature assessment by measurement of dielectric properties may provide a temperature profile along a length or portion of the insulated conductor heater (temperature measurements distributed along the length or portion of the heater). Measuring the temperature profile is more useful for monitoring and controlling the heater as compared to taking temperature measurements at only selected locations (such as temperature measurement with thermocouples). Multiple thermocouples may be used to provide a temperature profile. Multiple wires (one for each thermocouple), however, would be needed. Temperature assessment by measurement of dielectric properties uses only one wire for measurement of the temperature profile, which is simpler and less expensive than using multiple thermocouples. In some embodiments, one or more thermocouples placed at selected locations are used to calibrate temperature assessment by measurement of dielectric properties.

[0818] In certain embodiments, the dielectric properties of the insulation in an insulated conductor heater are assessed (measured) over a period of time to assess the temperature and operating characteristics of the heater over the period of time. For example, the dielectric properties may be assessed

continuously (or substantially continuously) to provide real-time monitoring of the dielectric properties and the temperature. Monitoring of the dielectric properties and the temperature may be used to assess the condition of the heater during operation of the heater. For example, comparison of the assessed properties at specific locations versus the average properties over the length of the heater may provide information on the location of hot spots or defects in the heater.

[0819] In some embodiments, the dielectric properties of the insulation change over time. For example, the dielectric properties may change over time because of changes in the oxygen concentration in the insulation over time and/or changes in the water content in the insulation over time. Oxygen in the insulation may be consumed by chromium or other metals used in the insulated conductor heater. Thus, the oxygen concentration decreases with time in the insulation and affects the dielectric properties of the insulation.

[0820] The changes in dielectric properties over time may be measured and compensated for through experimental and/or simulated data. For example, the insulated conductor heater to be used for temperature assessment may be heated in an oven or other apparatus and the changes in dielectric properties can be measured over time at various temperatures and/or at constant temperatures. In addition, thermocouples may be used to calibrate the assessment of dielectric properties changes over time by comparison of thermocouple data to temperature assessed by the dielectric properties.

[0821] In certain embodiments, temperature assessment by measurement of dielectric properties is performed using a computational system such as a workstation or computer. The computational system may receive measurements (assessments) of the dielectric properties along the heater and correlate these measured dielectric properties to assess temperatures at one or more locations on the heater. For example, the computational system may store data about the relationship of the dielectric properties to temperature (such as the data depicted in FIGS. 92 and 93) and/or time, and use this stored data to calculate the temperatures on the heater based on the measured dielectric properties.

[0822] In certain embodiments, temperature assessment by dielectric properties measurement is performed on an energized heater providing heat to the subsurface formation (for example, an insulated conductor heater provided with electric power to resistively heat and provide heat to the subsurface formation). Assessing temperature on the energized heater allows for detection of defects in the insulation on the device actually providing heat to the formation. Assessing temperature on the energized heater, however, may be more difficult due to attenuation of signal along the heater because the heater is resistively heating. This attenuation may inhibit seeing further along the length of the heater (deeper into the formation along the heater). In some embodiments, temperatures in the upper sections of heaters (sections of the heater closer to the overburden, for example, the upper half or upper third of the heater) may be more important for assessment because these sections have higher voltages applied to the heater, are at higher temperatures, and are at higher risk for failure or generation of hot spots. The signal attenuation in the temperature assessment by dielectric properties measurement may not be as significant a factor in these upper sections because of the proximity of these sections to the surface.

[0823] In some embodiments, power to the insulated conductor heater is turned off before performing the temperature assessment. Power is then returned to the insulated conductor

heater after the temperature assessment. Thus, the insulated conductor heater is subjected to a heating on/off cycle to assess temperature. This on/off cycle may, however, reduce the lifetime of the heater due to the thermal cycling. In addition, the heater may cool off during the non-energized time period and provide less accurate temperature information (less accurate information on the actual working temperature of the heater).

[0824] In certain embodiments, temperature assessment by dielectric properties measurement is performed on an insulated conductor that is not to be used for heating or not configured for heating. Such an insulated conductor may be a separate insulated conductor temperature probe. In some embodiments, the insulated conductor temperature probe is a non-energized heater (for example, an insulated conductor heater not powered). The insulated conductor temperature probe may be a stand-alone device that can be located in an opening in the subsurface formation to measure temperature in the opening. In some embodiments, the insulated conductor temperature probe is a looped probe that goes out and back into the opening with signals transmitted in one direction on the probe. In some embodiments, the insulated conductor temperature probe is a single hanging probe with the signal transmitted along the core and returned along the sheath of the insulated conductor.

[0825] In certain embodiments, the insulated conductor temperature probe includes a copper core (to provide better conductance to the end of the cable and better spatial resolution) surrounded by magnesium oxide insulation and an outer metal sheath. The outer metal sheath may be made of any material suitable for use in the subsurface opening. For example, the outer metal sheath may be a stainless steel sheath or an inner sheath of copper wrapped with an outer sheath of stainless steel. Typically, the insulated conductor temperature probe operates up to temperatures and pressures that can be withstood by the outer metal sheath.

[0826] In some embodiments, the insulated conductor temperature probe is located adjacent to or near an energized heater in the opening to measure temperatures along the energized heater. There may be a temperature difference between the insulated conductor temperature probe and the energized heater (for example, between about 50° C. and 100° C. temperature differences). This temperature difference may be assessed through experimentation and/or simulation and accounted for in the temperature measurements. The temperature difference may also be calibrated using one or more thermocouples attached to the energized heater.

[0827] In some embodiments, one or more thermocouples are attached to the insulated conductor used for temperature assessment (either an energized insulated conductor heater or a non-energized insulated conductor temperature probe). The attached thermocouples may be used for calibration and/or backup measurement of the temperature assessed on the insulated conductor by dielectric property measurement. In some embodiments, calibration and/or backup temperature indication is achieved by assessment of the resistance variation of the core of the insulated conductor at a given applied voltage. Temperature may be assessed by knowing the resistance versus temperature profile of the core material at the given voltage. In some embodiments, the insulated conductor is a loop and current induced in the loop from energized heaters in the subsurface opening provides input for the resistance measurement.

[0828] In certain embodiments, insulation material properties in the insulated conductor are varied to provide different sensitivities to temperature for the insulated conductor. Examples of insulation material properties that may be varied include, but are not limited to, the chemical and phase composition, the microstructure, and/or the mixture of insulating materials. Varying the insulation material properties in the insulated conductor allows the insulated conductor to be tuned to a selected temperature range. The selected temperature range may be selected, for example, for a desired application of the insulated conductor.

[0829] In some embodiments, insulation material properties are varied along the length of the insulated conductor (the insulation material properties are different at selected points within the insulated conductor). Varying properties of the insulation material at known locations along the length of the insulated conductor allows the measurement of the dielectric properties to give location information and/or provide for self-calibration of the insulated conductor in addition to providing temperature assessment. In some embodiments, the insulated conductor includes a portion with insulation material properties that allow the portion to act as a reflector. The reflector portion may be used to limit temperature assessment to specific portions of the insulated conductor (for example, a specific length of insulated conductor). One or more reflector portions may be used to provide spatial markers along the length of the insulated conductor.

[0830] Varying the insulation material properties adjusts the activation energy of the insulation material. Typically, increasing the activation energy of the insulation material reduces attenuation in the insulation material and provides better spatial resolution. Lowering the activation energy typically provides better temperature sensitivity. The activation energy may be raised or lowered, for example, by adding different components to the insulation material. For example, adding certain components to magnesium oxide insulation will lower the activation energy. Examples of components that may be added to magnesium oxide to lower the activation energy include, but are not limited to, titanium oxide, nickel oxide, and iron oxide.

[0831] In some embodiments, temperature is assessed using two or more insulated conductors. The insulated conductors may have different activation energies to provide a variation in spatial resolution and temperature sensitivity to more accurately assess temperature in the subsurface opening. The higher activation energy insulated conductor may be used to provide better spatial resolution and identify the location of hot spots or other temperature variations more accurately while the lower activation energy insulated conductor may be used to provide more accurate temperature measurement at those locations.

[0832] In some embodiments, temperature is assessed by assessing leakage current from the insulated conductor. Temperature dependence data of the leakage current may be used to assess the temperature based on assessed (measured) leakage current from the insulated conductor. The measured leakage current may be used in combination with information about the temperature dependence of the leakage current to assess a temperature profile of one or more heaters or insulated conductors located in a subsurface opening. The temperature dependence data of the leakage current may be found from simulation and/or experimentation. In certain embodiments, the temperature dependence data of the leakage current is also dependent on the voltage applied to the heater.

[0833] FIG. 94 depicts an example of a plot of leakage current (mA) versus temperature ($^{\circ}$ F.) for magnesium oxide insulation in one embodiment of an insulated conductor heater at different applied voltages. Plot 586 is for an applied voltage of 4300 V. Plot 588 is for an applied voltage of 3600 V. Plot 590 is for an applied voltage of 2800 V. Plot 592 is for an applied voltage of 2100 V.

[0834] As shown by the plots in FIG. 94, the leakage current is more sensitive to temperature at higher temperatures (for example, above about 950° F., as shown in FIG. 94). Thus, in some embodiments, the temperature of a portion of the insulated conductor heater is assessed by measurement of the leakage current at temperatures above about 500° C. (about 932° F.).

[0835] A temperature profile along a length of the heater may be obtained by measuring the leakage current along the length of the heater using techniques known in the art. In some embodiments, assessment of temperature by measuring the leakage current is used in combination with temperature assessment by dielectric properties measurement. For example, temperature assessment by measurement of the leakage current may be used to calibrate and/or backup temperature assessments made by measurement of dielectric properties.

[0836] In certain embodiments, an insulated conductor using salt as the electrical insulator is used for temperature measurement. The salt becomes an electrical conductor above the melting temperature (T_m) of the salt and allows current to flow through the electrical insulator. FIG. 95 depicts an embodiment of insulated conductor 410 with salt used as electrical insulator 364. Core 374 is copper or another suitable electrical conductor. Jacket 370 is stainless steel or another suitable corrosion-resistant electrical conductor. In one embodiment, core 374 is 0.125" (about 0.3175 cm) diameter copper surrounded by electrical insulator 364. Electrical insulator 364 is 0.1" (about 0.25 cm) thick salt insulation surrounded by jacket 370. Jacket 370 is 0.1" (about 0.25 cm) thick stainless steel. The outer diameter of insulated conductor 410 is then 0.525" (about 1.33 cm).

[0837] In certain embodiments, electrical insulator 364 includes a salt with a melting temperature (T_m) at a desired temperature. The desired temperature may be a temperature in the range of operation of a subsurface heater or a maximum temperature desired in the opening. For example, the desired temperature may be above about 300° C. or in a range between 300° C., 400° C., about 450° C., or about 500° C. and about 800° C., about 850° C., or about 900° C. Examples of salts include, but are not limited to, Na_2CO_3 ($T_m=851^{\circ}$ C.), Li_2CO_3 ($T_m=732^{\circ}$ C.), LiCl ($T_m=605^{\circ}$ C.), KOH ($T_m=420^{\circ}$ C.), KNO_3 ($T_m=334^{\circ}$ C.), NaNO_3 ($T_m=308^{\circ}$ C.), and mixtures thereof. In some embodiments, magnesium oxide (such as porous magnesium oxide) is added to the salt to provide mechanical centering support. The magnesium oxide maintains the integrity and structure of insulated conductor 410 when the salt melts. Porous magnesium oxide allows for electrical connectivity between core 374 and jacket 370 by having the salt distributed in the pores of the magnesium oxide.

[0838] In certain embodiments, a mixture of two or more salts is used in electrical insulator 364 of insulated conductor 410. Varying the composition of the salts in the mixture allows for adjusting and tuning the melting temperature of the mixture to a desired temperature. In some embodiments, the composition of eutectic mixtures of salts is adjusted and

tuned to the desired temperature. Eutectic mixtures may allow for finer adjustment and tuning to the desired temperature. Examples of eutectic mixtures that may be used include, but are not limited to, $\text{K}_2\text{CO}_3:\text{Na}_2\text{CO}_3:\text{Li}_2\text{CO}_3$ and $\text{KNO}_3:\text{NaNO}_3$.

[0839] Insulated conductor 410 may be coupled to or located near one or more heaters in a subsurface wellbore to assess the temperature at one or more locations along the length of the insulated conductor at or near the heaters. In some embodiments, insulated conductor 410 is similar in length to the heaters in the subsurface wellbore. In some embodiments, insulated conductor 410 has a shorter length than the heaters. In some embodiments, more than one insulated conductor 410 may be used in the wellbore to assess the temperature at different locations in the wellbore and/or at different temperatures.

[0840] FIG. 96 depicts an embodiment of insulated conductor 410 located proximate heaters 412 in wellbore 490. In some embodiments, insulated conductor 410 is coupled to one or more of heaters 412. For example, insulated conductor 410 may be strapped to the assembly of heaters 412. Heaters 412 may be insulated conductor heaters, conductor-in-conduit heaters, other types of heaters described herein, or combinations thereof.

[0841] To assess a location that is hotter than other portions of insulated conductor 410, voltage is applied to core 374 and jacket 370 of the insulated conductor, as shown in FIG. 97. Below the melting temperature (T_m) of the salt, there is little or no current drawn by core 374 and jacket 370 because the salt is in a solid phase. In the solid phase, the salt acts as an electrical insulator with resistivities above about $10^6 \Omega\text{-cm}$.

[0842] In some embodiments, hot spot 594 may develop at some location along the insulated conductor 410. Hot spot 594 is hotter than other portions along the length of insulated conductor 410. Hot spot 594 may be caused by a hot spot developing on or near one or more heaters located in the wellbore (for example, heaters 412 depicted in FIG. 96). At hot spot 594, the salt melts and becomes a liquid or molten salt. In the liquid phase, the salt becomes an electrical conductor with resistivities below $1 \Omega\text{-cm}$. Thus, current begins to flow between the surface and hot spot 594, as shown by the arrows in FIG. 97. Once current begins to flow through core 374 and jacket 370 of insulated conductor 410, if the resistance of the core and the jacket are known, the distance from the surface to hot spot 594 (x in FIG. 97) may be assessed by the measured current at the surface.

[0843] In certain embodiments, multiple hotspots may be located using insulated conductor 410. Time domain reflectometry may be used to locate multiple hotspots along insulated conductor 410 because the insulated conductor has a coaxial geometry. FIG. 98 shows insulated conductor 410 with multiple hot spots 594A, 594B. Incident pulse 596 is provided to insulated conductor 410. Reflected pulses 598A, 598B are generated at corresponding hot spots 594A, 594B.

[0844] The conductive molten salt at hot spots 594A, 594B provides a strong impedance mismatch for the reflections. The reflection coefficient for each hotspot can be assessed using EQN. 8:

$$\rho = (Z_{HS} - Z_0) / (Z_{HS} + Z_0); \quad (\text{EQN. 8})$$

[0845] where Z_{HS} is the impedance of the hotspot, and Z_0 is the impedance of the insulated conductor (cable).

[0846] The location of the hotspots (X_{HSa} , X_{HSb}) can be assessed by assessing (measuring) the transit time, τ , between the incident and reflected pulses and using EQN. 9:

$$X_{HS} = v \cdot \tau / 2; \quad (\text{EQN. 9})$$

[0847] where $v = v_c / \sqrt{\epsilon}$ is the propagation velocity, v_c is the speed of light, and ϵ is the dielectric constant of the salt insulation, which depends upon the salt used and compaction of the insulated conductor. In some embodiments, a hairpin insulated conductor configuration is used. The hairpin configuration allows for testing from both ends of the insulated conductor and increases the accuracy of hotspot location.

[0848] In some embodiments, assessment of the locations of hotspots by assessing the current or pulses applied to salt based insulated conductor **410** is used in combination with temperature assessment using thermocouples and/or fiber optic cable temperature sensor. The thermocouples and/or fiber optic cable temperature sensor may be used for calibration and/or backup measurement of the temperature assessment using the salt based insulated conductor.

[0849] In certain embodiments, a temperature limited heater is utilized for heavy oil applications (for example, treatment of relatively permeable formations or tar sands formations). A temperature limited heater may provide a relatively low Curie temperature and/or phase transformation temperature range so that a maximum average operating temperature of the heater is less than 350° C., 300° C., 250° C., 225° C., 200° C., or 150° C. In an embodiment (for example, for a tar sands formation), a maximum temperature of the temperature limited heater is less than about 250° C. to inhibit olefin generation and production of other cracked products. In some embodiments, a maximum temperature of the temperature limited heater is above about 250° C. to produce lighter hydrocarbon products. In some embodiments, the maximum temperature of the heater may be at or less than about 500° C.

[0850] A heater may heat a volume of formation adjacent to a production wellbore (a near production wellbore region) so that the temperature of fluid in the production wellbore and in the volume adjacent to the production wellbore is less than the temperature that causes degradation of the fluid. The heat source may be located in the production wellbore or near the production wellbore. In some embodiments, the heat source is a temperature limited heater. In some embodiments, two or more heat sources may supply heat to the volume. Heat from the heat source may reduce the viscosity of crude oil in or near the production wellbore. In some embodiments, heat from the heat source mobilizes fluids in or near the production wellbore and/or enhances the flow of fluids to the production wellbore. In some embodiments, reducing the viscosity of crude oil allows or enhances gas lifting of heavy oil (at most about 10° API gravity oil) or intermediate gravity oil (approximately 12° to 20° API gravity oil) from the production wellbore. In certain embodiments, the initial API gravity of oil in the formation is at most 10°, at most 20°, at most 25°, or at most 30°. In certain embodiments, the viscosity of oil in the formation is at least 0.05 Pa·s (50 cp). In some embodiments, the viscosity of oil in the formation is at least 0.10 Pa·s (100 cp), at least 0.15 Pa·s (150 cp), or at least at least 0.20 Pa·s (200 cp). Large amounts of natural gas may have to be utilized to provide gas lift of oil with viscosities above 0.05 Pa·s. Reducing the viscosity of oil at or near the production wellbore in the formation to a viscosity of 0.05 Pa·s (50 cp), 0.03 Pa·s (30 cp), 0.02 Pa·s (20 cp), 0.01 Pa·s (10 cp), or less (down to 0.001 Pa·s (1 cp) or lower) lowers the amount of natural gas

or other fluid needed to lift oil from the formation. In some embodiments, reduced viscosity oil is produced by other methods such as pumping.

[0851] The rate of production of oil from the formation may be increased by raising the temperature at or near a production wellbore to reduce the viscosity of the oil in the formation and adjacent to the production wellbore. In certain embodiments, the rate of production of oil from the formation is increased by 2 times, 3 times, 4 times, or greater over standard cold production with no external heating of formation during production. Certain formations may be more economically viable for enhanced oil production using the heating of the near production wellbore region. Formations that have a cold production rate approximately between 0.05 m³/(day per meter of wellbore length) and 0.20 m³/(day per meter of wellbore length) may have significant improvements in production rate using heating to reduce the viscosity in the near production wellbore region. In some formations, production wells up to 775 m, up to 1000 m, or up to 1500 m in length are used. Thus, a significant increase in production is achievable in some formations. Heating the near production wellbore region may be used in formations where the cold production rate is not between 0.05 m³/(day per meter of wellbore length) and 0.20 m³/(day per meter of wellbore length), but heating such formations may not be as economically favorable. Higher cold production rates may not be significantly increased by heating the near wellbore region, while lower production rates may not be increased to an economically useful value.

[0852] Using the temperature limited heater to reduce the viscosity of oil at or near the production well inhibits problems associated with non-temperature limited heaters and heating the oil in the formation due to hot spots. One possible problem is that non-temperature limited heaters can cause coking of oil at or near the production well if the heater overheats the oil because the heaters are at too high a temperature. Higher temperatures in the production well may also cause brine to boil in the well, which may lead to scale formation in the well. Non-temperature limited heaters that reach higher temperatures may also cause damage to other wellbore components (for example, screens used for sand control, pumps, or valves). Hot spots may be caused by portions of the formation expanding against or collapsing on the heater. In some embodiments, the heater (either the temperature limited heater or another type of non-temperature limited heater) has sections that are lower because of sagging over long heater distances. These lower sections may sit in heavy oil or bitumen that collects in lower portions of the wellbore. At these lower sections, the heater may develop hot spots due to coking of the heavy oil or bitumen. A standard non-temperature limited heater may overheat at these hot spots, thus producing a non-uniform amount of heat along the length of the heater. Using the temperature limited heater may inhibit overheating of the heater at hot spots or lower sections and provide more uniform heating along the length of the wellbore.

[0853] In certain embodiments, fluids in the relatively permeable formation containing heavy hydrocarbons are produced with little or no pyrolyzation of hydrocarbons in the formation. In certain embodiments, the relatively permeable formation containing heavy hydrocarbons is a tar sands formation. For example, the formation may be a tar sands formation such as the Athabasca tar sands formation in Alberta, Canada or a carbonate formation such as the Grosmont car-

bonate formation in Alberta, Canada. The fluids produced from the formation are mobilized fluids. Producing mobilized fluids may be more economical than producing pyrolyzed fluids from the tar sands formation. Producing mobilized fluids may also increase the total amount of hydrocarbons produced from the tar sands formation.

[0854] FIGS. 99-102 depict side view representations of embodiments for producing mobilized fluids from tar sands formations. In FIGS. 99-102, heaters 412 have substantially horizontal heating sections in hydrocarbon layer 388 (as shown, the heaters have heating sections that go into and out of the page). Hydrocarbon layer 388 may be below overburden 400. FIG. 99 depicts a side view representation of an embodiment for producing mobilized fluids from a tar sands formation with a relatively thin hydrocarbon layer. FIG. 100 depicts a side view representation of an embodiment for producing mobilized fluids from a hydrocarbon layer that is thicker than the hydrocarbon layer depicted in FIG. 99. FIG. 101 depicts a side view representation of an embodiment for producing mobilized fluids from a hydrocarbon layer that is thicker than the hydrocarbon layer depicted in FIG. 100. FIG. 102 depicts a side view representation of an embodiment for producing mobilized fluids from a tar sands formation with a hydrocarbon layer that has a shale break.

[0855] In FIG. 99, heaters 412 are placed in an alternating triangular pattern in hydrocarbon layer 388. In FIGS. 100, 101, and 102, heaters 412 are placed in an alternating triangular pattern in hydrocarbon layer 388 that repeats vertically to encompass a majority or all of the hydrocarbon layer. In FIG. 102, the alternating triangular pattern of heaters 412 in hydrocarbon layer 388 repeats uninterrupted across shale break 600. In FIGS. 99-102, heaters 412 may be equidistantly spaced from each other. In the embodiments depicted in FIGS. 99-102, the number of vertical rows of heaters 412 depends on factors such as, but not limited to, the desired spacing between the heaters, the thickness of hydrocarbon layer 388, and/or the number and location of shale breaks 600. In some embodiments, heaters 412 are arranged in other patterns. For example, heaters 412 may be arranged in patterns such as, but not limited to, hexagonal patterns, square patterns, or rectangular patterns.

[0856] In the embodiments depicted in FIGS. 99-102, heaters 412 provide heat that mobilizes hydrocarbons (reduces the viscosity of the hydrocarbons) in hydrocarbon layer 388. In certain embodiments, heaters 412 provide heat that reduces the viscosity of the hydrocarbons in hydrocarbon layer 388 below about 0.50 Pa·s (500 cp), below about 0.10 Pa·s (100 cp), or below about 0.05 Pa·s (50 cp). The spacing between heaters 412 and/or the heat output of the heaters may be designed and/or controlled to reduce the viscosity of the hydrocarbons in hydrocarbon layer 388 to desirable values. Heat provided by heaters 412 may be controlled so that little or no pyrolyzation occurs in hydrocarbon layer 388. Superposition of heat between the heaters may create one or more drainage paths (for example, paths for flow of fluids) between the heaters. In certain embodiments, production wells 206A and/or production wells 206B are located proximate heaters 412 so that heat from the heaters superimposes over the production wells. The superimposition of heat from heaters 412 over production wells 206A and/or production wells 206B creates one or more drainage paths from the heaters to the production wells. In certain embodiments, one or more of the drainage paths converge. For example, the drainage paths may converge at or near a bottommost heater and/or the

drainage paths may converge at or near production wells 206A and/or production wells 206B. Fluids mobilized in hydrocarbon layer 388 tend to flow towards the bottommost heaters 412, production wells 206A and/or production wells 206B in the hydrocarbon layer because of gravity and the heat and pressure gradients established by the heaters and/or the production wells. The drainage paths and/or the converged drainage paths allow production wells 206A and/or production wells 206B to collect mobilized fluids in hydrocarbon layer 388.

[0857] In certain embodiments, hydrocarbon layer 388 has sufficient permeability to allow mobilized fluids to drain to production wells 206A and/or production wells 206B. For example, hydrocarbon layer 388 may have a permeability of at least about 0.1 darcy, at least about 1 darcy, at least about 10 darcy, or at least about 100 darcy. In some embodiments, hydrocarbon layer 388 has a relatively large vertical permeability to horizontal permeability ratio (K_v/K_h). For example, hydrocarbon layer 388 may have a K_v/K_h ratio between about 0.01 and about 2, between about 0.1 and about 1, or between about 0.3 and about 0.7.

[0858] In certain embodiments, fluids are produced through production wells 206A located near heaters 412 in the lower portion of hydrocarbon layer 388. In some embodiments, fluids are produced through production wells 206B located below and approximately midway between heaters 412 in the lower portion of hydrocarbon layer 388. At least a portion of production wells 206A and/or production wells 206B may be oriented substantially horizontal in hydrocarbon layer 388 (as shown in FIGS. 99-102, the production wells have horizontal portions that go into and out of the page). Production wells 206A and/or 206B may be located proximate lower portion heaters 412 or the bottommost heaters.

[0859] In some embodiments, production wells 206A are positioned substantially vertically below the bottommost heaters in hydrocarbon layer 388. Production wells 206A may be located below heaters 412 at the bottom vertex of a pattern of the heaters (for example, at the bottom vertex of the triangular pattern of heaters depicted in FIGS. 99-102). Locating production wells 206A substantially vertically below the bottommost heaters may allow for efficient collection of mobilized fluids from hydrocarbon layer 388.

[0860] In certain embodiments, the bottommost heaters are located between about 2 m and about 10 m from the bottom of hydrocarbon layer 388, between about 4 m and about 8 m from the bottom of the hydrocarbon layer, or between about 5 m and about 7 m from the bottom of the hydrocarbon layer. In certain embodiments, production wells 206A and/or production wells 206B are located at a distance from the bottommost heaters 412 that allows heat from the heaters to superimpose over the production wells but at a distance from the heaters that inhibits coking at the production wells. Production wells 206A and/or production wells 206B may be located a distance from the nearest heater (for example, the bottommost heater) of at most $\frac{3}{4}$ of the spacing between heaters in the pattern of heaters (for example, the triangular pattern of heaters depicted in FIGS. 99-102). In some embodiments, production wells 206A and/or production wells 206B are located a distance from the nearest heater of at most $\frac{2}{3}$, at most $\frac{1}{2}$, or at most $\frac{1}{3}$ of the spacing between heaters in the pattern of heaters. In certain embodiments, production wells 206A and/or production wells 206B are located between about 2 m and about 10 m from the bottommost heaters, between about 4 m

and about 8 m from the bottommost heaters, or between about 5 m and about 7 m from the bottommost heaters. Production wells 206A and/or production wells 206B may be located between about 0.5 m and about 8 m from the bottom of hydrocarbon layer 388, between about 1 m and about 5 m from the bottom of the hydrocarbon layer, or between about 2 m and about 4 m from the bottom of the hydrocarbon layer.

[0861] In some embodiments, at least some production wells 206A are located substantially vertically below heaters 412 near shale break 600, as depicted in FIG. 102. Production wells 206A may be located between heaters 412 and shale break 600 to produce fluids that flow and collect above the shale break. Shale break 600 may be an impermeable barrier in hydrocarbon layer 388. In some embodiments, shale break 600 has a thickness between about 1 m and about 6 m, between about 2 m and about 5 m, or between about 3 m and about 4 m. Production wells 206A between heaters 412 and shale break 600 may produce fluids from the upper portion of hydrocarbon layer 388 (above the shale break) and production wells 206A below the bottommost heaters in the hydrocarbon layer may produce fluids from the lower portion of the hydrocarbon layer (below the shale break), as depicted in FIG. 102. In some embodiments, two or more shale breaks may exist in a hydrocarbon layer. In such an embodiment, production wells are placed at or near each of the shale breaks to produce fluids flowing and collecting above the shale breaks.

[0862] In some embodiments, shale break 600 breaks down (is desiccated or decomposes) as the shale break is heated by heaters 412 on either side of the shale break. As shale break 600 breaks down, the permeability of the shale break increases and fluids flow through the shale break. Once fluids are able to flow through shale break 600, production wells above the shale break may not be needed for production as fluids can flow to production wells at or near the bottom of hydrocarbon layer 388 and be produced there.

[0863] In certain embodiments, the bottommost heaters above shale break 600 are located between about 2 m and about 10 m from the shale break, between about 4 m and about 8 m from the bottom of the shale break, or between about 5 m and about 7 m from the shale break. Production wells 206A may be located between about 2 m and about 10 m from the bottommost heaters above shale break 600, between about 4 m and about 8 m from the bottommost heaters above the shale break, or between about 5 m and about 7 m from the bottommost heaters above the shale break. Production wells 206A may be located between about 0.5 m and about 8 m from shale break 600, between about 1 m and about 5 m from the shale break, or between about 2 m and about 4 m from the shale break.

[0864] In some embodiments, heat is provided in production wells 206A and/or production wells 206B, depicted in FIGS. 99-102. Providing heat in production wells 206A and/or production wells 206B may maintain and/or enhance the mobility of the fluids in the production wells. Heat provided in production wells 206A and/or production wells 206B may superimpose with heat from heaters 412 to create the flow path from the heaters to the production wells. In some embodiments, production wells 206A and/or production wells 206B include a pump to move fluids to the surface of the formation. In some embodiments, the viscosity of fluids (oil) in production wells 206A and/or production wells 206B is

lowered using heaters and/or diluent injection (for example, using a conduit in the production wells for injecting the diluent).

[0865] In certain embodiments, in situ heat treatment of the relatively permeable formation containing hydrocarbons (for example, the tar sands formation) includes heating the formation to visbreaking temperatures. For example, the formation may be heated to temperatures between about 100° C. and 260° C., between about 150° C. and about 250° C., between about 200° C. and about 240° C., between about 205° C. and 230° C., between about 210° C. and 225° C. In one embodiment, the formation is heated to a temperature of about 220° C. In one embodiment, the formation is heated to a temperature of about 230° C. At visbreaking temperatures, fluids in the formation have a reduced viscosity (versus their initial viscosity at initial formation temperature) that allows fluids to flow in the formation. The reduced viscosity at visbreaking temperatures may be a permanent reduction in viscosity as the hydrocarbons go through a step change in viscosity at visbreaking temperatures (versus heating to mobilization temperatures, which may only temporarily reduce the viscosity). The visbroken fluids may have API gravities that are relatively low (for example, at most about 10°, about 12°, about 15°, or about 19° API gravity), but the API gravities are higher than the API gravity of non-visbroken fluid from the formation. The non-visbroken fluid from the formation may have an API gravity of 7° or less.

[0866] In some embodiments, heaters in the formation are operated at full power output to heat the formation to visbreaking temperatures or higher temperatures. Operating at full power may rapidly increase the pressure in the formation. In certain embodiments, fluids are produced from the formation to maintain a pressure in the formation below a selected pressure as the temperature of the formation increases. In some embodiments, the selected pressure is a fracture pressure of the formation. In certain embodiments, the selected pressure is between about 1000 kPa and about 15000 kPa, between about 2000 kPa and about 10000 kPa, or between about 2500 kPa and about 5000 kPa. In one embodiment, the selected pressure is about 10000 kPa. Maintaining the pressure as close to the fracture pressure as possible may minimize the number of production wells needed for producing fluids from the formation.

[0867] In certain embodiments, treating the formation includes maintaining the temperature at or near visbreaking temperatures (as described above) during the entire production phase while maintaining the pressure below the fracture pressure. The heat provided to the formation may be reduced or eliminated to maintain the temperature at or near visbreaking temperatures. Heating to visbreaking temperatures but maintaining the temperature below pyrolysis temperatures or near pyrolysis temperatures (for example, below about 230° C.) inhibits coke formation and/or higher level reactions. Heating to visbreaking temperatures at higher pressures (for example, pressures near but below the fracture pressure) keeps produced gases in the liquid oil (hydrocarbons) in the formation and increases hydrogen reduction in the formation with higher hydrogen partial pressures. Heating the formation to only visbreaking temperatures also uses less energy input than heating the formation to pyrolysis temperatures.

[0868] Fluids produced from the formation may include visbroken fluids, mobilized fluids, and/or pyrolyzed fluids. In some embodiments, a produced mixture that includes these fluids is produced from the formation. The produced mixture

may have assessable properties (for example, measurable properties). The produced mixture properties are determined by operating conditions in the formation being treated (for example, temperature and/or pressure in the formation). In certain embodiments, the operating conditions may be selected, varied, and/or maintained to produce desirable properties in hydrocarbons in the produced mixture. For example, the produced mixture may include hydrocarbons that have properties that allow the mixture to be easily transported (for example, sent through a pipeline without adding diluent or blending the mixture and/or resulting hydrocarbons with another fluid).

[0869] In some embodiments, after the formation reaches visbreaking temperatures, the pressure in the formation is reduced. In certain embodiments, the pressure in the formation is reduced at temperatures above visbreaking temperatures. Reducing the pressure at higher temperatures allows more of the hydrocarbons in the formation to be converted to higher quality hydrocarbons by visbreaking and/or pyrolysis. Allowing the formation to reach higher temperatures before pressure reduction, however, may increase the amount of carbon dioxide produced and/or the amount of coking in the formation. For example, in some formations, coking of bitumen (at pressures above 700 kPa) begins at about 280° C. and reaches a maximum rate at about 340° C. At pressures below about 700 kPa, the coking rate in the formation is minimal. Allowing the formation to reach higher temperatures before pressure reduction may decrease the amount of hydrocarbons produced from the formation.

[0870] In certain embodiments, the temperature in the formation (for example, an average temperature of the formation) when the pressure in the formation is reduced is selected to balance one or more factors. The factors considered may include: the quality of hydrocarbons produced, the amount of hydrocarbons produced, the amount of carbon dioxide produced, the amount of hydrogen sulfide produced, the degree of coking in the formation, and/or the amount of water produced. Experimental assessments using formation samples and/or simulated assessments based on the formation properties may be used to assess results of treating the formation using the in situ heat treatment process. These results may be used to determine a selected temperature, or temperature range, for when the pressure in the formation is to be reduced. The selected temperature, or temperature range, may also be affected by factors such as, but not limited to, hydrocarbon or oil market conditions and other economic factors. In certain embodiments, the selected temperature is in a range between about 275° C. and about 305° C., between about 280° C. and about 300° C., or between about 285° C. and about 295° C.

[0871] In certain embodiments, an average temperature in the formation is assessed from an analysis of fluids produced from the formation. For example, the average temperature of the formation may be assessed from an analysis of the fluids that have been produced to maintain the pressure in the formation below the fracture pressure of the formation.

[0872] In some embodiments, values of the hydrocarbon isomer shift in fluids (for example, gases) produced from the formation is used to indicate the average temperature in the formation. Experimental analysis and/or simulation may be used to assess one or more hydrocarbon isomer shifts and relate the values of the hydrocarbon isomer shifts to the average temperature in the formation. The assessed relation between the hydrocarbon isomer shifts and the average temperature may then be used in the field to assess the average

temperature in the formation by monitoring one or more of the hydrocarbon isomer shifts in fluids produced from the formation. In some embodiments, the pressure in the formation is reduced when the monitored hydrocarbon isomer shift reaches a selected value. The selected value of the hydrocarbon isomer shift may be chosen based on the selected temperature, or temperature range, in the formation for reducing the pressure in the formation and the assessed relation between the hydrocarbon isomer shift and the average temperature. Examples of hydrocarbon isomer shifts that may be assessed include, but are not limited to, n-butane- $\delta^{13}\text{C}_4$ percentage versus propane- $\delta^{13}\text{C}_3$ percentage, n-pentane- $\delta^{13}\text{C}_5$ percentage versus propane- $\delta^{13}\text{C}_3$ percentage, n-pentane- $\delta^{13}\text{C}_5$ percentage versus n-butane- $\delta^{13}\text{C}_4$ percentage, and i-pentane- $\delta^{13}\text{C}_5$ percentage versus i-butane- $\delta^{13}\text{C}_4$ percentage. In some embodiments, the hydrocarbon isomer shift in produced fluids is used to indicate the amount of conversion (for example, amount of pyrolysis) that has taken place in the formation.

[0873] In some embodiments, weight percentages of saturates in fluids produced from the formation is used to indicate the average temperature in the formation. Experimental analysis and/or simulation may be used to assess the weight percentage of saturates as a function of the average temperature in the formation. For example, SARA (Saturates, Aromatics, Resins, and Asphaltenes) analysis (sometimes referred to as Asphaltene/Wax/Hydrate Deposition analysis) may be used to assess the weight percentage of saturates in a sample of fluids from the formation. In some formations, the weight percentage of saturates has a linear relationship to the average temperature in the formation. The relation between the weight percentage of saturates and the average temperature may then be used in the field to assess the average temperature in the formation by monitoring the weight percentage of saturates in fluids produced from the formation. In some embodiments, the pressure in the formation is reduced when the monitored weight percentage of saturates reaches a selected value. The selected value of the weight percentage of saturates may be chosen based on the selected temperature, or temperature range, in the formation for reducing the pressure in the formation and the relation between the weight percentage of saturates and the average temperature. In some embodiments, the selected value of weight percentage of saturates is between about 20% and about 40%, between about 25% and about 35%, or between about 28% and about 32%. For example, the selected value may be about 30% by weight saturates.

[0874] In some embodiments, weight percentages of n-C₇ in fluids produced from the formation is used to indicate the average temperature in the formation. Experimental analysis and/or simulation may be used to assess the weight percentages of n-C₇ as a function of the average temperature in the formation. In some formations, the weight percentages of n-C₇ has a linear relationship to the average temperature in the formation. The relation between the weight percentages of n-C₇ and the average temperature may then be used in the field to assess the average temperature in the formation by monitoring the weight percentages of n-C₇ in fluids produced from the formation. In some embodiments, the pressure in the formation is reduced when the monitored weight percentage of n-C₇ reaches a selected value. The selected value of the weight percentage of n-C₇ may be chosen based on the selected temperature, or temperature range, in the formation for reducing the pressure in the formation and the relation

between the weight percentage of n-C₇ and the average temperature. In some embodiments, the selected value of weight percentage of n-C₇ is between about 50% and about 70%, between about 55% and about 65%, or between about 58% and about 62%. For example, the selected value may be about 60% by weight n-C₇.

[0875] The pressure in the formation may be reduced by producing fluids (for example, visbroken fluids and/or mobilized fluids) from the formation. In some embodiments, the pressure is reduced below a pressure at which fluids coke in the formation to inhibit coking at pyrolysis temperatures. For example, the pressure is reduced to a pressure below about 1000 kPa, below about 800 kPa, or below about 700 kPa (for example, about 690 kPa). In certain embodiments, the selected pressure is at least about 100 kPa, at least about 200 kPa, or at least about 300 kPa. The pressure may be reduced to inhibit coking of asphaltenes or other high molecular weight hydrocarbons in the formation. In some embodiments, the pressure may be maintained below a pressure at which water passes through a liquid phase at downhole (formation) temperatures to inhibit liquid water and dolomite reactions. After reducing the pressure in the formation, the temperature may be increased to pyrolysis temperatures to begin pyrolyzation and/or upgrading of fluids in the formation. The pyrolyzed and/or upgraded fluids may be produced from the formation.

[0876] In certain embodiments, the amount of fluids produced at temperatures below visbreaking temperatures, the amount of fluids produced at visbreaking temperatures, the amount of fluids produced before reducing the pressure in the formation, and/or the amount of upgraded or pyrolyzed fluids produced may be varied to control the quality and amount of fluids produced from the formation and the total recovery of hydrocarbons from the formation. For example, producing more fluid during the early stages of treatment (for example, producing fluids before reducing the pressure in the formation) may increase the total recovery of hydrocarbons from the formation while reducing the overall quality (lowering the overall API gravity) of fluid produced from the formation. The overall quality is reduced because more heavy hydrocarbons are produced by producing more fluids at the lower temperatures. Producing less fluids at the lower temperatures may increase the overall quality of the fluids produced from the formation but may lower the total recovery of hydrocarbons from the formation. The total recovery may be lower because more coking occurs in the formation when less fluids are produced at lower temperatures.

[0877] In certain embodiments, the formation is heated using isolated cells of heaters (cells or sections of the formation that are not interconnected for fluid flow). The isolated cells may be created by using larger heater spacings in the formation. For example, large heater spacings may be used in the embodiments depicted in FIGS. 99-102. These isolated cells may be produced during early stages of heating (for example, at temperatures below visbreaking temperatures). Because the cells are isolated from other cells in the formation, the pressures in the isolated cells are high and more liquids are producible from the isolated cells. Thus, more liquids may be produced from the formation and a higher total recovery of hydrocarbons may be reached. During later stages of heating, the heat gradient may interconnect the isolated cells and pressures in the formation will drop.

[0878] In certain embodiments, the heat gradient in the formation is modified so that a gas cap is created at or near an

upper portion of the hydrocarbon layer. For example, the heat gradient made by heaters 412 depicted in the embodiments depicted in FIGS. 99-102 may be modified to create the gas cap at or near overburden 400 of hydrocarbon layer 388. The gas cap may push or drive liquids to the bottom of the hydrocarbon layer so that more liquids may be produced from the formation. In situ generation of the gas cap may be more efficient than introducing pressurized fluid into the formation. The in situ generated gas cap applies force evenly through the formation with little or no channeling or fingering that may reduce the effectiveness of introduced pressurized fluid.

[0879] In certain embodiments, the number and/or location of production wells in the formation is varied based on the viscosity of fluid in the formation. The viscosities in the zones may be assessed before placing the production wells in the formation, before heating the formation, and/or after heating the formation. In some embodiments, more production wells are located in zones in the formation that have lower viscosities. For example, in certain formations, upper portions, or zones, of the formation may have lower viscosities. In some embodiments, more production wells are located in the upper zones. Producing through production wells in the less viscous zones of the formation may result in production of higher quality (more upgraded) oil from the formation.

[0880] In some embodiments, more production wells are located in zones in the formation that have higher viscosities. Pressure propagation may be slower in the zones with higher viscosities. The slower pressure propagation may make it more difficult to control pressure in the zones with higher viscosities. Thus, more production wells may be located in the zones with higher viscosities to provide better pressure control in these zones.

[0881] In some embodiments, zones in the formation with different assessed viscosities are heated at different rates. In certain embodiments, zones in the formation with higher viscosities are heated at higher heating rates than zones with lower viscosities. Heating the zones with higher viscosities at the higher heating rates mobilizes and/or upgrades these zones at a faster rate so that these zones may "catch up" in viscosity and/or quality to the slower heated zones.

[0882] In some embodiments, the heater spacing is varied to provide different heating rates to zones in the formation with different assessed viscosities. For example, denser heater spacings (less spaces between heaters) may be used in zones with higher viscosities to heat these zones at higher heating rates. In some embodiments, a production well (for example, a substantially vertical production well) is located in the zones with denser heater spacings and higher viscosities. The production well may be used to remove fluids from the formation and relieve pressure from the higher viscosity zones. In some embodiments, one or more substantially vertical openings, or production wells, are located in the higher viscosity zones to allow fluids to drain in the higher viscosity zones. The draining fluids may be produced from the formation through production wells located near the bottom of the higher viscosity zones.

[0883] In certain embodiments, production wells are located in more than one zone in the formation. The zones may have different initial permeabilities. In certain embodiments, a first zone has an initial permeability of at least about 1 darcy and a second zone has an initial permeability of at most about 0.1 darcy. In some embodiments, the first zone has an initial permeability of between about 1 darcy and about 10 darcy. In some embodiments, the second zone has an initial

permeability between about 0.01 darcy and 0.1 darcy. The zones may be separated by a substantially impermeable barrier (with an initial permeability of about 10 μ darcy or less). Having the production well located in both zones allows for fluid communication (permeability) between the zones and/or pressure equalization between the zones.

[0884] In some embodiments, openings (for example, substantially vertical openings) are formed between zones with different initial permeabilities that are separated by a substantially impermeable barrier. Bridging the zones with the openings allows for fluid communication (permeability) between the zones and/or pressure equalization between the zones. In some embodiments, openings in the formation (such as pressure relief openings and/or production wells) allow gases or low viscosity fluids to rise in the openings. As the gases or low viscosity fluids rise, the fluids may condense or increase viscosity in the openings so that the fluids drain back down the openings to be further upgraded in the formation. Thus, the openings may act as heat pipes by transferring heat from the lower portions to the upper portions where the fluids condense. The wellbores may be packed and sealed near or at the overburden to inhibit transport of formation fluid to the surface.

[0885] In some embodiments, production of fluids is continued after reducing and/or turning off heating of the formation. The formation may be heated for a selected time. The formation may be heated until it reaches a selected average temperature. Production from the formation may continue after the selected time. Continuing production may produce more fluid from the formation as fluids drain towards the bottom of the formation and/or as fluids are upgraded by passing by hot spots in the formation. In some embodiments, a horizontal production well is located at or near the bottom of the formation (or a zone of the formation) to produce fluids after heating is turned down and/or off.

[0886] In certain embodiments, initially produced fluids (for example, fluids produced below visbreaking temperatures), fluids produced at visbreaking temperatures, and/or other viscous fluids produced from the formation are blended with diluent to produce fluids with lower viscosities. In some embodiments, the diluent includes upgraded or pyrolyzed fluids produced from the formation. In some embodiments, the diluent includes upgraded or pyrolyzed fluids produced from another portion of the formation or another formation. In certain embodiments, the amount of fluids produced at temperatures below visbreaking temperatures and/or fluids produced at visbreaking temperatures that are blended with upgraded fluids from the formation is adjusted to create a fluid suitable for transportation and/or use in a refinery. The amount of blending may be adjusted so that the fluid has chemical and physical stability. Maintaining the chemical and physical stability of the fluid may allow the fluid to be transported, reduce pre-treatment processes at a refinery and/or reduce or eliminate the need for adjusting the refinery process to compensate for the fluid.

[0887] In certain embodiments, formation conditions (for example, pressure and temperature) and/or fluid production are controlled to produce fluids with selected properties. For example, formation conditions and/or fluid production may be controlled to produce fluids with a selected API gravity and/or a selected viscosity. The selected API gravity and/or selected viscosity may be produced by combining fluids produced at different formation conditions (for example, combining fluids produced at different temperatures during the

treatment as described above). As an example, formation conditions and/or fluid production may be controlled to produce fluids with an API gravity of about 19° and a viscosity of about 0.35 Pa·s (350 cp) at 5° C.

[0888] In certain embodiments, a drive process (for example, a steam injection process such as cyclic steam injection, a steam assisted gravity drainage process (SAGD), a solvent injection process, a vapor solvent and SAGD process, or a carbon dioxide injection process) is used to treat the tar sands formation in addition to the in situ heat treatment process. In some embodiments, heaters are used to create high permeability zones (or injection zones) in the formation for the drive process. Heaters may be used to create a mobilization geometry or production network in the formation to allow fluids to flow through the formation during the drive process. For example, heaters may be used to create drainage paths between the heaters and production wells for the drive process. In some embodiments, the heaters are used to provide heat during the drive process. The amount of heat provided by the heaters may be small compared to the heat input from the drive process (for example, the heat input from steam injection).

[0889] The concentration of components in the formation and/or produced fluids may change during an in situ heat treatment process. As the concentration of the components in the formation and/or produced fluids and/or hydrocarbons separated from the produced fluid changes due to formation of the components, solubility of the components in the produced fluids and/or separated hydrocarbons tends to change. Hydrocarbons separated from the produced fluid may be hydrocarbons that have been treated to remove salty water and/or gases from the produced fluid. For example, the produced fluids and/or separated hydrocarbons may contain components that are soluble in the condensable hydrocarbon portion of the produced fluids at the beginning of processing. As properties of the hydrocarbons in the produced fluids change (for example, TAN, asphaltenes, P-value, olefin content, mobilized fluids content, visbroken fluids content, pyrolyzed fluids content, or combinations thereof), the components may tend to become less soluble in the produced fluids and/or in the hydrocarbon stream separated from the produced fluids. In some instances, components in the produced fluids and/or components in the separated hydrocarbons may form two phases and/or become insoluble. Formation of two phases, through flocculation of asphaltenes, change in concentration of components in the produced fluids, change in concentration of components in separated hydrocarbons, and/or precipitation of components may result in hydrocarbons that do not meet pipeline, transportation, and/or refining specifications. Additionally, the efficiency of the process may be reduced. For example, further treatment of the produced fluids and/or separated hydrocarbons may be necessary to produce products with desired properties.

[0890] During processing, the P-value of the separated hydrocarbons may be monitored and the stability of the produced fluids and/or separated hydrocarbons may be assessed. Typically, a P-value that is at most 1.0 indicates that flocculation of asphaltenes from the separated hydrocarbons generally occurs. If the P-value is initially at least 1.0, and such P-value increases or is relatively stable during heating, then this indicates that the separated hydrocarbons are relatively stable. Stability of separated hydrocarbons, as assessed by P-value, may be controlled by controlling operating condi-

tions in the formation such as temperature, pressure, hydrogen uptake, hydrocarbon feed flow, or combinations thereof.

[0891] In some embodiments, change in API gravity may not occur unless the formation temperature is at least 100° C. For some formations, temperatures of at least 220° C. may be required to produce hydrocarbons that meet desired specifications. At increased temperatures coke formation may occur, even at elevated pressures. As the properties of the formation are changed, the P-value of the separated hydrocarbons may decrease below 1.0 and/or sediment may form, causing the separated hydrocarbons to become unstable.

[0892] In some embodiments, olefins may form during heating of formation fluids to produce fluids having a reduced viscosity. Separated hydrocarbons that include olefins may be unacceptable for processing facilities. Olefins in the separated hydrocarbons may cause fouling and/or clogging of processing equipment. For example, separated hydrocarbons that contains olefins may cause coking of distillation units in a refinery, which results in frequent down time to remove the coked material from the distillation units.

[0893] During processing, the olefin content of separated hydrocarbons may be monitored and quality of the separated hydrocarbons assessed. Typically, separated hydrocarbons having a bromine number of 3% and/or a CAPP olefin number of 3% as 1-decene equivalent indicates that olefin production is occurring. If the olefin value decreases or is relatively stable during producing, then this indicates that a minimal or substantially low amount of olefins are being produced. Olefin content, as assessed by bromine value and/or CAPP olefin number, may be controlled by controlling operating conditions in the formation such as temperature, pressure, hydrogen uptake, hydrocarbon feed flow, or combinations thereof.

[0894] In some embodiments, the P-value and/or olefin content may be controlled by controlling operating conditions. For example, if the temperature increases above 225° C. and the P-value drops below 1.0, the separated hydrocarbons may become unstable. Alternatively, the bromine number and/or CAPP olefin number may increase to above 3%. If the temperature is maintained below 225° C., minimal changes to the hydrocarbon properties may occur. In certain embodiments, operating conditions are selected, varied, and/or maintained to produce separated hydrocarbons having a P-value of at least about 1, at least about 1.1, at least about 1.2, or at least about 1.3. In certain embodiments, operating conditions are selected, varied, and/or maintained to produce separated hydrocarbons having a bromine number of at most about 3%, at most about 2.5%, at most about 2%, or at most about 1.5%. Heating of the formation at controlled operating conditions includes operating at temperatures between about 100° C. and about 260° C., between about 150° C. and about 250° C., between about 200° C. and about 240° C., between about 210° C. and about 230° C., or between about 215° C. and about 225° C. Pressures may be between about 1000 kPa and about 15000 kPa, between about 2000 kPa and about 10000 kPa, or between about 2500 kPa and about 5000 kPa or at or near a fracture pressure of the formation. In certain embodiments, the selected pressure of about 10000 kPa produces separated hydrocarbons having properties acceptable for transportation and/or refineries (for example, viscosity, P-value, API gravity, and/or olefin content within acceptable ranges).

[0895] Examples of produced mixture properties that may be measured and used to assess the separated hydrocarbon portion of the produced mixture include, but are not limited

to, liquid hydrocarbon properties such as API gravity, viscosity, asphaltene stability (P-value), and olefin content (bromine number and/or CAPP number). In certain embodiments, operating conditions in the formation are selected, varied, and/or maintained to produce an API gravity of at least about 15°, at least about 17°, at least about 19°, or at least about 20° in the produced mixture. In certain embodiments, operating conditions in the formation are selected, varied, and/or maintained to produce a viscosity (measured at 1 atm and 5° C.) of at most about 400 cp, at most about 350 cp, at most about 250 cp, or at most about 100 cp in the produced mixture. As an example, the initial viscosity of fluid in the formation is above about 1000 cp or, in some cases, above about 1 million cp. In certain embodiments, operating conditions are selected, varied, and/or maintained to produce an asphaltene stability (P-value) of at least about 1, at least about 1.1, at least about 1.2, or at least about 1.3 in the produced mixture. In certain embodiments, operating conditions are selected, varied, and/or maintained to produce a bromine number of at most about 3%, at most about 2.5%, at most about 2%, or at most about 1.5% in the produced mixture.

[0896] In certain embodiments, the mixture is produced from one or more production wells located at or near the bottom of the hydrocarbon layer being treated. In other embodiments, the mixture is produced from other locations in the hydrocarbon layer being treated (for example, from an upper portion of the layer or a middle portion of the layer).

[0897] In one embodiment, the formation is heated to 220° C. or 230° C. while maintaining the pressure in the formation below 10000 kPa. The separated hydrocarbon portion of the mixture produced from the formation may have several desirable properties such as, but not limited to, an API gravity of at least 19°, a viscosity of at most 350 cp, a P-value of at least 1.1, and a bromine number of at most 2%. Such separated hydrocarbons may be transportable through a pipeline without adding diluent or blending the mixture with another fluid. The mixture may be produced from one or more production wells located at or near the bottom of the hydrocarbon layer being treated.

[0898] The in situ heat treatment process may provide less heat to the formation (for example, use a wider heater spacing) if the in situ heat treatment process is followed by a drive process. The drive process may involve introducing a hot fluid into the formation to increase the amount of heat provided to the formation. In some embodiments, the heaters of the in situ heat treatment process may be used to pretreat the formation to establish injectivity for the subsequent drive process. In some embodiments, the in situ heat treatment process creates or produces the drive fluid in situ. The in situ produced drive fluid may move through the formation and move mobilized hydrocarbons from one portion of the formation to another portion of the formation.

[0899] FIG. 103 depicts a top view representation of an embodiment for preheating using heaters before using the drive process (for example, a steam drive process). Injection wells 602 and production wells 206 are substantially vertical wells. Heaters 412 are long substantially horizontal heaters positioned so that the heaters pass in the vicinity of injection wells 602. Heaters 412 intersect the vertical well patterns slightly displaced from the vertical wells.

[0900] The vertical location of heaters 412 with respect to injection wells 602 and production wells 206 depends on, for example, the vertical permeability of the formation. In formations with at least some vertical permeability, injected

steam will rise to the top of the permeable layer in the formation. In such formations, heaters **412** may be located near the bottom of the hydrocarbon layer **388**, as shown in FIG. **104**. In formations with very low vertical permeabilities, more than one horizontal heater may be used with the heaters stacked substantially vertically or with heaters at varying depths in the hydrocarbon layer (for example, heater patterns as shown in FIGS. **99-102**). The vertical spacing between the horizontal heaters in such formations may correspond to the distance between the heaters and the injection wells. Heaters **412** are located in the vicinity of injection wells **602** and/or production wells **206** so that sufficient energy is delivered by the heaters to provide flow rates for the drive process that are economically viable. The spacing between heaters **412** and injection wells **602** or production wells **206** may be varied to provide an economically viable drive process. The amount of preheating may also be varied to provide an economically viable process.

[0901] In some embodiments, the steam injection (or drive) process (for example, SAGD, cyclic steam soak, or another steam recovery process) is used to treat the formation and produce hydrocarbons from the formation. The steam injection process may recover a low amount of oil in place from the formation (for example, less than 20% recovery of oil in place from the formation). The in situ heat treatment process may be used following the steam injection process to increase the recovery of oil in place from the formation. In certain embodiments, the steam injection process is used until the steam injection process is no longer efficient at removing hydrocarbons from the formation (for example, until the steam injection process is no longer economically feasible). The in situ heat treatment process is used to produce hydrocarbons remaining in the formation after the steam injection process. Using the in situ heat treatment process after the steam injection process may allow recovery of at least about 25%, at least about 50%, at least about 55%, or at least about 60% of oil in place in the formation.

[0902] In some embodiments, the formation has been at least somewhat heated by the steam injection process before treating the formation using the in situ heat treatment process. For example, the steam injection process may heat the formation to an average temperature between about 200° C. and about 250° C., between about 175° C. and about 265° C., or between about 150° C. and about 270° C. In certain embodiments, the heaters are placed in the formation after the steam injection process is at least 50% completed, at least 75% completed, or near 100% completed. The heaters provide heat for treating the formation using the in situ heat treatment process. In some embodiments, the heaters are already in place in the formation during the steam injection process. In such embodiments, the heaters may be energized after the steam injection process is completed or when production of hydrocarbons using the steam injection process is reduced below a desired level. In some embodiments, steam injection wells from the steam injection process are converted to heater wells for the in situ heat treatment process.

[0903] Treating the formation with the in situ heat treatment process after the steam injection process may be more efficient than only treating the formation with the in situ heat treatment process. The steam injection process may provide some energy (heat) to the formation with the steam. Any energy added to the formation during the steam injection process reduces the amount of energy needed to be supplied by heaters for the in situ heat treatment process. Reducing the

amount of energy supplied by heaters reduces costs for treating the formation using the in situ heat treatment process.

[0904] In certain embodiments, treating the formation using the steam injection process does not treat the formation uniformly. For example, steam injection may not be uniform throughout the formation. Variations in the properties of the formation (for example, fluid injectivities, permeabilities, and/or porosities) may result in non-uniform injection of the steam through the formation. Because of the non-uniform injection of the steam, the steam may remove hydrocarbons from different portions of the formation at different rates or with different results. For example, some portions of the formation may have little or no steam injectivity, which inhibits the hydrocarbon production from these portions. After the steam injection process is completed, the formation may have portions that have lower amounts of hydrocarbons produced (more hydrocarbons remaining) than other parts of the formation.

[0905] FIG. **105** depicts a side view representation of an embodiment of a tar sands formation subsequent to a steam injection process. Injection well **602** is used to inject steam into hydrocarbon layer **388** below overburden **400**. Portion **604** may have little or no steam injectivity and have small amounts of hydrocarbons or no hydrocarbons at all removed by the steam injection process. Portions **606** may include portions that have steam injectivity and measurable amounts of hydrocarbons are removed by the steam injection process. Thus, portion **604** may have a greater amount of hydrocarbons remaining than portions **606** following treatment with the steam injection process. In some embodiments, hydrocarbon layer **388** includes two or more portions **604** with more hydrocarbons remaining than portions **606**.

[0906] In some embodiments, the portions with more hydrocarbons remaining (such as portion **604**, depicted in FIG. **105**) are large portions of the formation. In some embodiments, the amount of hydrocarbons remaining in these portions is significantly higher than other portions of the formation (such as portions **606**). For example, portions **604** may have a recovery of at most about 10% of the oil in place and portions **606** may have a recovery of at least about 30% of the oil in place. In some embodiments, portions **604** have a recovery of between about 0% and about 10% of the oil in place, between about 0% and about 15% of the oil in place, or between about 0% and about 20% of the oil in place. The portions **606** may have a recovery of between about 20% and about 25% of the oil in place, between about 20% and about 40% of the oil in place, or between about 20% and about 50% of the oil in place. Coring, logging techniques, and/or seismic imaging may be used to assess hydrocarbons remaining in the formation and assess the location of one or more of the first and/or second portions.

[0907] In certain embodiments, during the in situ heat treatment process, more heat is provided to the first portions of the formation that have more hydrocarbons remaining than the second portions with less hydrocarbons remaining. In some embodiments, heaters are located in the first portions but not in the second portions. In some embodiments, heaters are located in both the first portions and the second portions but the heaters in the first portions are designed or operated to provide more heat than the heaters in the second portions. In some embodiments, heaters pass through both first portions and second portions and the heaters are designed or operated to provide more heat in the first portions than the second portions.

[0908] In some embodiments, steam injection is continued during the in situ heat treatment process. For example, steam injection may be continued while liquids are being produced from the formation. The steam injection may increase the production of liquids from the formation. In certain embodiments, steam injection may be reduced or stopped when gas production from the formation begins.

[0909] In some embodiments, the formation is treated using the in situ heat treatment process a significant time after the formation has been treated using the steam injection process. For example, the in situ heat treatment process is used 1 year, 2 years, 3 years, or longer (for example, 10 years to 20 years) after a formation has been treated using the steam injection process. During this dormant period, heat from the steam injection process may diffuse to cooler parts of the formation and result in a more uniform preheating of the formation prior to in situ heat treatment. The in situ heat treatment process may be used on formations that have been left dormant after the steam injection process treatment because further hydrocarbon production using the steam injection process is not possible and/or not economically feasible. In some embodiments, the formation remains at least somewhat heated from the steam injection process even after the significant time.

[0910] In certain embodiments, a fluid is injected into the formation (for example, a drive fluid or an oxidizing fluid) to move hydrocarbons through the formation from a first section to a second section. In some embodiments, the hydrocarbons are moved from the first section to the second section through a third section. FIG. 106 depicts a side view representation of an embodiment using at least three treatment sections in a tar sands formation. Hydrocarbon layer 388 may be divided into three or more treatment sections. In certain embodiments, hydrocarbon layer 388 includes three different types of treatment sections: section 608A, section 608B, and section 608C. Section 608C and sections 608A are separated by sections 608B. Section 608C, sections 608A, and sections 608B may be horizontally displaced from each other in the formation. In some embodiments, one side of section 608C is adjacent to an edge of the treatment area of the formation or an untreated section of the formation is left on one side of section 608C before the same or a different pattern is formed on the opposite side of the untreated section.

[0911] In certain embodiments, sections 608A and 608C are heated at or near the same time to similar temperatures (for example, pyrolysis temperatures). Sections 608A and 608C may be heated to mobilize and/or pyrolyze hydrocarbons in the sections. The mobilized and/or pyrolyzed hydrocarbons may be produced (for example, through one or more production wells) from section 608A and/or section 608C. Section 608B may be heated to lower temperatures (for example, mobilization temperatures). Little or no production of hydrocarbons to the surface may take place through section 608B. For example, sections 608A and 608C may be heated to average temperatures of about 300° C. while section 608B is heated to an average temperature of about 100° C. and no production wells are operated in section 608B.

[0912] In certain embodiments, heating and producing hydrocarbons from section 608C creates fluid injectivity in the section. After fluid injectivity has been created in section 608C, a fluid such as a drive fluid (for example, steam, water, or hydrocarbons) and/or an oxidizing fluid (for example, air, oxygen, enriched air, or other oxidants) may be injected into the section. The fluid may be injected through heaters 412, a

production well, and/or an injection well located in section 608C. In some embodiments, heaters 412 continue to provide heat while the fluid is being injected. In other embodiments, heaters 412 may be turned down or off before or during fluid injection.

[0913] In some embodiments, providing oxidizing fluid such as air to section 608C causes oxidation of hydrocarbons in the section. For example, coked hydrocarbons and/or heated hydrocarbons in section 608C may oxidize if the temperature of the hydrocarbons is above an oxidation ignition temperature. In some embodiments, treatment of section 608C with the heaters creates coked hydrocarbons with substantially uniform porosity and/or substantially uniform injectivity so that heating of the section is controllable when oxidizing fluid is introduced to the section. The oxidation of hydrocarbons in section 608C will maintain the average temperature of the section or increase the average temperature of the section to higher temperatures (for example, about 400° C. or above).

[0914] In some embodiments, injection of the oxidizing fluid is used to heat section 608C and a second fluid is introduced into the formation after or with the oxidizing fluid to create drive fluids in the section. During injection of oxidant, excess oxidant and/or oxidation products may be removed from section 608C through one or more production wells. After the formation is raised to a desired temperature, a second fluid may be introduced into section 608C to react with coke and/or hydrocarbons and generate drive fluid (for example, synthesis gas). In some embodiments, the second fluid includes water and/or steam. Reactions of the second fluid with carbon in the formation may be endothermic reactions that cool the formation. In some embodiments, oxidizing fluid is added with the second fluid so that some heating of section 608C occurs simultaneous with the endothermic reactions. In some embodiments, section 608C may be treated in alternating steps of adding oxidant to heat the formation, and then adding second fluid to generate drive fluids.

[0915] The generated drive fluids in section 608C may include steam, carbon dioxide, carbon monoxide, hydrogen, methane, and/or pyrolyzed hydrocarbons. The high temperature in section 608C and the generation of drive fluid in the section may increase the pressure of the section so the drive fluids move out of the section into adjacent sections. The increased temperature of section 608C may also provide heat to section 608B through conductive heat transfer and/or convective heat transfer from fluid flow (for example, hydrocarbons and/or drive fluid) to section 608B.

[0916] In some embodiments, hydrocarbons (for example, hydrocarbons produced from section 608C) are provided as a portion of the drive fluid. The injected hydrocarbons may include at least some pyrolyzed hydrocarbons such as pyrolyzed hydrocarbons produced from section 608C. In some embodiments, steam or water are provided as a portion of the drive fluid. Steam or water in the drive fluid may be used to control temperatures in the formation. For example, steam or water may be used to keep temperatures lower in the formation. In some embodiments, water injected as the drive fluid is turned into steam in the formation due to the higher temperatures in the formation. The conversion of water to steam may be used to reduce temperatures or maintain lower temperatures in the formation.

[0917] Fluids injected in section 608C may flow towards section 608B, as shown by the arrows in FIG. 106. Fluid movement through the formation transfers heat convectively

through hydrocarbon layer **388** into sections **608B** and/or **608A**. In addition, some heat may transfer conductively through the hydrocarbon layer between the sections.

[0918] Low level heating of section **608B** mobilizes hydrocarbons in the section. The mobilized hydrocarbons in section **608B** may be moved by the injected fluid through the section towards section **608A**, as shown by the arrows in FIG. **106**. Thus, the injected fluid is pushing hydrocarbons from section **608C** through section **608B** to section **608A**. Mobilized hydrocarbons may be upgraded in section **608A** due to the higher temperatures in the section. Pyrolyzed hydrocarbons that move into section **608A** may also be further upgraded in the section. The upgraded hydrocarbons may be produced through production wells located in section **608A**.

[0919] In certain embodiments, at least some hydrocarbons in section **608B** are mobilized and drained from the section prior to injecting the fluid into the formation. Some formations may have high oil saturation (for example, the Grosmont formation has high oil saturation). The high oil saturation corresponds to low gas permeability in the formation that may inhibit fluid flow through the formation. Thus, mobilizing and draining (removing) some oil (hydrocarbons) from the formation may create gas permeability for the injected fluids.

[0920] Fluids in hydrocarbon layer **388** may preferentially move horizontally within the hydrocarbon layer from the point of injection because tar sands tend to have a larger horizontal permeability than vertical permeability. The higher horizontal permeability allows the injected fluid to move hydrocarbons between sections preferentially versus fluids draining vertically due to gravity in the formation. Providing sufficient fluid pressure with the injected fluid may ensure that fluids are moved to section **608A** for upgrading and/or production.

[0921] In certain embodiments, section **608B** has a larger volume than section **608A** and/or section **608C**. Section **608B** may be larger in volume than the other sections so that more hydrocarbons are produced for less energy input into the formation. Because less heat is provided to section **608B** (the section is heated to lower temperatures), having a larger volume in section **608B** reduces the total energy input to the formation per unit volume. The desired volume of section **608B** may depend on factors such as, but not limited to, viscosity, oil saturation, and permeability. In addition, the degree of coking is much less in section **608B** due to the lower temperature so less hydrocarbons are coked in the formation when section **608B** has a larger volume. In some embodiments, the lower degree of heating in section **608B** allows for cheaper capital costs as lower temperature materials (cheaper materials) may be used for heaters used in section **608B**.

[0922] Certain types of formations have low initial permeabilities and high initial viscosities that inhibit these formations from being easily treated using conventional steam drive processes such as SAGD or CSS. For example, carbonate formations (such as the Grosmont reservoir in Alberta, Canada) have low permeabilities and high viscosities that make these formations unsuitable for conventional steam drive processes. Carbonate formations may also be highly heterogenous (for example, have highly different vertical and horizontal permeabilities), which makes it difficult to control flow of fluids (such as steam) through the formation. In addition, some carbonate formations are relatively shallow formations with low overburden fracture pressures that inhibit the use of high pressure steam injection because of the need to avoid breaking or fracturing the overburden.

[0923] In certain embodiments, formations with the above properties (such as the Grosmont reservoir or other carbonate formations) are treated using a combination of heating from heaters and steam drive processes. FIG. **107** depicts an embodiment for treating a formation with heaters in combination with one or more steam drive processes. Heater **412A** is located in hydrocarbon containing layer **388** between injection well **602** and production well **206**. Injection well **602** and/or production well **206** may be used to inject steam and produce hydrocarbons in a steam drive process, such as a SAGD (steam assisted gravity drainage) process. In certain embodiments, heater **412A** is located substantially horizontally in layer **388**. In some embodiments, injection well **602** and/or production well **206** are located substantially horizontally in layer **388**.

[0924] In certain embodiments, heater **412A** is located approximately vertically equidistant between injection well **602** and production well **206** (the heater is at or near the midpoint between the injection well and the production well). Heater **412A** may provide heat to a portion of layer **388** surrounding the heater and proximate injection well **602** and production well **206**. In some embodiments, heater **412A** is an electric heater such as an insulated conductor heater or a conductor-in-conduit heater. In certain embodiments, heat provided by heater **412A** increases the steam injectivity in the portion surrounding the heater. In certain embodiments, heater **412A** provides heat at high heat injection rates such as those used for the in situ heat treatment process (for example, heat injection rates of at least about 1000 W/m).

[0925] As shown in FIG. **107**, in certain embodiments, heater **412B** is located below injection/production well **610**. In certain embodiments, heater **412B** is located substantially horizontally in layer **388**. In some embodiments, injection/production well **610** is located substantially horizontally in layer **388**. In some embodiments, injection/production well **610** is located substantially vertically in layer **388**. In some embodiments, injection/production well **610** includes multiple wells located substantially vertically in layer **388**.

[0926] In certain embodiments, injection/production well **610** is at least partially offset from heater **412B**. Injection/production well **610** may be used to inject steam and produce hydrocarbons in a cyclic steam drive process, such as a CSS (cyclic steam injection) process. Heater **412B** may provide heat to a portion of layer **388** surrounding the heater and proximate injection/production well **610**. In some embodiments, heater **412B** is an electric heater such as an insulated conductor heater or a conductor-in-conduit heater. In certain embodiments, heat provided by heater **412B** increases the steam injectivity in the portion surrounding the heater. In certain embodiments, heater **412B** provides heat at high heat injection rates such as those used for the in situ heat treatment process (for example, heat injection rates of at least about 1000 W/m).

[0927] In certain embodiments, layer **388** has different initial vertical and horizontal permeabilities (the initial permeability is heterogenous). In one embodiment, the initial vertical permeability in layer **388** is at most about 300 millidarcy and the initial horizontal permeability is at most about 1 darcy. Typically in carbonate formations, the initial vertical permeability is less than the initial horizontal permeability such as, for example, in the Grosmont reservoir in Alberta, Canada. The initial vertical and initial horizontal permeabilities may vary depending on the location in the formation and/or the type of formation. In one embodiment, layer **388**

has an initial viscosity of at least about 1×10^6 centipoise (cp). The initial viscosity may vary depending on the location or depth in the formation and/or the type of formation.

[0928] Typically, these initial permeabilities and initial viscosities are not favorable for steam injection into layer 388 because the steam injection pressure needed to get steam to move hydrocarbons through the formation is above the fracture pressure of overburden 400. Staying below the overburden fracture pressure may be especially difficult for shallower formations such as the Grosmont reservoir because the overburden fracture pressure is relatively small in such shallower formations. In certain embodiments, heater 412A and/or heater 412B are used to provide heat to layer 388 to increase the permeability and reduce the viscosity in the portion surrounding the heater such that steam injected into the layer at pressures below the overburden fracture pressure can move hydrocarbons in the layer. Thus, providing heat to the layer increases the steam injectivity in the layer.

[0929] In certain embodiments, a selected amount of heat, or selected amount of heating time, is provided from heater 412A and/or heater 412B to increase the permeability and reduce the viscosity in layer 388 before steam injection through injection well 602 or injection/production well 610 begins. In some embodiments, a simulation of reservoir conditions is used to assess or determine the selected amount of heat, or heating time, needed before steam injection into layer 388. For example, the selected amount of heating time for heater 412A may be about 1 year for layer 388 to have permeabilities and viscosities suitable for steam injection (sufficient steam injectivity is created in the layer) through injection well 602. The selected amount of heating time for heater 412B may be about 1 year for layer 388 to have permeabilities and viscosities suitable for steam injection (sufficient steam injectivity is created in the layer) through injection/production well 610.

[0930] In certain embodiments, heater 412A is turned off before steam injection begins. In other embodiments, heater 412A is turned off after steam injection begins. In some embodiments, heater 412A is turned off a selected amount of time after steam injection begins. The time the heater is turned off may be selected to provide, for example, desired properties in the hydrocarbons produced from the formation.

[0931] In certain embodiments, heater 412B remains on for a selected amount of time after steam injection/hydrocarbon production through injection/production well 610 begins. Heater 412B may remain on to maintain steam injectivity in the portion surrounding the heater and injection/production well 610. In some embodiments, heat provided from heater 412B increases the size of the portion with increased steam injectivity. After a period of time, heat provided from heater 412B may create steam injection interconnectivity between injection/production well 610 and production well 206. After interconnectivity between injection/production well 610 and production well 206 is achieved, heater 412B may be turned off.

[0932] Interconnectivity between injection/production well 610 and production well 206 allows steam injection from the injection/production well to move hydrocarbons to the production well. This hydrocarbon movement may increase the efficiency of steam injection and hydrocarbon production from the layer. The interconnectivity may also allow less injection wells and/or production wells to be used in treating the layer.

[0933] In certain embodiments, heating from heater 412A and/or heater 412B is controlled and/or turned off at a time to inhibit coke formation in the layer. Simulation of reservoir conditions may be used to determine when/if the onset of coking may occur in the layer. Additionally, steam injection into the formation may assist in inhibiting coke formation in the layer.

[0934] In certain embodiments, steam is injected through injection well 602 at or about the same pressure as steam is injected through injection/production well 610. In certain embodiments, steam is injected through injection well 602 and/or injection/production well 610 at a pressure that is above the formation fracturing pressure but below the overburden fracture pressure. Injecting steam above the formation fracturing pressure may increase the permeability and/or move steam or hydrocarbons through the formation at higher rates. Thus, injecting steam above the formation fracturing pressure may increase the rate of hydrocarbon production through production well 206 and/or injection/production well 610. Injecting steam below the overburden fracture pressure inhibits the steam from fracturing the overburden and allowing formation fluids to escape to the surface through the overburden (for example, maintains the integrity of the overburden).

[0935] In some embodiments, a pattern for treating a formation includes a repeating pattern of heaters 412A, 412B, injection well 602, production well 206, and injection/production well 610, as shown in FIG. 107. The pattern may be repeated horizontally and/or vertically in the formation. Using the repeating pattern to treat the formation may reduce the number of wells needed to treat the formation as compared to using typical steam drive processes or in situ heat treatment processes individually. In some embodiments, heaters 412A, 412B may be removed and reused in another portion of the formation, or another formation, after the heaters are turned off. The heaters may be allowed to cool down before being removed from the formation.

[0936] Using the embodiment depicted in FIG. 107 to treat the formation (for example, the Grosmont reservoir) may increase oil production and/or decrease the amount of steam needed for oil production as compared to using the SAGD process only. FIG. 108 depicts a comparison treating the formation using the embodiment depicted in FIG. 107 and treating the formation using the SAGD process. Cumulative oil production, cumulative steam-oil ratio, and top pressure for the formation are compared using the two techniques. Plot 612 depicts cumulative oil production for the embodiment depicted in FIG. 107. Plot 614 depicts cumulative oil production for the SAGD process. Plot 616 depicts cumulative steam-oil ratio for the embodiment depicted in FIG. 107. Plot 618 depicts cumulative steam-oil ratio for the SAGD process. Plot 620 depicts top pressure for the embodiment depicted in FIG. 107. Plot 622 depicts top pressure for the SAGD process. As shown in FIG. 108, cumulative oil production is significantly increased for the embodiment depicted in FIG. 107 while the steam-oil ratio is slightly decreased and the top pressure is substantially the same. Thus, the embodiment depicted in FIG. 107 is more efficient in producing oil than the SAGD process.

[0937] In some embodiments, karsted formations or karsted layers in formations have vugs in one or more layers of the formations. The vugs may be filled with viscous fluids such as bitumen or heavy oil. In some embodiments, the karsted layers have a porosity of at least about 20 porosity

units, at least about 30 porosity units, or at least about 35 porosity units. The karsted formation may have a porosity of at most about 15 porosity units, at most about 10 porosity units, or at most about 5 porosity units. Vugs filled with viscous fluids may inhibit steam or other fluids from being injected into the formation or the layers. In certain embodiments, the karsted formation or karsted layers of the formation are treated using the in situ heat treatment process.

[0938] Heating of these formations or layers may decrease the viscosity of the viscous fluids in the vugs and allow the fluids to drain (for example, mobilize the fluids). Formations with karsted layers may have sufficient permeability so that when the viscosity of fluids (hydrocarbons) in the formation is reduced, the fluids drain and/or move through the formation relatively easily (for example, without a need for creating higher permeability in the formation).

[0939] In some embodiments, the relative amount (the degree) of karst in the formation is assessed using techniques known in the art (for example, 3D seismic imaging of the formation). The assessment may give a profile of the formation showing layers or portions with varying amounts of karst in the formation. In certain embodiments, more heat is provided to selected karsted portions of the formation than other karsted portions of the formation. In some embodiments, selective amounts of heat are provided to portions of the formation as a function of the degree of karst in the portions. Amounts of heat may be provided by varying the number and/or density of heaters in the portions with varying degrees of karst.

[0940] In certain embodiments, the hydrocarbon fluids in karsted portions have higher viscosities than hydrocarbons in other non-karsted portions of the formation. Thus, more heat may be provided to the karsted portions to reduce the viscosity of the hydrocarbons in the karsted portions.

[0941] In certain embodiments, only the karsted layers of the formation are treated using the in situ heat treatment process. Other non-karsted layers of the formation may be used as seals for the in situ heat treatment process. For example, karsted layers with different quantities of hydrocarbons in the layers may be treated while other layers are used as natural seals for the treatment process. In some embodiments, karsted layers with low quantities of hydrocarbons as compared to the other karsted and/or non-karsted layers are used as seals for the treatment process. The quantity of hydrocarbons in the Karsted layer may be determined using logging methods and/or Dean Stark distillation methods. The quantity of hydrocarbons may be reported as a volume percent of hydrocarbons per volume percent of rock, or as volume of hydrocarbons per mass of rock.

[0942] In some embodiments, karsted layers with fewer hydrocarbons are treated along with karsted layers with more hydrocarbons. In some embodiments, karsted layers with fewer hydrocarbons are above and below a karsted layer with more hydrocarbons (the middle karsted layer). Less heat may be provided to the upper and lower karsted layers than the middle karsted layer. Less heat may be provided in the upper and lower karsted layers by having greater heat spacing and/or less heaters in the upper and lower karsted layers as compared to the middle karsted layer. In some embodiments, less heating of the upper and lower karsted layers includes heating the layers to mobilization and/or visbreaking temperatures, but not to pyrolysis temperatures. In some embodiments, the

upper and/or lower karsted layers are heated with heaters and the residual heat from the upper and/or lower layers transfers to the middle layer.

[0943] One or more production wells may be located in the middle karsted layer. Mobilized and/or visbroken hydrocarbons from the upper karsted layer may drain to the production wells in the middle karsted layer. Heat provided to the lower karsted layer may create a thermal expansion drive and/or a gas pressure drive in the lower karsted layer. The thermal expansion and/or gas pressure may drive fluids from the lower karsted layer to the middle karsted layer. These fluids may be produced through the production wells in the middle karsted layer. Providing some heat to the upper and lower karsted layers may increase the total recovery of fluids from the formation by, for example, 25% or more.

[0944] In some embodiments, the karsted layers with fewer hydrocarbons are further heated to pyrolysis temperatures after production from the karsted layer with more hydrocarbons is completed or almost completed. The karsted layers with fewer hydrocarbons may also be further treated by producing fluids through production wells located in the layers.

[0945] In some embodiments, a drive process, a solvent injection process and/or a pressurizing fluid process is used after the in situ heat treatment of the karsted formation or karsted layers. A drive process may include injection of a drive fluid such as steam. A drive process includes, but is not limited to, a steam injection process such as cyclic steam injection, a steam assisted gravity drainage process (SAGD), and a vapor solvent and SAGD process. A drive process may drive fluids from one portion of the formation towards a production well.

[0946] A solvent injection process may include injection of a solvating fluid. A solvating fluid includes, but is not limited to, water, emulsified water, hydrocarbons, surfactants, alkaline water solutions (for example, sodium carbonate solutions), caustic, polymers, carbon disulfide, carbon dioxide, or mixtures thereof. The solvation fluid may mix with, solvate and/or dilute the hydrocarbons to form a mixture of condensable hydrocarbons and solvation fluids. The mixture may have a reduced viscosity as compared to the initial viscosity of the fluids in the formation. The mixture may flow and/or be mobilized towards production wells in the formation.

[0947] A pressurizing process may include moving hydrocarbons in the formation by injection of a pressurized fluid. The pressurizing fluid may include, but is not limited to, carbon dioxide, nitrogen, steam, methane, and/or mixtures thereof.

[0948] In some embodiments, the drive process (for example, the steam injection process) is used to mobilize fluids before the in situ heat treatment process. Steam injection may be used to get hydrocarbons (oil) away from rock or other strata in the formation. The steam injection may mobilize the hydrocarbons without significantly heating the rock.

[0949] In some embodiments, fluid injected in the formation (for example, steam and/or carbon dioxide) may absorb heat from the formation and cool the formation depending on the pressure in the formation and the temperature of the injected fluid. In some embodiments, the injected fluid is used to recover heat from the formation. The recovered heat may be used in surface processing fluids and/or to preheat other portions of the formation using the drive process.

[0950] In some embodiments, heaters are used to preheat the karsted formation or karsted layers to create injectivity in the formation. In situ heat treatment of karsted formations

and/or karsted layers may allow for drive fluid injection, solvent injection and/or pressurizing fluid injection where it was previously unfavorable or unmanageable. Typically, karsted formations were unfavorable for drive processes because channeling of the fluid injected in the formation inhibited pressure build-up in the formation. In situ heat treatment of karsted formations may allow for injection of a drive fluid, a solvent and/or a pressurizing fluid by reducing the viscosity of hydrocarbons in the formation and allowing pressure to build in the formations without significant bypass of the fluid through channels in the formations. For example, heating a section of the formation using in situ heat treatment may heat and mobilize heavy hydrocarbons (bitumen) by reducing the viscosity of the heavy hydrocarbons in the karsted layer. Some of the heated less viscous heavy hydrocarbons may flow from the karsted layer into other portions of the formation that are cooler than the heated karsted portion. The heated less viscous heavy hydrocarbons may flow through channels and/or fractures. The heated heavy hydrocarbons may cool and solidify in the channels, thus creating a temporary seal for the drive fluid, solvent, and/or pressurizing fluid.

[0951] In certain embodiments, the karsted formation or karsted layers are heated to temperatures below the decomposition temperature of minerals in the formation (for example, rock minerals such as dolomite and/or clay minerals such as kaolinite, illite, or smectite). In some embodiments, the karsted formation or karsted layers are heated to temperatures of at most 400° C., at most 450° C., or at most 500° C. (for example, to a temperature below a dolomite decomposition temperature at formation pressure). In some embodiments, the karsted formation or karsted layers are heated to temperatures below a decomposition temperature of clay minerals (such as kaolinite) at formation pressure.

[0952] In some embodiments, heat is preferentially provided to portions of the formation with low weight percentages of clay minerals (for example, kaolinite) as compared to the content of clay in other portions of the formation. For example, more heat may be provided to portions of the formation with at most 1% by weight clay minerals, at most 2% by weight clay minerals, or at most 3% by weight clay minerals than portions of the formation with higher weight percentages of clay minerals. In some embodiments, the rock and/or clay mineral distribution is assessed in the formation prior to designing a heater pattern and installing the heaters. The heaters may be arranged to preferentially provide heat to the portions of the formation that have been assessed to have lower weight percentages of clay minerals as compared to other portions of the formation. In certain embodiments, the heaters are placed substantially horizontally in layers with low weight percentages of clay minerals.

[0953] Providing heat to portions of the formation with low weight percentages of clay minerals may minimize changes in the chemical structure of the clays. For example, heating clays to high temperatures may drive water from the clays and change the structure of the clays. The change in structure of the clay may adversely affect the porosity and/or permeability of the formation. If the clays are heated in the presence of air, the clays may oxidize and the porosity and/or permeability of the formation may be adversely affected. Portions of the formation with a high weight percentage of clay minerals may be inhibited from reaching temperatures above temperatures that effect the chemical composition of the clay minerals at formation pressures. For example, portions of the forma-

tion with large amounts of kaolinite relative to other portions of the formation may be inhibited from reaching temperatures above 240° C. In some embodiments, portions of the formation with a high quantity of clay minerals relative to other portions of the formation may be inhibited from reaching temperatures above 200° C., above 220° C., above 240° C., or above 300° C.

[0954] In some embodiments, karsted formations may include water. Minerals (for example, carbonate minerals) in the formation may at least partially dissociate in the water to form carbonic acid. The concentration of carbonic acid in the water may be sufficient to make the water acidic. At pressure greater than ambient formation pressures, dissolution of minerals in the water may be enhanced, thus formation of acidic water is enhanced. Acidic water may react with other minerals in the formation such as dolomite ($\text{MgCa}(\text{CO}_3)_2$) and increase the solubility of the minerals. Water at lower pressures, or non-acidic water, may not solubilize the minerals in the formation. Dissolution of the minerals in the formation may form fractures in the formation. Thus, controlling the pressure and/or the acidity of water in the formation may control the solubilization of minerals in the formation. In some embodiments, other inorganic acids in the formation enhance the solubilization of minerals such as dolomite.

[0955] In some embodiments, the karsted formation or karsted layers are heated to temperatures above the decomposition temperature of minerals in the formation. At temperatures above the minerals decomposition temperature, the minerals may decompose to produce carbon dioxide or other products. The decomposition of the minerals and the carbon dioxide production may create permeability in the formation and mobilize viscous fluids in the formation. In some embodiments, the produced carbon dioxide is maintained in the formation to generate a gas cap in the formation. The carbon dioxide may be allowed to rise to the upper portions of the karsted layers to generate the gas cap.

[0956] In some embodiments, the production front of the drive process follows behind the heat front of the in situ heat treatment process. In some embodiments, areas behind the production front are further heated to produce more fluids from the formation. Further heating behind the production front may also maintain the gas cap behind the production front and/or maintain quality in the production front of the drive process.

[0957] In certain embodiments, the drive process is used before the in situ heat treatment of the formation. In some embodiments, the drive process is used to mobilize fluids in a first section of the formation. The mobilized fluids may then be pushed into a second section by heating the first section with heaters. Fluids may be produced from the second section. In some embodiments, the fluids in the second section are pyrolyzed and/or upgraded using the heaters.

[0958] In formations with low permeabilities, the drive process may be used to create a "gas cushion" or pressure sink before the in situ heat treatment process. The gas cushion may inhibit pressures from increasing quickly to fracture pressure during the in situ heat treatment process. The gas cushion may provide a path for gases to escape or travel during early stages of heating during the in situ heat treatment process.

[0959] In some embodiments, the drive process (for example, the steam injection process) is used to mobilize fluids before the in situ heat treatment process. Steam injection may be used to get hydrocarbons (oil) away from rock or

other strata in the formation. The steam injection may mobilize the oil without significantly heating the rock.

[0960] In some embodiments, injection of a fluid (for example, steam or carbon dioxide) may consume heat in the formation and cool the formation depending on the pressure in the formation. In some embodiments, the injected fluid is used to recover heat from the formation. The recovered heat may be used in surface processing fluids and/or to preheat other portions of the formation using the drive process.

[0961] FIG. 109 depicts an embodiment for heating and producing from the formation with the temperature limited heater in a production wellbore. Production conduit 624 is located in wellbore 490. In certain embodiments, a portion of wellbore 490 is located substantially horizontally in formation 492. In some embodiments, the wellbore is located substantially vertically in the formation. In an embodiment, at least a portion of wellbore 490 is an open wellbore (an uncased wellbore). In some embodiments, the wellbore has a casing or liner with perforations or openings to allow fluid to flow into the wellbore.

[0962] Conduit 624 may be made from carbon steel or more corrosion resistant materials such as stainless steel. Conduit 624 may include apparatus and mechanisms for gas lifting or pumping produced oil to the surface. For example, conduit 624 includes gas lift valves used in a gas lift process. Examples of gas lift control systems and valves are disclosed in U.S. Pat. No. 6,715,550 to Vinegar et al. and U.S. Pat. No. 7,259,688 to Hirsch et al., and U.S. Patent Application Publication No. 2002-0036085 to Bass et al., each of which is incorporated by reference as if fully set forth herein. Conduit 624 may include one or more openings (perforations) to allow fluid to flow into the production conduit. In certain embodiments, the openings in conduit 624 are in a portion of the conduit that remains below the liquid level in wellbore 490. For example, the openings are in a horizontal portion of conduit 624.

[0963] Heater 412 is located in conduit 624. In some embodiments, heater 412 is located outside conduit 624, as shown in FIG. 110. The heater located outside the production conduit may be coupled (strapped) to the production conduit. In some embodiments, more than one heater (for example, two, three, or four heaters) are placed about conduit 624. The use of more than one heater may reduce bowing or flexing of the production conduit caused by heating on only one side of the production conduit. In an embodiment, heater 412 is a temperature limited heater. Heater 412 provides heat to reduce the viscosity of fluid (such as oil or hydrocarbons) in and near wellbore 490. In certain embodiments, heater 412 raises the temperature of the fluid in wellbore 490 up to a temperature of 250° C. or less (for example, 225° C., 200° C., or 150° C.). Heater 412 may be at higher temperatures (for example, 275° C., 300° C., or 325° C.) because the heater provides heat to conduit 624 and there is some temperature differential between the heater and the conduit. Thus, heat produced from the heater does not raise the temperature of fluids in the wellbore above 250° C.

[0964] In certain embodiments, heater 412 includes ferromagnetic materials such as Carpenter Temperature Compensator "32", Alloy 42-6, Alloy 52, Invar 36, or other iron-nickel or iron-nickel-chromium alloys. In certain embodiments, nickel or nickel-chromium alloys are used in heater 412. In some embodiments, heater 412 includes a composite conductor with a more highly conductive material such as copper on the inside of the heater to improve the turndown ratio of the

heater. Heat from heater 412 heats fluids in or near wellbore 490 to reduce the viscosity of the fluids and increase a production rate through conduit 624.

[0965] In certain embodiments, portions of heater 412 above the liquid level in wellbore 490 (such as the vertical portion of the wellbore depicted in FIGS. 109 and 110) have a lower maximum temperature than portions of the heater located below the liquid level. For example, portions of heater 412 above the liquid level in wellbore 490 may have a maximum temperature of 100° C. while portions of the heater located below the liquid level have a maximum temperature of 250° C. In certain embodiments, such a heater includes two or more ferromagnetic sections with different Curie temperatures and/or phase transformation temperature ranges to achieve the desired heating pattern. Providing less heat to portions of wellbore 490 above the liquid level and closer to the surface may save energy.

[0966] In certain embodiments, heater 412 is electrically isolated on the outside surface of the heater and allowed to move freely in conduit 624. In some embodiments, electrically insulating centralizers are placed on the outside of heater 412 to maintain a gap between conduit 624 and the heater.

[0967] In some embodiments, heater 412 is cycled (turned on and off) so that fluids produced through conduit 624 are not overheated. In an embodiment, heater 412 is turned on for a specified amount of time until a temperature of fluids in or near wellbore 490 reaches a desired temperature (for example, the maximum temperature of the heater). During the heating time (for example, 10 days, 20 days, or 30 days), production through conduit 624 may be stopped to allow fluids in the formation to "soak" and obtain a reduced viscosity. After heating is turned off or reduced, production through conduit 624 is started and fluids from the formation are produced without excess heat being provided to the fluids. During production, fluids in or near wellbore 490 will cool down without heat from heater 412 being provided. When the fluids reach a temperature at which production significantly slows down, production is stopped and heater 412 is turned back on to reheat the fluids. This process may be repeated until a desired amount of production is reached. In some embodiments, some heat at a lower temperature is provided to maintain a flow of the produced fluids. For example, low temperature heat (for example, 100° C., 125° C., or 150° C.) may be provided in the upper portions of wellbore 490 to keep fluids from cooling to a lower temperature.

[0968] In some embodiments, a temperature limited heater positioned in a wellbore heats steam that is provided to the wellbore. The heated steam may be introduced into a portion of the formation. In certain embodiments, the heated steam may be used as a heat transfer fluid to heat a portion of the formation. In some embodiments, the steam is used to solution mine desired minerals from the formation. In some embodiments, the temperature limited heater positioned in the wellbore heats liquid water that is introduced into a portion of the formation.

[0969] In an embodiment, the temperature limited heater includes ferromagnetic material with a selected Curie temperature and/or a selected phase transformation temperature range. The use of a temperature limited heater may inhibit a temperature of the heater from increasing beyond a maximum selected temperature (for example, a temperature at or about the Curie temperature and/or the phase transformation temperature range). Limiting the temperature of the heater may

inhibit potential burnout of the heater. The maximum selected temperature may be a temperature selected to heat the steam to above or near 100% saturation conditions, superheated conditions, or supercritical conditions. Using a temperature limited heater to heat the steam may inhibit overheating of the steam in the wellbore. Steam introduced into a formation may be used for synthesis gas production, to heat the hydrocarbon containing formation, to carry chemicals into the formation, to extract chemicals or minerals from the formation, and/or to control heating of the formation.

[0970] A portion of the formation where steam is introduced or that is heated with steam may be at significant depths below the surface (for example, greater than about 1000 m, about 2500 m, or about 5000 m below the surface). If steam is heated at the surface of the formation and introduced to the formation through a wellbore, a quality of the heated steam provided to the wellbore at the surface may have to be relatively high to accommodate heat losses to the wellbore casing and/or the overburden as the steam travels down the wellbore. Heating the steam in the wellbore may allow the quality of the steam to be significantly improved before the steam is provided to the formation. A temperature limited heater positioned in a lower section of the overburden and/or adjacent to a target zone of the formation may be used to controllably heat steam to improve the quality of the steam injected into the formation and/or inhibit condensation along the length of the heater. In certain embodiments, the temperature limited heater improves the quality of the steam injected and/or inhibits condensation in the wellbore for long steam injection wellbores (especially for long horizontal steam injection wellbores).

[0971] A temperature limited heater positioned in a wellbore may be used to heat the steam to above or near 100% saturation conditions or superheated conditions. In some embodiments, a temperature limited heater may heat the steam so that the steam is above or near supercritical conditions. The static head of fluid above the temperature limited heater may facilitate producing 100% saturation, superheated, and/or supercritical conditions in the steam. Supercritical or near supercritical steam may be used to strip hydrocarbon material and/or other materials from the formation. In certain embodiments, steam introduced into the formation may have a high density (for example, a specific gravity of about 0.8 or above). Increasing the density of the steam may improve the ability of the steam to strip hydrocarbon material and/or other materials from the formation.

[0972] In some embodiments, the tar sands formation may be treated by the in situ heat treatment process to produce pyrolyzed product from the formation. A significant amount of carbon in the form of coke may remain in tar sands formation when production of pyrolysis product from the formation is complete. In some embodiments, the coke in the formation may be utilized to produce heat and/or additional products from the heated coke containing portions of the formation.

[0973] In some embodiments, air, oxygen enriched air, and/or other oxidants may be introduced into the treatment area that has been pyrolyzed to react with the coke in the treatment area. The temperature of the treatment area may be sufficiently hot to support burning of the coke without additional energy input from heaters. The oxidation of the coke may significantly heat the portion of the formation. Some of the heat may transfer to portions of the formation adjacent to the treatment area. The transferred heat may mobilize fluids in portions of the formation adjacent to the treatment area. The

mobilized fluids may flow into and be produced from production wells near the perimeter of the treatment area.

[0974] Gases produced from the formation heated by combusting coke in the formation may be at high temperature. The hot gases may be utilized in an energy recovery cycle (for example, a Kalina cycle or a Rankine cycle) to produce electricity.

[0975] The air, oxygen enriched air and/or other oxidants may be introduced into the formation for a sufficiently long period of time to heat a portion of the treatment area to a desired temperature sufficient to allow for the production of synthesis gas of a desired composition. The temperature may be from 500° C. to about 1000° C. or higher. When the temperature of the portion is at or near the desired temperature, a synthesis gas generating fluid, such as water, may be introduced into the formation to result in the formation of synthesis gas. Synthesis gas produced from the formation may be sent to a treatment facility and/or be sent through a pipeline to a desired location. During introduction of the synthesis gas generating fluid, the introduction of air, oxygen enriched air, and/or other oxidants may be stopped, reduced, or maintained. If the temperature of the formation reduces so that the synthesis gas produced from the formation does not have the desired composition, introduction of the synthesis gas generating fluid may be stopped or reduced, and the introduction of air, enriched air and/or other oxidants may be started or increased so that oxidation of coke in the formation reheats portions of the treatment area. The introduction of oxidant to heat the formation and the introduction of synthesis gas generating fluid to produce synthesis gas may be cycled until all or a significant portion of the treatment area is treated.

[0976] In certain embodiments, a subsurface formation is treated in stages. The treatment may be initiated with electrical heating with further heating generated from oxidation of hydrocarbons and hot gas production from the formation. Hydrocarbons (e.g., heavy hydrocarbons and/or bitumen) may be moved from one portion of the formation to another where the hydrocarbons are produced from the formation. By using a combination of heaters, oxidizing fluid and/or drive fluid, the overall time necessary to initiate production from a formation may be decreased relative to times necessary to initiate production using heaters and/or drive processes alone. By controlling a rate of oxidizing fluid injection and/or drive fluid injection in conjunction with heating with heaters, a relatively uniform temperature distribution may be obtained in sections (portions) of the subsurface formation.

[0977] A method for treating a hydrocarbon containing formation with heaters in combination with an oxidizing fluid may include providing heat to a first portion of the formation from a plurality of heaters located in heater wells in the first portion. Fluids may be produced through one or more production wells in a second portion of the formation that is substantially adjacent to the first portion. The heat provided to the first portion may be reduced or turned off after a selected time. An oxidizing fluid may be provided through one or more of the heater wells in the first portion. Heat may be provided to the first portion and the second portion through oxidation of at least some hydrocarbons in the first portion. Fluids may be produced through at least one of the production wells in the second portion. The fluids may include at least some oxidized hydrocarbons. Transportation fuel may be produced from the hydrocarbons produced from the first and/or second of the formation.

[0978] FIG. 111 depicts a schematic of an embodiment of a first stage of treating the tar sands formation with electrical heaters. Hydrocarbon layer 388 may be separated into section 608A and section 608B. Heaters 412 may be located in section 608A. Production wells 206 may be located in section 608B. In some embodiments, production wells 206 extend into section 608A.

[0979] Heaters 412 may be used to heat and treat portions of section 608A through conductive, convective, and/or radiative heat transfer. For example, heaters 412 may mobilize, visbreak, and/or pyrolyze hydrocarbons in section 608A. Production wells 206 may be used to produce mobilized, visbroken, and/or pyrolyzed hydrocarbons from section 608A.

[0980] FIG. 112 depicts a schematic of an embodiment of a second stage of treating the tar sands formation with fluid injection and oxidation. After at least some hydrocarbons from section 608A have been produced (for example, a majority of hydrocarbons in the section or almost all producible hydrocarbons in the section), the heater wells in section 608A may be converted to injection wells 602. In some embodiments, the heater wells are open wellbores below the overburden. In some embodiments, the heater wells are initially installed into wellbores that include perforated casings. In some embodiments, the heater wells are perforated using perforation guns after heating from the heater wells is completed.

[0981] Injection wells 602 may be used to inject an oxidizing fluid (for example, air, oxygen, enriched air, or other oxidants) into the formation. In some embodiments, the oxidation includes liquid water and/or steam. The amount of oxidizing fluid may be controlled to adjust subsurface combustion patterns. In some embodiments, carbon dioxide or other fluids are injected into the formation to control heating/production in the formation. The oxidizing fluid may oxidize (combust) or otherwise react with hydrocarbons remaining in the formation (for example, coke). Water in the oxidizing fluid may react with coke and/or hydrocarbons in the hot formation to produce syngas in the formation. Production wells 206 in section 608B may be converted to heater/gas production wells 626. Heater/gas production wells 626 may be used to produce oxidation gases and/or syngas products from the formation. Producing the hot oxidation gases and/or syngas through heater/gas production wells 626 in section 608B may heat the section to higher temperatures so that hydrocarbons in the section are mobilized, visbroken, and/or pyrolyzed in the section. Production wells 206 in section 608C may be used to produce mobilized, visbroken, and/or pyrolyzed hydrocarbons from section 608B.

[0982] In certain embodiments, the pressure of the injected fluids and the pressure in formation are controlled to control the heating in the formation. The pressure in the formation may be controlled by controlling the production rate of fluids from the formation (for example, the production rate of oxidation gases and/or syngas products from heater/gas production wells 626). Heating in the formation may be controlled so that there is enough hydrocarbon volume in the formation to maintain the oxidation reactions in the formation. Heating may be controlled so that the formation near the injection wells is at a temperature that will generate desired synthesis gas if a synthesis gas generating fluid such as water is included in the oxidation fluid. Heating in the formation may also be controlled so that enough heat is generated to conductively heat the formation to mobilize, visbreak, and/or pyrolyze hydrocarbons in adjacent sections of the formation.

[0983] The process of injecting oxidizing fluid and/or water in one section, producing oxidation gases and/or syngas products in an adjacent section to heat the adjacent section, and producing upgraded hydrocarbons (mobilized, visbroken, and/or pyrolyzed hydrocarbons) from a subsequent section may be continued in further sections of the tar sands formation. For example, FIG. 113 depicts a schematic of an embodiment of a third stage of treating the tar sands formation with fluid injection and oxidation. The gas heater/producer wells in section 608B are converted to injection wells 602 to inject air and/or water. The producer wells in section 608C are converted to production wells (for example, heater/gas production wells 626) to produce oxidation gases and/or syngas products. Production wells 206 are formed in section 608D to produce upgraded hydrocarbons.

[0984] In some embodiments, significant amounts of residue and/or coke remain in a subsurface formation after heating the formation with heaters and producing formation fluids from the formation. In some embodiments, sections of the formation include heavy hydrocarbons such as bitumen that are difficult to heat to mobilization temperatures adjacent to sections of the formation that are being treated using an in situ heat treatment process. Heating of heavy hydrocarbons may require high energy input, a large number of heater wells and/or increase in capital costs (for example, materials for heater construction). It would be advantageous to produce formation fluids from subsurface formations with lower energy costs, fewer heater wells and/or heater cost with improved product quality and/or recovery efficiency.

[0985] In some embodiments, a method for treating a subsurface formation includes producing a at least a third hydrocarbons from a first portion by an in situ heat treatment process. An average temperature of the first portion is less than 350° C. An oxidizing fluid may be injected in the first portion to cause the average temperature in the first portion to increase sufficiently to oxidize hydrocarbon in the first portion and to raise the average temperature in the first portion to greater than 350° C. In some embodiments, the temperature of the first portion is raised to an average temperature ranging from 350° C. to 700° C. A heavy hydrocarbon fluid that includes one or more condensable hydrocarbons may be injected in the first portion to from a diluent and/or drive fluid. In some embodiments, a catalyst system is added to the first portion.

[0986] FIGS. 114, 115, and 116 depict side view representations of embodiments of treating a subsurface formation in stages with heaters, oxidizing fluid, catalyst, and/or drive fluid. Hydrocarbon layer 388 may be divided into three or more treatment sections. In certain embodiments, hydrocarbon layer 388 includes five treatment sections: section 608A, section 608B, section 608C, section 608D and section 608E. Sections 608A and section 608C are separated by section 608B. Sections 608C and section 608E are separated by section 608D. Section 608A through section 608E may be horizontally displaced from each other in the formation. In some embodiments, one side of section 608A is adjacent to an edge of the treatment area of the formation or an untreated section of the formation is left on one side of section 608A before the same or a different pattern is formed on the opposite side of the untreated section.

[0987] In certain embodiments, section 608A is heated to pyrolysis temperatures with heaters 412. Section 608A may be heated to mobilize and/or pyrolyze hydrocarbons in the section. In some embodiments, section 608A is heated to an

average temperature of 250° C., 300° C., or up to 350° C. The mobilized and/or pyrolyzed hydrocarbons may be produced through one or more production wells 206. Once at least a third, a substantial portion, or all of the hydrocarbons have been produced from section 608A, the temperature in section 608A may be maintained at an average temperature that allows the section to be used as a reactor and/or reaction zone to treat formation fluid and/or hydrocarbons from surface facilities. Use of one or more heated portions of the formation to treat such hydrocarbons may reduce or eliminate the need for surface facilities that treat such fluids (for example, coking units and/or delayed coking units).

[0988] In certain embodiments, heating and producing hydrocarbons from sections 608A creates fluid injectivity in the sections. After fluid injectivity has been created in section 608A, an oxidizing fluid may be injected into the section. For example, oxidizing fluid may be injected in section 608A after at least a third or a majority of the hydrocarbons have been produced from the section. The fluid may be injected through heater wellbores, production wells 206, and/or injection wells located in section 608A. In some embodiments, heaters 412 continue to provide heat while the fluid is being injected. In certain embodiments, heaters 412 may be turned down or off before or during fluid injection.

[0989] During injection of oxidant, excess oxidant and/or oxidation products may be removed from section 608A through one or more production wells 206 and/or heater/gas production wells. In some embodiments, after the formation is raised to a desired temperature, a second fluid may be introduced into section 608A. The second fluid may be water and/or steam. Addition of the second fluid may cool the formation. For example, when the second fluid is steam and/or water, the reactions of the second fluid with coke and/or hydrocarbons are endothermic and produce synthesis gas. In some embodiments, oxidizing fluid is added with the second fluid so that some heating of section 608A occurs simultaneous with the endothermic reactions. In some embodiments, section 608A is treated in alternating steps of adding oxidant and second fluid to heat the formation for selected periods of time.

[0990] In certain embodiments, the pressure of the injected fluids and the pressure section 608A are controlled to control the heating in the formation. The pressure in section 608A may be controlled by controlling the production rate of fluids from the section (for example, the production rate of hydrocarbons, oxidation gases and/or syngas products). Heating in section 608A may be controlled so that section reaches a desired temperature (e.g., temperatures of at least 350° C., of at least about 400° C., or at least about 500° C., about 700° C., or higher). Injection of the oxidizing fluid may allow portions of the formation below the section heated by heaters to be heated, thus allowing heating of formation fluids in deeper and/or inaccessible portions of the formation. The control of heat and pressure in the section may improve efficiency and quality of products produced from the formation.

[0991] During heating and/or after heating of section 608A, heavy hydrocarbons with low economic value and/or waste hydrocarbon streams from surface facilities may be injected in the section. Low economic value hydrocarbons and/or waste hydrocarbon streams may include, but are not limited to, hydrocarbons produced during surface mining operations, residue, bitumen and/or bottom extracts from bitumen mining. In some embodiments, hydrocarbons produced from section 608A or other sections of the formation may be intro-

duced into section 608A. In some embodiments, one or more of the heater wells in section 608A are converted to injection wells.

[0992] Heating of hydrocarbons and/or coke in section 608A may generate drive fluids. Generated drive fluids in section 608A may include air, steam, carbon dioxide, carbon monoxide, hydrogen, methane, pyrolyzed hydrocarbons and/or in situ diluent. In some embodiments, hydrocarbon fluids are introduced into section 608A prior to injecting an oxidizing fluid and/or the second fluid. Oxidation and/or thermal cracking of introduced hydrocarbon fluids may create the drive fluid.

[0993] In some embodiments, drive fluid may be injected into the formation. The addition of oxidizing fluid, steam, and/or water in the drive fluid may be used to control temperatures in section 608A. For example, the addition of hydrocarbons to section 608A may cool the average temperature in section 608A to a temperature below temperatures that allow for cracking of the introduced hydrocarbons. Oxidizing fluid may be injected to increase and/or maintain the average temperature between 250° C. and 700° C. or between 350° C. and 600° C. Maintaining the temperature between 250° C. and 700° C. may allow for the production of high quality hydrocarbons from the low value hydrocarbons and/or waste streams. Controlling the input of hydrocarbons, oxidizing fluid, and/or drive fluid into section 608A may allow for the production of condensable hydrocarbons with a minimal amount non-condensable gases. In some embodiments, controlling the input of hydrocarbons, oxidizing fluid, and/or drive fluid into section 608A may allow for the production of large amounts of non-condensable hydrocarbons and/or hydrogen with minimal amounts of condensable hydrocarbons.

[0994] In some embodiments, a catalyst system is introduced to section 608A when the section is at a desired temperature (for example, a temperature of at least 350° C., at least 400° C., or at least 500° C.). In some embodiments, the section is heated after and/or during introduction of the catalyst system. The catalyst system may be provided to the formation by injecting the catalyst system into one or more injection wells and/or production wells in section 608A. In some embodiments, the catalyst system is positioned in wellbores proximate the section of the formation to be treated. In some embodiments, the catalyst is introduced to one or more sections during in situ heat treatment of the sections. The catalyst may be provided to section 608A as a slurry and/or a solution in sufficient quantity to allow the catalyst to be dispersed in the section. For example, the catalyst system may be dissolved in water and/or slurried in an emulsion of water and hydrocarbons. At temperatures of at least 100° C., at least 200° C., or at least 250° C., vaporization of water from the solution allows the catalyst to be dispersed in the rock matrix of section 608A.

[0995] The catalyst system may include one or more catalysts. The catalysts may be supported or unsupported catalysts. Catalysts include, but are not limited to, alkali metal carbonates, alkali metal hydroxides, alkali metal hydrides, alkali metal amides, alkali metal sulfides, alkali metal acetates, alkali metal oxalates, alkali metal formates, alkali metal pyruvates, alkaline-earth metal carbonates, alkaline-earth metal hydroxides, alkaline-earth metal hydrides, alkaline-earth metal amides, alkaline-earth metal sulfides, alkaline-earth metal acetates, alkaline-earth metal oxalates, alkaline-earth metal formates, alkaline-earth metal pyru-

vates, or commercially available fluid catalytic cracking catalysts, dolomite, silicon-alumina catalyst fines, zeolites, zeolite catalyst fines any catalyst that promotes formation of aromatic hydrocarbons, or mixtures thereof.

[0996] In some embodiments, fractions from surface facilities include catalyst fines. Surface facilities may include catalytic cracking units and/or hydrotreating units. These fractions may be injected in section 608A to provide a source of catalyst for the section. Injection of the fractions in section 608A may provide an advantageous method for disposal and/or upgrading of the fractions as compared to conventional disposal methods for fractions containing catalyst fines.

[0997] After injecting catalyst in section 608A, the average temperature in section 608A may be increased or maintained in a range from about 250° C. to about 700° C., from about 300° C. to about 650° C., or from about 350° C. to about 600° C. by injection of reaction fluids (for example, oxidizing fluid, steam, water and/or combinations thereof). In some embodiments, heaters 412 are used to raise or maintain the temperature in section 608A in the desired range. In some embodiments, heaters 412 and the introduction of reaction fluids into section 608A are used to raise or maintain the temperature in the desired range. Hydrocarbon fluids may be introduced in section 608A once the desired temperature is obtained. In some embodiments, the catalyst system is slurried with a portion of the hydrocarbons, and the slurry is introduced to section 608A. In some embodiments, a portion of the hydrocarbon fluids are introduced to section 608A prior to introduction of the catalyst system. The introduced hydrocarbon fluids may be hydrocarbons in formation fluid from an adjacent portion of the formation, and/or low value hydrocarbons. The hydrocarbons may contact the catalyst system to produce desirable hydrocarbons (for example, visbroken hydrocarbons, cracked hydrocarbons, aromatic hydrocarbons, or mixtures thereof). The desired temperature in section 608A may be maintained by turning on heaters in the section and/or continuous injection of oxidizing fluid to cause exothermic reactions that heat the formation.

[0998] In some embodiments, hydrocarbons produced through thermal and/or catalytic treatment in section 608A may be used as a diluent and/or a solvent in the section. The produced hydrocarbons may include aromatic hydrocarbons. The aromatic enriched diluent may dilute or solubilize a portion of the heavy hydrocarbons in section 608A and/or other sections in the formation (for example, sections 608B and/or 608C) and form a mixture. The mixture may be produced from the formation (for example, produced from sections 608A and/or 608C). In some embodiments, the mixture is produced from section 608B. In some embodiments, the mixture drains to a bottom portion of the section and solubilizes additional hydrocarbons at the bottom of the section. Solubilized hydrocarbons may be produced or mobilized from the formation. In some embodiments, fluids produced in section 608A (for example, diluent, desirable products, oxidized products, and/or solubilized hydrocarbons) may be pushed towards section 608B as shown by the arrows in FIG. 114 by oxidizing fluid, drive fluid, and/or created drive fluid.

[0999] In some embodiments, the temperatures in section 608A and the generation of drive fluid in section 608A increases the pressure of section 608A so the drive fluid pushes fluids through section 608B into section 608C. Hot fluids flowing from section 608A into section 608B may melt, solubilize, visbreak and/or crack fluids in section 608B sufficiently to allow the fluids to move to section 608C. In

section 608C, the fluids may be upgraded and/or produced through production wells 206.

[1000] In some embodiments, a portion of the catalyst system from section 608A enters section 608B and/or section 608C and contacts fluids in the sections. Contact of the catalyst with formation fluids in 608B and/or section 608C may result in the production of hydrocarbons having a lower API gravity than the mobilized fluids.

[1001] The fluid mixture formed from contact of hydrocarbons, formation fluid and/or mobilized fluids with the catalyst system may be produced from the formation. The liquid hydrocarbon portion of the fluid mixture may have an API gravity between 10° and 25°, between 12° and 23° or between 15° and 20°. In some embodiments, the produced mixture has at most 0.25 grams of aromatics per gram of total hydrocarbons. In some embodiments, the produced mixture includes some of the catalysts and/or used catalysts.

[1002] In some embodiments, contact of the hydrocarbon fluids with the catalyst system produces coke in 608A. Oxidizing fluid may be introduced into section 608A. The oxidizing fluid may react with the coke to generate heat that maintains the average temperature of section 608A in a desired range. For some time intervals, additional oxidizing fluid may be added to section 608A to increase the oxidation reactions to regenerate catalyst in the section. The reaction of the oxidizing fluid with the coke may reduce the amount of coke and heat formation and/or catalyst to temperatures sufficient to remove impurities on the catalyst. Coke, nitrogen containing compounds, sulfur containing compounds, and/or metals such as nickel and/or vanadium may be removed from the catalyst. Removing impurities from the catalyst in situ may enhance catalyst life. After catalyst regeneration, introduction of reaction fluids may be adjusted to allow section 608A to return to an average temperature in the desired temperature range. The average temperature in section 608A may be controlled to be in range from about 250° C. to about 700° C. Hydrocarbons may be introduced in section 608A to continue the cycle. Additional catalyst systems may be introduced into the formation as needed.

[1003] A method for treating a subsurface formation in stages may include using an in situ heat treatment process in combination with injection of an oxidizing fluid and/or drive fluid in one or more portions (sections) of the formation. In some embodiments, hydrocarbons are produced from a first portion and/or a third portion by an in situ heat treatment process. A second portion that separates the first and third portions may be heated with one or more heaters to an average temperature of at least about 100° C. The heat provided to the first portion may be reduced or turned off after a selected time. Oxidizing fluid may be injected in the first portion to oxidize hydrocarbons in the first portion and raise the temperature of the first portion. A drive fluid and/or additional oxidizing fluid may be injected and/or created in the third portion to cause at least some hydrocarbons to move from the third portion through the second portion to the first portion of the hydrocarbon layer. Injection of the oxidizing fluid in the first portion may be reduced or discontinued and additional hydrocarbons and/or syngas may be produced from the first portion of the formation. The additional hydrocarbons and/or syngas may include at least some hydrocarbons from the second and third portions of the formation. Transportation fuel may be produced from the hydrocarbons produced from the first,

second and/or third portions of the formation. In some embodiments, a catalyst system is provided to the first portion and/or third portion.

[1004] In certain embodiments, sections 608A and 608C are heated at or near the same time to similar temperatures (for example, pyrolysis temperatures) with heaters 412. Sections 608A and 608C may be heated to mobilize and/or pyrolyze hydrocarbons in the sections. The mobilized and/or pyrolyzed hydrocarbons may be produced (for example, through one or more production wells 206) from section 608A and/or section 608C. Section 608B may be heated to lower temperatures (for example, mobilization temperatures) by heaters 412. Sections 608D and 608E may not be heated. Little or no production of hydrocarbons to the surface may take place through section 608B, section 608D and/or section 608E. For example, sections 608A and 608C may be heated to average temperatures of at least about 300° C. or at least about 330° C. while section 608B is heated to an average temperature of at least about 100° C., sections 608D and 608E are not heated and no production wells are operated in section 608B, section 608D, and/or section 608E. In some embodiments, heat from section 608A and/or section 608C transfers to sections section 608D and/or section 608E.

[1005] In some embodiments, heavy hydrocarbons in section 608B may be heated to mobilization temperatures and flow into sections 608A and 608C. The mobilized hydrocarbons may be produced from production wells 206 in sections 608A and 608C. After some or most of the fluids have been produced from sections 608A and 608C, production of formation fluids in the sections may be slowed and/or discontinued.

[1006] In certain embodiments, heating and producing hydrocarbons from sections 608A and 608C creates fluid injectivity in the sections. After fluid injectivity has been created in section 608C, an oxidizing fluid may be injected into the section. For example, oxidizing fluid may be injected in section 608C after a majority of the hydrocarbons have been produced from the section. The fluid may be injected through heaters 412, production wells 206, and/or injection wells located in section 608C. In some embodiments, heaters 412 continue to provide heat while the fluid is being injected. In certain embodiments, heaters 412 may be turned down or off before or during fluid injection.

[1007] During injection of oxidant, excess oxidant and/or oxidation products may be removed from section 608C through one or more production wells 206 and/or heater/gas production wells. In some embodiments, after the formation is raised to a desired temperature, a second fluid may be introduced into section 608C. The second fluid may be steam and/or water. Addition of the second fluid may cool the formation. For example, when the second fluid is steam and/or water, the reactions of the second fluid with coke and/or hydrocarbons are endothermic and produce synthesis gas. In some embodiments, oxidizing fluid is added with the second fluid so that some heating of section 608C occurs simultaneous with the endothermic reactions. In some embodiments, section 608C is treated in alternating steps of adding oxidant and second fluid to heat the formation for selected periods of time.

[1008] In certain embodiments, the pressure of the injected fluids and the pressure section 608C are controlled to control the heating in the formation. The pressure in section 608C may be controlled by controlling the production rate of fluids from the section (for example, the production rate of hydro-

carbons, oxidation gases and/or syngas products). Heating in section 608C may be controlled so that there is enough hydrocarbon volume in the section to maintain the oxidation reactions in the formation. Heating and/or pressure in section 608C may also be controlled (for example, by producing a minimal amount of hydrocarbons, oxidation gases and/or syngas products) so that enough pressure is generated to create fractures in sections adjacent to the section (for example, creation of fractures in section 608B). Creation of fractures in adjacent sections may allow fluids from adjacent sections to flow into section 608C and cool the section. Injection of oxidizing fluid may allow portions of the formation below the section heated by heaters to be heated, thus allowing heating of formation fluids in deeper and/or inaccessible portions of the subsurface to be accessed. Section 608C may be cooled from temperatures that promote syngas production to temperatures that promote formation of visbroken and/or upgrade products. Such control of heat and pressure in the section may improve efficiency and quality of products produced from the formation.

[1009] During heating of section 608C or after the section has reached a desired temperature (e.g., temperatures of at least 300° C., at least about 400° C., or at least about 500° C.), an oxidizing fluid and/or a drive fluid may be injected and/or created in section 608A. The drive fluid includes, but is not limited to, steam, water, hydrocarbons, surfactants, polymers, carbon dioxide, air, or mixtures thereof. In some embodiments, the catalyst system described herein is injected in section 608A. In some embodiments, the catalyst system is injected prior to injecting the oxidizing fluid. In some embodiments, production of fluid from section 608A is discontinued prior to injecting fluids in the section. In some embodiments, heater wells in section 608A are converted to injection wells.

[1010] In some embodiments, drive fluids are created in section 608A. Created drive fluids may include air, steam, carbon dioxide, carbon monoxide, hydrogen, methane, pyrolyzed hydrocarbons and/or diluent. In some embodiments, hydrocarbons (for example, hydrocarbons produced from section 608A and/or section 608C, low value hydrocarbons and/or waste hydrocarbon streams) are provided as a portion of the drive fluid. In some embodiments, hydrocarbons are introduced into section 608A prior to injecting an oxidizing fluid and/or the second fluid. Oxidation, catalytic cracking, and/or thermal cracking of introduced hydrocarbon fluids may create the drive fluid and/or a diluent.

[1011] In some embodiments, oxidizing fluid, steam or water are provided as a portion of the drive fluid. The addition of oxidizing fluid, steam, and/or water in the drive fluid may be used to control temperatures in the sections. For example, the addition of steam or water may be cool the section. In some embodiments, water injected as the drive fluid is turned into steam in the formation due to the higher temperatures in the formation. The conversion of water to steam may be used to reduce temperatures or maintain temperatures in the sections between 270° C. and 450° C. Maintaining the temperature between 270° C. and 450° C. may produce higher quality hydrocarbons and/or generate a minimal amount of non-condensable gases.

[1012] Residual hydrocarbons and/or coke in section 608A may be melted, visbroken, upgraded and/or oxidized to produce products that may be pushed towards section 608B as shown by the arrows in FIG. 114. In some embodiments, the temperature in section 608C and the generation of drive fluid

in section 608A may increase the pressure of section 608A so the drive fluid pushes fluids through section 608B into section 608C. Hot fluids flowing from section 608A into section 608B may melt and/or visbreak fluids in section 608B sufficiently to allow the fluids to move to section 608C. In section 608C, the fluids may be upgraded and/or produced through production wells 206.

[1013] In some embodiments, oxidizing fluid injected in section 608A is controlled to raise the average temperature in the section to a desired temperature (for example, at least about 350° C., or at least about 450° C.). Injection of oxidizing fluid and/or drive fluid in section 608A may continue until most or a substantial portion of the fluids from section 608A are moved through section 608B to section 608C. After a period of time, injection of oxidant and/or drive fluid into 608A is slowed and/or discontinued.

[1014] Injection of oxidizing fluid into section 608C may be slowed or stopped during injection and/or creation of drive fluid and/or creation of diluent in section 608A. In some embodiments, injection of oxidizing fluid in section 608C is continued to maintain an average temperature in the section of about 500° C. during injection and/or creation of drive fluid and/or diluent in section 608A. In some embodiments, the catalyst system is injected in section 608C.

[1015] As section 608A and/or section 608C are treated with oxidizing fluid, heaters in sections 608D and 608E may be turned on. In some embodiments, section 608D is heated through conductive heat transfer from section 608C and/or convective heat transfer. Section 608E may be heated with heaters. For example, an average temperature in section 608E may be raised to above 300° C. while an average temperature in section 608D is maintained between 80° C. and 120° C. (for example, at about 100° C.).

[1016] As temperatures in section 608E reach a desired temperature (for example, above 300° C.), production of formation fluids from section 608E through production wells 206 may be started. The temperature may be reached before, during or after oxidizing fluid and/or drive fluid is injected and/or drive fluid and/or diluent is created in section 608A.

[1017] Once the desired temperature in section 608E has been obtained (for example, above 300° C., or above 400° C.), production may be slowed and/or stopped in section 608C and oxidation fluid and/or drive fluid is injected and/or created in section 608C to move fluids from section 608C through cooler section 608D towards section 608E as shown by the arrows in FIG. 115. Injection and/or creation of additional oxidation fluid and/or drive fluid in section 608C may upgrade hydrocarbons from section 608B that are in section 608C and/or may move fluids towards section 608E.

[1018] In some embodiments, heaters in combination with heating produced by oxidizing hydrocarbons in sections 608A, 608C and/or section 608E allows for a reduction in the number of heaters to be used in the sections and/or less capital costs as heaters made of less expensive materials may be used. The heating pattern may be repeated through the formation.

[1019] In some embodiments, fluids in hydrocarbon layer 388 (for example, layers in a tar sands formation) may preferentially move horizontally within the hydrocarbon layer from the point of injection because the layers tend to have a larger horizontal permeability than vertical permeability. The higher horizontal permeability allows the injected fluid to move hydrocarbons between sections preferentially versus fluids draining vertically due to gravity in the formation.

Providing sufficient fluid pressure with the injected fluid may ensure that fluids are moved from section 608A through section 608B into section 608C for upgrading and/or production or from section 608C through section 608D into section 608E for upgrading and/or production. Increased heating in sections 608A, 608C, and 608E may mobilize fluids from sections 608B and 608D into adjacent sections. Increased heating may also mobilize fluids below section 608A through 608E and the fluid may flow from the colder sections into the heated sections for upgrading and/or production due to pressure gradients established by producing fluid from the formation. In some embodiments, one or more production wells are placed in the formation below sections 608A through 608E to facilitate production of additional hydrocarbons.

[1020] In some embodiments, after sections 608A and 608C are heated to desired temperatures, the oxidizing fluid is injected into section 608C to increase the temperature in the section. The fluids in section 608C may move through section 608B into section 608A as indicated by the arrows in FIG. 116. The fluids may be produced from section 608A. Once a majority of the fluids have been produced from section 608A, the treatment process described in FIG. 114 and FIG. 115 may be repeated.

[1021] In some embodiments, treating a formation in stages includes heating a first portion from one or more heaters located in the first portion. Hydrocarbons may be produced from the first portion. Heat provided to the first portion may be reduced or turned off after a selected time. A second portion may be substantially adjacent to the first portion. An oxidizing fluid may be injected in the first portion to cause a temperature of the first portion to increase sufficiently to oxidize hydrocarbons in the first portion and a third portion, the third portion being substantially below the first portion. The second portion may be heated from heat provided from the first portion and/or third portion and/or one or more heaters located in the second portion such that an average temperature in the second portion is at least about 100° C. Hydrocarbons may flow from the second portion into the first portion and/or third portion. Injection of the oxidizing fluid may be reduced or discontinued in the first portion. The temperature of the first portion may cool to below 600° C. to 700° C. and additional hydrocarbons may be produced from the first portion of the formation. The additional hydrocarbons may include oxidized hydrocarbons from the first portion, at least some hydrocarbons from the second portion, at least some hydrocarbons from the third portion of the formation, or mixtures thereof. Transportation fuel may be produced from the hydrocarbons produced from the first, second and/or third portions of the formation.

[1022] In some embodiments, in situ heat treatment followed by oxidation and/or catalyst addition as described for horizontal sections is performed in vertical sections of the formation. Heating a bottom vertical layer followed by oxidation may create microfractures in middle sections thus allowing heavy hydrocarbons to flow from the "cold" middle section to the warmer bottom section. Lighter fluids may flow into the top section and continue to be upgraded and/or produced through production wells. In some embodiments, two vertical sections are treated with heaters followed by oxidizing fluid.

[1023] In some embodiments, heaters in combination with an oxidizing fluid and/or drive fluid are used in various patterns. For example, cylindrical patterns, square patterns, or hexagonal patterns may be used to heat and produce fluids

from a subsurface formation. FIG. 117 and FIG. 118, depict various patterns for treatment of a subsurface formation. FIG. 117 depicts an embodiment of treating a subsurface formation using a cylindrical pattern. FIG. 118 depicts an embodiment of treating multiple sections of a subsurface formation in a rectangular pattern. FIG. 119 is a schematic top view of the pattern depicted in FIG. 118.

[1024] Hydrocarbon layer 388 may be separated into section 608A and section 608B. Section 608A represents a section of the subsurface formation that is to be produced using an in situ heat treatment process. Section 608B represents a section of formation that surrounds section 608A and is not heated during the in situ heat treatment process. In certain embodiments, section 608B has a larger volume than section 608A and/or section 608C. Section 608A may be heated using heaters 412 to mobilize and/or pyrolyze hydrocarbons in the section. The mobilized and/or pyrolyzed hydrocarbons may be produced (for example, through one or more production wells 206) from section 608A. After some or all of the hydrocarbons in section 608A have been produced, an oxidizing fluid may be injected into the section. The fluid may be injected through heaters 412, a production well, and/or an injection well located in section 608A. In some embodiments, at least a portion of heaters 412 are used and/or converted to injection wells. In some embodiments, heaters 412 continue to provide heat while the fluid is being injected. In other embodiments, heaters 412 may be turned down or off before or during fluid injection.

[1025] In some embodiments, providing oxidizing fluid such as air to section 608A causes oxidation of hydrocarbons in the section and in portions of section 608C. In some embodiments, treatment of section 608A with the heaters creates coked hydrocarbons and formation with substantially uniform porosity and/or substantially uniform injectivity so that heating of the section is controllable when oxidizing fluid is introduced to the section. The oxidation of hydrocarbons in section 608A will maintain the average temperature of the section or increase the average temperature of the section to higher temperatures (for example, above 400° C., above 500° C., above 600° C., or higher).

[1026] In some embodiments, an average temperature of section 608C that is located below section 608A increases due to heat generated through oxidation of hydrocarbons and/or coke in section 608A. For example, an average temperature in section 608C may increase from formation temperature to above 500° C. As the average temperature in section 608A and/or section 608C increases through oxidation reactions, the temperature in section 608B increases and fluids may be mobilized towards section 608A as shown by the arrows in FIG. 117 and FIG. 118. In some embodiments, section 608B is heated by heaters to an average temperature of at least about 100° C.

[1027] In section 608A, mobilized hydrocarbons are oxidized and/or pyrolyzed to produce visbroken, oxidized, pyrolyzed products. For example, cold bitumen in section 608B may be heated to mobilization temperature of at least about 100° C. so that it flows into section 608A and/or section 608C. In section 608A and/or section 608C, the bitumen is pyrolyzed to produce formation fluids. Fluids may be produced through production wells 206 and/or heater/gas production wells in section 608A. In some embodiments, no fluids are produced from section 608A during oxidation. Injection of oxidizing fluid may be reduced or discontinued in section 608A once a desired temperature is reached (for example, a

temperature of at least 350° C., at least 300° C., or above 450° C.). Once oxidizing fluid is slowed and/or discontinued in sections 608A, 608C, the sections may cool (e.g. to temperatures below about 700° C., about 600° C., below 500° C. or below 400° C.) and remain at upgrading and/or pyrolysis temperatures for a period of time. Fluids may continue to be upgraded and may be produced from section 608A through production wells.

[1028] In certain embodiments, section 608B and/or section 608D as described in reference to FIGS. 111-119 has a larger volume than section 608A, section 608C, and/or section 608E. Section 608B and/or section 608D may be larger in volume than the other sections so that more hydrocarbons are produced for less energy input into the formation. Because less heat is provided to section 608B and/or section 608D (the section is heated to lower temperatures), having a larger volume in section 608B and/or section 608D reduces the total energy input to the formation per unit volume. The desired volume of section 608B and/or section 608D may depend on factors such as, but not limited to, viscosity, oil saturation, and permeability. In addition, the degree of coking is much less in section 608B and/or section 608D due to the lower temperature so less hydrocarbons are coked in the formation when section 608B and/or section 608D has a larger volume. In some embodiments, the lower degree of heating in section 608B and/or section 608D allows for cheaper capital costs as lower temperature materials (cheaper materials) may be used for heaters used in section 608B and/or section 608D.

[1029] Using the remaining hydrocarbons for heat generation and only using electrical heating for the initial heating stage may improve the overall energy use efficiency of treating the formation. Using electrical heating only in the initial step may decrease the electrical power needs for treating the formation. In addition, forming wells that are used for the combination of production, injection, and heating/gas production may decrease well construction costs. In some embodiments, hot gases produced from the formation are provided to turbines. Providing the hot gases to turbines may recover some energy and improve the overall energy use efficiency of the process used to treat the formation.

[1030] Treating the subsurface formation, as shown by the embodiments of FIGS. 111-117 may utilize carbon remaining after production of mobilized, visbroken, and/or pyrolyzed hydrocarbons for heat generation in the formation. In some embodiment, treating hydrocarbons in the subsurface formation, as shown in by the embodiments in FIGS. 111-117 creates products having economic value from hydrocarbons having low economic value and/or from waste hydrocarbon streams from surface facilities.

[1031] Treating hydrocarbon containing formations in order to convert, upgrade, and/or extract the hydrocarbons is an expensive and time consuming process. Any process and/or system which might increase the efficiency of the treatment of the formation is highly desirable. Increasing the efficiency of the treatment of the formation may include optimizing heat source locations and the spacing between the heat sources in a pattern of heat sources. Increasing the efficiency of the treatment of the formation may include optimizing the heating schedule of the formation. Repositioning the location of a producer wells (e.g., vertically within the formation) may increase the efficiency of the treatment of the formation. Adjusting the initial bottom-hole pressure of one or more producer well in the formation may increase the efficiency of the formation treatment process. Adjusting the blowdown

time of one or more producer wells may increase the efficiency of the formation treatment process. Optimizing one or more of the mentioned variables alone, or in combination, may increase the efficiency of the formation treatment process resulting in reduced costs and/or increased production. Even a relatively small increase of efficiency may result in billions of dollars of additional revenue due to the scale of such treatment processes in the form of reduced operating costs, increased quality of the hydrocarbon product produced, and/or increased quantity of the hydrocarbon product produced from the formation.

[1032] Many different types of wells or wellbores may be used to treat the hydrocarbon containing formation using the in situ heat treatment process. In some embodiments, vertical and/or substantially vertical wells are used to treat the formation. In some embodiments, horizontal (such as J-shaped wells and/or L-shaped wells), and/or u-shaped wells are used to treat the formation. In some embodiments, combinations of horizontal wells, vertical wells, and/or other combinations are used to treat the formation. In certain embodiments, wells extend through the overburden of the formation to a hydrocarbon containing layer of the formation. Heat in the wells may be lost to the overburden. In certain embodiments, surface and/or overburden infrastructures used to support heaters and/or production equipment in horizontal wellbores and/or u-shaped wellbores are large in size and/or numerous.

[1033] In certain embodiments, heaters, heater power sources, production equipment, supply lines, and/or other heater or production support equipment are positioned in substantially horizontal and/or inclined tunnels. Positioning these structures in tunnels may allow smaller sized heaters and/or other equipment to be used to treat the formation. Positioning these structures in tunnels may also reduce energy costs for treating the formation, reduce emissions from the treatment process, facilitate heating system installation, and/or reduce heat loss to the overburden, as compared to conventional hydrocarbon recovery processes that utilize surface based equipment. U.S. Published Patent Application Nos. 2007-0044957 to Watson et al.; 2008-0017416 to Watson et al.; and 2008-0078552 to Donnelly et al., all of which are incorporated herein by reference, describe methods of drilling from a shaft for underground recovery of hydrocarbons and methods of underground recovery of hydrocarbons.

[1034] In some embodiments, increasing the efficiency of the treatment of the formation may include optimizing heat source locations and the spacing between the heat sources in a pattern of heat sources. In certain embodiments, heat sources (for example, heaters) have uneven or irregular spacing in a heater pattern. For example, the space between heat sources in the heater pattern varies or the heat sources are not evenly distributed in the heater pattern. In certain embodiments, the space between heat sources in the heater pattern decreases as the distance from the production well at the center of the pattern increases. Thus, the density of heat sources (number of heat sources per square area) increases as the heat sources get more distant from the production well.

[1035] In some embodiments, heat sources are evenly spaced in the heater pattern but have varying heat outputs such that the heat sources provide an uneven or varying heat distribution in the heater pattern. Varying the heat output of the heat sources may be used to, for example, effectively mimic having heat sources with varying spacing in the heater pattern. For example, heat sources closer to the production well at the center of the heater pattern may provide lower heat

outputs than heat sources at further distances from the production well. The heater outputs may be varied such that the heater outputs gradually increase as the heat sources increase in distance from the production well.

[1036] Heat sources may be positioned in an irregular pattern in a horizontally oriented heating zone of the formation in relation to, for example, a producer well. Heat sources may be positioned in an irregular pattern in a vertically oriented heating zone of the formation in relation to, for example, a producer well. Irregular patterns may have advantages over previous equivalently spaced patterns relative to a producer well. For example, irregular patterns of heat sources may create channels within the formation to assist in directing hydrocarbons through the channels more efficiently to producer wells. In some embodiments, patterns of heat sources may be based on the distribution and/or type of hydrocarbons in the formation. The portion of the formation may be divided into different heating zones. Different zones within the same formation may have different patterns of heaters within each zone, for example, depending upon the particular type of hydrocarbon within the particular heating zone.

[1037] Using irregular patterns for positioning heat sources in the formation may reduce the number of heat sources needed in the formation. The installation and maintenance of heat sources in a formation accounts for a significant percentage of the operating costs associated with the treatment of the formation. In some instances, installation and maintenance of heat sources in the formation may account for as much as 60% or more of the operating costs of treating the formation. Reducing the number of heaters used to treat the formation has significant economic benefits. Reducing the time that heaters are used to heat the portion of the formation will reduce costs associated with treating the portion.

[1038] In certain embodiments, the uneven or irregular spacing of heat sources is based on regular geometric patterns. For example, the irregular spacing of heat sources may be based on a hexagonal, triangular, square, octagonal, other geometric combinations, and/or combinations thereof. In some embodiments, heat sources are placed at irregular intervals along one or more of the geometric patterns to provide the irregular spacing. In some embodiments, the heat sources are placed in an irregular geometric pattern. In some embodiments, the geometric pattern has irregular spacing between rows in the pattern to provide the irregular spacing of heat sources.

[1039] Increasing the efficiency of the treatment of the formation may include optimizing the heating schedule of the formation. As previously mentioned, the installation and maintenance of heat sources in a formation accounts for a significant percentage of the operating costs associated with the treatment of the formation. Maintenance may include the energy required by the heat sources to heat the formation. Previously, treatment of a formation included heating the formation with heat sources, the majority of which were typically turned on at the same time or at least within a relatively short time frame. In some embodiments, implementing a heating schedule may include heating the portion of the formation in phases. Different horizontal zones within the portion of the formation may be controlled independently and may be heated at different times during the treatment process. Different vertical zones within the portion of the formation may be controlled independently and may be heated at different times during the treatment process. Heat

sources within different zones within a portion may start initiate their heating cycle at different times.

[1040] Heating in a first zone of the formation may be initiated using a first set of heat sources positioned in the first zone. Heating in a second zone of the formation may be initiated using a second set of heat sources positioned in the second zone. Heating may be initiated in the second zone after the first set of heat sources in the first zone have commenced heating the first zone. Heating in the first zone may continue after heating in the second zone initiates. In some embodiments, heating in the first zone may discontinue when, or at some point after, heating in the second zone initiates. When referring to the first zone or the second zone herein, this nomenclature should not be seen as limiting and these terms do not refer to the physical relation of the different zones to each other within the portion of the formation. In some embodiments, the portion of the formation may include two or more heating zones. For example, the portion of the formation may include 3, 4, 5, or 6 heating zones per portion of the formation. In certain embodiments, the portion of the formation includes 4 heating zones per portion of the formation. The heating zone may include one or more rows of heat sources. In some embodiments, heat produced by heat sources within different heating zones overlaps providing a cumulative heating effect upon the portion of the formation where the overlap occurs. Different portions of the formation may have different heat source patterns and/or numbers of heat sources within each zone.

[1041] In some embodiments, heater sequencing is used to increase efficiency by heating a bottom portion of the formation before heating an upper portion of the formation. Heating the bottom portion of the formation first may allow some in situ conversion of any hydrocarbons (for example, bitumen) in the bottom portion. As hydrocarbons products are produced from the bottom portion using production wells positioned in the formation, hydrocarbons from the upper portion of the formation may be conveyed towards the bottom portion. In some embodiments, hydrocarbons from the upper portion that have been conveyed to the lower portion have not been heated by heat sources positioned in the upper portion.

[1042] In some embodiments, the lower portion of the formation includes approximately the lower third of the formation (not including the overburden). The upper portion may include approximately the upper two thirds of the formation (not including the overburden). In certain embodiments, about 20% or more heat flux per volume is injected into the lower portion than the upper portion over the first five years of treatment of the formation. For the entire formation, such injection may equate into about 15% less heat flux per volume for the first five years as compared to turning on all of the heaters at the same time using heaters with consistent heater spacing.

[1043] Greater heat flux per volume may be provided to one portion (for example, the lower portion) relative to another portion (for example, the upper portion) of the formation using several different methods. In some embodiments, the lower portion includes more heat sources than the upper portion. In some embodiments, heat sources in the lower portion provide heat for a longer period of time than heat sources in the upper portion of the formation. In some embodiments, heat sources in the lower portion provide more energy per heat source than heat sources in the upper portion. Any combination of the mentioned methods may be used to

ensure greater heat flux to one portion of the formation relative to another portion of the formation.

[1044] Producing hydrocarbons from the lower portion first may create space in the lower formation for hydrocarbons from the upper portion to be conveyed by gravity to the lower portion. Not heating hydrocarbons in the upper portion of the formation may reduce over cracking or over pyrolyzing of these hydrocarbons, which may result in a better quality of produced hydrocarbons for the formation. Using such a strategy may result in a lower gas to oil ratio. In some embodiments, a greater reduction in the percentage of gas produced relative to the increase in the percentage of oil produced may result, but the overall total market value of the products may be greater.

[1045] In certain embodiments, hydrocarbons in the lower portion are pyrolyzed and produced first, and any pyrolyzation products (for example, gas products) resulting from the pyrolyzation process in the lower portion may move out of the lower portion into the upper portion. Products moving from the lower portion to the upper portion of the formation may result in pressure increasing in the upper portion. Pressure increases in the upper portion may result in increased permeability in the upper portion resulting in easier movement of hydrocarbons in the upper portion to the lower portion for pyrolyzation and/or production. Pyrolyzation products moving to the upper portion may heat the upper portion of the formation.

[1046] In certain embodiments, production wells are positioned in and/or substantially adjacent a lower portion of the formation. Positioning production wells in and/or substantially adjacent a lower portion of the formation facilitates production of hydrocarbons from the lower portion of the formation. Heat sources adjacent to the production well may be horizontally and/or vertically offset from the production well. In some embodiments, a horizontal row of heat sources is positioned at a depth equivalent to the depth of the production well. A row of multiple heat sources may also be positioned at a greater or lesser depth than the depth of the production well. Such an arrangement of heat sources relative to the production well may create channels within the formation for movement of mobilized and/or pyrolyzed hydrocarbons toward the production well.

[1047] FIG. 120 depicts a cross-sectional representation of substantially horizontal heaters 412 positioned in a pattern with consistent spacing in a hydrocarbon layer in the Grosmont formation. Horizontal heaters 412 are positioned in a consistently spaced pattern around and in relation to producer wells 206 in hydrocarbon layer 388 beneath overburden 400. Patterns with consistent spacing, typically horizontally and vertically, as depicted in FIG. 120 have been discussed previously. FIG. 121 depicts a cross-sectional representation of substantially horizontal heaters 412 positioned in a pattern with irregular spacing in hydrocarbon layer 388 in the Grosmont formation. Horizontal heaters 412 are positioned in an irregularly spaced pattern around and in relation to producer wells 206 in hydrocarbon layer 388 beneath overburden 400. In the embodiment depicted in FIG. 120, there are 16 horizontal heaters 412 per producer well 206. The pattern depicted in FIG. 121 includes four rows of heaters in four heating zones 628A-D. In the embodiment depicted in FIG. 121, vertical spacing between the different rows of heaters in heating zones 628A-D is irregular. There may be at least some to significant overlap of the heat between the rows of heaters. For example, heaters 412 in zones 628C-D may both heat the

area of the formation positioned substantially between the two rows of heaters. In the embodiment depicted in FIG. 121, there are 18 horizontal heaters 412 per producer well 206.

[1048] Heaters 412 in the FIG. 120 embodiment may initiate heating the formation substantially within the same time frame. Heaters 412 in the FIG. 121 embodiment may employ a phased heating process for heating the formation. Heaters 412 in zones 628C-D may initiate first, heating the formation at the same time. Heaters 412 in zone 628B may initiate at a later date (for example, ~104 days after the heaters in zones 628C-D), and finally followed by heaters 412 in zone 628A (for example, ~593 days after the heaters in zones 628C-D).

[1049] FIG. 122 depicts a graphical representation of a comparison of the temperature and the pressure over time for two different portions of the formation using the different heating patterns. Curve 630 depicts the average temperature and curve 632 the average pressure during the treatment process using the consistently spaced heater pattern depicted in FIG. 120. Curve 634 depicts the average temperature and curve 636 the average pressure during the treatment process using the optimized heater pattern depicted in FIG. 121. FIG. 122 shows that average temperature and pressure are lower for the portion of the formation using the optimized heater pattern. The lower average temperature and pressure for the portion of the formation using the optimized heater pattern may explain the increased quality of oil produced by this portion.

[1050] FIG. 123 depicts a graphical representation of a comparison of the average temperature over time for different treatment areas for two different portions of the formation using the different heating patterns. Curves 638, 642, and 646 show the average temperature over time for the Upper Grosmont 3, the Upper Ireton, and Nisku areas, respectively, of the portion of the formation during the treatment process using the consistently spaced heater pattern depicted in FIG. 120. Curves 640, 644, and 648 show the average temperature over time for the Upper Grosmont 3, the Upper Ireton, and Nisku areas, respectively, of the portion of the formation during the treatment process using the optimized heater pattern depicted in FIG. 121. A lower average temperature is seen in FIG. 123 for the optimized heater pattern for the deeper Upper Grosmont 3 and Upper Ireton; however, the Nisku which is heated directly in the optimized heater pattern has a higher average temperature.

[1051] In the embodiment depicted in FIG. 120, the bottom-hole pressure was overall kept at a relatively high pressure, which varied greatly over the course of the treatment process. Additionally, the blowdown time was at greater than 2000 days and the upper layer of the hydrocarbon containing portion below the overburden was not heated for the embodiment depicted in FIG. 120. However, for the embodiment depicted in FIG. 121, the bottom-hole pressure was overall kept at a relatively low pressure which varied little for long periods of time over the course of the treatment process. The blowdown time was at ~400 days and the upper layer of the hydrocarbon containing portion below the overburden was heated (see the heaters in zone 628A) for the embodiment depicted in FIG. 121. In some embodiments, the pressure in the formation is increased to between about 300 psi (about 2070 kPa) and about 500 psi (3450 kPa) for a period of time. The period of time may be 200 days to 600 days, 300 days to 500 days, or 350 days to 450 days. After the period of time has expired, the pressure in the formation may be decreased to between about 75 psi (about 515 kPa) and about 150 psi

(about 1030 kPa). FIG. 124 depicts a graphical representation of the bottom-hole pressures over time for two producer wells (curves 650 and 652) associated with the heater pattern in FIG. 120 and for two producer wells (curves 654 and 656) associated with the heater pattern in FIG. 121. Some of the differences between the two treatment processes are summarized in TABLE 2.

TABLE 2

	Heater Pattern in FIG. 120	Heater Pattern in FIG. 121
Number of Heaters/Producer	16	18
Heating Schedule	Constant heating of entire portion of formation	Phased heating
Blowdown Time	Late (>2000 days)	
Bottom-Hole Pressure	High and variable	Low and steady
Heater Spacing	Consistent spacing	Variable horizontal and vertical spacing
Upper Area of Treated Portion	No direct heat	Directly heated with installed heaters

[1052] The differences between the heating process depicted in FIG. 120 and in FIG. 121 resulted in significant differences in the results of the treatment processes. In the optimized heating treatment process, depicted in FIG. 121, a preferably much lower gas-to-oil ratio (GOR) resulted relative to the treatment process depicted in FIG. 120. Heating in zone 628A increased liquid hydrocarbon production by ~38% in the zone relative to a similar area in the treatment process depicted in FIG. 120. In addition, overall oil production was increased and the bitumen fraction decreased for the optimized heating treatment process FIG. 121 relative to the FIG. 120 treatment process.

[1053] FIG. 125 depicts a graphical representation of a comparison of the cumulative oil and gas products extracted over time from two different portions of the formation using the different heating patterns. Curves 658 and 662 show the cumulative oil and gas products, respectively, extracted over time for the portion of the formation using the consistently spaced heater pattern depicted in FIG. 120. Curves 660 and 664 show the cumulative oil and gas products, respectively, extracted over time for the portion of the formation using the optimized heater pattern depicted in FIG. 121. The optimized heater pattern produced significantly more oil, but less gas, due to the lower operating temperatures and less pyrolyzation of the hydrocarbons. Some of the differences between the results of using the two treatment processes are summarized in TABLE 3.

TABLE 3

	Heater Pattern in FIG. 120	Heater Pattern in FIG. 121	Percent Change
Cumulative Oil (bbl)	58,891	78,746	33.7%
Cumulative TB (bbl)	16,802	17,771	5.8%
Cumulative HO (bbl)	22,051	32,577	47.7%
Cumulative LO (bbl)	19,263	27,879	44.7%
Cumulative Gas (MMscf)	104.0	69.5	-33.2%
Cumulative Heat (MMBTU)	80,715	77,577	-3.9%
Heat Efficiency (bbl/MMBTU)	0.73	1.02	39.7%
API	22.9	24.6	7.4%
NPV (\$MM)	1.54	2.17	40.9%

TABLE 3-continued

	Heater Pattern in FIG. 120	Heater Pattern in FIG. 121	Percent Change
NPV/Capital Expenses	4.47	5.64	26.2%
NPV/(Capital Expenses + Operating Expenses)	1.18	1.64	39.0%

[1054] The increases in quantity and quality in liquid hydrocarbons for the optimized heating treatment process resulted in an increase of ~\$1 billion in net present value (NPV). Net present value may be roughly calculated using EQN. 10:

$$\text{NPV} = \Sigma \{ \text{Annually Discounted}(\text{oil revenue} - \text{operating expenses} - \text{energy expenses}) - \text{wellbore capital expenses} \} \quad \text{EQN. (10)}$$

[1055] FIG. 126 depicts a cross-sectional representation of another embodiment of substantially horizontal heaters 412 positioned in a pattern with irregular spacing in hydrocarbon layer 388 in the Grosmont formation. Horizontal heaters 412 are positioned in an irregularly spaced pattern around and in relation to producer wells 206 beneath overburden 400. The pattern depicted in FIG. 126 includes five rows of heaters in five heating zones 628A-E. In the embodiment depicted in FIG. 126, vertical spacing between the different rows of heaters in heating zones 628A-E is irregular. There may be at least some to significant overlap of the heat between the rows of heaters. For example, heaters 412 in zones 628C-E may both heat the area of the formation positioned substantially between the three rows of heaters. In the embodiment depicted in FIG. 126, there are 18 horizontal heaters 412 per producer well 206 as in the irregularly spaced four row heater pattern depicted in FIG. 121.

[1056] Heaters 412 in the FIG. 126 embodiment may employ a phased heating process for heating the formation similar to the embodiment depicted in FIG. 121. Heaters 412 in zone 628E may initiate first. Heaters 412 in zone 628D may initiate at a later date (for example, ~5 days after the heaters in zone 628E), followed by heaters 412 in zone 628C (for example, ~57 days after the heaters in zone 628E). Heaters 412 in zone 628B may initiate at a later date (for example, ~391 days after the heaters in zone 628E), finally followed by heaters 412 in zone 628A (for example, ~547 days after the heaters in zone 628E).

[1057] FIG. 127 depicts a cross-sectional representation of yet another embodiment substantially horizontal heaters 412 positioned in a pattern with irregular spacing in hydrocarbon layer 388 in an hydrocarbon layer. In an embodiment, the hydrocarbon layer is a portion of the Grosmont formation. The pattern depicted in FIG. 127 includes four rows of heaters in four heating zones 628A-D. In the embodiment depicted in FIG. 127, vertical spacing between the different rows of heaters in heating zones 628A-D is irregular. In the embodiment depicted in FIG. 127, there are 17 horizontal heaters 412 per producer well 206.

[1058] Heaters 412 in the FIG. 127 embodiment may employ a phased heating process for heating the formation similar to the embodiment depicted in FIG. 121. Heaters 412 in zones 628C-D may initiate first. Heaters 412 in zone 628B may initiate at a later date (for example, ~17 days after the heaters in zones 628C-D), followed by heaters 412 in zone 628A (for example, ~411 days after the heaters in zones 628C-D).

[1059] FIG. 128 depicts a cross-sectional representation of another embodiment of substantially horizontal heaters 412 positioned in a pattern with irregular spacing in hydrocarbon layer 388 in the Grosmont formation. The pattern depicted in FIG. 128 includes four rows of heaters in four heating zones 628A-D. In the embodiment depicted in FIG. 128, vertical spacing between the different rows of heaters in heating zones 628A-D is irregular. In the embodiment depicted in FIG. 128, there are 15 horizontal heaters 412 per producer well 206.

[1060] Heaters 412 in the FIG. 128 embodiment may employ a phased heating process for heating the formation, similar to the embodiment depicted in FIG. 121. Heaters 412 in zones 628C-D may initiate first. Heaters 412 in zone 628B may initiate at a later date (for example, ~46 days after the heaters in zones 628C-D), followed by heaters 412 in zone 628A (for example, ~291 days after the heaters in zones 628C-D). A comparison of some of the results of the different optimized heating patterns are summarized in TABLE 4. TABLE 4 shows that different patterns of heaters have real impact on the overall efficiency and profitability of the treatment process for subsurface hydrocarbon containing formations. As shown in TABLE 4, using fewer heaters does not necessarily lead to the most desirable result (for example, higher NPV values). In certain embodiments, the most efficient heater pattern for certain formations appear to be the heater pattern depicted in FIG. 121.

TABLE 4

	Heater Pattern in FIG. 121	Heater Pattern in FIG. 126	Heater Pattern in FIG. 127	Heater Pattern in FIG. 128
No. of Heaters/Producer	18	18	17	15
Capital Expenses	384,000	384,000	364,000	324,000
NPV (\$MM)	2.17	1.98	1.90	1.68
NPV/Capital Expenses	5.64	5.15	5.30	5.18
IRR	0.67	0.60	0.63	0.67
Max. Pressure	471.3	608.69	686.3	572.2
Cum. Oil (bbl)	78,745.9	71,107.9	67,551.48	60,132.5
API	24.6	27.94	23.16	21.6
NPV/(Capital Expenses + Operating Expenses)	1.64	1.50	1.54	1.50

[1061] FIG. 129 depicts a cross-sectional representation of another embodiment of substantially horizontal heaters 412 positioned in a pattern with consistent spacing in hydrocarbon layer 388 (similar to the heater pattern in 120) in the Peace River formation. In the embodiment depicted in FIG. 129, there are 9 horizontal heaters 412 per producer well 206. FIG. 130 depicts a cross-sectional representation of an embodiment of substantially horizontal heaters 412 positioned in a pattern with irregular spacing in hydrocarbon layer 388, with three rows of heaters in three heating zones 628A-C. In the embodiment depicted in FIG. 130, vertical spacing between the different rows of heaters in heating zones 628A-C is irregular. In the embodiment depicted in FIG. 130, there are 13 horizontal heaters 412 per producer well 206.

[1062] Heaters 412 in the FIG. 130 embodiment may employ a phased heating process for heating the formation similar to the embodiment depicted in FIG. 121 in the Peace River formation. Heaters 412 in zone 628C may initiate first. Heaters 412 in zone 628A may initiate at a later date (for example, ~53 days after the heaters in zone 628C), followed by heaters 412 in zone 628B (for example, ~93 days after the heaters in zone 628C). The optimized heating pattern depicted in FIG. 130 (NPV was 5.57) demonstrated greater efficiency than the heating pattern depicted in FIG. 129 (NPV was 1.05).

[1063] In some embodiments, when optimizing the heating of the portion of the formation, certain limiting variables are taken into consideration. The pressure in the upper area of the portion of the formation may be limited. Imposing limits on the pressure in the upper portion of the formation may inhibit the overburden from pyrolyzation and allowing products from the treatment process to escape in an uncontrolled manner. Pressure in the upper area of the portion limited to less than or equal to about 1500 psi (about 10 MPa), about 1250 psi (about 8.6 MPa), about 1000 psi (about 6.9 MPa), about 750 psi (about 5.2 MPa), or about 500 psi (about 3.4 MPa). In some embodiments, pressure in the upper area of the portion of the formation may be maintained at about 750 psi (about 5.2 MPa) or less.

[1064] In some embodiments, bottom-hole pressure may need to be maintained greater than or equal to a particular pressure. Bottom-hole pressure, in some examples, may need to be maintained during production at or above about 250 psi (about 1.7 MPa), about 170 psi (about 1.2 MPa), about 115 psi (about 800 kPa), or about 70 psi (about 480 kPa). In some embodiments, a desired bottom-hole pressure may be maintained at or above about 115 psi (about 800 kPa). The minimum bottom-hole pressure required may be dependent on a number of factors, for example, type of formation or the type of hydrocarbons contained in the formation.

[1065] A downhole heater assembly may include 5, 10, 20, 40, or more heaters coupled together. For example, a heater assembly may include between 10 and 40 heaters. Heaters in a downhole heater assembly may be coupled in series. In some embodiments, heaters in a heater assembly may be spaced from about 8 meters (about 25 feet) to about 60 meters (about 195 feet) apart. For example, heaters in a heater assembly may be spaced about 15 meters (about 50 feet) apart. Spacing between heaters in a heater assembly may be a function of heat transfer from the heaters to the formation. Spacing between heaters may be chosen to limit temperature variation along a length of a heater assembly to acceptable limits. Heaters in a heater assembly may include, but are not limited to, electrical heaters, flameless distributed combustors, natu-

ral distributed combustors, and/or oxidizers. In some embodiments, heaters in a downhole heater assembly may include only oxidizers.

[1066] Fuel may be supplied to oxidizers a fuel conduit. In some embodiments, the fuel for the oxidizers includes synthesis gas, non-condensable gases produced from treatment area of in situ heat treatment processes, air, enriched air, or mixtures thereof. In some embodiments, the fuel includes synthesis gas (for example, a mixture that includes hydrogen and carbon monoxide) that was produced using an in situ heat treatment process. In certain embodiments, the fuel may include natural gas mixed with heavier components such as ethane, propane, butane, or carbon monoxide. In some embodiments, the fuel and/or synthesis gas may include non-combustible gases such as nitrogen. In some embodiments, the fuel contains products from a coal or heavy oil gasification process. The coal or heavy oil gasification process may be an in situ process or an ex situ process. After initiation of combustion of fuel and oxidant mixture in oxidizers, composition of the fuel may be varied to enhance operational stability of the oxidizers.

[1067] The non-condensable gases may include combustible gases (for example, hydrogen, hydrogen sulfide, methane and other hydrocarbon gases) and noncombustible gases (for example, carbon dioxide). The presence of noncombustible gases may inhibit coking of the fuel and/or may reduce the flame zone temperature of oxidizers when the fuel is used as fuel for oxidizers of downhole oxidizer assemblies. The reduced flame zone temperature may inhibit formation of NO_x compounds and/or other undesired combustion products by the oxidizers. Other components such as water may be included in the fuel supplied to the burners. Combustion of in situ heat treatment process gas may reduce and/or eliminate the need for gas treatment facilities and/or the need to treat the non-condensable portion of formation fluid produced using the in situ heat treatment process to obtain pipeline gas and/or other gas products. Combustion of in situ heat treatment process gas in burners may create concentrated carbon dioxide and/or SO_x effluents that may be used in other processes, sequestered and/or treated to remove undesired components.

[1068] In certain embodiments, fuel used to initiate combustion may be enriched to decrease the temperature required for ignition or otherwise facilitate startup of oxidizers. In some embodiments, hydrogen or other hydrogen rich fluids may be used to enrich fuel initially supplied to the oxidizers. After ignition of the oxidizers, enrichment of the fuel may be stopped. In some embodiments, a portion or portions of a fuel conduit may include a catalytic surface (for example, a catalytic outer surface) to decrease an ignition temperature of fuel.

[1069] In some embodiments, oxygen is produced through the decomposition of water. For example, electrolysis of water produces oxygen and hydrogen. Using water as a source of oxygen provides a source of oxidant with minimal or no carbon dioxide emissions. The produced hydrogen may be used as a hydrogenation fluid for treating hydrocarbon fluids in situ or ex situ, a fuel source and/or for other purposes. FIG. 131 depicts a schematic representation of an embodiment of a system for producing oxygen using electrolysis of water for use in an oxidizing fluid provided to burners that heat treatment area 666. Water stream 668 enters electrolysis unit 670. In electrolysis unit 670, current is applied to water stream 668 and produces oxygen stream 672 and hydrogen stream 674. In some embodiments, electrolysis of water

stream 668 is performed at temperatures ranging from about 600° C. to about 1000° C., from about 700° C. to about 950° C., or from 800° C. to about 900° C. In some embodiments, electrolysis unit 670 is powered by nuclear energy and/or a solid oxide fuel cell and/or a molten salt fuel cell. The use of nuclear energy and/or a solid oxide fuel cell and/or a molten salt fuel cell provides a heat source with minimal and/or no carbon dioxide emissions. High temperature electrolysis may generate hydrogen and oxygen more efficiently than conventional electrolysis because energy losses resulting from the conversion of heat to electricity and electricity to heat are avoided by directly utilizing the heat produced from the nuclear reactions without producing electricity. Oxygen stream 672 mixes with mixed oxidizing fluid 676 and/or is mixed with oxidizing fluid 678. A portion or all of hydrogen stream 674 may be recycled to electrolysis unit 670 and used as an energy source. A portion or all of hydrogen stream 674 may be used for other purposes such as, but not limited to, a fuel for burners and/or a hydrogen source for in situ or ex situ hydrogenation of hydrocarbons.

[1070] Exhaust gas 680 from burners used to heat treatment area 666 may be directed to exhaust treatment unit 682. Exhaust gas 680 may include, but is not limited to, carbon dioxide and/or SO_x. In exhaust separation unit 682, carbon dioxide stream 684 is separated from SO_x stream 686. Separated carbon dioxide stream 684 may be mixed with diluent fluid 688, may be used as a carrier fluid for oxidizing fluid 678, may be used as a drive fluid for producing hydrocarbons, and/or may be sequestered. SO_x stream 686 may be treated using known SO_x treatment methods (for example, sent to a Claus plant). Formation fluid 212' produced from heat treatment area 666 may be mixed with formation fluid 212 from other treatment areas and/or formation fluid 212' may enter separation unit 214. Separation unit 214 may separate the formation fluid into in situ heat treatment process liquid stream 216, in situ heat treatment process gas 218, and aqueous stream 220. Gas separation unit 222 may remove one or more components from in situ heat treatment process gas 218 to produce fuel 690 and one or more other streams 692. Fuel 690 may include, but is not limited to, hydrogen, sulfur compounds, hydrocarbons having a carbon number of at most 5, carbon oxides, nitrogen compounds, or mixtures thereof. In some embodiments, gas separation unit 222 uses chemical and/or physical treatment systems to remove or reduce the amount of carbon dioxide in fuel 690. Fuel 690 may enter fuel conduit 520 that provides fuel to oxidizers of oxidizer assemblies that heat treatment area 666.

[1071] In some embodiments, electrolysis unit 670 is powered by nuclear energy. Nuclear energy may be provided by a number of different types of available nuclear reactors and nuclear reactors currently under development (for example, generation IV reactors). In some embodiments, nuclear reactors may include a self-regulating nuclear reactor. Self-regulating nuclear reactors may include a fissile metal hydride which functions as both fuel for the nuclear reaction as well as a moderator for the nuclear reaction. The nuclear reaction may be moderated by the temperature driven mobility of the hydrogen isotope contained in the hydride. Self-regulating nuclear reactors may produce thermal power on the order of tens of megawatts per unit. Self-regulating nuclear reactors may operate at a maximum fuel temperature ranging from about 400° C. to about 900° C., from about 450° C. to about 800° C., and from about 500° C. to about 600° C. Self-regulating nuclear reactors have several advantages includ-

ing, but not limited to, a compact/modular design, ease of transport, and a simple cost effective design.

[1072] In some embodiments, nuclear reactors may include one or more very high temperature reactors (VHTRs). VHTRs may use helium as a coolant to drive a gas turbine for treating hydrocarbon fluids in situ, powering electrolysis unit 670 and/or for other purposes. VHTRs may produce heat for electrolysis units up to about 950° C. or more. In some embodiments, nuclear reactors may include a sodium-cooled fast reactor (SFR). SFRs may be designed on a smaller scale (for example, 50 MWe), and therefore are more cost effective to manufacture on site for treating hydrocarbon fluids in situ, powering electrolysis units and/or for other purposes. SFRs may be of a modular design and potentially portable. SFRs may produce heat for electrolysis units ranging from about 500° C. to about 600° C., from about 525° C. to about 575° C., or from 540° C. to about 560° C.

[1073] In some embodiments, pebble bed reactors may be employed to provide heat for electrolysis. Pebble bed reactors may produce up to about 165 MWe. Pebble bed reactors may produce heat for electrolysis units ranging from about 500° C. to about 1100° C., from about 800° C. to about 1000° C., or from about 900° C. to about 950° C. In some embodiments, nuclear reactors may include supercritical-water-cooled reactors (SCWRs) based at least in part on previous light water reactors (LWR) and supercritical fossil-fired boilers. In some embodiments, SCWRs may be employed to provide heat for electrolysis. SCWRs may produce heat for electrolysis units ranging from about 400° C. to about 650° C., from about 450° C. to about 550° C., or from about 500° C. to about 550° C.

[1074] In some embodiments, nuclear reactors may include lead-cooled fast reactors (LFRs). In some embodiments, LFRs may be employed to provide heat for electrolysis. LFRs may be manufactured in a range of sizes, from modular systems to several hundred megawatt or more sized systems. LFRs may produce heat for electrolysis units ranging from about 400° C. to about 900° C., from about 500° C. to about 850° C., or from about 550° C. to about 800° C.

[1075] In some embodiments, nuclear reactors may include molten salt reactors (MSRs). In some embodiments, MSRs may be employed to provide heat for electrolysis. MSRs may include fissile, fertile, and fission isotopes dissolved in a molten fluoride salt with a boiling point of about 1,400° C. which function as both the reactor fuel and the coolant. MSRs may produce heat for electrolysis units ranging from about 400° C. to about 900° C., from about 500° C. to about 850° C., or from about 600° C. to about 800° C.

[1076] In some embodiments, pulverized coal is the fuel used to heat the subsurface formation. The pulverized coal may be carried into the wellbores with a non-oxidizing fluid (for example, carbon dioxide and/or nitrogen). An oxidant may be mixed with the pulverized coal at several locations in the wellbore. The oxidant may be air, oxygen enriched air and/or other types of oxidizing fluids. Igniters located at or near the mixing locations initiate oxidation of the coal and oxidant. The igniters may be catalytic igniters, glow plugs, spark plugs, and/or electrical heaters (for example, an insulated conductor temperature limited heater with heating sections located at mixing locations of pulverized coal and oxidant) that are able to initiate oxidation of the oxidant with the pulverized coal.

[1077] The particles of the pulverized coal may be small enough to pass through flow orifices and achieve rapid combustion in the oxidant. The pulverized coal may have a par-

ticle size distribution from about 1 micron to about 300 microns, from about 5 microns to about 150 microns, or from about 10 microns to about 100 microns. Other pulverized coal particle size distributions may also be used. At 600° C., the time to burn the volatiles in pulverized coal with a particle size distribution from about 10 microns to about 100 microns may be about one second.

[1078] In certain embodiments, a heater is located in a u-shaped wellbore or an L-shaped wellbore. The heater may include a heating section that is moved during treatment of the formation. Moving the heating section during treatment of the formation allows the heating section to be used over a wide area of the formation. Using the movable heating section may allow the heating section (and/or heater) to be significantly shorter in length than the length of the wellbore. The shorter heating section may reduce equipment costs and/or operating costs of the heater as compared to a longer heating section (for example, a heating section that has a length nearly as long as the length of the wellbore).

[1079] FIG. 132 depicts an embodiment of heater 412 with heating section 694 located in a u-shaped wellbore. Heater 412 is located in opening 386. In certain embodiments, opening 386 is a u-shaped opening with a substantially horizontal or inclined section in hydrocarbon layer 388 below overburden 400. Heater 412 may be a u-shaped heater with ends that extend out of both legs of the wellbore. In certain embodiments, heater 412 is an electrical resistance heater (a heater that provides heat by electrical resistance heating when energized with electrical current). In some embodiments, heater 412 is an oxidation heater (for example, a heater that oxidizes (combusts) fluids to produce heat). In certain embodiments, heater 412 is a circulating fluid heater such as a molten salt circulating heater.

[1080] In certain embodiments, heater 412 includes heating section 694. Heating section 694 may be the portion of heater 412 that provides heat to hydrocarbon layer 388. In certain embodiments, heating section 694 is the portion of heater 412 that has a higher electrical resistance than the rest of the heater such that the heating section is the only portion of the heater that provides substantial heat output to hydrocarbon layer 388. In some embodiments, heating section 694 is the portion of the heater that includes a downhole oxidizer (for example, downhole burner) or a plurality of downhole oxidizers. Other portions of heater 412 may be non-heating portions of the heater (for example, lead-in or lead-out sections of the heater) or portions of the heater that provide negligible heat output.

[1081] In certain embodiments, heater 412 is similar in length to the horizontal portion of opening 386 and heating section 694 is the portion of heater 412 shown in FIG. 132. Thus, heating section 694 is short in length compared to the horizontal portion of opening 386. In some embodiments, heating section 694 extends along the entire horizontal portion of heater 412 (or nearly the entire horizontal portion of the heater) and the heater is short in length compared to the horizontal portion of opening 386 such that the heating section is shorter in length than the horizontal portion of the opening.

[1082] In some embodiments, heating section 694 is at most $\frac{1}{2}$ the length of the horizontal portion of opening 386, at most $\frac{1}{4}$ the length of the horizontal portion of opening 386, or at most $\frac{1}{5}$ the length of the horizontal portion of opening 386. For example, the horizontal portion of opening 386 in hydrocarbon layer 388 may be between about 1500 m and about

3000 m in length and heating section 694 may be between about 300 m and about 500 m in length.

[1083] Having shorter heating section 694 allows heat to be provided to a small portion of hydrocarbon layer 388. The portion of hydrocarbon layer 388 heated by heating section 694 may be first volume 696. First volume 696 may be created around heater 412 proximate heating section 694.

[1084] In certain embodiments, heater 412 and heating section 694 are moved to provide heat to another portion of the formation. FIG. 133 depicts heater 412 with heating section 694 moved to heat second volume 698. In some embodiments, heating section 694 is moved by pulling heater 412 from one end of opening 386 (for example, pulling the heater from the left end of the opening, as shown in FIG. 133). In certain embodiments, heater 412 and heating section 694 are moved further to provide heat to third volume 700, as shown in FIG. 134.

[1085] In certain embodiments, first volume 696, second volume 698, and third volume 700 are heated sequentially from the first volume to the third volume. In some embodiments, portions of the volumes may overlap depending on the moving rate (movement speed) of heater 412 and heating section 694. In certain embodiments, heater 412 and heating section 694 are moved at a controlled rate. For example, heater 412 and heating section 694 may be moved after treating first volume 696 for a selected period of time or after a selected temperature is reached in the first volume.

[1086] Moving heater 412 and heating section 694 at the controlled rate may provide controlled heating in hydrocarbon layer 388. In some embodiments, the moving rate is controlled to control the amount of mobilization in hydrocarbon layer 388, first volume 696, second volume 698, and/or third volume 700. In some embodiments, the moving rate is controlled to control the amount of pyrolyzation in hydrocarbon layer 388, first volume 696, second volume 698, and/or third volume 700. The movement rate when mobilizing may be faster than the moving rate when pyrolyzing as more heat needs to be provided in a selected volume of the formation to result in pyrolyzation of hydrocarbons in the selected volume. In general, the moving rate of heater 412 and heating section 694 is controlled to achieve desired heating results for treatment of hydrocarbon layer 388. The moving rate may be determined, for example, by assessing treatment of hydrocarbon layer 388 using simulations and/or other calculations.

[1087] In certain embodiments, heater 412 is a u-shaped heater that is moved (for example, pulled) through u-shaped opening 386, as shown in FIGS. 132-134. In some embodiments, heater 412 is an L-shaped or J-shaped heater that is moved through a u-shaped opening (for example, the heater may be shaped like the heater depicted in FIG. 134). The L-shaped or J-shaped heater may be moved by either pulling or pushing the heater from either end of the u-shaped opening.

[1088] In some embodiments, heater 412 is an L-shaped or J-shaped heater that is moved through an L-shaped or J-shaped opening. FIGS. 135-137 depict movement of L-shaped or J-shaped heater 412 as the heater is moved through opening 386 to heat first volume 696, second volume 698, and third volume 700.

[1089] FIG. 138 depicts an embodiment with two heaters 412A, 412B located in u-shaped opening 386. Heaters 412A, 412B may have heating sections 694A, 694B, respectively. Heaters 412A, 412B and heating sections 694A, 694B may be moved (pulled) away from each other, as shown by the arrows in FIG. 138. Moving heating sections 694A, 694B in opposite

directions may create heated volumes in hydrocarbon layer **388** on each side of the middle of opening **386**. In some embodiments, the heated volumes created by heating section **694A** may substantially mirror the heated volumes created by heating section **694B**. Thus, mirrored heated volumes may be sequentially created going in opposite directions from the middle of opening **386** by moving heating sections **694A**, **694B** away from each other at a controlled rate.

[1090] In certain embodiments, movable heaters allow for closer spacing between heaters during early phases of in situ heat treatment without increasing the number of wellbores in the formation by overlapping heating sections during the early phases of treatment. FIG. **139** depicts a top view of treatment area **666** treated using non-overlapping heating sections **694A**, **694B** in heaters **412A**, **412B**. As shown in FIG. **139**, heaters **412A**, **412B** are L-shaped or J-shaped heaters located substantially horizontal or at an incline in the formation. Heaters **412A**, **412B** extend from build sections **702A**, **702B**, respectively.

[1091] In an embodiment, heating sections **694A**, **694B** heat in two phases. The solid sections of heaters **412A**, **412B**, shown as heating sections **694A**, **694B** in FIG. **139**, are the first phase of heating. The solid sections provide heat in the center portion of treatment area **666**. Heating sections **694A**, **694B** in the first phase are located end-to-end (the ends of the heating sections abut but do not touch) and do not overlap, as shown in FIG. **139**. The cross-hatched sections of heaters **412A**, **412B** are the second phase of heating. In the second phase of heating, heating sections **694A**, **694B** move into the cross-hatched sections of heaters **412A**, **412B** to heat the edge portions of treatment area **666**. In the embodiment depicted in FIG. **139**, **18** heaters **412A**, **412B** are used to heat treatment area **666**.

[1092] FIG. **140** depicts a top view of treatment area **666** treated using overlapping heating sections **694A**, **694B** in the first phase of heating using heaters **412A**, **412B**. In the embodiment depicted in FIG. **140**, heaters **412A**, **412B** heat treatment area **666** in two phases such as in the embodiment depicted in FIG. **139**. In the first phase, however, heating sections **694A**, **694B** overlap and are located adjacent to each other, as shown in FIG. **140**. Thus, heating sections **694A**, **694B** (and heaters **412A**, **412B**) have closer spacing during the first phase in the embodiment depicted in FIG. **140** than the embodiment depicted in FIG. **139**. For example, heating sections **694A**, **694B** shown in FIG. **140** have half the spacing of the heating sections shown in FIG. **139**. In addition, heat provided by heating sections **694A** during the first phase in the embodiment depicted in FIG. **140** overlaps with heat provided by heating sections **694B**, which also increases the heat provided to the center portion of treatment area **666**. The closer spacing may accelerate heating of the center portion of treatment area **666** without increasing the number of heaters **412A**, **412B** in the treatment area (there are still **18** heaters in the embodiment depicted in FIG. **140**). In addition, heat provided by heating sections **694A** during the first phase in the embodiment depicted in FIG. **140** overlaps with heat provided by heating sections **694B**, which increases the heat provided to the center portion of treatment area **666**. During the second phase of heating, heating sections **694A**, **694B** (the cross-hatched sections) in the embodiment depicted in FIG. **140** may have similar spacing as the second phase heating sections in the embodiment depicted in FIG. **139**.

[1093] As shown in the embodiment depicted in FIG. **140**, build section **702B** may be moved closer to build section

702A in order to achieve the closer heater spacing in the first phase of heating. Thus, the volume of treatment area **666** heated during the two phases of heating may be smaller than the volume heated in the embodiment depicted in FIG. **139**. In certain embodiments, additional heaters may be placed in remaining volume **704** of treatment area **666**. These additional heaters may heat remaining volume **704** such that a similar volume of treatment area **666** is heated in the embodiment depicted in FIG. **140** as the volume heated in the embodiment depicted in FIG. **139**. The additional heaters used to heat remaining volume **704**, depicted in FIG. **140**, may be placed in the formation at later times during treatment of the formation. The additional heaters may have a discounted cost compared to heaters formed in the formation at earlier times.

[1094] In some embodiments, fast fluidized transport line systems may be used for subsurface heating. Fast fluidized transport line systems may have significantly higher overall energy efficiency as compared to using electrical heating. The systems may have high heat transfer efficiency. Low value fuel (for example, bitumen or pulverized coal) may be used as the heat source. Solid transport line circulation is commercially proven technology having relatively reliable operation.

[1095] Fast fluidized transport systems may include one or more combustion units, wellbores, a treatment area, and piping to transport fluidized material from the combustion units through the wellbores to heat the treatment area. In some embodiments, one or more of combustion units used to heat the formation are furnaces, nuclear reactors, or other high temperature heat sources. Such combustion units heat fluidized material that passes through the combustion units. Each combustion unit may provide hot fluidized material to a large number of u-shaped wellbores. For example, one combustion unit may supply hot fluidized material to 20 or more u-shaped wellbores. In some embodiments, the u-shaped wellbores are formed so that the surface footprint has long rows of inlet and exit legs of u-shaped wellbores. The exit legs and inlet legs of these u-shaped wellbores are located in adjacent rows. Additional fluidized transport systems would be located on the same row to supply all of the u-shaped wellbores on the row. Also, additional fluidized transport systems would be positioned on adjacent rows to supply inlet legs and outlet legs of the adjacent rows.

[1096] Fluidized material may include coal particles (for example, pulverized coal), other hydrocarbon or carbon containing material (for example, bitumen and coke), and heat carrier particles. The heat carrier particles may include, but are not limited to, sand, silica, ceramic particles, waste fluidized catalytic cracking catalyst, other particles used for heat transfer, or mixtures thereof. In some embodiments, the particle range distribution of the fluidized material may span from between about 5 and 200 microns.

[1097] A portion of the hydrocarbon content in fluidized material may combust and/or pyrolyze in the combustion units. Fluidized material may still have a significant carbon (coke) and/or hydrocarbon content after passing through the combustion unit. The oxidant may react with the carbon and/or hydrocarbons in the fluidized material in the u-shaped conduits. The combustion of hydrocarbons and carbon in the fluidized material may maintain a high temperature of the fluidized material and/or generate heat that transfers to the formation.

[1098] Gas lifting may facilitate transport of the fluidized material in the u-shaped conduits. Multiple valves in the

outlet legs may allow entry of lift gas into the outlet legs to transport the fluidized material to the treatment area. In some embodiments, the lift gas is air. Other gases may be used as the lift gas.

[1099] In some in situ heat treatment process embodiments, a circulation system is used to heat the formation. Using the circulation system for in situ heat treatment of a hydrocarbon containing formation may reduce energy costs for treating the formation, reduce emissions from the treatment process, and/or facilitate heating system installation. In certain embodiments, the circulation system is a closed loop circulation system. FIG. 141 depicts a schematic representation of a system for heating a formation using a circulation system. The system may be used to heat hydrocarbons that are relatively deep in the ground and that are in formations that are relatively large in extent. In some embodiments, the hydrocarbons may be 100 m, 200 m, 300 m or more below the surface. The circulation system may also be used to heat hydrocarbons that are shallower in the ground. The hydrocarbons may be in formations that extend lengthwise up to 1000 m, 3000 m, 5000 m, or more. The heaters of the circulation system may be positioned relative to adjacent heaters such that superposition of heat between heaters of the circulation system allows the temperature of the formation to be raised at least above the boiling point of aqueous formation fluid in the formation.

[1100] In some embodiments, heaters 412 are formed in the formation by drilling a first wellbore and then drilling a second wellbore that connects with the first wellbore. Piping may be positioned in the u-shaped wellbore to form u-shaped heater 412. Heaters 412 are connected to heat transfer fluid circulation system 706 by piping. In some embodiments, the heaters are positioned in triangular patterns. In some embodiments, other regular or irregular patterns are used. Production wells and/or injection wells may also be located in the formation. The production wells and/or the injection wells may have long, substantially horizontal sections similar to the heating portions of heaters 412, or the production wells and/or injection wells may be otherwise oriented (for example, the wells may be vertically oriented wells, or wells that include one or more slanted portions).

[1101] As depicted in FIG. 141, heat transfer fluid circulation system 706 may include heat supply 708, first heat exchanger 710, second heat exchanger 712, and fluid movers 714. Heat supply 708 heats the heat transfer fluid to a high temperature. Heat supply 708 may be a furnace, solar collector, chemical reactor, nuclear reactor, fuel cell, and/or other high temperature source able to supply heat to the heat transfer fluid. If the heat transfer fluid is a gas, fluid movers 714 may be compressors. If the heat transfer fluid is a liquid, fluid movers 714 may be pumps.

[1102] After exiting formation 492, the heat transfer fluid passes through first heat exchanger 710 and second heat exchanger 712 to fluid movers 714. First heat exchanger 710 transfers heat between heat transfer fluid exiting formation 492 and heat transfer fluid exiting fluid movers 714 to raise the temperature of the heat transfer fluid that enters heat supply 708 and reduce the temperature of the fluid exiting formation 492. Second heat exchanger 712 further reduces the temperature of the heat transfer fluid. In some embodiments, second heat exchanger 712 includes or is a storage tank for the heat transfer fluid.

[1103] Heat transfer fluid passes from second heat exchanger 712 to fluid movers 714. Fluid movers 714 may be

located before heat supply 708 so that the fluid movers do not have to operate at a high temperature.

[1104] In an embodiment, the heat transfer fluid is carbon dioxide. Heat supply 708 is a furnace that heats the heat transfer fluid to a temperature in a range from about 700° C. to about 920° C., from about 770° C. to about 870° C., or from about 800° C. to about 850° C. In an embodiment, heat supply 708 heats the heat transfer fluid to a temperature of about 820° C. The heat transfer fluid flows from heat supply 708 to heaters 412. Heat transfers from heaters 412 to formation 492 adjacent to the heaters. The temperature of the heat transfer fluid exiting formation 492 may be in a range from about 350° C. to about 580° C., from about 400° C. to about 530° C., or from about 450° C. to about 500° C. In an embodiment, the temperature of the heat transfer fluid exiting formation 492 is about 480° C. The metallurgy of the piping used to form heat transfer fluid circulation system 706 may be varied to significantly reduce costs of the piping. High temperature steel may be used from heat supply 708 to a point where the temperature is sufficiently low so that less expensive steel can be used from that point to first heat exchanger 710. Several different steel grades may be used to form the piping of heat transfer fluid circulation system 706.

[1105] In some embodiments, solar salt (for example, a salt containing 60 wt % NaNO₃ and 40 wt % KNO₃) is used as the heat transfer fluid in the circulated fluid system. Solar salt may have a melting point of about 230° C. and an upper working temperature limit of about 565° C. In some embodiments, LiNO₃ (for example, between about 10% by weight and about 30% by weight LiNO₃) may be added to the solar salt to produce tertiary salt mixtures with wider operating temperature ranges and lower melting temperatures with only a slight decrease in the maximum working temperature as compared to solar salt. The lower melting temperature of the tertiary salt mixtures may decrease the preheating requirements and allow the use of pressurized water and/or pressurized brine as a heat transfer fluid for preheating the piping of the circulation system. The corrosion rates of the metal of the heaters due to the tertiary salt compositions at 550° C. is comparable to the corrosion rate of the metal of the heaters due to solar salt at 565° C. TABLE 5 shows melting points and upper limits for solar salt and tertiary salt mixtures. Aqueous solutions of tertiary salt mixtures may transition into a molten salt upon removal of water without solidification, thus allowing the molten salt to be provided and/or stored as aqueous solutions.

TABLE 5

NO ₃ Salt	Composition of NO ₃ Salt (weight %)	Melting Point (° C.) of NO ₃ salt	Upper working temperature limit (° C.) of NO ₃ salt
Na:K	60:40	230	600
Li:Na:K	12:18:70	200	550
Li:Na:K	20:28:52	150	550
Li:Na:K	27:33:40	160	550
Li:Na:K	30:18:52	120	550

[1106] In certain embodiments, heat supply 708 is a furnace that heats the heat transfer fluid to a temperature of about 560° C. The return temperature of the heat transfer fluid may be from about 350° C. to about 450° C. Piping from heat transfer fluid circulation system 706 may be insulated and/or heat traced to facilitate startup and to ensure fluid flow.

[1107] In some embodiments, vertical, slanted, or L-shaped wellbores are used instead of u-shaped wellbores (for example, wellbores that have an entrance at a first location and an exit at another location). FIG. 142 depicts L-shaped heater 412. Heater 412 may be coupled to heat transfer fluid circulation system 706 and may include inlet conduit 716, and outlet conduit 718. Heat transfer fluid circulation system 706 may supply heat transfer fluid to multiple heaters. Heat transfer fluid from heat transfer fluid circulation system 706 may flow down inlet conduit 716 and back up outlet conduit 718. Inlet conduit 716 and outlet conduit 718 may be insulated through overburden 400. In some embodiments, inlet conduit 716 is insulated through overburden 400 and hydrocarbon containing layer 388 to inhibit undesired heat transfer between ingoing and outgoing heat transfer fluid.

[1108] In some embodiments, portions of wellbore 490 adjacent to overburden 400 are larger than portions of the wellbore adjacent to hydrocarbon containing layer 388. Having a larger opening adjacent to the overburden may allow for accommodation of insulation used to insulate inlet conduit 716 and/or outlet conduit 718. Some heat loss to the overburden from the return flow may not affect the efficiency significantly, especially when the heat transfer fluid is molten salt or another fluid that needs to be heated to remain a liquid. The heated overburden adjacent to heater 412 may maintain the heat transfer fluid as a liquid for a significant time should circulation of heat transfer fluid stop. Having some allowance for heat transfer to overburden 400 may eliminate the need for expensive insulation systems between outlet conduit 718 and the overburden. In some embodiments, insulative cement is used between overburden 400 and outlet conduit 718.

[1109] For vertical, slanted, or L-shaped heaters, the wellbores may be drilled longer than needed to accommodate non-energized heaters (for example, installed but inactive heaters). Thermal expansion of the heaters after energization may cause portions of the heaters to move into the extra length of the wellbores designed to accommodate the thermal expansion of the heaters. For L-shaped heaters, remaining drilling fluid and/or formation fluid in the wellbore may facilitate movement of the heater deeper into the wellbore as the heater expands during preheating and/or heating with heat transfer fluid.

[1110] For vertical or slanted wellbores, the wellbores may be drilled deeper than needed to accommodate the non-energized heaters. When the heater is preheated and/or heated with the heat transfer fluid, the heater may expand into the extra depth of the wellbore. In some embodiments, an expansion sleeve may be attached at the end of the heater to ensure available space for thermal expansion in case of unstable boreholes.

[1111] FIG. 143 depicts a schematic representation of an embodiment of a portion of vertical heater 412. Heat transfer fluid circulation system 706 may provide heat transfer fluid to inlet conduit 716 of heater 412. Heat transfer fluid circulation system 706 may receive heat transfer fluid from outlet conduit heat 718. Inlet conduit 716 may be secured to outlet conduit 718 by welds 720. Inlet conduit 716 may include insulating sleeve 722. Insulating sleeve 722 may be formed of a number of sections. Each section of insulating sleeve 722 for inlet conduit 716 is able to accommodate the thermal expansion caused by the temperature difference between the temperature of the inlet conduit and the temperature outside the insu-

lating sleeve. Change in length of inlet conduit 716 and insulation sleeve 722 due to thermal expansion is accommodated in outlet conduit 718.

[1112] Outlet conduit 718 may include insulating sleeve 722'. Insulating sleeve 722' may end near the boundary between overburden 400 and hydrocarbon layer 388. In some embodiments, insulating sleeve 722' is installed using a coiled tubing rig. An upper first portion of insulating sleeve 722' may be secured to outlet conduit 718 above or near wellhead 392 by weld 720. Heater 412 may be supported in wellhead 392 by a coupling between the outer support member of insulating sleeve 722' and the wellhead. The outer support member of insulating sleeve 722' may have sufficient strength to support heater 412.

[1113] In some embodiments, insulating sleeve 722' includes a second portion (insulating sleeve portion 722'') that is separate and lower than the first portion of insulating sleeve 722'. Insulating sleeve portion 722'' may be secured to outlet conduit 718 by welds 720 or other types of seals that can withstand high temperatures below packer 724. Welds 720 between insulating sleeve portion 722'' and outlet conduit 718 may inhibit formation fluid from passing between the insulating sleeve and the outlet conduit. During heating, differential thermal expansion between the cooler outer surface and the hotter inner surface of insulating sleeve 722' may cause separation between the first portion of the insulating sleeve and the second portion of the insulating sleeve (insulating sleeve portion 722''). This separation may occur adjacent to the overburden portion of heater 412 above packer 724. Insulating cement between casing 398 and the formation may further inhibit heat loss to the formation and improve the overall energy efficiency of the system.

[1114] Packer 724 may be a polished bore receptacle. Packer 724 may be fixed to casing 398 of wellbore 490. In some embodiments, packer 724 is 1000 m or more below the surface. Packer 724 may be located at a depth above 1000 m, if desired. Packer 724 may inhibit formation fluid from flowing from the heated portion of the formation up the wellbore to wellhead 392. Packer 724 may allow movement of insulating sleeve portion 722'' downwards to accommodate thermal expansion of heater 412.

[1115] In some embodiments, wellhead 392 includes fixed seal 726. Fixed seal 726 may be a second seal that inhibits formation fluid from reaching the surface through wellbore 490 of heater 412.

[1116] FIG. 144 depicts a schematic representation of another embodiment of a portion of vertical heater 412 in wellbore 490. The embodiment depicted in FIG. 144 is similar to the embodiment depicted in FIG. 143, but fixed seal 726 is located adjacent to overburden 400, and sliding seal 728 is located in wellhead 392. The portion of insulating sleeve 722' from fixed seal 726 to wellhead 392 is able to expand upward out of the wellhead to accommodate thermal expansion. The portion of heater located below fixed seal 726 is able to expand into the excess length of wellbore 490 to accommodate thermal expansion.

[1117] In some embodiments, the heater includes a flow switcher. The flow switcher may allow the heat transfer fluid from the circulation system to flow down through the overburden in the inlet conduit of the heater. The return flow from the heater may flow upwards through the annular region between the inlet conduit and the outlet conduit. The flow switcher may change the downward flow from the inlet conduit to the annular region between the outlet conduit and the

inlet conduit. The flow switcher may also change the upward flow from the inlet conduit to the annular region. The use of the flow switcher may allow the heater to operate at a higher temperature adjacent to the treatment area without increasing the initial temperature of the heat transfer fluid provided to the heaters.

[1118] For vertical, slanted, or L-shaped heaters where the flow of heat transfer fluid is directed down the inlet conduit and returns through the annular region between the inlet conduit and the outlet conduit, a temperature gradient may form in the heater with the hottest portion being located at a distal end of the heater. For L-shaped heaters, horizontal portions of a set of first heaters may be alternated with the horizontal portions of a second set of heaters. The hottest portions used to heat the formation of the first set of heaters may be adjacent to the coldest portions used to heat the formation of the second set of heaters, while the hottest portions used to heat the formation of the second set of heaters are adjacent to the coldest portions used to heat the formation of the first set of heaters. For vertical or slanted heaters, flow switchers in selected heaters may allow the heaters to be arranged with the hottest portions used to heat the formation of first heaters adjacent to coldest portions used to heat the formation of second heaters. Having hottest portions used to heat the formation of the first set of heaters adjacent to coldest portions used to heat the formation of the second set of heaters may allow for more uniform heating of the formation.

[1119] In certain embodiments, treatment areas in a formation are treated in patterns (for example, regular or irregular patterns). FIG. 145 depicts a schematic representation of a corridor pattern system used to treat treatment area 730. Heat transfer circulation systems 706, 706' may be positioned on each side of treatment area 730. Inlet wellheads 732 and outlet wellheads 734 of subsurface heaters 412 may be positioned in rows along each side of the treatment area. Although one row of wellheads is depicted on each side of treatment area 730, sufficient wells may be formed in the formation such that heaters 412 in the formation form a three dimensional pattern in the treatment area with well spacings that allow for superposition of heat from adjacent heaters. Hot heat transfer fluid from circulation system 706 flows through manifolds to inlet wellheads 732 on the first side of treatment area 730. The heat transfer fluid passes through heaters 412 to outlet wellbores 734 on the second side of treatment area 730. Heat is transferred from the heat transfer fluid to treatment area 730 as the heat transfer fluid travels from inlet wellheads 732 to outlet wellheads 734. The heat transfer fluid passes from outlet wellheads 734 through manifolds to heat transfer fluid circulation system 706' on the second side of treatment area 730. Additional corridor patterns above, below, and/or to the sides of treatment area 730 may be processed during or after in heat situ treatment of treatment area 730.

[1120] FIG. 146 depicts a schematic representation of a radial pattern system used to treat treatment area 730. Treatment area 730 may be an annular region located between inlet wellheads 732 and outlet wellheads 734. Central heat transfer fluid circulation system 706 may be positioned near to or on a first side (for example, at or near the center or on the inside) of treatment area 730. Outer heat transfer fluid circulation systems 706' may be positioned near to or on a second side (for example, on the perimeter) of treatment area 730. Inlet wellheads 732 and outlet wellheads 734 of subsurface heaters 412 may be positioned in rings along each side of the treatment area. Although one ring of inlet wellheads 732 and one

ring of outlet wellheads 734 is depicted on each side of treatment area 730, sufficient wells may be formed in the formation such that heaters 412 in the formation form a three-dimensional pattern in the treatment area with well spacings that allow for superposition of heat between adjacent heaters. Hot heat transfer fluid from central heat transfer fluid circulation system 706 flows through manifolds to inlet wellheads on the first side of treatment area 730. The heat transfer fluid passes through heaters 412 to outlet wellbores 734 on the second side of treatment area 730. Heat is transferred from the heat transfer fluid to the treatment area as the heat transfer fluid travels from inlet wellheads 732 to outlet wellheads 734. The heat transfer fluid passes from outlet wellheads 734 on the second side of treatment area 730 through manifolds to outer heat transfer fluid circulation systems 706' on the second side of the treatment area. Heat transfer fluid heated by outer heat transfer fluid circulation systems 706' passes through manifolds to inlet wellheads 732 on the second side of the treatment area. The heat transfer fluid passes through heaters 412 to outlet wellheads 734 on the first side of treatment area 730. The heat transfer fluid flows through manifolds to central heat transfer fluid circulation system 706. In certain embodiments, additional radial patterns are formed at other locations in the formation.

[1121] In some embodiments, only a portion of the ring of treatment area 730 is treated. In some embodiments, the entire ring of the treatment area, or a portion of the treatment area is treated in sections. For example, one or more central circulation systems 706 may supply heat transfer fluid to a first set of heaters. The first set of heaters, along with a second set of return heaters may treat a first section of about one eighth (or 45° arc) of the treatment area. Other section sizes may also be chosen. The heat transfer fluid from central circulation systems 706 may be received by one or more outer circulation systems 706'. Outer circulation systems 706' may return heat transfer fluid to central circulation systems 706. After completion of heating of the first section of treatment area 730, an adjacent section to the first section or another section of the treatment area not adjacent to the first section may be treated. Outer circulation systems 706' may be mobile such that the outer circulation systems can be used to treat different sections of the treatment area. In some embodiments, one or more production wells for a particular section may be used to produce formation fluid during the treatment of another section.

[1122] Due to the radial layout of heaters 412, the heater density and/or heat input per volume of formation increases from the second side of treatment area 730 towards the first side of the treatment area. The heater density and/or heat input per volume change may establish a temperature gradient through treatment area 730 with the average temperature of the treatment area increasing from the second side of the treatment area towards the first side of the treatment area (for example, from the perimeter of the treatment area towards the center of the treatment area). For example, the average temperature near the first side of treatment area 730 may be about 300° C. to about 350° C. while the average temperature near the second side may be about 180° C. to about 220° C. The higher temperature near the first side of treatment area 730 may result in the mobilization of hydrocarbons towards the second side of the treatment area.

[1123] FIG. 147 depicts a plan view of an embodiment of wellbore openings on a first side of treatment area 730. Heat transfer fluid entries 736 into the formation alternate with

heat transfer fluid exits **738**. Alternating heat transfer fluid entries **736** and heat transfer fluid exits **738** may allow for more uniform heating of the hydrocarbons in treatment area **730**.

[1124] In some embodiments, piping and surface facilities for the circulation system may allow the direction of heat transfer fluid flow through the formation to be changed. Changing the direction of heat transfer fluid flow through the formation allows each end of a u-shaped wellbore to alternately receive the heat transfer fluid at the hottest temperature of the heat transfer fluid for a period of time, which may result in more uniform heating of the formation. The direction of heat transfer fluid may be changed at desired time intervals. The desired time interval may be, for example, about a year, about six months, about three months, about two months, or any other desired time interval.

[1125] In some embodiments, a liquid heat transfer fluid is used as the heat transfer fluid. The liquid heat transfer fluid may be natural or synthetic oil, molten metal, molten salt, or another type of high temperature heat transfer fluid. A liquid heat transfer fluid may allow for smaller diameter piping and reduced pumping and/or compression costs. In some embodiments, the piping is made of a material resistant to corrosion by the liquid heat transfer fluid. In some embodiments, the piping is lined with a material that is resistant to corrosion by the liquid heat transfer fluid. For example, if the heat transfer fluid is a molten fluoride salt, the piping may include nickel liner (for example, a 10 mil thick nickel liner). Such piping may be formed by roll bonding a nickel strip onto a strip of the piping material (for example, stainless steel), rolling the composite strip, and longitudinally welding the composite strip to form the piping. Other techniques known in the art may also be used. Nickel corrosion by the molten fluoride salt may be at most 1 mil per year at a temperature of about 840° C.

[1126] In some embodiments, two or more heat transfer fluids (for example, air, superheated steam, synthetic heat transfer oils, and/or molten salts) are employed to transfer thermal energy to and/or from a hydrocarbon containing formation. In some embodiments, a first heat transfer fluid is a synthetic heat transfer oil (for example, DowTherm®A manufactured by Dow Chemical Company, USA). A first heat transfer fluid may be heated, for example, with a nuclear reactor or a furnace. The first heat transfer fluid may be circulated through a plurality of wellbores in at least a portion of the formation in order to heat the portion of the formation. The first heat transfer fluid may have a first temperature range in which the first heat transfer fluid is in a liquid form and stable. Temperature of the first heat transfer fluid may be in a range from about 150° C. to about 400° C. An inlet of the piping may be heated to a predetermined temperature (for example, heated to a temperature in a range from about 400° C. to about 600° C.). The first heat transfer fluid may be circulated through the portion of the formation until the portion reaches a temperature in a desired temperature range (for example, about 230° C. or a temperature towards the upper end of the first heat transfer fluid temperature range). The first heat transfer fluid may be circulated through the piping in the formation at, for example, a rate of 3 kg/sec to 15 kg/sec, a rate of 4 kg/sec to 12 kg/sec, or a rate of 5 kg/sec to 10 kg/sec. A flow rate of the first heat transfer fluid may be selected based on, for example, the number of days desired for preheating (for example, 10 days, 50 days, or 120 days) and the inlet temperature of the piping. For example, air may be circulated at 6.2 kg/sec through a 5" diameter U-shaped

heater having an inlet temperature of 600° C. to preheat a section of a formation to 230° C. in 10 days. Circulating synthetic heat transfer oil at a flow rate of 4.3 kg/sec may preheat the section in the same period of time. To preheat the section to 230° C. in 10 days using superheated steam as the heat transfer fluid, a flow rate of 3.2 kg/sec may be used.

[1127] A second heat transfer fluid may be heated (for example, with a nuclear reactor). The second heat transfer fluid may have a second temperature range in which the second heat transfer fluid is in a liquid form and stable. An upper end of the second temperature range may be hotter and above the first temperature range. A lower end of the second temperature range may overlap with the first temperatures range. The second heat transfer fluid may be circulated through the plurality of wellbores in the portion of the formation in order to heat the portion of the formation to a higher temperature than is possible with the first heat transfer fluid.

[1128] The advantages of using two or more different heat transfer fluids may include, for example, the ability to heat the portion of the formation to a much higher temperature than is normally possible while using other supplementary heating methods (for example, electric heaters) as little as possible to increase overall efficiency (for example, electric heaters). Using two or more different heat transfer fluids may be necessary if a heat transfer fluid with a large enough temperature range capable of heating the portion of the formation to the desired temperature is not available. Heating with two or more heat transfer fluids may deliver greater than 1000 W/ft of energy to the formation, thus allowing the formation to be preheated in a relatively short period of time (for example, less than 120 days).

[1129] In some embodiments, after the portion of the hydrocarbon containing formation has been heated to a desired temperature range, the first heat transfer fluid may be recirculated through the portion of the formation. The first heat transfer fluid may not be heated before recirculation through the formation (other than heating the heat transfer fluid to the melting point if necessary in the case of molten salts). The first heat transfer fluid may be heated using the thermal energy already stored in the portion of the formation from prior in situ heat treatment of the formation. The first heat transfer fluid may then be transferred out of the formation such that the thermal energy recovered by the first heat transfer fluid may be reused for some other process in the portion of the formation, in a second portion of the formation, and/or in an additional formation.

[1130] In some embodiments, the diameter of the conduit through which the heat transfer fluid flows in overburden **400** may be smaller than the diameter of the conduit through the treatment area. For example, the diameter of the pipe in the overburden may be about 3" (about 7.6 cm), and the diameter of the pipe adjacent to the treatment area may be about 5" (about 12.7 cm). The smaller diameter pipe through overburden **400** may reduce heat loss from the heat transfer fluid to the overburden. Reducing heat loss to overburden **400** reduces cooling of the heat transfer fluid supplied to the conduit adjacent to hydrocarbon layer **388**. In certain embodiments, any increased heat loss in the smaller diameter pipe due to increased velocity of the heat transfer fluid through the smaller diameter pipe is offset by the smaller surface area of the smaller diameter pipe and the decrease in residence time of the heat transfer fluid in the smaller diameter pipe.

[1131] Heat transfer fluid from heat supply **708** of heat transfer fluid circulation system **706** passes through overbur-

den **400** of formation **492** to hydrocarbon layer **388**. In certain embodiments, portions of heaters **412** extending through overburden **400** are insulated. In some embodiments, the insulation or part of the insulation is a polyimide insulating material. In some embodiments, inlet portions of heaters **412** in hydrocarbon layer **388** have tapering insulation to reduce overheating of the hydrocarbon layer near the inlet of the heater into the hydrocarbon layer.

[1132] The overburden section of heaters **412** may be insulated to prevent or inhibit heat loss into non-hydrocarbon bearing zones of the formation. In some embodiments, thermal insulation is provided by a conduit-in-conduit design. The heat transfer fluid flows through the inner conduit. Insulation fills the space between the inner conduit and the outer conduit. An effective insulation may be a combination of metal foil to inhibit radiative heat loss and microporous silica powder to inhibit conductive heat loss. Reducing the pressure in the space between the inner conduit and the outer conduit by pulling a vacuum during assembly and/or with getters may further reduce heat losses when using the conduit-in-conduit design. To account for the differential thermal expansion of the inner conduit and the outer conduit, the inner conduit may be pre-stressed or made of a material with low thermal expansion (for example, Invar alloys). The insulated conduit-in-conduit may be installed continuously in conjunction with coiled tubing installation. Insulated conduit-in-conduit systems may be available from Industrial Thermo Polymers Limited (Ontario, Canada) and Oil Tech Services, Inc. (Houston, Tex., U.S.A.). Other effective insulation materials include, but are not limited to, ceramic blankets, foam cements, cements with low thermal conductivity aggregates (such as vermiculite), Izoflex™ insulation, and aerogel/glass-fiber composites such as those provided by Aspen Aerogels, Inc. (Northborough, Mass., U.S.A.).

[1133] FIG. **148** depicts a cross-sectional view of an embodiment of overburden insulation. Insulating cement **740** may be placed between casing **398** and formation **492**. Insulating cement **740** may also be placed between heat transfer fluid conduit **742** and casing **398**.

[1134] FIG. **149** depicts a cross-sectional view of an alternate embodiment of overburden insulation that includes insulating sleeve **722** around heat transfer fluid conduit **742**. Insulating sleeve **722** may include, for example, an aerogel. Gap **744** may be located between insulating sleeve **722** and casing **398**. The emissivities of insulating sleeve **722** and casing **398** may be low to inhibit radiative heat transfer in gap **744**. A non-reactive gas may be placed in gap **744** between insulating sleeve **722** and casing **398**. Gas in gap **744** may inhibit conductive heat transfer between insulating sleeve **722** and casing **398**. In some embodiments, a vacuum may be drawn and maintained in gap **744**. Insulating cement **740** may be placed between casing **398** and formation **492**. In some embodiments, insulating sleeve **722** has a significantly smaller thermal conductivity value than the thermal conductivity value of insulating cement. In certain embodiments, the insulation provided by the insulation depicted in FIG. **149** may be better than the insulation provided by the insulation depicted in FIG. **148**.

[1135] FIG. **150** depicts a cross-sectional view of an alternate embodiment of overburden insulation with insulating sleeve **722** around heat transfer fluid conduit **742**, vacuum gap **746** between the insulating sleeve and conduit **748**, and gap **744** between the conduit and casing **398**. Insulating cement **740** may be placed between casing **398** and formation **492**. A

non-reactive gas may be placed in gap **744** between conduit **748** and casing **398**. In some embodiments, a vacuum may be drawn and maintained in gap **744**. A vacuum may be drawn and maintained in vacuum gap **746** between insulating sleeve **722** and conduit **748**. Insulating sleeve **722** may include layers of insulating material separated by foil **750**. The insulation material may be, for example, aerogel. The layers of insulating material separated by foil **750** may provide substantial insulation around heat transfer fluid conduit **742**. Vacuum gap **746** may inhibit radiative, convective, and/or conductive heat transfer between insulating sleeve **722** and conduit **748**. A non-reactive gas may be placed in gap **744**. The emissivities of conduit **748** and casing **398** may be low to inhibit radiative heat transfer between the conduit and the casing. In certain embodiments, the insulation provided by the insulation depicted in FIG. **150** may be better than the insulation provided by the insulation depicted in FIG. **149**.

[1136] When heat transfer fluid is circulated through piping in the formation to heat the formation, the heat of the heat transfer fluid may cause changes in the piping. The heat in the piping may reduce the strength of the piping since Young's modulus and other strength characteristics vary with temperature. The high temperatures in the piping may raise creep concerns, may cause buckling conditions, and may move the piping from the elastic deformation region to the plastic deformation region.

[1137] Heating the piping may cause thermal expansion of the piping. For long heaters placed in the wellbore, the piping may expand 20 m or more. In some embodiments, the horizontal portion of the piping is cemented in the formation with thermally conductive cement. Care may need to be taken to ensure that there are no significant gaps in the cement to inhibit expansion of the piping into the gaps and possible failure. Thermal expansion of the piping may cause ripples in the pipe and/or an increase in the wall thickness of the pipe.

[1138] For long heaters with gradual bend radii (for example, about 10° of bend per 30 m), thermal expansion of the piping may be accommodated in the overburden or at the surface of the formation. After thermal expansion is completed, the position of the heaters relative to the wellheads may be secured. When heating is finished and the formation is cooled, the position of the heaters may be unsecured so that thermal contraction of the heaters does not destroy the heaters.

[1139] FIGS. **151-161** depict schematic representations of various methods for accommodating thermal expansion. In some embodiments, change in length of the heater due to thermal expansion may be accommodated above the wellhead. After substantial changes in the length of the heater due to thermal expansion cease, the heater position relative to the wellhead may be fixed. The heater position relative to the wellhead may remain fixed until the end of heating of the formation. After heating is ended, the position of the heater relative to the wellhead may be freed (unfixed) to accommodate thermal contraction of the heater as the heater cools.

[1140] FIG. **151** depicts a representation of bellows **752**. Length *L* of bellows **752** may change to accommodate thermal expansion and/or contraction of piping **754**. Bellows **752** may be located subsurface or above the surface. In some embodiments, bellows **752** includes a fluid that transfers heat out of the wellhead.

[1141] FIG. **152A** depicts a representation of piping **754** with expansion loop **756** above wellhead **392** for accommodating thermal expansion. Sliding seals in wellhead **392**,

stuffing boxes, or other pressure control equipment of the wellhead allow piping 754 to move relative to casing 398. Expansion of piping 754 is accommodated in expansion loop 756. In some embodiments, two or more expansion loops 756 are used to accommodate expansion of piping 754.

[1142] FIG. 152B depicts a representation of piping 754 with coiled or spooled piping 758 above wellhead 392 for accommodating thermal expansion. Sliding seals in wellhead 392, stuffing boxes, or other pressure control equipment of the wellhead allow piping 754 to move relative to casing 398. Expansion of piping 754 is accommodated in coiled piping 758. In some embodiments, expansion is accommodated by coiling the portion of the heater exiting the formation on a spool using a coiled tubing rig.

[1143] In some embodiments, coiled piping 758 may be enclosed in insulated volume 760, as shown in FIG. 152C. Enclosing coiled piping 758 in insulated volume 760 may reduce heat loss from the coiled piping and fluids inside the coiled piping. In some embodiments, coiled piping 758 has a diameter between 2' (about 0.6 m) and 4' (about 1.2 m) to accommodate up to about 30' (about 9.1 m) of expansion in piping 754.

[1144] FIG. 153 depicts a portion of piping 754 in overburden 400 after thermal expansion of the piping has occurred. Casing 398 has a large diameter to accommodate buckling of piping 754. Insulating cement 740 may be between overburden 400 and casing 398. Thermal expansion of piping 754 causes helical or sinusoidal buckling of the piping. The helical or sinusoidal buckling of piping 754 accommodates the thermal expansion of the piping, including the horizontal piping adjacent to the treatment area being heated. As depicted in FIG. 154, piping 754 may be more than one conduit positioned in large diameter casing 398. Having piping 754 as multiple conduits allows for accommodation of thermal expansion of all of the piping in the formation without increasing the pressure drop of the fluid flowing through piping in overburden 400.

[1145] In some embodiments, thermal expansion of subsurface piping is translated up to the wellhead. Expansion may be accommodated by one or more sliding seals at the wellhead. The seals may include Grafoil® gaskets, Stellite® gaskets, and/or Nitronic® gaskets. In some embodiments, the seals include seals available from BST Lift Systems, Inc. (Ventura, Calif., U.S.A.).

[1146] FIG. 155 depicts a representation of wellhead 392 with sliding seal 728. Wellhead 392 may include a stuffing box and/or other pressure control equipment. Circulated fluid may pass through conduit 742. Conduit 742 may be at least partially surrounded by insulated conduit 722. The use of insulated conduit 722 may obviate the need for a high temperature sliding seal and the need to seal against the heat transfer fluid. Expansion of conduit 742 may be handled at the surface with expansion loops, bellows, coiled or spooled pipe, and/or sliding joints. In some embodiments, packers 762 between insulated conduit 722 and casing 398 seal the wellbore against formation pressure and hold gas for additional insulation. Packers 762 may be inflatable packers and/or polished bore receptacles. In certain embodiments, packers 762 are operable up to temperatures of about 600° C. In some embodiments, packers 762 include seals available from BST Lift Systems, Inc. (Ventura, Calif., U.S.A.).

[1147] In some embodiments, thermal expansion of subsurface piping is handled at the surface with a slip joint that allows the heat transfer fluid conduit to expand out of the

formation to accommodate the thermal expansion. Hot heat transfer fluid may pass from a fixed conduit into the heat transfer fluid conduit in the formation. Return heat transfer fluid from the formation may pass from the heat transfer fluid conduit into the fixed conduit. A sliding seal between the fixed conduit and the piping in the formation, and a sliding seal between the wellhead and the piping in the formation, may accommodate expansion of the heat transfer fluid conduit at the slip joint.

[1148] FIG. 156 depicts a representation of a system where heat transfer fluid in conduit 742 is transferred to or from fixed conduit 764. Insulating sleeve 722 may surround conduit 742. Sliding seal 728 may be between insulated sleeve 722 and wellhead 392. Packers between insulating sleeve 722 and casing 398 may seal the wellbore against formation pressure. Heat transfer fluid seals 790 may be positioned between a portion of fixed conduit 764 and conduit 742. Heat transfer fluid seals 790 may be secured to fixed conduit 764. The resulting slip joint allows insulating sleeve 722 and conduit 742 to move relative to wellhead 392 to accommodate thermal expansion of the piping positioned in the formation. Conduit 742 is also able to move relative to fixed conduit 764 in order to accommodate thermal expansion. Heat transfer fluid seals 790 may be uninsulated and spatially separated from the flowing heat transfer fluid to maintain the heat transfer fluid seals at relatively low temperatures.

[1149] In some embodiments, thermal expansion is handled at the surface with a slip joint where the heat transfer fluid conduit is free to move and the fixed conduit is part of the wellhead. FIG. 157 depicts a representation of a system where fixed conduit 764 is secured to wellhead 392. Fixed conduit 764 may include insulating sleeve 722. Heat transfer fluid seals 790 may be coupled to an upper portion of conduit 742. Heat transfer fluid seals 790 may be uninsulated and spatially separated from the flowing heat transfer fluid to maintain the heat transfer fluid seals at relatively low temperatures. Conduit 742 is able to move relative to fixed conduit 764 without the need for a sliding seal in wellhead 392.

[1150] FIG. 158 depicts an embodiment of seals 790. Seals 790 may include seal stack 766 attached to packer body 768. Packer body 768 may be coupled to conduit 742 using packer setting slips 770 and packer insulation seal 772. Seal stack 766 may engage polished portion 774 of conduit 764. In some embodiments, cam rollers 776 are used to provide support to seal stack 766. For example, if side loads are too large for the seal stack. In some embodiments, wipers 778 are coupled to packer body 768. Wipers 778 may be used to clean polished portion 774 as conduit 764 is inserted through seal 790. Wipers 778 may be placed on the upper side of seals 790, if needed. In some embodiments, seal stack 766 is loaded for better contact using a bow spring or other preloaded means to enhance compression of the seals.

[1151] In some embodiments, seals 790 and conduit 764 are run together into conduit 742. Locking mechanisms such as mandrels may be used to secure the seals and the conduits in place. FIG. 159 depicts an embodiment of seals 790, conduit 742, and conduit 764 secured in place with locking mechanisms 780. Locking mechanisms 780 include insulation seals 782 and locking slips 784. Locking mechanisms 780 may be activated as seals 790 and conduit 764 enter into conduit 742.

[1152] As locking mechanisms 780 engage a selected portion of conduit 742, springs in the locking mechanisms are activated and open and expose insulation seals 782 against

the surface of conduit **742** just above locking slips **784**. Locking mechanisms **780** allow insulations seals **782** to be retracted as the assembly is moved into conduit **742**. The insulation seals are opened and exposed when the profile of conduit **742** activates the locking mechanisms.

[1153] Pins **786** secure locking mechanisms **780**, seals **790**, conduit **742**, and conduit **764** in place. In certain embodiments, pins **786** unlock the assembly after a selected temperature to allow movement (travel) of the conduits. For example, pins **786** may be made of materials that thermally degrade (for example, melt) above a desired temperature.

[1154] In some embodiments, locking mechanisms **780** are set in place using soft metal seals (for example, soft metal friction seals commonly used to set rod pumps in thermal wells). FIG. **160** depicts an embodiment with locking mechanisms **780** set in place using soft metal seals **788**. Soft metal seals **788** work by collapsing against a reduction in the inner diameter of conduit **742**. Using metal seals may increase the lifetime of the assembly versus using elastomeric seals.

[1155] In certain embodiments, lift systems are coupled to the piping of a heater that extends out of the formation. The lift systems may lift portions of the heater out of the formation to accommodate thermal expansion. FIG. **161** depicts a representation of u-shaped wellbore **490** with heater **412** positioned in the wellbore. Wellbore **490** may include casings **398** and lower seals **792**. Heater **412** may include insulated portions **794** with heater portion **796** adjacent to treatment area **730**. Moving seals **790** may be coupled to an upper portion of heater **412**. Lifting systems **798** may be coupled to insulated portions **794** above wellheads **392**. A non-reactive gas (for example, nitrogen and/or carbon dioxide) may be introduced in subsurface annular region **800** between casings **398** and insulated portions **794** to inhibit gaseous formation fluid from rising to wellhead **392** and to provide an insulating gas blanket. Insulated portions **794** may be conduit-in-conduits with the heat transfer fluid of the circulation system flowing through the inner conduit. The outer conduit of each insulated portion **794** may be at a substantially lower temperature than the inner conduit. The lower temperature of the outer conduit allows the outer conduits to be used as load bearing members for lifting heater **412**. Differential expansion between the outer conduit and the inner conduit may be mitigated by internal bellows and/or by sliding seals.

[1156] Lifting systems **798** may include hydraulic lifters, powered coiled tubing rigs, and/or counterweight systems capable of supporting heater **412** and moving insulated portions **794** into or out of the formation. When lifting systems **798** include hydraulic lifters, the outer conduits of insulated portions **794** may be kept cool at the hydraulic lifters by dedicated slick transition joints. The hydraulic lifters may include two sets of slips. A first set of slips may be coupled to the heater. The hydraulic lifters may maintain a constant pressure against the heater for the full stroke of the hydraulic cylinder. A second set of slips may periodically be set against the outer conduit while the stroke of the hydraulic cylinder is reset. Lifting systems **798** may also include strain gauges and control systems. The strain gauges may be attached to the outer conduit of insulated portions **794**, or the strain gauges may be attached to the inner conduits of the insulated portions below the insulation. Attaching the strain gauges to the outer conduit may be easier and the attachment coupling may be more reliable.

[1157] Before heating begins, set points for the control systems may be established by using lifting systems **798** to lift

heater **412** such that portions of the heater contact casing **398** in the bend portions of wellbore **490**. The strain when heater **412** is lifted may be used as the set point for the control system. In other embodiments, the set point is chosen in a different manner. When heating begins, heater portion **796** will begin expanding and some of the heater section will advance horizontally. If the expansion forces portions of heater **412** against casing **398**, the weight of the heater will be supported at the contact points of insulated portions **794** and the casing. The strain measured by lifting system **798** will go towards zero. Additional thermal expansion may cause heater **412** to buckle and fail. Instead of allowing heater **412** to press against casing **398**, hydraulic lifters of lifting systems **798** may move sections of insulated portions **794** upwards and out of the formation to keep the heater against the top of the casing. The control systems of lifting systems **798** may lift heater **412** to maintain the strain measured by the strain gauges near the set point value. Lifting system **798** may also be used to reintroduce insulated portions **794** into the formation when the formation cools to avoid damage to heater **412** during thermal contraction.

[1158] In certain embodiments, thermal expansion of the heater is completed in a relatively short time frame. In some embodiments, the position of the heater is fixed relative to the wellbore after thermal expansion is completed. The lifting systems may be removed from the heaters and used on other heaters that have not yet been heated. Lifting systems may be reattached to the heaters when the formation is cooled to accommodate thermal contraction of the heaters.

[1159] In some embodiments, the lifting systems are controlled based on the hydraulic pressure of the lifters. Changes in the tension of the pipe may result in a change in the hydraulic pressure. The control system may maintain the hydraulic pressure substantially at a set hydraulic pressure to provide accommodation of thermal expansion of the heater in the formation.

[1160] In certain embodiments, the circulation system uses a liquid to heat the formation. The use of liquid heat transfer fluid may allow for high overall energy efficiency for the system as compared to electrical heating or gas heaters due to the high energy efficiency of heat supplies used to heat the liquid heat transfer fluid. If furnaces are used to heat the liquid heat transfer fluid, the carbon dioxide footprint of the process may be reduced as compared to electrically heating or using gas burners positioned in wellbores due to the efficiencies of the furnaces. If nuclear power is used to heat the liquid heat transfer fluid, the carbon dioxide footprint of the process may be significantly reduced or even eliminated. The surface facilities for the heating system may be formed from commonly available industrial equipment in simple layouts. Using commonly available equipment in simple layouts may increase the overall reliability of the system.

[1161] In certain embodiments, the liquid heat transfer fluid is a molten salt or other liquid that has the potential to solidify if the temperature is below a selected temperature. A secondary heating system may be needed to ensure that heat transfer fluid remains in liquid form and that the heat transfer fluid is at a temperature that allows the heat transfer fluid to flow through the heaters from the circulation system. In certain embodiments, the secondary heating system heats the heater and/or the heat transfer fluid to a temperature that is sufficient to melt and ensure flowability of the heat transfer fluid instead of heating to a higher temperature. The secondary heating system may only be needed for a short period of

time during startup and/or re-startup of the fluid circulation system. In some embodiments, the secondary heating system is removable from the heater. In some embodiments, the secondary heating system does not have an expected lifetime on the order of the life of the heater.

[1162] In certain embodiments, molten salt is used as the heat transfer fluid. Insulated return storage tanks receive return molten salt from the formation. Temperatures in the return storage tanks may be, for example, in the vicinity of about 350° C. Pumps may move the molten salt from the return storage tanks to furnaces. Each of the pumps may need to move between 4 kg/s and 30 kg/s of the molten salt. Each furnace may provide heat to the molten salt. Exit temperatures of the molten salt from the furnaces may be about 550° C. The molten salt may pass from the furnaces to insulated feed storage tanks through piping. Each feed storage tank may supply molten salt to, for example, 50 or more piping systems that enter into the formation. The molten salt flows through the formation and to the return storage tanks. In certain embodiments, the furnaces have efficiencies that are 90% or greater. In certain embodiments, heat loss to the overburden is 8% or less.

[1163] In some embodiments, the heaters for the circulation systems include insulation along the lengths of the heaters, including portions of the heaters that are used to heat the treatment area. The insulation may facilitate insertion of the heaters into the formation. The insulation adjacent to portions used to heat the treatment area may be sufficient to provide insulation during preheating, but may decompose at temperatures produced by steady state circulation of the heat transfer fluid. In some embodiments, the insulation layer changes the emissivity of the heater to inhibit radiative heat transfer from the heater. After decomposition of the insulation, the emissivity of the heater may promote radiative heat transfer to the treatment area. The insulation may reduce the time needed to raise the temperature of the heaters and/or the heat transfer fluid in the heaters to temperatures sufficient to ensure melt and flowability of the heat transfer fluid. In some embodiments, the insulation adjacent to portions of the heaters that will heat the treatment area may include polymer coatings. In certain embodiments, insulation of portions of the heaters adjacent to the overburden is different than the insulation of the heaters adjacent to the portions of the heaters used to heat the treatment area. The insulation of the heaters adjacent to the overburden may have an expected lifetime equal to or greater than the lifetime of the heaters.

[1164] In some embodiments, degradable insulation material (for example, a polymer foam) may be introduced into the wellbore after or during placement of the heater. The degradable insulation may provide insulation adjacent to the portions of the heaters used to heat the treatment area during preheating. The liquid heat transfer fluid used to heat the treatment area may raise the temperature of the heater sufficiently enough to degrade and eliminate the insulation layer.

[1165] In some embodiments, the secondary heating system may electrically heat the heaters of the fluid circulation system. In some embodiments, electricity is applied directly to the heat transfer fluid conduit to resistively heat the heat transfer fluid conduit. Directly heating the heat transfer fluid conduit may require large current because of the relatively low resistance of the heat transfer fluid conduit. In some embodiments, a return current path is needed for the heat transfer fluid conduit.

[1166] In some embodiments, the heat transfer fluid conduit includes ferromagnetic material that allows the effective resistance of the heat transfer fluid conduit to be higher due to skin effect heating when time-varying current is applied to the heat transfer fluid conduit. For example, the heat transfer fluid conduit may be a steel with between about 9% and about 13% by weight chromium (for example, as 410 stainless steel). A return current path may be needed for the ferromagnetic material.

[1167] In certain embodiments, resistively heating the heater requires special considerations. Wellheads may need to include isolation flanges to ensure that current travels down the subsurface conduits and not through the surface pipe manifolds. Also, casings in the formation may need to be made of a non-ferromagnetic material (for example, non-ferromagnetic high manganese content steel, fiberglass, or carbon fiber) to inhibit induction current heating of the casing and/or the surrounding formation. In some embodiments, the overburden section of the heater is a conduit-in-conduit configuration with a thermal barrier between the conduits. The thermal barrier may act as insulation to limit the amount of heat transferred to the inner conduit and the molten salt. Making the outer conduit of a non-ferromagnetic material may allow for distribution of current between the inner conduit and the outer conduit to adequately heat the inner conduit and salt. In some embodiments, electrically conductive centralizers are located between the casing and the heater.

[1168] FIG. 162 depicts a side view representation of an embodiment of a system for heating a portion of a formation using a circulated fluid system and/or electrical heating. Wellheads 392 of heaters 412 may be coupled to heat transfer fluid circulation system 706 by piping. Wellheads 392 may also be coupled to electrical power supply system 802. In some embodiments, heat transfer fluid circulation system 706 is disconnected from the heaters when electrical power is used to heat the formation. In some embodiments, electrical power supply system 802 is disconnected from the heaters when heat transfer fluid circulation system 706 is used to heat the formation.

[1169] Electrical power supply system 802 may include transformer 414 and cables 804, 806. In certain embodiments, cables 804, 806 are capable of carrying high currents with low losses. For example, cables 804, 806 may be thick copper or aluminum conductors. The cables may also have thick insulation layers. In some embodiments, cable 804 and/or cable 806 may be superconducting cables. The superconducting cables may be cooled by liquid nitrogen. Superconducting cables are available from Superpower, Inc. (Schenectady, N.Y., U.S.A.). Superconducting cables may minimize power loss and/or reduce the size of the cables needed to couple transformer 414 to the heaters. In some embodiments, cables 804, 806 are made of carbon nanotubes. Cables 804, 806 may be electrically coupled to heaters 412 to resistively heat the heaters.

[1170] In some embodiments, insulated conductors that resistively heat are used to preheat and/or ensure heat transfer flow in the heaters of a fluid circulation system. FIG. 163 depicts a representation of heater 412 that may initially be resistively heated with the return current path provided by insulated conductor 410. Electrical connection between a lead of transformer 414 and heater 412 may be made near a first side of the heater. The other lead of transformer 414 may be electrically coupled to insulated conductor 410. Electrical connection 808 between heater 412 and insulated conductor

410 may be made on an opposite side of heater from transformer **414** to complete the electrical circuit. FIG. **164** depicts a representation of heater **412** that may initially be resistively heated with the return current path provided by two insulated conductors **410**. Transformers **414** may be located on each side of heater **412**. Leads from transformers **414** may be electrically coupled to heater **412**. The other leads for transformers **414** may be electrically coupled to insulated conductors **410**. Electrical connections **808** between insulated conductors **410** and heater **412** may be made near the center of the heater to complete the electrical circuits. Insulated conductors **410** depicted in FIG. **163** and FIG. **164** may be good electrical conductors that provide little or no resistive heating. Insulated conductors **410** may be coupled to the inside of heaters **412** as depicted, or the insulated conductors may be positioned outside of the heaters.

[**1171**] FIG. **165** depicts a representation of insulated conductors **410** used to resistively heat heaters **412** of a circulated fluid heating system. Insulated conductors **410** may be coupled to transformer **414** in a three phase configuration. Lead-in and lead-out portions of insulated conductors may be good electrical conductors that provide little or no resistive heating. Portions of insulated conductors **410** coupled to or positioned in heaters **412** may include material that resistively heats to temperatures sufficient to heat the heat transfer fluid in the heaters to a temperature sufficient to allow flow of the heat transfer fluid. In some embodiments, the material is ferromagnetic and the insulated conductors operate as temperature limited heaters. The Curie point temperature limit or phase transition temperature limit of the ferromagnetic material may allow the insulated conductors to reach temperatures above but relatively close to the temperature needed to ensure melt and flowability of heat transfer fluid in heaters **412**.

[**1172**] FIG. **166** depicts insulated conductor **410** positioned in heater **412**. Heater **412** is piping of the circulation system positioned in the formation. Electricity applied to insulated conductor **410** resistively heats the insulated conductor. The generated heat transfers to heater **412** and heat transfer fluid in the heater. In some embodiments, the insulated conductors may be strapped to the outside of the heaters instead of being placed inside of the heaters. Insulated conductor **410** may be a relatively thin mineral insulated conductor positioned in a relatively large diameter piping as shown. In some embodiments, insulated conductors positioned in the heaters may be placed inside of a protective sleeve. For example, the insulated conductor may have an outer diameter of about 0.6 inches and placed inside a 1 inch tube or pipe that is placed in the 5 inch heater pipe.

[**1173**] In some embodiments, insulated conductors positioned inside or outside heaters used with a circulated fluid heating system may provide current that is used to cause inductive heating. The current flowing through the insulated conductors may be used to induce currents in the heater so that the heater resistively heats. In some embodiments, the insulated conductors may be wrapped with a coil that is inductively heated. The coil may be made of a material that has a Curie temperature limit or phase transition temperature limit slightly higher than the temperature needed to ensure melt and flowability of heat transfer fluid in the heaters.

[**1174**] In some embodiments, insulated conductors used as current paths or as electrical heaters may be removable from heaters used for circulating heat transfer fluid. After heat transfer fluid circulation in a heater is initiated and stabilizes, the heat transfer fluid will heat the adjacent formation to

temperatures above the temperature needed to ensure melt and flowability of the heat transfer fluid. The heat of the formation and the heat of the heat transfer fluid may be sufficient to ensure melt and flowability of the heat transfer fluid should the circulation system temporarily be interrupted (for example, for a day, a week, or a month). For heaters with the insulated conductor positioned in the heater, the insulated conductors may be pulled out of the heater through seals in the wellhead that allow for electrical connection to the insulated conductors. The insulated conductors may be coiled and reused in heaters that have not been preheated. Should it be necessary, insulated conductor heaters may be reintroduced into the heaters.

[**1175**] In some embodiments of circulation systems that use molten salt or another liquid as the heat transfer fluid, the heater may be a single conduit in the formation. The conduit may be preheated to a temperature sufficient to ensure flowability of the heat transfer fluid. In some embodiments, a secondary heat transfer fluid is circulated through the conduit to preheat the conduit and/or the formation adjacent to the conduit. After the temperature of the conduit and/or the formation adjacent to the conduit is sufficiently hot, the secondary fluid may be flushed from the conduit and the heat transfer fluid may be circulated through the pipe.

[**1176**] In some embodiments, aqueous solutions of the salt composition (for example, Li:Na:K:NO₃) that is to be used as the heat transfer fluid are used to preheat the conduit. A temperature of the secondary heat transfer fluid may be below or equal to a temperature of a subsurface outlet of the wellhead.

[**1177**] In some embodiments, the secondary heat transfer fluid (for example, water) is heated to a temperature ranging from 0° C. to about 95° C. or up to the boiling point of the secondary heat transfer fluid. The salt composition may be added to the secondary heat transfer fluid while in a storage tank of the circulation systems. The composition of the salt and/or the pressure of the system may be adjusted to inhibit boiling of the aqueous solution as the temperature is increased. When the conduit is preheated to a temperature sufficient to ensure flowability of the molten salt, the remaining water may be removed from the aqueous solution to leave only the molten salt. The water may be removed by evaporation while the salt solution is in a storage tank of the circulation system. In some embodiments, the temperature of the molten salt solution is raised to above 100° C. When the conduit is preheated to a temperature sufficient to ensure flowability of the molten salt, substantially or all of the remaining secondary heat transfer fluid (for example, water) may be removed from the salt solution to leave only the molten salt. In some embodiments, the temperature of the molten salt solution during the evaporation process ranges from 100° C. to 250° C.

[**1178**] Upon completion of the in situ heat treatment process, the molten salt may be cooled and water added (for example, water may be sprayed into the storage tank) to the salt to form another aqueous solution. In some embodiments, the molten salt may be cooled by circulating the molten salt solution through one or more heat exchangers. The aqueous solution may be transferred to another treatment area and the process continued. In some embodiments, sufficient water may be added and circulated to the storage system until the molten salt solution is below the required level for abandonment. The excess water solution may be transferred to another tank for disposal and/or transferred to another treatment area.

Use of tertiary molten salts as aqueous solutions facilitates transportation of the solution and allows than one section of a formation to be treated with the same salt.

[1179] In some embodiments of circulation systems that use molten salt or other liquid as the heat transfer fluid, the heater may have a conduit-in-conduit configuration. The liquid heat transfer fluid used to heat the formation may flow through a first passageway through the heater. A secondary heat transfer fluid may flow through a second passageway through the conduit-in-conduit heater for preheating and/or for flow assurance of the liquid heat transfer fluid. After the heater is raised to a temperature sufficient to ensure continued flow of heat transfer fluid through the heater, a vacuum may be drawn on the passageway for the secondary heat transfer fluid to inhibit heat transfer from the first passageway to the second passageway. In some embodiments, the passageway for the secondary heat transfer fluid is filled with insulating material and/or is otherwise blocked. The passageways in the conduit of the conduit-in-conduit heater may include the inner conduit and the annular region between the inner conduit and the outer conduit. In some embodiments, one or more flow switchers are used to change the flow in the conduit-in-conduit heater from the inner conduit to the annular region and/or vice versa.

[1180] FIG. 167 depicts a cross-sectional view of an embodiment of conduit-in-conduit heater 412 for a heat transfer circulation heating system adjacent to treatment area 730. Heater 412 may be positioned in wellbore 490. Heater 412 may include outer conduit 810 and inner conduit 812. During normal operation of heater 412, liquid heat transfer fluid may flow through annular region 814 between outer conduit 810 and inner conduit 812. During normal operation, fluid flow through inner conduit 812 may not be needed.

[1181] During preheating and/or for flow assurance, a secondary heat transfer fluid may flow through inner conduit 812. The secondary fluid may be, but is not limited to, air, carbon dioxide, exhaust gas, and/or a natural or synthetic oil (for example, DowTherm A, Syltherm, or Therminol 59), room temperature molten salts (for example, $\text{NaCl}_2\text{—SrCl}_2$, VCl_4 , SnCl_4 , or TiCl_4), high pressure liquid water, steam, or room temperature molten metal alloys (for example, a K—Na eutectic or a Ga—In—Sn eutectic). In some embodiments, outer conduit 810 is heated by the secondary heat transfer fluid flowing through annular region 814 (for example, carbon dioxide or exhaust gas) before the heat transfer fluid that is used to heat the formation is introduced into the annular region. If exhaust gas or other high temperature fluid is used, another heat transfer fluid (for example, water or steam) may be passed through the heater to reduce the temperature below the upper working temperature limit of the liquid heat transfer fluid. The secondary heat transfer fluid may be displaced from the annular region when the liquid heat transfer fluid is introduced into the heater. The secondary heat transfer fluid in inner conduit 812 may be the same fluid or a different fluid than the secondary fluid used to preheat outer conduit 810 during preheating. Using two different secondary heat transfer fluids may help in the identification of integrity problems in heater 412. Any integrity problems may be identified and fixed before the use of the molten salt is initiated.

[1182] In some embodiments, the secondary heat transfer fluid that flows through annular region 814 during preheating is an aqueous mixture of the salt to be used during normal operation. The salt concentration may be increased periodically to increase temperature while remaining below the boil-

ing temperature of the aqueous mixture. The aqueous mixture may be used to raise the temperature of outer conduit 810 to a temperature sufficient to allow the molten salt to flow in annular region 814. When the temperature is reached, the remaining water in the aqueous mixture may evaporate out of the mixture to leave the molten salt. The molten salt may be used to heat treatment area 730.

[1183] In some embodiments, inner conduit 812 may be made of a relatively inexpensive material such as carbon steel. In some embodiments, inner conduit 812 is made of material that survives through an initial early stage of the heat treatment process. Outer conduit 810 may be made of material resistant to corrosion by the molten salt and formation fluid (for example, P91 steel).

[1184] For a given mass flow rate of liquid heat transfer fluid, heating the treatment area using liquid heat transfer fluid flowing in annular region 814 between outer conduit 810 and inner conduit 812 may have certain advantages over flowing the liquid heat transfer fluid through a single conduit. Flowing secondary heat transfer fluid through inner conduit 812 may pre-heat heater 412 and ensure flow when liquid heat transfer fluid is first used and/or when flow needs to be restarted after a stop of circulation. The large outer surface area of outer conduit 810 provides a large surface area for heat transfer to the formation while the amount of liquid heat transfer fluid needed for the circulation system is reduced because of the presence of inner conduit 812. The circulated liquid heat transfer fluid may provide a better power injection rate distribution to the treatment area due to increased velocity of the liquid heat transfer fluid for the same mass flow rate. Reliability of the heater may also be improved.

[1185] In some embodiments, the heat transfer fluid (molten salt) may thicken and flow of the heat transfer fluid through outer conduit 810 and/or inner conduit 812 is slowed and/or impaired. Selectively heating various portions of inner conduit 812 may provide sufficient heat to various parts of the heater 412 to increase flow of the heat transfer fluid through the heater. Portions of heater 412 may include ferromagnetic material (for example, insulated conductors) to allow current to be passed along selected portions of the heater. Resistively heating inner conduit 812 transfers sufficient heat to thickened heat transfer fluid in outer conduit 810 and/or inner conduit 812 to lower the viscosity of the heat transfer fluid such that increased flow, as compared to flow prior to heating of the molten salt, through the conduits is obtained. Using time-varying current allows current to be passed along the inner conduit without passing current through the heat transfer fluid.

[1186] FIG. 168 depicts a schematic for heating various portions of heater 412 to restart flow of thickened or immobilized heat transfer fluid (for example, a molten salt) in the heater. In certain embodiments, portions of inner conduit 812 and/or outer conduit 810 include ferromagnetic materials surrounded by thermal insulation. Thus, these portions of inner conduit 812 and/or outer conduit 810 may be insulated conductors 410. Insulated conductors 410 may operate as temperature limited heaters or skin-effect heaters. Because of the skin-effect of insulated conductors 410, electrical current provided to the insulated conductors remains confined to inner conduit 812 and/or outer conduit 810 and does not flow through the heat transfer fluid located in the conduits.

[1187] In certain embodiments, insulated conductors 410 are positioned along a selected length of inner conduit 812 (for example, the entire length of the inner conduit or only the

overburden portion of the inner conduit). Applying electricity to inner conduit **812** generates heat in insulated conductors **410**. The generated heat may heat thickened or immobilized heat transfer fluid along the selected length of the inner conduit. The generated heat may heat the heat transfer fluid both inside the inner conduit and in the annulus between the inner conduit and outer conduit **810**. In certain embodiments, inner conduit **812** only includes insulated conductors **410** positioned in the overburden portion of the inner conduit. These insulated conductors selectively generate heat in the overburden portions of inner conduit **812**. Selectively heating the overburden portion of inner conduit **812** may transfer heat to thickened heat transfer fluid and restart flow in the overburden portion of the inner conduit. Such selective heating may increase heater life and minimize electrical heating costs by concentrating heat in the region most likely to encounter thickening or immobilization of the heat transfer fluid.

[1188] In certain embodiments, insulated conductors **410** are positioned along a selected length of outer conduit **810** (for example, the overburden portion of the outer conduit). Applying electricity to outer conduit **810** generates heat in insulated conductors **410**. The generated heat may selectively heat the overburden portions of the annulus between inner conduit **812** and outer conduit **810**. Sufficient heat may be transferred from outer conduit **810** to lower the viscosity of the thickened heat transfer fluid to allow unimpaired flow of the molten salt in the annulus.

[1189] In certain embodiments, having a conduit-in-conduit heater configuration allows flow switchers to be used that change the flow of heat transfer fluid in the heater from flow through the annular region between the outer conduit and the inner conduit, when flow is adjacent to the treatment area, to flow through the inner conduit, when flow is adjacent to the overburden. FIG. 169 depicts a schematic representation of conduit-in-conduit heaters **412** that are used with fluid circulation systems **706**, **706'** to heat treatment area **730**. In certain embodiments, heaters **412** include outer conduit **810**, inner conduit **812**, and flow switchers **816**. Fluid circulation systems **706**, **706'** provide heated liquid heat transfer fluid to wellheads **392**. The direction of flow of liquid heat transfer fluid is indicated by arrows **818**.

[1190] Heat transfer fluid from fluid circulation system **706** passes through wellhead **392** to inner conduit **812**. The heat transfer fluid passes through flow switcher **816**, which changes the flow from inner conduit **812** to the annular region between outer conduit **810** and the inner conduit. The heat transfer fluid then flows through heater **412** in treatment area **730**. Heat transfer from the heat transfer fluid provides heat to treatment area **730**. The heat transfer fluid then passes through second flow switcher **816'**, which changes the flow from the annular region back to inner conduit **812**. The heat transfer fluid is removed from the formation through second wellhead **392'** and is provided to fluid circulation system **706'**. Heated heat transfer fluid from fluid circulation system **706'** passes through heater **412'** back to fluid circulation system **706**.

[1191] Using flow switchers **816** to pass the fluid through the annular region while the fluid is adjacent to treatment area **730** promotes increased heat transfer to the treatment area due in part to the large heat transfer area of outer conduit **810**. Using flow switchers **816** to pass the fluid through the inner conduit when adjacent to overburden **400** may reduce heat

losses to the overburden. Additionally, heaters **412** may be insulated adjacent to overburden **400** to reduce heat losses to the formation.

[1192] FIG. 170 depicts a cross-sectional view of an embodiment of a conduit-in-conduit heater **412** adjacent to overburden **400**. Insulation **820** may be positioned between outer conduit **810** and inner conduit **812**. Liquid heat transfer fluid may flow through the center of inner conduit **812**. Insulation **820** may be a highly porous insulation layer that inhibits radiation at high temperatures (for example, temperatures above 500° C.) and allows flow of a secondary heat transfer fluid during preheating and/or flow assurance stages of heating. During normal operation, flow of fluid through the annular region between outer conduit **810** and inner conduit **812** adjacent to overburden **400** may be stopped or inhibited.

[1193] Insulating sleeve **722** may be positioned around outer conduit **810**. Insulating sleeves **722** on each side of a u-shaped heater may be securely coupled to outer conduit **810** over a long length when the system is not heated so that the insulating sleeves on each side of the u-shaped wellbore are able to support the weight of the heater. Insulating sleeve **722** may include an outer member that is a structural member that allows heater **412** to be lifted to accommodate thermal expansion of the heater. Casing **398** may surround insulating sleeve **722**. Insulating cement **740** may couple casing **398** to overburden **400**. Insulating cement **740** may be a low thermal conductivity cement that reduces conductive heat losses. For example, insulating cement **740** may be a vermiculite/cement aggregate. A non-reactive gas may be introduced into gap **744** between insulating sleeve **722** and casing **398** to inhibit formation fluid from rising in the wellbore and/or to provide an insulating gas blanket.

[1194] FIG. 171 depicts a schematic of an embodiment of circulation system **706** that supplies liquid heat transfer fluid to conduit-in-conduit heaters positioned in the formation (for example, the heaters depicted in FIG. 169). Circulation system **706** may include heat supply **708**, compressor **822**, heat exchanger **824**, exhaust system **826**, liquid storage tank **828**, fluid movers **714** (for example, pumps), supply manifold **830**, return manifold **832**, and secondary heat transfer fluid circulation system **834**. In certain embodiments, heat supply **708** is a furnace. Fuel for heat supply **708** may be supplied through fuel line **836**. Control valve **838** may regulate the amount of fuel supplied to heat supply **708** based on the temperature of hot heat transfer fluid as measured by temperature monitor **840**.

[1195] Oxidant for heat supply **708** may be supplied through oxidant line **842**. Exhaust from heat supply **708** may pass through heat exchanger **824** to exhaust system **826**. Oxidant from compressor **822** may pass through heat exchanger **824** to be heated by the exhaust from heat supply **708**.

[1196] In some embodiments, valve **844** may be opened during preheating and/or during start-up of fluid circulation to the heaters to supply secondary heat transfer fluid circulation system **834** with a heating fluid. In some embodiments, exhaust gas is circulated through the heaters by secondary heat transfer fluid circulation system **834**. In some embodiments, the exhaust gas passes through one or more heat exchangers of secondary heat transfer fluid circulation system **834** to heat fluid that is circulated through the heaters.

[1197] During preheating, secondary heat transfer fluid circulation system **834** may supply secondary heat transfer fluid to the inner conduit of the heaters and/or to the annular region

between the inner conduit and the outer conduit. Line **846** may provide secondary heat transfer fluid to the part of supply manifold **830** that supplies fluid to the inner conduits of the heaters. Line **848** may provide secondary heat transfer fluid to the part of supply manifold **830** that supplies fluid to the annular regions between the inner conduits and the outer conduits of the heaters. Line **850** may return secondary heat transfer fluid from the part of the return manifold **832** that returns fluid from the inner conduits of the heaters. Line **852** may return secondary heat transfer fluid from the part of the return manifold **832** that returns fluid from the annular regions of the heaters. Valves **854** of secondary heat transfer fluid circulation system **834** may allow or stop secondary heat transfer flow to or from supply manifold **830** and/or return manifold **832**. During preheating, all valves **854** may be open. During the flow assurance stage of heating, valves **854** for line **846** and for line **850** may be closed, and valves **854** for line **848** and line **852** may be open. Liquid heat transfer fluid from heat supply **708** may be provided to the part of supply manifold **830** that supplies fluid to the inner conduits of the heaters during the flow assurance stage of heating. Liquid heat transfer fluid may return to liquid storage tank **828** from the portion of return manifold **832** that returns fluid from the inner conduits of the heaters. During normal operation, all valves **854** may be closed.

[1198] In some embodiments, secondary heat transfer fluid circulation system **834** is a mobile system. Once normal flow of heat transfer fluid through the heaters is established, the mobile secondary heat transfer fluid circulation system **834** may be moved and attached to another circulation system that has not been initiated.

[1199] During normal operation, liquid storage tank **828** may receive heat transfer fluid from return manifold **832**. Liquid storage tank **828** may be insulated and heat traced. Heat tracing may include steam circulation system **856** that circulates steam through coils in liquid storage tank **828**. Steam passed through the coils maintains heat transfer fluid in liquid storage tank **828** at a desired temperature or in a desired temperature range.

[1200] Fluid movers **714** may move liquid heat transfer fluid from liquid storage tank **828** to heat supply **708**. In some embodiments, fluid movers **714** are submersible pumps that are positioned in liquid storage tank **828**. Having fluid movers **714** in storage tanks may keep the pumps at temperatures well within the operating temperature limits of the pumps. Also, the heat transfer fluid may function as a lubricant for the pumps. One or more redundant pump systems may be placed in liquid storage tank **828**. A redundant pump system may be used if the primary pump system shuts down or needs to be serviced.

[1201] During start-up of heat supply **708**, valves **858** may direct liquid heat transfer fluid to liquid storage tank. After preheating of a heater in the formation is completed, valves **858** may be reconfigured to direct liquid heat transfer fluid to the part of supply manifold **830** that supplies the liquid heat transfer fluid to the inner conduit of the preheated heater. Return liquid heat transfer fluid from the inner conduit of a preheated return conduit may pass through the part of return manifold **832** that receives heat transfer fluid that has passed through the formation and directs the heat transfer fluid to liquid storage tank **828**.

[1202] To begin using fluid circulation system **706**, liquid storage tank **828** may be heated using steam circulation system **856**. The heat transfer fluid may be added to liquid stor-

age tank **828**. The heat transfer fluid may be added as solid particles that melt in liquid storage tank **828** or liquid heat transfer fluid may be added to the liquid storage tank. Heat supply **708** may be started, and fluid movers **714** may be used to circulate heat transfer fluid from liquid storage tank **828** to the heat supply and back. Secondary heat transfer fluid circulation system **834** may be used to heat heaters in the formation that are coupled to supply manifolds **830** and return manifolds **832**. Supply of secondary heat transfer fluid to the portion of supply manifold **830** that feeds the inner conduits of the heaters may be stopped. The return of secondary heat transfer fluid from the portion of return manifold that receives heat transfer fluid from the inner conduits of the heaters may also be stopped. Heat transfer fluid from heat supply **708** may then be directed to the inner conduit of the heaters.

[1203] The heat transfer fluid may flow through the inner conduits of the heaters to flow switchers that change the flow of fluid from the inner conduits to the annular regions between the inner conduits and the outer conduits. The heat transfer fluid may then pass through flow switchers that change the flow back to the inner conduits. Valves coupled to the heaters may allow heat transfer fluid flow to the individual heaters to be started sequentially instead of having the fluid circulation system supply heat transfer fluid to all of the heaters at once.

[1204] Return manifold **832** receives heat transfer fluid that has passed through heaters in the formation that are supplied from a second fluid circulation system. Heat transfer fluid in return manifold **832** may be directed back into liquid storage tank **828**.

[1205] During initial heating, secondary heat transfer fluid circulation system **834** may continue to circulate secondary heat transfer fluid through the portion of the heater not receiving the heat transfer fluid supplied from heat supply **708**. In some embodiments, secondary heat transfer fluid circulation system **834** directs the secondary heat transfer fluid in the same direction as the flow of heat transfer fluid supplied from heat supply **708**. In some embodiments, secondary heat transfer fluid circulation system **834** directs the secondary heat transfer fluid in the opposite direction to the flow of heat transfer fluid supplied from heat supply **708**. The secondary heat transfer fluid may ensure continued flow of the heat transfer fluid supplied from heat supply **708**. Flow of the secondary heat transfer fluid may be stopped when the secondary heat transfer fluid leaving the formation is hotter than the secondary heat transfer fluid supplied to the formation due to heat transfer with the heat transfer fluid supplied from heat supply **708**. In some embodiments, flow of secondary heat transfer fluid may be stopped when other conditions are met, after a selected period of time.

[1206] FIG. 172 depicts a schematic representation of a system for providing and removing liquid heat transfer fluid to the treatment area of a formation using gravity and gas lifting as the driving forces for moving the liquid heat transfer fluid. The liquid heat transfer fluid may be a molten metal or a molten salt. Vessel **860** is elevated above heat exchanger **862**. Heat transfer fluid from vessel **860** flows through heat transfer unit **862** to the formation by gravity drainage. In an embodiment, heat exchanger **862** is a tube and shell heat exchanger. Input stream **864** is a hot fluid (for example, helium) from nuclear reactor **866**. Exit stream fluid **868** may be sent as a coolant stream to nuclear reactor **866**. In some embodiments, the heat exchanger is a furnace, solar collector,

chemical reactor, fuel cell, and/or other high temperature source able to supply heat to the liquid heat transfer fluid.

[1207] Hot heat transfer fluid from heat exchanger 862 may pass to a manifold that provides heat transfer fluid to individual heater legs positioned in the treatment area of the formation. The heat transfer fluid may pass to the heater legs by gravity drainage. The heat transfer fluid may pass through overburden 400 to hydrocarbon containing layer 388 of the treatment area. The piping adjacent to overburden 400 may be insulated. Heat transfer fluid flows downwards to sump 870.

[1208] Gas lift piping may include gas supply line 872 within conduit 874. Gas supply line 872 may enter sump 870. When lift chamber 876 in sump 870 fills to a selected level with heat transfer fluid, a gas lift control system operates valves of the gas lift system to lift the heat transfer fluid through the space between gas supply line 872 and conduit 874 to separator 878. Separator 878 may receive heat transfer fluid and lifting gas from a piping manifold that transports the heat transfer fluid and lifting gas from the individual heater legs in the formation. Separator 878 separates the lift gas from the heat transfer fluid. The heat transfer fluid is sent to vessel 860.

[1209] Conduits 874 from sumps 870 to separator 878 may include one or more insulated conductors or other types of heaters. The insulated conductors or other types of heaters may be placed in conduits 874 and/or be strapped or otherwise coupled to the outside of the conduits. The heaters may inhibit densification or solidification of the heat transfer fluid in conduits 874 during gas lift from sump 870.

[1210] A portion of the heat input into a treatment area using circulated heat transfer fluid may be recovered after the in situ heat treatment process is completed. Initially, the same heat transfer fluid used to heat the treatment area may be circulated through the formation without the heat source reheating the heat transfer fluid such that the heat transfer fluid absorbs heat from the treatment area. The heat transfer fluid heated by the treatment area may be circulated through an adjacent unheated treatment area to begin heating the unheated treatment area. In some embodiments, the heat transfer fluid heated by the treatment area passes through a heat exchanger to heat a second heat transfer fluid that is used to begin heating the unheated treatment area.

[1211] In some embodiments, a different heat transfer fluid than the heat transfer fluid used to heat the treatment area may be used to recover heat from the formation. A different heat transfer fluid may be used when the heat transfer fluid used to heat the treatment area has the potential to solidify in the piping during recovery of heat from the treatment area. The different heat transfer fluid may be a low melting temperature salt or salt mixture, steam, carbon dioxide, or a synthetic oil (for example, DowTherm or Therminol).

[1212] In some embodiments, initial heating of the formation may be performed using circulated molten solar salt (NaNO_3 — KNO_3) flowing through conduits in the formation. Heating may be continued until fluid communication between heater wells and producer wells is established and a relatively large amount of coke develops around the heater wells. Circulation may be stopped and one or more of the conduits may be perforated. In an embodiment, the heater includes a perforated outer conduit and an inner liner that is chemically resistant to the heat transfer fluid. When heat transfer fluid is stopped, the liner may be withdrawn or chemically dissolved to allow fluid flow from the heater into the formation. In other embodiments, perforation guns may

be used in the piping after flow of circulated heat transfer fluid is stopped. Nitrate salts or other oxidizers may be introduced into the formation through the perforations. The nitrate salts or other oxidizers may oxidize the coke to finish heating the reservoir to desired temperatures. The concentration and amount of nitrate salts or other oxidizers introduced into the formation may be controlled to control the heating of the formation. Oxidizing the coke in the formation may heat the formation efficiently and reduce the time for heating the formation to a desired temperature. Oxidation product gases may convectively transfer heat in the formation and provide a gas drive that moves formation fluid towards the production wells.

[1213] In some embodiments, a subsurface hydrocarbon containing formation may be treated by the in situ heat treatment process to produce mobilized and/or pyrolyzed products from the formation. A significant amount of carbon in the form of coke and/or residual oil may remain in portions of the formation when production of fluids from the portions is completed. In some embodiments, the coke and/or residual oil in the portions may be utilized to produce heat and/or additional products from the formation.

[1214] In some embodiments, an oxidizing fluid (for example, air, oxygen enriched air, other oxidants) may be introduced into a treatment area that has been treated to react with the coke and/or residual oil in the portion. The temperature of the treatment area may be sufficiently hot to support burning of the coke and/or residual oil without additional energy input from heaters. In some embodiments, additional heat from heaters and/or other heat sources may be used to add additional energy to ensure continued combustion and/or initiate combustion of the coke and/or residual oil. In some embodiments, sufficient oxidizing fluid may be introduced into a wellbore such that the combustion process proceeds continuously. The oxidation of the coke and/or residual oil may significantly heat the treatment area. Some of the heat may transfer to portions of the formation adjacent to the treatment area. The transferred heat may mobilize and/or pyrolyze fluids in the portions of the formation adjacent to the treatment area. The mobilized and/or pyrolyzed fluids may flow to and be produced from production wells near the perimeter of the treatment area.

[1215] Products (for example, gases) produced from the formation heated by combusting coke and/or residual oil in the formation may be at high temperature. In some embodiments, the hot gases may be utilized in an energy recovery cycle (for example, a Kalina cycle or a Rankine cycle) to produce electricity.

[1216] In certain embodiments, thermal energy from the combustion products are collected and used for a variety of applications. Thermal energy may be used to generate electricity as previously mentioned. In some embodiments, however, collected thermal energy is used to heat a second portion of the formation for the purpose of conducting the in situ heat treatment process on the second portion of the formation. In some embodiments, thermal energy is used to heat a second formation substantially adjacent to the first formation.

[1217] In certain embodiment, thermal energy from the combustion products and regions heated by combustion is transferred directly to a heat transfer fluid. The thermal energy collected in this way may be used directly to heat a second portion of the formation for the purpose of conducting the in situ heat treatment process on the second portion of the

formation. In some embodiments, thermal energy is used to heat a second formation substantially adjacent to the first formation.

[1218] Recovering energy in the form of thermal energy from the formation (for example, a previously treated formation) may conserve energy and, thus, decrease overall production costs for hydrocarbon production from a particular formation. The energy collected from the combustion of coke and/or residual hydrocarbons may be greater than the energy required to combust the coke/residual hydrocarbons and collect the resulting thermal energy. For example, in a portion of a formation that has undergone in situ upgrading for eight years, energy that results from combustion of the coke/residual hydrocarbons may be about 1.4 times the energy that is required to combust the coke/residual hydrocarbons and collect the energy. Even with as much as 20% energy loss to the overburden during the process compounded with about a 15% efficiency of energy transfer to electricity, one may collect up to 17% of the energy required for treating the formation.

[1219] In certain embodiments, the quantity of energy recovered from the subsurface formation is considerable, as the data in TABLE 6 demonstrates. A formation that has undergone an in situ upgrading process and/or an in situ upgrading process heating cycle for 6 years may yield, upon combustion of the remaining hydrocarbons and coke, a net energy gain of 63% relative to the energy required for the heating cycle. A formation which has undergone an in situ upgrading process and/or an in situ upgrading process heating cycle for 8 years may yield, upon combustion of the remaining hydrocarbons and coke, a net energy gain of 29% relative to the energy required for the heating cycle. The net energy gain is lower for the formation having undergone an 8 year heating cycle for several reasons, as demonstrated in TABLE 6: the heat input required per pattern is greater than for a 6 year heating cycle; and, due to the longer heating cycle, there is considerably less residual hydrocarbons to combust for energy recovery relative to the 6 year heating cycle.

TABLE 6

Duration of heating (years)	6	8
Heat input required/pattern (10 ⁹ BTU)	3.2	3.9
Combustion: coke		
% of heat required	13	18
Combustion: residual hydrocarbons		
% of heat required	358	152
Total (% of heat required, assuming 50% recovery)	186	85
Energy required for air compression (% of heat required, assuming 50% excess air required, at 85% efficiency)	123	56
Net energy gain (% of heat required)	63	29

[1220] In some embodiments, a method for recovering energy from the subsurface hydrocarbon containing formation includes introducing the oxidizing fluid in at least a portion of the formation. The oxidizing fluid may be introduced into at least one wellbore positioned in the portion of the formation. The portion, or treatment area, of the formation may have been previously subjected to the in situ heat treatment process. The treatment area may include elevated levels of coke. In some embodiments, the treatment area is substantially adjacent or surrounding the wellbore.

[1221] The oxidizing fluid may be used to increase the pressure in the wellbore. Increasing the pressure in the wellbore may move the oxidizing fluid through at least a majority

of the treatment area. In some embodiments, increasing the pressure in the wellbore moves the oxidizing fluid past the treatment area such that the treatment area is substantially inundated with oxidizing fluid. Inundation with oxidizing fluid may increase the efficiency of the combustion process ensuring that a greater majority of the coke and/or residual oil in the treatment area is consumed during the combustion process. FIG. 173 depicts an end view representation of an embodiment of wellbore 490 in treatment area 730 undergoing a combustion process. In FIG. 173, oxidizing fluid 678 is being conveyed down wellbore 490 and through treatment area 730.

[1222] Upon initiating combustion in the treatment area and pressurizing the wellbore to help ensure the combustion process extends throughout the treatment area, the pressure in the wellbore may be decreased. Decreasing the pressure in the wellbore may draw heated fluids from the treatment area in the wellbore. Heated fluids drawn in the wellbore may be collected. Heated fluids may include heated gases such as unconsumed heated oxidizing fluids and/or heated combustion products. In some embodiments, heated fluids include heated liquid hydrocarbons. FIG. 174 depicts an end view representation of an embodiment of wellbore 490 in treatment area 730 undergoing fluid removal following the combustion process. In FIG. 174, heated fluids 880 are being drawn out of treatment area 730 through wellbore 490 during a depressurization cycle.

[1223] In some embodiments, the wellbore and/or the treatment area are allowed to rest between pressurization and depressurization cycles for a period of time. Such a "rest period" may increase the efficiency of the combustion process, for example, by allowing injected oxidizing fluids to be more fully consumed before the depressurization and extraction process begins.

[1224] In some embodiments, heated fluids drawn into the wellbore are conveyed to the surface of the formation. The heated fluids may be conveyed to a heat exchanger at the surface of the formation. The heat exchanger may function to collect thermal energy from the heated fluids. The heat exchanger may transfer thermal energy from the heated fluids collected from the formation to one or more heat transfer fluids. In some embodiments, the heat transfer fluid includes thermally conductive gases (for example, helium, steam, carbon dioxide). In certain embodiments, the heat transfer fluid includes molten salts, molten metals, and/or condensable hydrocarbons. Thermal energy collected by the heat transfer fluid may be used in any number of production and/or heating processes. Heated heat transfer fluid may be transferred to a second portion of the formation. The heat transfer fluid may be used to heat the second portion, for example, as part of the in situ conversion process. Heated heat transfer fluid may be transferred to a second formation substantially adjacent to the formation in order to heat a portion of the second formation.

[1225] In some embodiments, the heat transfer fluid is introduced into the wellbore such that heat is transferred from heated fluids in the wellbore to the heat transfer fluid. Thermal energy collected by the heat transfer fluid may be used in any number of production and/or heating processes. FIG. 175 depicts an end view representation of an embodiment of wellbore 490 in a treatment area undergoing a combustion process using circulated molten salt to recover energy from the treatment area. In FIG. 175, oxidizing fluids are conveyed into wellbore 490 through first conduits 882. Heated fluids, resulting from the combustion process, are conveyed through

second conduits **884**. Heat transfer fluids used to recover energy are conveyed through heat transfer fluid conduit **742**. In the embodiment depicted in FIG. **175**, different conduits are used for injecting/extracting fluids; however, in some embodiments, the same conduit(s) may be used for both injecting and/or extracting fluids. Portions of conduits and/or portions of the wellbore that are positioned in the overburden may be insulated to minimize heat losses in the overburden to increase the efficiency of the energy recovery process.

[1226] Within the treatment area itself, the first and/or second conduits may include multiple openings that act as outlets for oxidizing fluids and/or inlets for heated fluids. The conduits may be positioned in the wellbore during the initial heat treatment cycle (for example, when heating the formation with molten salt). In some embodiments, before insertion into the formation, the conduits include the multiple openings to be used during the energy recovery cycle after the initial heating cycle. In such embodiments, the conduits may be monitored during the initial heating cycle to ensure the multiple openings remain open and do not get clogged (for example, with coke). In some embodiments, intermittent cycling of a pressurized fluid may be used to keep the openings unclogged.

[1227] In some embodiments, the initial openings in the conduits may be smaller than required for the combustion process; however, after the initial heat treatment cycle, the openings may be enlarged (for example, with a mandrel or other tool) while positioned within the wellbore.

[1228] In some embodiments, the conduits are removed after the initial heating cycle of the formation in order to form the necessary openings in the conduits. The formation may be allowed to cool sufficiently (for example, by circulating water in the formation) such that the conduits may be handled in a safe manner before extracting the conduits.

[1229] Energy recovered from the first portion of the formation may be used for many different processes. One example, as mentioned above, is using the recovered energy to heat the second portion of the formation for various in situ conversion processes. Typically, however, a stable and dependable source of heat for upconverting hydrocarbons in situ is desired. Due to the different pressurization cycles of the coke and/or residual oil combustion process, providing a stable and dependable heat source from the combustion process may be difficult. In some embodiments, the fluctuations in the energy provided from the combustion process may be overcome by linking several wellbores to the surface heat exchanger. The wellbores may be at different phases of the combustion cycle such that over a specified time period the average energy output of the collection of wellbores is substantially stable and consistent relative to the needs of the process using the energy.

[1230] Issues associated with combusting coke in the treatment area using the aforementioned wellbore pressurization cycles may include overheating of the rock and/or wellbore during the combustion process. In certain embodiments, recovering energy from the formation using the combustion of coke enriched treatment areas includes regulating the temperature of the wellbore and/or the treatment area. The temperature of the wellbore and/or the adjoining treatment area may be regulated by adjusting the oxidizing fluid flow rate. Adjusting the flow rate of the oxidizing fluid into the wellbore may assist in controlling the combustion process in the treatment area and, thus, the temperature.

[1231] In some embodiments, the temperature of the wellbore and/or the adjoining treatment area are regulated by adjusting the difference in pressure between the pressurization and depressurization phases of the cycle. In some embodiments, the temperature of the wellbore and/or the adjoining treatment area are regulated by adjusting the duration of the combustion process itself. In some embodiments, the temperature of the wellbore and/or the adjoining treatment area are regulated by injecting steam in the wellbore to reduce and/or control the temperature.

[1232] In some embodiments, issues with combusting coke in the treatment area using the aforementioned wellbore pressurization cycles include oxidizing fluids injected in the wellbore moving beyond the desired treatment area and into the surrounding formation. Oxidizing fluids moving beyond the treatment area may decrease the efficiency of the combustion within the treatment area. In some embodiments, a barrier is created in the formation. The barrier may be formed around at least a portion of a perimeter of the treatment area. The barrier may function to inhibit oxidizing fluids introduced in the wellbore from being conveyed beyond the treatment area surrounding the wellbore. Creating the barrier around the treatment area may function to increase the efficiency of the combustion process. Increasing the efficiency of the process may reduce the amount of carbon dioxide produced. Barriers may result in the reduction of energy losses due to unproduced fluids.

[1233] In some embodiments, a barrier forming fluid is introduced around the treatment area surrounding the wellbore. The barrier forming fluid may form the barrier around the treatment area under the proper conditions. The barrier forming fluid may block undesirable flow pathways for the oxidizing gases under the proper conditions. For example, the barrier forming fluid may function to solidify into a solid barrier under certain conditions. The barrier forming fluid may function to solidify at or above a certain temperature range.

[1234] In some embodiments, the barrier forming fluid includes a slurry. The slurry may be formed from solids mixed with a low volatility solvent. Solids included in the barrier forming fluid may include, but not be limited to, ceramics, micas, and/or clays. Low volatility solvents may include polyglycols, high temperature greases or condensable hydrocarbons, and/or other polymeric materials.

[1235] Barrier forming fluids may include compositions generally referred to as Lost Circulation Materials (LCMs). LCMs are used during drilling of wellbores to seal off relatively high or low pressure zones. When a drill bit encounters a high or low pressure zone in a subsurface hydrocarbon containing formation, drilling may be interrupted due to the loss of drilling fluid. Low pressure zones (for example, highly fractured rock) may result in bleed off and subsequent lost circulation of drilling fluid. High pressure zones may result in underground blow-outs and subsequent lost circulation of drilling fluid.

[1236] LCMs may include waste products, which can be obtained relatively inexpensively. Waste products may be obtained from food processing (for example, ground peanut shells, walnut shells, plant fibers, cottonseed hulls) or chemical manufacturing (for example, mica, cellophane, calcium carbonate, ground rubber, polymeric materials) industries. LCMs may be classified based on their properties. For example, there are formation bridging LCMs and seepage

loss LCMs. Sometimes, more than one LCM type may be combined and placed down hole, based on the required LCM properties.

[1237] In some embodiments, issues associated with combusting coke in the treatment area using the aforementioned wellbore pressurization cycles include decreased geological stability in the formation upon removal of the coke. As coke is burned and removed during the combustion process, voids may be created in the subsurface formation, especially in the treatment area. The voids created in the formation may lead to instability in the formation. Typically, however, a majority of coke in the formation is concentrated within a relatively small area around wellbores. In some embodiments, after combustion of coke within the treatment area, structural instability is limited to at most about 10 feet, at most about 6 feet, or at most about 3 feet from the wellbore. It is estimated that greater than about 80% of the coke in the area to be treated is typically within 3 feet of the wellbore. If structural instability is limited to such a relatively small area of the formation, then the instability may not cause significant hazards if appropriate precautions are taken. In some embodiments, the extent of any regions of instability due to combustion of coke is controlled by limiting the size of the treatment area using barriers.

[1238] FIG. 176 depicts percentage of the expected coke distribution relative to a distance from a wellbore. Two wellbores 490 are represented in FIG. 176 and curves 886-892 are the expected amount of coke volume fraction (ft^3/ft^3) as a function of distance from the wellbore relative to the time period of the initial in situ heat treatment process of the formation. Curve 886 represents a coke distribution expected after 730 days of in situ heat treatment process in the formation. After 730 days there is expected to be about 47% coke, most of which is within about 3 feet of the wellbore. Curve 888 represents a coke distribution expected after 1460 days of in situ heat treatment process in the formation. After 1460 days there is expected to be about 94% coke, most of which is within about 3 feet of the wellbore. Curve 890 represents a coke distribution expected after 2190 days of in situ heat treatment process in the formation. After 2190 days there is expected to be about 99% coke, most of which is within about 10 feet of the wellbore. Curve 892 represents a coke distribution expected after 2920 days of in situ heat treatment process in the formation. After 2920 days there is expected to be about 99% coke, most of which is within about 10 feet-20 of the wellbore. Curves 888-892 demonstrate that the longer the in situ heat treatment process is continued, the further away from the wellbore the coke begins to accumulate.

[1239] In some embodiments, nuclear energy is used to heat the heat transfer fluid used in a circulation system to heat a portion of the formation. For example, heat supply 708 in FIG. 141 may be a pebble bed reactor or other type of nuclear reactor, such as a light water reactor or a fissile metal hydride reactor. The use of nuclear energy provides a heat source with little or no carbon dioxide emissions. Also, in some embodiments, the use of nuclear energy is more efficient because energy losses resulting from the conversion of heat to electricity and electricity to heat are avoided by directly utilizing the heat produced from the nuclear reactions without producing electricity.

[1240] In some embodiments, a nuclear reactor heats a heat transfer fluid such as helium. For example, helium flows through a pebble bed reactor, and heat transfers to the helium. The helium may be used as the heat transfer fluid to heat the

formation. In some embodiments, the nuclear reactor heats helium, and the helium is passed through a heat exchanger to provide heat to another heat transfer fluid used to heat the formation. The nuclear reactor may include a pressure vessel that contains encapsulated enriched uranium dioxide fuel. Helium may be used as a heat transfer fluid to remove heat from the nuclear reactor. Heat may be transferred in a heat exchanger from the helium to the heat transfer fluid used in the circulation system. The heat transfer fluid used in the circulation system may be carbon dioxide, a molten salt, or other fluids. It is of course possible that a heat transfer fluid may not actually be a fluid at certain temperatures. A heat transfer fluid may have many of the properties of a solid at lower temperatures and a fluid at higher temperatures. Pebble bed reactor systems are available, for example, from PBMR Ltd (Centurion, South Africa).

[1241] FIG. 177 depicts a schematic diagram of a system that uses nuclear energy to heat treatment area 730. The system may include helium system gas mover 894, nuclear reactor 896, heat exchanger unit 898, and heat transfer fluid mover 900. Helium system gas mover 894 may blow, pump, or compress heated helium from nuclear reactor 896 to heat exchanger unit 898. Helium from heat exchanger unit 898 may pass through helium system gas mover 894 to nuclear reactor 896. Helium from nuclear reactor 896 may be at a temperature between about 900° C. and about 1000° C. Helium from helium gas mover 894 may be at a temperature between about 500° C. and about 600° C. Heat transfer fluid mover 900 may draw heat transfer fluid from heat exchanger unit 898 through treatment area 730. Heat transfer fluid may pass through heat transfer fluid mover 900 to heat exchanger unit 898. The heat transfer fluid may be carbon dioxide, a molten salt, and/or other fluids. The heat transfer fluid may be at a temperature between about 850° C. and about 950° C. after exiting heat exchanger unit 898.

[1242] In some embodiments, the system includes auxiliary power unit 902. In some embodiments, auxiliary power unit 902 generates power by passing the helium from heat exchanger unit 898 through a generator to make electricity. The helium may be sent to one or more compressors and/or heat exchangers to adjust the pressure and temperature of the helium before the helium is sent to nuclear reactor 896. In some embodiments, auxiliary power unit 902 generates power using a heat transfer fluid (for example, ammonia or aqua ammonia). Helium from heat exchanger unit 898 may be sent to additional heat exchanger units to transfer heat to the heat transfer fluid. The heat transfer fluid may be taken through a power cycle (such as a Kalina cycle) to generate electricity. In an embodiment, nuclear reactor 896 is a 400 MW reactor and auxiliary power unit 902 generates about 30 MW of electricity.

[1243] FIG. 178 depicts a schematic elevational view of an arrangement for an in situ heat treatment process. Wellbores (which may be U-shaped or in other shapes) may be formed in the formation to define treatment areas 730A, 730B, 730C, 730D. Additional treatment areas could be formed to the sides of the shown treatment areas. Treatment areas 730A, 730B, 730C, 730D may have widths of over 300 m, 500 m, 1000 m, or 1500 m. Well exits and entrances for the wellbores may be formed in well openings area 904. Rail lines 906 may be formed along sides of treatment areas 730. Warehouses, administration offices, and/or spent fuel storage facilities may be located near ends of rail lines 906. Facilities 908 may be formed at intervals along spurs of rail lines 906. Facilities 908

may include a nuclear reactor, compressors, heat exchanger units, and/or other equipment needed for circulating hot heat transfer fluid to the wellbores. Facilities **908** may also include surface facilities for treating formation fluid produced from the formation. In some embodiments, heat transfer fluid produced in facility **908'** may be reheated by the reactor in facility **908''** after passing through treatment area **730A**. In some embodiments, each facility **908** is used to provide hot treatment fluid to wells in one half of the treatment area **730** adjacent to the facility. Facilities **908** may be moved by rail to another facility site after production from a treatment area is completed.

[1244] In some embodiments, nuclear energy is used to directly heat a portion of a subsurface formation. The portion of the subsurface formation may be part of a hydrocarbon treatment area. As opposed to using a nuclear reactor facility to heat a heat transfer fluid, which is then provided to the subsurface formation to heat the subsurface formation, one or more self-regulating nuclear heaters may be positioned underground to directly heat the subsurface formation. The self-regulating nuclear reactor may be positioned in or proximate to one or more tunnels.

[1245] In some embodiments, treatment of the subsurface formation requires heating the formation to a desired initial upper range (for example, between about 250° C. and 350° C.). After heating the subsurface formation to the desired temperature range, the temperature may be maintained in the range for a desired time (for example, until a percentage of hydrocarbons have been pyrolyzed or an average temperature in the formation reaches a selected value). As the formation temperature rises, the heater temperature may be slowly lowered over a period of time. Currently, certain nuclear reactors described herein (for example, nuclear pebble bed reactors), upon activation, reach a natural temperature output limit of about 900° C., eventually decaying as the uranium-235 fuel is depleted and resulting in lower temperatures produced over time at the heater. The natural power output curve of certain nuclear reactors (for example, nuclear pebble bed reactors) may be used to provide a desired heating versus time profile for certain subsurface formations.

[1246] In some embodiments, nuclear energy is provided by a self-regulating nuclear reactor (for example, a pebble bed reactor or a fissile metal hydride reactor). The self-regulating nuclear reactor may not exceed a certain temperature based upon its design. The self-regulating nuclear reactor may be substantially compact relative to traditional nuclear reactors. The self-regulating nuclear reactor may be, for example, approximately 2 m, 3 m, or 5 m square or even less in size. The self-regulating nuclear reactor may be modular.

[1247] FIG. 179 depicts a schematic representation of self-regulating nuclear reactor **910**. In some embodiments, the self-regulating nuclear reactor includes fissile metal hydride **912**. The fissile metal hydride may function as both fuel for the nuclear reaction as well as a moderator for the nuclear reaction. A core of the nuclear reactor may include a metal hydride material. The temperature driven mobility of the hydrogen isotope contained in the hydride may function to control the nuclear reaction. If the temperature increases above a set point in core **914** of self-regulating nuclear reactor **910**, a hydrogen isotope dissociates from the hydride and escapes out of the core and the power production decreases. If the core temperature decreases, the hydrogen isotope reassociates with the fissile metal hydride reversing the process. In some embodiments, the fissile metal hydride may be in a

powdered form, which allows hydrogen to more easily permeate the fissile metal hydride.

[1248] Due to its basic design, the self-regulating nuclear reactor may include few, if any, moving parts associated with the control of the nuclear reaction itself. The small size and simple construction of the self-regulating nuclear reactor may have distinct advantages, especially relative to conventional commercial nuclear reactors used commonly throughout the world today. Advantages may include relative ease of manufacture, transportability, security, safety, and financial feasibility. The compact design of self-regulating nuclear reactors may allow for the reactor to be constructed at one facility and transported to a site of use, such as a hydrocarbon containing formation. Upon arrival and installation, the self-regulating nuclear reactor may be activated.

[1249] Self-regulating nuclear reactors may produce thermal power on the order of tens of megawatts per unit. Two or more self-regulating nuclear reactors may be used at the hydrocarbon containing formation. Self-regulating nuclear reactors may operate at a fuel temperature ranging between about 450° C. and about 900° C., between about 500° C. and about 800° C., or between about 550° C. and about 650° C. The operating temperature may be in the range between about 550° C. and about 600° C. The operating temperature may be in the range between about 500° C. and about 650° C.

[1250] Self-regulating nuclear reactors may include energy extraction system **916** in core **914**. Energy extraction system **916** may function to extract energy in the form of heat produced by the activated nuclear reactor. The energy extraction system may include a heat transfer fluid that circulates through piping **916A** and **916B**. At least a portion of the tubing may be positioned in the core of the nuclear reactor. A fluid circulation system may function to continuously circulate heat transfer fluid through the piping. Density and volume of piping positioned in the core may be dependent on the enrichment of the fissile metal hydride.

[1251] In some embodiments, the energy extraction system includes alkali metal (for example, potassium) heat pipes. Heat pipes may further simplify the self-regulating nuclear reactor by eliminating the need for mechanical pumps to convey a heat transfer fluid through the core. Any simplification of the self-regulating nuclear reactor may decrease the chances of any malfunctions and increase the safety of the nuclear reactor. The energy extraction system may include a heat exchanger coupled to the heat pipes. Heat transfer fluids may convey thermal energy from the heat exchanger.

[1252] The dimensions of the nuclear reactor may be determined by the enrichment of the fissile metal hydride. Nuclear reactors with a higher enrichment result in smaller relative reactors. Proper dimensions may be ultimately determined by particular specifications of a hydrocarbon containing formation and the formation's energy needs. In some embodiments, the fissile metal hydride is diluted with a fertile hydride. The fertile hydride may be formed from a different isotope of the fissile portion. The fissile metal hydride may include the fissile hydride U^{235} and the fertile hydride may include the isotope U^{238} . In some embodiments, the core of the nuclear reactor may include a nuclear fuel formed from about 5% of U^{235} and about 95% of U^{238} .

[1253] Other combinations of fissile metal hydrides mixed with fertile or non-fissile hydrides will also work. The fissile metal hydride may include plutonium. Plutonium's low melting temperature (about 640° C.) makes the hydride particles less attractive as a reactor fuel to power a steam generator, but

may be useful in other applications requiring lower reactor temperatures. The fissile metal hydride may include thorium hydride. Thorium permits higher temperature operation of the reactor because of its high melting temperature (about 1755° C.). In some embodiments, different combinations of fissile metal hydrides are used in order to achieve different energy output parameters.

[1254] In some embodiments, nuclear reactor 910 may include one or more hydrogen storage containers 918. A hydrogen storage container may include one or more non-fissile hydrogen absorbing materials to absorb the hydrogen expelled from the core. The non-fissile hydrogen absorbing material may include a non-fissile isotope of the core hydride. The non-fissile hydrogen absorbing material may have a hydride dissociation pressure close to that of the fissile material.

[1255] Core 914 and hydrogen storage containers 918 may be separated by insulation layer 920. The insulation layer may function as a neutron reflector to reduce neutron leakage from the core. The insulation layer may function to reduce thermal feedback. The insulation layer may function to protect the hydrogen storage containers from being heated by the nuclear core (for example, with radiative heating or with convective heating from the gas within the chamber).

[1256] The effective steady-state temperature of the core may be controlled by the ambient hydrogen gas pressure. The ambient hydrogen gas pressure may be controlled by the temperature at which the non-fissile hydrogen absorbing material is maintained. The temperature of the fissile metal hydride may be independent of the amount of energy being extracted. The energy output may be dependent on the ability of the energy extraction system to extract the power from the nuclear reactor.

[1257] Hydrogen gas in the reactor core may be monitored for purity and periodically repressurized to maintain the correct quantity and isotopic content. In some embodiments, the hydrogen gas is maintained via access to the core of the nuclear reactor through one or more pipes (for example, pipes 922A and 922B). The temperature of the self-regulating nuclear reactor may be controlled by controlling a pressure of hydrogen supplied to the self-regulating nuclear reactor. The pressure may be regulated based upon the temperature of the heat transfer fluid at one or more points (for example, at the point where the heat transfer fluid enters one or more wellbores). In some embodiments, the pressure may be regulated, and therefore the thermal energy produced by the self-regulating nuclear reactor, based on one or more conditions associated with the formation being treated. Formation conditions may include, for example, temperature of a portion of the formation, type of formation (for example, coal or tar sands), and/or type of processing method being applied to the formation.

[1258] In some embodiments, the nuclear reaction occurring in the self-regulating nuclear reactor may be controlled by introducing a neutron-absorbing gas. The neutron-absorbing gas may, in sufficient quantities, quench the nuclear reaction in the self-regulating nuclear reactor (ultimately reducing the temperature of the reactor to ambient temperature). Neutron-absorbing gases may include xenon¹³⁵.

[1259] In some embodiments, the nuclear reaction of an activated self-regulating nuclear reactor is controlled using control rods. Control rods may be positioned at least partially in at least a portion of the nuclear core of the self-regulating nuclear reactor. Control rods may be formed from one or

more neutron-absorbing materials. Neutron-absorbing materials may include, but not be limited to, silver, indium, cadmium, boron, cobalt, hafnium, dysprosium, gadolinium, samarium, erbium, and/or europium.

[1260] Currently, self-regulating nuclear reactors described herein, upon activation, reach a natural temperature output limit of about 900° C., eventually decaying as the fuel is depleted. The natural power output curve of self-regulating nuclear reactors may be used to provide a desired heating versus time profile for certain subsurface formations.

[1261] In some embodiments, self-regulating nuclear reactors may have a natural energy output which decays at a rate of about 1/E (E is sometimes referred to as Euler's number and is equivalent to about 2.71828). In some embodiments, self-regulating nuclear reactors may have a natural power output that decays to 1/E of the initial power in a period of time of about 4 years to about 8 years. Typically, once a formation has been heated to a desired temperature, less heat is required and the amount of thermal energy put into the formation in order to heat the formation is reduced over time. In some embodiments, heat input to at least a portion of the formation over time approximately correlates to a rate of decay of the power from the self-regulating nuclear reactor. Due to the natural decay of at least some self-regulating nuclear reactors, heating systems may be designed such that the heating systems take advantage of the natural rate of decay of the power from a nuclear reactor. Heating systems typically include two or more heaters. Heaters are typically positioned in wellbores placed throughout the formation. Wellbores may include, for example, U-shaped and L-shaped wellbores or other shapes of wellbores. In some embodiments, spacing between wellbores is determined based on the decay rate of the power output of self-regulating nuclear reactors.

[1262] The self-regulating nuclear reactor may initially provide, to at least a portion of the wellbores, an power output of about 300 watts/foot; and thereafter decreasing over a predetermined time period to about 120 watts/foot. The predetermined time period may be determined by the design of the self-regulating nuclear reactor itself (for example, fuel used in the nuclear core as well as the enrichment of the fuel). The natural decrease in power output may match power injection versus time dependence of the formation. Either variable (for example, power output and/or power injection) may be adjusted so that the two variables at least approximately correlate or match. The self-regulating nuclear reactor may be designed to decay over a period of 4-9 years, 5-7 years, or about 7 years. The decay period of the self-regulating nuclear reactor may correspond to an IUP (in situ upgrading process) and/or an ICP (in situ conversion process) heating cycle.

[1263] In some embodiments, spacing between heater wellbores depends on a rate of decay of one or more nuclear reactors used to provide power. In some embodiments, spacing between heater wellbores ranges between about 8 meters and about 11 meters, between about 9 meters and about 10 meters, or between about 9.4 meters and about 9.8 meters.

[1264] In certain situations, it may be advantageous to continue a particular level of power output of the self-regulating nuclear reactor for a longer period than the natural decay of the fuel material in the nuclear core would normally allow. In some embodiments, in order to keep the level of output within a desired range, a second self-regulating nuclear reactor may be coupled to the formation being treated (for example, being heated). The second self-regulating nuclear reactor may, in

some embodiments, have a decayed power output. The power output of the second reactor may have already decreased due to prior use. The power output of the two self-regulating nuclear reactors may be substantially equivalent to the initial power output of the first self-regulating nuclear reactor and/or a desired power output. Additional self-regulating nuclear reactors may be coupled to the formation as needed to achieve the desired power output. Such a system may advantageously increase the effective useful lifetime of the self-regulating nuclear reactors.

[1265] The effective useful lifetime of self-regulating nuclear reactors may be extended by using the thermal energy produced by the nuclear reactor to produce steam which, depending upon the formation and/or systems used, may require far less thermal energy than other uses outlined herein. Steam may be used for a number of purposes including, but not limited to, producing electricity, producing hydrogen on site, converting hydrocarbons, and/or upgrading hydrocarbons. Hydrocarbons may be converted and/or mobilized in situ by injecting the produced steam in the formation.

[1266] A product stream (for example, a stream including methane, hydrocarbons, and/or heavy hydrocarbons) may be produced from a formation heated with heat transfer fluids that are heated by the nuclear reactor. Steam produced from heat generated by the nuclear reactor or a second nuclear reactor may be used to reform at least a portion of the product stream. The product stream may be reformed to make at least some molecular hydrogen.

[1267] The molecular hydrogen may be used to upgrade at least a portion of the product stream. The molecular hydrogen may be injected in the formation. The product stream may be produced from a surface upgrading process. The product stream may be produced from an in situ heat treatment process. The product stream may be produced from a subsurface steam heating process.

[1268] At least a portion of the steam may be injected into a subsurface steam heating process. At least some of the steam may be used to reform methane. At least some of the steam may be used for electrical generation. At least a portion of the hydrocarbons in the formation may be mobilized by the steam and/or heat from the steam.

[1269] In some embodiments, self-regulating nuclear reactors may be used to produce electricity (for example, via steam driven turbines). The electricity may be used for any number of applications normally associated with electricity. Specifically, the electricity may be used for applications associated with in situ heat treatment processes requiring energy. Electricity from self-regulating nuclear reactors may be used to provide energy for downhole electric heaters. Electricity may be used to cool fluid for forming a low temperature barrier (frozen barrier) around treatment areas, and/or for providing electricity to treatment facilities located at or near the in situ heat treatment process site. In some embodiments, the electricity produced by the nuclear reactors is used to resistively heat the conduits used to circulate heat transfer fluid through the treatment area. In some embodiments, nuclear power is used to generate electricity that operates compressors and/or pumps (compressors/pumps provide compressed gases (such as oxidizing fluid and/or fuel to a plurality of oxidizer assemblies) to a treatment area) needed for the in situ heat treatment process. A significant cost of the in situ heat treatment process may be operating the compressors and/or pumps over the life of the in situ heat treatment

process if conventional electrical energy sources are used to power the compressors and/or pumps of the in situ heat treatment process.

[1270] Converting heat from self-regulating nuclear reactors into electricity may not be the most efficient use of the thermal energy produced by the nuclear reactors. In some embodiments, thermal energy produced by self-regulating nuclear reactors is used to directly heat portions of a formation. In some embodiments, one or more self-regulating nuclear reactors are positioned underground in the formation such that thermal energy produced directly heats at least a portion of the formation. One or more self-regulating nuclear reactors may be positioned underground in the formation below the overburden thus increasing the efficient use of the thermal energy produced by the self-regulating nuclear reactors. Self-regulating nuclear reactors positioned underground may be encased in a material for further protection. For example, self-regulating nuclear reactors positioned underground may be encased in a concrete container.

[1271] In some embodiments, thermal energy produced by self-regulating nuclear reactors may be extracted using heat transfer fluids. Thermal energy produced by self-regulating nuclear reactors may be transferred to and distributed through at least a portion of the formation using heat transfer fluids. Heat transfer fluids may circulate through the piping of the energy extraction system of the self-regulating nuclear reactor. As heat transfer fluids circulate in and through the core of the self-regulating nuclear reactor, the heat produced from the nuclear reaction heats the heat transfer fluids.

[1272] In some embodiments, two or more heat transfer fluids may be employed to transfer thermal energy produced by self-regulating nuclear reactors. A first heat transfer fluid may circulate through the piping of the energy extraction system of the self-regulating nuclear reactor. The first heat transfer fluid may pass through a heat exchanger and used to heat a second heat transfer fluid. The second heat transfer fluid may be used for treating hydrocarbon fluids in situ, powering electrolysis unit, and/or for other purposes. The first heat transfer fluid and the second heat transfer fluid may be different materials. Using two heat transfer fluids may reduce the risk of unnecessary exposure of systems and personnel to any radiation absorbed by the first heat transfer fluid. Heat transfer fluids that are resistant to absorbing nuclear radiation may be used (for example, nitrite salts or nitrate salts).

[1273] In some embodiments, the energy extraction system includes alkali metal (for example, potassium) heat pipes. Heat pipes may further simplify the self-regulating nuclear reactor by eliminating the need for mechanical pumps to convey a heat transfer fluid through the core. Any simplification of the self-regulating nuclear reactor may decrease the chances of any malfunctions and increase the safety of the nuclear reactor. The energy extraction system may include a heat exchanger coupled to the heat pipes. Heat transfer fluids may convey thermal energy from the heat exchanger.

[1274] Heat transfer fluids may include natural or synthetic oil, molten metal, molten salt, or other types of high temperature heat transfer fluid. The heat transfer fluid may have a low viscosity and a high heat capacity at normal operating conditions. When the heat transfer fluid is a molten salt or other fluid that has the potential to solidify in the formation, piping of the system may be electrically coupled to an electricity source to resistively heat the piping when needed and/or one or more heaters may be positioned in or adjacent to the piping to maintain the heat transfer fluid in a liquid state. In some

embodiments, an insulated conductor heater is placed in the piping. The insulated conductor may melt solids in the pipe.

[1275] In some embodiments, heat transfer fluids include molten salts. Molten salts function well as heat transfer fluids due to their typically stable nature as a solid and a liquid, their relatively high heat capacity, and unlike water, their lack of expansion when they solidify. Molten salts have a fairly high melting point and typically a large range over which the salt is liquid before it reaches a temperature high enough to decompose. Due to the wide variety of salts, a salt with a desirable temperature range may be found. If necessary, a mixture of different salts may be used in order to achieve a molten salt mixture with the appropriate properties (for example, an appropriate temperature range).

[1276] In some embodiments, the molten salt includes a nitrite salt or a combination of nitrite salts. Examples of different nitrite salts may include lithium, sodium, and/or potassium nitrite salts. The molten salt may include about 15 wt. % to about 50 wt. % potassium nitrite salts and about 50 wt. % to about 80 wt. % sodium nitrite salts. The molten salt may include a nitrate salt or a combination of nitrate salts. Examples of different nitrate salts may include lithium, sodium, and/or potassium nitrate salts. The molten salt may include about 15 wt. % to about 60 wt. % potassium nitrate salts and about 40 wt. % to about 80 wt. % sodium nitrate salts. The molten salt may include a mixture of nitrite and nitrate salts. In some embodiments, the molten salt may include HITEC and/or HITEC XL which are available from Coastal Chemical Co., L.L.C. located in Abbeville, La., U.S.A. HITEC may include a eutectic mixture of sodium nitrite, sodium nitrate, and potassium nitrate. HITEC may include a recommended operating temperature range of between about 149° C. and about 538° C. HITEC XL may include a eutectic mixture of calcium nitrate, sodium nitrate, and potassium nitrate. In some embodiments, a manufacturing facility may be used to convert nitrite salts to nitrate salts and/or nitrate salts to nitrite salts.

[1277] In some embodiments, the molten salt includes a customized mixture of different salts that achieve a desirable temperature range. A desirable temperature range may be dependent upon the formation and/or material being heated with the molten salt. TABLE 7 depicts ranges of different mixtures of nitrate salts. TABLE 7 demonstrates how varying a ratio of a mixture of different salts may affect the salt's usable temperature range as a heat transfer fluid. For example, a lithium doped nitrate salt mixture (for example, Li:Na:K: NO₃) has several advantages over the non lithium doped nitrate salt mixture (for example, Na:K:NO₃). The Li:Na:K: NO₃ salt mixture may offer a large operating temperature range. The Li:Na:K:NO₃ salt mixture may have a lower melting point, which reduces the preheating requirements.

TABLE 7

NO ₃ Salts	Composition (wt. %)	Melting Point (° C.)	Upper Limit (° C.)
Na:K	60:40	230	565
Li:Na:K	12:18:70	200	550
Li:Na:K	20:28:52	150	550
Li:Na:K	27:33:40	160	550
Li:Na:K	30:18:52	120	550

[1278] In some embodiments, pressurized hot water is used to preheat the piping in heater wellbores such that molten salts may be used. Preheating piping in heater wellbores (for

example, to at least approximate the melting point of the molten salt to be used) may inhibit molten salts from freezing and occluding the piping when the molten salt is first circulated through the piping. Piping in the heater wellbore may be preheated using pressurized hot water (for example, water at about 120° C. pressurized to about 15 psi). The piping may be heated until at least a majority of the piping reaches a temperature approximate to the circulating hot water temperature. In some embodiments, the hot water is flushed from the piping with air after the piping has been heated to the desired temperature. A preheated molten salt (for example, Li:Na:K: NO₃) may then be circulated through the piping in the heater wellbores to achieve the desired temperature.

[1279] In some embodiments, a salt (for example, Li:Na:K:NO₃) is dissolved in water to form a salt solution before circulating the salt through piping in heater wellbores. Dissolving the salt in water may reduce the freezing point (for example, from about 120° C. to about 0° C.) such that the salt may be safely circulated through the piping with little fear of the salt freezing and obstructing the piping. The salt solution, in some embodiments, is preheated (for example, to about 90° C.) before circulating the solution through the piping in heater wellbores. The salt solution may be heated at an elevated pressure (for example, greater than about 15 psi) to above the water's boiling point. As the salt solution is heated to about 120° C., the water from the solution may evaporate. The evaporating water may be allowed to vent from the heat transfer fluid circulation system. Eventually, only the anhydrous molten salt remains to heat the formation.

[1280] In some embodiments, preheating of piping in heater wellbores is accomplished by a heat trace (for example, an electric heat trace). The heat trace may be accomplished by using a cable and/or running current directly through the pipe. In some embodiments, a relatively thin conductive layer is used to provide the majority of the electrically resistive heat output of the temperature limited heater at temperatures up to a temperature at or near the Curie temperature and/or the phase transformation temperature range of the ferromagnetic conductor. Such a temperature limited heater may be used as the heating member in an insulated conductor heater. The heating member of the insulated conductor heater may be located inside a sheath with an insulation layer between the sheath and the heating member.

[1281] FIG. 180 depicts a schematic representation of an embodiment of an in situ heat treatment system positioned in formation 492 with u-shaped wellbores 924 using self-regulating nuclear reactors 910. Self-regulating nuclear reactors 910, depicted in FIG. 180, may produce about 70 MWthermal. In some embodiments, spacing between wellbores 924 is determined based on the decay rate of the energy output of self-regulating nuclear reactors 910.

[1282] U-shaped wellbores may run down through overburden 400 and into hydrocarbon containing layer 388. The piping in wellbores 924 adjacent to overburden 400 may include insulated portion 926. Insulated storage tanks 928 may receive molten salt from the formation 492 through piping 930. Piping 930 may transport molten salts with temperatures ranging from about 350° C. to about 500° C. Temperatures in the storage tanks may be dependent on the type of molten salt used. Temperatures in the storage tanks may be in the vicinity of about 350° C. Pumps may move the molten salt to self-regulating nuclear reactors 910 through piping 932. Each of the pumps may need to move, for example, 6 kg/sec to 12 kg/sec of the molten salt. Each self-regulating nuclear

reactor **910** may provide heat to the molten salt. The molten salt may pass from piping **934** to wellbores **924**. The heated portion of wellbore **924** that passes through layer **388** may extend, in some embodiments, from about 8,000 feet (about 2400 m) to about 10,000 feet (about 3000 m). Exit temperatures of the molten salt from self-regulating nuclear reactors **910** may be about 550° C. Each self-regulating nuclear reactor **910** may supply molten salt to about 20 or more wellbores **924** that enter into the formation. The molten salt flows through the formation and back to storage tanks **928** through piping **930**.

[1283] In some embodiments, nuclear energy is used in a cogeneration process. In an embodiment for producing hydrocarbons from a hydrocarbon containing formation (for example, a tar sands formation), produced hydrocarbons may include one or more portions with heavy hydrocarbons. Hydrocarbons may be produced from the formation using more than one process. In certain embodiments, nuclear energy is used to assist in producing at least some of the hydrocarbons. At least some of the produced heavy hydrocarbons may be subjected to pyrolysis temperatures. Pyrolysis of the heavy hydrocarbons may be used to produce steam. Steam may be used for a number of purposes including, but not limited to, producing electricity, converting hydrocarbons, and/or upgrading hydrocarbons.

[1284] In some embodiments, a heat transfer fluid is heated using a self-regulating nuclear reactor. The heat transfer fluid may be heated to temperatures that allow for steam production (for example, from about 550° C. to about 600° C.). In some embodiments, in situ heat treatment process gas and/or fuel passes to a reformation unit. In some embodiments, in situ heat treatment process gas is mixed with fuel and then passed to the reformation unit. A portion of in situ heat treatment process gas may enter a gas separation unit. The gas separation unit may remove one or more components from the in situ heat treatment process gas to produce the fuel and one or more other streams (for example, carbon dioxide or hydrogen sulfide). The fuel may include, but not be limited to, hydrogen, hydrocarbons having a carbon number of at most 5, or mixtures thereof.

[1285] The reformer unit may be a steam reformer. The reformer unit may combine steam with a fuel (for example, methane) to produce hydrogen. For example, the reformation unit may include water gas shift catalysts. The reformation unit may include one or more separation systems (for example, membranes and/or a pressure swing adsorption system) capable of separating hydrogen from other components. Reformation of the fuel and/or the in situ heat treatment process gas may produce a hydrogen stream and a carbon oxide stream. Reformation of the fuel and/or the in situ heat treatment process gas may be performed using techniques known in the art for catalytic and/or thermal reformation of hydrocarbons to produce hydrogen. In some embodiments, electrolysis is used to produce hydrogen from the steam. A portion or all of the hydrogen stream may be used for other purposes such as, but not limited to, an energy source and/or a hydrogen source for in situ or ex situ hydrogenation of hydrocarbons.

[1286] Self-regulating nuclear reactors may be used to produce hydrogen at facilities located adjacent to hydrocarbon containing formations. The ability to produce hydrogen on site at hydrocarbon containing formations is highly advantageous due to the plurality of ways in which hydrogen is used

for converting and upgrading hydrocarbons on site at hydrocarbon containing formations.

[1287] In some embodiments, the first heat transfer fluid is heated using thermal energy stored in the formation. Thermal energy may result in the formation following a number of different heat treatment methods.

[1288] Self-regulating nuclear reactors have several advantages over many current constant output nuclear reactors. However, there are several new nuclear reactors whose designs have received regulatory approval for construction. Nuclear energy may be provided by a number of different types of available nuclear reactors and nuclear reactors currently under development (for example, generation IV reactors).

[1289] In some embodiments, nuclear reactors include very high temperature reactors (VHTR). VHTRs may use, for example, helium as a coolant to drive a gas turbine for treating hydrocarbon fluids in situ, powering an electrolysis unit, and/or for other purposes. VHTRs may produce heat up to about 950° C. or more. In some embodiments, nuclear reactors include a sodium-cooled fast reactor (SFR). SFRs may be designed on a smaller scale (for example, 50 MWe) and therefore may be more cost effective to manufacture on site for treating hydrocarbon fluids in situ, powering electrolysis units, and/or for other purposes. SFRs may be of a modular design and potentially portable. SFRs may produce temperatures ranging between about 500° C. and about 600° C., between about 525° C. and about 575° C., or between 540° C. and about 560° C.

[1290] In some embodiments, pebble bed reactors are employed to provide thermal energy. Pebble bed reactors may produce up to 165 MWe. Pebble bed reactors may produce temperatures ranging between about 500° C. and about 1100° C., between about 800° C. and about 1000° C., or between about 900° C. and about 950° C. In some embodiments, nuclear reactors include supercritical-water-cooled reactors (SCWR) based at least in part on previous light water reactors (LWR) and supercritical fossil-fired boilers. SCWRs may produce temperatures ranging between about 400° C. and about 650° C., between about 450° C. and about 550° C., or between about 500° C. and about 550° C.

[1291] In some embodiments, nuclear reactors include lead-cooled fast reactors (LFR). LFRs may be manufactured in a range of sizes, from modular systems to several hundred megawatt or more. LFRs may produce temperatures ranging between about 400° C. and about 900° C., between about 500° C. and about 850° C., or between about 550° C. and about 800° C.

[1292] In some embodiments, nuclear reactors include molten salt reactors (MSR). MSRs may include fissile, fertile, and fission isotopes dissolved in a molten fluoride salt with a boiling point of about 1,400° C. The molten fluoride salt may function as both the reactor fuel and the coolant. MSRs may produce temperatures ranging between about 400° C. and about 900° C., between about 500° C. and about 850° C., or between about 600° C. and about 800° C.

[1293] In some in situ heat treatment embodiments, compressors provide compressed gases to the treatment area. For example, compressors may be used to provide oxidizing fluid **678** and/or fuel **936** to a plurality of oxidizer assemblies. Oxidizers may burn a mixture of oxidizing fluid **678** and fuel **936** to produce heat that heats the treatment area in the formation. Also, compressors **714** may be used to supply gas phase heat transfer fluid to the formation as depicted in FIG.

141. In some embodiments, pumps provide liquid phase heat transfer fluid to the treatment area.

[1294] A significant cost of the in situ heat treatment process may be operating the compressors and/or pumps over the life of the in situ heat treatment process if conventional electrical energy sources are used to power the compressors and/or pumps of the in situ heat treatment process. In some embodiments, nuclear power may be used to generate electricity that operates the compressors and/or pumps needed for the in situ heat treatment process. The nuclear power may be supplied by one or more nuclear reactors. The nuclear reactors may be light water reactors, pebble bed reactors, and/or other types of nuclear reactors. The nuclear reactors may be located at or near to the in situ heat treatment process site. Locating the nuclear reactors at or near to the in situ heat treatment process site may reduce equipment costs and electrical transmission losses over long distances. The use of nuclear power may reduce or eliminate the amount of carbon dioxide generation associated with operating the compressors and/or pumps over the life of the in situ heat treatment process.

[1295] Excess electricity generated by the nuclear reactors may be used for other in situ heat treatment process needs. For example, excess electricity may be used to cool fluid for forming a low temperature barrier (frozen barrier) around treatment areas, and/or for providing electricity to treatment facilities located at or near the in situ heat treatment process site. In some embodiments, the electricity or excess electricity produced by the nuclear reactors may be used to resistively heat the conduits used to circulate heat transfer fluid through the treatment area.

[1296] In some embodiments, excess heat available from the nuclear reactors may be used for other in situ processes. For example, excess heat may be used to heat water or make steam that is used in solution mining processes. In some embodiments, excess heat from the nuclear reactors may be used to heat fluids used in the treatment facilities located near or at the in situ heat treatment site.

[1297] In certain embodiments, a solvation fluid and/or pressurizing fluid are used to treat the hydrocarbon formation in addition to the in situ heat treatment process. In some embodiments, a solvation fluid and/or pressurizing fluid is used after the hydrocarbon formation has been treated using a drive process.

[1298] In some embodiments, heaters are used to heat a first section of the formation. For example, heaters may be used to heat a first section of formation to pyrolysis temperatures to produce formation fluids. In some embodiments, heaters are used to heat a first section of the formation to temperatures below pyrolysis temperatures to visbreak and/or mobilize fluids in the formation. In other embodiments, a first section of a formation is heated by heaters prior to, during, or after a drive process is used to produce formation fluids.

[1299] Residual heat from first section may transfer to portions of the formation above, below, and/or adjacent to the first section. The transferred residual heat, however, may not be sufficient to mobilize the fluids in the other portions of the formation towards production wells so that recovery of the fluids from the colder sections fluids may be difficult. Addition of a fluid (for example, a solvation fluid and/or a pressurizing fluid) may solubilize and/or drive the hydrocarbons in the sections of the formation heated by residual heat towards production wells. Addition of a solvating and/or pressurizing fluid to portions of the formation heated by residual

heat may facilitate recovery of hydrocarbons without requiring heaters to heat the additional sections. Addition of the fluid may allow for the recovery of hydrocarbons in previously produced sections and/or for the recovery of viscous hydrocarbons in colder sections of the formation.

[1300] In some embodiments, the formation is treated using the in situ heat treatment process for a significant time after the formation has been treated with a drive process. For example, the in situ heat treatment process is used 1 year, 2 years, 3 years, or longer after a formation has been treated using drive processes. After heating the formation for a significant amount of time using heaters and/or injected fluid (for example, steam), a solvation fluid may be added to the heated section and/or portions above and/or below the heated section. The in situ heat treatment process followed by addition of a solvation fluid and/or a pressurizing fluid may be used on formations that have been left dormant after the drive process treatment because further hydrocarbon production using the drive process is not possible and/or not economically feasible. In some embodiments, the solvation fluid and/or the pressurizing fluid is used to increase the amount of heat provided to the formation. In some embodiments, an in situ heat treatment process may be used following addition of the solvation fluid and/or pressurizing fluid to increase the recovery of hydrocarbons from the formation.

[1301] In some embodiments, the solvation fluid forms an in situ solvation fluid mixture. Using the in situ solvation fluid may upgrade the hydrocarbons in the formation. The in situ solvation fluid may enhance solubilization of hydrocarbons and/or facilitate moving the hydrocarbons from one portion of the formation to another portion of the formation.

[1302] FIGS. 181 and 182 depict side view representations of embodiments for producing a fluid mixture from the hydrocarbon containing formation. In FIGS. 181 and 182, heaters 412 have substantially horizontal heating sections below overburden 400 in hydrocarbon layer 388 (as shown, the heaters have heating sections that go into and out of the page). Heaters 412 provide heat to first section 938 of hydrocarbon layer 388. Patterns of heaters, such as triangles, squares, rectangles, hexagons, and/or octagons may be used within first section 938. First section 938 may be heated at least to temperatures sufficient to mobilize some hydrocarbons within the first section. A temperature of the heated first section 938 may range from about 200° C. to about 240° C. In some embodiments, temperature within first section 938 may be increased to a pyrolyzation temperature (for example between 250° C. and 400° C.).

[1303] In certain embodiments, the bottommost heaters are located between about 2 m and about 10 m from the bottom of hydrocarbon layer 388, between about 4 m and about 8 m from the bottom of the hydrocarbon layer, or between about 5 m and about 7 m from the bottom of the hydrocarbon layer. In certain embodiments, production wells 206A are located at a distance from the bottommost heaters 412 that allows heat from the heaters to superimpose over the production wells, but at a distance from the heaters that inhibits coking at the production wells. Production wells 206A may be located a distance from the nearest heater (for example, the bottommost heater) of at most $\frac{3}{4}$ of the spacing between heaters in the pattern of heaters (for example, the triangular pattern of heaters depicted in FIGS. 181 and 182). In some embodiments, production wells 206A are located a distance from the nearest heater of at most $\frac{2}{3}$, at most $\frac{1}{2}$, or at most $\frac{1}{3}$ of the spacing between heaters in the pattern of heaters. In certain

embodiments, production wells 206A are located between about 2 m and about 10 m from the bottommost heaters, between about 4 m and about 8 m from the bottommost heaters, or between about 5 m and about 7 m from the bottommost heaters. Production wells 206A may be located between about 0.5 m and about 8 m from the bottom of hydrocarbon layer 388, between about 1 m and about 5 m from the bottom of the hydrocarbon layer, or between about 2 m and about 4 m from the bottom of the hydrocarbon layer.

[1304] In some embodiments, formation fluid is produced from first section 938. The formation fluid may be produced through production wells 206A. In some embodiments, the formation fluids drain by gravity to a bottom portion of the layer. The drained fluids may be produced from production wells 206A positioned at the bottom portion of the layer. Production of the formation fluids may continue until a majority of condensable hydrocarbons in the formation fluid are produced. After the majority of the condensable hydrocarbons have been produced, first section 938 heat from heaters 412 may be reduced and/or discontinued to allow a reduction in temperature in the first section. In some embodiments, after the majority of the condensable hydrocarbons have been produced, a pressure of first section 938 may be reduced to a selected pressure after the first section reaches the selected temperature. Selected pressures may range between about 100 kPa and about 1000 kPa, between 200 kPa and 800 kPa, or below a fracture pressure of the formation.

[1305] In some embodiments, the formation fluid produced from production wells 206 includes at least some pyrolyzed hydrocarbons. Some hydrocarbons may be pyrolyzed in portions of first section 938 that are at higher temperatures than a remainder of the first section. For example, portions of formation adjacent to heaters 412 may be at somewhat higher temperatures than the remainder of first section 938. The higher temperature of the formation adjacent to heaters 412 may be sufficient to cause pyrolysis of hydrocarbons. Some of the pyrolysis product may be produced through production wells 206.

[1306] One or more sections may be above and/or below first section 938 (for example, second section 940 and/or third section 942 depicted in FIG. 181). FIG. 182 depicts second section 940 and/or third section 942 adjacent to first section 938. In some embodiments, second section 940 and third section 942 are outside a perimeter defined by the outermost heaters. Some residual heat from first section 938 may transfer to second section 940 and third section 942. In some embodiments, sufficient residual heat is transferred to heat formation fluids to a temperature that allows the fluids to move in second section 940 and/or third section 942 towards production wells 206. Utilization of residual heat from first section 938 to heat hydrocarbons in second section 940 and/or third section 942 may allow hydrocarbons to be produced from the second section and/or third section without direct heating of these sections. A minimal amount of residual heat to second section 940 and/or third section 942 may be superposition heat from heaters 412. Areas of second section 940 and/or third section 942 that are at a distance greater than the spacing between heaters 412 may be heated by residual heat from first section 938. Second section 940 and/or third section 942 may be heated by conductive and/or convective heat from first section 938. A temperature of the sections heated by residual heat may range from 100° C. to 250° C., from 150° C.

to 225° C., or from 175° C. to 200° C. depending on the proximity of heaters 412 to second section 940 and/or third section 942.

[1307] In some embodiments, a solvation fluid is provided to first section 938 through injection wells 602A to solvate hydrocarbons within the first section. In some embodiments, solvation fluid is added to first section 938 after a majority of the condensable hydrocarbons have been produced and the first section has cooled. The solvation fluid may solvate and/or dilute the hydrocarbons in first section 938 to form a mixture of condensable hydrocarbons and solvation fluids. Formation of the mixture may allow for production of hydrocarbons remaining in the first section. Solubilization of hydrocarbons in first section 938 may allow the hydrocarbons to be produced from the first section after heat has been removed from the section. The mixture may be produced through production wells 206A.

[1308] In some embodiments, a solvation fluid is provided to second section 940 and/or third section 942 through injection wells 602B and/or 602C to increase mobilization of hydrocarbons within the second section and/or the third section. The solvation fluid may increase a flow of mobilized hydrocarbons into first section 938. For example, a pressure gradient may be produced between second section 940 and/or third section 942 and first section 938 such that the flow of fluids from the second section and/or the third section to the first section is increased. The solvation fluid may solubilize a portion of the hydrocarbons in second section 940 and/or third section 942 to form a mixture. Solubilization of hydrocarbons in second section 940 and/or third section 942 may allow the hydrocarbons to be produced from the second section and/or third section without direct heating of the sections. In some embodiments, second section 940 and/or third section 942 have been heated from residual heat transferred from first section 938 prior to addition of the solvation fluid. In some embodiments, the solvation fluid is added after second section 940 and/or third section 942 have been heated to a desired temperature by heat from first section 938. In some embodiments, heat from first section 938 and/or heat from the solvation fluid heats section 940 and/or third section 942 to temperatures sufficient to mobilize heavy hydrocarbons in the sections. In some embodiments, section 940 and/or third section 942 are heated to temperatures ranging from 50° C. to 250° C. In some embodiments, temperatures in section 940 and/or third section 942 are sufficient to mobilize heavy hydrocarbons, thus the solvation fluid may mobilize the heavy hydrocarbons by displacing the heavy hydrocarbons with minimal mixing.

[1309] In some embodiments, water and/or emulsified water may be used as a solvation fluid. Water may be injected into a portion of first section 938, second section 940 and/or third section 942 through injection wells 602. Addition of water to at least a selected section of first section 938, second section 940 and/or third section 942 may water saturate a portion of the sections. The water saturated portions of the selected section may be pressurized by known methods and a water/hydrocarbon mixture may be collected using one or more production wells 206.

[1310] In some embodiments, a hydrocarbon formation and/or sections of a hydrocarbon formation may be heated to a selected temperature using a plurality of heaters. Heat from the heaters may transfer from the heaters so that a section of the formation reaches a selected temperature. Treating the hydrocarbon formation with hot water or “near critical” water

may extract and/or solvate hydrocarbons from the formation that have been difficult to produce using other solvent processes and/or heat treatment processes. Not to be bound by theory, near critical water may solubilize organic material (for example, hydrocarbons) normally not soluble in water. The solubilized and/or mobilized hydrocarbons may be produced from the formation. In other embodiments, the formation is treated with critical or near critical carbon dioxide instead of hot water or near critical water.

[1311] In some embodiments, the hydrocarbon formation or one or more section of the formation may be heated (for example, using heaters) to a temperature ranging from about 100° C. to about 240° C., from about 150° C. to about 230° C., or from about 200° C. to about 220° C. In some embodiments, the hydrocarbon formation is an oil shale formation. In some embodiments, temperature within the section may be increased to a pyrolyzation temperature (for example, between about 250° C. and about 400° C.). During heating, hydrocarbons may be transformed into lighter hydrocarbons, water, and gas. The hydrocarbons may include bitumen. In some embodiments, kerogen in an oil formation may be transformed into hydrocarbons, water, and gas. During the transformation at least some the kerogen may be transformed into bitumen. In some embodiments, bitumen may flow into heater and/or production wells and solidify. Solidification of the bitumen may decrease connectivity in the heater and/or decrease production of hydrocarbons. In some embodiments, production of the bitumen is difficult due to the flow properties of bitumen.

[1312] In some embodiments, after heating the section to the desired temperature, the bitumen may be treated with hot water and/or a hot solution of water and solvent (for example, a solution of water and aromatics such as phenol and cresol). Hot water (for example, water at temperatures above 275° C., above 300° C. or above 350° C.) and/or a hot solution (for example, a hot solution of water and one or more aromatic compounds such as phenol and/or cresol compounds) may be injected in the formation (for example, an oil shale formation) or sections of the formation through heater, production, and/or injection wells. Pressure and temperature in the formation and/or the wells may be controlled to maintain the most of the water in a liquid phase. For example, the water temperature may range from about 250° C. to about 300° C. at pressures ranging from 5,000 kPa to 15,000 kPa or from 6,000 kPa to 10,000 kPa. Water at these temperatures at pressure may have a dielectric constant of about 20 and a density of about 0.7 grams per cubic centimeter. In some embodiments, keeping most of the hot water in a liquid phase may allow the water to enter rock matrix of the formation and mobilize the bitumen and/or extract hydrocarbon fluid from the bitumen. In some embodiments, the hydrocarbon fluid and/or hydrocarbons in the hydrocarbon fluid have a viscosity less than the viscosity of the bitumen. The extracted hydrocarbons and/or mobilized bitumen may be produced from the section and/or be moved into other sections with solvating fluids and/or pressurizing fluids. Extraction of hydrocarbons from the bitumen and/or solvation of the bitumen with hot water and/or a hot solution may enhance hydrocarbon recovery from the formation. For example, extraction of bitumen may produce hydrocarbons having an API gravity of at least 10°, at least 15° or at least 20°. The hydrocarbons may have a viscosity of at least 100 centipoise at 15° C. The quality and/or type of the hydrocarbons produced from less heating in combination with hot

water extraction may be improved as compared to the quality of hydrocarbons produced at higher temperatures.

[1313] In certain embodiments, first section 938, second section 940 and/or third section 942 may be treated with hydrocarbons (for example, naphtha, kerosene, diesel, vacuum gas oil, or a mixture thereof). In some embodiments, the hydrocarbons have an aromatic content of at least 1% by weight, at least 5% by weight, at least 10% by weight, at least 20% by weight or at least 25% by weight. Hydrocarbons may be injected into a portion of first section 938, second section 940 and/or third section 942 through injection wells 602. In some embodiments, the hydrocarbons are produced from first section 938 and/or other portions of the formation. In certain embodiments, the hydrocarbons are produced from the formation, treated to remove heavy fractions of hydrocarbons (for example, asphaltenes, hydrocarbons having a boiling point of at least 300° C., of at least 400° C., at least 500° C., or at least 600° C.) and the hydrocarbons are re-introduced into the formation. In some embodiments, one section may be treated with hydrocarbons while another section is treated with water. In some embodiments, water treatment of a section may be alternated with hydrocarbon treatment of the section. In some embodiments, a first portion of hydrocarbons having a relatively high boiling range distribution (for example, kerosene and/or diesel) are introduced in one section. A second portion of hydrocarbons having a relatively low boiling range distribution or hydrocarbons of low economic value (for example, propane) may be introduced into the section after the first portion of hydrocarbons. The introduction of hydrocarbons of different boiling range distributions may enhance recovery of the higher boiling hydrocarbons and more economically valuable hydrocarbons through production wells 206.

[1314] In an embodiment, a blend made from hydrocarbon mixtures produced from first section 938 is used as a solvation fluid. The blend may include about 20% by weight light hydrocarbons (or blending agent) or greater (for example, about 50% by weight or about 80% by weight light hydrocarbons) and about 80% by weight heavy hydrocarbons or less (for example, about 50% by weight or about 20% by weight heavy hydrocarbons). The weight percentage of light hydrocarbons and heavy hydrocarbons may vary depending on, for example, a weight distribution (or API gravity) of light and heavy hydrocarbons, an aromatic content of the hydrocarbons, a relative stability of the blend, or a desired API gravity of the blend. For example, the weight percentage of light hydrocarbons in the blend may be at most 50% by weight or at most 20% by weight. In certain embodiments, the weight percentage of light hydrocarbons may be selected to mix the least amount of light hydrocarbons with heavy hydrocarbons that produces a blend with a desired density or viscosity.

[1315] In some embodiments, polymers and/or monomers may be used as solvation fluids. Polymers and/or monomers may solvate and/or drive hydrocarbons to allow mobilization of the hydrocarbons towards one or more production wells. The polymer and/or monomer may reduce the mobility of a water phase in pores of the hydrocarbon containing formation. The reduction of water mobility may allow the hydrocarbons to be more easily mobilized through the hydrocarbon containing formation. Polymers that may be used include, but are not limited to, polyacrylamides, partially hydrolyzed polyacrylamide, polyacrylates, ethylenic copolymers, biopolymers, carboxymethylcellulose, polyvinyl alcohol, polystyrene sulfonates, polyvinylpyrrolidone, AMPS

(2-acrylamide-2-methyl propane sulfonate), or combinations thereof. Examples of ethylenic copolymers include copolymers of acrylic acid and acrylamide, acrylic acid and lauryl acrylate, lauryl acrylate and acrylamide. Examples of biopolymers include xanthan gum and guar gum. In some embodiments, polymers may be crosslinked in situ in the hydrocarbon containing formation. In other embodiments, polymers may be generated in situ in the hydrocarbon containing formation. Polymers and polymer preparations for use in oil recovery are described in U.S. Pat. No. 6,439,308 to Wang; U.S. Pat. No. 6,417,268 to Zhang et al.; U.S. Pat. No. 5,654,261 to Smith; U.S. Pat. No. 5,284,206 to Surles et al.; U.S. Pat. No. 5,199,490 to Surles et al.; and U.S. Pat. No. 5,103,909 to Morgenthaler et al., each of which is incorporated by reference as if fully set forth herein.

[1316] In some embodiments, the solvation fluid includes one or more nonionic additives (for example, alcohols, ethoxylated alcohols, nonionic surfactants and/or sugar based esters). In some embodiments, the solvation fluid includes one or more anionic surfactants (for example, sulfates, sulfonates, ethoxylated sulfates, and/or phosphates).

[1317] In some embodiments, the solvation fluid includes carbon disulfide. Hydrogen sulfide, in addition to other sulfur compounds produced from the formation, may be converted to carbon disulfide using known methods. Suitable methods may include oxidizing sulfur compounds to sulfur and/or sulfur dioxide, and reacting sulfur and/or sulfur dioxide with carbon and/or a carbon containing compound to form carbon disulfide. The conversion of the sulfur compounds to carbon disulfide and the use of the carbon disulfide for oil recovery are described in U.S. Pat. No. 7,426,959 to Wang et al., which is incorporated by reference as if fully set forth herein. The carbon disulfide may be introduced into first section 938, second section 940 and/or third section 942 as a solvation fluid.

[1318] In some embodiments, the solvation fluid is a hydrocarbon compound that is capable of donating a hydrogen atom to the formation fluids. In some embodiments, the solvation fluid is capable of donating hydrogen to at least a portion of the formation fluid, thus forming a mixture of solvating fluid and dehydrogenated solvating fluid mixture. The solvating fluid/dehydrogenated solvating fluid mixture may enhance solvation and/or dissolution of a greater portion of the formation fluids as compared to the initial solvation fluid. Examples of such hydrogen donating solvating fluids include, but are not limited to, tetralin, alkyl substituted tetralin, tetrahydroquinoline, alkyl substituted hydroquinoline, 1,2-dihydronaphthalene, a distillate cut having at least 40% by weight naphthenic aromatic compounds, or mixtures thereof. In some embodiments, the hydrogen donating hydrocarbon compound is tetralin.

[1319] In some embodiments, first section 938, second section 940 and/or third section 942 are heated to a temperature ranging from 175° C. to 350° C. in the presence of the hydrogen donating solvating fluid. At these temperatures at least a portion of the formation fluids may be hydrogenated by hydrogen donated from the hydrogen donating solvation fluid. In some embodiments, the minerals in the formation act as a catalyst for the hydrogenation process so that elevated formation temperatures may not be necessary. Hydrogenation of at least a portion of the formation fluids may upgrade a portion of the formation fluids and form a mixture of upgraded fluids and formation fluids. The mixture may have a reduced viscosity compared to the initial formation fluids.

In situ upgrading and the resulting reduction in viscosity may facilitate mobilization and/or recovery of the formation fluids. In situ upgrading products that may be separated from the formation fluids at the surface include, but are not limited to, naphtha, vacuum gas oil, distillate, kerosene, and/or diesel. Dehydrogenation of at least a portion of the hydrogen donating solvent may form a mixture that has increased polarity as compared to the initial hydrogen donating solvent. The increased polarity may enhance solvation or dissolution of a portion of the formation fluids and facilitate production and/or mobilization of the fluids to production wells 206.

[1320] In some embodiments, the hydrogen donating hydrocarbon compound is heated in a surface facility prior to being introduced into first section 938, second section 940 and/or third section 942. For example, the hydrogen donating hydrocarbon compound may be heated to a temperature ranging from 100° C. to about 180° C., 120° C. to about 170° C., or from about 130 to 160° C. Heat from the hot hydrogen donating hydrocarbon compound may facilitate mobilization, recovery and/or hydrogenation of fluids from first section 938, second section 940 and/or third section 942.

[1321] In some embodiments, a pressurizing fluid is provided in second section 940 and/or third section 942 (for example, through injection wells 602B, 602C) to increase mobilization of hydrocarbons within the sections. In some embodiments, a pressurizing fluid is provided to second section 940 and/or third section 942 in combination with the solvation fluid to increase mobility of hydrocarbons within the formation. The pressurizing fluid may include gases such as carbon dioxide, nitrogen, steam, methane, and/or mixtures thereof. In some embodiments, fluids produced from the formation (for example, combustion gases, heater exhaust gases, or produced formation fluids) may be used as pressurizing fluid.

[1322] Providing a pressurizing fluid may increase a shear rate applied to hydrocarbon fluids in the formation and decrease the viscosity of non-Newtonian hydrocarbon fluids within the formation. In some embodiments, pressurizing fluid is provided to the selected section before significant heating of the formation. Pressurizing fluid injection may increase the volume of the formation available for production. Pressurizing fluid injection may increase a ratio of energy output of the formation (energy content of products produced from the formation) to energy input into the formation (energy costs for treating the formation).

[1323] Providing the pressurizing fluid may increase a pressure in a selected section of the formation. The pressure in the selected section may be maintained below a selected pressure. For example, the pressure may be maintained below about 150 bars absolute, about 100 bars absolute, or about 50 bars absolute. In some embodiments, the pressure may be maintained below about 35 bars absolute. Pressure may be varied depending on a number of factors (for example, desired production rate or an initial viscosity of tar in the formation). Injection of a gas into the formation may result in a viscosity reduction of some of the formation fluids.

[1324] The pressurizing fluid may enhance the pressure gradient in the formation to flow mobilized hydrocarbons into first section 938. In certain embodiments, the production of fluids from first section 938 allows the pressure in second section 940 and/or third section 942 to remain below a selected pressure (for example, a pressure below which fracturing of the overburden and/or the underburden may occur). In some embodiments, second section 940 and/or third sec-

tion 942 have been heated by heat transfer from first section 938 prior to addition of the pressurizing fluid. In some embodiments, the pressurizing fluid is added after second section 940 and/or third section 942 have been heated to a desired temperature by residual heat from first section 938.

[1325] In some embodiments, pressure is maintained by controlling flow of the pressurizing fluid into the selected section. In other embodiments, the pressure is controlled by varying a location or locations for injecting the pressurizing fluid. In other embodiments, pressure is maintained by controlling a pressure and/or production rate at production wells 206A, 206B and/or 206C. In some embodiments, the pressurized fluid (for example, carbon dioxide) is separated from the produced fluids and re-introduced into the formation. After production has been stopped, the fluid may be sequestered in the formation.

[1326] In certain embodiments, formation fluid is produced from first section 938, second section 940 and/or third section 942. The formation fluid may be produced through production wells 206A, 206B and/or 206C. The formation fluid produced from second section 940 and/or third section 942 may include solvation fluid; hydrocarbons from first section 938, second section 940 and/or third section 942; and/or mixtures thereof.

[1327] Producing fluid from production wells in first section 938 may lower the average pressure in the formation by forming an expansion volume for mobilized fluids in adjacent sections of the formation. Producing fluid from production wells 206 in the first section 938 may establish a pressure gradient in the formation that draws mobilized fluid from second section 940 and/or third section 942 into the first section.

[1328] Hydrocarbons may be produced from first section 938, second section 940 and/or third section 942 such that at least about 30%, at least about 40%, at least about 50%, at least about 60% or at least about 70% by volume of the initial mass of hydrocarbons in the formation are produced. In certain embodiments, additional hydrocarbons may be produced from the formation such that at least about 60%, at least about 70%, or at least about 80% by volume of the initial volume of hydrocarbons in the sections is produced from the formation through the addition of solvation fluid.

[1329] Fluids produced from production wells described herein may be transported through conduits (pipelines) between the formation and treatment facilities or refineries. The produced fluids may be transported through a pipeline to another location for further transportation (for example, the fluids can be transported to a facility at a river or a coast through the pipeline where the fluids can be further transported by tanker to a processing plant or refinery). Incorporation of selected solvation fluids and/or other produced fluids (for example, aromatic hydrocarbons) in the produced formation fluid may stabilize the formation fluid during transportation. In some embodiments, the solvation fluid is separated from the formation fluids after transportation to treatment facilities. In some embodiments, at least a portion of the solvation fluid is separated from the formation fluids prior to transportation. In some embodiments, the fluids produced prior to solvent treatment include heavy hydrocarbons.

[1330] In some embodiments, the produced fluids may include at least 85% hydrocarbon liquids by volume and at most 15% gases by volume, at least 90% hydrocarbon liquids by volume and at most 10% gases by volume, or at least 95% hydrocarbon liquids by volume and at most 5% gases by

volume. In some embodiments, the mixture produced after solvent and/or pressure treatment includes solvation fluids, gases, bitumen, visbroken fluids, pyrolyzed fluids, or combinations thereof. The mixture may be separated into heavy hydrocarbon liquids, solvation fluid and/or gases. In some embodiments the heavy hydrocarbon liquids, solvation fluid and/or pressuring fluid (for example, carbon dioxide) are re-injected in another section of the formation.

[1331] The heavy hydrocarbon liquids separated from the mixture may have an API gravity of between 10° and 25°, between 15° and 24°, or between 19° and 23°. In some embodiments, the separated hydrocarbon liquids may have an API gravity between 19° and 25°, between 20° and 24°, or between 21° and 23°. A viscosity of the separated hydrocarbon liquids may be at most 350 cp at 5° C. A P-value of the separated hydrocarbon liquids may be at least 1.1, at least 1.5 or at least 2.0. The separated hydrocarbon liquids may have a bromine number of at most 3% and/or a CAPP number of at most 2%. In some embodiments, the separated hydrocarbon liquids have an API gravity between 19° and 25°, a viscosity ranging at most 350 cp at 5° C., a P-value of at least 1.1, a CAPP number of at most 2% as 1-decene equivalent, and/or a bromine number of at most 2%.

[1332] After an in situ process, energy recovery, remediation, and/or sequestration of carbon dioxide or other fluids in the treated area; the treatment area may still be at an elevated temperature. Sulfur may be introduced into the formation to act as a drive fluid to remove remaining formation fluid from the formation. The sulfur may be introduced through outermost wellbores in the formation. The wellbores may be injection wells, production wells, monitor wells, heater wells, barrier wells, or other types of wells that are converted to use as sulfur injection wells. The sulfur may be used to drive fluid inwards towards production wells in the pattern of wells used during the in situ heat treatment process. The wells used as production wells for sulfur may be production wells, heater wells, injection wells, monitor wells, or other types of wells converted for use as sulfur production wells.

[1333] In some embodiments, sulfur may be introduced in the treatment area from an outermost set of wells. Formation fluid may be produced from a first inward set of wellbores until substantially only sulfur is produced from the first inward set of wells. The first inward set of wells may be converted to injection wells. Sulfur may be introduced in the first inward set of wells to drive remaining formation fluid towards a second inward set of wells. The pattern may be continued until sulfur has been introduced into all of the treatment area. In some embodiments, a line drive may be used for introducing the sulfur into the treatment area.

[1334] In some embodiments, molten sulfur may be injected into the treatment area. The molten sulfur may act as a displacement agent that moves and/or entrains remaining fluid in the treatment area. The molten sulfur may be injected into the formation from selected wells. The sulfur may be at a temperature near a melting point of sulfur so that the sulfur has a relatively low viscosity. In some embodiments, the formation may be at a temperature above the boiling point of sulfur. Sulfur may be introduced into the formation as a gas or as a liquid.

[1335] Sulfur may be introduced into the formation until substantially only sulfur is produced from the last sulfur production well or production wells. When substantially only sulfur is produced from the last sulfur production well or production wells, introduction of additional sulfur may be

stopped, and the production from the production well or production wells may be stopped. Sulfur in the formation may be allowed to remain in the formation and solidify.

[1336] Some hydrocarbon containing formations, such as oil shale formations, may include nahcolite, trona, dawsonite, and/or other minerals within the formation. In some embodiments, nahcolite is contained in partially unleached or unleached portions of the formation. Unleached portions of the formation are parts of the formation where minerals have not been removed by groundwater in the formation. For example, in the Piceance basin in Colorado, U.S.A., unleached oil shale is found below a depth of about 500 m below grade. Deep unleached oil shale formations in the Piceance basin center tend to be relatively rich in hydrocarbons. For example, about 0.10 liters to about 0.15 liters of oil per kilogram (L/kg) of oil shale may be producible from an unleached oil shale formation.

[1337] Nahcolite is a mineral that includes sodium bicarbonate (NaHCO_3). Nahcolite may be found in formations in the Green River lakebeds in Colorado, U.S.A. In some embodiments, at least about 5 weight %, at least about 10 weight %, or at least about 20 weight % nahcolite may be present in the formation. Dawsonite is a mineral that includes sodium aluminum carbonate ($\text{NaAl}(\text{CO}_3)(\text{OH})_2$). Dawsonite is typically present in the formation at weight percents greater than about 2 weight % or, in some embodiments, greater than about 5 weight %. Nahcolite and/or dawsonite may dissociate at temperatures used in an in situ heat treatment process. The dissociation is strongly endothermic and may produce large amounts of carbon dioxide.

[1338] Nahcolite and/or dawsonite may be solution mined prior to, during, and/or following treatment of the formation in situ to avoid dissociation reactions and/or to obtain desired chemical compounds. In certain embodiments, hot water or steam is used to dissolve nahcolite in situ to form an aqueous sodium bicarbonate solution before the in situ heat treatment process is used to process hydrocarbons in the formation. Nahcolite may form sodium ions (Na^+) and bicarbonate ions (HCO_3^-) in aqueous solution. The solution may be produced from the formation through production wells, thus avoiding dissociation reactions during the in situ heat treatment process. In some embodiments, dawsonite is thermally decomposed to alumina during the in situ heat treatment process for treating hydrocarbons in the formation. The alumina is solution mined after completion of the in situ heat treatment process.

[1339] Production wells and/or injection wells used for solution mining and/or for in situ heat treatment processes may include smart well technology. The smart well technology allows the first fluid to be introduced at a desired zone in the formation. The smart well technology allows the second fluid to be removed from a desired zone of the formation.

[1340] Formations that include nahcolite and/or dawsonite may be treated using the in situ heat treatment process. A perimeter barrier may be formed around the portion of the formation to be treated. The perimeter barrier may inhibit migration of water into the treatment area. During solution mining and/or the in situ heat treatment process, the perimeter barrier may inhibit migration of dissolved minerals and formation fluid from the treatment area. During initial heating, a portion of the formation to be treated may be raised to a temperature below the dissociation temperature of the nahcolite. The temperature may be at most about 90° C., or in some embodiments, at most about 80° C. The temperature

may be any temperature that increases the solvation rate of nahcolite in water, but is also below a temperature at which nahcolite dissociates (above about 95° C. at atmospheric pressure).

[1341] A first fluid may be injected into the heated portion. The first fluid may include water, brine, steam, or other fluids that form a solution with nahcolite and/or dawsonite. The first fluid may be at an increased temperature, for example, about 90° C., about 95° C., or about 100° C. The increased temperature may be similar to the temperature of the portion of the formation.

[1342] In some embodiments, the first fluid is injected at an increased temperature into a portion of the formation that has not been heated by heat sources. The increased temperature may be a temperature below a boiling point of the first fluid, for example, about 90° C. for water. Providing the first fluid at an increased temperature increases a temperature of a portion of the formation. In certain embodiments, additional heat may be provided from one or more heat sources in the formation during and/or after injection of the first fluid.

[1343] In other embodiments, the first fluid is or includes steam. The steam may be produced by forming steam in a previously heated portion of the formation (for example, by passing water through u-shaped wellbores that have been used to heat the formation), by heat exchange with fluids produced from the formation, and/or by generating steam in standard steam production facilities. In some embodiments, the first fluid may be fluid introduced directly into a hot portion of the portion and produced from the hot portion of the formation. The first fluid may then be used as the first fluid for solution mining.

[1344] In some embodiments, heat from a hot previously treated portion of the formation is used to heat water, brine, and/or steam used for solution mining a new portion of the formation. Heat transfer fluid may be introduced into the hot previously treated portion of the formation. The heat transfer fluid may be water, steam, carbon dioxide, and/or other fluids. Heat may transfer from the hot formation to the heat transfer fluid. The heat transfer fluid is produced from the formation through production wells. The heat transfer fluid is sent to a heat exchanger. The heat exchanger may heat water, brine, and/or steam used as the first fluid to solution mine the new portion of the formation. The heat transfer fluid may be reintroduced into the heated portion of the formation to produce additional hot heat transfer fluid. In some embodiments, heat transfer fluid produced from the formation is treated to remove hydrocarbons or other materials before being reintroduced into the formation as part of a remediation process for the heated portion of the formation.

[1345] Steam injected for solution mining may have a temperature below the pyrolysis temperature of hydrocarbons in the formation. Injected steam may be at a temperature below 250° C., below 300° C., or below 400° C. The injected steam may be at a temperature of at least 150° C., at least 135° C., or at least 125° C. Injecting steam at pyrolysis temperatures may cause problems as hydrocarbons pyrolyze and hydrocarbon fines mix with the steam. The mixture of fines and steam may reduce permeability and/or cause plugging of production wells and the formation. Thus, the injected steam temperature is selected to inhibit plugging of the formation and/or wells in the formation.

[1346] The temperature of the first fluid may be varied during the solution mining process. As the solution mining progresses and the nahcolite being solution mined is farther

away from the injection point, the first fluid temperature may be increased so that steam and/or water that reaches the nahcolite to be solution mined is at an elevated temperature below the dissociation temperature of the nahcolite. The steam and/or water that reaches the nahcolite is also at a temperature below a temperature that promotes plugging of the formation and/or wells in the formation (for example, the pyrolysis temperature of hydrocarbons in the formation).

[1347] A second fluid may be produced from the formation following injection of the first fluid into the formation. The second fluid may include material dissolved in the first fluid. For example, the second fluid may include carbonic acid or other hydrated carbonate compounds formed from the dissolution of nahcolite in the first fluid. The second fluid may also include minerals and/or metals. The minerals and/or metals may include sodium, aluminum, phosphorus, and other elements.

[1348] Solution mining the formation before the in situ heat treatment process allows initial heating of the formation to be provided by heat transfer from the first fluid used during solution mining. Solution mining nahcolite or other minerals that decompose or dissociate by means of endothermic reactions before the in situ heat treatment process avoids having energy supplied to heat the formation being used to support these endothermic reactions. Solution mining allows for production of minerals with commercial value. Removing nahcolite or other minerals before the in situ heat treatment process removes mass from the formation. Thus, less mass is present in the formation that needs to be heated to higher temperatures and heating the formation to higher temperatures may be achieved more quickly and/or more efficiently. Removing mass from the formation also may increase the permeability of the formation. Increasing the permeability may reduce the number of production wells needed for the in situ heat treatment process. In certain embodiments, solution mining before the in situ heat treatment process reduces the time delay between startup of heating of the formation and production of hydrocarbons by two years or more.

[1349] FIG. 183 depicts an embodiment of solution mining well 944. Solution mining well 944 may include insulated portion 926, input 946, packer 948, and return 950. Insulated portion 926 may be adjacent to overburden 400 of the formation. In some embodiments, insulated portion 926 is low conductivity cement. The cement may be low density, low conductivity vermiculite cement or foam cement. Input 946 may direct the first fluid to treatment area 730. Perforations or other types of openings in input 946 allow the first fluid to contact formation material in treatment area 730. Packer 948 may be a bottom seal for input 946. First fluid passes through input 946 into the formation. First fluid dissolves minerals and becomes second fluid. The second fluid may be denser than the first fluid. An entrance into return 950 is typically located below the perforations or openings that allow the first fluid to enter the formation. Second fluid flows to return 950. The second fluid is removed from the formation through return 950.

[1350] FIG. 184 depicts a representation of an embodiment of solution mining well 944. Solution mining well 944 may include input 946 and return 950 in casing 952. Input 946 and/or return 950 may be coiled tubing.

[1351] FIG. 185 depicts a representation of an embodiment of solution mining well 944. Insulating portions 926 may surround return 950. Input 946 may be positioned in return 950. In some embodiments, input 946 may introduce the first

fluid into the treatment area below the entry point into return 950. In some embodiments, crossovers may be used to direct first fluid flow and second fluid flow so that first fluid is introduced into the formation from input 946 above the entry point of second fluid into return 950.

[1352] FIG. 186 depicts an elevational view of an embodiment of wells used for solution mining and/or for an in situ heat treatment process. Solution mining wells 944 may be placed in the formation in an equilateral triangle pattern. In some embodiments, the spacing between solution mining wells 944 may be about 36 m. Other spacings may be used. Heat sources 202 may also be placed in an equilateral triangle pattern. Solution mining wells 944 substitute for certain heat sources of the pattern. In the shown embodiment, the spacing between heat sources 202 is about 9 m. The ratio of solution mining well spacing to heat source spacing is 4. Other ratios may be used if desired. After solution mining is complete, solution mining wells 944 may be used as production wells for the in situ heat treatment process.

[1353] In some formations, a portion of the formation with unleached minerals may be below a leached portion of the formation. The unleached portion may be thick and substantially impermeable. A treatment area may be formed in the unleached portion. Unleached portion of the formation to the sides, above and/or below the treatment area may be used as barriers to fluid flow into and out of the treatment area. A first treatment area may be solution mined to remove minerals, increase permeability in the treatment area, and/or increase the richness of the hydrocarbons in the treatment area. After solution mining the first treatment area, in situ heat treatment may be used to treat a second treatment area. In some embodiments, the second treatment area is the same as the first treatment area. In some embodiments, the second treatment has a smaller volume than the first treatment area so that heat provided by outermost heat sources to the formation do not raise the temperature of unleached portions of the formation to the dissociation temperature of the minerals in the unleached portions.

[1354] In some embodiments, a leached or partially leached portion of the formation above an unleached portion of the formation may include significant amounts of hydrocarbon materials. An in situ heating process may be used to produce hydrocarbon fluids from the unleached portions and the leached or partially leached portions of the formation. FIG. 187 depicts a representation of a formation with unleached zone 954 below leached zone 956. Unleached zone 954 may have an initial permeability before solution mining of less than 0.1 millidarcy. Solution mining wells 944 may be placed in the formation. Solution mining wells 944 may include smart well technology that allows the position of first fluid entrance into the formation and second flow entrance into the solution mining wells to be changed. Solution mining wells 944 may be used to form first treatment area 730' in unleached zone 954. Unleached zone 954 may initially be substantially impermeable. Unleached portions of the formation may form a top barrier and side barriers around first treatment area 730'. After solution mining first treatment area 730', the portions of solution mining wells 944 adjacent to the first treatment area may be converted to production wells and/or heater wells.

[1355] Heat sources 202 in first treatment area 730' may be used to heat the first treatment area to pyrolysis temperatures. In some embodiments, one or more heat sources 202 are placed in the formation before first treatment area 730' is

solution mined. The heat sources may be used to provide initial heating to the formation to raise the temperature of the formation and/or to test the functionality of the heat sources. In some embodiments, one or more heat sources are installed during solution mining of the first treatment area, or after solution mining is completed. After solution mining, heat sources 202 may be used to raise the temperature of at least a portion of first treatment area 730' above the pyrolysis and/or mobilization temperature of hydrocarbons in the formation to result in the generation of mobile hydrocarbons in the first treatment area.

[1356] Barrier wells 200 may be introduced into the formation. Ends of barrier wells 200 may extend into and terminate in unleached zone 954. Unleached zone 954 may be impermeable. In some embodiments, barrier wells 200 are freeze wells. Barrier wells 200 may be used to form a barrier to fluid flow into or out of unleached zone 956. Barrier wells 200, overburden 400, and the unleached material above first treatment area 730' may define second treatment area 730". In some embodiments, a first fluid may be introduced into second treatment area 730" through solution mining wells 944 to raise the initial temperature of the formation in second treatment area 730" and remove any residual soluble minerals from the second treatment area. In some embodiments, the top barrier above first treatment area 730' may be solution mined to remove minerals and combine first treatment area 730' and second treatment area 730" into one treatment area. After solution mining, heat sources may be activated to heat the treatment area to pyrolysis temperatures.

[1357] FIG. 188 depicts an embodiment for solution mining the formation. Barrier 958 (for example, a frozen barrier and/or a grout barrier) may be formed around a perimeter of treatment area 730 of the formation. The footprint defined by the barrier may have any desired shape such as circular, square, rectangular, polygonal, or irregular shape. Barrier 958 may be any barrier formed to inhibit the flow of fluid into or out of treatment area 730. For example, barrier 958 may include one or more freeze wells that inhibit water flow through the barrier. Barrier 958 may be formed using one or more barrier wells 200. Formation of barrier 958 may be monitored using monitor wells 960 and/or by monitoring devices placed in barrier wells 200.

[1358] Water inside treatment area 730 may be pumped out of the treatment area through injection wells 602 and/or production wells 206. In certain embodiments, injection wells 602 are used as production wells 206 and vice versa (the wells are used as both injection wells and production wells). Water may be pumped out until a production rate of water is low or stops.

[1359] Heat may be provided to treatment area 730 from heat sources 202. Heat sources may be operated at temperatures that do not result in the pyrolysis of hydrocarbons in the formation adjacent to the heat sources. In some embodiments, treatment area 730 is heated to a temperature from about 90° C. to about 120° C. (for example, a temperature of about 90° C., 95° C., 100° C., 110° C., or 120° C.). In certain embodiments, heat is provided to treatment area 730 from the first fluid injected into the formation. The first fluid may be injected at a temperature from about 90° C. to about 120° C. (for example, a temperature of about 90° C., 95° C., 100° C., 110° C., or 120° C.). In some embodiments, heat sources 202 are installed in treatment area 730 after the treatment area is solution mined. In some embodiments, some heat is provided from heaters placed in injection wells 602 and/or production

wells 206. A temperature of treatment area 730 may be monitored using temperature measurement devices placed in monitoring wells 960 and/or temperature measurement devices in injection wells 602, production wells 206, and/or heat sources 202.

[1360] The first fluid is injected through one or more injection wells 602. In some embodiments, the first fluid is hot water. The first fluid may mix and/or combine with non-hydrocarbon material that is soluble in the first fluid, such as nahcolite, to produce a second fluid. The second fluid may be removed from the treatment area through injection wells 602, production wells 206, and/or heat sources 202. Injection wells 602, production wells 206, and/or heat sources 202 may be heated during removal of the second fluid. Heating one or more wells during removal of the second fluid may maintain the temperature of the fluid during removal of the fluid from the treatment area above a desired value. After producing a desired amount of the soluble non-hydrocarbon material from treatment area 730, solution remaining within the treatment area may be removed from the treatment area through injection wells 602, production wells 206, and/or heat sources 202. The desired amount of the soluble non-hydrocarbon material may be less than half of the soluble non-hydrocarbon material, a majority of the soluble non-hydrocarbon material, substantially all of the soluble non-hydrocarbon material, or all of the soluble non-hydrocarbon material. Removing soluble non-hydrocarbon material may produce a relatively high permeability treatment area 730.

[1361] Hydrocarbons within treatment area 730 may be pyrolyzed and/or produced using the in situ heat treatment process following removal of soluble non-hydrocarbon materials. The relatively high permeability treatment area allows for easy movement of hydrocarbon fluids in the formation during in situ heat treatment processing. The relatively high permeability treatment area provides an enhanced collection area for pyrolyzed and mobilized fluids in the formation. During the in situ heat treatment process, heat may be provided to treatment area 730 from heat sources 202. A mixture of hydrocarbons may be produced from the formation through production wells 206 and/or heat sources 202. In certain embodiments, injection wells 602 are used as either production wells and/or heater wells during the in situ heat treatment process.

[1362] In some embodiments, a controlled amount of oxidant (for example, air and/or oxygen) is provided to treatment area 730 at or near heat sources 202 when a temperature in the formation is above a temperature sufficient to support oxidation of hydrocarbons. At such a temperature, the oxidant reacts with the hydrocarbons to provide heat in addition to heat provided by electrical heaters in heat sources 202. The controlled amount of oxidant may facilitate oxidation of hydrocarbons in the formation to provide additional heat for pyrolyzing hydrocarbons in the formation. The oxidant may more easily flow through treatment area 730 because of the increased permeability of the treatment area after removal of the non-hydrocarbon materials. The oxidant may be provided in a controlled manner to control the heating of the formation. The amount of oxidant provided is controlled so that uncontrolled heating of the formation is avoided. Excess oxidant and combustion products may flow to production wells in treatment area 730.

[1363] Following the in situ heat treatment process, treatment area 730 may be cooled by introducing water to produce steam from the hot portion of the formation. Introduction of

water to produce steam may vaporize some hydrocarbons remaining in the formation. Water may be injected through injection wells 602. The injected water may cool the formation. The remaining hydrocarbons and generated steam may be produced through production wells 206 and/or heat sources 202. Treatment area 730 may be cooled to a temperature near the boiling point of water. The steam produced from the formation may be used to heat a first fluid used to solution mine another portion of the formation.

[1364] Treatment area 730 may be further cooled to a temperature at which water will condense in the formation. Water and/or solvent may be introduced into and be removed from the treatment area. Removing the condensed water and/or solvent from treatment area 730 may remove any additional soluble material remaining in the treatment area. The water and/or solvent may entrain non-soluble fluid present in the formation. Fluid may be pumped out of treatment area 730 through production well 206 and/or heat sources 202. The injection and removal of water and/or solvent may be repeated until a desired water quality within treatment area 730 is achieved. Water quality may be measured at the injection wells, heat sources 202, and/or production wells. The water quality may substantially match or exceed the water quality of treatment area 730 prior to treatment.

[1365] In some embodiments, treatment area 730 may include a leached zone located above an unleached zone. The leached zone may have been leached naturally and/or by a separate leaching process. In certain embodiments, the unleached zone may be at a depth of at least about 500 m. A thickness of the unleached zone may be between about 100 m and about 500 m. However, the depth and thickness of the unleached zone may vary depending on, for example, a location of treatment area 730 and/or the type of formation. In certain embodiments, the first fluid is injected into the unleached zone below the leached zone. Heat may also be provided into the unleached zone.

[1366] In certain embodiments, a section of a formation may be left untreated by solution mining and/or unleached. The unleached section may be proximate a selected section of the formation that has been leached and/or solution mined by providing the first fluid as described above. The unleached section may inhibit the flow of water into the selected section. In some embodiments, more than one unleached section may be proximate a selected section.

[1367] Nahcolite may be present in the formation in layers or beds. Prior to solution mining, such layers may have little or no permeability. In certain embodiments, solution mining layered or bedded nahcolite from the formation causes vertical shifting in the formation. FIG. 189 depicts an embodiment of a formation with nahcolite layers in the formation below overburden 400 and before solution mining nahcolite from the formation. Hydrocarbon layers 388A have substantially no nahcolite and hydrocarbon layers 388B have nahcolite. FIG. 190 depicts the formation of FIG. 189 after the nahcolite has been solution mined. Layers 388B have collapsed due to the removal of the nahcolite from the layers. The collapsing of layers 388B causes compaction of the layers and vertical shifting of the formation. The hydrocarbon richness of layers 388B is increased after compaction of the layers. In addition, the permeability of layers 388B may remain relatively high after compaction due to removal of the nahcolite. The permeability may be more than 5 darcy, more than 1 darcy, or more than 0.5 darcy after vertical shifting. The permeability may provide fluid flow paths to production wells when the forma-

tion is treated using an in situ heat treatment process. The increased permeability may allow for a large spacing between production wells. Distances between production wells for the in situ heat treatment system after solution mining may be greater than 10 m, greater than 20 m, or greater than 30 meters. Heater wells may be placed in the formation after removal of nahcolite and the subsequent vertical shifting. Forming heater wellbores and/or installing heaters in the formation after the vertical shifting protects the heaters from being damaged due to the vertical shifting.

[1368] In certain embodiments, removing nahcolite from the formation interconnects two or more wells in the formation. Removing nahcolite from zones in the formation may increase the permeability in the zones. Some zones may have more nahcolite than others and become more permeable as the nahcolite is removed. At a certain time, zones with the increased permeability may interconnect two or more wells (for example, injection wells or production wells) in the formation.

[1369] FIG. 191 depicts an embodiment of two injection wells interconnected by a zone that has been solution mined to remove nahcolite from the zone. Solution mining wells 944 are used to solution mine hydrocarbon layer 388, which contains nahcolite. During the initial portion of the solution mining process, solution mining wells 944 are used to inject water and/or other fluids, and to produce dissolved nahcolite fluids from the formation. Each solution mining well 944 is used to inject water and produce fluid from a near wellbore region as the permeability of hydrocarbon layer is not sufficient to allow fluid to flow between the injection wells. In certain embodiments, zone 962 has more nahcolite than other portions of hydrocarbon layer 388. With increased nahcolite removal from zone 962, the permeability of the zone may increase. The permeability increases from the wellbores outwards as nahcolite is removed from zone 962. At some point during solution mining of the formation, the permeability of zone 962 increases to allow solution mining wells 944 to become interconnected such that fluid will flow between the wells. At this time, one solution mining well 944 may be used to inject water while the other solution mining well is used to produce fluids from the formation in a continuous process. Injecting in one well and producing from a second well may be more economical and more efficient in removing nahcolite, as compared to injecting and producing through the same well. In some embodiments, additional wells may be drilled into zone 962 and/or hydrocarbon layer 388 in addition to solution mining wells 944. The additional wells may be used to circulate additional water and/or to produce fluids from the formation. The wells may later be used as heater wells and/or production wells for the in situ heat treatment process treatment of hydrocarbon layer 388.

[1370] In some embodiments, a treatment area has nahcolite beds above and/or below the treatment area. The nahcolite beds may be relatively thin (for example, about 5 m to about 10 m in thickness). In an embodiment, the nahcolite beds are solution mined using horizontal solution mining wells in the nahcolite beds. The nahcolite beds may be solution mined in a short amount of time (for example, in less than 6 months). After solution mining of the nahcolite beds, the treatment area and the nahcolite beds may be heated using one or more heaters. The heaters may be placed either vertically, horizontally, or at other angles within the treatment area and the nahcolite beds. The nahcolite beds and the treatment area may then undergo the in situ heat treatment process.

[1371] In some embodiments, the solution mining wells in the nahcolite beds are converted to production wells. The production wells may be used to produce fluids during the in situ heat treatment process. Production wells in the nahcolite bed above the treatment area may be used to produce vapors or gas (for example, gas hydrocarbons) from the formation. Production wells in the nahcolite bed below the treatment area may be used to produce liquids (for example, liquid hydrocarbons) from the formation.

[1372] FIG. 192 depicts a representation of an embodiment for treating a portion of a formation having hydrocarbon containing layer 388 between upper nahcolite bed 964 and lower nahcolite bed 964'. In an embodiment, nahcolite beds 964, 964' have thicknesses of about 5 m and include relatively large amounts of nahcolite (for example, over about 50 weight percent nahcolite). In the embodiment, hydrocarbon containing layer 388 is at a depth of over 595 meters below the surface, has a thickness of 40 m or more and has oil shale with an average richness of over 100 liters per metric ton. Hydrocarbon containing layer 388 may contain relatively little nahcolite, though the hydrocarbon containing layer may contain some seams of nahcolite typically with thicknesses less than 3 m.

[1373] Solution mining wells 944 may be formed in nahcolite beds 964, 964' (i.e., into and out of the page as depicted in FIG. 192). FIG. 193 depicts a representation of a portion of the formation that is orthogonal to the formation depicted in FIG. 192 and passes through one of solution mining wells 944 in nahcolite bed 964. Solution mining wells 944 may be spaced apart by 25 m or more. Hot water and/or steam may be circulated into the formation from solution mining wells 944 to dissolve nahcolite in nahcolite beds 964, 964'. Dissolved nahcolite may be produced from the formation through solution mining wells 944. After completion of solution mining, production liners may be installed in one or more of the solution mining wells 944 and the solution mining wells may be converted to production wells for an in situ heat treatment process used to produce hydrocarbons from hydrocarbon containing layer 388.

[1374] Before, during or after solution mining of nahcolite beds 964, 964', heater wellbores 490 may be formed in the formation in a pattern (for example, in a triangular pattern as depicted in FIG. 193 with wellbores going into and out of the page). As depicted in FIG. 192, portions of heater wellbores 490 may pass through nahcolite bed 964. Portions of heater wellbores 490 may pass into or through nahcolite bed 964'. Heaters wellbores 490 may be oriented at an angle (as depicted in FIG. 192), oriented vertically, or oriented substantially horizontally if the nahcolite layers dip. Heaters may be placed in heater wellbores 490. Heating sections of the heaters may provide heat to hydrocarbon containing layer 388. The wellbore pattern may allow superposition of heat from the heaters to raise the temperature of hydrocarbon containing layer 388 to a desired temperature in a reasonable amount of time.

[1375] Packers, cement, or other sealing systems may be used to inhibit formation fluid from moving up wellbores 490 past an upper portion of nahcolite bed 964 if formation above the nahcolite bed is not to be treated. Packers, cement, or other sealing systems may be used to inhibit formation fluid past a lower portion of nahcolite bed 964' if formation below the nahcolite bed is not to be treated and wellbores 490 extend past the nahcolite bed.

[1376] After solution mining of nahcolite beds 964, 964' is completed, heaters in heater wellbores 490 may raise the temperature of hydrocarbon containing layer 388 to mobilization and/or pyrolysis temperatures. Formation fluid generated from hydrocarbon containing layer 388 may be produced from the formation through converted solution mining wells 944. Initially, vaporized formation fluid may flow along heater wellbores 490 to converted solution mining wells 944 in nahcolite bed 964. Initially, liquid formation fluid may flow along heater wellbores 490 to converted solution mining wells 944 in nahcolite bed 964'. As heating is continued, fractures caused by heating and/or increased permeability due to the removal of material may provide additional fluid pathways to nahcolite beds 964, 964' so that formation fluid generated from hydrocarbon containing layer 388 may be produced from converted solution mining wells 944 in the nahcolite beds. Converted solution mining wells 944 in nahcolite bed 964 may be used to primarily produce vaporized formation fluids. Converted solution mining wells 944 in nahcolite bed 964' may be used to primarily produce liquid formation fluid.

[1377] In some embodiments, the second fluid produced from the formation during solution mining is used to produce sodium bicarbonate. Sodium bicarbonate may be used in the food and pharmaceutical industries, in leather tanning, in fire retardation, in wastewater treatment, and in flue gas treatment (flue gas desulfurization and hydrogen chloride reduction). The second fluid may be kept pressurized and at an elevated temperature when removed from the formation. The second fluid may be cooled in a crystallizer to precipitate sodium bicarbonate.

[1378] In some embodiments, the second fluid produced from the formation during solution mining is used to produce sodium carbonate, which is also referred to as soda ash. Sodium carbonate may be used in the manufacture of glass, in the manufacture of detergents, in water purification, polymer production, tanning, paper manufacturing, effluent neutralization, metal refining, sugar extraction, and/or cement manufacturing. The second fluid removed from the formation may be heated in a treatment facility to form sodium carbonate (soda ash) and/or sodium carbonate brine. Heating sodium bicarbonate will form sodium carbonate according to the equation:

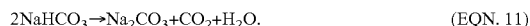

[1379] In certain embodiments, the heat for heating the sodium bicarbonate is provided using heat from the formation. For example, a heat exchanger that uses steam produced from the water introduced into the hot formation may be used to heat the second fluid to dissociation temperatures of the sodium bicarbonate. In some embodiments, the second fluid is circulated through the formation to utilize heat in the formation for further reaction. Steam and/or hot water may also be added to facilitate circulation. The second fluid may be circulated through a heated portion of the formation that has been subjected to the in situ heat treatment process to produce hydrocarbons from the formation. At least a portion of the carbon dioxide generated during sodium carbonate dissociation may be adsorbed on carbon that remains in the formation after the in situ heat treatment process. In some embodiments, the second fluid is circulated through conduits previously used to heat the formation.

[1380] In some embodiments, higher temperatures are used in the formation (for example, above about 120° C., above

about 130° C., above about 150° C., or below about 250° C.) during solution mining of nahcolite. The first fluid is introduced into the formation under pressure sufficient to inhibit sodium bicarbonate from dissociating to produce carbon dioxide. The pressure in the formation may be maintained at sufficiently high pressures to inhibit such nahcolite dissociation but below pressures that would result in fracturing the formation. In addition, the pressure in the formation may be maintained high enough to inhibit steam formation if hot water is being introduced in the formation. In some embodiments, a portion of the nahcolite may begin to decompose in situ. In such cases, nahcolite is removed from the formation as soda ash. If soda ash is produced from solution mining of nahcolite, the soda ash may be transported to a separate facility for treatment. The soda ash may be transported through a pipeline to the separate facility.

[1381] As described above, in certain embodiments, following removal of nahcolite from the formation, the formation is treated using the in situ heat treatment process to produce formation fluids from the formation. In some embodiments, the formation is treating using the in situ heat treatment process before solution mining nahcolite from the formation. The nahcolite may be converted to sodium carbonate (from sodium bicarbonate) during the in situ heat treatment process. The sodium carbonate may be solution mined as described above for solution mining nahcolite prior to the in situ heat treatment process.

[1382] In some formations, dawsonite is present in the formation. Dawsonite within the heated portion of the formation decomposes during heating of the formation to pyrolysis temperature. Dawsonite typically decomposes at temperatures above 270° C. according to the reaction:

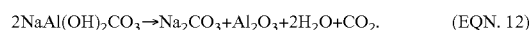

[1383] Sodium carbonate may be removed from the formation by solution mining the formation with water or other fluid into which sodium carbonate is soluble. In certain embodiments, alumina formed by dawsonite decomposition is solution mined using a chelating agent. The chelating agent may be injected through injection wells, production wells, and/or heater wells used for solution mining nahcolite and/or the in situ heat treatment process (for example, injection wells **602**, production wells **206**, and/or heat sources **202** depicted in FIG. **188**). The chelating agent may be an aqueous acid. In certain embodiments, the chelating agent is EDTA (ethylenediaminetetraacetic acid). Other examples of possible chelating agents include, but are not limited to, ethylenediamine, porphyrins, dimercaprol, nitrilotriacetic acid, diethylenetriaminepentaacetic acid, phosphoric acids, acetic acid, acetoxy benzoic acids, nicotinic acid, pyruvic acid, citric acid, tartaric acid, malonic acid, imidazole, ascorbic acid, phenols, hydroxy ketones, sebacic acid, and boric acid. The mixture of chelating agent and alumina may be produced through production wells or other wells used for solution mining and/or the in situ heat treatment process (for example, injection wells **602**, production wells **206**, and/or heat sources **202**, which are depicted in FIG. **188**). The alumina may be separated from the chelating agent in a treatment facility. The recovered chelating agent may be recirculated back to the formation to solution mine more alumina.

[1384] In some embodiments, alumina within the formation may be solution mined using a basic fluid after the in situ heat treatment process. Basic fluids include, but are not limited to, sodium hydroxide, ammonia, magnesium hydroxide,

magnesium carbonate, sodium carbonate, potassium carbonate, pyridine, and amines. In an embodiment, sodium carbonate brine, such as 0.5 Normal Na_2CO_3 , is used to solution mine alumina. Sodium carbonate brine may be obtained from solution mining nahcolite from the formation. Obtaining the basic fluid by solution mining the nahcolite may significantly reduce costs associated with obtaining the basic fluid. The basic fluid may be injected into the formation through a heater well and/or an injection well. The basic fluid may combine with alumina to form an alumina solution that is removed from the formation. The alumina solution may be removed through a heater well, injection well, or production well.

[1385] Alumina may be extracted from the alumina solution in a treatment facility. In an embodiment, carbon dioxide is bubbled through the alumina solution to precipitate the alumina from the basic fluid. Carbon dioxide may be obtained from dissociation of nahcolite, from the in situ heat treatment process, or from decomposition of the dawsonite during the in situ heat treatment process.

[1386] In certain embodiments, a formation may include portions that are significantly rich in either nahcolite or dawsonite only. For example, a formation may contain significant amounts of nahcolite (for example, at least about 20 weight %, at least about 30 weight %, or at least about 40 weight %) in a depocenter of the formation. The depocenter may contain only about 5 weight % or less dawsonite on average. However, in bottom layers of the formation, a weight percent of dawsonite may be about 10 weight % or even as high as about 25 weight %. In such formations, it may be advantageous to solution mine for nahcolite only in nahcolite-rich areas, such as the depocenter, and solution mine for dawsonite only in the dawsonite-rich areas, such as the bottom layers. This selective solution mining may significantly reduce fluid costs, heating costs, and/or equipment costs associated with operating the solution mining process.

[1387] In certain formations, dawsonite composition varies between layers in the formation. For example, some layers of the formation may have dawsonite and some layers may not. In certain embodiments, more heat is provided to layers with more dawsonite than to layers with less dawsonite. Tailoring heat input to provide more heat to certain dawsonite layers more uniformly heats the formation as the reaction to decompose dawsonite absorbs some of the heat intended for pyrolyzing hydrocarbons. FIG. **194** depicts an embodiment for heating a formation with dawsonite in the formation. Hydrocarbon layer **388** may be cored to assess the dawsonite composition of the hydrocarbon layer. The mineral composition may be assessed using, for example, FTIR (Fourier transform infrared spectroscopy) or x-ray diffraction. Assessing the core composition may also assess the nahcolite composition of the core. After assessing the dawsonite composition, heater **412** may be placed in wellbore **490**. Heater **412** includes sections to provide more heat to hydrocarbon layers with more dawsonite in the layers (hydrocarbon layers **388D**). Hydrocarbon layers with less dawsonite (hydrocarbon layers **388C**) are provided with less heat by heater **412**. Heat output of heater **412** may be tailored by, for example, adjusting the resistance of the heater along the length of the heater. In one embodiment, heater **412** is a temperature limited heater, described herein, that has a higher temperature limit (for example, higher Curie temperature) in sections proximate layers **388D** as compared to the temperature limit (Curie temperature) of sections proximate layers **388C**. The resistance of heater **412** may also be adjusted by altering the

resistive conducting materials along the length of the heater to supply a higher energy input (watts per meter) adjacent to dawsonite rich layers.

[1388] Solution mining dawsonite and nahcolite may be relatively simple processes that produce alumina and soda ash from the formation. In some embodiments, hydrocarbons produced from the formation using the in situ heat treatment process may be fuel for a power plant that produces direct current (DC) electricity at or near the site of the in situ heat treatment process. The produced DC electricity may be used on the site to produce aluminum metal from the alumina using the Hall process. Aluminum metal may be produced from the alumina by melting the alumina in a treatment facility on the site. Generating the DC electricity at the site may save on costs associated with using hydrotreaters, pipelines, or other treatment facilities associated with transporting and/or treating hydrocarbons produced from the formation using the in situ heat treatment process.

[1389] In some embodiments, acid may be introduced into the formation through selected wells to increase the porosity adjacent to the wells. For example, acid may be injected if the formation includes limestone or dolomite. The acid used to treat the selected wells may be acid produced during in situ heat treatment of a section of the formation (for example, hydrochloric acid), or acid produced from byproducts of the in situ heat treatment process (for example, sulfuric acid produced from hydrogen sulfide or sulfur).

[1390] In some embodiments, a saline rich zone is located at or near an unleached portion of the formation. The saline rich zone may be an aquifer in which water has leached out nahcolite and/or other minerals. A high flow rate may pass through the saline rich zone. Saline water from the saline rich zone may be used to solution mine another portion of the formation. In certain embodiments, a steam and electricity cogeneration facility may be used to heat the saline water prior to use for solution mining.

[1391] FIG. 195 depicts a representation of an embodiment for solution mining with a steam and electricity cogeneration facility. Treatment area 730 may be formed in unleached portion 954 of the formation (for example, an oil shale formation). Several treatment areas 730 may be formed in unleached portion 954 leaving top, side, and/or bottom walls of unleached formation as barriers around the individual treatment areas to inhibit inflow and outflow of formation fluid during the in situ heat treatment process. The thickness of the walls surrounding the treatment areas may be 10 m or more. For example, the side wall near closest to saline zone 966 may be 60 m or more thick, and the top wall may be 30 m or more thick.

[1392] Treatment area 730 may have significant amounts of nahcolite. Saline zone 966 is located at or near treatment area 730. In certain embodiments, zone 966 is located up dip from treatment area 730. Zone 966 may be leached or partially leached such that the zone is mainly filled with saline water.

[1393] In certain embodiments, saline water is removed (pumped) from zone 966 using production well 206. Production well 206 may be located at or near the lowest portion of zone 966 so that saline water flows into the production well. Saline water removed from zone 966 is heated to hot water and/or steam temperatures in facility 968. Facility 968 may burn hydrocarbons to run generators that produce electricity. Facility 968 may burn gaseous and/or liquid hydrocarbons to make electricity. In some embodiments, pulverized coal is used to make electricity. The electricity generated may be

used to provide electrical power for heaters or other electrical operations (for example, pumping). Waste heat from the generators is used to make hot water and/or steam from the saline water. After the in situ heat treatment process of one or more treatment areas 730 results in the production of hydrocarbons, at least a portion of the produced hydrocarbons may be used as fuel for facility 968.

[1394] The hot water and/or steam made by facility 968 is provided to solution mining well 944. Solution mining well 944 is used to solution mine treatment area 730. Nahcolite and/or other minerals are removed from treatment area 730 by solution mining well 944. The nahcolite may be removed as a nahcolite solution from treatment area 730. The solution removed from treatment area 730 may be a brine solution with dissolved nahcolite. Heat from the removed nahcolite solution may be used in facility 968 to heat saline water from zone 966 and/or other fluids. The nahcolite solution may then be injected through injection well 602 into zone 966. In some embodiments, injection well 602 injects the nahcolite solution into zone 966 up dip from production well 206. Injection may occur a significant distance up dip so that nahcolite solution may be continuously injected as saline water is removed from the zone without the two fluids substantially intermixing. In some embodiments, the nahcolite solution from treatment area 730 is provided to injection well 602 without passing through facility 968 (the nahcolite solution bypasses the facility).

[1395] The nahcolite solution injected into zone 966 may be left in the zone permanently or for an extended period of time (for example, after solution mining, production well 206 may be shut in). In some embodiments, the nahcolite stored in zone 966 is accessed at later times. The nahcolite may be produced by removing saline water from zone 966 and processing the saline water to make sodium bicarbonate and/or soda ash.

[1396] Solution mining using saline water from zone 966 and heat from facility 968 to heat the saline water may be a high efficiency process for solution mining treatment area 730. Facility 968 is efficient at providing heat to the saline water. Using the saline water to solution mine decreases costs associated with pumping and/or transporting water to the treatment site. Additionally, solution mining treatment area 730 preheats the treatment area for any subsequent heat treatment of the treatment area, enriches the hydrocarbon content in the treatment area by removing nahcolite, and/or creates more permeability in the treatment area by removing nahcolite.

[1397] In certain embodiments, treatment area 730 is further treated using an in situ heat treatment process following solution mining of the treatment area. A portion of the electricity generated in facility 968 may be used to power heaters for the in situ heat treatment process.

[1398] In some embodiments, a perimeter barrier may be formed around the portion of the formation to be treated. The perimeter barrier may inhibit migration of formation fluid into or out of the treatment area. The perimeter barrier may be a frozen barrier and/or a grout barrier. After formation of the perimeter barrier, the treatment area may be processed to produce desired products.

[1399] Formations that include non-hydrocarbon materials may be treated to remove and/or dissolve a portion of the non-hydrocarbon materials from a section of the formation before hydrocarbons are produced from the section. In some embodiments, the non-hydrocarbon materials are removed by

solution mining. Removing a portion of the non-hydrocarbon materials may reduce the carbon dioxide generation sources present in the formation. Removing a portion of the non-hydrocarbon materials may increase the porosity and/or permeability of the section of the formation. Removing a portion of the non-hydrocarbon materials may result in a raised temperature in the section of the formation.

[1400] After solution mining, some of the wells in the treatment may be converted to heater wells, injection wells, and/or production wells. In some embodiments, additional wells are formed in the treatment area. The wells may be heater wells, injection wells, and/or production wells. Logging techniques may be employed to assess the physical characteristics, including any vertical shifting resulting from the solution mining, and/or the composition of material in the formation. Packing, baffles or other techniques may be used to inhibit formation fluid from entering the heater wells. The heater wells may be activated to heat the formation to a temperature sufficient to support combustion.

[1401] One or more production wells may be positioned in permeable sections of the treatment area. Production wells may be horizontally and/or vertically oriented. For example, production wells may be positioned in areas of the formation that have a permeability of greater than 5 darcy or 10 darcy. In some embodiments, production wells may be positioned near a perimeter barrier. A production well may allow water and production fluids to be removed from the formation. Positioning the production well near a perimeter barrier enhances the flow of fluids from the warmer zones of the formation to the cooler zones.

[1402] FIG. 196 depicts an embodiment of a process for treating a hydrocarbon containing formation with a combustion front. Barrier 958 (for example, a frozen barrier or a grout barrier) may be formed around a perimeter of treatment area 730 of the formation. The footprint defined by the barrier may have any desired shape such as circular, square, rectangular, polygonal, or irregular shape. Barrier 958 may be formed using one or more barrier wells 200. The barrier may be any barrier formed to inhibit the flow of fluid into or out of treatment area 730. In some embodiments, barrier 958 may be a double barrier.

[1403] Heat may be provided to treatment area 730 through heaters positioned in injection wells 602. In some embodiments, the heaters in injection wells 602 heat formation adjacent to the injection wells to temperatures sufficient to support combustion. Heaters in injection wells 602 may raise the formation near the injection wells to temperatures from about 90° C. to about 120° C. or higher (for example, a temperature of about 90° C., 95° C., 100° C., 110° C., or 120° C.).

[1404] Injection wells 602 may be used to introduce a combustion fuel, an oxidant, steam and/or a heat transfer fluid into treatment area 730, either before, during, or after heat is provided to treatment area 730 from heaters. In some embodiments, injection wells 602 are in communication with each other to allow the introduced fluid to flow from one well to another. Injection wells 602 may be located at positions that are relatively far away from perimeter barrier 958. Introduced fluid may cause combustion of hydrocarbons in treatment area 730. Heat from the combustion may heat treatment area 730 and mobilize fluids toward production wells 206.

[1405] A temperature of treatment area 730 may be monitored using temperature measurement devices placed in

monitoring wells and/or temperature measurement devices in injection wells 602, production wells 206, and/or heater wells.

[1406] In some embodiments, a controlled amount of oxidant (for example, air and/or oxygen) is provided in injection wells 602 to advance a heat front towards production wells 206. In some embodiments, the controlled amount of oxidant is introduced into the formation after solution mining has established permeable interconnectivity between at least two injection wells. The amount of oxidant is controlled to limit the advancement rate of the heat front and to limit the temperature of the heat front. The advancing heat front may pyrolyze hydrocarbons. The high permeability in the formation allows the pyrolyzed hydrocarbons to spread in the formation towards production wells without being overtaken by the advancing heat front.

[1407] Vaporized formation fluid and/or gas formed during the combustion process may be removed through gas wells 970 and/or injection wells 602. Venting of gases through gas wells 970 and/or injection wells 602 may force the combustion front in a desired direction.

[1408] In some embodiments, the formation may be heated to a temperature sufficient to cause pyrolysis of the formation fluid by the steam and/or heat transfer fluid. The steam and/or heat transfer fluid may be heated to temperatures of about 300° C., about 400° C., about 500° C., or about 600° C. In certain embodiments, the steam and/or heat transfer fluid may be co-injected with the fuel and/or oxidant.

[1409] FIG. 197 depicts a cross-sectional representation of an embodiment for treating a hydrocarbon containing formation with a combustion front. As the combustion front is initiated and/or fueled through injection wells 602, formation fluid near periphery 972 of the combustion front becomes mobile and flow towards production wells 206 located proximate barrier 958. Injection wells may include smart well technology. Combustion products and noncondensable formation fluid may be removed from the formation through gas wells 970. In some embodiments, no gas wells are formed in the formation. In such embodiments, formation fluid, combustion products and noncondensable formation fluid are produced through production wells 206. In embodiments that include gas wells 970, condensable formation fluid may be produced through production well 206. In some embodiments, production well 206 is located below injection well 602. Production well 206 may be about 1 m, 5 m, 10 m or more below injection well 602. Production well may be a horizontal well. Periphery 972 of the combustion front may advance from the toe of production well 206 towards the heel of the production well. Production well 206 may include a perforated liner that allows hydrocarbons to flow into the production well. In some embodiments, a catalyst may be placed in production well 206. The catalyst may upgrade and/or stabilize formation fluid in the production well.

[1410] Gases may be produced during in situ heat treatment processes and during many conventional production processes. Some of the produced gases (for example, carbon dioxide and/or hydrogen sulfide) when introduced into water may change the pH of the water to less than 7. Such gases are typically referred to as sour gas or acidic gas. Introducing sour gas from produced fluid into subsurface formations may reduce or eliminate the need for or size of certain surface facilities (for example, a Claus plant or Scot gas treater). Introducing sour gas from produced formation fluid into subsurface formations may make the formation fluid more

acceptable for transportation, use, and/or processing. Removal of sour gas having a low heating value (for example, carbon dioxide) from formation fluids may increase the caloric value of the gas stream separated from the formation fluid.

[1411] Net release of sour gas to the atmosphere and/or conversion of sour gas to other compounds may be reduced by utilizing the produced sour gas and/or by storing the sour gas within subsurface formations. In some embodiments, the sour gas is stored in deep saline aquifers. Deep saline aquifers may be at depths of about 900 m or more below the surface. The deep saline aquifers may be relatively thick and permeable. A thick and relatively impermeable formation strata may be located over deep saline aquifers. For example, 500 m or more of shale may be located above the deep saline aquifer. The water in the deep saline aquifer may be unusable for agricultural or other common uses because of the high mineral content in the water. Over time, the minerals in the water may react with introduced sour gas to form precipitates in the deep saline aquifer. The deep saline aquifer used to store sour gas may be below the treatment area, at another location in the same formation, or in another formation. If the deep saline aquifer is located at another location in the same formation or in another formation, the sour gas may be transported to the deep saline aquifer by pipeline.

[1412] In certain embodiments, a temperature measurement tool assesses the active impedance of an energized heater. The temperature measurement tool may utilize the frequency domain analysis algorithm associated with Partial Discharge measurement technology (PD) coupled with timed domain reflectometer measurement technology (TDR). A set of frequency domain analysis tools may be applied to a TDR signature. This process may provide unique information in the analysis of the energized heater such as, but not limited to, an impedance log of the entire length of the heater per unit length. The temperature measurement tool may provide certain advantages for assessing the temperature of a downhole heater.

[1413] In certain embodiments, the temperature measurement tool assesses the impedance per unit length and gives a profile on the entire length of the heated section of the heater. The impedance profile may be used in association with laboratory data for the heater (such as temperature and resistance profiles for heaters measured at various loads and frequencies) to assess the temperature per unit length of the heated section. The impedance profile may also be used to assess various computer models for heaters that are used in association with the reservoir simulations.

[1414] In certain embodiments, the temperature measurement tool assesses an accurate impedance profile of a heater in a specific formation after a number of heater wells have been installed and energized in the specific formation. The accurate impedance profile may assess the actual reactive and real power consumption for each heater that is used similarly. This information may be used to properly size surface electrical distribution equipment and/or eliminate any extra capacity designed to accommodate any anticipated heater impedance turndown ratio or any unknown power factor or reactive power consumption for the heaters.

[1415] In certain embodiments, the temperature measurement tool is used to troubleshoot malfunctioning heaters and assess the impedance profile of the length of the heated section. The impedance profile may be able to accurately predict the location of a faulted section and its relative impedance to

ground. This information may be used to accurately assess the appropriate reduction in surface voltage to allow the heater to continue to operate in a limited capacity. This method may be more preferable than abandoning the heater in the formation.

[1416] In certain embodiments, frequency domain PD testing offers an improved set of PD characterization tools. A basic set of frequency domain PD testing tools are described in "The Case for Frequency Domain PD Testing In The Context Of Distribution Cable", Steven Boggs, *Electrical Insulation Magazine, IEEE*, Vol. 19, Issue 4, July-August 2003, pages 13-19, which is incorporated by reference as if fully set forth herein. Frequency domain PD detection sensitivity under field conditions may be one to two orders of magnitude greater than for time domain testing as a result of there not being a need to trigger on the first PD pulse above the broadband noise, and the filtering effect of the cable between the PD detection site and the terminations. As a result of this greatly increased sensitivity and the set of characterization tools, frequency domain PD testing has been developed into a highly sensitive and reliable tool for characterizing the condition of distribution cable during normal operation while the cable is energized.

[1417] During or after solution mining and/or the in situ heat treatment process, some existing cased heater wells and/or some existing cased monitor wells may be converted into production wells and/or injection wells. Existing cased wells may be converted to production and/or injection wells by perforating a portion of the well casing with perforation devices that utilize explosives. Also, some production wells may be perforated at one or more cased locations to facilitate removal of formation fluid through newly opened sections in the production wells. In some embodiments, perforation devices may be used in open wellbores to fracture formation adjacent to the wellbore.

[1418] In some embodiments, pre-perforated portions of wells are installed. Coverings may initially be placed over the perforations. At a desired time, the covering of the perforations may be removed to open additional portions of the wells or to convert the wells to production wells and/or injection wells. Knowing which wells will need to be converted to production wells and/or injection wells may not be apparent at the time of well installation. Using pre-perforated wells for all wells may be prohibitively expensive.

[1419] Perforation devices may be used to form openings in a well. Perforation devices may be obtained from, for example, Schlumberger USA (Sugar Land, Tex., USA). Perforation devices may include, but are not limited to, capsule guns and/or hollow carrier guns. Perforation devices may use explosives to form openings in a well. The well may need to be at a relatively cool temperature to inhibit premature detonation of the explosives. Temperature exposure limits of some explosives commonly used for perforation devices are a maximum exposure of 1 hour to a temperature of about 260° C., and a maximum exposure of 10 hours to a temperature of about 210° C. In some embodiments, the well is cooled before use of the perforation device. In some embodiments, the perforation device is insulated to inhibit heat transfer to the perforation device. The use of insulation may not be suitable for wells with portions that are at high temperature (for example, above 300° C.).

[1420] In some embodiments, the perforation device is equipped with a circulated fluid cooling system. The circulated fluid cooling system may keep the temperature of the perforation device below a desired value. Keeping the tem-

perature of the perforation device below a selected temperature may inhibit premature detonation of explosives in the perforation device.

[1421] One or more temperature sensing devices may be included in the circulated fluid cooling system to allow temperatures in the well and/or near the perforating device to be observed. After insertion into the well, the perforation device may be activated to form openings in the well. The openings may be of sufficient size to allow fluid to be pumped through the well after removal of the perforation device positioning apparatus.

[1422] FIG. 198 represents a perspective view of circulated fluid cooling system 974 that provides continuous and/or semi-continuous cooling fluid to perforating device 976. Circulated fluid cooling system 974 may include outer tubing 480, inner tubing 978, connectors 980, sleeve 982, support 984, perforating device 976, temperature sensor 986, and control cable 988.

[1423] Sleeve 982 may be coupled to outer tubing 480 by connector 980. In some embodiments, outer tubing 480 is a coiled tubing string, and connector 980 is a threaded connection. Sleeve 982 may be a thin walled sleeve. In some embodiments, sleeve 982 is made of a polymer. Sleeve 982 may have minimal thickness to maximize explosive performance of perforation device 976, yet still be sufficiently strong to support the forces applied to the sleeve by the hydrostatic column and circulation of cooling fluid.

[1424] Inner tubing 978 may be positioned inside of outer tubing 480. In some embodiments, inner tubing 978 is a coiled tubing string. Support 984 may be coupled to inner tubing by connector 980. In some embodiments, support 984 is a pipe and connector 980 is a threaded connection. Perforation device 976 may be secured to the outside of support 984. A number of perforation devices may be secured to the outside of the support in series. Using a number of perforation devices may allow a long length of perforations to be formed in the well on a single trip of circulated fluid cooling system 974 into the well.

[1425] Temperature sensor 986 and control cable 988 may be positioned through inner tubing 978 and support 984. Temperature sensor 986 may be a fiber optic cable or plurality of thermocouples that are capable of sensing temperature at various locations in circulated fluid cooling system 974. Control cable 988 may be coupled to perforation device 976. A signal may be sent through control cable to detonate explosives in perforation device 976.

[1426] Cooling fluid 990 may flow downwards through inner tubing 978 and support 984 and return to the surface past perforation device 976 in the space between the support and sleeve 982 and in the space between the inner tubing and outer tubing 480. Cooling fluid 990 may be water, glycol, or any other suitable heat transfer fluid.

[1427] In some embodiments, a long length of support 984 and sleeve 982 may be left below perforation device 976 as a dummy section. Temperature measurements taken by temperature sensor 986 in the dummy section may be used to monitor the temperature rise of the leading portion of circulated fluid cooling system 974 as the circulated fluid cooling system is introduced into the well. The dummy section may also be a temperature buffer for perforation device 976 that inhibits rapid temperature rise in the perforation device. In other embodiments, the circulated fluid cooling system may be introduced into the well without perforation devices to determine that the temperature increase the perforation

device will be exposed to will be known before the perforation device is placed in the well.

[1428] To use circulated fluid cooling system 974, the circulated fluid cooling system is lowered into the well. Cooling fluid 990 keeps the temperature of perforation device 976 below temperatures that may result in the premature detonation of explosives of the perforation device. After the perforation device is positioned at the desired location in the well, circulation of cooling fluid 990 is stopped. In some embodiments, cooling fluid 990 is removed from circulated fluid cooling system 974. Then, control cable 988 may be used to detonate the explosives of perforation device 976 to form openings in the well. Outer tubing 480 and inner tubing 978 may be removed from the well, and the remaining portions of sleeve 982 and/or support 984 may be disconnected from the outer tubing and the inner tubing.

[1429] To perforate another well, a new perforation device may be secured to the support if the support is reusable. The support may be coupled to inner tubing, and a new sleeve may be coupled to the outer tubing. The newly reformed circulated fluid cooling system 974 may be deployed in the well to be perforated.

[1430] Subsurface formations (for example, tar sands or heavy hydrocarbon formations) include dielectric media. Dielectric media may exhibit conductivity, relative dielectric constant, and loss tangents at temperatures below 100° C. Loss of conductivity, relative dielectric constant, and dissipation factor may occur as the formation is heated to temperatures above 100° C. due to the loss of moisture contained in the interstitial spaces in the rock matrix of the formation. To prevent loss of moisture, formations may be heated at temperatures and pressures that minimize vaporization of water. Conductive solutions may be added to the formation to help maintain the electrical properties of the formation.

[1431] Formations may be heated using electrodes to temperatures and pressures that vaporize the water and/or conductive solutions. Material used to produce the current flow, however, may become damaged due to heat stress and/or loss of conductive solutions may limit heat transfer in the layer. In addition, when using electrodes, magnetic fields may form. Due to the presence of magnetic fields, non-ferromagnetic materials may be desired for overburden casings.

[1432] Heat sources with electrically conducting material may allow current flow through a formation from one heat source to another heat source. Current flow between the heat sources with electrically conducting material may heat the formation to increase permeability in the formation and/or lower viscosity of hydrocarbons in the formation. Heating using current flow or "joule heating" through the formation may heat portions of the hydrocarbon layer in a shorter amount of time relative to heating the hydrocarbon layer using conductive heating between heaters spaced apart in the formation.

[1433] In some embodiments, heat sources that include electrically conductive materials are positioned in a hydrocarbon layer. Portions of the hydrocarbon layer may be heated from current generated from the heat sources that flows from the heat sources and through the layer. Positioning of electrically conductive heat sources in a hydrocarbon layer at depths sufficient to minimize loss of conductive solutions may allow hydrocarbons layers to be heated at relatively high temperatures over a period of time with minimal loss of water and/or conductive solutions.

[1434] FIGS. 199-203 depict schematics of embodiments for treating a subsurface formation using heat sources having electrically conductive material. FIG. 199 depicts first conduit 992 and second conduit 994 positioned in wellbores 490, 490' in hydrocarbon layer 388. In certain embodiments, first conduit 992 and/or second conduit 994 are conductors (for example, exposed metal or bare metal conductors). In some embodiments, conduits 992, 994 are oriented substantially horizontally or at an incline in the formation. Conduits 992, 994 may be positioned in or near a bottom portion of hydrocarbon layer 388.

[1435] Wellbores 490, 490' may be open wellbores. In some embodiments, the conduits extend from a portion of the wellbore. In some embodiments, the vertical or overburden portions of wellbores 490, 490' are cemented with non-conductive cement or foam cement. Wellbores 490, 490' may include packers 948 and/or electrical insulators 996. In some embodiments, packers 948 are not necessary. Electrical insulators 996 may insulate conduits 992, 994 from casing 398.

[1436] In some embodiments, the portion of casing 398 adjacent to overburden 400 is made of material that inhibits ferromagnetic effects. The casing in the overburden may be made of fiberglass, polymers, and/or a non-ferromagnetic metal (for example, a high manganese steel). Inhibiting ferromagnetic effects in the portion of casing 398 adjacent to overburden 400 may reduce heat losses to the overburden and/or electrical losses in the overburden. In some embodiments, overburden casings 398 include non-metallic materials such as fiberglass, polyvinylchloride (PVC), chlorinated polyvinylchloride (CPVC), high-density polyethylene (HDPE), and/or non-ferromagnetic metals (for example, non-ferromagnetic high manganese steels). HDPEs with working temperatures in a range for use in overburden 400 include HDPEs available from Dow Chemical Co., Inc (Midland, Mich., U.S.A.). In some embodiments, casing 398 includes carbon steel coupled on the inside and/or outside diameter of a non-ferromagnetic metal (for example, carbon steel clad with copper or aluminum) to inhibit ferromagnetic effects or inductive effects in the carbon steel. Other non-ferromagnetic metals include, but are not limited to, manganese steels with at least 15% by weight manganese, 0.7% by weight carbon, 2% by weight chromium, iron aluminum alloys with at least 18% by weight aluminum, and austenitic stainless steels such as 304 stainless steel or 316 stainless steel.

[1437] Portions or all of conduits 992, 994 may include electrically conductive material 998. Electrically conductive materials include, but are not limited to, thick walled copper, heat treated copper ("hardened copper"), carbon steel clad with copper, aluminum, or aluminum or copper clad with stainless steel. Conduits 992, 994 may have dimensions and characteristics that enable the conduits to be used later as injection wells and/or production wells. Conduit 992 and/or conduit 994 may include perforations or openings 1000 to allow fluid to flow into or out of the conduits. In some embodiments, portions of conduit 992 and/or conduit 994 are pre-perforated with coverings initially placed over the perforations and removed later. In some embodiments, conduit 992 and/or conduit 994 include slotted liners.

[1438] After a desired time (for example, after injectivity has been established in the layer), the coverings of the perforations may be removed or slots may be opened to open portions of conduit 992 and/or conduit 994 to convert the conduits to production wells and/or injection wells. In some embodiments, coverings are removed by inserting an expand-

able mandrel in the conduits to remove coverings and/or open slots. In some embodiments, heat is used to degrade material placed in the openings in conduit 992 and/or conduit 994. After degradation, fluid may flow into or out of conduit 992 and/or conduit 994.

[1439] Power to electrically conductive material 998 may be supplied from one or more surface power supplies through conductors 1002, 1002'. Conductors 1002, 1002' may be cables supported on a tubular or other support member. In some embodiments, conductors 1002, 1002' are conduits through which electricity flows to conduit 992 or conduit 994. Electrical connectors 1004 may be used to electrically couple conductors 1002, 1002' to conduits 992, 994. Conductor 1002 and conductor 1002' may be coupled to the same power supply to form an electrical circuit. Sections of casing 398 (for example a section between packers 948 and electrical connectors 1004) may include or be made of insulating material (such as enamel coating) to prevent leakage of electrical current towards the surface of the formation.

[1440] In some embodiments, a direct current power source is supplied to either first conduit 992 or second conduit 994. In some embodiments, time varying current is supplied to first conduit 992 and/or second conduit 994. Current flowing from conductors 1002, 1002' to conduits 992, 994 may be low frequency current (for example, about 50 Hz, about 60 Hz, or frequencies up to about 1000 Hz). A voltage differential between the first conduit 992 and second conduit 994 may range from about 100 volts to about 1200 volts, from about 200 volts to about 1000 volts, or from about 500 volts to 700 volts. In some embodiments, higher frequency current and/or higher voltage differentials may be utilized. Use of time varying current may allow longer conduits to be positioned in the formation. Use of longer conduits allows more of the formation to be heated at one time and may decrease overall operating expenses. Current flowing to first conduit 992 may flow through hydrocarbon layer 388 to second conduit 994, and back to the power supply. Flow of current through hydrocarbon layer 388 may cause resistance heating of the hydrocarbon layer.

[1441] During the heating process, current flow in conduits 992, 994 may be measured at the surface. Measuring of the current entering conduits 992, 994 may be used to monitor the progress of the heating process. Current between conduits 992, 994 may increase steadily until a predetermined upper limit (I_{max}) is reached. In some embodiments, vaporization of water occurs at the conduits, at which time a drop in current is observed. Current flow of the system is indicated by arrows 1006. Current flow in hydrocarbon containing layer 388 between conduits 992, 994 heats the hydrocarbon layer between and around the conduits. Conduits 992, 994 may be part of a pattern of conduits in the formation that provide multiple pathways between wells so that a large portion of layer 388 is heated. The pattern may be a regular pattern, (for example, a triangular or rectangular pattern) or an irregular pattern.

[1442] FIG. 200 depicts a schematic of an embodiment of a system for treating a subsurface formation using electrically conductive material. Conduit 1008 and ground 1010 may extend from wellbores 490, 490' into hydrocarbon layer 388. Ground 1010 may be a rod or a conduit positioned in hydrocarbon layer 388 between about 5 m and about 30 m away from conduit 1008 (for example, about 10 m, about 15 m, or about 20 m). In some embodiments, electrical insulators 996' electrically isolate ground 1010 from casing 398' and/or con-

duit section-1012 positioned in wellbore 490'. As shown, ground 1010 is a conduit that includes openings 1000.

[1443] Conduit 1008 may include sections 1014, 1016 of conductive material 998. Sections 1014, 1016 may be separated by electrically insulating material 1018. Electrically insulating material 1018 may include polymers and/or one or more ceramic isolators. Section 1014 may be electrically coupled to the power supply by conductor 1002. Section 1016 may be electrically coupled to the power supply by conductor 1002'. Electrical insulators 996 may separate conductor 1002 from conductor 1002'. Electrically insulating material 1018 may have dimensions and insulating properties sufficient to inhibit current from section 1014 flowing across insulation material 1018 to section 1016. For example, a length of electrically insulating material 1018 may be about 30 meters, about 35 meters, about 40 meters, or greater. Using a conduit that has electrically conductive sections 1014, 1016 may allow fewer wellbores to be drilled in the formation. Conduits having electrically conductive sections ("segmented heat sources") may allow longer conduit lengths. In some embodiments, segmented heat sources allow injection wells used for drive processes (for example, steam assisted gravity drainage and/or cyclic steam drive processes) to be spaced further apart, and thus achieve an overall higher recovery efficiency.

[1444] Current provided through conductor 1002 may flow to conductive section 1014 through hydrocarbon layer 388 to a section of ground 1010 opposite section 1014. The electrical current may flow along ground 1010 to a section of the ground opposite section 1016. The current may flow through hydrocarbon layer 388 to section 1016 and through conductor 1002' back to the power circuit to complete the electrical circuit. Electrical connector 1020 may electrically couple section 1016 to conductor 1002'. Current flow is indicated by arrows 1006. Current flow through hydrocarbon layer 388 may heat the hydrocarbon layer to create fluid injectivity in the layer, mobilize hydrocarbons in the layer, and/or pyrolyze hydrocarbons in the layer. When using segmented heat sources, the amount of current required for the initial heating of the hydrocarbon layer may be at least 50% less than current required for heating using two non-segmented heat sources or two electrodes. Hydrocarbons may be produced from hydrocarbon layer 388 and/or other sections of the formation using production wells. In some embodiments, one or more portions of conduit 1008 is positioned in a shale layer and ground 1010 is positioned in hydrocarbon layer 388. Current flow through conductors 1002, 1002' in opposite directions may allow for cancellation of at least a portion of the magnetic fields due to the current flow. Cancellation of at least a portion of the magnetic fields may inhibit induction effects in the overburden portion of conduit 1008 and the wellhead of wellbore 490.

[1445] FIG. 201 depicts an embodiment in which first conduit 1008 and second conduit 1008' are used for heating hydrocarbon layer 388. Electrically insulating material 1018 may separate sections 1014, 1016 of first conduit 1008. Electrically insulating material 1018' may separate sections 1014', 1016' of second conduit 1008'.

[1446] Current may flow from a power source through conductor 1002 of first conduit 1008 to section 1014. The current may flow through hydrocarbon containing layer 388 to section 1016' of second conduit 1008'. The current may return to the power source through conductor 1002' of second conduit 1008'. Similarly, current may flow through conductor 1002 of second conduit 1008' to section 1014', through hydrocarbon

layer 388 to section 1016 of first conduit 1008, and the current may return to the power source through conductor 1002' of the first conduit 1008. Current flow is indicated by arrows 1006. Generation of current flow from electrically conductive sections of conduits 1008, 1008' may heat portions of hydrocarbon layer 388 between the conduits and create fluid injectivity in the layer, mobilize hydrocarbons in the layer, and/or pyrolyze hydrocarbons in the layer. In some embodiments, one or more portions of conduits 1008, 1008' are positioned in shale layers.

[1447] By creating opposite current flow through the wellbores, as described with reference to FIGS. 200 and 201, magnetic fields in the overburden may cancel out. Cancellation of the magnetic fields in the overburden may allow ferromagnetic materials to be used in overburden casings 398. Using ferromagnetic casings in the wellbores may be less expensive and/or easier to install than non-ferromagnetic casings (such as fiberglass casings).

[1448] In some embodiments, two or more conduits may branch from a common wellbore. FIG. 202 depicts a schematic of an embodiment of two conduits extending from one common wellbore. Extending the conduits from one common wellbore may reduce costs by forming fewer wellbores in the formation. Using common wellbores may allow wellbores to be spaced further apart and produce the same heating efficiencies and the same heating times as drilling two different wellbores for each conduit through the formation. Using common wellbores may allow ferromagnetic materials to be used in overburden casing 398 since the magnetic fields cancel due to the approximately equal and opposite flow of current in the overburden section of conduits 992, 994. Extending conduits from one common wellbore may allow longer conduits to be used.

[1449] Conduits 992, 994 may extend from common vertical portion 1022 of wellbore 490. Conduit 994 may be installed through an opening (for example, a milled window) in vertical portion 1022. Conduits 992, 994 may extend substantially horizontally or inclined from vertical portion 1022. Conduits 992, 994 may include electrically conductive material 998. In some embodiments, conduits 992, 994 include electrically conductive sections and electrically insulating material, as described for conduit 1008 in FIGS. 200 and 201. Conduit 992 and/or conduit 994 may include openings 1000. Current may flow from a power source to conduit 992 through conductor 1002. The current may pass through hydrocarbon containing layer 388 to conduit 994. The current may pass from conduit 994 through conductor 1002' back to the power source to complete the circuit. The flow of current as shown by arrows 1006 through hydrocarbon layer 388 from conduits 992, 994 heats the hydrocarbon layer between the conduits.

[1450] In some embodiments, a subsurface formation is heated using heating systems described in the embodiments depicted in FIGS. 199, 200, 201, and/or 202 to heat fluids in hydrocarbon layer 388 to mobilization, visbreaking, and/or pyrolyzation temperatures. Such heated fluids may be produced from the hydrocarbon layer and/or from other sections of the formation. As the hydrocarbon layer 388 is heated, the conductivity of the heated portion of the hydrocarbon layer increases. For example, conductivity of hydrocarbon layers close to the surface may increase by as much as a factor of three when the temperature of the formation increases from 20° C. to 100° C. For deeper layers, where the water vaporization temperature is higher due to increased fluid pressure, the increase in conductivity may be greater. Greater increases

in conductivity may increase the heating rate of the formation. Thus, as the conductivity increases in the formation, increases in heating may be more concentrated in deeper layers.

[1451] As a result of heating, the viscosity of heavy hydrocarbons in a hydrocarbon layer is reduced. Reducing the viscosity may create more injectivity in the layer and/or mobilize hydrocarbons in the layer. As a result of being able to rapidly heat the hydrocarbon layer using heating systems described in the embodiments depicted in FIGS. 199, 200, 201, and/or 202, sufficient fluid injectivity in the hydrocarbon layer may be achieved more quickly, for example, in about two years. In some embodiments, these heating systems are used to create drainage paths between the heat sources and production wells for a drive and/or a mobilization process. In some embodiments, these heating systems are used to provide heat during the drive process. The amount of heat provided by the heating systems may be small compared to the heat input from the drive process (for example, the heat input from steam injection).

[1452] Once sufficient fluid injectivity has been established, a drive fluid, a pressurizing fluid, and/or a solvation fluid may be injected in the heated portion of hydrocarbon layer 388. In some embodiments (for example, the embodiments depicted in FIGS. 199 and 202), conduit 994 is perforated and fluid is injected through the conduit to mobilize and/or further heat hydrocarbon layer 388. Fluids may drain and/or be mobilized towards conduit 992. Conduit 992 may be perforated at the same time as conduit 994 or perforated at the start of production. Formation fluids may be produced through conduit 992 and/or other sections of the formation.

[1453] As shown in FIG. 203, conduit 992 is positioned in layer 1024 located between hydrocarbon layers 388A and 388B. Conduit 994 is positioned in hydrocarbon layer 388A. Conduits 992, 994, shown in FIG. 203, may be any of conduits 992, 994, depicted in FIG. 199 and/or 202, as well as conduits 1008, 1008' or ground 1010, depicted in FIGS. 200 and 201. In some embodiments, portions of conduit 992 are positioned in hydrocarbon layers 388A or 388B and in layer 1024.

[1454] Layer 1024 may be a conductive layer, water/sand layer, or hydrocarbon layer that has different porosity than hydrocarbon layer 388A and/or hydrocarbon layer 388B. In some embodiments, layer 1024 is a shale layer. Layer 1024 may have conductivities ranging from about 0.2 mho/m to about 0.5 mho/m. Hydrocarbon layers 388A and/or 388B may have conductivities ranging from about 0.02 mho/m to about 0.05 mho/m. Conductivity ratios between layer 1024 and hydrocarbon layers 388A and/or 388B may range from about 10:1, about 20:1, or about 100:1. When layer 1024 is a shale layer, heating the layer may desiccate the shale layer and increase the permeability of the shale layer to allow fluid to flow through the shale layer. The increased permeability in the shale layer allows mobilized hydrocarbons to flow from hydrocarbon layer 388A to hydrocarbon layer 388B, allows drive fluids to be injected in hydrocarbon layer 388A, and/or allows steam drive processes (for example, SAGD, cyclic steam soak (CSS), sequential CSS and SAGD or steam flood, or simultaneous SAGD and CSS) to be performed in hydrocarbon layer 388A.

[1455] In some embodiments, a conductive layer is selected to provide lateral continuity of conductivity within the conductive layer and to provide a substantially higher conductivity, for a given thickness, than the surrounding hydrocarbon

layers. Thin conductive layers selected on this basis may substantially confine the heat generation within and around the conductive layers and allow much greater spacing between rows of electrodes. In some embodiments, layers to be heated are selected, on the basis of resistivity well logs, to provide lateral continuity of conductivity. Selection of layers to be heated is described in U.S. Pat. No. 4,926,941 to Glandt et al., which is incorporated herein by reference.

[1456] Once sufficient fluid injectivity is created, fluid may be injected in layer 1024 through an injection well and/or conduit 992 to heat or mobilize fluids in hydrocarbon layer 388B. Fluids may be produced from hydrocarbon layer 388B and/or other sections of the formation. In some embodiments, fluid is injected in conduit 994 to mobilize and/or heat in hydrocarbon layer 388A. Heated and/or mobilized fluids may be produced from conduit 992 and/or other production wells located in hydrocarbon layer 388B and/or other sections of the formation.

[1457] In certain embodiments, a solvation fluid, in combination with a pressurizing fluid, is used to treat the hydrocarbon formation in addition to the in situ heat treatment process. In some embodiments, the solvation fluid, in combination with the pressurizing fluid, is used after the hydrocarbon formation has been treated using a drive process. In some embodiments, solvation fluids are foamed or made into foams to improve the efficiency of the drive process. Since an effective viscosity of the foam may be greater than the viscosity of the individual components, the use of a foaming composition may improve the sweep efficiency of the drive fluid.

[1458] In some embodiments, the solvation fluid includes a foaming composition. The foaming composition may be injected simultaneously or alternately with the pressurizing fluid and/or the drive fluid to form foam in the heated section. Use of foaming compositions may be more advantageous than use of polymer solutions since foaming compositions are thermally stable at temperatures up to 600° C. while polymer compositions may degrade at temperatures above 150° C. Use of foaming compositions at temperatures above about 150° C. may allow more hydrocarbon fluids and/or more efficient removal of hydrocarbons from the formation as compared to use of polymer compositions.

[1459] Foaming compositions may include, but are not limited to, surfactants. In certain embodiments, the foaming composition includes a polymer, a surfactant, an inorganic base, water, steam, and/or brine. The inorganic base may include, but is not limited to, sodium hydroxide, potassium hydroxide, potassium carbonate, potassium bicarbonate, sodium carbonate, sodium bicarbonate, or mixtures thereof. Polymers include polymers soluble in water or brine such as, but not limited to, ethylene oxide or propylene oxide polymers.

[1460] Surfactants include ionic surfactants and/or non-ionic surfactants. Examples of ionic surfactants include alpha-olefinic sulfonates, alkyl sodium sulfonates, and sodium alkyl benzene sulfonates. Non-ionic surfactants include, for example, triethanolamine Surfactants capable of forming foams include, but are not limited to, alpha-olefinic sulfonates, alkylpolyalkoxyalkylene sulfonates, aromatic sulfonates, alkyl aromatic sulfonates, alcohol ethoxy glycerol sulfonates (AEGS), or mixtures thereof. Non-limiting examples of surfactants capable of being foamed include AEGS 25-12 surfactant, sodium dodecyl 3EO sulfate, and sulfates made from branched alcohols made using the Guer-

bet method such as, for example, sodium dodecyl (Guerbert) 3PO sulfate⁶³, ammonium isotridecyl(Guerbert) 4PO sulfate⁶³, sodium tetradecyl (Guerbert) 4PO sulfate⁶³. Nonionic and ionic surfactants and/or methods of use and/or methods of foaming for treating a hydrocarbon formation are described in U.S. Pat. No. 4,643,256 to Dilgren et al.; U.S. Pat. No. 5,193,618 to Loh et al.; U.S. Pat. No. 5,046,560 to Teletzke et al.; U.S. Pat. No. 5,358,045 to Seigny et al.; U.S. Pat. No. 6,439,308 to Wang; U.S. Pat. No. 7,055,602 to Shpakoff et al.; U.S. Pat. No. 7,137,447 to Shpakoff et al.; U.S. Pat. No. 7,229,950 to Shpakoff et al.; and U.S. Pat. No. 7,262,153 to Shpakoff et al.; and by Wellington et al, in "Surfactant-Induced Mobility Control for Carbon Dioxide Studied with Computerized Tomography," American Chemical Society Symposium Series No. 373, 1988.

[1461] Foam may be formed in the formation by injecting the foaming composition during or after addition of steam. Pressurizing fluid (for example, carbon dioxide, methane, and/or nitrogen) may be injected in the formation before, during, or after the foaming composition is injected. A type of pressurizing fluid may be based on the surfactant used in the foaming composition. For example, carbon dioxide may be used with alcohol ethoxy glycerol sulfonates. The pressurizing fluid and foaming composition may mix in the formation and produce foam. In some embodiments, non-condensable gas is mixed with the foaming composition prior to injection to form a pre-foamed composition. The foaming composition, the pressurizing fluid, and/or the pre-foamed composition may be periodically injected in the heated formation. The foaming composition, pre-foamed compositions, drive fluids, and/or pressurizing fluids may be injected at a pressure sufficient to displace the formation fluids without fracturing the reservoir.

[1462] In some embodiments, electrodes may be positioned in wellbores to heat hydrocarbon layers in a subsurface formation. Electrodes may be positioned vertically in the hydrocarbon formation or oriented substantially horizontal or inclined. Heating hydrocarbon formations with electrodes is described in U.S. Pat. No. 4,084,637 to Todd; U.S. Pat. No. 4,926,941 to Glandt et al.; and U.S. Pat. No. 5,046,559 to Glandt, all of which are incorporate herein by reference in their entirety. Electrodes used for heating hydrocarbon formations may have bare elements at the ends of the electrodes. Heating of the hydrocarbon layers may subject the bare element ends to increased current because of the near and far field voltage fields concentrating on the ends. Coating of the electrode to form high voltage stress cones ("stress grading") around sections of the electrode or the entire electrode may enhance the performance of the electrode. FIG. 204A depicts a schematic of an embodiment of an electrode with a sleeve over a section of the electrode. FIG. 204B depicts a schematic of an embodiment of an uncoated electrode. FIG. 205A depicts a schematic of another embodiment of a coated electrode. FIG. 205B depicts a schematic of another embodiment of an uncoated electrode. Electrode 1020 may include a coating that forms sleeve 1026 around an end (as shown in FIG. 204A) or substantially all (as shown in FIG. 205A) of the electrode. Sleeve 1026 may be formed from a positive temperature coefficient polymer and/or a heat shrinkable material. When sleeve 1026 is coated, as shown by arrows in FIGS. 204A and 205A, current flow is distributed outwardly along sleeve 1026 when electrode 1020 is energized rather than the ends or portions of the electrode, as shown in FIGS. 204B and 205B.

[1463] In some embodiments, bulk resistance along sections of the electrode may be increased by layering conductive materials and insulating layers along a section of the electrode. Examples of such electrodes are electrodes made by Raychem® (Tyco International Inc., Princeton, N.J., U.S. A.). Increased bulk resistance may allow voltage along the sleeve of the electrode to be distributed, thus decreasing the current density at the end of the electrode.

[1464] Many different types of wells or wellbores may be used to treat the hydrocarbon containing formation using the in situ heat treatment process. In some embodiments, vertical and/or substantially vertical wells are used to treat the formation. In some embodiments, horizontal (such as J-shaped wells and/or L-shaped wells), and/or u-shaped wells are used to treat the formation. In some embodiments, combinations of horizontal wells, vertical wells, and/or other combinations are used to treat the formation. In certain embodiments, wells extend through the overburden of the formation to a hydrocarbon containing layer of the formation. Heat in the wells may be lost to the overburden. In certain embodiments, surface and/or overburden infrastructures used to support heaters and/or production equipment in horizontal wellbores and/or u-shaped wellbores are large in size and/or numerous.

[1465] In certain embodiments, heaters, heater power sources, production equipment, supply lines, and/or other heater or production support equipment are positioned in tunnels to enable smaller sized heaters and/or smaller sized equipment to be used to treat the formation. Positioning such equipment and/or structures in tunnels may also reduce energy costs for treating the formation, reduce emissions from the treatment process, facilitate heating system installation, and/or reduce heat loss to the overburden as compared to hydrocarbon recovery processes that utilize surface based equipment. The tunnels may be, for example, substantially horizontal tunnels and/or inclined tunnels. U.S. Published Patent Application Nos. 2007/0044957 to Watson et al.; 2008/0017416 to Watson et al.; and 2008/0078552 to Donnelly et al. describe methods of drilling from a shaft for underground recovery of hydrocarbons and methods of underground recovery of hydrocarbons.

[1466] In certain embodiments, tunnels and/or shafts are used in combination with wells to treat the hydrocarbon containing formation using the in situ heat treatment process. FIG. 206 depicts a perspective view of underground treatment system 1028. Underground treatment system 1028 may be used to treat hydrocarbon layer 388 using the in situ heat treatment process. In certain embodiments, underground treatment system 1028 includes shafts 1030, utility shafts 1032, tunnels 1034A, tunnels 1034B, and wellbores 490. Tunnels 1034A, 1034B may be located in overburden 400, an underburden, a non-hydrocarbon containing layer, or a low hydrocarbon content layer of the formation. In some embodiments, tunnels 1034A, 1034B are located in a rock layer of the formation. In some embodiments, tunnels 1034A, 1034B are located in an impermeable portion of the formation. For example, tunnels 1034A, 1034B may be located in a portion of the formation having a permeability of at most about 1 millidarcy.

[1467] Shafts 1030 and/or utility shafts 1032 may be formed and strengthened (for example, supported to inhibit collapse) using methods known in the art. For example, shafts 1030 and/or utility shafts 1032 may be formed using blind and raised bore drilling technologies using mud weight and lining

to support the shafts. Conventional techniques may be used to raise and lower equipment in the shafts and/or to provide utilities through the shafts.

[1468] Tunnels **1034A**, **1034B** may be formed and strengthened (for example, supported to inhibit collapse) using methods known in the art. For example, tunnels **1034A**, **1034B** may be formed using road-headers, drill and blast, tunnel boring machine, and/or continuous miner technologies to form the tunnels. Tunnel strengthening may be provided by, for example, roof support, mesh, and/or shot-crete. Tunnel strengthening may inhibit tunnel collapse and/or to inhibit movement of the tunnels during heat treatment of the formation.

[1469] In certain embodiments, the status of tunnels **1034A**, tunnels **1034B**, shafts **1030**, and/or utility shafts **1032** are monitored for changes in structure or integrity of the tunnels or shafts. For example, conventional mine survey technologies may be used to continuously monitor the structure and integrity of the tunnels and/or shafts. In addition, systems may be used to monitor changes in characteristics of the formation that may affect the structure and/or integrity of the tunnels or shafts.

[1470] In certain embodiments, tunnels **1034A**, **1034B** are substantially horizontal or inclined in the formation. In some embodiments, tunnels **1034A** extend along the line of shafts **1030** and utility shafts **1032**. Tunnels **1034B** may connect between tunnels **1034A**. In some embodiments, tunnels **1034B** allow cross-access between tunnels **1034A**. In some embodiments, tunnels **1034B** are used to cross-connect production between tunnels **1034A** below the surface of the formation.

[1471] Tunnels **1034A**, **1034B** may have cross-section shapes that are rectangular, circular, elliptical, horseshoe-shaped, irregular-shaped, or combinations thereof. Tunnels **1034A**, **1034B** may have cross-sections large enough for personnel, equipment, and/or vehicles to pass through the tunnels. In some embodiments, tunnels **1034A**, **1034B** have cross-sections large enough to allow personnel and/or vehicles to freely pass by equipment located in the tunnels. In some embodiments, the tunnels described in embodiments herein have an average diameter of at least 1 m, at least 2 m, at least 5 m, or at least 10 m.

[1472] In certain embodiments, shafts **1030** and/or utility shafts **1032** connect with tunnels **1034A** in overburden **400**. In some embodiments, shafts **1030** and/or utility shafts **1032** connect with tunnels **1034A** in another layer of the formation. Shafts **1030** and/or utility shafts **1032** may be sunk or formed using methods known in the art for drilling and/or sinking mine shafts. In certain embodiments, shafts **1030** and/or utility shafts **1032** connect with tunnels **1034A** in overburden **400** and/or hydrocarbon layer **388** to surface **404**. In some embodiments, shafts **1030** and/or utility shafts **1032** extend into hydrocarbon layer **388**. For example, shafts **1030** may include production conduits and/or other production equipment to produce fluids from hydrocarbon layer **388** to surface **404**.

[1473] In certain embodiments, shafts **1030** and/or utility shafts **1032** are substantially vertical or slightly angled from vertical. In certain embodiments, shafts **1030** and/or utility shafts **1032** have cross-sections large enough for personnel, equipment, and/or vehicles to pass through the shafts. In some embodiments, shafts **1030** and/or utility shafts **1032** have circular cross-sections. Shafts **1030** and/or utility shafts **1032**

may have an average cross-sectional diameter of at least 0.5 m, at least 1 m, at least 2 m, at least 5 m, or at least 10 m.

[1474] In certain embodiments, the distance between two shafts **1030** is between 500 m and 5000 m, between 1000 m and 4000 m, or between 2000 m and 3000 m. In certain embodiments, the distance between two utility shafts **1032** is between 100 m and 1000 m, between 250 m and 750 m, or between 400 m and 600 m.

[1475] In certain embodiments, shafts **1030** are larger in cross-section than utility shafts **1032**. Shafts **1030** may allow access to tunnels **1034A** for large ventilation, materials, equipment, vehicles, and personnel. Utility shafts **1032** may provide service corridor access to tunnels **1034A** for equipment or structures such as, but not limited to, power supply legs, production risers, and/or ventilation openings. In some embodiments, shafts **1030** and/or utility shafts **1032** include monitoring and/or sealing systems to monitor and assess gas levels in the shafts and to seal off the shafts if needed.

[1476] FIG. 207 depicts an exploded perspective view of a portion of underground treatment system **1028** and tunnels **1034A**. In certain embodiments, tunnels **1034A** include heater tunnels **1036** and/or utility tunnels **1038**. In some embodiments, tunnels **1034A** include additional tunnels such as access tunnels and/or service tunnels. FIG. 208 depicts an exploded perspective view of a portion of underground treatment system **1028** and tunnels **1034A**. Tunnels **1034A**, as shown in FIG. 208, may include heater tunnels **1036**, utility tunnels **1038**, and/or access tunnels **1040**.

[1477] In certain embodiments, as shown in FIG. 207, wellbores **490** extend from heater tunnels **1036**. Wellbores **490** may include, but not be limited to, heater wells, heat source wells, production wells, injection wells (for example, steam injection wells), and/or monitoring wells. Heaters and/or heat sources that may be located in wellbores **490** include, but are not limited to, electric heaters, oxidation heaters (gas burners), heaters circulating a heat transfer fluid, closed looped molten salt circulating systems, pulverized coal systems, and/or joule heat sources (heating of the formation using electrical current flow between heat sources having electrically conducting material in two wellbores in the formation). The wellbores used for joule heat sources may extend from the same tunnel (for example, substantially parallel wellbores extending between two tunnels with electrical current flowing between the wellbores) or from different tunnels (for example, wellbores extending from two different tunnels that are spaced to allow electrical current flow between the wellbores).

[1478] Heating the formation with heat sources having electrically conducting material may increase permeability in the formation and/or lower viscosity of hydrocarbons in the formation. Heat sources with electrically conducting material may allow current to flow through the formation from one heat source to another heat source. Heating using current flow or "joule heating" through the formation may heat portions of the hydrocarbon layer in a shorter amount of time relative to heating the hydrocarbon layer using conductive heating between heaters spaced apart in the formation.

[1479] In certain embodiments, subsurface formations (for example, tar sands or heavy hydrocarbon formations) include dielectric media. Dielectric media may exhibit conductivity, relative dielectric constant, and loss tangents at temperatures below 100° C. Loss of conductivity, relative dielectric constant, and dissipation factor may occur as the formation is heated to temperatures above 100° C. due to the loss of

moisture contained in the interstitial spaces in the rock matrix of the formation. To prevent loss of moisture, formations may be heated at temperatures and pressures that minimize vaporization of water. In some embodiments, conductive solutions are added to the formation to help maintain the electrical properties of the formation. Heating the formation at low temperatures may require the hydrocarbon layer to be heated for long periods of time to produce permeability and/or injectivity.

[1480] In some embodiments, formations are heated using joule heating to temperatures and pressures that vaporize the water and/or conductive solutions. Material used to produce the current flow, however, may become damaged due to heat stress and/or loss of conductive solutions may limit heat transfer in the layer. In addition, when using current flow or joule heating, magnetic fields may form. Due to the presence of magnetic fields, non-ferromagnetic materials may be desired for overburden casings. Although many methods have been described for heating formations using joule heating, efficient and economic methods of heating and producing hydrocarbons using heat sources with electrically conductive material are needed.

[1481] In some embodiments, heat sources that include electrically conductive materials are positioned in the hydrocarbon layer. Electrically resistive portions of the hydrocarbon layer may be heated by electrical current that flows from the heat sources and through the layer. Positioning of electrically conductive heat sources in the hydrocarbon layer at depths sufficient to minimize loss of conductive solutions may allow hydrocarbon layers to be heated at relatively high temperatures over a period of time with minimal loss of water and/or conductive solutions.

[1482] Introduction of heat sources into hydrocarbon layer 388 through heater tunnels 1036 allows the hydrocarbon layer to be heated without significant heat losses to overburden 400. Being able to provide heat mainly to hydrocarbon layer 388 with low heat losses in the overburden may enhance heater efficiency. Using tunnels to provide heater sections only in the hydrocarbon layer, and not requiring heater wellbore sections in the overburden, may decrease heater costs by at least 30%, at least 50%, at least 60%, or at least 70% as compared to heater costs using heaters that have sections passing through the overburden.

[1483] In some embodiments, providing heaters through tunnels allows higher heat source densities in the hydrocarbon layer 388 to be obtained. Higher heat source densities may result in faster production of hydrocarbons from the formation. Closer spacing of heaters may be economically beneficial due to a significantly lower cost per additional heater. For example, heaters located in the hydrocarbon layer of a tar sands formation by drilling through the overburden are typically spaced about 12 m apart. Installing heaters from tunnels may allow heaters to be spaced about 8 m apart in the hydrocarbon layer. The closer spacing may accelerate first production to about 2 years as compared to the 5 years for first production obtained from heaters that are spaced 12 m apart and accelerate completion of production to about 5 years from about 8 years. This acceleration in first production may reduce the heating requirement 5% or more.

[1484] In certain embodiments, subsurface connections for heaters or heat sources are made in heater tunnels 1036. Connections that are made in heater tunnels 1036 include, but are not limited to, insulated electrical connections, physical support connections, and instrumental/diagnostic connec-

tions. For example, electrical connection may be made between electric heater elements and bus bars located in heater tunnels 1036. The bus bars may be used to provide electrical connection to the ends of the heater elements. In certain embodiments, connections made in heater tunnels 1036 are made at a certain safety level. For example, the connections are made such that there is little or no explosion risk (or other potential hazards) in the heater tunnels because of gases from the heat sources or the heat source wellbores that may migrate to heater tunnels 1036. In some embodiments, heater tunnels 1036 are ventilated to the surface or another area to lower the explosion risk in the heater tunnels. For example, heater tunnels 1036 may be vented through utility shafts 1032.

[1485] In certain embodiments, heater connections are made between heater tunnels 1036 and utility tunnels 1038. For example, electrical connections for electric heaters extending from heater tunnels 1036 may extend through the heater tunnels into utility tunnels 1038. These connections may be substantially sealed such that there is little or no leaking between the tunnels either through or around the connections.

[1486] In certain embodiments, utility tunnels 1038 include power equipment or other equipment necessary to operate heat sources and/or production equipment. In certain embodiments, transformers 1042 and voltage regulators 1044 are located in utility tunnels 1038. Locating transformers 1042 and voltage regulators 1044 in the subsurface allows high-voltages to be transported directly into the overburden of the formation to increase the efficiency of providing power to heaters in the formation.

[1487] Transformers 1042 may be, for example, gas insulated, water cooled transformers such as SF₆ gas-insulated power transformers available from Toshiba Corporation (Tokyo, Japan). Such transformers may be high efficiency transformers. These transformers may be used to provide electricity to multiple heaters in the formation. The higher efficiency of these transformers reduces water cooling requirements for the transformers. Reducing the water cooling requirements of the transformers allows the transformers to be placed in small chambers without the need for extra cooling to keep the transformers from overheating. Water cooling instead of air cooling allows more heat per volume of cooling fluid to be transported to the surface versus air cooling. Using gas-insulated transformers may eliminate the use of flammable oils that may be hazardous in the underground environment.

[1488] In some embodiments, voltage regulators 238 are distribution type voltage regulators to control the voltage distributed to heat sources in the tunnels. In some embodiments, transformers 236 are used with load tap changers to control the voltage distributed to heat sources in the tunnels. In some embodiments, variable voltage, load tap changing transformers located in utility tunnels 232 are used to distribute electrical power to, and control the voltage of, heat sources in the tunnels. Transformers 236, voltage regulators 238, load tap changers 1042, and/or variable voltage, load tap changing transformers may control the voltage distributed to either groups or banks of heat sources in the tunnels or individual heat sources. Controlling the voltage distributed to a group of heat sources provides block control for the group of heat sources. Controlling the voltage distributed to individual heat sources provides individual heat source control.

[1489] In some embodiments, transformers 1042 and/or voltage regulators 1044 are located in side chambers of utility

tunnels **1038**. Locating transformers **1042** and/or voltage regulators **1044** in side chambers moves the transformers and/or voltage regulators out of the way of personnel, equipment, and/or vehicles moving through utility tunnels **1038**. Supply lines (for example, supply lines **204** depicted in FIG. **214**) in utility shaft **1032** may supply power to voltage regulators **1044** and transformers **1042** in utility tunnels **1038**.

[**1490**] In some embodiments, such as shown in FIG. **207**, voltage regulators **1044** are located in power chambers **1046**. Power chambers **1046** may connect to utility tunnels **1038** or be side chambers of the utility tunnels. Power may be brought into power chambers **1046** through utility shafts **1032**. Use of power chambers **1046** may allow easier, quicker, and/or more effective maintenance, repair, and/or replacement of the connections made to heat sources in the subsurface.

[**1491**] In certain embodiments, sections of heater tunnels **1036** and utility tunnels **1038** are interconnected by connecting tunnels **1048**. Connecting tunnels **1048** may allow access between heater tunnels **1036** and utility tunnels **1038**. Connecting tunnels **1048** may include airlocks or other structures to provide a seal that can be opened and closed between heater tunnels **1036** and utility tunnels **1038**.

[**1492**] In some embodiments, heater tunnels **1036** include pipelines **208** or other conduits. In some embodiments, pipelines **208** are used to produce fluids (for example, formation fluids such as hydrocarbon fluids) from production wells or heater wells coupled to heater tunnels **1036**. In some embodiments, pipelines **208** are used to provide fluids used in production wells or heater wells (for example, heat transfer fluids for circulating fluid heaters or gas for gas burners). Pumps and associated equipment **1050** for pipelines **208** may be located in pipeline chambers **1052** or other side chambers of the tunnels. In some embodiments, pipeline chambers **1052** are isolated (sealed off) from heater tunnels **1038**. Fluids may be provided to and/or removed from pipeline chambers **1052** using risers and/or pumps located in utility shafts **1032**.

[**1493**] In some embodiments, heat sources are used in wellbores **490** proximate heater tunnels **1036** to control viscosity of formation fluids being produced from the formation. The heat sources may have various lengths and/or provide different amounts of heat at different locations in the formation. In some embodiments, the heat sources are located in wellbores **490** used for producing fluids from the formation (for example, production wells).

[**1494**] As shown in FIG. **206**, wellbores **490** may extend between tunnels **1034A** in hydrocarbon layer **388**. Tunnels **1034A** may include one or more of heater tunnels **1036**, utility tunnels **1038**, and/or access tunnels **1040**. In some embodiments, access tunnels **1040** are used as ventilation tunnels. It should be understood that the any number of tunnels and/or any order of tunnels may be used as contemplated or desired.

[**1495**] In some embodiments, heated fluid may flow through wellbores **490** or heat sources that extend between tunnels **1034A**. For example, heated fluid may flow between a first heater tunnel and a second heater tunnel. The second tunnel may include a production system that is capable of removing the heated fluids from the formation to the surface of the formation. In some embodiments, the second tunnel includes equipment that collects heated fluids from at least two wellbores. In some embodiments, the heated fluids are moved to the surface using a lift system. The lift system may be located in utility shaft **1032** or a separate production wellbore.

[**1496**] Production well lift systems may be used to efficiently transport formation fluid from the bottom of the production wells to the surface. Production well lift systems may provide and maintain the maximum required well drawdown (minimum reservoir producing pressure) and producing rates. The production well lift systems may operate efficiently over a wide range of high temperature/multiphase fluids (gas/vapor/steam/water/hydrocarbon liquids) and production rates expected during the life of a typical project. Production well lift systems may include dual concentric rod pump lift systems, chamber lift systems and other types of lift systems.

[**1497**] FIG. **209** depicts a side view representation of an embodiment for flowing heated fluid in heat sources **202** between tunnels **1034A**. FIG. **210** depicts a top view representation of the embodiment depicted in FIG. **209**. Circulation system **706** may circulate heated fluid (for example, molten salt) through heat sources **202**. Shafts **1032** and tunnels **1034A** may be used to provide the heated fluid to the heat sources and return the heated fluid from the heat sources. Large diameter piping may be used in shafts **1032** and tunnels **1034A**. Large diameter piping may minimize pressure drops in transporting the heated fluid through the overburden of the formation. Piping in shafts **1032** and tunnels **1034A** may be insulated to inhibit heat losses in the overburden.

[**1498**] FIG. **211** depicts another perspective view of an embodiment of underground treatment system **1028** with wellbores **490** extending between tunnels **1034A**. Heat sources or heaters may be located in wellbores **490**. In certain embodiments, wellbores **490** extend from wellbore chambers **1054**. Wellbore chambers **1054** may be connected to the sides of tunnels **1034A** or be side chambers of the tunnels.

[**1499**] FIG. **212** depicts a top view of an embodiment of tunnel **1034A** with wellbore chambers **1054**. In certain embodiments, power chambers **1046** are connected to utility tunnel **1038**. Transformers **1042** and/or other power equipment may be located in power chambers **1046**.

[**1500**] In certain embodiments, tunnel **1034A** includes heater tunnel **1036** and utility tunnel **1038**. Heater tunnel **1036** may be connected to utility tunnel **1038** with connecting tunnel **1048**. Wellbore chambers **1054** are connected to heater tunnel **1036**. In certain embodiments, wellbore chambers **1054** include heater wellbore chambers **1054A** and adjunct wellbore chambers **1054B**. Heat sources **202** (for example, heaters) may extend from heater wellbore chambers **1054A**. Heat sources **202** may be located in wellbores extending from heater wellbore chambers **1054A**.

[**1501**] In certain embodiments, heater wellbore chambers **1054A** have angled side walls with respect to heater tunnel **1036** to allow heat sources to be installed into the chambers more easily. The heaters may have limited bending capability and the angled walls may allow the heaters to be installed into the chambers without overbending the heaters.

[**1502**] In certain embodiments, barrier **1056** seals off heater wellbore chambers **1054A** from heater tunnel **1036**. Barrier **1056** may be a fire and/or blast resistant barrier (for example, a concrete wall). In some embodiments, barrier **1056** includes an access port (for example, an access door) to allow entry into the chambers. In some embodiments, heater wellbore chambers **1054A** are sealed off from heater tunnel **1036** after heat sources **202** have been installed. Utility shaft **1032** may provide ventilation into heater wellbore chambers **1054A**. In some embodiments, utility shaft **1032** is used to provide a fire or blast suppression fluid into heater wellbore chambers **1054A**.

[1503] In certain embodiments, adjunct wellbores **490A** extend from adjunct wellbore chambers **1054B**. Adjunct wellbores **490A** may include wellbores used as, for example, infill wellbores (repair wellbores) or intervention wellbores for killing leaks and/or monitoring wellbores. Barrier **1056** may seal off adjunct wellbore chambers **1054B** from heater tunnel **1036**. In some embodiments, heater wellbore chambers **1054A** and/or adjunct wellbore chambers **1054B** are cemented in (the chambers are filled with cement). Filling the chambers with cement substantially seals off the chambers from inflow or outflow of fluids.

[1504] As shown in FIGS. **206** and **211**, wellbores **490** may be formed between tunnels **1034A**. Wellbores **490** may be formed substantially vertically, substantially horizontally, or inclined in hydrocarbon layer **388** by drilling into the hydrocarbon layer from tunnels **1034A**. Wellbores **490** may be formed using drilling techniques known in the art. For example, wellbores **490** may be formed by pneumatic drilling using coiled tubing available from Penguin Automated Systems (Naughton, Ontario, Canada).

[1505] Drilling wellbores **490** from tunnels **1034A** may increase drilling efficiency and decrease drilling time and allow for longer wellbores because the wellbores do not have to be drilled through overburden **400**. Tunnels **1034A** may allow large surface footprint equipment to be placed in the subsurface instead of at the surface. Drilling from tunnels **1034A** and subsequent placement of equipment and/or connections in the tunnels may reduce a surface footprint as compared to conventional surface drilling methods that use surface based equipment and connections.

[1506] Using shafts and tunnels in combination with the in situ heat treatment process for treating the hydrocarbon containing formation may be beneficial because the overburden section is eliminated from wellbore construction, heater construction, and/or drilling requirements. In some embodiments, at least a portion of the shafts and tunnels are located below aquifers in or above the hydrocarbon containing formation. Locating the shafts and tunnels below the aquifers may reduce contamination risk to the aquifers, and/or may simplify abandonment of the shafts and tunnels after treatment of the formation.

[1507] In certain embodiments, underground treatment system **1028** (depicted in FIGS. **206**, **207**, **211**, **215**, and **214**) includes one or more seals to seal the tunnels and shafts from the formation pressure and formation fluids. For example, the underground treatment system may include one or more impermeable barriers to seal personnel workspace from the formation. In some embodiments, wellbores are sealed off with impermeable barriers to the tunnels and shafts to inhibit fluids from entering the tunnels and shafts from the wellbores. In some embodiments, the impermeable barriers include cement or other packing materials. In some embodiments, the seals include valves or valve systems, airlocks, or other sealing systems known in the art. The underground treatment system may include at least one entry/exit point to the surface for access by personnel, vehicles, and/or equipment.

[1508] FIG. **213** depicts a top view of an embodiment of development of tunnel **1034A**. Heater tunnel **1036** may include heat source section **1058**, connecting section **1060**, and/or drilling section **1062** as the heater tunnel is being formed left to right. From heat source section **1058**, wellbores **490** have been formed and heat sources have been introduced into the wellbores. In some embodiments, heat source section **1058** is considered a hazardous confined space. Heat source

section **1058** may be isolated from other sections in heater tunnel **1036** and/or utility tunnel **1038** with material impermeable to hydrocarbon gases and/or hydrogen sulfide. For example, cement or another impermeable material may be used to seal off heat source section **1058** from heater tunnel **1036** and/or utility tunnel **1038**. In some embodiments, impermeable material is used to seal off heat source section **1058** from the heated portion of the formation to inhibit formation fluids or other hazardous fluids from entering the heat source section. In some embodiments, at least 30 m, at least 40 m, or at least 50 m of wellbore is between the heat sources and heater tunnel **1036**. In some embodiments, shaft **1030** proximate to heater tunnel **1036** is sealed (for example, filled with cement) after heating has been initiated in the hydrocarbon layer to inhibit gas or other fluids from entering the shaft.

[1509] In some embodiments, heaters controls may be located in utility tunnel **1038**. In some embodiments, utility tunnel **1038** includes electrical connections, combustors, tanks, and/or pumps necessary to support heaters and/or heat transport systems. For example, transformers **1042** may be located in utility tunnel **1038**.

[1510] Connecting section **1060** may be located after heat source section **1058**. Connecting section **1060** may include space for performing operations necessary for installing the heat sources and/or connecting heat sources (for example, making electrical connections to the heaters). In some embodiments, connections and/or movement of equipment in connecting section **1060** is automated using robotics or other automation techniques. Drilling section **1062** may be located after connecting section **1060**. Additional wellbores may be dug and/or the tunnel may be extended in drilling section **1062**.

[1511] In certain embodiments, operations in heat source section **1058**, connecting section **1060**, and/or drilling section **1062** are independent of each other. Heat source section **1058**, connecting section **1060**, and/or production section **1062** may have dedicated ventilation systems and/or connections to utility tunnel **1038**. Connecting tunnels **1048** may allow access and egress to heat source section **1058**, connecting section **1060**, and/or drilling section **1062**.

[1512] In certain embodiments, connecting tunnels **1048** include airlocks **1064** and/or other barriers. Airlocks **1064** may help regulate the relative pressures such that the pressure in heat source section **1058** is less than the air pressure in connecting section **1060**, which is less than the air pressure in drilling section **1062**. Air flow may move into heat source section **1058** (the most hazardous area) to reduce the probability of a flammable atmosphere in utility tunnel **1038**, connecting section **1060**, and/or drilling section **1062**. Airlocks **1064** may include suitable gas detection and alarms to ensure transformers or other electrical equipment are de-energized in the event that an unsafe flammable limit is encountered in the utility tunnel **1038** (for example, less than one-half of the lower flammable limit). Automated controls may be used to operate airlocks **1064** and/or the other barriers. Airlocks **1064** may be operated to allow personnel controlled access and/or egress during normal operations and/or emergency situations.

[1513] In certain embodiments, heat sources located in wellbores extending from tunnels are used to heat the hydrocarbon layer. The heat from the heat sources may mobilize hydrocarbons in the hydrocarbon layer and the mobilized hydrocarbons flow towards production wells. Production

wells may be positioned in the hydrocarbon layer below, adjacent, or above the heat sources to produce the mobilized fluids. In some embodiments, formation fluids may gravity drain into tunnels located in the hydrocarbon layer. Production systems may be installed in the tunnels (for example, pipeline 208 depicted in FIG. 207). The tunnel production systems may be operated from surface facilities and/or facilities in the tunnel Piping, holding facilities, and/or production wells may be located in a production portion of the tunnels to be used to produce the fluids from the tunnels. The production portion of the tunnels may be sealed with an impervious material (for example, cement or a steel liner). The formation fluids may be pumped to the surface through a riser and/or vertical production well located in the tunnels. In some embodiments, formation fluids from multiple horizontal production wellbores drain into one vertical production well located in one tunnel. The formation fluids may be produced to the surface through the vertical production well.

[1514] In some embodiments, a production wellbore extending directly from the surface to the hydrocarbon layer is used to produce fluids from the hydrocarbon layer. FIG. 214 depicts production well 206 extending from the surface into hydrocarbon layer 388. In certain embodiments, production well 206 is substantially horizontally located in hydrocarbon layer 388. Production well 206 may, however, have any orientation desired. For example, production well 206 may be a substantially vertical production well.

[1515] In some embodiments, as shown in FIG. 214, production well 206 extends from the surface of the formation and heat sources 202 extend from tunnels 1034A in overburden 400 or another impermeable layer of the formation. Having the production well separated from the tunnels used to provide heat sources into the formation may reduce risks associated with having hot formation fluids (for example, hot hydrocarbon fluids) in the tunnels and near electrical equipment or other heater equipment. In some embodiments, the distance between the location of production wells on the surface and the location of fluid intakes, ventilation intakes, and/or other possible intakes into the tunnels below the surface is maximized to minimize the risk of fluids reentering the formation through the intakes.

[1516] In some embodiments, wellbores 490 interconnect with utility tunnels 1038 or other tunnels below the overburden of the formation. FIG. 215 depicts a side view of an embodiment of underground treatment system 1028. In certain embodiments, wellbores 490 are directionally drilled to utility tunnels 1038 in hydrocarbon layer 388. Wellbores 490 may be directional drilled from the surface or from tunnels located in overburden 400. Directional drilling to intersect utility tunnel 1038 in hydrocarbon layer 388 may be easier than directional drilling to intersect another wellbore in the formation. Drilling equipment such as, but not limited to, magnetic transmission equipment, magnetic sensing equipment, acoustic transmission equipment, and acoustic sensing equipment may be located in utility tunnels 1038 and used for directional drilling of wellbores 490. The drilling equipment may be removed from utility tunnels 1038 after directional drilling is completed. In some embodiments, utility tunnels 1038 are later used for collection and/or production of fluids from the formation during the in situ heat treatment process.

EXAMPLES

[1517] Non-restrictive examples are set forth below.

Samples Using Fitting Embodiment Depicted in FIG. 38

[1518] Samples using an embodiment of fitting 422 similar to the embodiment depicted in FIG. 38 were fabricated using

a hydraulic compaction machine with a medium voltage insulated conductor suitable for use as a subsurface heater on one side of the fitting and a medium voltage insulated conductor suitable for use as an overburden cable on the other side of the fitting. Magnesium oxide was used as the electrically insulating material in the fittings. The samples were 6 feet long from the end of one mineral insulated conductor to the other. Prior to electrical testing, the samples were placed in a 6½ ft long oven and dried at 850° F. for 30 hours. Upon cooling to 150° F., the ends of the mineral insulated conductors were sealed using epoxy. The samples were then placed in an oven 3 feet long to heat up the samples and voltage was applied to the samples using a 5 kV (max) hipot (high potential) tester, which was able to measure both total and real components of the leakage current. Three thermocouples were placed on the samples and averaged for temperature measurement. The samples were placed in the oven with the fitting at the center of the oven. Ambient DC (direct current) responses and AC (alternating current) leakage currents were measured using the hipot tester.

[1519] A total of eight samples were tested at about 1000° F. and voltages up to 5 kV. One individual sample tested at 5 kV had a leakage current of 2.28 mA, and another had a leakage current of 6.16 mA. Three more samples with conductors connected together in parallel were tested to 5 kV and had an aggregate leakage current of 11.7 mA, or 3.9 mA average leakage current per cable, and the three samples were stable. Three other samples with conductors connected together in parallel were tested to 4.4 kV and had an aggregate leakage current of 4.39 mA, but they could not withstand a higher voltage without tripping the hipot tester (which occurs when leakage current exceeds 40 mA). One of the samples tested to 5 kV underwent further testing at ambient temperature to breakdown. Breakdown occurred at 11 kV.

[1520] A total of eleven more samples were fabricated for additional breakdown testing at ambient temperature. Three of the samples had insulated conductors prepared with the mineral insulation cut perpendicular to the sheath while the eight other samples had insulated conductors prepared with the mineral insulation cut at a 30° angle to the sheath. Of the first three samples with the perpendicular cut, the first sample withstood up to 10.5 kV before breakdown, the second sample withstood up to 8 kV before breakdown, while the third sample withstood only 500 V before breakdown, which suggested a flaw in fabrication of the third sample. Of the eight samples with the 30° cut, two samples withstood up to 10 kV before breakdown, three samples withstood between 8 kV and 9.5 kV before breakdown, and three samples withstood no voltage or less than 750 V, which suggested flaws in fabrication of these three samples.

Samples Using Fitting Embodiment Depicted in FIG. 41B

[1521] Three samples using an embodiment of fitting 442 similar to the embodiment depicted in FIG. 41B were made. The samples were made with two insulated conductors instead of three and were tested to breakdown at ambient temperature. One sample withstood 5 kV before breakdown, a second sample withstood 4.5 kV before breakdown, and a third sample could withstand only 500 V, which suggested a flaw in fabrication.

Samples Using Fitting Embodiment Depicted in FIGS. 47 and 48

[1522] Samples using an embodiment of fitting 470 similar to the embodiment depicted in FIGS. 47 and 48 were used to

connect two insulated conductors with 1.2" outside diameters and 0.7" diameter conductors. MgO powder (Muscle Shoals Minerals, Greenville, Tenn., U.S.A.) was used as the electrically insulating material. The fitting was made from 347H stainless steel tubing and had an outside diameter of 1.5" with a wall thickness of 0.125" and a length of 7.0". The samples were placed in an oven and heated to 1050° F. and cycled through voltages of up to 3.4 kV. The samples were found to viable at all the voltages but could not withstand higher voltages without tripping the hipot tester.

[1523] In a second test, samples similar to the ones described above were subjected to a low cycle fatigue-bending test and then tested electrically in the oven. These samples were placed in the oven and heated to 1050° F. and cycled through voltages of 350 V, 600 V, 800 V, 1000 V, 1200 V, 1400 V, 1600 V, 1900 V, 2200 V, and 2500 V. Leakage current magnitude and stability in the samples were acceptable up to voltages of 1900 V. Increases in the operating range of the fitting may be feasible using further electric field intensity reduction methods such as tapered, smoothed, or rounded edges in the fitting or adding electric field stress reducers inside the fitting.

Tar Sands Simulation

[1524] A STARS simulation was used to simulate heating of a tar sands formation using the heater well pattern depicted in FIG. 99. The heaters had a horizontal length in the tar sands formation of 600 m. The heating rate of the heaters was about 750 W/m. Production well 206B, depicted in FIG. 99, was used at the production well in the simulation. The bottom hole pressure in the horizontal production well was maintained at about 690 kPa. The tar sands formation properties were based on Athabasca tar sands. Input properties for the tar sands formation simulation included: initial porosity equals 0.28; initial oil saturation equals 0.8; initial water saturation equals 0.2; initial gas saturation equals 0.0; initial vertical permeability equals 250 millidarcy; initial horizontal permeability equals 500 millidarcy; initial K_v/K_h equals 0.5; hydrocarbon layer thickness equals 28 m; depth of hydrocarbon layer equals 587 m; initial reservoir pressure equals 3771 kPa; distance between production well and lower boundary of hydrocarbon layer equals 2.5 meter; distance of topmost heaters and overburden equals 9 meter; spacing between heaters equals 9.5 meter; initial hydrocarbon layer temperature equals 18.6° C.; viscosity at initial temperature equals 53 Pa·s (53000 cp); and gas to oil ratio (GOR) in the tar equals 50 standard cubic feet/standard barrel. The heaters were constant wattage heaters with a highest temperature of 538° C. at the sand face and a heater power of 755 W/m. The heater wells had a diameter of 15.2 cm.

[1525] FIG. 216 depicts a temperature profile in the formation after 360 days using the STARS simulation. The hottest spots are at or near heaters 412. The temperature profile shows that portions of the formation between the heaters are warmer than other portions of the formation. These warmer portions create more mobility between the heaters and create a flow path for fluids in the formation to drain downwards towards the production wells.

[1526] FIG. 217 depicts an oil saturation profile in the formation after 360 days using the STARS simulation. Oil saturation is shown on a scale of 0.00 to 1.00 with 1.00 being 100% oil saturation. The oil saturation scale is shown in the sidebar. Oil saturation, at 360 days, is somewhat lower at heaters 412 and production well 206B. FIG. 218 depicts the

oil saturation profile in the formation after 1095 days using the STARS simulation. Oil saturation decreased overall in the formation with a greater decrease in oil saturation near the heaters and in between the heaters after 1095 days. FIG. 219 depicts the oil saturation profile in the formation after 1470 days using the STARS simulation. The oil saturation profile in FIG. 219 shows that the oil is mobilized and flowing towards the lower portions of the formation. FIG. 220 depicts the oil saturation profile in the formation after 1826 days using the STARS simulation. The oil saturation is low in a majority of the formation with some higher oil saturation remaining at or near the bottom of the formation in portions below production well 206B. This oil saturation profile shows that a majority of oil in the formation has been produced from the formation after 1826 days.

[1527] FIG. 221 depicts the temperature profile in the formation after 1826 days using the STARS simulation. The temperature profile shows a relatively uniform temperature profile in the formation except at heaters 412 and in the extreme (corner) portions of the formation. The temperature profile shows that a flow path has been created between the heaters and to production well 206B.

[1528] FIG. 222 depicts oil production rate 1066 (bbl/day) (left axis) and gas production rate 1068 (ft³/day)(right axis) versus time (years). The oil production and gas production plots show that oil is produced at early stages (0-1.5 years) of production with little gas production. The oil produced during this time was most likely heavier mobilized oil that is unpyrolyzed. After about 1.5 years, gas production increased sharply as oil production decreased sharply. The gas production rate quickly decreased at about 2 years. Oil production then slowly increased up to a maximum production around about 3.75 years. Oil production then slowly decreased as oil in the formation was depleted.

[1529] From the STARS simulation, the ratio of energy out (produced oil and gas energy content) versus energy in (heater input into the formation) was calculated to be about 12 to 1 after about 5 years. The total recovery percentage of oil in place was calculated to be about 60% after about 5 years. Thus, producing oil from a tar sands formation using an embodiment of the heater and production well pattern depicted in FIG. 99 may produce high oil recoveries and high energy out to energy in ratios.

Tar Sands Example

[1530] A STARS simulation was used in combination with experimental analysis to simulate an in situ heat treatment process of a tar sands formation. Heating conditions for the experimental analysis were determined from reservoir simulations. The experimental analysis included heating a cell of tar sands from the formation to a selected temperature and then reducing the pressure of the cell (blow down) to 100 psig. The process was repeated for several different selected temperatures. While heating the cells, formation and fluid properties of the cells were monitored while producing fluids to maintain the pressure below an optimum pressure of 12 MPa before blow down and while producing fluids after blow down (although the pressure may have reached higher pressures in some cases, the pressure was quickly adjusted and does not affect the results of the experiments). FIGS. 223-230 depict results from the simulation and experiments.

[1531] FIG. 223 depicts weight percentage of original bitumen in place (OBIP) (left axis) and volume percentage of OBIP (right axis) versus temperature (° C.). The term "OBIP"

refers, in these experiments, to the amount of bitumen that was in the laboratory vessel with 100% being the original amount of bitumen in the laboratory vessel. Plot 1070 depicts bitumen conversion (correlated to weight percentage of OBIP). Plot 1070 shows that bitumen conversion began to be significant at about 270° C. and ended at about 340° C. The bitumen conversion was relatively linear over the temperature range.

[1532] Plot 1072 depicts barrels of oil equivalent from producing fluids and production at blow down (correlated to volume percentage of OBIP). Plot 1074 depicts barrels of oil equivalent from producing fluids (correlated to volume percentage of OBIP). Plot 1076 depicts oil production from producing fluids (correlated to volume percentage of OBIP). Plot 1078 depicts barrels of oil equivalent from production at blow down (correlated to volume percentage of OBIP). Plot 1080 depicts oil production at blow down (correlated to volume percentage of OBIP). As shown in FIG. 223, the production volume began to significantly increase as bitumen conversion began at about 270° C. with a significant portion of the oil and barrels of oil equivalent (the production volume) coming from producing fluids and only some volume coming from the blow down.

[1533] FIG. 224 depicts bitumen conversion percentage (weight percentage of OBIP) (left axis) and oil, gas, and coke weight percentage (as a weight percentage of OBIP) (right axis) versus temperature (° C.). Plot 1082 depicts bitumen conversion (correlated to weight percentage of OBIP). Plot 1084 depicts oil production from producing fluids correlated to weight percentage of OBIP (right axis). Plot 1086 depicts coke production correlated to weight percentage of OBIP (right axis). Plot 1088 depicts gas production from producing fluids correlated to weight percentage of OBIP (right axis). Plot 1090 depicts oil production from blow down production correlated to weight percentage of OBIP (right axis). Plot 1092 depicts gas production from blow down production correlated to weight percentage of OBIP (right axis). FIG. 224 shows that coke production begins to increase at about 280° C. and maximizes around 340° C. FIG. 224 also shows that the majority of oil and gas production is from produced fluids with only a small fraction from blow down production.

[1534] FIG. 225 depicts API gravity (° (left axis) of produced fluids, blow down production, and oil left in place along with pressure (psig) (right axis) versus temperature (° C.). Plot 1094 depicts API gravity of produced fluids versus temperature. Plot 1096 depicts API gravity of fluids produced at blow down versus temperature. Plot 1098 depicts pressure versus temperature. Plot 1100 depicts API gravity of oil (bitumen) in the formation versus temperature. FIG. 225 shows that the API gravity of the oil in the formation remains relatively constant at about 10° API and that the API gravity of produced fluids and fluids produced at blow down increases slightly at blow down.

[1535] FIGS. 226A-D depict gas-to-oil ratios (GOR) in thousand cubic feet per barrel (Mcf/bbl) (y-axis) versus temperature (° C.) (x-axis) for different types of gas at a low temperature blow down (about 277° C.) and a high temperature blow down (at about 290° C.). FIG. 226A depicts the GOR versus temperature for carbon dioxide (CO₂). Plot 1102 depicts the GOR for the low temperature blow down. Plot 1104 depicts the GOR for the high temperature blow down. FIG. 226B depicts the GOR versus temperature for hydrocarbons. FIG. 226C depicts the GOR for hydrogen sulfide (H₂S).

FIG. 226D depicts the GOR for hydrogen (H₂). In FIGS. 226B-D, the GORs were approximately the same for both the low temperature and high temperature blow downs. The GORs for CO₂ (shown in FIGS. 226A-D) was different for the high temperature blow down and the low temperature blow down. The reason for the difference in the GORs for CO₂ may be that CO₂ was produced early (at low temperatures) by the hydrous decomposition of dolomite and other carbonate minerals and clays. At these low temperatures, there was hardly any produced oil so the GOR is very high because the denominator in the ratio is practically zero. The other gases (hydrocarbons, H₂S, and H₂) were produced concurrently with the oil either because they were all generated by the upgrading of bitumen (for example, hydrocarbons, H₂, and oil) or because they were generated by the decomposition of minerals (such as pyrite) in the same temperature range as that of bitumen upgrading. Thus, when the GOR was calculated, the denominator (oil) was non zero for hydrocarbons, H₂S, and H₂.

[1536] FIG. 227 depicts coke yield (weight percentage) (y-axis) versus temperature (° C.) (x-axis). Plot 1106 depicts bitumen and kerogen coke as a weight percent of original mass in the formation. Plot 1108 depicts bitumen coke as a weight percent of original bitumen in place (OBIP) in the formation. FIG. 227 shows that kerogen coke is already present at a temperature of about 260° C. (the lowest temperature cell experiment) while bitumen coke begins to form at about 280° C. and maximizes at about 340° C.

[1537] FIGS. 228A-D depict assessed hydrocarbon isomer shifts in fluids produced from the experimental cells as a function of temperature and bitumen conversion. Bitumen conversion and temperature increase from left to right in the plots in FIGS. 228A-D with the minimum bitumen conversion being 10%, the maximum bitumen conversion being 100%, the minimum temperature being 277° C., and the maximum temperature being 350° C. The arrows in FIGS. 228A-D show the direction of increasing bitumen conversion and temperature.

[1538] FIG. 228A depicts the hydrocarbon isomer shift of n-butane- $\delta^{13}C_4$ percentage (y-axis) versus propane- $\delta^{13}C_3$ percentage (x-axis). FIG. 228B depicts the hydrocarbon isomer shift of n-pentane- $\delta^{13}C_5$ percentage (y-axis) versus propane- $\delta^{13}C_3$ percentage (x-axis). FIG. 228C depicts the hydrocarbon isomer shift of n-pentane- $\delta^{13}C_5$ percentage (y-axis) versus n-butane- $\delta^{13}C_4$ percentage (x-axis). FIG. 228D depicts the hydrocarbon isomer shift of i-pentane- $\delta^{13}C_5$ percentage (y-axis) versus i-butane- $\delta^{13}C_4$ percentage (x-axis). FIGS. 228A-D show that there is a relatively linear relationship between the hydrocarbon isomer shifts and both temperature and bitumen conversion. The relatively linear relationship may be used to assess formation temperature and/or bitumen conversion by monitoring the hydrocarbon isomer shifts in fluids produced from the formation.

[1539] FIG. 229 depicts weight percentage (Wt %) (y-axis) of saturates from SARA analysis of the produced fluids versus temperature (° C.) (x-axis). The logarithmic relationship between the weight percentage of saturates and temperature may be used to assess formation temperature by monitoring the weight percentage of saturates in fluids produced from the formation.

[1540] FIG. 230 depicts weight percentage (Wt %) (y-axis) of n-C₇ of the produced fluids versus temperature (° C.) (x-axis). The linear relationship between the weight percentage of n-C₇ and temperature may be used to assess formation

temperature by monitoring the weight percentage of n-C₇ in fluids produced from the formation.

Pre-Heating Using Heaters For Infectivity Before Steam Drive Example

[1541] An example uses the embodiment depicted in FIGS. 103 and 104 to preheat. Injection wells 602 and production wells 206 are substantially vertical wells. Heaters 412 are long substantially horizontal heaters positioned so that the heaters pass in the vicinity of injection wells 602. Heaters 412 intersect the vertical well patterns slightly displaced from the vertical wells.

[1542] The following conditions were assumed for purposes of this example:

- (a) heater well spacing; s=330 ft;
- (b) formation thickness; h=100 ft;
- (c) formation heat capacity; ρc=35 BTU/cu. ft.-° F.
- (d) formation thermal conductivity; λ=1.2 BTU/ft-hr-° F.;
- (e) electric heating rate; q_h=200 watts/ft;
- (f) steam injection rate; q_s=500 bbls/day;
- (g) enthalpy of steam; h_s=1000 BTU/lb;
- (h) time of heating; t=1 year;
- (i) total electric heat injection; Q_E=BTU/pattern/year;
- (j) radius of electric heat; r=ft; and
- (k) total steam heat injected; Q_s=BTU/pattern/year.

[1543] Electric heating for one well pattern for one year is given by:

$$Q_E = q_h t s \text{ (BTU/pattern/year);} \tag{EQN. 13}$$

with Q_E=(200 watts/ft)[0.001 kw/watt](1 yr)[365 day/yr][24 hr/day][3413 BTU/kw-hr](330 ft)=1.9733×10⁹ BTU/pattern/year.

[1544] Steam heating for one well pattern for one year is given by:

$$Q_s = q_s t h_s \text{ (BTU/pattern/year);} \tag{EQN. 14}$$

with Q_s=(500 bbls/day)(1 yr) [365 day/yr][1000 BTU/lb][350 lbs/bbl]=63.875×10⁹ BTU/pattern/year.

[1545] Thus, electric heat divided by total heat is given by:

$$Q_E / (Q_E + Q_s) \times 100 = 3\% \text{ of the total heat.} \tag{EQN. 15}$$

[1546] Thus, the electrical energy is only a small fraction of the total heat injected into the formation.

[1547] The actual temperature of the region around a heater is described by an exponential integral function. The integrated form of the exponential integral function shows that about half the energy injected is nearly equal to about half of the injection well temperature. The temperature required to reduce viscosity of the heavy oil is assumed to be 500° F. The volume heated to 500° F. by an electric heater in one year is given by:

$$V_E = \pi r^2. \tag{EQN. 16}$$

[1548] The heat balance is given by:

$$Q_E = (\pi r^2) (s) (\rho c) (\Delta T). \tag{EQN. 17}$$

Thus, r_E can be solved for and is found to be 10.4 ft. For an electric heater operated at 1000° F., the diameter of a cylinder heated to half that temperature for one year would be about 23 ft. Depending on the permeability profile in the injection wells, additional horizontal wells may be stacked above the one at the bottom of the formation and/or periods of electric heating may be extended. For a ten year heating period, the diameter of the region heated above 500° F. would be about 60 ft.

[1549] If all the steam were injected uniformly into the steam injectors over the 100 ft. interval for a period of one year, the equivalent volume of formation that could be heated to 500° F. would be give by:

$$Q_s = (\pi r_s^2) (s) (\rho c) (\Delta T). \tag{EQN. 18}$$

[1550] Solving for r_s gives an r_s of 107 ft. This amount of heat would be sufficient to heat about ¾ of the pattern to 500° F.

Tar Sands Oil Recovery Example

[1551] A STARS simulation was used in combination with experimental analysis to simulate an in situ heat treatment process of a tar sands formation. The experiments and simulations were used to determine oil recovery (measured by volume percentage (vol %) of oil in place (bitumen in place)) versus API gravity of the produced fluid as affected by pressure in the formation. The experiments and simulations also were used to determine recovery efficiency (percentage of oil (bitumen) recovered) versus temperature at different pressures.

[1552] FIG. 231 depicts oil recovery (volume percentage bitumen in place (vol % BIP)) versus API gravity (°) as determined by the pressure (MPa) in the formation. As shown in FIG. 231, oil recovery decreases with increasing API gravity and increasing pressure up to a certain pressure (about 2.9 MPa in this experiment). Above that pressure, oil recovery and API gravity decrease with increasing pressure (up to about 10 MPa in the experiment). Thus, it may be advantageous to control the pressure in the formation below a selected value to get higher oil recovery along with a desired API gravity in the produced fluid.

[1553] FIG. 232 depicts recovery efficiency (%) versus temperature (° C.) at different pressures. Curve 1110 depicts recovery efficiency versus temperature at 0 MPa. Curve 1112 depicts recovery efficiency versus temperature at 0.7 MPa. Curve 1114 depicts recovery efficiency versus temperature at 5 MPa. Curve 1116 depicts recovery efficiency versus temperature at 10 MPa. As shown by these curves, increasing the pressure reduces the recovery efficiency in the formation at pyrolysis temperatures (temperatures above about 300° C. in the experiment). The effect of pressure may be reduced by reducing the pressure in the formation at higher temperatures, as shown by curve 1118. Curve 1118 depicts recovery efficiency versus temperature with the pressure being 5 MPa up until about 380° C., when the pressure is reduced to 0.7 MPa. As shown by curve 1118, the recovery efficiency can be increased by reducing the pressure even at higher temperatures. The effect of higher pressures on the recovery efficiency is reduced when the pressure is reduced before hydrocarbons (oil) in the formation have been converted to coke.

Molten Salt Circulation System Simulation

[1554] A simulation was run using molten salt in a circulation system to heat an oil shale formation. The well spacing was 30 ft, and the treatment area was 5000 ft of formation surrounding a substantially horizontal portion of the piping. The overburden had a thickness of 984 ft. The piping in the formation includes an inner conduit positioned in an outer conduit. Adjacent to the treatment area, the outer conduit is a 4" schedule 80 pipe, and the molten salt flows through the annular region between the outer conduit and the inner conduit. Through the overburden of the formation, the molten salt flows through the inner conduit. A first fluid switcher in the

piping changes the flow from the inner conduit to the annular region before the treatment area, and a second fluid switcher in the piping changes the flow from the annular region to the inner conduit after the treatment area.

[1555] FIG. 233 depicts time to reach a target reservoir temperature of 340° C. for different mass flow rates or different inlet temperatures. Curve 1120 depicts the case for an inlet molten salt temperature of 550° C. and a mass flow rate of 6 kg/s. The time to reach the target temperature was 1405 days. Curve 1122 depicts the case for an inlet molten salt temperature of 550° C. and a mass flow rate of 12 kg/s. The time to reach the target temperature was 1185 days. Curve 1124 depicts the case for an inlet molten salt temperature of 700° C. and a mass flow rate of 12 kg/s. The time to reach the target temperature was 745 days.

[1556] FIG. 234 depicts molten salt temperature at the end of the treatment area and power injection rate versus time for the cases where the inlet molten salt temperature was 550° C. Curve 1126 depicts molten salt temperature at the end of the treatment area for the case when the mass flow rate was 6 kg/s. Curve 1128 depicts molten salt temperature at the end of the treatment area for the case when the mass flow rate was 12 kg/s. Curve 1130 depicts power injection rate into the formation (W/ft) for the case when the mass flow rate was 6 kg/s. Curve 1132 depicts power injection rate into the formation (W/ft) for the case when the mass flow rate was 12 kg/s. The circled data points indicate when heating was stopped.

[1557] FIG. 235 and FIG. 236 depicts simulation results for 8000 ft heating portions of heaters positioned in the Grosmont formation of Canada for two different mass flow rates. FIG. 235 depicts results for a mass flow rate of 18 kg/s. Curve 1134 depicts heater inlet temperature of about 540° C. Curve 1136 depicts heater outlet temperature. Curve 1138 depicts heated volume average temperature. Curve 1140 depicts power injection rate into the formation. FIG. 236 depicts results for a mass flow rate of 12 kg/s. Curve 1142 depicts heater inlet temperature of about 540° C. Curve 1144 depicts heater outlet temperature. Curve 1146 depicts heated volume average temperature. Curve 1148 depicts power injection rate into the formation.

[1558] This examples demonstrates a method of using a system that includes at least one fluid circulation system configured to provide hot heat transfer fluid to a plurality of heaters in the formation, and a plurality of heaters in the formation coupled to the circulation system. At least one of the heaters includes a first conduit, a second conduit positioned in the first conduit, and a first flow switcher. The flow switcher is configured to allow a fluid flowing through the second conduit to flow through the annular region between the first conduit and the second conduit.

Power Requirement Simulation

[1559] A simulation to determine the power requirements to heat a formation with a molten salt was performed. Molten salt was circulated through wellbores in a hydrocarbon containing formation and the power requirements to heat the formation using molten salt were assessed over time. The distance between the wellbores was varied to determine the effect upon the power requirements.

[1560] FIG. 237 depicts curve 1150 of power (W/ft)(y-axis) versus time (yr)(x-axis) of in situ heat treatment power injection requirements. FIG. 238 depicts power (W/ft)(y-axis) versus time (days)(x-axis) of in situ heat treatment power injection requirements for different spacings between

wellbores. Curves 1152-1160 depict the results in FIG. 238. Curve 1152 depicts power required versus time for heater wellbores with a spacing of about 14.4 meters. Curve 1154 depicts power required versus time for heater wellbores with a spacing of about 13.2 meters. Curve 1156 depicts power required versus time for the Grosmont formation in Alberta, Canada, with heater wellbores laid out in a hexagonal pattern and with a spacing of about 12 meters. Curve 1158 depicts power required versus time for heater wellbores with a spacing of about 9.6 meters. Curve 1160 depicts power required versus time for heater wellbores with a spacing of about 7.2 meters.

[1561] From the graph in FIG. 238, wellbore spacing represented by curve 1158 is the spacing which approximately correlates to the power output over time of certain nuclear reactors (for example, at least some nuclear reactors having a power output that decays at a rate of about 1/E, for example, in about 4 to 9 years). Curves 1152-1156, in FIG. 238, depict the required power output for heater wellbores with spacing ranging from about 12 meters to about 14.4 meters. Spacing between heater wellbores greater than about 12 meters may require more power input than certain nuclear reactors may be able to provide. Spacing between heater wellbores less than about 8 meters (for example, as represented by curve 1160 in FIG. 238) may not make efficient use of the power input provided by certain nuclear reactors.

[1562] FIG. 239 depicts reservoir average temperature (° C.)(y-axis) versus time (days)(x-axis) of in situ heat treatment for different spacings between wellbores. Curves 1152-1160 depict the temperature increase in the formation over time based upon the power input requirements for the well spacing. A target temperature for in situ heat treatment of hydrocarbon containing formations, in some embodiments, for example may be about 350° C. The target temperature for a formation may vary depending on, at least, the type of formation and/or the desired hydrocarbon products. The spacing between the wellbores for curves 1152-1160 in FIG. 239 are the same for curves 1152-1160 in FIG. 238. Curves 1152-1156, in FIG. 239, depict the increasing temperature in the formation over time for heater wellbores with spacing ranging from about 12 meters to about 14.4 meters. Spacing between heater wellbores greater than about 12 meters may heat the formation too slowly such that more energy may be required than certain nuclear reactors may be able to provide (especially after about 5 years in the current example). Spacing between heater wellbores less than about 8 meters (for example, as represented by curve 1160 in FIG. 239) may heat the formation too quickly for some in situ heat treatment situations. From the graph in FIG. 239, wellbore spacing represented by curve 1158 may be the spacing that achieves a typical target temperature of about 350° C. in a desirable time frame (for example, about 5 years).

Aqueous Molten Salt Simulation

[1563] A simulation was run to simulate forming a heat transfer fluid in a circulation system to heat a subsurface formation. The well spacing was 50 ft and the treatment area was 2000 ft of formation surrounding a substantially horizontal portion of the piping. The overburden had a thickness of 1400 ft. The heater in the formation was L-shaped and included an inlet conduit and an outlet conduit. Adjacent to the treatment area, the outlet conduit was a 6" schedule 80 pipe, and included two insulated pipes that formed a channel (inlet conduit) inside the pipe. The heat transfer fluid flowed

down the inlet conduit and back up through the annulus (outlet conduit) between the outside of the two inner pipes and the inner walls of the 6" pipe. Initially, water was circulated at ambient temperatures through the circulation system. While circulating, the temperature of the water was raised to about 100° C. Solar salt was added to the circulating system over a period of 48 hours to form an aqueous molten salt mixture. The temperature of the solution was raised over time to evaporate the water from the salt solution to form the molten salt.

[1564] FIG. 240 depicts time (hour) versus temperature (° C.) and molten salt concentration in weight percent. Curve 1162 depicts salt concentration over time. Curve 1164 depicts temperatures at the inlet of the inlet conduit over time. Curve 1166 depicts the temperature at the outlet of the outlet conduit over time. Curve 1168 depicts the aqueous molten salt mixture temperature over time. Data point 1170 depicts the start of the addition of the salt into water circulating through the piping. Data point 1172 depicts the temperature at which water starts to evaporate. The shaded area between curves 1164 and 1166 depicts the amount of energy delivered to the section of the formation to be heated. The shaded area between curves 1166 and 1168 depicts the amount of energy used for evaporation of water from the aqueous molten salt mixture. FIG. 241 depicts heat transfer rates versus time. Curve 1174 depicts rate of heat transfer to the portion of the formation to be heated over time. Curve 1176 depicts rate of heat loss to the overburden over time.

[1565] This example demonstrates a method of heating a subsurface formation that includes circulating a first heat transfer fluid through piping positioned in a wellbore; heating at least a portion of the first heat transfer fluid; and adding one or more salts to the heated portion of the first heat transfer fluid to form a heated salt solution. The salt solution contains the first heat transfer fluid and the one or more salts. At least a portion of a formation is heated to a first temperature with the heated salt solution. At least a portion of the first heat transfer fluid is removed to form a second heat transfer fluid. The portion of the formation is heated to a second temperature with the second heat transfer fluid with the second temperature being higher than the first temperature.

ISHT Residue/Asphalt/Bitumen Composition Example

[1566] In situ heat treatment (ISHT) residue (8.2 grams) having the properties listed in TABLE 8 was added to asphalt/bitumen (91.8 grams, pen grade 160/220, Petit Couronne refinery) at 190° C. and stirred for 20 min under low shear to form a ISHT residue/asphalt/bitumen mixture. The ISHT residue/asphalt/bitumen mixture was equivalent to a 70/100 pen grade (paving grade) asphalt/bitumen. The properties of the ISHT residue/asphalt/bitumen blend are listed in TABLE 9.

TABLE 8

Properties	Value
<u>Distillation, ° C. SIMDIS 750</u>	
Initial boiling point	407
Final boiling point	>750

TABLE 8-continued

Properties	Value
<u>Saturates, Aromatics, Resins and Asphaltenes, wt % modified GSEE method (roofing felt manufacturers group)</u>	
Saturates	2.4
Aromatics	10.3
Resins	35.8
Asphaltenes	51.6
Sulfur, wt %, ASTM Test Method, D2622,	1.6
Total Nitrogen, wt %, ASTM Test Method D5762	2.4
<u>Metals, ppm ICP, ASTM Test Method D5185</u>	
Aluminum	2
Calcium	5
Iron	100
Potassium	9
Magnesium	<1
Sodium	10
Nickel	50
Vanadium	5
Pen @60° C., 0.1 mm EN 1426	3
R&B Temperature, ° C. EN 1427	139
Relative density at 25° C., densitometer	1.094

TABLE 9

Properties	ISHT Residue Blend	Spec. (EN12591)
<u>Properties of fresh blend</u>		
Pen, 25° C., 0.1 mm	85	70-100
Softening Point, ° C.	45.4	43-51
Flash point, ° C.	>310	>230
Fraass breaking point, ° C.	-26	-10
<u>Dynamic Viscosity, Pa · s</u>		
at 100° C.	2.3179	
at 135° C.	0.3112	
at 150° C.	0.1569	
at 170° C.	0.0711	
<u>Properties after RTFOT ageing (EN12607-1)</u>		
Softening point, ° C.	51.6	>45
Mass change, %	+0.13	<0.8
Retained pen, %	60.0	>46
Delta softening point, ° C.	6.2	<9

[1567] The water absorption of a concrete mixture having the components listed in TABLE 10 was determined as a function of time during immersion at a water temperature of 60° C. Stiffness was characterized via the indirect tensile stiffness modulus (ISTM) as detailed below.

TABLE 10

Component	Mass (g)	wt %
Filler Wigro	79.8	6.7%
Drain sand	34.9	2.9%
Westerschelde sand	68.6	5.8%
Crushed sand	310.3	26.1%
2/6 Dutch Crushed Gravel	172	14.5%
4/8 Dutch Crushed Gravel	229.4	19.3%
8/11 Dutch Crushed Gravel	229.4	19.3%
ISHT residue/Bitumen blend	65.2	5.5%
Total	1189.6	100%

[1568] Asphalt Concrete Mixture.

[1569] Specimen preparation. The components in TABLE 10 were mixed at a 150° C. and compacted at a temperature of 140° C. to form cylinders having a diameter of 100 mm and a thickness of 63 mm thickness (Marshall specimens). The specimens were dried and the bulk density and voids in mixture (VIM) were determined on each specimen according to EN12697-6 and EN12697-8 respectively.

[1570] Conditioning of the specimens. Specimens were first immersed in a water bath at 4° C. and vacuum was applied for a 30 minutes period in order to decrease pressure from atmospheric pressure to 2.4 kPa (24 mbar). The pressure was maintained at 2.4 kPa for 2.5 hours. The specimens were immersed in water at a temperature of 60° C. for several days and then dried at room temperature.

[1571] Water adsorption was determined after vacuum treatment and after water conditioning of the specimens at 60° C. The conditioned specimens were placed in 20° C. water for 1 hour. The specimens were removed and the amount of water absorbed was compared with the voids content of the specimen. This ratio is presented as the degree of water saturation (volume ratio in percent).

[1572] Indirect Tensile Stiffness Modulus test was performed according to EN 12697-26 annex C. The ITSM test was carried out in the Nottingham Asphalt Tester using a rise time of 124 ms, 5 µm horizontal deformation and a temperature of 20° C. The ITSM values of the dry specimens were determined after 3 hours conditioning at 20° C. in air. After water conditioning, the ITSM test at 20° C. was carried out rapidly after the weighting of the specimen, to avoid the loss of water. The ITSM test was also carried out during the drying period for the specimens. The results are expressed as percentage of the dry, initial ITSM value.

[1573] FIG. 242 depicts percentage of degree of saturation (volume water/air voids) versus time during immersion at a water temperature of 60° C. FIG. 243 depicts retained indirect tensile strength stiffness modulus versus time during immersion at a water temperature of 60° C. In FIGS. 242 and 243, plots 1178 and 1190 are 70/100 pen grade asphalt/bitumen without any adhesion improvers, plots 1180 and 1192 are a 70/100 pen grade asphalt/bitumen with 0.5% by weight acidic type adhesion improver, plots 1182 and 1194 are a 70/100 pen grade asphalt/bitumen with 1% by weight acidic type adhesion improver, plots 1184 and 1196 are a 70/100 pen grade asphalt/bitumen with 0.5% by weight amine type adhesion improver, plots 1186 and 1198 are a 70/100 pen grade asphalt/bitumen with 1% by weight amine type adhesion improver, and plots 1188 are 1200 are a ISHT/asphalt/bitumen composition. In FIG. 242, the initial rise in water absorption was due to vacuum treatment of the samples to induce water into the asphalt/bitumen compositions. After 10 days of treatment, the ISHT/asphalt/bitumen composition (plot 1188) had similar water adsorption characteristics as the asphalt/bitumen blends containing amines and/or acidic-type adhesion improvers. In FIG. 243, ISHT/asphalt/bitumen composition (plot 1188) had similar or better retained tensile strength stiffness modulus than asphalt/bitumen blends containing amines and/or acidic-type adhesion improvers.

[1574] As shown in Tables 8 and 9 and FIGS. 242 and 243, an ISHT/asphalt/bitumen composition has properties suitable for use as a binder for paving, enhanced water shedding properties, and enhanced tensile strength characteristics.

[1575] In this patent, certain U.S. patents, U.S. patent applications, and other materials (for example, articles) have been

incorporated by reference. The text of such U.S. patents, U.S. patent applications, and other materials is, however, only incorporated by reference to the extent that no conflict exists between such text and the other statements and drawings set forth herein. In the event of such conflict, then any such conflicting text in such incorporated by reference U.S. patents, U.S. patent applications, and other materials is specifically not incorporated by reference in this patent.

[1576] Further modifications and alternative embodiments of various aspects of the invention may be apparent to those skilled in the art in view of this description. Accordingly, this description is to be construed as illustrative only and is for the purpose of teaching those skilled in the art the general manner of carrying out the invention. It is to be understood that the forms of the invention shown and described herein are to be taken as the presently preferred embodiments. Elements and materials may be substituted for those illustrated and described herein, parts and processes may be reversed, and certain features of the invention may be utilized independently, all as would be apparent to one skilled in the art after having the benefit of this description of the invention. Changes may be made in the elements described herein without departing from the spirit and scope of the invention as described in the following claims. In addition, it is to be understood that features described herein independently may, in certain embodiments, be combined.

1-827. (canceled)

828. An in situ heat treatment system for producing hydrocarbons from a subsurface formation, comprising:

a plurality of wellbores in the formation;

at least one heater positioned in at least two of the wellbores; and

a self-regulating nuclear reactor configured to provide energy to at least one of the heaters to increase the temperature of at least a portion of the formation to temperatures that allow for hydrocarbon production from the formation;

wherein heat input to at least a portion of the formation over time at least approximately correlates to a rate of decay of the power from the self-regulating nuclear reactor.

829. The system of claim 828, wherein a spacing between at least a portion of the plurality of wellbores in the formation is at least partially correlated to the rate of decay of the power from the self-regulating nuclear reactor.

830. The system of claim 828, wherein the self-regulating nuclear reactor comprises a core, wherein the core comprises a powdered fissile metal hydride material.

831. The system of claim 828, wherein the power from the self-regulating nuclear reactor decays to about 1/E of an initial power of the self-regulating nuclear reactor in about 4 to 9 years.

832. The system of claim 828, wherein the self-regulating nuclear reactor initially provides to at least a portion of the wellbores a power output of about 300 watts/foot that decreases over time to about 120 watts/foot.

833. The system of claim 828, wherein the self-regulating nuclear reactor initially provides to at least a portion of the wellbores a power output of about 300 watts/foot that decreases over a predetermined time period to about 120 watts/foot.

834. The system of claim 828, wherein the self-regulating nuclear reactor initially provides to at least a portion of the wellbores a power output of about 300 watts/foot that decreases over a predetermined time period to about 120

watts/foot, wherein the predetermined time period ranges from about 4 to about 8 years.

835. The system of claim **828**, wherein the self-regulating nuclear reactor initially provides to at least a portion of the wellbores a power output of about 300 watts/foot that decreases over a predetermined time period to about 120 watts/foot, wherein the predetermined time period ranges from about 5 to about 7 years.

836. The system of claim **828**, wherein the self-regulating nuclear reactor is configured to provide energy to at least one of the heaters to increase the temperature of at least a portion of the formation to within a range of about 300° C. to about 400° C.

837. The system of claim **828**, wherein the self-regulating nuclear reactor is configured to provide energy to at least one of the heaters to increase the temperature of at least a portion of the formation to within a range of about 300° C. to about 400° C. within a predetermined time period, wherein the predetermined time period ranges from about 4 to about 8 years.

838. The system of claim **828**, wherein the self-regulating nuclear reactor is configured to provide energy to at least one of the heaters to increase the temperature of at least a portion of the formation to within a range of about 300° C. to about 400° C. within a predetermined time period, wherein the predetermined time period ranges from about 5 to about 7 years.

839. The system of claim **828**, wherein the spacing between at least a portion of the plurality of wellbores in the formation ranges between about 8 meters to about 11 meters.

840. The system of claim **828**, wherein the spacing between at least a portion of the plurality of wellbores in the formation ranges between about 9 meters to about 10 meters.

841. The system of claim **828**, wherein the spacing between at least a portion of the plurality of wellbores in the formation ranges between about 9.4 meters to about 9.8 meters.

842. The system of claim **828**, wherein the self-regulating nuclear reactor is configured to provide thermal energy to at least one of the heaters using a heat transfer fluid.

843. The system of claim **828**, wherein the self-regulating nuclear reactor is configured to provide thermal energy to at least one of the heaters using a heat transfer fluid, and wherein the heat transfer fluid comprises a molten salt.

844. A method of producing hydrocarbons from a subsurface formation, comprising:

providing energy to at least one heater to heat the temperature of the formation to temperatures that allow for hydrocarbon production from the formation using a self-regulating nuclear reactor, wherein the at least one heater is located in at least one of a plurality of heater

wellbores located in the formation, and wherein at least one heater is located in at least one of the other heater wellbores; and

at least approximately correlating heat input to at least a portion of the formation over time to a rate of decay of the power from the self-regulating nuclear reactor.

845. The method of claim **844**, further comprising at least partially correlating a spacing between at least a portion of the plurality of wellbores in the formation to a the rate of decay of the power from the self-regulating nuclear reactor.

846. The method of claim **844**, wherein the self-regulating nuclear reactor comprises a core, and wherein the core comprises a powdered fissile metal hydride material.

847. The method of claim **844**, wherein the power from the self-regulating nuclear reactor decays to about 1/E of an initial power of the self-regulating nuclear reactor in about 4 to 9 years.

848. The method of claim **844**, further comprising providing an initial power output using the self-regulating nuclear reactor of about 300 watts/foot that decreases over a predetermined time period to about 120 watts/foot to at least a portion of the wellbores.

849. The method of claim **844**, further comprising providing an initial power output using the self-regulating nuclear reactor of about 300 watts/foot that decreases over a predetermined time period to about 120 watts/foot to at least a portion of the wellbores, wherein the predetermined time period ranges from about 4 to about 8 years.

850. The method of claim **844**, further comprising providing energy to at least one of the heaters using the self-regulating nuclear reactor to increase the temperature of at least a portion of the formation to within a range of about 300° C. to about 400° C.

851. The method of claim **844**, further comprising providing energy to at least one of the heaters using the self-regulating nuclear reactor to increase the temperature of at least a portion of the formation to within a range of about 300° C. to about 400° C. within a predetermined time period, wherein the predetermined time period ranges from about 4 to about 8 years.

852. The method of claim **844**, wherein the spacing between at least a portion of the plurality of wellbores in the formation ranges between about 8 meters to about 11 meters.

853. The method of claim **844**, further comprising providing thermal energy to at least one of the heaters using a heat transfer fluid heated with the self-regulating nuclear reactor.

854. The method of claim **844**, further comprising providing thermal energy to at least one of the heaters using a heat transfer fluid heated with the self-regulating nuclear reactor, wherein the heat transfer fluid comprises a molten salt.

855-1180. (canceled)

* * * * *