

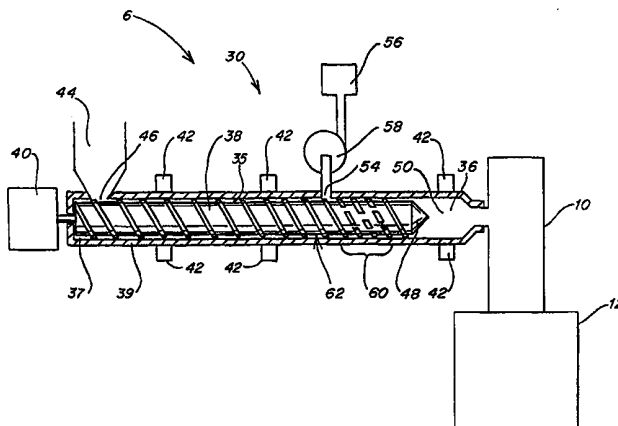

## INTERNATIONAL APPLICATION PUBLISHED UNDER THE PATENT COOPERATION TREATY (PCT)-

<p>(51) International Patent Classification <sup>6</sup> : C08J 9/00, B65D 1/02</p>	<p>A1</p>	<p>(11) International Publication Number: <b>WO 99/32544</b></p> <p>(43) International Publication Date: 1 July 1999 (01.07.99)</p>
<p>(21) International Application Number: PCT/US98/27118</p> <p>(22) International Filing Date: 18 December 1998 (18.12.98)</p> <p>(30) Priority Data: 60/068,173 19 December 1997 (19.12.97) US 60/107,754 10 November 1998 (10.11.98) US</p> <p>(71) Applicant (for all designated States except US): TREXEL, INC. [US/US]; 45 Sixth Road, Woburn, MA 01801 (US).</p> <p>(72) Inventors; and (75) Inventors/Applicants (for US only): ANDERSON, Jere, R. [US/US]; 15 Boylston Street, Newburyport, MA 01950 (US). STRAFF, Richard, S. [US/US]; 2 Sheldon Road, Marblehead, MA 01945 (US). OKAMOTO, Kelvin [US/US]; 717 Atlantic Avenue #3A, Boston, MA 02111 (US). BLIZARD, Kent [US/US]; 221 Eliot Street, Ashland, MA 02116 (US). PIERICK, David [US/US]; 23 Sawmill Way, Georgetown, MA 01833 (US).</p> <p>(74) Agent: OYER, Timothy, J.; Wolf, Greenfield &amp; Sacks, P.C., 600 Atlantic Avenue, Boston, MA 02210 (US).</p>	<p>(81) Designated States: AU, CA, CN, JP, US, European patent (AT, BE, CH, CY, DE, DK, ES, FI, FR, GB, GR, IE, IT, LU, MC, NL, PT, SE).</p> <p><b>Published</b> <i>With international search report. Before the expiration of the time limit for amending the claims and to be republished in the event of the receipt of amendments.</i></p>	

(54) Title: MICROCELLULAR FOAM EXTRUSION/BLOW MOLDING PROCESS AND ARTICLE MADE THEREBY



## (57) Abstract

A microcellular injection blow molding system and method, and microcellular blow molded articles produced thereby, are described. The system is equipped to extrude microcellular material that changes in thickness, material density, or both in the machine direction while maintaining a constant pressure drop rate during nucleation just prior to extrusion, providing the ability to produce consistent uniform microcellular material independent of material thickness. The systems and methods are particularly useful in production of strong, thin-walled, non-liquid-permeable, opaque containers that do not contain reinforcing agent, chromophore, or residue of chemical blowing agent or chemical blowing agent by-product. Semi-crystalline microcellular foams that include a midlevel amount of nucleating agent, and methods of their production, also are provided. The microcellular foams can be produced in typical polymer processing techniques such as extrusion, injection molding and blow molding. The foams exhibit excellent mechanical properties and can be formed over a broad range of density into a number of different foam articles. Also provided are high-density polyethylene foams and dies that are suited for use with HDPE, foams.

**FOR THE PURPOSES OF INFORMATION ONLY**

Codes used to identify States party to the PCT on the front pages of pamphlets publishing international applications under the PCT.

<b>AL</b>	Albania	<b>ES</b>	Spain	<b>LS</b>	Lesotho	<b>SI</b>	Slovenia
<b>AM</b>	Armenia	<b>FI</b>	Finland	<b>LT</b>	Lithuania	<b>SK</b>	Slovakia
<b>AT</b>	Austria	<b>FR</b>	France	<b>LU</b>	Luxembourg	<b>SN</b>	Senegal
<b>AU</b>	Australia	<b>GA</b>	Gabon	<b>LV</b>	Latvia	<b>SZ</b>	Swaziland
<b>AZ</b>	Azerbaijan	<b>GB</b>	United Kingdom	<b>MC</b>	Monaco	<b>TD</b>	Chad
<b>BA</b>	Bosnia and Herzegovina	<b>GE</b>	Georgia	<b>MD</b>	Republic of Moldova	<b>TG</b>	Togo
<b>BB</b>	Barbados	<b>GH</b>	Ghana	<b>MG</b>	Madagascar	<b>TJ</b>	Tajikistan
<b>BE</b>	Belgium	<b>GN</b>	Guinea	<b>MK</b>	The former Yugoslav Republic of Macedonia	<b>TM</b>	Turkmenistan
<b>BF</b>	Burkina Faso	<b>GR</b>	Greece	<b>ML</b>	Mali	<b>TR</b>	Turkey
<b>BG</b>	Bulgaria	<b>HU</b>	Hungary	<b>MN</b>	Mongolia	<b>TT</b>	Trinidad and Tobago
<b>BJ</b>	Benin	<b>IE</b>	Ireland	<b>MR</b>	Mauritania	<b>UA</b>	Ukraine
<b>BR</b>	Brazil	<b>IL</b>	Israel	<b>MW</b>	Malawi	<b>UG</b>	Uganda
<b>BY</b>	Belarus	<b>IS</b>	Iceland	<b>MX</b>	Mexico	<b>US</b>	United States of America
<b>CA</b>	Canada	<b>IT</b>	Italy	<b>NE</b>	Niger	<b>UZ</b>	Uzbekistan
<b>CF</b>	Central African Republic	<b>JP</b>	Japan	<b>NL</b>	Netherlands	<b>VN</b>	Viet Nam
<b>CG</b>	Congo	<b>KE</b>	Kenya	<b>NO</b>	Norway	<b>YU</b>	Yugoslavia
<b>CH</b>	Switzerland	<b>KG</b>	Kyrgyzstan	<b>NZ</b>	New Zealand	<b>ZW</b>	Zimbabwe
<b>CI</b>	Côte d'Ivoire	<b>KP</b>	Democratic People's Republic of Korea	<b>PL</b>	Poland		
<b>CM</b>	Cameroon		Republic of Korea	<b>PT</b>	Portugal		
<b>CN</b>	China	<b>KZ</b>	Republic of Korea	<b>RO</b>	Romania		
<b>CU</b>	Cuba	<b>LC</b>	Kazakstan	<b>RU</b>	Russian Federation		
<b>CZ</b>	Czech Republic	<b>LI</b>	Saint Lucia	<b>SD</b>	Sudan		
<b>DE</b>	Germany	<b>LK</b>	Liechtenstein	<b>SE</b>	Sweden		
<b>DK</b>	Denmark	<b>LR</b>	Sri Lanka	<b>SG</b>	Singapore		
<b>EE</b>	Estonia		Liberia				

## MICROCELLULAR FOAM EXTRUSION/BLOW MOLDING PROCESS AND ARTICLE MADE THEREBY

Related Applications

5 This application is a continuation-in-part of co-pending U.S. application serial no. 60/068,173, filed December 19, 1997 and U.S. application serial no. 60/107,754, filed November 10, 1998, both entitled "Microcellular Extrusion/Blow Molding Process and Article Made Thereby" both by Jere R. Anderson et al., and both incorporated herein by reference.

10

Background of the Invention

Polymeric foams include a plurality of voids, also called cells, in a polymer matrix. By replacing solid plastic with voids, polymeric foams use less raw material than solid plastics for a given volume. Thus, by using polymeric foams in many applications instead of solid plastics, material costs are reduced.

15 Microcellular foams have smaller cell sizes and higher cell densities than conventional polymeric foams. Typically, microcellular foams are defined as having average cell sizes of less than 100 microns and a cell density of greater than  $10^6$  cells/cm<sup>3</sup> of solid plastic. In a typical continuous process for forming microcellular foam (e.g. extrusion), the pressure on a single-phase solution of blowing agent and polymer is rapidly dropped to nucleate the cells. The nucleation rate must be high enough to form the microcellular structure.

Several patents describe aspects of microcellular materials and microcellular processes.

25 U.S. Patent No. 4,473,665 (Martini-Vvedensky, et al.; September 25, 1984) describes a process for making foamed polymer having cells less than about 100 microns in diameter. In the technique of Martini-Vvedensky, et al., a material precursor is saturated with a blowing agent, the material is placed under high pressure, and the pressure is rapidly dropped to nucleate the blowing agent and to allow the formation of cells. The material then is frozen rapidly to maintain a desired distribution of microcells.

30 U.S. Patent No. 5,158,986 (Cha, et al.; October 27, 1992) describes formation of microcellular polymeric material using a supercritical fluid as a blowing agent. In a batch process of Cha, et al., a plastic article is submerged at pressure in supercritical fluid for a

period of time, and then quickly returned to ambient conditions creating a solubility change and nucleation. In a continuous process, a polymeric sheet is extruded, and then can be run through rollers in a container of supercritical fluid at high pressure, and then exposed quickly to ambient conditions. In another continuous process, a supercritical fluid-saturated molten  
5 polymeric stream is established. The polymeric stream is rapidly heated, and the resulting thermodynamic instability (solubility change) creates sites of nucleation, while the system is maintained under pressure preventing significant growth of cells. The material then is injected into a mold cavity where pressure is reduced and cells are allowed to grow.

International patent publication no. WO 98/08667 (Burnham et al.) provides methods  
10 and systems for producing microcellular material, and microcellular articles. In one method of Burnham et al., a fluid, single phase solution of a precursor of foamed polymeric material and a blowing agent is continuously nucleated by dividing the stream into separate portions and separately nucleating each of the separate portions. The divided streams can be recombined into a single stream of nucleated, fluid polymeric material. The recombined  
15 stream may be shaped into a desired form, for example, by a shaping die. Burnham et al. also describe a die for making advantageously thick microcellular articles, that includes a multiple pathway nucleation section. Other methods describe the fabrication of very thin microcellular products, as well. In particular, a method for continuously extruding microcellular material onto a wire, resulting in very thin essentially closed cell microcellular insulating coating  
20 secured to the wire, is provided. In some of the methods, pressure drop rate is an important feature and techniques to control this and other parameters are described.

Polymeric extrusion blow molding is a known process in which a molten polymeric material is extruded from an extruder die as a parison (an essentially cylindrical polymeric sleeve). The parison is placed in a mold and, typically while still warm enough to be soft and  
25 moldable, is subjected to significant gas pressure internal of the cylinder and expanded against the mold. Many common articles such as beverage bottles, motor oil bottles, pharmaceutical packaging, cosmetic packaging, and the like are manufactured using this technique.

In many cases, a parison is extruded so as to have differing thickness along its length. Thicker portions may correspond to locations where the article needs to be reinforced to a  
30 relatively greater extent, or to provide for expansion in some regions to a greater extent than in other regions (in the blow-molding formation of, for example, a plastic detergent bottle), while maintaining an essentially constant thickness in the molded article.

U.S. Patent No. 4,444,702 (Thomas, et al.) describes a system for producing tubular extruded parisons of thermoplastic material, the wall thickness of the extruded parison being varied during extrusion.

U.S. Patent No. 3,939,236 (Hahn) describes a technique involving extruding a cellular  
5 polymeric tubular parison, then blow molding the parison.

U.S. Patent No. 3,225,127 (Scott) describes a process involving extruding molten plastic containing a foaming agent through an annular orifice to form a foamed parison, then placing the parison in a blow mold cavity and expanding the parison within the mold.

U.S. Patent No. 4,874,649 (Daubenbüchel, et al.) states that major difficulties exist in  
10 extrusion blow molding of foam articles in which a preform that has already been foamed is expanded. Daubenbüchel, et al. state that foamed material of a preform that is still in a thermoplastic condition has regions that exhibit different strength and expandability values over the length and periphery of the preform, with the result that weak points are formed under the effect of internal pressure within the preform, and that in many circumstances these  
15 weak points cause the wall of the preform or the molded article produced therefrom to tear open, giving rise to wastage. Daubenbüchel, et al. purportedly solve this problem by co-extruding a multi-layer thermoplastic preform in which at least one layer is non-foamable. Using a non-foamable layer purportedly allows the preform to be expanded, after the material has been foamed, without giving rise to the danger of forming weak points or holes through  
20 the wall of the article. When the layer of non-foamable material is arranged on the outside of the article, an article is produced having a smooth exterior surface. Daubenbüchel, et al. also describe blow-molding expansion of the preforms at a pressure on the order of 1 bar, or less than around 0.5 bar, which they characterize as markedly lower than in the case of conventional extrusion blowing process, to avoid bubbles or pores in the foamed material  
25 from being compressed.

Conventional foam processes, in some cases, incorporate nucleating agents, some of which are inorganic solid particles, into the polymer melt during processing. Such agents can be of a variety of compositions, such as talc and calcium carbonate. In particular, nucleating agents are incorporated into the polymer melt typically at levels less than 1% by weight of  
30 polymeric melt to lower the energy for cell nucleation. The dispersion of nucleating agents within the polymer mixture is often times critical in forming a uniform cell structure. In some cases, higher levels are not used because of the agglomeration of the particles which can lead

to non-uniform cell structures having anomalous large cells. The following U.S. Patents describe the use of nucleating agents in foam processes.

U.S. Patent No. 3,491,032 (Skochdopole et al.; January 20, 1970) describes a process for making cellular polymer materials. In a process of Skochdopole, finally divided solid  
5 materials such as calcium silicate, zinc stearate, magnesium stearate and the like can advantageously be incorporated with the polymer or gel prior to expanding the same. Such finely divided materials aid in controlling the size of the cells, and are employed in amounts of from about 0.01% to about 2.0% by weight of the polymer.

U.S. Patent No. 5,116,881 (Park et al.; May 26, 1992) describes polypropylene foam  
10 sheets and a process for their manufacture. In a process of Park, a nucleating agent is used to create sites for bubble initiation. It is preferred that the nucleating agent have a particle size in the range of 0.3 to 5.0 microns and that its concentration be less than one part per hundred parts polymer by weight. Concentrations of nucleating agents greater than five parts per hundred parts polymer by weight leads to agglomeration, or insufficient dispersion of  
15 nucleating substance so that the diameter of the cell size becomes greater.

Fillers in polymeric foams are typically added in amounts of at least 20% by weight polymeric material, and in many cases greater than 30% by weight. In international patent publication no. WO 98/08667 described above, Burnham describes examples of microcellular material that include filler levels in an amount of at least 10% by weight polymeric material,  
20 other examples include filler levels in an amount of at least about 25% by weight polymeric material, other examples include filler levels in an amount of at least about 35% by weight polymeric material, and still other examples include filler levels of at least about 50% by weight polymeric material.

High-density polyethylene (HDPE) has traditionally been a difficult material to  
25 process as a foam. This, in part, arises from the low melt strength of HDPE. Processes that employ chemical blowing agents have been developed to produce foams from high-density polyethylene. Additionally, HDPE foams have been produced by batch processes (see, for example, U.S. Patent No. 5,158,986. However, the applicants are unaware of extruded or foam-molded foams from HDPE produced without the use of chemical blowing agents or  
30 without the addition of greater than 20% additive like low density polyethylene (LDPE) or linear low density polyethylene (LLDPE).

In addition, in general, extrusion of microcellular material can be technically

complicated because a balance of pressure drop rate, temperature, blowing agent content, and die shape and design can affect properties and appearance of an extruded microcellular article.

While processes for the extrusion blow molding of foamed polymeric material are known, a need exists for simplified processes for production of extruded blow-molded products having good physical qualities. Additionally, though nucleating agents have been used in low weight percentages in the production of foams and fillers have been used in high weight percentages in the production of conventional foams and microcellular foams, foam processes typically have not employed a midlevel amount of nucleating agent. It is an object of the invention, therefore, to provide extrusion blow-molded foam articles of good physical properties, and techniques for producing these articles. It is another object to provide relatively thin-walled extruded, blow-molded foam articles and techniques for producing these articles that involve controlling foam uniformity and density. It is another object of the invention to provide nucleating agents in polymeric foam material at levels that maximize advantageous results. It is yet another object of the invention to provide non-batch-process HDPE foams of high quality.

#### Summary of the Invention

The present invention provides a series of articles, systems, devices, and methods associated with polymeric foam, blow-molded articles, foams including nucleating agents, and non-batch HDPE foams. Many of the articles, systems, devices, and methods can be used in conjunction with each other.

In one aspect, the invention provides an article. In one embodiment, an article is provided comprising a blow-molded, foam, microcellular, polymeric article.

In another embodiment, the invention provides an extruded, microcellular parison suitable for blow-molding.

In another aspect, the invention provides systems. One system includes extrusion apparatus having an extruder with an inlet designed to receive a precursor of polymeric microcellular material, constructed and arranged to provide a single-phase, non-nucleated solution of polymeric material and a blowing agent. A blow-molding forming die is fluidly connected to the extruder and has an outlet designed to release a parison of microcellular material. The apparatus includes an enclosed passageway connecting the extruder inlet to a blow molding forming die outlet. The passageway includes a nucleating pathway having

length and cross-sectional dimensions selected to create, in a single-phase, non-nucleated solution of blowing agent and fluid polymeric material, a pressure drop at a rate sufficient to cause microcellular nucleation. A blow mold also is included, and is positionable to receive a parison of microcellular material from the die outlet.

5           In another embodiment, a system is provided that includes an extruder constructed and arranged to provide a polymeric foam precursor material, and an accumulator associated with the extruder. The accumulator is able to receive polymeric foam precursor material from the extruder and to accumulate a charge of polymeric foam precursor material. Blow molding apparatus also is provided in this system, and is positionable to receive a product of the  
10 accumulator, via a forming die. The blow molding apparatus is constructed and arranged to blow mold the material to form a blow-molded foam polymeric article.

          In another embodiment a system that includes a combination of some aspects described above is provided. The system includes an extruder having an inlet to receive a precursor of polymeric microcellular material that is constructed and arranged to provide a  
15 single-phase non-nucleated solution of polymeric material and a blowing agent. An accumulator is provided and is positionable to receive polymeric foam precursor material from the extruder and to accumulate a charge of the polymeric foam precursor material. A blow-molding forming die is fluidly connected to the accumulator and has an outlet designed to release a parison of microcellular material. A blow mold is positionable to receive a  
20 parison of microcellular material from the die outlet and is constructed and arranged to form a blow-molded, foam, microcellular, polymeric article. The apparatus includes an enclosed passageway connecting the extruder inlet with the die outlet, the passageway including a nucleating pathway defined above.

          In another aspect, the invention provides a forming die device. The die includes an  
25 inlet at an upstream end constructed and arranged to receive a single-phase, homogeneous solution of polymeric material and a blowing agent that is a gas under ambient conditions, and an outlet at a downstream end thereof, defining a die gap, for releasing foamed polymeric material. A fluid pathway connects the inlet with the outlet and includes a nucleating pathway. The die is constructed and arranged to vary the width of the die gap during  
30 extrusion while maintaining a constant nucleating pathway gap.

          In another aspect, the invention provides a series of methods. In one embodiment, a method is provided that involves extruding polymeric foam extrudate from an extruder die



while varying the thickness of the extrudate.

In another embodiment, a method is provided that includes providing an extrudate polymeric microcellular foam parison and subjecting the parison to blow molding conditions.

In another embodiment, a method is provided that involves extruding a polymeric  
5 foam extrudate from an extruder die in a machine direction while varying the temperature of the extrudate exiting the die. An extrudate thereby is formed having a first portion and a second portion spaced from the first portion in the machine direction, the first portion and second portion differing in material density by a factor of at least 1.1.

In another embodiment, a method is provided that involves subjecting a foam  
10 polymeric parison to relatively severe blow-molding conditions while maintaining relatively constant density in the parison. A parison can be subjected to blow-molding conditions of at least about 15 psi thereby expanding at least a portion of the parison at least about 50% in circumference. This takes place while the density of the parison remains relatively constant, in particular the density is increased by no more than about 20%.

15 Another aspect of the invention involves a process for producing a foam, and a microcellular foam, that includes a midlevel amount of nucleating agent. The microcellular foams can be produced in typical polymer processing techniques such as extrusion, injection molding and blow molding. The foams exhibit excellent mechanical properties and can be formed over a broad range of density into a number of different foam articles.

20 In this aspect of the invention a method is provided of forming a microcellular article. The method includes conveying polymeric material in a downstream direction in a polymer processing apparatus. The polymeric material includes a semicrystalline polymer, and a nucleating agent in an amount between about 2.5 and about 7 weight percent by weight of the polymeric material. The method further includes forming a microcellular article from the  
25 polymeric material.

In certain embodiments of this aspect, the process further includes the step of introducing blowing agent into the polymeric material in the polymer processing apparatus in an amount less than 1.5 weight percent by weight of the polymeric material, to form a solution of blowing agent and polymeric material. In certain embodiments, the process further  
30 includes the step of inducing a pressure drop rate of less than 1.0 GPa/s in the solution of blowing agent and polymeric material.

In another aspect, the invention provides a microcellular polymeric article including a

matrix of polymeric material including a plurality of cells having an average cell size of less than about 60 microns. The polymeric material includes a semicrystalline polymer and a nucleating agent in an amount between about 2.5 and about 7 weight percent, by weight of the polymeric material.

5           Among other advantages, certain embodiments of the invention provide a viable process for producing the microcellular foam articles with low blowing agent percentages and/or low pressure drop rates due to the presence of the nucleating agent. Using low blowing agent percentages results in cost savings associated with the blowing agent and also may improve the surface quality of resulting microcellular articles. Employing low pressure drop  
10 rates as opposed to high pressure drop rates generally permits greater freedom in die design and, in some cases, allows for the production of foam articles at thicker cross-sectional dimensions.

Different embodiments of the invention also provide processes for the production of a variety of different types of foam articles, for example, extruded articles, blow molded  
15 articles, and injection molded articles, from a variety of different semi-crystalline polymeric materials.

Furthermore, the invention provides a microcellular foam that includes nucleating agents at high enough levels, between 2.5% and 7% by weight polymeric material, to effectively function as filler that replaces solid plastic in a non-negligible amount. Replacing  
20 solid plastic with these agents can result in material cost savings and mechanical property enhancement.

In addition, in many cases the microcellular foams have uniform and fine cell structures despite the presence of the inorganic particles. The interconnectivity between cells is minimal, in many embodiments. Also, the foams can be produced over a range of  
25 densities. In particular, relatively high density foams can be produced having properties comparable to the solid, unfoamed plastic.

In another aspect, the invention provides a foam article that includes a matrix of polymeric material including a plurality of cells. The polymeric material consists essentially of high-density polyethylene and is essentially free of residual chemical blowing agent and  
30 reaction-by-products of chemical blowing agent. The article has a shape essentially identical to that of a continuous extrudate or the interior of a mold.

In another aspect, the invention provides a method of forming a foam article. The

method includes the step of conveying polymeric material in a downstream direction in a polymer processing apparatus. The polymeric material consists essentially of high-density polyethylene. The method further includes the steps of introducing a physical blowing agent into the polymeric material in the polymer processing apparatus and forming a foam article  
5 from the polymeric material.

The invention also provides a method of producing HDPE foams with a physical blowing agent. In many foam processes, it is advantageous to use physical blowing agents instead of chemical blowing agents. For instance, physical blowing agents are often less expensive than chemical blowing agents. In addition, physical blowing agents do not  
10 introduce reactive materials into the article that may interfere with effective recycling of the articles. Finally, processes using physical blowing agents are more efficient and reliable, not having to depend on a chemical reaction to determine the amount of blowing agent released during the foaming process.

Furthermore, the invention provides an HDPE foam containing low amounts of, or  
15 essentially free of residual chemical blowing agent and reaction-by-products of chemical blowing agents. In some cases, the presence of residual chemical blowing agents and reaction-by-products of chemical blowing agents in a material is detrimental and can restrict its use. The HDPE foams, in accordance to the invention, are advantageously suitable for applications, such as food packaging, and are more easily recycled without adverse effects.

20 In another aspect the invention provides specific die designs useful for making high quality, microcellular, polymeric extrudate. The die can be provided as part of a system of extrusion. The die includes a nucleating pathway that decreases in cross-section in a downstream direction with an included angle of greater than  $4^\circ$ .

In another embodiment a forming die according to this aspect of the invention includes  
25 a nucleating pathway constructed such that when a single-phase, non-nucleated solution of polymeric material and blowing agent is introduced into the die and conveyed through the die at a flow rate of about 100 pounds per hour, nucleation of the solution occurs to form a nucleated polymeric stream that is released from the die in a period of time of no more than about 0.002 second after nucleation.

30 In another embodiment of this aspect of the invention a method is provided that involves introducing a single-phase, non-nucleated solution of polymeric material and blowing agent into a polymer forming die. Within the die the solution is nucleated to form a

nucleated polymeric stream. The stream is released as a polymeric microcellular extrudate from an outlet of the die in a period of time of no more than about 0.002 second after nucleation.

Other advantages, novel features, and objects of the invention will become apparent from the following detailed description of the invention when considered in conjunction with the accompanying drawings, which are schematic and which are not intended to be drawn to scale. In the figures, each identical or nearly identical component that is illustrated in various figures is represented by a single numeral. For purposes of clarity, not every component is labeled in every figure, nor is every component of each embodiment of the invention shown where illustration is not necessary to allow those of ordinary skill in the art to understand the invention.

#### Brief Description of the Drawings

Fig. 1 is a schematic illustration of an injection blow molding system of the invention;

Fig. 2 is a schematic illustration of a die for the injection blow molding system of Fig. 1;

Fig. 3 is a schematic illustration of the die of Fig. 2, adjusted to extrude relatively thicker microcellular material;

Fig. 4 is a schematic illustration of another embodiment of the die of Fig. 2;

Fig. 5 illustrates a multihole blowing agent feed orifice arrangement and extrusion screw;

Fig. 6 illustrates an alternative embodiment of an extrusion system for producing microcellular foam;

Fig. 7 is a photocopy of an SEM micrograph of a cross-section of the material produced in Example 4;

Fig. 8 is a photocopy of an SEM micrograph of a cross-section of the material produced in Example 5;

Fig. 9 is a photocopy of an SEM micrograph of a cross-section of the material produced in Example 6;

Fig. 10 is a photocopy of an SEM micrograph of a cross-section of the material produced in Example 7;

Fig. 11 is a photocopy of an SEM micrograph of a cross-section of the material

produced in Example 8;

Fig. 12 is a photocopy of an SEM micrograph of a cross-section of the material produced in Example 9; and

Fig. 13 is a photocopy of an SEM micrograph of a cross-section of the material  
5 produced in Example 10.

#### Detailed Description of the Invention

Commonly owned, co-pending international patent publication no. WO 98/08667 published March 5, 1998, commonly owned, co-pending international patent publication  
10 no. WO 98/31521 published July 23, 1998, commonly owned, co-pending U.S. provisional patent application serial no. 60/068,173 entitled "Microcellular Extrusion/Blow Molding Process and Article Made Thereby", filed December 19, 1997, commonly owned, co-pending U.S. provisional patent application serial no. 60/107,754 entitled "Microcellular Extrusion/Blow Molding Process and Article Made Thereby", filed November 10, 1998, all  
15 are incorporated by reference.

The various embodiments and aspects of the invention will be better understood from the following definitions. As used herein, "nucleation" defines a process by which a homogeneous, single-phase solution of polymeric material, in which is dissolved molecules of a species that is a gas under ambient conditions, undergoes formations of clusters of  
20 molecules of the species that define "nucleation sites", from which cells will grow. That is, "nucleation" means a change from a homogeneous, single-phase solution to a mixture in which sites of aggregation of at least several molecules of blowing agent are formed. Nucleation defines that transitory state when gas, in solution in a polymer melt, comes out of solution to form a suspension of bubbles within the polymer melt. Generally this transition  
25 state is forced to occur by changing the solubility of the polymer melt from a state of sufficient solubility to contain a certain quantity of gas in solution to a state of insufficient solubility to contain that same quantity of gas in solution. Nucleation can be effected by subjecting the homogeneous, single-phase solution to rapid thermodynamic instability, such as rapid temperature change, rapid pressure drop, or both. Rapid pressure drop can be created  
30 using a nucleating pathway, defined below. Rapid temperature change can be created using a heated portion of an extruder, a hot glycerine bath, or the like.

A "nucleating agent" is a dispersed agent, such as talc or other filler particles, added to

a polymer and able to promote formation of nucleation sites from a single-phase, homogeneous solution. Thus "nucleation sites" do not define locations, within a polymer, at which nucleating agent particles reside. A "filler" is a dispersed particle added to replace solid plastic.

5 "Nucleated" refers to a state of a fluid polymeric material that had contained a single-phase, homogeneous solution including a dissolved species that is a gas under ambient conditions, following an event (typically thermodynamic instability) leading to the formation of nucleation sites. "Non-nucleated" refers to a state defined by a homogeneous, single-phase solution of polymeric material and dissolved species that is a gas under ambient conditions,  
10 absent nucleation sites. A "non-nucleated" material can include nucleating agent such as talc.

A "polymeric material/blowing agent mixture" can be a single-phase, non-nucleated solution of at least the two, a nucleated solution of at least the two, or a mixture in which blowing agent cells have grown.

"Essentially closed-cell" microcellular material is meant to define material that, at a  
15 thickness of about 200 microns, contains no connected cell pathway through the material.

"Nucleating pathway" is meant to define a pathway that forms part of microcellular polymeric foam extrusion apparatus and in which, under conditions in which the apparatus is designed to operate (typically at pressures of from about 1500 to about 30,000 psi upstream of the nucleator and at flow rates of greater than about 10 pounds polymeric material per hour),  
20 the pressure of a single-phase solution of polymeric material admixed with blowing agent in the system drops below the saturation pressure for the particular blowing agent concentration at a rate or rates facilitating rapid nucleation. A nucleating pathway defines, optionally with other nucleating pathways, a nucleation or nucleating region of a device of the invention.

"Reinforcing agent", as used herein, refers to auxiliary, essentially solid material  
25 constructed and arranged to add dimensional stability, or strength or toughness, to material. Such agents are typified by fibrous material as described in U.S. Patent Nos. 4,643,940 and 4,426,470. "Reinforcing agent" does not, by definition, necessarily include filler or other additives that are not constructed and arranged to add dimensional stability. Those of ordinary skill in the art can test an additive to determine whether it is a reinforcing agent in  
30 connection with a particular material.

In preferred embodiments, microcellular material of the invention is produced having average cell size of less than about 60 microns or 50 microns. In some embodiments

particularly small cell size is desired, and in these embodiments material of the invention has average cell size of less than about 30 microns, more preferably less than about 20 microns, more preferably less than about 10 microns, and more preferably still less than about 5 microns. The microcellular material preferably has a maximum cell size of about 100 microns or preferably less than about 75 microns. In embodiments where particularly small cell size is desired, the material can have maximum cell size of about 50 microns, more preferably about 35 microns, and more preferably still about 25 microns. A set of embodiments includes all combinations of these noted average cell sizes and maximum cell sizes. For example, one embodiment in this set of embodiments includes microcellular material having an average cell size of less than about 30 microns with a maximum cell size of about 50 microns, and as another example an average cell size of less than about 30 microns with a maximum cell size of about 35 microns, etc. That is, microcellular material designed for a variety of purposes can be produced having a particular combination of average cell size and a maximum cell size preferable for that purpose. Control of cell size is described in greater detail below.

In one aspect, the present invention provides systems and techniques for extrusion blow molding of microcellular and other polymeric foam material, and microcellular parisons suitable for blow molding, that is, parisons that can be subjected to blow molding conditions as described herein to produce articles as described herein. In particular, the invention provides techniques for production of lightweight, strong microcellular articles that can be blow molded to form microcellular polymeric blow molded parisons that can have particularly thin walls. It is a feature that articles of the invention can be produced that are free of a non-foam, structurally-supporting material positioned to support the foam article. This means that where a plastic bottle, for example, is produced, the walls of the bottle can be composed entirely of the microcellular foam material, without an auxiliary layer of solid supporting plastic.

The invention involves the discovery that microcellular material overcomes problems associated with certain prior art techniques, in particular, problems in blow molding associated with the inherent relative weakness of conventional thermoplastic polymer foams. Microcellular material of the present invention surprisingly can be blow molded at relatively high pressures, in particular a pressure of at least about 1.5 bar internal of a microcellular parison, in some cases at least about 2.5 bar, in some cases at least about 5 bar, in some cases at least about 7 bar, and in some cases still at least about 10 bar internal of the parison. This

strength is achieved even in microcellular parisons including at least some portion having a void volume of at least about 5%, preferably at least about 10%, preferably at least about 20%, more preferably at least about 30%, and in some cases as high as at least about 50% or at least about 70%, even without reinforcing agents, and while forming final microcellular foam products having thin walls, in particular at thicknesses described below. In this regard, microcellular blow molded articles are produced having less than about 10% reinforcing agent by weight, more preferably less than about 5% reinforcing agent, more preferably still less than about 2%, and in particularly preferred embodiments the articles of the invention are essentially free of reinforcing agent.

10 It also has been surprisingly found that microcellular foam parisons of the invention can be blow molded under relatively severe conditions without a significant change in density in the material. Specifically, a foam parison of the invention can be subjected to blow-molding conditions of at least about 15 psi, or 18 or 20 psi or other pressures described herein, thereby expanding at least a portion of the parison by at least about 50% and forming a blow-molded article while maintaining a relatively constant density in the material, specifically, 15 increasing the density of the parison by no more than about 20% in going from the parison to the blow-molded article. In preferred embodiments at least a portion of the parison is expanded by at least about 75%, 100%, 150%, 200%, 300%, or at least about 400% in circumference while the density of the parison is increased by no more than about 15%, 10%, 20 8%, 5% or preferably 3%.

Without wishing to be bound by any theory, it is believed that the microcellular material of the invention is particularly suitable to the relatively harsh conditions of blow molding because the cells of the invention, of very small size, are not easily crushed or otherwise distorted. It is believed that as the size of the cells decreases, the force required to cause collapse of an individual cell significantly increases.

The die of the invention can be shaped and controlled to produce blow-molded articles that have sections with differing thicknesses and sections with differing void volume. For example, a blow-molded, square-shaped bottle can be formed that has sections defining its corners that are thicker than remaining portions of the bottle wall. The thicker portions can, e.g., have a void volume of 50% and the thinner wall a void volume of about 10%. These thicker regions are reinforcing regions. Reinforcing regions also can be provided at corners that define the boundary between the bottle wall and the bottle bottom, or the bottle wall and



bottle top, or vertical corners, or all of these.

It is a feature of the present invention that strong, thin-walled articles can be produced that are opaque without the use of opacifiers. This is because polymeric foam diffracts light, thus it is essentially opaque and has a white appearance. It is a feature of the invention that microcellular foams are more opaque, and uniformly so, than conventional foams. This is a significant advantage in connection with articles constructed and arranged to contain material that is subject to destruction upon exposure to light, such as food containers. Such material can involve food consumable by animals such as humans, containing vitamins that can be destroyed upon exposure to light. In a preferred embodiment the invention provides microcellular blow-molded milk containers, as it is particularly known that vitamins in milk can be lost upon exposure to fluorescent light. Milk bottle container producers are reported to introduce pigments into milk bottles, typically high density polyethylene milk bottles, so as to protect milk from vitamin-destroying light. However, pigmented polymeric material is less amenable to recycling. The present invention provides, in one embodiment, thin, opaque, blow-molded containers that include less than about 1% by weight auxiliary opacifer, preferably less than about 0.05% by weight auxiliary opacifer, and more preferably still material that is essentially free of auxiliary opacifer. "Auxiliary opacifer", in the present invention, is meant to define pigments, dyes, or other species that are designed specifically to absorb light, or talc or other materials that can block or diffract light. Those of ordinary skill in the art can test whether an additive is an opacifer. Microcellular blow molded articles of the invention have the appearance of essentially solid, white, plastic articles, which offers significant commercial appeal.

Material of the present invention is, in preferred embodiments, blown with a physical blowing agent such as an atmospheric gas, in particular carbon dioxide, and thus in this embodiment does not require the added expense and complication of formulating a polymeric precursor to include a chemical blowing agent, that is, a species that will react under extrusion conditions to form a blowing agent. Since foams blown with chemical blowing agents inherently include a residual, unreacted chemical blowing agent after a final foam product has been produced, as well as chemical by-products of the reaction that forms a blowing agent, material of the present invention in this set of embodiments includes residual chemical blowing agent, or reaction by-product of chemical blowing agent, in an amount less than that inherently found in articles blown with 0.1% by weight chemical blowing agent or more,

preferably in an amount less than that inherently found in articles blown with 0.05% by weight chemical blowing agent or more. In particularly preferred embodiments, the material is characterized by being essentially free of residual chemical blowing agent or free of reaction by-products of chemical blowing agent. That is, they include less residual chemical blowing agent or by-product that is inherently found in articles blown with any chemical blowing agent.

One advantage of embodiments in which a chemical blowing agent is not used or used in very minute quantities is that recyclability of product is maximized. Use of a chemical blowing agent typically reduces the attractiveness of a polymer to recycling since residual chemical blowing agent and blowing agent by-products contribute to non-uniformity in the recyclable material pool.

As mentioned, the present invention provides for blow-molding of relatively high void-volume articles having thin walls, in some embodiments. In particular, the articles of the invention have a wall thickness less than about 0.100 inch, more preferably less than about 0.075 inch, more preferably less than about 0.050 inch, more preferably still less than about 0.040 inch, and in some cases as low as 0.025 inch, 0.015 inch, or 0.010 inch or less.

In one set of embodiments the invention represents the solution of problems associated with the extrusion of polymeric foam parisons having a variety of conventional cell sizes, in addition to microcellular parisons, for blow molding, that must be varied in thickness or density. In this set of embodiments the invention provides techniques for producing a polymeric foam parison, which can be microcellular, that varies in thickness, and/or varies in material density, along its length. Specifically, the preferred extruded polymeric foam parison has a first portion and a second portion spaced from the first portion in the parison machine direction, the first portion and the second portion differing in thickness by a factor of at least about 1.1. In other embodiments the first and second portions differ in thickness by factors of at least about 1.3, 1.5, or 1.7. The first and second portions can differ in material density by a factor of at least about 1.1, and in other embodiments by a factor of at least about 1.3, 1.5, or 1.7. The parison is suitable for blow-molding to produce an article including a first portion expanded to a first extent and a second portion expanded at least 1.5 times the first extent, the first and second portions, after expansion, differing in each of thickness, material density, and cellular density by no more than about 5%. In this technique, a polymeric extrusion die is provided that is constructed and arranged to subject a flowing, single-phase solution of molten

polymeric material and physical blowing agent that is a gas under atmospheric conditions to a consistent pressure drop rate while varying the annular gap at the die exit to facilitate production of a microcellular polymeric foam parison that varies in thickness along its length. The die is effective in this task by providing the physical separation of nucleation from shaping. That is, nucleation occurs in a consistent manner (an essentially constant pressure drop rate) upstream of shaping, thus differential shaping does not effect cell size, cell density, or material density, substantially. Alternatively or in addition, the parison can be subjected, during extrusion, to differing temperature resulting in differential material density as a function of position in the machine direction.

Referring now to Fig. 1, an extrusion blow molding system 6 of the present invention is illustrated schematically. System 6 includes an extruder 30 fluidly connected to a blow-molding extrusion die 10, and a blow mold 12 positionable to receive a parison of microcellular material from the outlet of the die. Blow mold 12 can be a conventional mold, and is not described in detail here except to say that foam parisons of the invention can be blow molded without heating, thus mold 12 need not include auxiliary heating systems. That is, a foam parison of the invention, preferably a microcellular foam parison, can be extruded and then blow molded in mold 12 without applying heat to the parison in the mold. Extruder 30 includes a barrel 39 having a first, upstream end 37, and a second, downstream end 36 connected to die 10. Mounted for rotation within barrel 39 is a screw 38 operably connected, at its upstream end, to a drive motor 40. Although not shown in detail, screw 38 includes feed, transition, gas injection, mixing, and metering sections. A polymer processing space 35 is defined between the screw and the barrel in which polymeric material is urged downstream.

Positioned along barrel 39, optionally, are temperature control units 42. Control units 42 can be electrical heaters, can include passageways for temperature control fluid, and or the like. Units 42 can be used to heat a stream of pelletized or fluid polymeric material within the barrel to facilitate melting, and/or to cool the stream to control viscosity and, in some cases, blowing agent solubility. The temperature control units can operate differently at different locations along the barrel, that is, to heat at one or more locations, and to cool at one or more different locations. Any number of temperature control units can be provided. Temperature control units also can be supplied to heat a die to which the extrusion system is connected.

Barrel 39 is constructed and arranged to receive a precursor of polymeric material. As used herein, "precursor of polymeric material" is meant to include all materials that are fluid,

or can form a fluid and that subsequently can harden to form a microcellular polymeric article. Typically, the precursor is defined by thermoplastic polymer pellets, but can include other species. For example, in one embodiment the precursor can be defined by species that will react to form microcellular polymeric material as described, under a variety of conditions.

5 The invention is meant to embrace production of microcellular material from any combination of species that together can react to form a polymer, typically monomers or low-molecular-weight polymeric precursors which are mixed and foamed as the reaction takes place. Preferably, a thermoplastic polymer or combination of thermoplastic polymers is selected from among amorphous, semicrystalline, and crystalline material including polyaromatics  
10 such as styrenic polymers including polystyrene, polyolefins such as polyethylene and polypropylene, fluoropolymers, crosslinkable polyolefins, and polyamides.

Typically, introduction of the pre-polymeric precursor utilizes a standard hopper 44 for containing pelletized polymeric material to be fed into the extruder barrel through orifice 46, although a precursor can be a fluid prepolymeric material injected through an orifice and  
15 polymerized within the barrel via, for example, auxiliary polymerization agents. In connection with the present invention, it is important only that a fluid stream of polymeric material be established in the system. From hopper 44 pellets are received into the feed section of screw and conveyed in a downstream direction in polymer processing space 35 as the screw rotates. Heat from extrusion barrel 39 and shear forces arising from the rotating  
20 screw, act to soften the pellets within the transition section. Typically, by the end of the first mixing section the softened pellets have been gelated, that is, welded together to form a uniform fluid stream substantially free of air pockets.

Immediately downstream of the downstream end 48 of screw 38 in Fig. 1 is a region  
50 which can be a temperature adjustment and control region, auxiliary mixing region,  
25 auxiliary pumping region, or the like. For example, region 50 can include temperature control units to adjust the temperature of a fluid polymeric stream prior to nucleation, as described below. Region 50 can include instead, or in addition, additional, standard mixing units (not shown), or a flow-control unit such as a gear pump (not shown). In another embodiment, region 50 can be replaced by a second screw in tandem which can include a cooling region.

30 Microcellular material production according to the present invention preferably uses a physical blowing agent, that is, an agent that is a gas under ambient conditions. However, chemical blowing agents can be used and can be formulated with polymeric pellets introduced

into hopper 44. Suitable chemical blowing agents include those typically relatively low molecular weight organic compounds that decompose at a critical temperature or another condition achievable in extrusion and release a gas or gases such as nitrogen, carbon dioxide, or carbon monoxide. Examples include azo compounds such as azo dicarbonamide.

5 In embodiments in which a physical blowing agent is used, along barrel 39 of extruder 30 is a port 54 in fluid communication with a source 56 of a physical blowing agent. Any of a wide variety of physical blowing agents known to those of ordinary skill in the art such as hydrocarbons, chlorofluorocarbons, nitrogen, carbon dioxide, and the like, and mixtures, can be used in connection with the invention and, according to a preferred embodiment, source 56  
10 provides carbon dioxide, or nitrogen, or a mixture thereof as a blowing agent. Supercritical fluid blowing agents are preferred, particularly supercritical carbon dioxide and/or nitrogen. In particularly preferred embodiments solely carbon dioxide or nitrogen, respectively, is used. Where a supercritical fluid blowing agent is used, a single-phase solution of polymeric material and blowing agent is created having viscosity reduced to the extent that extrusion and  
15 blow-molding is readily accomplished even with material of melt flow no more than about 0.2 g/10 min. A pressure and metering device 58 typically is provided between blowing agent source 56 and port 54. Device 58 can be used to meter the blowing agent so as to control the amount of the blowing agent in the polymeric stream within the extruder to maintain a level of blowing agent at a particular level. In a preferred embodiment, device 58 meters the mass  
20 flow rate of the blowing agent. The blowing agent is generally less than about 15% by weight of polymeric stream and blowing agent. According to one set of embodiments, blowing agent is added in an amount of between about 1% and 15% by weight, preferably between about 3% and 12% by weight, more preferably between about 5% and 10% by weight, more preferably still between about 7% and 9% by weight, based on the weight of the polymeric stream and  
25 blowing agent. In other embodiments very low levels of blowing agents are suitable, for example less than about 3%, less than about 2%, or less than about 1.5% by weight blowing agent. These blowing agent levels can find use, in some instances, where a nucleating agent is used.

The systems and methods of the invention allow formation of microcellular material  
30 without use of a nucleating agent. But such agents can be used and, in some embodiments, polymeric material including a nucleating agent such as talc is blow molded. It has been discovered, in accordance with the invention, that polymeric material including a filler such as

talc adds to the ability to make thicker parts at higher pressures, and improves cell structure. Although not wishing to be bound by any theory, it is believed that use of a nucleating agent such as talc reduces the amount of blowing agent such as carbon dioxide or nitrogen needed, thus the material will have a higher viscosity (since carbon dioxide or nitrogen reduces  
5 viscosity in such material). Therefore, the size of nucleating pathways and exit gaps can be increased while maintaining similar extrusion conditions otherwise, resulting in thicker parts. In addition, a nucleating agent such as talc adds to the viscosity of molten polymeric material inherently, allowing formation of thicker parts. In this embodiment of the invention nucleating agent such as talc can be added in an amount of at least 1%, or 2%, or 4%, 5.5% or  
10 even 7% or more. In one embodiment talc is added within a range of from 2.5% to 7%, which gives specific advantages described more fully below.

In some embodiments carbon dioxide is used in combination with other blowing agents such as nitrogen, and in other embodiments carbon dioxide is used alone with no other blowing agents present. In other embodiments carbon dioxide can be used with other blowing  
15 agents so long as the other blowing agents do not materially alter the blowing process. When nitrogen is used, similarly it can be used alone, in combination with another blowing agent that adds to or changes the blowing agent properties, or in combination with another agent that does not materially change the blowing process.

The pressure and metering device can be connected to a controller (not shown) that  
20 also is connected to drive motor 40 and/or a drive mechanism of a gear pump (not shown) to control metering of blowing agent in relationship to flow of polymeric material to very precisely control the weight percent blowing agent in the fluid polymeric mixture.

The described arrangement facilitates a method that is practiced according to several  
25 embodiments of the invention, in combination with blow molding. The method involves introducing, into fluid polymeric material flowing at a rate of at least about 10 lbs/hr., a blowing agent that is a gas under ambient conditions and, in a period of less than about 1 minute, creating a single-phase solution of the blowing agent fluid in the polymer. The blowing agent fluid is present in the solution in an amount of at least about 2.0% by weight based on the weight of the solution in this arrangement. In preferred embodiments, the rate of  
30 flow of the fluid polymeric material is at least about 40 or 60 lbs/hr., more preferably at least about 80 lbs/hr., and in a particularly preferred embodiment greater than at least about 100 lbs/hr., and the blowing agent fluid is added and a single-phase solution formed within one

minute with blowing agent present in the solution in an amount of at least about 3% by weight, more preferably at least about 5% by weight, more preferably at least about 7%, and more preferably still at least about 10% (although, as mentioned, in a another set of preferred embodiments lower levels of blowing agent are used). In these arrangements, at least about  
5 2.4 lbs per hour blowing agent, preferably CO<sub>2</sub>, is introduced into the fluid stream and admixed therein to form a single-phase solution. The rate of introduction of blowing agent is matched with the rate of flow of polymer to achieve the optimum blowing agent concentration.

Although port 54 can be located at any of a variety of locations along the barrel,  
10 according to a preferred embodiment it is located just upstream from a mixing section 60 of the screw and at a location 62 of the screw where the screw includes unbroken flights.

Referring now to Fig. 2, a die 10 of the invention is illustrated schematically in cross-section and includes an annular outer die body 26 surrounding an inner die body 24 which, in turn, surrounds an inner mandrel 31. The die includes a fluid inlet 14, constructed and  
15 arranged to receive a single-phase, homogeneous solution of polymeric fluid and blowing agent that is a gas under ambient conditions, defined by the junction of the outlet of extruder 30 and a sidewall entrance of the die. Fluid inlet 14 communicates with an annular ring-like void 18 between the outer die body and inner die body that is in fluid communication with an annular channel 20 defined as a gap between the inner die body 24 and outer die body 26.  
20 Channel 20 fluidly communicates with an annular section 28 of the die that is of greater width than that of channel 20. Section 28 communicates, in turn, with a narrowed annular portion 29 defining a nucleating pathway having a gap 22 that is of a dimension that creates a rapid pressure drop facilitating nucleation of the single-phase solution fed to the die. At its downstream end nucleating pathway 29 fluidly communicates with an exit 32 of the die  
25 having a gap 34. Nucleating pathway 29, as illustrated, has an essentially constant cross-sectional dimension along its length. The pathway can change in cross-sectional dimension along its length as well, for example decreasing in cross-sectional dimension in a downstream direction for particularly high pressure drop rates, as disclosed in U.S. patent application serial no. 08/777,709 and International patent application serial no. PCT/US97/15088, incorporated  
30 by reference. Where the pathway decreases in cross-sectional dimension in a downstream direction, a single-phase solution can be continuously nucleated by experiencing continuously decreasing pressure within successive, continuous portions of the flowing, single-phase

stream at a rate which increases.

Die 10 is constructed such that inner die body 24 can move axially relative to outer die body 26. Inner die body 24 can move from an upstream position as illustrated in Fig. 2 to a downstream position in which it almost fills a region indicated as 25. Thus, when inner die body 24 is positioned in an upstream position as illustrated in Fig. 2, region 25 defines an accumulator.

In operation, a single-phase solution 23 of polymeric material and blowing agent is fed from extruder 30 to the die 10, first into annular ring 18, then through channel 20, accumulator 25 (to the extent that inner die body 24 is positioned upstream) and section 28 of the die as a single-phase, non-nucleated solution, is nucleated through a rapid pressure drop occurring at nucleating pathway 29, and is extruded at exit 32 as a parison suitable for blow molding. When it is desired to use the accumulating feature of die 10, exit 32 can be closed (described below) and non-nucleated, single-phase solution 23 of polymeric material and blowing agent can be fed from extruder 30 into accumulator 25 while inner die body 24 moves in an upstream direction. A load can be applied to inner die body 24 in a downstream direction, during this procedure, to maintain in accumulator 25 an essentially constant pressure that maintains the polymer/blowing agent solution in a non-nucleated, single-phase condition. Then, exit 32 can be opened and inner die body 24 driven in a downstream direction to nucleate and extrude a microcellular parison. This feature allows for an extruder to be run continuously while parison extrusion occurs periodically.

While polymeric material nucleated in nucleating pathway 29 can include nucleating agent in some embodiments, in other embodiments no nucleating agent is used. In either case, the pathway is constructed so as to be able to create sites of nucleation in the absence of nucleating agent whether or not nucleating agent is present. In particular, the nucleating pathway has dimensions creating a desired pressure drop rate through the pathway. In one set of embodiments, the pressure drop rate is relatively high, and a wide range of pressure drop rates are achievable. A pressure drop rate can be created, through the pathway, of at least about 0.1 GPa/sec in molten polymeric material admixed homogeneously with about 6 wt % CO<sub>2</sub> passing through the pathway of a rate of about 40 pounds fluid per hour. Preferably, the dimensions create a pressure drop rate through the pathway of at least about 0.3 GPa/sec under these conditions, more preferably at least about 1 GPa/sec, more preferably at least about 3 GPa/sec, more preferably at least about 5 GPa/sec, and more preferably still at least



about 7,10, or 15 GPa/sec. The nucleator is constructed and arranged to subject the flowing stream to a pressure drop at a rate sufficient to create sites of nucleation at a density of at least about  $10^7$  or, preferably,  $10^8$  sites/cm<sup>3</sup>. The apparatus is constructed and arranged to continuously nucleate a fluid stream of single-phase solution of polymeric material and  
5 flowing agent flowing at a rate of at least 20 lbs/hour, preferably at least about 40 lbs/hour, more preferably at least about 60 lbs/hour, more preferably at least about 80 lbs/hour, and more preferably still at least about 100, 200, or 400 lbs/hour.

Die 10 is constructed such that mandrel 31 can move axially relative to the remainder of the die. This allows for exit 32 to be closed, if desired, by moving mandrel 31 in an  
10 upstream direction so as to seal the inner die lip against the outer die lip.

Referring now to Fig. 3, die 10 is illustrated with mandrel 31 extended distally such that exit 32 includes a gap 33 that is significantly widened relative to gap 34 as illustrated in Fig. 2. This can be effected while maintaining a constant gap 22 in nucleating section 29 of the die. Thus, nucleation of the single-phase polymer/blowing agent fluid stream takes place  
15 at a constant pressure drop rate while the die can produce a parison that varies in thickness. A controller actuates the mandrel such that exit 32 widens and narrows to produce a parison having varied thickness as desired. A microcellular product varying in thickness in a machine direction while having essentially uniform microcellular structure as is produced using die 10 are described above.

20 The invention also allows co-extrusion of foam or microcellular foam articles. Although a die for extrusion of such an article with two or more layers is not illustrated, it can be clearly understood with reference to Fig. 2. A multi-layer extrusion die, in one embodiment, includes co-axial, separate, pathways defining nucleating sections that feed together into a single exit 32. That is, the die includes a nucleating section 29 as illustrated in  
25 Fig. 2, and an additional nucleating section spaced radially outwardly from nucleating section 29 and fed by a separate section similar to section 28. Simultaneous, separate nucleation of separate layers is followed by joining of the nucleated layers slightly before or at gap 32 where combination of the layers and shaping and ejection of the layers takes place.

According to another aspect of the invention a microcellular polymeric parison is  
30 extruded that differs in material density along its length. In this embodiment the parison can differ in thickness along its length, as well. This can be accomplished using the system illustrated in Fig. 4 in which die 10 is provided that is similar to the die of previous figures.

Die 10 need not necessarily include a mandrel that is movable axially during extrusion to produce a parison of varying thickness, but includes an air ring 52 for subjecting the parison, during extrusion, to varying conditions of cooling. The air ring can subject different portions of the parison to different cooling conditions, thus reducing cell growth in certain portions of the parison relative to other portions. In a similar manner, selected sections of the internal surface of the parison can be cooled by passing air through a channel 63 formed in mandrel 31 between an inner mandrel part 61 and an outer mandrel part 64. Internal air cooling can be used alternately or in conjunction with external air cooling via air ring 52. The resulting parison can be blow molded and can be created such that some sections are relatively higher in material density than others. Sections subjected to different cooling immediately post-extrusion experience different cell growth and therefore different density.

The system of Fig. 4 can be used also to produce a blow-molded article having increased density at locations where greater strength is required. For example, in a plastic beverage container including a threaded mouth for receiving a screw-on cap, the threaded mouth might desirably be made of higher material density for added strength than the remainder of the bottle.

It is one feature of the present invention that the microcellular extruded parison of the invention is better able to withstand blowing conditions than many prior art foam parisons. This is because of the greater resistance of smaller cells to the pressure exerted during blowing. Many prior art foams will exhibit cell collapse when exposed to blow molding conditions. However, as cell size decreases, greater pressure is required to cause cell collapse.

In one embodiment of the invention, a microcellular parison is co-extruded with an auxiliary polymeric layer that can be internal of or external of the microcellular parison, or both. The auxiliary material can be foam or non-foam and can be added to create a particular appearance (for example when a colored article is desired, a microcellular foam core can be covered with a colored, co-extruded layer). Also, a co-extruded layer may be added to provide good printability on an article or to provide a particular surface texture. Other characteristics such as chemical compatibility, and the like are contemplated. In some cases, a co-extruded layer may be used, internally or externally of a microcellular parison core, to isolate the core from internal contents of the article, or external environment. This can be useful to increase the use of recycled material in the core. The auxiliary, co-extruded layer, in preferred embodiments, is not necessary for structural support. That is, the microcellular

parison could be blow-molded and would provide adequate structural support on its own, and the co-extruded layer is for purposes of surface modification only. In one embodiment, an auxiliary non-foam, non-structurally-supporting layer is provided adjacent the foam article. This layer can be designed for specific barrier properties (for example, for compatibility with material to be contained in the article, Federal regulation requirements, etc.).

The production of blow-molded microcellular polymeric articles in accordance with the invention is surprising since desirable characteristics for polymers for blow molding are different from those characteristics desired in typical extrusion processes. For blow molding, typically high-molecular-weight, high-viscosity polymers are needed to withstand, successfully, blow molding conditions. In contrast, in standard extrusion it is desirable to use lower-molecular weight, lower-viscosity polymers for high throughput. Thus, extrusion blow molding includes an inherent dichotomy that adds even more complication when foams are used. For controlled foaming, higher-molecular weight, higher-viscosity polymers are favored to prevent uncontrolled foaming resulting in open-celled material.

The present invention provides successful high-throughput microcellular polymeric extrusion blow molding since higher-molecular weight polymers can be used while reducing viscosity via supercritical fluid blowing agent incorporation. Relatively high molecular weight polymers are reduced in viscosity via the supercritical fluid blowing agent for high-throughput extrusion, yet at extrusion and gasification of the blowing agent the high-molecular weight polymer provides the strength needed for well-controlled microcellular foaming. Therefore, as noted above, extrusion and blow molding of foam polymeric material, preferably microcellular foam polymeric material, can be accomplished with material of melt flow no more than about 0.2 g/10 min, preferably no more than about 0.12 g/10 min, more preferably no more than about 0.1 g/10 min.

In another aspect, the present invention provides a semi-crystalline microcellular foam having a midrange level of nucleating agent. The foam includes between about 2.5 weight percent and about 7 weight percent of these agents. In preferred embodiments, the foam includes between about 3 and about 7 weight percent nucleating agent, and in some embodiments between about 5 weight percent and about 7 weight percent nucleating agent. The level nucleating agent in the present foam is, generally, greater than the levels used as nucleating agents, flame retardents, or pigments in conventional foam processing. These semi-crystalline microcellular foams containing about 2.5-7 weight percent nucleating agent

can be used in connection with any of the blow molding aspects of the invention described above.

The nucleating agents can be any of a variety of materials and in any number of forms, as known in the art. In certain embodiments, the nucleating agents are inorganic solids such as those commonly used in the art, for example talc, calcium carbonate ( $\text{CaCO}_3$ ), titanium oxide ( $\text{TiO}_2$ ), barium sulfate ( $\text{BaSO}_4$ ), and, zinc sulfide ( $\text{ZnS}$ ). In certain embodiments, organic solids, such as cellulosic fibers, may also function as nucleating agents. The foams, in some cases, may include more than one type of nucleating agent such that the sum total of all of the nucleating agents is between about 2.5 weight percent and 7 weight percent. In particular, microcellular foams including both talc and titanium oxide have been produced.

Typically, the nucleating agents are particles, though in some cases the nucleating agents may be fibrous or have other forms. The nucleating particles can have a variety of shapes such as spherical, cylindrical, or planar. Generally, the particles have a size in the range of about 0.01 microns to about 10 microns, and more typically between about 0.1 microns and 1.0 microns. In some embodiments, the particles may be surface treated with a surfactant to enhance dispersibility within polymer melt and to prevent particle agglomeration.

In some cases, the nucleating agents, depending on their composition, may also function as pigments, flame retardants or any other typical additive. In the 2.5-7 weight percent range, the agents also function as fillers. That is, the nucleating agents replace solid plastic in a non-negligible amount which, in certain embodiments, leads to cost savings because filler is less expensive than the solid plastic. In certain embodiments, the agents also may enhance the mechanical properties of the microcellular foam. In some cases, the particles may enhance crystallinity.

The present microcellular foam including about 2.5-7 weight percent nucleating agent can be composed, at least in part, of any semi-crystalline polymer. Typical semi-crystalline polymers include, but are not limited to, the following materials: polyethylene terephthalate (PET), polylactic acid, nylon 6, nylon 6/6, polyethylene, polypropylene, syndiotactic polystyrene, and polyacetal. In certain cases, the semi-crystalline polymer may be blended with non-semi-crystalline polymers. The semi-crystalline polymer may also be blended with other semi-crystalline polymers. In preferred cases, the semi-crystalline material is a polyolefin. In some cases, the semi-crystalline material is polypropylene. Polypropylene may

be present as one of multiple polymeric components. In other embodiments, the polymeric material can consist essentially of polypropylene, that is, the polymeric material includes no other polymeric components other than polypropylene, but may include other additives, as described further below, in addition to the nucleating agent. In another set of preferred  
5 embodiments the semi-crystalline material is high-density polyethylene. High-density polyethylene, in some cases, is present as one of multiple polymeric components. In preferred cases, the weight percentage of high-density polyethylene is greater than 80% by weight polymeric material. In some preferred cases, the weight percentage of high-density polyethylene is greater than 90% by weight polymeric material. In a particularly preferred  
10 case the polymeric material consists essentially of high density polyethylene, that is, the polymeric material includes no other polymer components other than high-density polyethylene, but may include other additives, as described further below, in addition to the nucleating agent.

Optionally, the foam composition may also include other additives, as known in the  
15 art, in addition to the nucleating agents. Such additives may be processing aids such as plasticizers (e.g. low-molecular weight organic compounds), lubricants, flow enhancers, and anti-oxidants. In many preferred cases, the polymeric material is essentially free of residual chemical blowing agents and reaction by products because only physical blowing agents are used in the process. In particular, many high-density polyethylene foams are essentially free  
20 of residual chemical blowing agents and reaction by-products.

Surprisingly, even though the amount of nucleating agent is greater than 2.5 weight percent, the foams have a relatively uniform and fine cell structure. The nucleating agents have not led to the presence of anomalous large cells in the foams. Foam articles, according to this aspect of the invention, have an average cell size of less than about 60 microns, or other  
25 preferred average cell sizes or maximum cell sizes, or combinations, described above.

The cell structure of the microcellular foam, preferably, is a closed cell structure. It is believed that the closed cell structure may, advantageously, contribute to enhancing the mechanical properties of the foam due to the absence of a long interconnected pathway which could act as a site that leads to premature failure of the material.

30 In accordance with this aspect of the invention, microcellular foams can be produced over a wide range of densities. In many embodiments, the void volume is greater than 10%, in other embodiments greater than 20%, and in still other embodiments greater than 50%. In

another set of embodiments, the microcellular foam has a void volume of less than 50%, and in some embodiments less than 30%. In a particularly preferred embodiment, the microcellular foam has a void volume between about 10% and about 50%. Foams within this preferred void volume range (10% to 50%) exhibit excellent mechanical properties such as  
5 tensile strength and tensile modulus, while still having a significant density reduction from the solid plastic.

An unlimited variety of semicrystalline microcellular foam articles are embraced by this aspect of the invention. Articles may be extruded, blow molded, injection molded into an unlimited number of shapes and forms. Extruded sheet can also be thermoformed. The  
10 foamed articles, in certain embodiments, are generally thinner than conventional foam articles because the cell sizes in the microcellular foam articles are smaller than the cell sizes in conventional foams. In certain cases, the articles have at least one portion having a thickness of less than 0.1 inches, in other cases less than 0.05 inch, and in other cases less than 0.01 inch. In many cases, the microcellular foam articles have a desirable surface quality because  
15 the articles can be produced with low blowing agent percentages, thus limiting the amount of gas that diffuses through the foam surface. As is known in the field of microcellular foam processing, large quantities of gas that diffuse through the surface can lead to surface roughness and imperfections, in some cases.

An extrusion system for the production of microcellular foam having a midlevel  
20 amount of nucleating agent can be similar to that illustrated in Fig. 1, with optional replacement of blow mold die 10 and blow mold apparatus 12 with an extrusion die for recovery of extrudate that is not significantly further processed, and/or a mold for injection molding.

As is well known in the art, in some cases, the nucleating agent may be added in a  
25 concentrate blend with the semicrystalline polymer in pellet form. That is, nucleating agent particles are dispersed in pellets of semicrystalline polymer in concentrated percentages, for example 40% by weight. The concentrated pellets are blended with suitable amounts of semicrystalline pellets to produce a polymeric material having between 2.5 and 7 weight percent nucleating agent. In this fashion, the percentage of talc in the polymeric material  
30 composition can be adjusted by controlling the ratio of concentrate to pure polymer pellets. In other embodiments, also well known to those skilled in the art, nucleating agents in particulate form may be added directly to the polymeric material. Any other techniques well known in

the art may also be employed for incorporating the nucleating agents into the polymer composition in controllable amounts.

Surprisingly, in some embodiments, it has been discovered that the present microcellular semicrystalline foam can be formed using relatively low blowing agent percentages. The presence of the nucleating agent is believed to enhance the driving force for nucleation thus enabling the production of microcellular foam at low blowing agent percentages, for example less than 1.5 percent blowing agent by weight of polymeric stream and blowing agent. In preferred embodiments, the process involves adding less than 1.0 weight percent blowing agent, and in other preferred cases, the process involves adding less than 0.1 percent, by weight of polymeric stream and blowing agent.

Referring now to Fig. 5, a preferred embodiment of the blowing agent port is illustrated in greater detail and, in addition, two ports on opposing top and bottom sides of the barrel are shown. In this preferred embodiment, port 154 is located in the gas injection section of the screw at a region upstream from mixing section 60 of screw 38 (including highly-broken flights) at a distance upstream of the mixing section of no more than about 4 full flights, preferably no more than about 2 full flights, or no more than 1 full flight. Positioned as such, injected blowing agent is very rapidly and evenly mixed into a fluid polymeric stream to promote production of a single-phase solution of the foamed material precursor and the blowing agent.

Port 154, in the preferred embodiment illustrated, is a multi-hole port including a plurality of orifices 164 connecting the blowing agent source with the extruder barrel. As shown, in preferred embodiments a plurality of ports 154 are provided about the extruder barrel at various positions radially and can be in alignment longitudinally with each other. For example, a plurality of ports 154 can be placed at the 12 o'clock, 3 o'clock, 6 o'clock, and 9 o'clock positions about the extruder barrel, each including multiple orifices 164. In this manner, where each orifice 164 is considered a blowing agent orifice, the invention includes extrusion apparatus having at least about 10, preferably at least about 40, more preferably at least about 100, more preferably at least about 300, more preferably at least about 500, and more preferably still at least about 700 blowing agent orifices in fluid communication with the extruder barrel, fluidly connecting the barrel with a source of blowing agent.

Also in preferred embodiments is an arrangement (as shown in Fig. 5) in which the blowing agent orifice or orifices are positioned along the extruder barrel at a location where,

when a preferred screw is mounted in the barrel, the orifice or orifices are adjacent full, unbroken flights 165. In this manner, as the screw rotates, each flight, passes, or “wipes” each orifice periodically. This wiping increases rapid mixing of blowing agent and fluid foamed material precursor by, in one embodiment, essentially rapidly opening and closing each orifice by periodically blocking each orifice, when the flight is large enough relative to the orifice to completely block the orifice when in alignment therewith. The result is a distribution of relatively finely-divided, isolated regions of blowing agent in the fluid polymeric material immediately upon injection and prior to any mixing. In this arrangement, at a standard screw revolution speed of about 30 rpm, each orifice is passed by a flight at a rate of at least about 0.5 passes per second, more preferably at least about 1 pass per second, more preferably at least about 1.5 passes per second, and more preferably still at least about 2 passes per second. In preferred embodiments, orifices 154 are positioned at a distance of from about 15 to about 30 barrel diameters from the beginning of the screw (at upstream end 34).

Referring again to Fig. 1, mixing section 60 of screw 38, following the gas injection section, is constructed to mix the blowing agent and polymer stream to promote formation of a single phase solution of blowing agent and polymer. The mixing section includes unbroken flights which break up the stream to encourage mixing. Downstream the mixing section, a metering section builds pressure in the polymer-blowing agent stream. Where a die is used that released shaped extrudate according to the die shape, the die includes inner passageways having shape and dimensions (die geometry) to control the shape of the extrudate. The die, in this embodiment, can have any of a variety of configurations, as is known in the art, to produce microcellular foam in specific forms, for example, sheets, profiles, or strands. Dies described in international patent publication no. WO 98/08667 incorporated herein by reference can be used. In addition to shaping extrudate released from such a die, the die can also perform the function of nucleating the single-phase solution of polymeric material and blowing agent. As described above with respect to Figs. 2-4, as the pressure in the single-phase solution drops as the solution flows through die internal passageways, solubility of the blowing agent in the polymer decreases, which is the driving force for cell nucleation. The extent of pressure drop depends upon the dimensions of the passageway. Specifically, the dimensions that effect pressure dropping include the shape of the passageway, the length of the passageway, and the thickness of the passageway. Under processing conditions, the pressure drop across the die is generally greater than 1,000 psi, preferably greater than 2,000



psi, and more preferably greater than 3,000 psi.

Dies of the invention can be also configured, as known in the art, to provide a pressure drop rate ( $dp/dt$ ) as the single-phase solution flows across the passageway. Pressure drop rate, which depends upon die geometry and flow rate, also effects the cell nucleation process.

5 Typically, a sufficient pressure drop rate must be induced to achieve appropriate nucleation conditions for microcellular material. The presence of the nucleating agent at an amount between 2.5-7% by weight is believed to lower the pressure drop rate required. In certain cases, it is desirable to use a process that employs low pressure drop rates. Lower pressure drop rates, generally, allow for more freedom in die construction and resulting article  
10 dimensions. In certain embodiments, the pressure drop rate in the solution is less than 1.0 GPa/s, in some embodiments less than 0.10 GPa/s, and, in some embodiments less than 0.05 GPa/s. In other embodiments, higher pressure drop rates are utilized, for example, in the production of certain thin products. In some cases, the pressure drop rate is greater than 1.0 GPa/s, in others greater than 5.0 GPa/s, and in others greater than 10.0 GPa/s.

15 In another embodiment, not illustrated, the pressure drop rate is induced in at least one nucleating pathway prior to or within the die. Such configurations are described in co-pending international patent publication no. WO 98/08667 published March 5, 1997 and incorporated herein by reference.

As a result of elevated temperatures, extrudate that is released from a die is typically  
20 soft enough so that the nucleated cells grow. As the extrudate cools in the atmosphere and becomes more solid, cell growth is restricted. In certain embodiments, it is advantageous to provide external cooling means to speed the cooling rate of the extrudate. For example, in these embodiments, cooling may be accomplished by blowing air on the extrudate, contacting the extrudate with a cool surface, or submerging the extrudate in a liquid medium. Other  
25 equipment (not illustrated) downstream of the die can be used, as required, for additional shaping of the extrudate into a final form.

Referring to Fig. 6, an alternative extrusion system 170 for producing microcellular foam in accordance with the invention includes a tandem extruder line. The tandem line includes a primary extruder 172 and a secondary extruder 174 arranged in parallel  
30 configuration and connected through a transfer pipe 176. As described above, pellets are supplied into the primary extruder through hopper 44. In some embodiments, the secondary extruder includes blowing agent injection port 54, as illustrated. In other embodiments, the

primary extruder includes the blowing agent injection port.

In other embodiments, the systems of Figs. 5 and 6 are modified, as known in the art, to function as injection molding systems. Particularly preferred injection molding systems are described in international patent publication no. WO 98/31521 which is incorporated by  
5 reference. Generally, injection molding systems do not include an extrusion die, but rather include a pathway fluidly connected to the polymer processing space through which the polymer and blowing agent solution is injected into the mold.

The invention provides, in another aspect, specific die designs that are useful for making high quality, microcellular, polymeric extrudate. Generally, the die is constructed to  
10 provide HDPE sheet or tubes of thin walls. More specifically, the die can be constructed to provide HDPE parisons for blow molding applications. In this aspect the invention involves the discovery that a specific range of taper angles of a converging nucleating microcellular polymeric die provides HDPE extrudate, including parisons for blow molding, that do not strip, or tear in the extrusion process and that include are more uniform in surface appearance.

15 Specifically, in this aspect a polymer forming die is provided that includes a nucleating pathway that decreases in cross section in a downstream direction with an included angle of greater than  $4^\circ$ . Preferably, the included angle is greater than  $6^\circ$ . In one embodiment the angle is between  $4^\circ$  and  $18^\circ$ , preferably between  $4^\circ$  and  $8^\circ$ . "Included angle", as used herein, means the total angle of downstream-direction taper. For example, in  
20 an annular die in which the exterior wall tapers inwardly at  $4^\circ$  and the interior wall, defined by the exterior of a mandral, has no taper, the included angle is  $4^\circ$ . In an identical situation in which the mandral tapers outwardly at  $2^\circ$ , the included angle would be  $6^\circ$ .

The taper angle of the die of the invention defines a particular time between initiation of nucleation in the die and release from the die exit, and this timing defines another aspect of  
25 the invention. Specifically, a method is provided that involves releasing a nucleated stream as a polymeric microcellular extrudate from an outlet of a die in a period of time of no more than about 0.001 second after nucleation, within the die, of a single-phase, non-nucleated solution of polymeric material and blowing agent.

The invention involves the discovery of a problem in the extrusion of HDPE sheet or  
30 thin profiles. It has been discovered that under microcellular extrusion conditions where a parallel type nucleator is used extrudate, especially HDPE parisons for blow molding, tend to strip during the extrusion process. Normal microcellular conditions, in these cases, are

described by using a nucleator that creates the necessary pressure drop rate required to form small cells and using typical conditions of blowing agent content and melt temperature.

Stripping is defined as a condition in which extrudate, upon exiting a die, tears at one or more locations along the length of the die. This tearing interferes with the formation of a uniform extrudate, resulting in the formation of long, thin strips of microcellular material. Each strip is the result of the complete severing of the extrusion at each of the locations of the observed tear. This phenomena has been observed in HDPE and has not been observed in other materials tested, including polypropylene, and is thought to be caused by the highly linear nature of the HDPE molecule and the ease with which the molecules slip past one another under low force.

The problem of HDPE stripping is alleviated according to the invention by using a tapered die (a die that decreases in cross section in a downstream direction) of a very specific included taper angle. The taper angle minimum is dictated by the ability to overcome this stripping problem and still provide a minimum pressure drop rate necessary to make microcellular material. Angles of less than about 4 degrees do not generate the required pressure drop rate for microcellular material at commercially reasonable rates and at acceptable total pressure drops. At angles of 6 degrees and greater, a sufficient pressure drop rate can be achieved and the stripping problem is completely overcome. A maximum angle exists that still makes an acceptable structure. At angles greater than about 18 degrees, the microcellular structure tends to blow itself apart, resulting in very poor cell structures for blow molding purposes.

The result of stripping prevention was unexpected. Although not wishing to be bound by any theory, it is believed that the tapered die works because there is a critical location where the beginning of nucleation occurs. This location is defined by the point at which the pressure in the polymer/blowing agent melt (single-phase, non-nucleated solution of polymeric material and blowing agent) is reduced below the saturation pressure of the blowing agent in the polymer. If this location is too far away from the exit of the die (measured not by distance, but by residence time or the time it takes the nucleated polymer to travel from the initial nucleation point to the end of the die where release of polymer extrudate occurs), then stripping occurs when shear forces on the growing cell acts for too long a time resulting in tearing of the melt. If the location is closer to the exit than this critical point, then the foaming melt does not undergo enough shear to cause tearing. In parallel nucleators,

where pressure drop rate is constant throughout the nucleation land length and pressure decreases linearly throughout the nucleator, the point of nucleation occurs too far from the exit of the die. In tapered dies, where pressure drop rate increases throughout the nucleator and pressure decreases mostly near the die exit, the point of nucleation is very close to the die exit. The result is that shearing acts over only a short period of time and no stripping occurs. The proposed theory compels selection of a specific taper angle that both eliminates stripping and allows for the standard conditions of pressure drop rate to be met.

Microcellular material produced according to the invention can be used in blow molding processes, for example in production of blow molded bottles. Additionally, sheets of microcellular polymeric material, including microcellular HDPE, either in flat die or annular die designs, can be made. Material made with systems of the invention also can be thermoformed. In one embodiment, the die of the invention provides the ability to change parison thickness by movement of the inner pin of the die with respect to the outer die body.

In addition to die angle and gap opening, the specific dies can also be described by the pressure and pressure drop rate needed to make defect free, microcellular parisons.

In one set of embodiments, foam articles that consist essentially of high-density polyethylene (HDPE), are formed without the use of a chemical blowing agent. High-density polyethylene, as used herein, refers to polyethylene having a density of greater than 0.94 g/cm<sup>3</sup>. Low-density polyethylene refers to polyethylene having a density of less than 0.94 g/cm<sup>3</sup>. In such articles, HDPE is essentially the only polymeric component but the article includes any variety of additives as known in the art, such as a nucleating agent. Such articles thus, are essentially free of residual chemical blowing agent and reaction-by-products of chemical blowing agent. In some embodiments of this set, the HDPE foam articles are microcellular foams having average cell sizes of less than 100 microns. In certain cases, the microcellular foams have average cell sizes of less than 50 microns, and in some cases less than 20 microns. In other embodiments of this set, the HDPE foams are conventional foams having average cell sizes of greater than 100 microns. The articles can be produced over a broad range of densities. In certain embodiments, the void volume is greater than 10%, in some embodiments greater than 20%, in other embodiments greater than 50%. In a preferred set of embodiments, the article has a void volume of between 10% and 40%.

The process of forming the high-density polyethylene foam articles employs the use of a physical blowing agent, as described above. In this set of embodiments, HDPE foam

articles are produced that have a shape essentially identical to that of a continuous extrudate, or a shape essentially identical to that of the interior of a mold. That is, the foam articles are produced by continuous extrusion, or molding, including blow-molding. Although some cell growth can occur following extrusion, or following molding, the articles retain shapes that are

5 closely reminiscent of the extrudate or of the mold. This is to distinguish articles that are extruded or molded in an un-foamed state, and then later foamed by, for example, saturation with blowing agent and expansion, as occurs in typical prior art batch processes.

The function and advantage of these and other embodiments of the present invention will be more fully understood from the examples below. The following examples are

10 intended to illustrate the benefits of the present invention, but do not exemplify the full scope of the invention.

#### Example 1 - System for Blow Molding

A tandem extrusion line including a 2 ½ mm 32:1 L/D single screw primary extruder

15 (Akron Extruders, Canal Fulton, OH) and a 3 36:1 L/D single screw secondary extruder (Akron Extruders, Canal Fulton, OH) was arranged in a right angle configuration. A volumetric feeder capable of supplying up to 30 lb/hr was mounted in the feed throat of the primary extruder such that compounded talc additive pellets could be metered into the primary extruder. An injection system for the injection of CO<sub>2</sub> into the secondary was placed at

20 approximately 8 diameters from the inlet to the secondary. The injection system included 4 equally spaced circumferential, radially- positioned ports, each port including 176 orifices, each orifice of 0.02 inch diameter, for a total of 704 orifices. The injection system included an air actuated control valve to precisely meter a mass flow rate of blowing agent at rates from 0.2 to 12 lbs/hr at pressures up to 5500 psi.

25 The screw of the primary extruder was specially designed screw to provide feeding, melting and mixing of the polymer/talc concentrate followed by a mixing section for the dispersion of blowing agent in the polymer. The outlet of this primary extruder was connected to the inlet of the secondary extruder using a transfer pipe of about 24 inches in length.

30 The secondary extruder was equipped with specially designed deep channel, multi-flighted screw design to cool the polymer and maintain the pressure profile of the microcellular material precursor, between injection of blowing agent and entrance to a gear

pump (LCI Corporation, Charlotte, NC) attached to the exit of the secondary. The gear pump was equipped with an integral jacket for heating/cooling and sized to operate at a maximum output of 250 lb/hr with a rated maximum discharge pressure of 10,000 psi.

The system was equipped, at exit from the gear pump, with a die adapter and a  
5 vertically mounted blow molding die (Magic Company, Monza, Italy). The die adapter was equipped with taps for measurement of melt temperature and pressure just prior to entry into the die. The blow molding head included a conventional spider type flow distribution channel and a die adjustment system that allowed movement of the die relative to the fixed position tip providing a variety of exit gaps depending on the chosen tooling.

10 A two-piece bottle mold was mounted in a fixture for the hand molding of sample bottles as a secondary process. One half of the mold was mounted stationary in the fixture with the other half mounted on linear slides. Quick acting clamps mounted on the stationary half of the mold provided the mechanism to clap the mold shut. A short section of steel tubing sharpened to a point attached to a 0 - 50 psi regulator using a length of flexible hose  
15 provided the blow system. Mold diameter varied from approximately 1 inch in the cap area to 2 to 3 inches in the body of the bottle. The overall cavity length of the bottle mold was approximately 10 inches.

#### Example 2: Parison and bottle formation

20 High density polyethylene (Equistar LR 5403) pellets were introduced into the main hopper of extrusion line described in example 1 and a precompounded talc concentrate (50% talc in a HDPE base) was introduced in the additive feeder hopper. The tooling attached to the blow molding head included a die with a 0.663 inch exit diameter and 6.2° taper angle and a tip of 0.633 inch exit diameter and 2° taper angle. The combination of this tip and die  
25 provides an 8.2° included convergence angle.

The extruder and gear pump rpm were adjusted to provide an output of approximately 210 lb/hr at speeds of approximately 78 rpm on the primary, 32 rpm on the secondary and 50 rpm of the gear pump. Secondary barrel temperatures were set to maintain a melt temperature of approximately 315° F at entrance to the die. The additive feeder was set to provide an  
30 output of approximately 11 lb/hr resulting in a 2.7 % by polymer weight talc in the material. CO<sub>2</sub> blowing agent was injected at a nominal rate of 3.3 lb/hr resulting in a 1.6% by polymer weight blowing agent in the material.

The above conditions produced a parison that was 0.045 inch thick by approximately 1.3 inches in diameter at a density of 0.74 gm/cc. Based on a nominal solid material density of 0.95 gm/cc, the achieved density reduction is 23 %.

Sample bottles were produced in the following manner: A parison of approximately 5 16 inches in length was extruded, manually removed from the extruder and immediately positioned in the mold. The mold halves were quickly closed and clamped. With the air regulator set to 20 psi, the sharpened tube was then used to pierce the parison at the top of the mold and introduce the air into the ID of the parison now closed at end of the mold.

The above conditions produced a bottle of 0.015 inch thick by approximately 2.5 10 inches in diameter at a density of 0.70 gm/cc.

### Example 3: Parison and bottle formation

High density polyethylene (Equistar LR 5403) pellets were introduced into the main hopper of an extrusion line described in example 1 and a precompounded talc concentrate 15 (50% talc in a HDPE base) was introduced in the additive feeder hopper. The tooling attached to the blow molding head included a die with a 0.675 exit diameter and 4.0° taper angle and a tip of 0.633 exit diameter and 2° taper angle. The combination of this tip and die provided a 6.0° included convergence angle.

The extruder and gear pump rpm were adjusted to provide an output of approximately 20 180 lb/hr at speeds of approximately 66 rpm on the primary, 30 rpm on the secondary and 40 rpm of the gear pump. Secondary barrel temperatures were set to maintain a melt temperature of approximately 310 °F at entrance to the die. The additive feeder was set to provide an output of approximately 18 lb/hr resulting in a 5.3 % by polymer weight talc in the material. N<sub>2</sub> blowing agent was injected at a nominal rate of 0.6 lb/hr resulting in a 0.33% by polymer 25 weight blowing agent in the material.

The above conditions produced a parison that was 0.080 inch thick by approximately 1.2 inches in diameter at a density of 0.69 gm/cc. Based on a nominal solid material density of 0.95 gm/cc, the achieved density reduction is 29 %.

Sample bottles were produced in the following manner: A parison of approximately 30 16 inches in length was extruded, manually removed from the extruder and immediately positioned in the mold. The mold halves were quickly closed and clamped. With the air regulator set to 40 psi, the sharpened tube was then used to pierce the parison at the top of the

mold and introduce the air into the ID of the parison now closed at end of the mold.

The above conditions produced a bottle of 0.037 inch thick by approximately 2.0 inches in diameter at a density of 0.79 gm/cc.

5 Example 4. Extrusion of Microcellular Polypropylene Material Without Filler

A tandem extrusion line (Akron Extruders, Canal Fulton, OH) was arranged including a 2.5 inch, 32/1 L/D primary extruder and a 3.0 inch, 34/1 L/D secondary extruder. An injection system for injection of CO<sub>2</sub> into the primary was placed at a distance of approximately 20 diameters from the feed section. The injection system included 4 equally-  
10 spaced circumferentially, radially-positioned ports, each port including 176 orifices, each orifice of 0.02 inch diameter, for a total of 704 orifices.

The primary extruder was equipped with a two-stage screw including conventional first-stage feed, transition, and metering sections, followed by a multi-flighted (four flights) mixing section for blowing agent dispersion. The screw was designed for high-pressure  
15 injection of blowing agent with minimized pressure drop between the first-stage metering section and point of blowing agent injection. The mixing section included 4 flights unbroken at the injection ports so that the orifices were wiped (opened and closed) by the flights. At a screw speed of 80 RPM each orifice was wiped by a flight at a frequency of 5.3 wipes per second. The mixing section and injection system allowed for very rapid establishment of a  
20 single-phase solution of blowing agent and polymeric material.

The injection system included air-actuated control valve to precisely meter a mass flow rate of blowing agent at rates from 0.2 to 12 lbs/hr at pressures up to 5500 psi.

The secondary extruder was equipped with a deep channel, three-flighted cooling screw with broken flights, which provided the ability to maintain a pressure profile of  
25 microcellular material precursor, between injection of blowing agent and entrance to the point of nucleation (the die, in this case) varying by no more than about 1500 psi, and in most cases considerably less.

The system included instrumentation allowing measurement of pressure and temperature of the melt stream at least six locations throughout the tandem system between a  
30 location just prior to the blowing agent injection ports to the point of entry into the die to precisely monitor material conditions. Along the screw, melt temperature was measured with infrared equipment to avoid disruption of the melt stream.



Polypropylene pellets were gravity-fed from a hopper into the extrusion system. The grade used was a standard homopolymer resin, Montell's 6823, having a nominal melt flow index of 0.5 g/ 10 min. The polymeric material was essentially free of nucleating agent. Primary screw speed was 90 RPM, giving a total output of approximately 84 lbs/hr of material. Secondary screw speed was 5 RPM. Barrel temperatures of the secondary extruder were set to maintain a melt temperature of 386 deg. F measured at the end of the secondary extruder. CO<sub>2</sub> blowing agent was injected at a rate of 4.0 lbs/hr resulting in 4.8% blowing agent in the melt. A die adapter at the discharge of the secondary extruder was connected to a flat sheet T-type die having a die exit of 4.5 inches width and gap of 0.034 inch. A separate nucleator of constantly decreasing gap to an exit dimension of 0.015 inch was positioned within 0.5 inches of the die exit. The die had both melt and pressure indicators. Pressure profile between the injection ports and the inlet of the die was maintained between 2120 and 3490 psi.

Fig. 7 is a photocopy of an SEM image of the cross section of the sheet showing a uniform dispersion of cells having an average diameter of about 25 microns. The sheet had an approximate thickness of 0.033 inch (0.83 mm). The density of the microcellular foam was approximately 0.63 g/cm<sup>3</sup> (39 lbs/ft<sup>3</sup>).

#### Example 5. Extrusion of Microcellular Polypropylene Sheet Without Filler

The same extrusion system, die, and polypropylene grade as described above in Example 4 was used for this example. The polymeric material was essentially free of nucleating agent. Primary screw speed was 75 RPM, giving a total output of approximately 60 lbs/hr of material. Secondary screw speed was 20 RPM. Barrel temperatures of the secondary extruder were set to maintain a melt temperature of 358 deg. F measured at the end of the secondary extruder. CO<sub>2</sub> blowing agent was injected at a rate of 2.5 lbs/hr resulting in 4.2% blowing agent in the melt. Pressure profile between the injection ports and the inlet of the die was maintained between 2180 psi and 3650 psi.

The sheet was taken up using a standard three roll stack, maintained at a temperature of 100 deg. F using circulating oil. The take up speed was about 30 ft/min, to give a final sheet thickness of approximately 0.036 inch (0.93 mm). Fig. 8 is a photocopy of an SEM image of the cross section of the sheet, showing a non-uniform, generally non-microcellular structure. The average cell size was about 65 microns, with maximum size of 120 microns

diameter. Material density was measured to be 0.79 g/cm<sup>3</sup> (49.3 lbs/ft<sup>3</sup>).

The larger average cell size of the sheet produced in Example 5 compared to the sheet produced in Example 4 is due, in large part, to the lower blowing agent concentration used in Example 5 without the use of a nucleating agent.

5

#### Example 6. Extrusion of Microcellular Polypropylene Sheet Having Talc Filler

Using the same polypropylene material and extrusion system as described in Example 4, polypropylene pellets were gravity-fed from a hopper into the extrusion system. Primary screw speed was 48 RPM, giving a total output of approximately 100 lbs/hr of material. Secondary screw speed was 16 RPM. An auger type feeder was used to feed a talc/PP pellet concentrate (EP5140 A1 from Spartech Polycom) into the hopper. The screw speed on the auger was set to deliver 12.5 lb/hr of talc concentrate into the hopper. This rate corresponded to 12.5% by weight based on the total material output. Since this concentrate was 40% by weight of talc, the resultant formulation contained about 5% talc. Barrel temperatures of the secondary extruder were set to maintain a melt temperature of 424 deg. F measured at the end of the secondary extruder. CO<sub>2</sub> blowing agent was injected at a rate of 0.5 lbs/hr resulting in 0.5% blowing agent in the melt. Pressure profile between the injection ports and the inlet of the die was maintained between 1580 psi and 1900 psi. The die placed at the end of the secondary extruder was a t-type flat die having an opening of 11 inches in width by 0.030 inch gap. The die lips were parallel, having a 0.5 inch final land length. The pressure drop rate across the die lips was 0.07 GPa/s.

Using the same three roll stack maintained at 100°F, the sheet was taken up at 11.4 ft/min, resulting in a sheet thickness of 0.038 inch (0.97 mm). Fig. 9 is a photocopy of an SEM image of the cross section of the sheet, showing fairly uniform, primarily closed cells of an average of about 50 microns diameter. The resultant sheet density was 0.71 g/cc (44.3 lbs/ft<sup>3</sup>).

Example 6 illustrates the production of microcellular polypropylene, including a mid-level range of talc as a nucleating agent, using a relatively low gas percentage and a relatively low pressure drop rate.

30

#### Example 7. Extrusion of Microcellular Polypropylene Sheet Having Talc and Titanium Dioxide Fillers

The system identical to that described in Example 6 was used, except that a titanium dioxide/PP concentrate was hand mixed with the talc concentrate in a ratio of four parts talc concentrate to one part titanium dioxide (TiO<sub>2</sub>) concentrate. Since the titanium dioxide concentrate also had about 40% by weight of TiO<sub>2</sub>, this filler consisted of approximately 80% talc and 20% TiO<sub>2</sub>. Primary screw speed was 48 RPM, giving a total output of approximately 100 lbs/hr of material. The blend of concentrate pellets was fed by the auger feeder at a rate of 12.5 lb/hr, resulting in a final formulation containing 5% nucleating agent in the polypropylene matrix. Barrel temperatures of the secondary extruder were set to maintain a melt temperature of 424° F measured at the end of the secondary extruder. CO<sub>2</sub> blowing agent was injected at a rate of 0.6 lbs/hr resulting in 0.6% blowing agent in the melt. Pressure profile between the injection ports and the inlet of the die was maintained between 1550 psi and 1900 psi. The die placed at the end of the secondary extruder was identical in all respects to that described in Example 6. The pressure drop rate across the die lips was about 0.07 GPa/s.

Using the same three roll stack, a take up speed of 11.7 ft/min resulted in a sheet thickness of 0.040 inch (1.0 mm) and had a density of 0.73 g/cc (45.6 lbs/ft<sup>3</sup>). Fig. 10 is a photocopy of an SEM image of the cross section of the sheet, showing fairly uniform, primarily closed cells of an average of about 40 microns diameter.

Example 7 illustrates the production of microcellular polypropylene, including talc and TiO<sub>2</sub> as nucleating agents.

#### Example 8. Microcellular Polypropylene 5% Talc Filled Tubular Product

An NRM (Pawcatuck, CT) 2.5 inch 44/1 L/D long single extrusion line was equipped with an injection system for injection of CO<sub>2</sub> placed at a distance of approximately 25 diameters from the feed section. The injection system included 4 equally-spaced circumferentially, radially-positioned ports, each port including 417 orifices, each orifice of 0.02 inch diameter, for a total of 1668 orifices.

The extruder was equipped with a two-stage screw including conventional first-stage feed, barrier flight transition, and metering sections, followed by a multi-flighted (six flights) mixing section for blowing agent dispersion. The screw was designed for high-pressure injection of blowing agent with minimized pressure drop between the first-stage metering section and point of blowing agent injection. The second stage of the screw included a mixing

section having 6 flights unbroken at the injection ports so that the orifices were wiped (opened and closed) by the flights. At a screw speed of 80 RPM each orifice was wiped by a flight at a frequency of 8 wipes per second. The mixing section and injection system allowed for very rapid establishment of a single-phase solution of blowing agent and polymeric material. The injection system included an air-actuated control valve to precisely meter a mass flow rate of blowing agent at rates from 0.2 to 50 lbs/hr at pressures up to 5500 psi.

The second stage of the screw was also equipped with a deep channel, three-flighted cooling section with broken flights, which provided the ability to cool the polymer melt stream.

The system included, at the end of the extruder, a die adapter and a cylindrical annular die with a gap of 0.34 inch, inner diameter of 0.4 inch, and land length of 2 inches. The die adapter was equipped with taps for measurement of melt temperature and pressure just prior to entry into the die.

The system included instrumentation allowing measurement of pressure and temperature of the melt stream at least 7 locations throughout the system between a location just prior to the blowing agent injection ports to the point of entry into the die to precisely monitor material conditions. Along the screw, melt temperature was measured with infrared equipment to avoid disruption of the melt stream.

A standard homopolymer resin, Solvay's HB 1301, having a nominal melt flow index of 5g/10 min., was used as the base resin. Talc concentrate consisting of pellets having 40 percent by weight of talc dispersed in a homopolymer polypropylene matrix (Montell Astryn 65F4-4) were blended with the HB 1301 using a loss-in-weight type blending system to produce a mixture containing 5% by weight of talc (12.5% talc concentrate). This mixture was then gravity fed from a hopper into the extrusion system. Primary screw speed was 50 RPM, giving a total output of approximately 54 lbs/hr of material. Barrel temperatures were set to maintain a melt temperature of 422 deg. F measured at the end of the extruder. CO<sub>2</sub> blowing agent was injected at a rate of 0.3 lbs/hr resulting in 0.55% blowing agent in the melt. A die adapter was attached to the discharge of the extruder, connecting to a cylindrical annular die having a gap of 0.025 inches with an outer diameter of 0.18 inches and a land length of 0.15 inches. Pressure profile between the injection ports and the inlet of the die was maintained between 2430 and 3540 psi. The pressure drop rate across the die was 11.2 GPa/s.

Fig. 11 is a photocopy of an SEM image of the cross section of the extrudate, showing generally spherical cells approximately 50 microns in diameter dispersed throughout the cross section of the tube wall. Wall thickness of the product was approximately 0.008 inch (0.21 mm). Product outer diameter was about 0.26 inch (6.60 mm). Material density was  
5 approximately 0.51 g/cm<sup>3</sup> (32 lbs/ft<sup>3</sup>).

Example 8 illustrates the production of thin microcellular polypropylene material using a mid-level amount of talc as a nucleating agent, while utilizing a relatively low amount of blowing agent and a relatively high pressure drop rate.

#### 10 Example 9. Microcellular Polypropylene 3% Talc Filled Tubular Product

A resin formulation having the same base polypropylene resin grade as Example 8, but with 3% of talc (7.5% talc concentrate) was blended and gravity fed from a hopper into the extrusion system. Primary screw speed was 50 RPM, giving a total output of approximately 54 lbs/hr of material. Barrel temperatures were set to maintain a melt temperature of 427°F  
15 measured at the end of the extruder. CO<sub>2</sub> blowing agent was injected at a rate of 0.27 lbs/hr resulting in 0.5% blowing agent in the melt. A die as described in Example 8 was attached to the discharge of the extruder. Pressure profile between the injection ports and the inlet of the die was maintained between 2650 and 3900 psi. The pressure drop rate across the die was 12.4 GPa/s.

20 Fig. 12 is a photocopy of an SEM image of the cross section of the extrudate, showing generally spherical cells approximately 60 microns in diameter dispersed throughout the cross section of the tube wall. Wall thickness of the product was approximately 0.010 inch (0.25 mm). Product outer diameter was about 0.26 inch ( 6.60 mm). Material density was approximately 0.52 g/cm<sup>3</sup> (32.4 lbs/ft<sup>3</sup>).

25 The material produced in Example 9 has a larger average cell size compared to the material produced in Example 5 due to the presence of less nucleating agent in Example 6.

#### Example 10. Non-Microcellular Polypropylene 1% Talc Filled Tubular Product

A resin formulation having the same base polypropylene resin grade as Example 8, but  
30 with 1% of talc (2.5% talc concentrate) was blended and gravity fed from a hopper into the extrusion system. Primary screw speed was 50 RPM, giving a total output of approximately 54 lbs/hr of material. Barrel temperatures were set to maintain a melt temperature of 428°F

measured at the end of the extruder. CO<sub>2</sub> blowing agent was injected at a rate of 0.48 lbs/hr resulting in 0.9% blowing agent in the melt. A die as described in Example 8 was attached to the discharge of the extruder. Pressure profile between the injection ports and the inlet of the die was maintained between 2600 and 3880 psi. The pressure drop rate across the die was  
5 about 12.4 GPa/s.

Fig. 13 is a photocopy of an SEM image of the cross section of the extrudate, showing generally spherical cells approximately 150 microns in diameter dispersed throughout the cross section of the tube wall. Wall thickness of the product was approximately 0.018 inch (0.46 mm). Product outer diameter was about 0.26 inch (6.60 mm). Material density was  
10 approximately 0.53 g/cm<sup>3</sup> (33.1 lbs/ft<sup>3</sup>).

The material produced in Example 10 with less than a mid-level range of nucleating agent (1% talc) is non-microcellular.

#### Examples 11-14 High-Density Polyethylene Microcellular Foam

15 A tandem extrusion line including a 2 1/2 mm 32:1 L/D single screw primary extruder (Akron Extruders, Canal Fulton, OH) and a 3 36:1 L/D single screw secondary extruder (Akron Extruders, Canal Fulton, OH) was arranged in a right angle configuration. A volumetric feeder capable of supplying up to 30 lb/hr was mounted in the feed throat of the primary extruder such that compounded talc additive pellets could be metered into the primary  
20 extruder. An injection system for the injection of CO<sub>2</sub> into the secondary was placed at approximately 8 diameters from the inlet to the secondary. The injection system included 4 equally spaced circumferential, radially-positioned ports, each port including 176 orifices, each orifice of 0.02 inch diameter, for a total of 704 orifices. The injection system included an air actuated control valve to precisely meter a mass flow rate of blowing agent at rates from  
25 0.2 to 12 lbs/hr at pressures up to 5500 psi.

The screw of the primary extruder was specially designed screw to provide feeding, melting and mixing of the polymer/talc concentrate followed by a mixing section for the dispersion of blowing agent in the polymer. The outlet of this primary extruder was connected to the inlet of the secondary extruder using a transfer pipe of about 24 inches in  
30 length.

The secondary extruder was equipped with specially designed deep channel, multi-flighted screw design to cool the polymer and maintain the pressure profile of the

microcellular material precursor, between injection of blowing agent and entrance to a gear pump (LCI Corporation, Charlotte, NC) attached to the exit of the secondary. The gear pump was equipped with an integral jacket for heating/cooling and sized to operate at a maximum output of 250 lb/hr with a rated maximum discharge pressure of 10,000 psi.

5 The system was equipped, at exit from the gear pump, with a die adapter and a vertically mounted blow molding die (Magic Company, Monza, Italy). The die adapter was equipped with taps for measurement of melt temperature and pressure just prior to entry into the die. The blow molding head included a conventional spider type flow distribution channel and a die adjustment system that allowed movement of the die relative to the fixed position tip  
10 providing a variety of exit gaps depending on the chosen tooling.

The above described system was used to produce microcellular HDPE foam samples including a mid-level range of nucleating agent as illustrated in Examples 11-14. The processing conditions and the resulting product characteristics for Examples 11-14 are summarized as follows:

	<u>Example 11</u>	<u>Example 12</u>	<u>Example 13</u>	<u>Example 14</u>
15 Talc %	2.5	6.5	2.5	5.0
Gas Type	CO <sub>2</sub>	CO <sub>2</sub>	N <sub>2</sub>	N <sub>2</sub>
Gas %	1.3	1.3	0.33	0.33
Melt Temp (OF)	311	311	318	318
20 Output (lb/hr)	120	120	217	218
dP/dt (GPa/s)	3.9	3.9	3.5	3.5
Cell Size (μm)	53	29	50	34

#### 25 Example 15: Microcellular Extrusion System

A tandem extrusion line as described in Example 1 was used with the exception that the secondary extruder was equipped with a deep channel, multi-flighted screw design to cool the polymer and maintain the pressure profile of the microcellular material precursor, between injection of blowing agent and entrance to a die adapter and a vertically mounted blow  
30 molding die (Magic Company, Monza, Italy). The die adapter was equipped with taps for measurement of melt temperature and pressure just prior to entry into the die. The blow molding head included a conventional spider type flow distribution channel and a die adjustment system that allowed movement of the die relative to the fixed position tip providing a variety of exit gaps depending on the chosen tooling.

Example 16: Comparative; Stripped Parison formation

High density polyethylene (Equistar LR 5403) pellets were introduced into the main hopper of the extrusion line described in example 15. The tooling attached to the blow molding head included a die with a 1.227 exit diameter and a tip of 1.181 exit diameter and 2° taper angle. This tooling configuration provided an exit gap of 0.023 inches and an included taper angle of 2°.

The extruder was adjusted to provide an output of approximately 140 lb/hr at speeds of approximately 58 rpm on the primary and 25 rpm on the secondary. Secondary barrel temperatures were set to maintain a melt temperature of approximately 305°F at entrance to the die. The volumetric feeder was turned off and no compounded talc was added. CO<sub>2</sub> blowing agent was injected at a nominal rate of 4.8 lb/hr resulting in a 3.4% by polymer weight blowing agent in the material.

At the above conditions, the time to die exit from the point of nucleation of the polymer was approximately 0.060 seconds. These conditions produced stripping of the product.

Example 17: Miscellaneous Extrusion System

A system as in Example 15 was employed except that a gear pump (LCI Corporation, Charlotte, NC) was installed between the exit of the secondary and entrance to the head. The gear pump was equipped with an integral jacket for heating/cooling and sized to operate at a maximum output of 250 lb/hr with a rated maximum discharge pressure of 10,000 psi.

Example 18: Parison formation

High density polyethylene (Equistar LR 5403) pellets were introduced into the main hopper of the extrusion line described in example 17. The tooling attached to the blow molding head included a die with a 0.685 exit diameter and a tip of 0.623 exit diameter and 2° taper angle. This tooling configuration provided an exit gap of 0.031 inches and an included taper angle of 4°.

The extruder and gear pump rpm were adjusted to provide an output of approximately 216 lb/hr at speeds of approximately 78 rpm on the primary, 32 rpm on the secondary and 50 rpm on the gear pump. Secondary barrel temperatures were set to maintain a melt temperature of approximately 315°F at entrance to the die. The additive feeder was set to provide an



output of approximately 11 lb/hr resulting in a 2.7% by polymer weight talc in the material. CO<sub>2</sub> blowing agent was injected at a nominal rate of 2.2 lb/hr resulting in a 1.0% by polymer weight blowing agent in the material.

At the above conditions, the time to die exit from the point of nucleation of the polymer was approximately 0.002 seconds. These conditions produced good foam with an average cell size of approximately 70 microns without stripping.

#### Example 19: Parison formation

High density polyethylene (Equistar LR 5403) pellets were introduced into the main hopper of the extrusion line described in example 17. The tooling attached to the blow molding head included a die with a 0.661 exit diameter and of 4° taper angle and a tip of 0.633 exit diameter and 2° taper angle. This tooling configuration provided an exit gap of 0.014 inches and an included taper angle of 6°.

The extruder and gear pump rpm were adjusted to provide an output of approximately 212 lb/hr at speeds of approximately 62 rpm on the primary, 37 rpm on the secondary and 50 rpm on the gear pump. Secondary barrel temperatures were set to maintain a melt temperature of approximately 315°F at entrance to the die. The additive feeder was set to provide an output of approximately 11 lb/hr resulting in a 2.7% by polymer weight talc in the material. CO<sub>2</sub> blowing agent was injected at a nominal rate of 3.2 lb/hr resulting in a 1.5% by polymer weight blowing agent in the material.

At the above conditions, the time to die exit from the point of nucleation of the polymer was approximately 0.003 seconds. These conditions produced good foam with an average cell size of approximately 19 microns without stripping.

Those skilled in the art would readily appreciate that all parameters listed herein are meant to be exemplary and that actual parameters will depend upon the specific application for which the methods and apparatus of the present invention are used. It is, therefore, to be understood that the foregoing embodiments are presented by way of example only and that, within the scope of the appended claims and equivalents thereto, the invention may be practiced otherwise than as specifically described.

What is claimed is:

CLAIMS

1. An article comprising:  
a blow molded, foam, microcellular, polymeric article.  
5
2. An article comprising:  
an extruded, microcellular parison suitable for blow molding.
3. A polymeric article comprising:  
10 a matrix of polymeric material including a plurality of cells having an average cell size of less than 60 microns,  
the polymeric material comprising a semi-crystalline polymer, and a nucleating agent in an amount between about 2.5 and about 7 weight percent, by weight of the polymeric material.  
15
4. A foam article comprising:  
a matrix of polymeric material including a plurality of cells, the polymeric material consisting essentially of high-density polyethylene and being essentially free of residual chemical blowing agent and reaction-by-products of chemical blowing agent and having a  
20 shape essentially identical to that of a continuous extrudate.
5. A foam article comprising:  
a matrix of polymeric material including a plurality of cells, the polymeric material consisting essentially of high-density polyethylene and being essentially free of residual  
25 chemical blowing agent and reaction-by-products of chemical blowing agent and having a shape essentially identical to that of the interior of a mold.
6. An article as in any preceding claim, comprising polymeric semi-crystalline material and including nucleating agent in an amount of from about 2.5% to about 7% by weight, by  
30 weight of the polymeric material.
7. An article as in any preceding claim, having the appearance of an essentially solid,

white plastic article.

8. An article as in any of claims 1, 3, and 5-7, constructed as a container for food.
- 5 9. An article as in any of claims 1, 3, and 5-8, constructed as a container for milk.
10. An article as in any of claims 1, 3, and 5-9, containing food.
11. An article as in any of claims 1, 3, and 5-10, containing milk.
- 10 12. A polymeric article as in any preceding claim wherein the polymer matrix comprises between about 5 weight percent and about 7 weight percent of nucleating agent, by weight of the polymeric material.
- 15 13. An article as in any preceding claim, including residual chemical blowing agent or reaction by-product of chemical blowing agent in an amount less than that inherently found in articles blown with about 0.1% by weight chemical blowing agent or more.
14. An article as in any preceding claim, including residual chemical blowing agent or  
20 reaction by-product of chemical blowing agent in an amount less than that inherently found in articles blown with 0.05% by weight chemical blowing agent or more.
15. An article as in any preceding claim, being essentially free of residual chemical blowing agent or reaction by-product of chemical blowing agent.
- 25 16. An article as in any preceding claim, having less than about 0.1 percent by weight auxiliary chromophore, constructed and arranged for containing material subject to destruction upon exposure to light.
- 30 17. An article as in any preceding claim, the article being free of a non-foam, structurally-supporting material positioned to support the foam article.

18. An article as in any preceding claim, comprising at least two blow-molded, foam, microcellular polymeric layers.
19. An article as in claim 18, comprising at least two co-extruded layers.
- 5 20. An article as in any preceding claim, comprising an auxiliary non-foam, non-structurally-supporting layer adjacent the foam article.
- 10 21. An article as in any preceding claim, including at least one portion having a wall thickness of less than about 0.075 inch.
22. An article as in any of claims 1, 3, and 5-21, wherein the article is a container and at least 50% of the container has a wall thickness of less than about 0.075 inch.
- 15 23. An article as in claim 22, wherein the article is a container and at least 50% of the container has a wall thickness of less than about 0.050 inch.
24. An article as in claim 22, wherein the article is a container and at least 50% of the container has a wall thickness of less than about 0.040 inch.
- 20 25. An article as in any preceding claim, formed of polymeric material having melt flow of no more than about 0.2 g/10 min.
26. An article as in any of claims 1, 3, and 5-25, wherein the article is blow molded and includes a first portion expanded to a first extent and a second portion expanded at least 1.5 times the first extent, the first and second portions differing in each of thickness, material density, and cellular density by no more than about 5%.
- 25 27. An article as in any preceding claim, including less than about 10 percent by weight reinforcing agent.
- 30 28. An article as in any preceding claim, having an average cell size of less than about 100

microns.

29. An article as in any preceding claim, having an average cell size of less than about 50 microns.

5

30. An article as in claim 1, having an average cell size of less than about 30 microns.

31. An article as in any preceding claim, having a maximum cell size of about 75 microns.

10 32. An article as in any preceding claim, having a maximum cell size of about 50 microns.

33. An article as in any preceding claim, having a maximum cell size of about 35 microns.

15 34. An article as in any preceding claim, having an average cell size of less than about 30 microns and a maximum cell size of about 75 microns.

35. An article as in any preceding claim, having an average cell size of less than about 20 microns and a maximum cell size of about 50 microns.

20 36. An article as in any preceding claim, having an average cell size of less than about 10 microns and a maximum cell size of about 25 microns.

37. An article as in any preceding claim wherein the cells are primarily closed cells.

25 38. An article as in any preceding claim, including at least about 1% by weight nucleating agent.

39. An article as in claim 38, wherein the nucleating agent is talc.

30 40. An article as in any of claims 2-4 and 6-39, formed as an extruded parison suitable for blow molding, having a first portion and a second portion spaced from the first portion in a parison machine direction, the first portion and second portion differing in thickness by a

factor of at least about 1.1.

41. An article as in claim 40, the first portion and second portion differing in thickness by a factor of at least about 1.3.

5

42. An article as in claim 40, the first portion and second portion differing in thickness by a factor of at least about 1.5.

43. An article as in claim 40, the first portion and second portion differing in thickness by a factor of at least about 1.7.

10

44. An article as in any of claims 2-4 and 6-43, the parison having a first portion and a second portion spaced from the first portion in a parison machine direction, the first portion and second portion differing in material density by a factor of at least about 1.1.

15

45. An article as in claim 44, the first portion and second portion differing in material density by a factor of at least about 1.3.

46. An article as in claim 44, the first portion and second portion differing in material density by a factor of at least about 1.5.

20

47. An article as in claim 44, the first portion and second portion differing in material density by a factor of at least about 1.7.

48. An article as in claim 44, the first portion and second portion differing in material density by a factor of at least about 2.0.

25

49. An article as in any preceding claim having a void volume of less than 50%, and greater than 10%.

30

50. An article as in any preceding claim wherein the polymer comprises a polyolefin.

51. An article as in any preceding claim wherein the polymer comprises polypropylene.

52. An article as in any preceding claim wherein the polymer consists essentially of polypropylene.

5

53. An article as in any preceding claim wherein polymer comprises high-density polyethylene.

54. An article as in any preceding claim wherein the polymer comprises at least 80% high-  
10 density polyethylene.

55. An article as in any preceding claim wherein the polymer comprises at least 90% high-density polyethylene.

15 56. An article as in any preceding claim wherein the polymer consists essentially of high-density polyethylene.

57. An article as in any preceding claim wherein, containing nucleating agent that comprises an inorganic solid.

20

58. An article as in any preceding claim, containing a nucleating agent that comprises a filler.

59. An article as in any preceding claim, containing a nucleating agent that comprises talc.

25

60. A system for microcellular blow molding, comprising:  
extrusion apparatus including an extruder having an inlet designed to receive a precursor of polymeric microcellular material, constructed and arranged to provide a single-phase, non-nucleated solution of polymeric material and blowing agent, and a blow molding forming die fluidly connected to the extruder and having an outlet designed to release a  
30 parison of microcellular material, the apparatus including an enclosed passageway connecting the extruder inlet with the die outlet, the passageway including a nucleating pathway having

length and cross-sectional dimensions selected to create in a single-phase, non-nucleated solution of blowing agent and fluid polymeric material a pressure drop at a rate sufficient to cause microcellular nucleation; and

5 a blow mold positionable to receive a parison of microcellular material from the die outlet.

61. A system comprising:

an extruder constructed and arranged to extrude polymeric foam precursor material;

10 an accumulator, associated with the extruder, able to receive polymeric foam precursor material from the extruder and to accumulate a charge of polymeric foam precursor material; and

blow molding apparatus positionable to receive a product of the accumulator, via a forming die, and constructed and arranged to blow mold the material to form a blow molded foam polymeric article.

15

62. a system for microcellular blow molding, comprising:

an extruder having an inlet designed to receive a precursor of polymeric microcellular material, constructed and arranged to provide a single-phase, non-nucleated solution of polymeric material and blowing agent;

20 an accumulator positionable to receive polymeric foam precursor material from the extruder and to accumulate a charge of polymeric foam precursor material;

a blow molding forming die fluidly connected to the accumulator and having an outlet designed to release a parison of microcellular material; and

25 a blow mold positionable to receive a parison of microcellular material from the die outlet and constructed and arranged to form a blow molded, foam, microcellular, polymeric article,

the apparatus including an enclosed passageway connecting the extruder inlet with the die outlet, the passageway including a nucleating pathway having length and cross-sectional dimensions selected to create in a single-phase, non-nucleated solution of blowing agent and fluid polymeric material a pressure drop at a rate sufficient to cause microcellular nucleation.

30

63. A system for extruding microcellular polymeric material, comprising:



a polymer forming die including an inlet at an upstream end thereof constructed and arranged to receive microcellular extrudate precursor, an outlet at a downstream end thereof, defining a die gap, for releasing foamed polymeric material, and a fluid pathway connecting the inlet with the outlet, the fluid pathway including a nucleating pathway that decreases in cross section in a downstream direction with an included angle of greater than 4°.

64. A system for forming microcellular material:

an extruder constructed and arranged to provide microcellular extrudate precursor comprising a single-phase, non-nucleated solution of polymeric material and blowing agent;

10 an accumulator positionable to receive microcellular extrudate precursor from the extruder and to accumulate a charge of microcellular extrudate precursor; and

a polymer forming die including an inlet at an upstream end thereof constructed and arranged to receive microcellular extrudate precursor from the extruder, an outlet at a downstream end thereof, defining a die gap, for releasing foamed polymeric material, and a fluid pathway connecting the inlet with the outlet, the fluid pathway including a nucleating pathway that decreases in cross section in a downstream direction with an included angle of greater than 4°.

65. A system for extruding microcellular polymeric material, comprising:

20 a polymer forming die including an inlet at an upstream end thereof constructed and arranged to receive microcellular extrudate precursor, an outlet at a downstream end thereof, defining a die gap, for releasing foamed polymeric material, and a fluid pathway connecting the inlet with the outlet, the fluid pathway including a nucleating pathway constructed such that when a single-phase, non-nucleated solution of polymeric material and blowing agent is introduced into the die and conveyed through the die at a flow rate of about 100 lbs/hr, nucleation of the solution occurs to form a nucleated polymeric stream that is released from the die in a period of time of no more than about 0.002 second after nucleation.

66. A system as in any of claims 60-65, including a nucleating pathway having length and cross-sectional dimensions such that, when fluid polymer is passed through the pathway at a rate of about 40 lbs fluid per hour, a pressure drop rate in the fluid polymer of at least about 0.3 GPa/sec is created.

67. A system as in any of claims 60-66, including an extruder having an inlet and outlet and an enclosed, screw-containing barrel between the inlet with the outlet constructed and arranged to receive a blowing agent that is a gas under ambient conditions and to mix the blowing agent with the precursor to form a single-phase, non-nucleated solution.

5

68. A system as in any of claims 60-67 including a nucleating pathway constructed and arranged to nucleate microcellular material at a rate of at least about 60 lbs per hour.

69. A system as in claim 68 wherein the nucleating pathway constructed and arranged to  
10 nucleate microcellular material at a rate of at least about 100 lbs per hour.

70. A system as in any of claim 68 wherein the nucleating pathway is constructed and arranged to nucleate microcellular material at a rate of at least about 400 lbs per hour.

15 71. A system as in any of claims 60-70, the die having an exit gap and being constructed and arranged to vary the size of the exit gap, during extrusion, to form an extrudate having a thickness that varies as a function of distance from the exit gap.

72. A system as in any of claims 60-62 and 65-71, the die constructed and arranged to  
20 vary the size of the exit gap without changing pressure drop rate to which a polymeric material/blowing agent mixture passing through the die is subjected.

73. A system as in any of claims 60-72 including a nucleating pathway that has a cross sectional dimension that changes along its length.

25

74. A system as in claim 73, wherein the pathway decreases in cross section in a downstream direction.

75. A system as in any of claims 60-74 including a blow mold that is constructed and  
30 arranged to form a blow molded, foam, microcellular, polymeric article.

76. A system as in any of claims 60-75 including a die that includes a nucleating pathway

having length and cross-sectional dimensions selected to create, in a single-phase, non-nucleated solution of blowing agent and fluid polymeric material, a pressure drop at a rate sufficient to cause nucleation.

- 5 77. A system as in claim 76, wherein the die includes a nucleating pathway having length and cross-sectional dimensions selected to create, in a single-phase, non-nucleated solution of blowing agent and fluid polymeric material, a pressure drop at a rate sufficient to cause microcellular nucleation.
- 10 78. A system as in any of claims 61, 62 and 66-77, further comprising a die positionable to receive a product of the accumulator and to extrude a microcellular polymeric parison, and the blow molding apparatus is constructed and arranged to blow mold the parison to form a blow molded, foam, microcellular, polymeric article.
- 15 79. A system as in any of claims 60-63 and 65-78, the die constructed and arranged to vary the width of the die gap during extrusion while maintaining a constant nucleating pathway gap.
80. A system as in any of claims 63 and 65-79, further comprising an extruder constructed  
20 and arranged to prepare microcellular extrudate precursor, positionable to deliver the precursor to the die inlet.
81. A system as in claim 80, wherein the extruder is constructed and arranged to provide a  
25 the single-phase solution to the die inlet.
82. A system as in claim 80, wherein the forming die is a blow molding forming die fluidly connectable to the extruder and having an outlet designed to release a parison of microcellular material, the system further comprising a blow mold positionable to receive a  
30 parison of microcellular material from the die outlet.
83. A system as in claim 80, the extruder constructed and arranged to receive a blowing

agent that is a gas under ambient conditions and to mix the blowing agent with the precursor to form a single-phase, non-nucleated solution.

84. A system as in claim 83, further comprising an accumulator, associated with the  
5 extruder, able to receive polymeric foam precursor material from the extruder and to  
accumulate a charge of polymeric foam precursor material; and  
blow molding apparatus positionable to receive a product of the accumulator, via the  
forming die, and constructed and arranged to blow mold the material to form a blow molded  
foam polymeric article.

10

85. A system as in any of claims 60-84, the die constructed and arranged to extrude a  
tubular parison of microcellular material.

86. A system as in any of claims 60-84, the die having an exit gap and being constructed  
15 and arranged to vary the size of the exit gap, during extrusion, to form an extrudate having a  
thickness that varies as a function of distance from the exit gap.

87. A system as in any of claims 64-86, wherein the nucleating pathway decreases in cross  
section in a downstream direction with an included angle of greater than  $6^\circ$ .

20

88. A system as in claim 87, wherein the nucleating pathway decreases in cross section in  
a downstream direction with an included angle of greater than  $7^\circ$ .

89. A system as in claim 87, wherein the nucleating pathway decreases in cross section in  
25 a downstream direction with an included angle of greater than  $8^\circ$ .

90. A system as in any of claims 64-86, wherein the nucleating pathway decreases in cross  
section in a downstream direction with an included angle of greater than  $4^\circ$  and less than  $18^\circ$ .

30 91. A system as in claim 90, wherein the nucleating pathway decreases in cross section in  
a downstream direction with an included angle of greater than  $4^\circ$  and less than  $8^\circ$ .

92. A system as in claim 65, wherein the nucleating pathway decreases in cross section in a downstream direction with an included angle of greater than 4°.

93. A method comprising:

5 extruding microcellular polymeric foam extrudate from an extruder die while varying the thickness of the extrudate.

94. A method as in claim 93, comprising providing a single-phase, non-nucleated solution of polymeric material and a blowing agent that is a gas under ambient conditions, nucleating  
10 the single-phase solution by subjecting the solution to a high pressure drop rate, and extruding polymeric foam extrudate that is a product of the single-phase solution.

95. A method as in claim 94, comprising extruding a microcellular parison suitable for blow molding.

15

96. A method as in claim 95, further comprising blow molding the parison to form a microcellular, blow-molded article.

97. A method as in any of claims 93-96, the extrudate or parison having a void volume of  
20 at least about 10%.

98. A method as in any of claims 93-97, comprising establishing a stream of a fluid, single-phase non-nucleated solution of a precursor of foamed polymeric material and a blowing agent, continuously nucleating the solution to form a nucleated polymeric fluid, and  
25 extruding the polymeric foam extrudate from the nucleated polymeric fluid.

99. A method as in claim 98, the step of continuously nucleating involving creating sites of nucleation of the blowing agent in the stream by subjecting the stream to conditions of solubility change sufficient to create sites of nucleation in the solution in the absence of an  
30 auxiliary nucleating agent.

100. A method as in any of claims 93-99, comprising establishing a stream of a fluid,

single-phase non-nucleated solution of a precursor of foamed polymeric material and a supercritical fluid blowing agent.

101. A method as in any of claims 98-100, involving subjecting the stream to a pressure drop at a pressure drop rate sufficient to create sites of nucleation.

102. A method as in claim 101, involving subjecting the stream to a pressure drop at a pressure drop rate sufficient to create sites of nucleation at a density of at least about  $10^7$  sites/cm<sup>3</sup>.

10

103. A method as in claim 101, involving subjecting the stream to a pressure drop at a pressure drop rate of at least about 0.3 GPa/sec to create sites of nucleation.

104. A method as in any of claims 93-103, comprising extruding polymeric foam extrudate into ambient conditions from an extruder die while varying the thickness of the extrudate.

105. A method as in any of claims 93-104, involving establishing a stream of fluid, single-phase non-nucleated solution of a precursor of foamed polymeric material and a blowing agent by introducing, into fluid polymeric material flowing at a rate of at least about 10 lbs./hr, a fluid that is a gas under ambient conditions and, in a period of less than about one minute, creating a single-phase solution of the fluid and the polymer, the fluid present in the solution in an amount of at least about 2% by weight based on the weight of the solution.

106. A method as in claim 105, comprising continuously nucleating the solution by continuously decreasing the pressure within successive, continuous portions of the flowing, single-phase stream at a rate which increases.

107. A method as in claim 106, wherein the concentration of the blowing agent in the homogeneous single-phase non-nucleated solution is at least about 5 percent, by weight, of the solution.

108. A method as in any of claims 93-107, involving establishing a stream of fluid, single-

phase solution of a precursor of foamed polymeric material and a blowing agent, wherein the concentration of the blowing agent in the homogeneous single-phase non-nucleated solution is at least about 7 percent, by weight, of the solution.

5 109. A method as in claim 108 wherein the concentration of the blowing agent in the homogeneous single-phase non-nucleated solution is at least about 10 percent, by weight, of the solution.

110. A method as in any of claims 108-109, wherein the blowing agent is supercritical  
10 carbon dioxide.

111. A method comprising:  
providing an extruded polymeric microcellular foam parison; and  
subjecting the parison to blow molding conditions.

15

112. A method comprising:  
providing a polymeric foam parison; and  
subjecting the parison to blow molding conditions of at least about 15 psi thereby  
expanding at least a portion of the parison by at least about 50% in circumference and forming  
20 a blow-molded article, while maintaining a relatively unchanged density by increasing the  
density of the parison by no more than about 20% in going from the parison to the blow-  
molded article.

113. A method comprising:  
25 providing a polymeric microcellular foam parison; and  
without heating the parison subjecting the parison to blow molding conditions.

114. A method as in any of claims 111-113, wherein the foam parison is of void fraction of  
at least about 10%.

30

115. A method as in any of claims 111-114, wherein the parison has a pre-blown thickness  
of less than about 0.100 inch.

116. A method as in any of claims 111-115, comprising extruding the parison from a mixture of polymeric material and blowing agent, the blowing agent present in the mixture in an amount less than about 3% by weight based on the weight of the mixture.

5 117. A method as in any of claims 111-116, comprising extruding the parison from a single-phase solution of polymeric material and supercritical blowing agent.

118. A method as in any of claims 116-117, wherein the blowing agent comprises carbon dioxide.

10

119. A method as in any of claims 116-117, wherein the blowing agent comprises nitrogen.

120. A method as in any of claims 111-119, the subjecting step involving applying pressure of at least about 1.5 bar internal of the parison.

15

121. A method as in claim 120, involving applying pressure of at least about 3 bar internal of the parison.

122. A method as in claim 120, involving applying pressure of at least about 5 bar internal  
20 of the parison.

123. A method as in claim 120, involving applying pressure of at least 10 bar internal of the parison.

25 124. A method as in any of claims 111-123, involving forming a final blow-molded product that is essentially free of a supporting, non-foam structure, the article being essentially closed cell, having a wall thickness of less than about 0.075 inch.

125. A method as in any of claims 111-124, comprising continuously extruding polymeric  
30 foam extrudate and continuously subjecting the extrudate to blow molding conditions.

126. A method as in any of claims 111-125, comprising:



providing an extruded polymeric foam parison having a first portion and a second portion spaced from the first portion in the parison machine direction, the first portion and the second portion differing in thickness by a factor of at least about 1.1; and

subjecting the parison to blow molding conditions.

5

127. A method as in claim 126, the first portion and the second portion differing in thickness by a factor of at least about 1.3.

128. A method as in claim 126, the first portion and the second portion differing in  
10 thickness by a factor of at least about 1.5.

129. A method as in claim 126, the first portion and the second portion differing in thickness by a factor of at least about 1.7.

15 130. A method as in any of claims 126-129, comprising:

providing an extruded polymeric foam parison having a first portion and a second portion spaced from the first portion in the parison machine direction, the first portion and the second portion differing in material density by a factor of at least about 1.1; and  
subjecting the parison to blow molding conditions.

20

131. A method as in any of claims 111-130, comprising:

providing an extruded parison of polymeric material of melt flow no more than about 0.2 g/10 min; and  
subjecting the parison to blow molding conditions.

25

132. A method comprising:

extruding a polymeric foam extrudate from a extruder die in a machine direction while varying the temperature of the extrudate exiting the die thereby forming an extrudate having a first portion and a second portion spaced from the first portion in the machine direction, the  
30 first portion and the second portion differing in material density by a factor of at least about 1.1.

133. A method as in claim 132, comprising successively varying the temperature of the extrudate exiting the die via a cold gas stream.

134. A method as informing a foam article comprising:

- 5 conveying polymeric material in a downstream direction in a polymer processing apparatus, the polymeric material consisting essentially of high-density polyethylene; introducing a physical blowing agent into the polymeric material in the polymer processing apparatus; and forming a foam article from the polymeric material.

10

135. A method of forming a microcellular article comprising:

- conveying polymeric material in a downstream direction in a polymer processing apparatus, the polymeric material comprising a semi-crystalline polymer, and a nucleating agent in an amount between about 2.5 and about 7 weight percent, by weight of the polymeric material; and forming a microcellular article from the polymeric material.

15

136. A method as in claims 134 or 135 further comprising introducing blowing agent into the polymeric material in the polymer processing apparatus in an amount less than 1.5 weight percent, by weight of the polymeric material.

20

137. A method as in any of claims 134-136 further comprising introducing blowing agent into the polymeric material in an amount less than 0.5 weight percent, by weight of the polymeric material, to form a solution of blowing agent and polymeric material

25

138. A method as in any of claims 134-137, comprising introducing blowing agent into the polymeric material, the blowing agent comprising carbon dioxide.

139. A method as in any of claims 134-137, comprising introducing blowing agent comprising nitrogen into the polymeric material.

30

140. A method as in any of claims 134-137, comprising introducing blowing agent that is a

mixture of carbon dioxide and nitrogen into the polymeric material.

141. A method as in any of claims 134-140 further comprising inducing a pressure drop rate of less than 1.0 GPa/s in the solution of blowing agent and polymeric material.

5

142. A method as in claim 141 wherein the pressure drop rate is less than 0.10 GPa/s.

143. A method as in claim 141 wherein the pressure drop rate is less than 0.05 GPa/s.

10 144. A method as in any of claims 134-143, wherein the polymeric material comprises between about 5 and about 7 weight percent nucleating agent, by weight of the polymeric material.

145. A method as in any of claims 134-144 wherein the polymer comprises a polyolefin.

15

146. A method as in any of claims 134-145 wherein the polymer comprises polypropylene.

147. A method as in any of claims 134-146 wherein the polymer consists essentially of polypropylene.

20

148. A method as in any of claims 134-147 wherein polymer comprises high-density polyethylene.

25 149. A method as in claim 148 wherein the polymer comprises at least 80% high-density polyethylene.

150. A method as in claim 148 wherein the polymer comprises at least 90% high-density polyethylene.

30 151. A method as in claim 148 wherein the polymer consists essentially of high-density polyethylene.

152 A method as in claim 148 wherein the article is essentially free of residual chemical blowing agent and reaction-by-products of chemical blowing agent.

153. A method as in any of claims 134-152 wherein the nucleating agent comprises an  
5 inorganic solid.

154. A method as in any of claims 134-152 wherein the nucleating agent comprises a filler.

155. A method as in any of claims 134-152 wherein the nucleating agent comprise talc.  
10

156. A method as in any of claims 134-155 wherein forming the microcellular article comprises extruding the polymeric material through a die connected to a downstream end of the polymer processing apparatus.

157. A method as in any of claims 134-155 wherein forming the microcellular article comprises molding the polymeric material in an injection mold connected to a downstream end of the polymer processing space.  
15

158. A method as in any of claims 134-155 wherein forming the microcellular article  
20 comprises blow molding the article.

159. A method as in any of claims 134-158 wherein the foam article includes a plurality of cells having an average cell size of less than 100 microns.

25 160. A method as in any of claims 134-158 wherein the foam article includes a plurality of cells having an average cell size of less than 50 microns.

161. A method as in any of claims 134-158 wherein the foam article includes a plurality of cells having an average cell size of less than 20 microns.  
30

162. A method as in any of claims 134-161, wherein the polymeric material is essentially free of residual chemical blowing agents or by-product of chemical blowing agent.

163. A method as in any of claims 134-162 wherein the foam article has a void volume of greater than 10%.

164. A method as in claim 163 wherein the foam article has a void volume of greater than  
5 20%.

165. A method as in claim 163 wherein the foam article has a void volume of greater than 50%.

10 166. A method as in claim 163 wherein the foam article has a void volume of greater than 10% and less than 50%.

167. A method comprising:

introducing a single-phase, non-nucleated solution of polymeric material and blowing  
15 agent into an inlet of a polymer forming die, nucleating the solution to form a nucleated polymeric stream, and releasing the nucleated stream as a polymeric microcellular extrudate from an outlet of the die in a period of time of no more than about 0.002 second after nucleation.

20 168. A method as in claim 167, wherein the die includes a nucleating pathway that decreases in cross section in a downstream direction with an included angle of greater than 4°.

169. A method as in claim 167, wherein the die includes a nucleating pathway that decreases in cross section in a downstream direction with an included angle of greater than 6°.

25

170. A method as in claim 167, wherein the die includes a nucleating pathway that decreases in cross section in a downstream direction with an included angle of greater than 7°.

171. A method as in claim 167, wherein the die includes a nucleating pathway that  
30 decreases in cross section in a downstream direction with an included angle of greater than 8°.

172. A method as in any of claims 167-171, comprising introducing a single-phase, non-

nucleated solution of HDPE and blowing agent into the inlet of the polymer forming die.

173. A method as in any of claims 167-172, comprising nucleating the single-phase, non-nucleated solution of polymeric material and blowing agent in the die by subjecting the  
5 solution to a pressure drop in the solution at a pressure drop rate of at least about 0.3 GPa/sec.

174. A method as in any of claims 167-173, wherein the single-phase, non-nucleated solution includes blowing agent at a level of no more than about 3% by weight based on the weight of the solution.

10

175. A method as in any of claims 167-174, comprising releasing the nucleated stream as a polymeric microcellular extrudate from an outlet of the die in a period of time of no more than about 0.001 second after nucleation.

15 176. A method as in any of claims 167-175, comprising nucleating the solution by subjecting the solution to a pressure drop at a high pressure drop rate.

177. A method as in claim 176, comprising nucleating the solution by subjecting the solution to a pressure drop at a rate sufficient to cause microcellular nucleation.

20

178. A method as in claim 176, comprising nucleating the solution by subjecting the solution to a pressure drop at a pressure drop rate of at least about 1.0 GPa/sec.

179. A method as in any of claims 167-178, comprising varying the width of a die gap  
25 defined by the die outlet, while releasing polymeric microcellular extrudate from the outlet, while maintaining a constant nucleating pathway gap within the die by which the solution is nucleated.

180. A method as in any of claims 167-179, wherein the die is a blow molding forming die,  
30 the method involving releasing the polymeric material extrudate from the outlet of the die as a microcellular parison, the method further comprising blow molding the parison into a blow-molded microcellular polymeric article.

181. A method as in any of claims 167-180, wherein the blowing agent is an atmospheric gas.

182. A method as in claim 181, wherein the blowing agent is carbon dioxide.

5

183. A method as in any of claims 180-182, comprising introducing the single-phase solution of polymeric material and blowing agent into the inlet of the die from an accumulator.

10 184. A method as in any of claims 167-183, comprising releasing extrudate from the die outlet having a thickness that varies as a function of distance from the die outlet.

185. A method as in any of claims 112-131, wherein the parison is an extruded polymeric microcellular foam parison.

15

186. A method as in any of claims 111-131, wherein the foam parison is of void fraction of at least about 20%.

187. A method as in any of claims 111-131, wherein the foam parison is of void fraction of  
20 at least about 30%.

188. A method as in any of claims 111-131, wherein the foam parison is of void fraction of at least about 40%.

25 189. A device comprising:

a polymer forming die including an inlet at an upstream end thereof constructed and arranged to receive a single-phase, homogeneous solution of polymeric fluid and blowing agent that is a gas under ambient conditions, an outlet at a downstream end thereof, defining a die gap, for releasing foamed polymeric material, and a fluid pathway connecting the inlet  
30 with the outlet, the fluid pathway including a nucleating pathway, the die constructed and arranged to vary the width of the die gap during extrusion while maintaining a constant nucleating pathway gap.

190. A device as in claim 189, the nucleating pathway having length and cross-sectional dimensions that, when fluid polymer is passed through the pathway at a rate greater than 40 lbs fluid per hour, creates a pressure drop in the fluid polymer of at least about 0.3 GPa/sec.



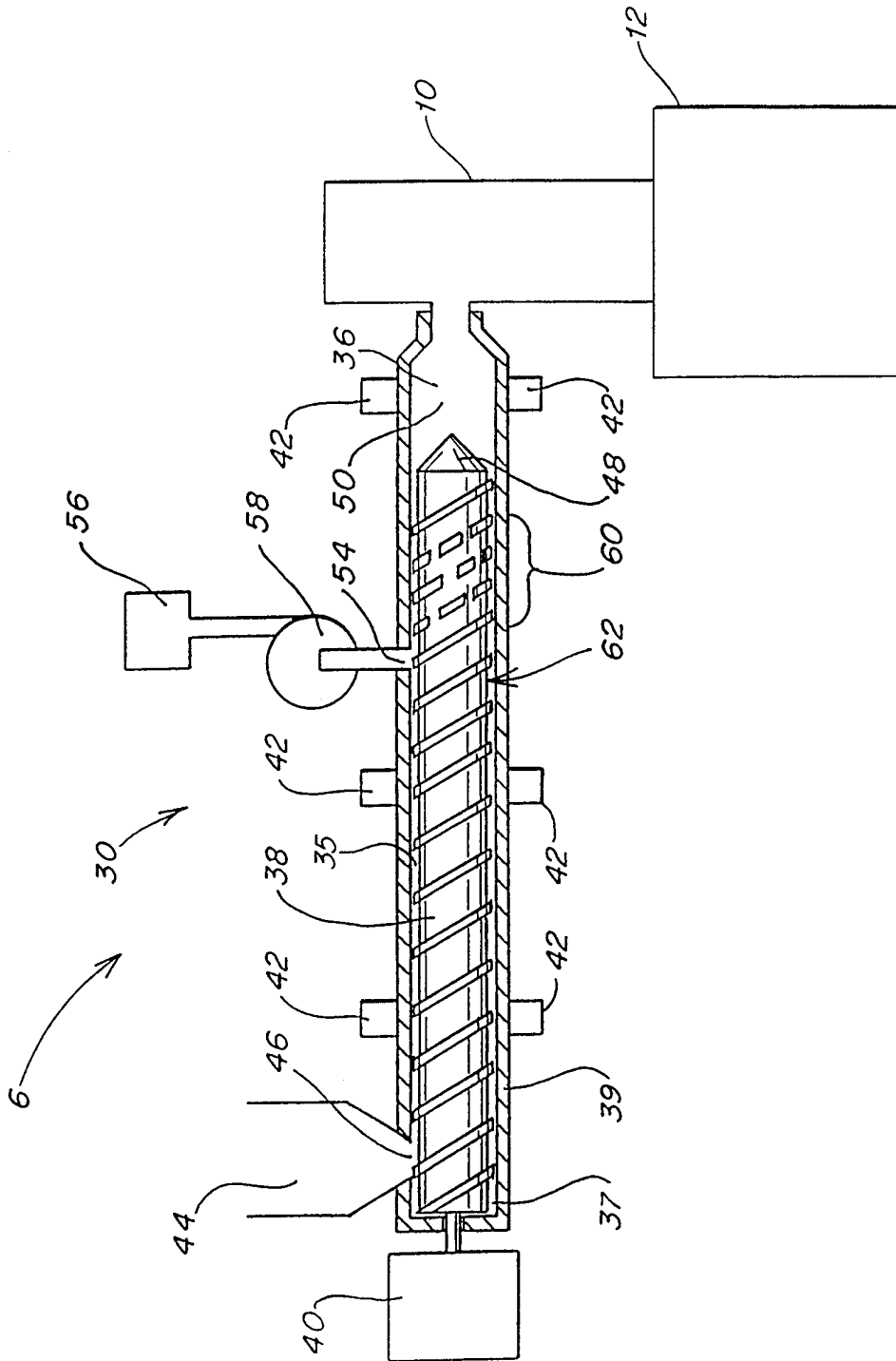

FIG. 1

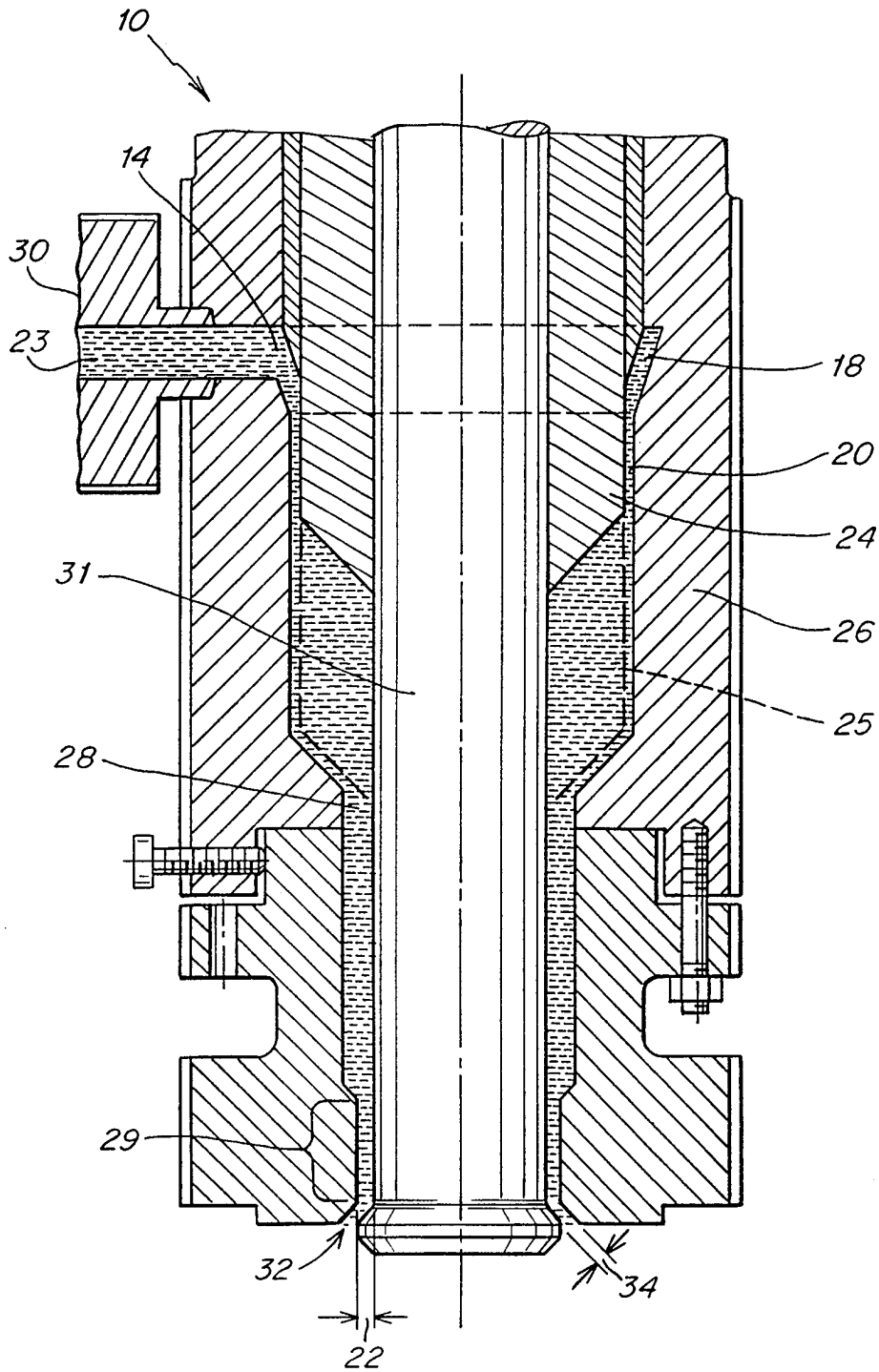

FIG. 2

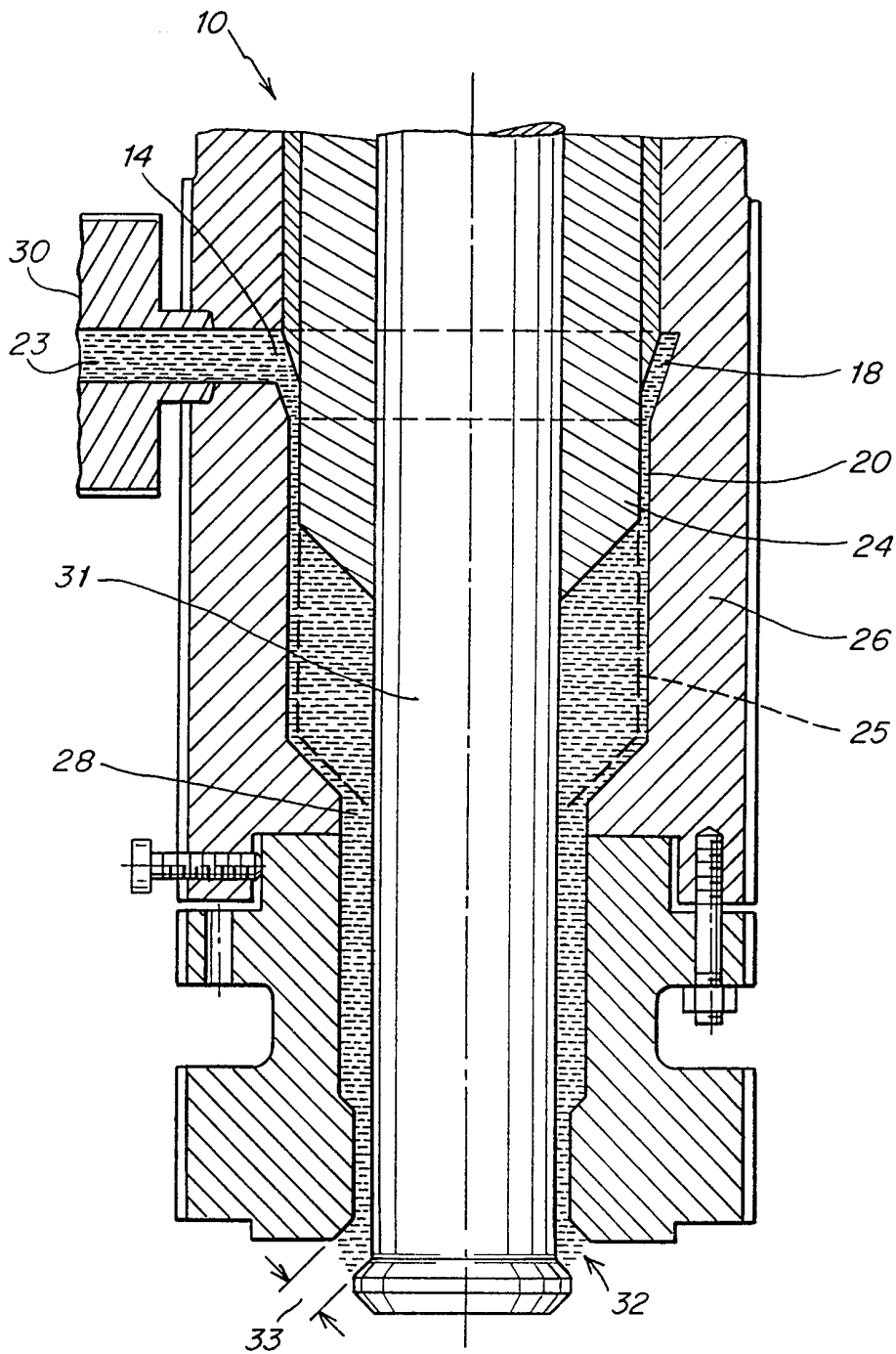

FIG. 3

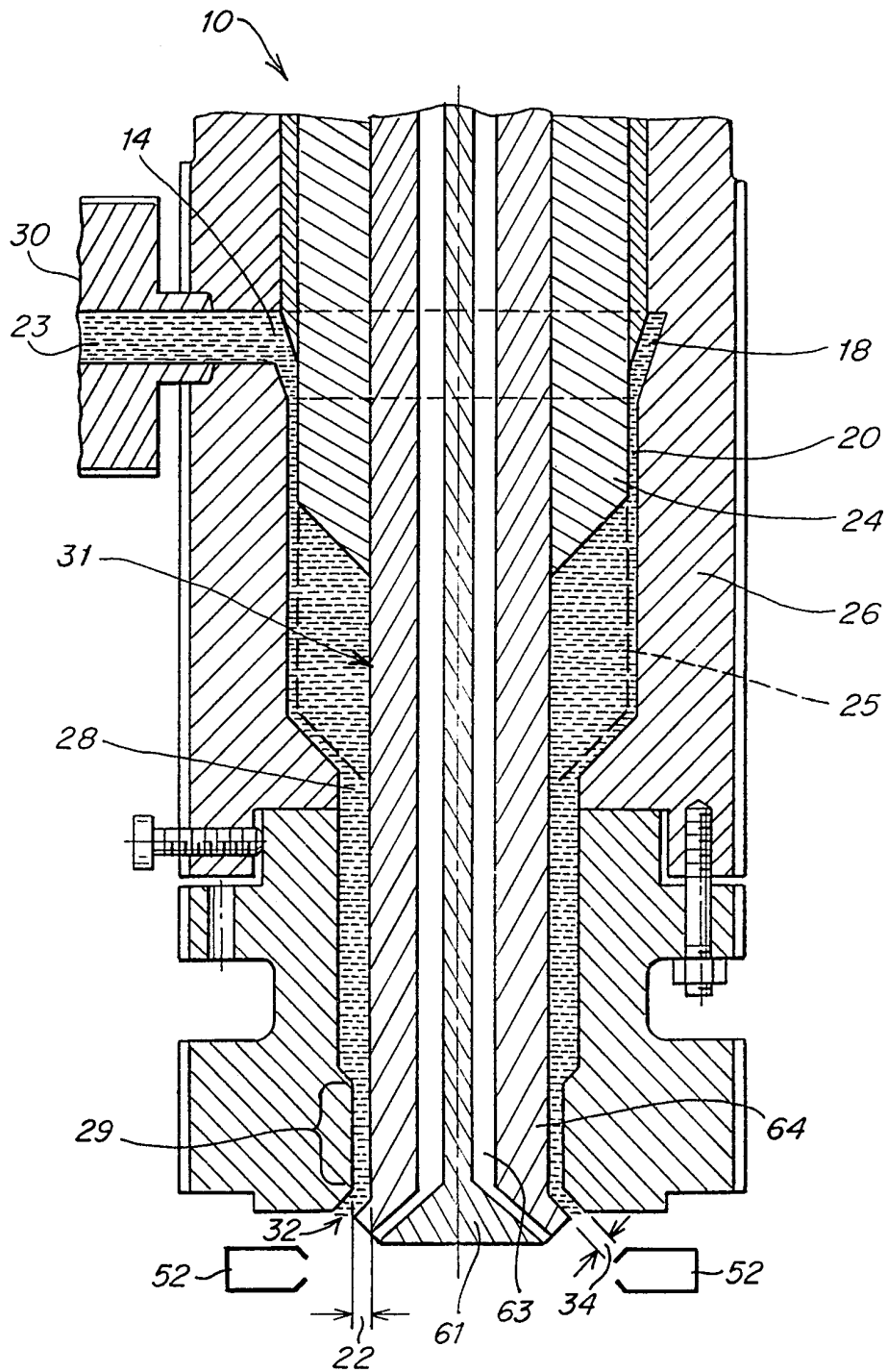
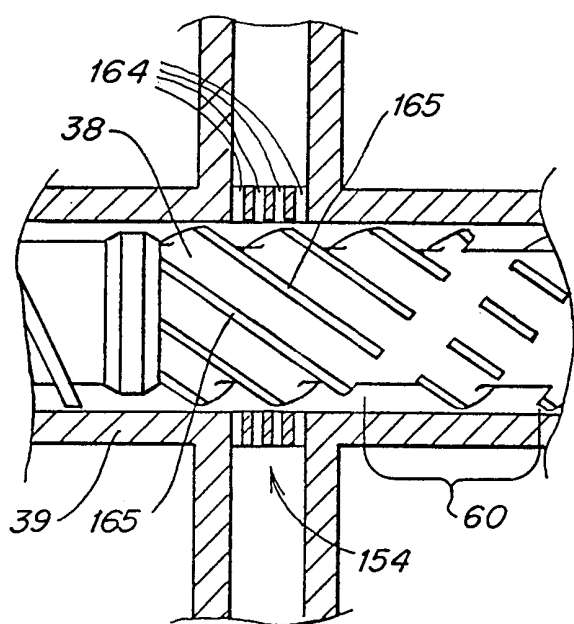

FIG. 4



*FIG. 5*

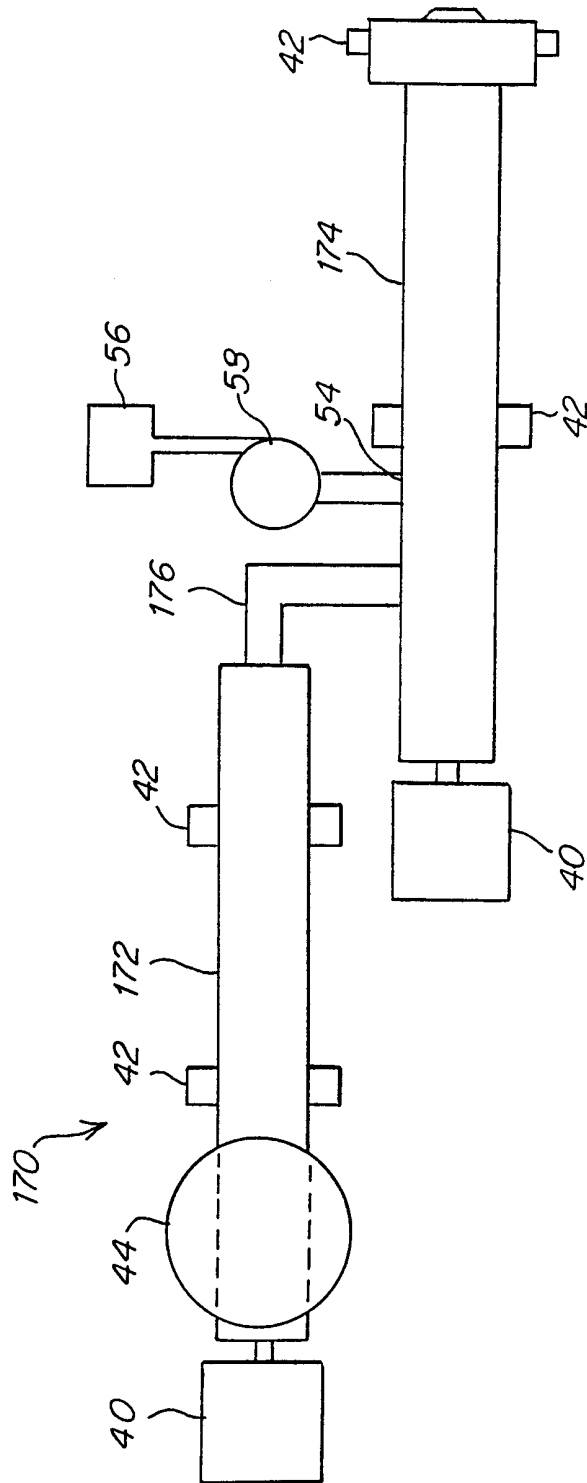

FIG. 6

7/10

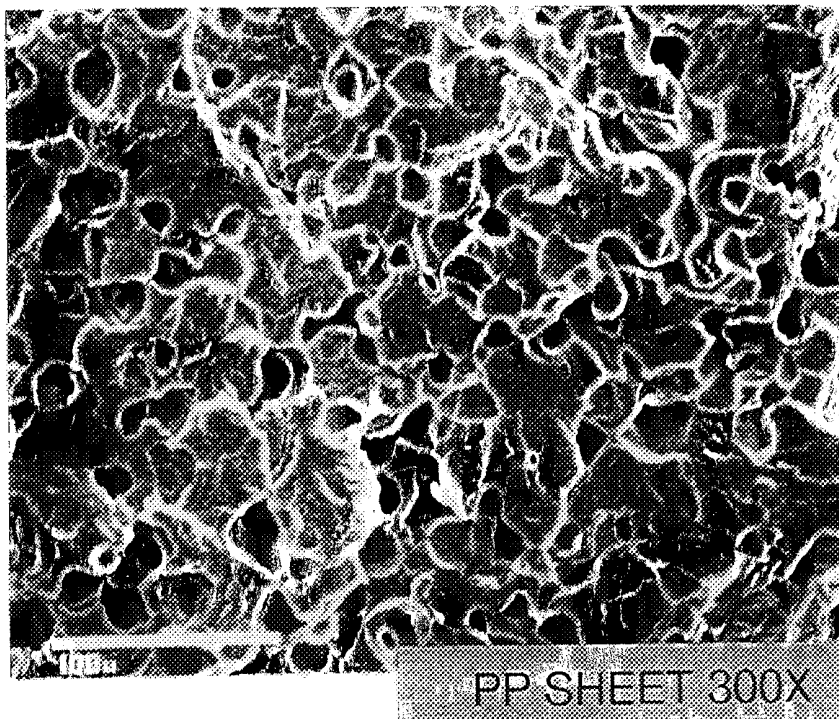

Fig. 7

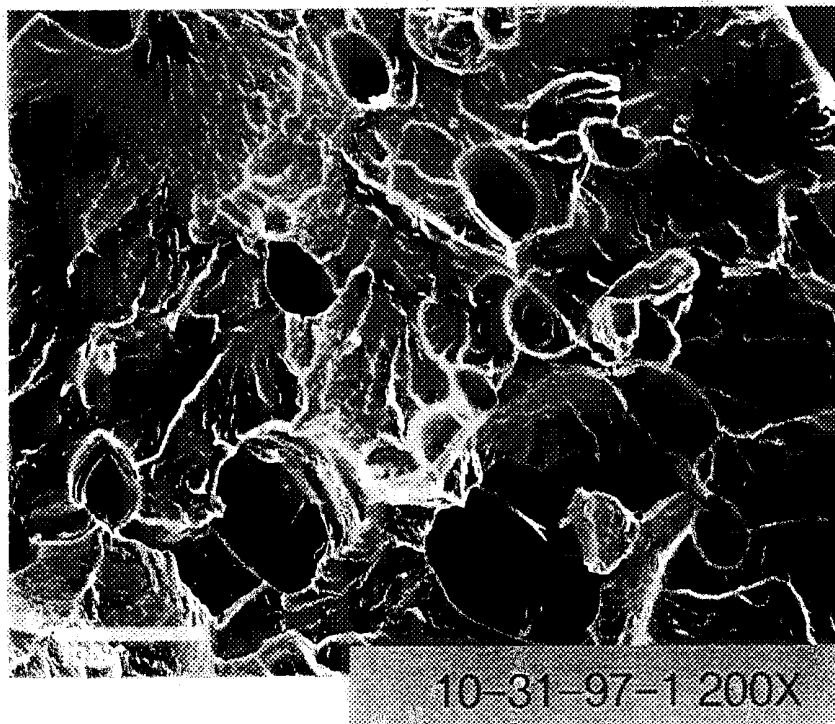

Fig. 8

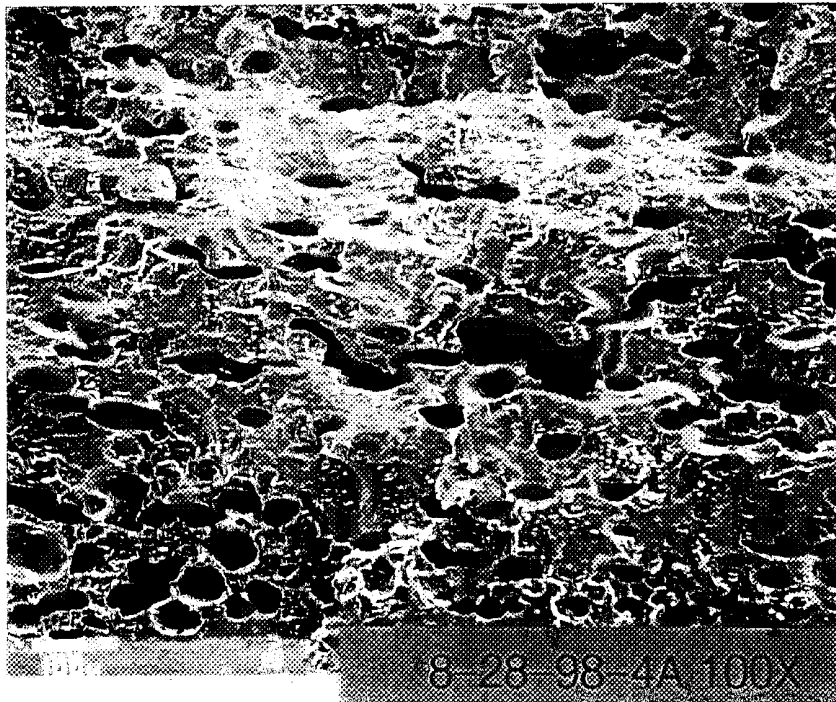

Fig. 9

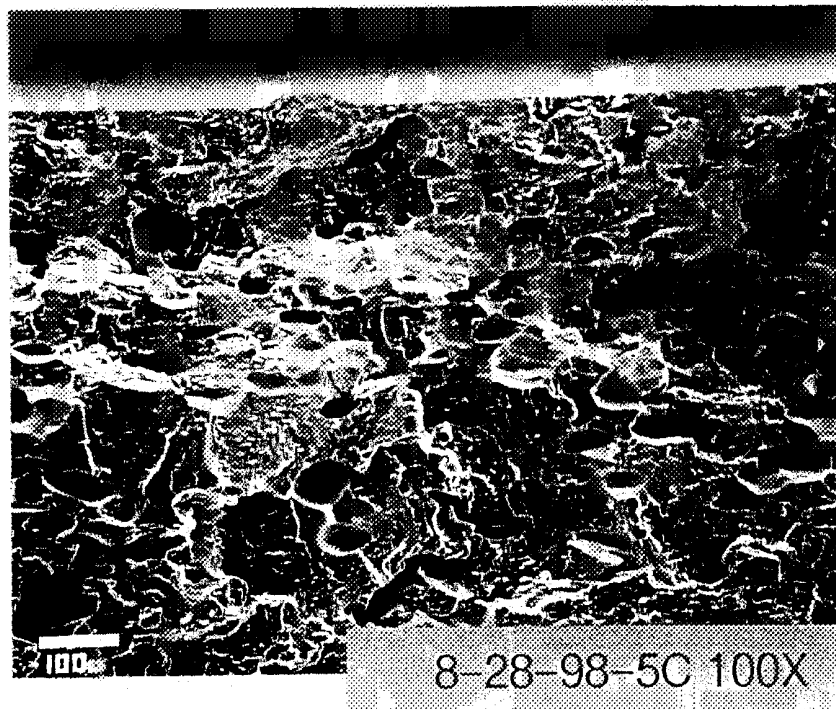

Fig. 10



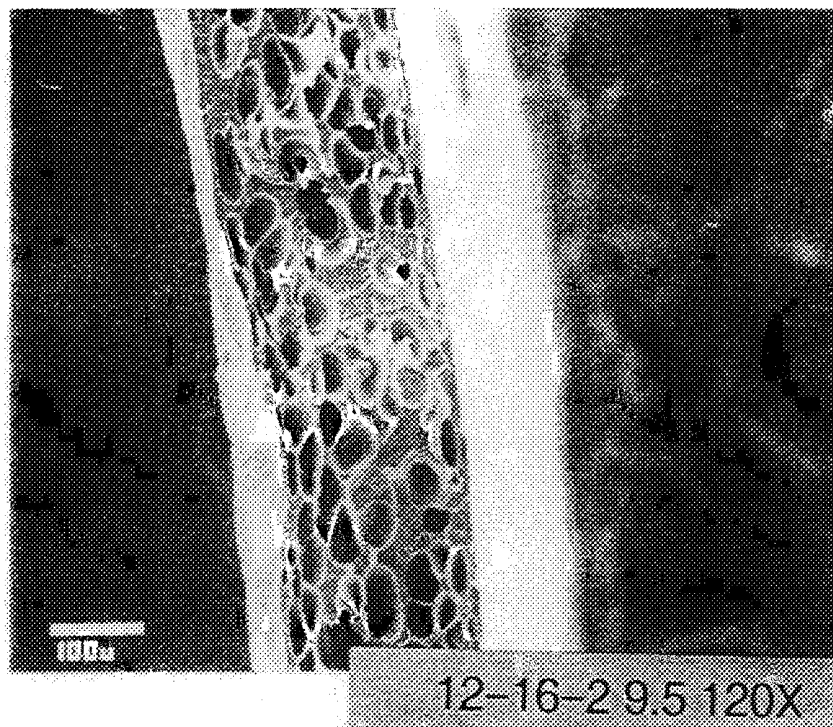

Fig. 11

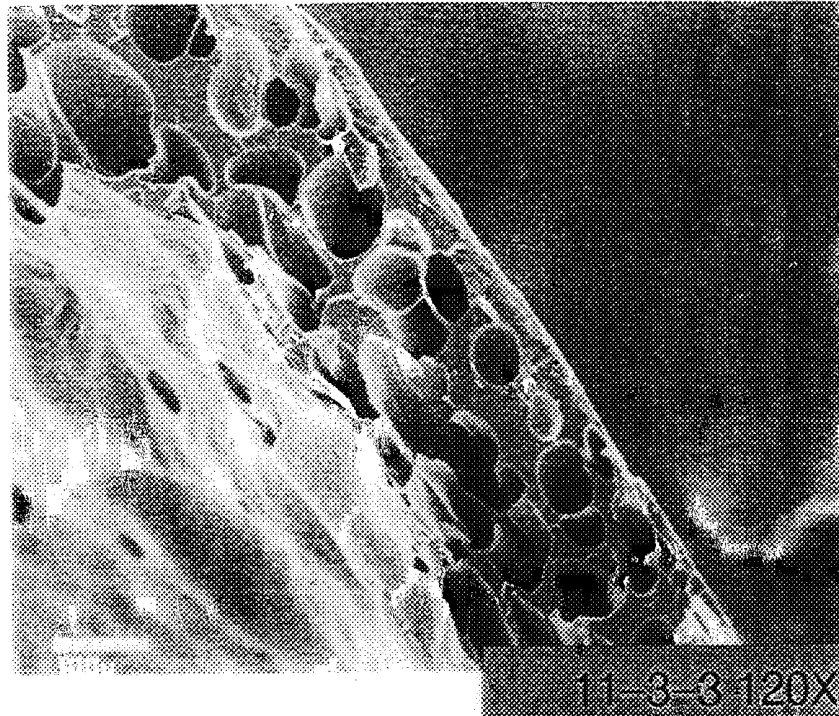

Fig. 12

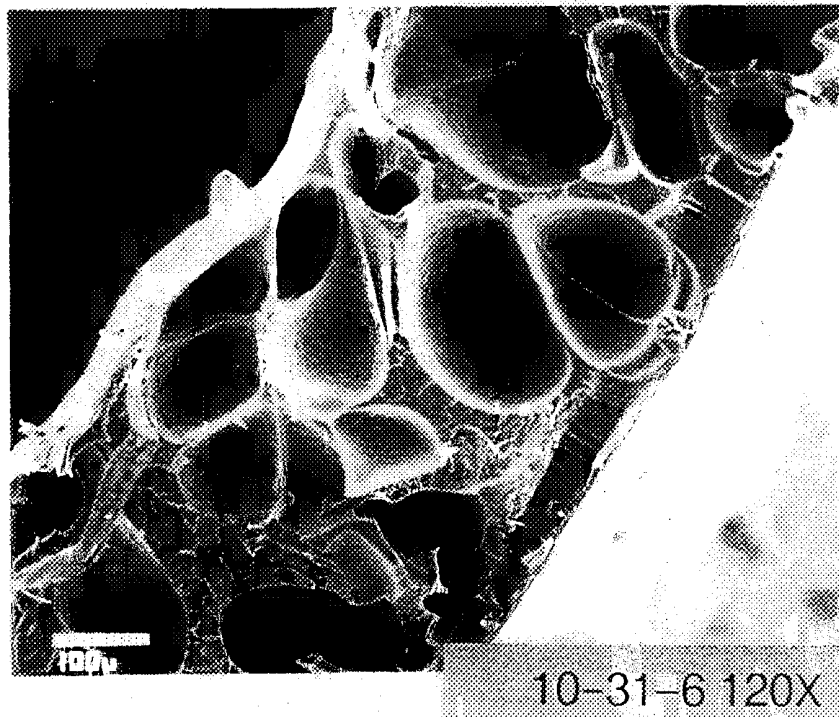

Fig. 13

# INTERNATIONAL SEARCH REPORT

International Application No  
PCT/US 98/27118

**A. CLASSIFICATION OF SUBJECT MATTER**  
IPC 6 C08J9/00 B65D1/02

According to International Patent Classification (IPC) or to both national classification and IPC

**B. FIELDS SEARCHED**

Minimum documentation searched (classification system followed by classification symbols)  
IPC 6 C08J B65D

Documentation searched other than minimum documentation to the extent that such documents are included in the fields searched

Electronic data base consulted during the international search (name of data base and, where practical, search terms used)

**C. DOCUMENTS CONSIDERED TO BE RELEVANT**

Category °	Citation of document, with indication, where appropriate, of the relevant passages	Relevant to claim No.
X	US 4 627 177 A (MEYERS STUART R) 9 December 1986	1
A	see column 3, line 49 - column 4, line 11 see claims 1,3 ---	6-59
X	GB 1 456 171 A (KRAUSS MAFFEI AG) 17 November 1976 see page 1, line 92 - page 2, line 10 see claims ---	1,8-11
A	US 5 468 530 A (GOETZ WALTER ET AL) 21 November 1995 see column 6, line 26-29 see column 6, line 41-44 see column 8, line 60 - column 9, line 3 -----	6

Further documents are listed in the continuation of box C.

Patent family members are listed in annex.

° Special categories of cited documents :

- "A" document defining the general state of the art which is not considered to be of particular relevance
- "E" earlier document but published on or after the international filing date
- "L" document which may throw doubts on priority claim(s) or which is cited to establish the publication date of another citation or other special reason (as specified)
- "O" document referring to an oral disclosure, use, exhibition or other means
- "P" document published prior to the international filing date but later than the priority date claimed

- "T" later document published after the international filing date or priority date and not in conflict with the application but cited to understand the principle or theory underlying the invention
- "X" document of particular relevance; the claimed invention cannot be considered novel or cannot be considered to involve an inventive step when the document is taken alone
- "Y" document of particular relevance; the claimed invention cannot be considered to involve an inventive step when the document is combined with one or more other such documents, such combination being obvious to a person skilled in the art.
- "&" document member of the same patent family

Date of the actual completion of the international search

22 April 1999

Date of mailing of the international search report

07/05/1999

Name and mailing address of the ISA

European Patent Office, P.B. 5818 Patentlaan 2  
NL - 2280 HV Rijswijk  
Tel. (+31-70) 340-2040, Tx. 31 651 epo nl,  
Fax: (+31-70) 340-3016

Authorized officer

Oudot, R

# INTERNATIONAL SEARCH REPORT

Information on patent family members

International Application No

PCT/US 98/27118

Patent document cited in search report	Publication date	Patent family member(s)	Publication date
US 4627177 A	09-12-1986	NONE	
GB 1456171 A	17-11-1976	NONE	
US 5468530 A	21-11-1995	DE 4339509 A DE 59407873 D EP 0654505 A JP 7196916 A	24-05-1995 08-04-1999 24-05-1995 01-08-1995