

(19) World Intellectual Property Organization  
International Bureau



(43) International Publication Date  
17 July 2003 (17.07.2003)

PCT

(10) International Publication Number  
**WO 03/057188 A1**

- (51) International Patent Classification<sup>7</sup>: **A61K 9/00**, 31/52
- (21) International Application Number: PCT/US02/37489
- (22) International Filing Date:  
21 November 2002 (21.11.2002)
- (25) Filing Language: English
- (26) Publication Language: English
- (30) Priority Data:  
60/332,279 21 November 2001 (21.11.2001) US
- (71) Applicant: **ALEXZA MOLECULAR DELIVERY CORPORATION** [US/US]; 1001 E.Meadow Circle, Palo Alto, CA 94303 (US).
- (72) Inventor: **RABINOWITZ, Joshua, D.**; 750 N. Shoreline Boulevard, #98, Mountain View, CA 94043 (US).
- (74) Agents: **ECKMAN, Richard, R.** et al.; Morrison & Foerster LLP, 755 Page Mill Road, Palo Alto, CA 94304-1018 (US).
- (81) Designated States (*national*): AE, AG, AL, AM, AT, AU, AZ, BA, BB, BG, BR, BY, BZ, CA, CH, CN, CO, CR, CU, CZ, DE, DK, DM, DZ, EC, EE, ES, FI, GB, GD, GE, GH, GM, HR, HU, ID, IL, IN, IS, JP, KE, KG, KP, KR, KZ, LC, LK, LR, LS, LT, LU, LV, MA, MD, MG, MK, MN, MW, MX, MZ, NO, NZ, OM, PH, PL, PT, RO, RU, SC, SD, SE, SG, SI, SK, SL, TJ, TM, TN, TR, TT, TZ, UA, UG, UZ, VC, VN, YU, ZA, ZM, ZW.
- (84) Designated States (*regional*): ARIPO patent (GH, GM, KE, LS, MW, MZ, SD, SL, SZ, TZ, UG, ZM, ZW), Eurasian patent (AM, AZ, BY, KG, KZ, MD, RU, TJ, TM), European patent (AT, BE, BG, CH, CY, CZ, DE, DK, EE, ES, FI, FR, GB, GR, IE, IT, LU, MC, NL, PT, SE, SK, TR), OAPI patent (BF, BJ, CF, CG, CI, CM, GA, GN, GQ, GW, ML, MR, NE, SN, TD, TG).
- Published:**  
— with international search report  
— with amended claims
- For two-letter codes and other abbreviations, refer to the "Guidance Notes on Codes and Abbreviations" appearing at the beginning of each regular issue of the PCT Gazette.*



**WO 03/057188 A1**

(54) Title: DELIVERY OF CAFFEINE THROUGH AN INHALATION ROUTE

(57) Abstract: The present invention relates to the delivery of caffeine through an inhalation route. Specifically, it relates to aerosols containing caffeine that are used in inhalation therapy. In a composition aspect of the present invention, the aerosol comprises particles comprising at least 5 percent by weight of caffeine. In a method aspect of the present invention, caffeine is delivered to a mammal through an inhalation route. The method comprises: a) heating a composition, wherein the composition comprises at least 5 percent by weight of caffeine, to form a vapor; and, b) allowing the vapor to cool, thereby forming a condensation aerosol comprising particles, which is inhaled by the mammal. In a kit aspect of the present invention, a kit for delivering caffeine through an inhalation route to a mammal is provided which comprises: a) a composition comprising at least 5 percent by weight of caffeine; and, b) a device that forms a caffeine containing aerosol from the composition, for inhalation by the mammal.

## **DELIVERY OF CAFFEINE THROUGH AN INHALATION ROUTE**

### **CROSS-REFERENCE TO RELATED APPLICATIONS**

[0001] This application claims priority to U.S. provisional application Serial No. 60/332,279 entitled "Delivery of Caffeine through an Inhalation Route," filed November 21, 2001, Joshua D. Rabinowitz, the entire disclosure of which is hereby incorporated by reference.

### **FIELD OF THE INVENTION**

[0002] The present invention relates to the delivery of caffeine through an inhalation route. Specifically, it relates to aerosols containing caffeine that are used in inhalation therapy.

### **BACKGROUND OF THE INVENTION**

[0003] Caffeine is the most commonly used drug in the world. In moderate doses (75-150 mg), it elevates neural activity in many parts of the brain, postpones fatigue, and enhances performance of simple intellectual tasks and physical work that involves endurance. The most common therapeutic use of caffeine is to relieve pain, especially headache pain, although it is also a mild diuretic and a respiratory stimulant.

[0004] Typically, caffeine is administered either orally or intravenously. These delivery methods have a number of limitations. Peak plasma concentrations following oral administration are generally not reached until 50 to 75 minutes. Intravenous injection, while rapidly delivering the drug, involves the discomfort and risk of infection associated with catheterization or injection.

[0005] It is desirable to provide a new route of administration for caffeine that allows for the rapid acquisition of peak plasma concentrations without the disadvantages of catheterization or injection. The provision of such a route is an object of the present invention.

**SUMMARY OF THE INVENTION**

[0006] The present invention relates to the delivery of caffeine through an inhalation route. Specifically, it relates to aerosols containing caffeine that are used in inhalation therapy.

[0007] In a composition aspect of the present invention, the aerosol comprises particles comprising at least 5 percent by weight of caffeine. Preferably, the particles comprise at least 10 percent by weight of caffeine. More preferably, the particles comprise at least 20 percent, 30 percent, 40 percent, 50 percent, 60 percent, 70 percent, 80 percent, 90 percent, 95 percent, 97 percent, 99 percent, 99.5 percent or 99.97 percent by weight of caffeine.

[0008] Typically, the aerosol particles comprise less than 10 percent by weight of caffeine degradation products. Preferably, the particles comprise less than 5 percent by weight of caffeine degradation products. More preferably, the particles comprise less than 2.5, 1, 0.5, 0.1 or 0.03 percent by weight of caffeine degradation products.

[0009] Typically, the aerosol has an inhalable aerosol drug mass density of between 1 mg/L and 100 mg/L. Preferably, the aerosol has an inhalable aerosol drug mass density of between 2 mg/L and 60 mg/L. More preferably, the aerosol has an inhalable aerosol drug mass density of between 3 mg/L and 30 mg/L.

[0010] Typically, the aerosol has an inhalable aerosol particle density greater than  $10^6$  particles/mL. Preferably, the aerosol has an inhalable aerosol particle density greater than  $10^7$  particles/mL. More preferably, the aerosol has an inhalable aerosol particle density greater than  $10^8$  particles/mL.

[0011] Typically, the aerosol particles have a mass median aerodynamic diameter of less than 5 microns. Preferably, the particles have a mass median aerodynamic diameter of less than 3 microns. More preferably, the particles have a mass median aerodynamic diameter of less than 2 or 1 micron(s).

[0012] Typically, the aerosol is formed by heating a composition containing caffeine to form a vapor and subsequently allowing the vapor to condense into an aerosol.

[0013] In a method aspect of the present invention, caffeine is delivered to a mammal through an inhalation route. The method comprises: a) heating a composition, wherein the composition comprises at least 5 percent by weight of caffeine; and, b) allowing the vapor to cool, thereby forming a condensation aerosol comprising particles, which is inhaled by the mammal. Preferably, the composition that is heated comprises at

least 10 percent by weight of caffeine. More preferably, the composition comprises 20 percent, 30 percent, 40 percent, 50 percent, 60 percent, 70 percent, 80 percent, 90 percent, 95 percent, 97 percent, 99 percent, 99.5 percent, 99.9 percent or 99.97 percent by weight of caffeine.

[0014] Typically, the delivered aerosol particles comprise at least 5 percent by weight of caffeine. Preferably, the particles comprise at least 10 percent by weight of caffeine. More preferably, the particles comprise at least 20 percent, 30 percent, 40 percent, 50 percent, 60 percent, 70 percent, 80 percent, 90 percent, 95 percent, 97 percent, 99 percent, 99.5 percent, 99.9 percent or 99.97 percent by weight of caffeine.

[0015] Typically, the delivered aerosol particles comprise less than 10 percent by weight of caffeine degradation products. Preferably, the particles comprise less than 5 percent by weight of caffeine degradation products. More preferably, the particles comprise less than 2.5, 1, 0.5, 0.1 or 0.03 percent by weight of caffeine degradation products.

[0016] Typically, the particles of the delivered condensation aerosol have a mass median aerodynamic diameter of less than 5 microns. Preferably, the particles have a mass median aerodynamic diameter of less than 3 microns. More preferably, the particles have a mass median aerodynamic diameter of less than 2 or 1 micron(s).

[0017] Typically, the delivered aerosol has an inhalable aerosol drug mass density of between 1 mg/L and 100 mg/L. Preferably, the aerosol has an inhalable aerosol drug mass density of between 2 mg/L and 60 mg/L. More preferably, the aerosol has an inhalable aerosol drug mass density of between 3 mg/L and 30 mg/L.

[0018] Typically, the delivered aerosol has an inhalable aerosol particle density greater than  $10^6$  particles/mL. Preferably, the aerosol has an inhalable aerosol particle density greater than  $10^7$  particles/mL. More preferably, the aerosol has an inhalable aerosol particle density greater than  $10^8$  particles/mL.

[0019] Typically, the rate of inhalable aerosol particle formation of the delivered condensation aerosol is greater than  $10^8$  particles per second. Preferably, the aerosol is formed at a rate greater than  $10^9$  inhalable particles per second or  $10^{10}$  inhalable particles per second.

[0020] Typically, the delivered aerosol is formed at a rate greater than 1 mg/second. Preferably, the aerosol is formed at a rate greater than 5 mg/second. More preferably, the aerosol is formed at a rate greater than 20 mg/second.

[0021] Typically, the condensation aerosol delivers between 1 mg and 100 mg of caffeine to the mammal in a single inspiration. Preferably, between 2 mg and 60 mg of caffeine are delivered to the mammal in a single inspiration. More preferably, between 3 mg and 30 mg of caffeine are delivered to the mammal in a single inspiration.

[0022] Typically, the delivered condensation aerosol results in a peak plasma concentration of caffeine in the mammal in less than 1 h. Preferably, the peak plasma concentration is reached in less than 0.5 h. More preferably, the peak plasma concentration is reached in less than 0.2, 0.1, 0.05, 0.02 or 0.01 h.

[0023] In a kit aspect of the present invention, a kit for delivering caffeine through an inhalation route to a mammal is provided which comprises: a) a composition comprising at least 5 percent by weight of caffeine; and, b) a device that forms a caffeine containing aerosol from the composition, for inhalation by the mammal. Preferably, the composition comprises at least 10 percent by weight of caffeine. More preferably, the composition comprises at least 20 percent, 30 percent, 40 percent, 50 percent, 60 percent, 70 percent, 80 percent, 90 percent, 95 percent, 97 percent, 99 percent, 99.5 percent, 99.9 percent or 99.97 percent by weight of caffeine.

[0024] Typically, the device contained in the kit comprises: a) an element for heating the caffeine composition to form a vapor; b) an element allowing the vapor to cool to form an aerosol; and, c) an element permitting the mammal to inhale the aerosol.

#### **BRIEF DESCRIPTION OF THE FIGURE**

[0025] Fig. 1 shows a device used to deliver caffeine containing aerosols to a mammal through an inhalation route.

#### **DETAILED DESCRIPTION OF THE INVENTION**

##### *Definitions*

[0026] "Aerodynamic diameter" of a given particle refers to the diameter of a spherical droplet with a density of 1 g/mL (the density of water) that has the same settling velocity as the given particle.

[0027] "Aerosol" refers to a suspension of solid or liquid particles in a gas.

[0028] "Aerosol drug mass density" refers to the mass of caffeine per unit volume of aerosol.

- [0029] “Aerosol mass density” refers to the mass of particulate matter per unit volume of aerosol.
- [0030] “Aerosol particle density” refers to the number of particles per unit volume of aerosol.
- [0031] “Condensation aerosol” refers to an aerosol formed by vaporization of a substance followed by condensation of the substance into an aerosol.
- [0032] “Caffeine” refers to 3,7-dihydro-1,3,7-trimethyl-1*H*-purine-2,6-dione, which is a free base.
- [0033] “Caffeine” degradation product refers to a compound resulting from a chemical modification of caffeine. The modification, for example, can be the result of a thermally or photochemically induced reaction. Such reactions include, without limitation, oxidation and hydrolysis.
- [0034] “Inhalable aerosol drug mass density” refers to the aerosol drug mass density produced by an inhalation device and delivered into a typical patient tidal volume.
- [0035] “Inhalable aerosol mass density” refers to the aerosol mass density produced by an inhalation device and delivered into a typical patient tidal volume.
- [0036] “Inhalable aerosol particle density” refers to the aerosol particle density of particles of size between 100 nm and 5 microns produced by an inhalation device and delivered into a typical patient tidal volume.
- [0037] “Mass median aerodynamic diameter” or “MMAD” of an aerosol refers to the aerodynamic diameter for which half the particulate mass of the aerosol is contributed by particles with an aerodynamic diameter larger than the MMAD and half by particles with an aerodynamic diameter smaller than the MMAD.
- [0038] “Rate of aerosol formation” refers to the mass of aerosolized particulate matter produced by an inhalation device per unit time.
- [0039] “Rate of inhalable aerosol particle formation” refers to the number of particles of size between 100 nm and 5 microns produced by an inhalation device per unit time.
- [0040] “Rate of drug aerosol formation” refers to the mass of aerosolized caffeine produced by an inhalation device per unit time.
- [0041] “Settling velocity” refers to the terminal velocity of an aerosol particle undergoing gravitational settling in air.

[0042] “Typical patient tidal volume” refers to 1 L for an adult patient and 15 mL/kg for a pediatric patient.

[0043] “Vapor” refers to a gas, and “vapor phase” refers to a gas phase. The term “thermal vapor” refers to a vapor phase, aerosol, or mixture of aerosol-vapor phases, formed preferably by heating.

#### Formation of Caffeine Containing Aerosols

[0044] Any suitable method is used to form the aerosols of the present invention. A preferred method, however, involves heating a composition comprising caffeine to produce a vapor, followed by cooling of the vapor such that it condenses to provide a caffeine comprising aerosol (condensation aerosol). The composition is heated in one of two forms: as pure active compound (*i.e.*, pure caffeine); or, as a mixture of active compound and a pharmaceutically acceptable excipient. Typically, the composition is heated on a solid support.

[0045] Pharmaceutically acceptable excipients are either volatile or nonvolatile. Volatile excipients, when heated, are concurrently volatilized, aerosolized and inhaled with caffeine. Classes of such excipients are known in the art and include, without limitation, gaseous, supercritical fluid, liquid and solid solvents. The following is a list of exemplary carriers within the classes: water; terpenes, such as menthol; alcohols, such as ethanol, propylene glycol, glycerol and other similar alcohols; dimethylformamide; dimethylacetamide; wax; supercritical carbon dioxide; dry ice; and mixtures thereof.

[0046] Solid supports on which the composition is heated are of a variety of shapes. Examples of such shapes include, without limitation, cylinders of less than 1.0 mm in diameter, boxes of less than 1.0 mm thickness and virtually any shape permeated by small (*e.g.*, less than 1.0 mm-sized) pores. Preferably, solid supports provide a large surface to volume ratio (*e.g.*, greater than 100 per meter) and a large surface to mass ratio (*e.g.*, greater than 1 cm<sup>2</sup> per gram).

[0047] A solid support of one shape can also be transformed into another shape with different properties. For example, a flat sheet of 0.25 mm thickness has a surface to volume ratio of approximately 8000 per meter. Rolling the sheet into a hollow cylinder of 1 cm diameter produces a support that retains the high surface to mass ratio of the original sheet but has a lower surface to volume ratio (about 400 per meter).

[0048] A number of different materials are used to construct the solid supports. Classes of such materials include, without limitation, metals, inorganic materials,

carbonaceous materials and polymers. The following are examples of the material classes: aluminum, silver, gold, stainless steel, copper and tungsten; silica, glass, silicon and alumina; graphite, porous carbons, carbon yarns and carbon felts; polytetrafluoroethylene and polyethylene glycol. Combinations of materials and coated variants of materials are used as well.

[0049] Where aluminum is used as a solid support, aluminum foil is a suitable material. Examples of silica, alumina and silicon based materials include amorphous silica S-5631 (Sigma, St. Louis, MO), BCR171 (an alumina of defined surface area greater than 2 m<sup>2</sup>/g from Aldrich, St. Louis, MO) and a silicon wafer as used in the semiconductor industry. Carbon yarns and felts are available from American Kynol, Inc., New York, NY. Chromatography resins such as octadecyl silane chemically bonded to porous silica are exemplary coated variants of silica.

[0050] The heating of the caffeine compositions is performed using any suitable method. Examples of methods by which heat can be generated include the following: passage of current through an electrical resistance element; absorption of electromagnetic radiation, such as microwave or laser light; and, exothermic chemical reactions, such as exothermic solvation, hydration of pyrophoric materials and oxidation of combustible materials.

#### Delivery of Caffeine Containing Aerosols

[0051] Caffeine containing aerosols of the present invention are delivered to a mammal using an inhalation device. Where the aerosol is a condensation aerosol, the device has at least three elements: an element for heating a caffeine containing composition to form a vapor; an element allowing the vapor to cool, thereby providing a condensation aerosol; and, an element permitting the mammal to inhale the aerosol. Various suitable heating methods are described above. The element that allows cooling is, in its simplest form, an inert passageway linking the heating means to the inhalation means. The element permitting inhalation is an aerosol exit portal that forms a connection between the cooling element and the mammal's respiratory system.

[0052] One device used to deliver caffeine containing aerosol is described in reference to Fig. 1. Delivery device 100 has a proximal end 102 and a distal end 104, a heating module 106, a power source 108, and a mouthpiece 110. A caffeine composition is deposited on a surface 112 of heating module 106. Upon activation of a user activated switch 114, power source 108 initiates heating of heating module 106 (e.g., through ignition



of combustible fuel or passage of current through a resistive heating element). The caffeine composition volatilizes due to the heating of heating module 106 and condenses to form a condensation aerosol prior to reaching the mouthpiece 110 at the proximal end of the device 102. Air flow traveling from the device distal end 104 to the mouthpiece 110 carries the condensation aerosol to the mouthpiece 110, where it is inhaled by the mammal.

[0053] Devices, if desired, contain a variety of components to facilitate the delivery of caffeine containing aerosols. For instance, the device may include any component known in the art to control the timing of drug aerosolization relative to inhalation (*e.g.*, breath-actuation), to provide feedback to patients on the rate and/or volume of inhalation, to prevent excessive use (*i.e.*, “lock-out” feature), to prevent use by unauthorized individuals, and/or to record dosing histories.

#### Dosage of Caffeine Containing Aerosols

[0054] For analgesis effect or the relief of migraine headache, caffeine is given orally at doses between 30 mg and 100 mg, generally in combination with another active compound (*e.g.*, aspirin or ergotamine, respectively). As an aerosol, between 3 and 30 mg of caffeine is generally provided per inspiration for these indications. A typical dosage of a caffeine aerosol is either administered as a single inhalation or as a series of inhalations taken within an hour or less (dosage equals sum of inhaled amounts). Where the drug is administered as a series of inhalations, a different amount may be delivered in each inhalation. The dosage amount of caffeine in aerosol form is generally no greater than twice the standard dose of the drug given through other methods.

[0055] One can determine the appropriate dose of a caffeine containing aerosol to treat a particular condition using methods such as animal experiments and a dose-finding (Phase I/II) clinical trial. One animal experiment involves measuring plasma concentrations of drug in an animal after its exposure to the aerosol. Mammals such as dogs or primates are typically used in such studies, since their respiratory systems are similar to that of a human. Initial dose levels for testing in humans are generally less than or equal to the dose in the mammal model that resulted in plasma drug levels associated with a therapeutic effect in humans. Dose escalation in humans is then performed, until either an optimal therapeutic response is obtained or a dose-limiting toxicity is encountered.

#### Analysis of Caffeine Containing Aerosols

[0056] Purity of a caffeine containing aerosol is determined using a number of methods, examples of which are described in Sekine *et al.*, *Journal of Forensic Science* 32:1271-1280 (1987) and Martin *et al.*, *Journal of Analytic Toxicology* 13:158-162 (1989). One method involves forming the aerosol in a device through which a gas flow (*e.g.*, air flow) is maintained, generally at a rate between 0.4 and 60 L/min. The gas flow carries the aerosol into one or more traps. After isolation from the trap, the aerosol is subjected to an analytical technique, such as gas or liquid chromatography, that permits a determination of composition purity.

[0057] A variety of different traps are used for aerosol collection. The following list contains examples of such traps: filters; glass wool; impingers; solvent traps, such as dry ice-cooled ethanol, methanol, acetone and dichloromethane traps at various pH values; syringes that sample the aerosol; empty, low-pressure (*e.g.*, vacuum) containers into which the aerosol is drawn; and, empty containers that fully surround and enclose the aerosol generating device. Where a solid such as glass wool is used, it is typically extracted with a solvent such as ethanol. The solvent extract is subjected to analysis rather than the solid (*i.e.*, glass wool) itself. Where a syringe or container is used, the container is similarly extracted with a solvent.

[0058] The gas or liquid chromatograph discussed above contains a detection system (*i.e.*, detector). Such detection systems are well known in the art and include, for example, flame ionization, photon absorption and mass spectrometry detectors. An advantage of a mass spectrometry detector is that it can be used to determine the structure of caffeine degradation products.

[0059] Particle size distribution of a caffeine containing aerosol is determined using any suitable method in the art (*e.g.*, cascade impaction). An Andersen Eight Stage Non-viable Cascade Impactor (Andersen Instruments, Smyrna, GA) linked to a furnace tube by a mock throat (USP throat, Andersen Instruments, Smyrna, GA) is one system used for cascade impaction studies.

[0060] Inhalable aerosol mass density is determined, for example, by delivering a drug-containing aerosol into a confined chamber via an inhalation device and measuring the mass collected in the chamber. Typically, the aerosol is drawn into the chamber by having a pressure gradient between the device and the chamber, wherein the chamber is at lower pressure than the device. The volume of the chamber should approximate the tidal volume of an inhaling patient.

[0061] Inhalable aerosol drug mass density is determined, for example, by delivering a drug-containing aerosol into a confined chamber via an inhalation device and measuring the amount of active drug compound collected in the chamber. Typically, the aerosol is drawn into the chamber by having a pressure gradient between the device and the chamber, wherein the chamber is at lower pressure than the device. The volume of the chamber should approximate the tidal volume of an inhaling patient. The amount of active drug compound collected in the chamber is determined by extracting the chamber, conducting chromatographic analysis of the extract and comparing the results of the chromatographic analysis to those of a standard containing known amounts of drug.

[0062] Inhalable aerosol particle density is determined, for example, by delivering aerosol phase drug into a confined chamber via an inhalation device and measuring the number of particles of given size collected in the chamber. The number of particles of a given size may be directly measured based on the light-scattering properties of the particles. Alternatively, the number of particles of a given size may be determined by measuring the mass of particles within the given size range and calculating the number of particles based on the mass as follows: Total number of particles = Sum (from size range 1 to size range N) of number of particles in each size range. Number of particles in a given size range = Mass in the size range/Mass of a typical particle in the size range. Mass of a typical particle in a given size range =  $\pi \cdot D^3 \cdot \rho / 6$ , where D is a typical particle diameter in the size range (generally, the mean of the boundary MMADs defining the size range) in microns,  $\rho$  is the particle density (in g/mL) and mass is given in units of picograms ( $g^{-12}$ ).

[0063] Rate of inhalable aerosol particle formation is determined, for example, by delivering aerosol phase drug into a confined chamber via an inhalation device. The delivery is for a set period of time (e.g., 3 s), and the number of particles of a given size collected in the chamber is determined as outlined above. The rate of particle formation is equal to the number of 100 nm to 5 micron particles collected divided by the duration of the collection time.

[0064] Rate of aerosol formation is determined, for example, by delivering aerosol phase drug into a confined chamber via an inhalation device. The delivery is for a set period of time (e.g., 3 s), and the mass of particulate matter collected is determined by weighing the confined chamber before and after the delivery of the particulate matter. The rate of aerosol formation is equal to the increase in mass in the chamber divided by the duration of the collection time. Alternatively, where a change in mass of the delivery

device or component thereof can only occur through release of the aerosol phase particulate matter, the mass of particulate matter may be equated with the mass lost from the device or component during the delivery of the aerosol. In this case, the rate of aerosol formation is equal to the decrease in mass of the device or component during the delivery event divided by the duration of the delivery event.

[0065] Rate of drug aerosol formation is determined, for example, by delivering a caffeine containing aerosol into a confined chamber via an inhalation device over a set period of time (*e.g.*, 3 s). Where the aerosol is pure caffeine, the amount of drug collected in the chamber is measured as described above. The rate of drug aerosol formation is equal to the amount of caffeine collected in the chamber divided by the duration of the collection time. Where the caffeine containing aerosol comprises a pharmaceutically acceptable excipient, multiplying the rate of aerosol formation by the percentage of caffeine in the aerosol provides the rate of drug aerosol formation.

#### Utility of Caffeine Containing Aerosols

[0066] The following are typical uses for caffeine aerosols of the present invention: respiratory stimulation; acute treatment of fatigue; enhancement of alertness; treatment of narcolepsy; induction of a positive state of mind; analgesia; treatment of nicotine craving; treatment of cocaine and other elicit drug craving; and, treatment of headache, including without limitation, tension headache, migraine headache and headache due to leakage of cerebrospinal fluid.

[0067] The following examples are meant to illustrate, rather than limit, the present invention.

[0068] Caffeine is commercially available from Sigma ([www.sigma-aldrich.com](http://www.sigma-aldrich.com)).

**EXAMPLE 1***Volatilization of Caffeine*

[0069] A furnace tube was connected to a vacuum outlet. In between the tube and the outlet was placed a glass wool plug. The furnace tube was preheated to 300 °C. Caffeine (82 mg) was added to the preheated tube, and an air flow rate of 2 L/min was applied using the vacuum. After 2 min, the furnace tube was allowed to cool. The walls of the tube outside of the heating zone and the glass wool were extracted with solvent. Analysis of the extract showed that approximately 40% of the caffeine had volatilized at a purity level >99%.

**EXAMPLE 2***Particle Size of Caffeine Aerosol*

[0070] An Andersen Eight Stage Non-viable Cascade Impactor (Andersen Instruments, Smyrna, GA) was linked to a furnace tube by a mock throat (USP throat, Andersen Instruments, Smyrna, GA) for cascade impaction studies. The furnace tube was preheated to 350 °C. To the preheated tube was added 100 mg caffeine. After 15 s, an air flow of 28 L/min was applied for 2 min. The tube was allowed to cool, and the results from the cascade impactor were analyzed (see Table 1). MMAD of the collected aerosol was 1.1 microns with a geometric standard deviation of 3.

Table 1: Determination of the particle size of a caffeine condensation aerosol by cascade impaction using an Andersen 8-stage non-viable cascade impactor.

Stage	Particle size range (microns)	Average particle size (microns)	Mass collected (mg)
0	9.0-10.0	9.5	1.2
1	5.8-9.0	7.4	(0.6)
2	4.7-5.8	5.25	3.0
3	3.3-4.7	4.0	5.1
4	2.1-3.3	2.7	6.7
5	1.1-2.1	1.6	6.4
6	0.7-1.1	0.9	5.2
7	0.4-0.7	0.55	5.2
8	0-0.4	0.2	2.6

## CLAIMS

1. An aerosol comprising particles, wherein the particles comprise at least 5 percent by weight of caffeine.
2. The aerosol according to Claim 1, wherein the particles comprise at least 95 percent by weight of caffeine.
3. The aerosol according to Claim 1, wherein the particles comprise at least 97 percent by weight of caffeine.
4. The aerosol according to Claim 3, wherein the aerosol comprises less than 1 percent by weight of caffeine degradation products.
5. The aerosol according to Claim 3, wherein the aerosol has an inhalable aerosol drug mass density of between 3 mg/L and 30 mg/L.
6. The aerosol according to Claim 3, wherein the aerosol has an inhalable aerosol particle density greater than  $10^8$  particles/mL.
7. The aerosol according to Claim 3, wherein the particles have a mass median aerodynamic diameter less than 2.
8. The aerosol according to Claim 3, wherein the aerosol is formed by heating a composition containing caffeine to form a vapor, which subsequently condenses to form an aerosol.
9. A method for delivering caffeine to a mammal through an inhalation route, wherein the method comprises:
  - (a) heating a composition, wherein the composition comprises at least 5 percent by weight of caffeine to form a vapor; and,
  - (b) allowing the vapor to cool, thereby forming a condensation aerosol comprising particles

which is inhaled by the mammal.

10. The method according to Claim 9, wherein the aerosol comprises at least 95 percent by weight of caffeine.

11. The method according to Claim 9, wherein the aerosol comprises at least 97 percent by weight of caffeine.

12. The method according to Claim 11, wherein the aerosol particles comprise less than 1 percent by weight of caffeine degradation products.

13. A kit for delivering caffeine through an inhalation route to a mammal, wherein the kit comprises:

- a) a composition comprising at least 5 percent by weight of caffeine; and,
- b) a device that forms a caffeine containing aerosol from the composition for inhalation by the mammal.

14. The kit according to Claim 13, wherein the composition comprises at least 90 percent by weight of caffeine.

15. The kit according to Claim 14, wherein the device contained in the kit comprises:

- a) an element for heating the caffeine composition to form a vapor;
- b) an element allowing the vapor to cool to form an aerosol; and,
- c) an element permitting the mammal to inhale the aerosol.



**AMENDED CLAIMS**

[received by the International Bureau on 23 May 2003 (23.05.03);  
original claims 1-4, 9-13 and 15 amended; remaining claim unchanged (2 pages )]

1. An orally inhalable condensation aerosol substantially free of organic or aqueous solvents comprising particles, wherein the particles have a MMAD of less than 3 and comprise at least 50 percent by weight of caffeine and less than 3 percent thermal degradation products.
2. An orally inhalable aerosol substantially free of organic or aqueous solvents, comprising particles, wherein the particles have an MMAD of less than 3 and a purity level of at least 95 percent caffeine.
3. The aerosol according to Claim 2, wherein the purity level is at least 97 percent caffeine.
4. The aerosol according to Claim 3, wherein the aerosol comprises less than 1 percent of caffeine degradation products.
5. The aerosol according to Claim 3, wherein the aerosol has an inhalable aerosol drug mass density of between 3 mg/L and 30 mg/L.
6. The aerosol according to Claim 3, wherein the aerosol has an inhalable aerosol particle density greater than  $10^8$  particles/mL.
7. The aerosol according to Claim 3, wherein the particles have a mass median aerodynamic diameter less than 2.
8. The aerosol according to Claim 3, wherein the aerosol is formed by heating a composition containing caffeine to form a vapor, which subsequently condenses to form an aerosol.
9. A method for producing a caffeine aerosol for oral inhalation comprising the steps of :

(a) heating a composition to form a vapor, wherein the composition is substantially free of organic or aqueous solvents and comprises at least 50 percent by weight of caffeine; and

(b) allowing the vapor to cool, thereby forming a condensation aerosol comprising particles, wherein the particles have a MMAD of less than 3 and comprise less than 3 percent thermal degradation products of the composition.

10. The method according to Claim 9, wherein the composition comprises at least 95 percent by weight of caffeine.

11. The method according to Claim 9, wherein the step of heating comprises heating the composition to a temperature between about 300°C and about 350°C.

12. The method according to Claim 11, wherein the aerosol particles comprise less than 1 percent of caffeine degradation products.

13. A kit for delivering caffeine through an oral inhalation route comprising:

a) a composition substantially free of organic or aqueous solvents comprising at least 50 percent by weight of caffeine; and

b) a device that forms a caffeine containing condensation aerosol for oral inhalation from the composition, the condensation aerosol having less than 5 percent composition degradation products and particles with a MMAD of less than 3.

14. The kit according to Claim 13, wherein the composition comprises at least 90 percent by weight of caffeine.

15. The kit according to Claim 13, wherein the device contained in the kit comprises:

a) an element for heating the caffeine composition to form a vapor;

b) an element allowing the vapor to cool to form an aerosol; and,

c) an element permitting oral inhalation of the aerosol.

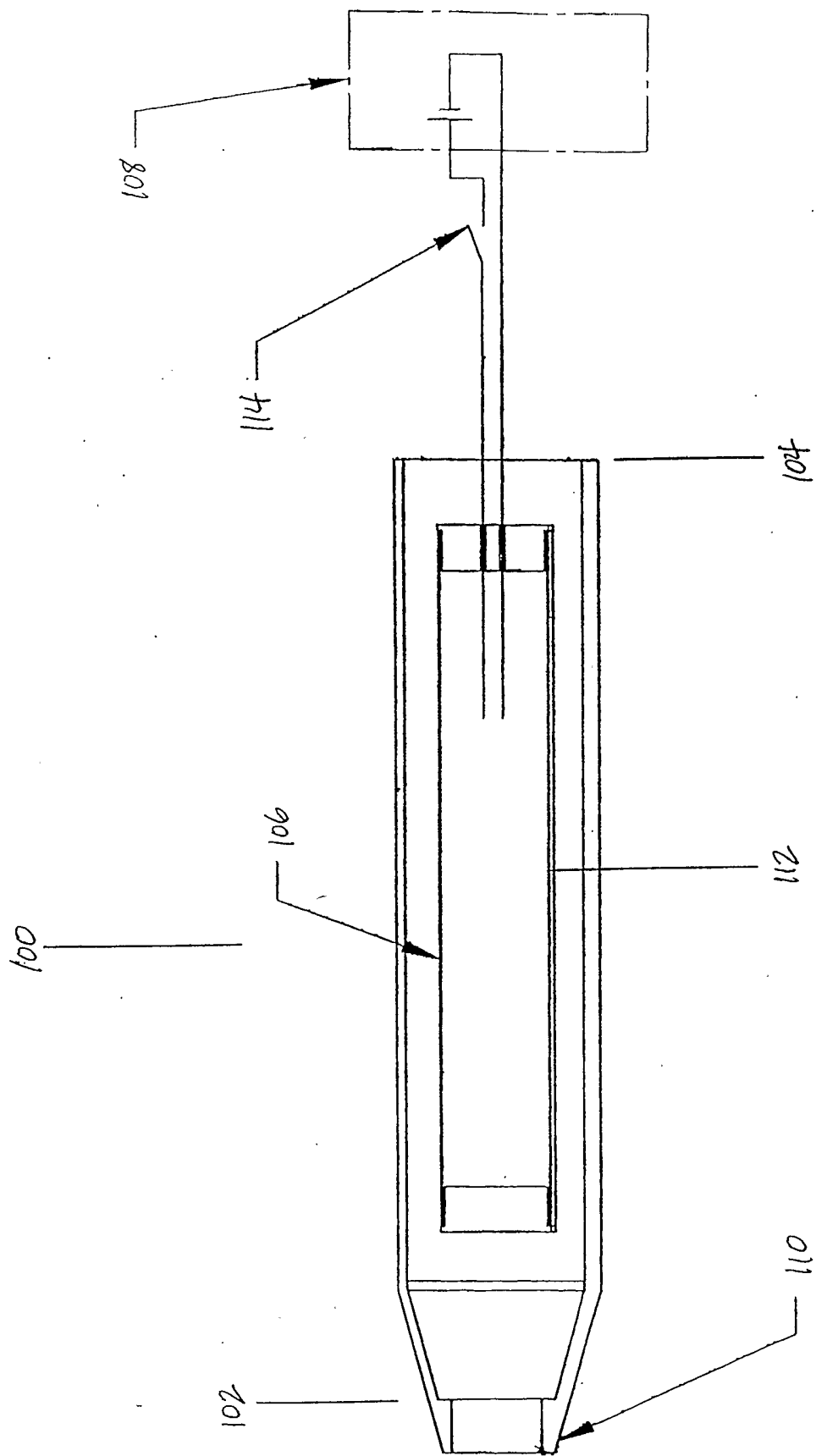

**Fig. 1**

INTERNATIONAL SEARCH REPORT

International Application No  
PCT/US 02/37489

A. CLASSIFICATION OF SUBJECT MATTER  
IPC 7 A61K9/00 A61K31/52

According to International Patent Classification (IPC) or to both national classification and IPC

B. FIELDS SEARCHED

Minimum documentation searched (classification system followed by classification symbols)  
IPC 7 A61K

Documentation searched other than minimum documentation to the extent that such documents are included in the fields searched

Electronic data base consulted during the international search (name of data base and, where practical, search terms used)

WPI Data, PAJ, CHEM ABS Data

C. DOCUMENTS CONSIDERED TO BE RELEVANT

Category °	Citation of document, with indication, where appropriate, of the relevant passages	Relevant to claim No.
A	US 5 525 329 A (S.H.SNYDER ET AL.) 11 June 1996 (1996-06-11) claims column 4, line 40 - line 63 ---	1-15
A	DATABASE WPI Section Ch, Week 198941 Derwent Publications Ltd., London, GB; Class B07, AN 1989-297792 XP002230849 & JP 01 221313 A (NIPPON CREATE KK), 4 September 1989 (1989-09-04) abstract --- -/--	1-15



Further documents are listed in the continuation of box C.



Patent family members are listed in annex.

° Special categories of cited documents :

- \*A\* document defining the general state of the art which is not considered to be of particular relevance
- \*E\* earlier document but published on or after the international filing date
- \*L\* document which may throw doubts on priority claim(s) or which is cited to establish the publication date of another citation or other special reason (as specified)
- \*O\* document referring to an oral disclosure, use, exhibition or other means
- \*P\* document published prior to the international filing date but later than the priority date claimed

- \*T\* later document published after the international filing date or priority date and not in conflict with the application but cited to understand the principle or theory underlying the invention
- \*X\* document of particular relevance; the claimed invention cannot be considered novel or cannot be considered to involve an inventive step when the document is taken alone
- \*Y\* document of particular relevance; the claimed invention cannot be considered to involve an inventive step when the document is combined with one or more other such documents, such combination being obvious to a person skilled in the art.
- \* & \* document member of the same patent family

Date of the actual completion of the international search

12 March 2003

Date of mailing of the international search report

26/03/2003

Name and mailing address of the ISA

European Patent Office, P.B. 5818 Patentlaan 2  
NL - 2280 HV Rijswijk  
Tel. (+31-70) 340-2040, Tx. 31 651 epo nl,  
Fax: (+31-70) 340-3016

Authorized officer

Scarponi, U

## INTERNATIONAL SEARCH REPORT

International Application No  
PCT/US 02/37489

C.(Continuation) DOCUMENTS CONSIDERED TO BE RELEVANT		
Category °	Citation of document, with indication, where appropriate, of the relevant passages	Relevant to claim No.
A	GB 903 866 A (P.R.L. GIUDICELLI ET AL.) 22 August 1962 (1962-08-22) claims example II page 2, line 24 - line 27 ---	1-15
A	WO 01 80829 A (BRISTOL-MEYERS SQUIBB) 1 November 2001 (2001-11-01) examples page 14, line 16 claims ---	1-15
A	WO 01 41732 A (S.L.GORE) 14 June 2001 (2001-06-14) claims 1,7,22,40,64,67,94,118,133,151,175 ---	1-15
A	WO 01 13957 A (CELLGATE) 1 March 2001 (2001-03-01) claims 1,33,54,66,67,74,75,78 page 32, line 2 - line 3 page 33, line 9 - line 10 page 38, line 7 - line 10 -----	1-15

# INTERNATIONAL SEARCH REPORT

International application No.  
PCT/US 02/37489

## Box I Observations where certain claims were found unsearchable (Continuation of item 1 of first sheet)

This International Search Report has not been established in respect of certain claims under Article 17(2)(a) for the following reasons:

1.  Claims Nos.:  
because they relate to subject matter not required to be searched by this Authority, namely:  

Although claims 9-12 are directed to a method of treatment of the human/animal body, the search has been carried out and based on the alleged effects of the compound/composition.
2.  Claims Nos.:  
because they relate to parts of the International Application that do not comply with the prescribed requirements to such an extent that no meaningful International Search can be carried out, specifically:
3.  Claims Nos.:  
because they are dependent claims and are not drafted in accordance with the second and third sentences of Rule 6.4(a).

## Box II Observations where unity of invention is lacking (Continuation of item 2 of first sheet)

This International Searching Authority found multiple inventions in this international application, as follows:

1.  As all required additional search fees were timely paid by the applicant, this International Search Report covers all searchable claims.
2.  As all searchable claims could be searched without effort justifying an additional fee, this Authority did not invite payment of any additional fee.
3.  As only some of the required additional search fees were timely paid by the applicant, this International Search Report covers only those claims for which fees were paid, specifically claims Nos.:
4.  No required additional search fees were timely paid by the applicant. Consequently, this International Search Report is restricted to the invention first mentioned in the claims; it is covered by claims Nos.:

### Remark on Protest

- The additional search fees were accompanied by the applicant's protest.
- No protest accompanied the payment of additional search fees.

# INTERNATIONAL SEARCH REPORT

Information on patent family members

International Application No

PCT/US 02/37489

Patent document cited in search report	A	Publication date	Patent family member(s)	Publication date
US 5525329	A	11-06-1996	NONE	
JP 1221313	A	04-09-1989	NONE	
GB 903866	A	22-08-1962	NONE	
WO 0180829	A	01-11-2001	AU 5550901 A EP 1276469 A2 WO 0180829 A2	07-11-2001 22-01-2003 01-11-2001
WO 0141732	A	14-06-2001	AU 1261501 A WO 0141732 A1 CA 2325106 A1	18-06-2001 14-06-2001 06-06-2001
WO 0113957	A	01-03-2001	AU 6939400 A EP 1210121 A2 WO 0113957 A2 US 2003022831 A1 US 2002127198 A1	19-03-2001 05-06-2002 01-03-2001 30-01-2003 12-09-2002