

(19) **DANMARK**

(10) **DK/EP 3488065 T3**



Patent- og  
Varemærkestyrelsen

(12) **Oversættelse af  
europæisk patentskrift**

- 
- (51) Int.Cl.: **E 06 B 1/70 (2006.01)** **E 06 B 3/46 (2006.01)**
- (45) Oversættelsen bekendtgjort den: **2020-06-22**
- (80) Dato for Den Europæiske Patentmyndigheds bekendtgørelse om meddelelse af patentet: **2020-04-01**
- (86) Europæisk ansøgning nr.: **17726311.8**
- (86) Europæisk indleveringsdag: **2017-05-30**
- (87) Den europæiske ansøgnings publiceringsdag: **2019-05-29**
- (86) International ansøgning nr.: **EP2017062949**
- (87) Internationalt publikationsnr.: **WO2018015053**
- (30) Prioritet: **2016-07-22 DE 202016004456 U**
- (84) Designerede stater: **AL AT BE BG CH CY CZ DE DK EE ES FI FR GB GR HR HU IE IS IT LI LT LU LV MC MK MT NL NO PL PT RO RS SE SI SK SM TR**
- (73) Patenthaver: **Siegenia-Aubi KG, Industriestrasse 1-3, 57234 Wilnsdorf, Tyskland**
- (72) Opfinder: **BERENS, Wolfgang, Messflur 20, 54427 Kell am See, Tyskland**
- (74) Fuldmægtig i Danmark: **Patrade A/S, Ceresbyen 75, 8000 Århus C, Danmark**
- (54) Benævnelse: **BUNDSTYKKESYSTEM TIL EN FORSKYDELIG FLØJ SOM SKYDEFLØJ ELLER FORSKYDELIG HÆVE-SKYDEFLØJ PÅ ET VINDUE ELLER EN DØR**
- (56) Fremdragne publikationer:  
**DE-A1-102007 003 904**



**Ground sill system for a movable leaf as sliding leaf or slidable lift-and-slide leaf of a window or door**

The invention relates to a ground sill system for a movable leaf as a sliding leaf or slidable lift-and-slide leaf of a window or a door in accordance with the preamble to claim 1.

5

Movable leaves as sliding leaves or slidable lift-and-slide leaves of a window or door are known in the most widely differing configurations, and in the simplest case consist of a leaf, arranged in an outer frame so as to be movable for opening and closing, as a sliding leaf, and a further door or window elements, such as a fixed section, likewise arranged in the frame.

10

The closed movable leaf can be locked to the frame on its side facing away from the further door or window element by the actuation of a fitting provided in the leaf frame, and therefore secured against unauthorised opening. Sliding leaves are, as a rule, mounted so as to be movable above or below the leaf. On opening, as a rule with an actuating handle, of lift-and-slide leaves, the leaf is raised with seals, as a result of which it runs more easily on the ground sill system. The opened leaf can then be moved in front of a fixed section located next to it. Depending on the configuration, lift-and-slide leaves may only slide, or may in addition also tilt. On closing, the movable leaf is lowered onto the ground sill system, and the seals are therefore again pressed into contact. Opening and closing is also possible by means of electrical, hydraulic, or pneumatic actuators.

20

Such ground sills and moving elements are known.

Sliding elements are known as sliding doors, sliding windows, or balcony elements. The problem with the known sliding elements is that, because of the guide elements necessary for the movable leaf or leaves, in particular in the horizontal lower region of the ground sill system, a barrier-free transition is not possible, since the rollers necessary for the sliding doors, sliding windows, or balcony elements are guided on guide webs or roller guides, which project from the ground sill. In particular with what are known as old sills, which do not have any floor recess, it is a matter of concern these may only exhibit a limited height for barrier-free transitions, but the guide for the leaf rollers in these old sills project over the sills, and can only be integrated into the sill with extreme difficulty.

30

A further disadvantage of the known ground sill systems is their poor water removal system. In the sensitive passage region of the sliding leaf, the water which flows out under wind pressure is again pressed against the known sealing system of the sliding leaf, and in extreme weather situations penetrates into the interior of the room space.

35

In addition to this, the ground sill systems with a transition to the upper edge of the floor in the

interior of the room space and/or on the outer side of the room space form an offset, which together with the projecting guide web for the running rollers, can likewise have the effect of a tripping edge.

- 5 A known device is described in EP 0657610 A2 or in DE 10 2007 003 904 A1. In that situation, a ground sill made of metal is proposed for the frames of sliding or lifting-sliding windows and doors, which has a running rail which comprises a guide web for the running rollers of running carriages arranged on the leaf side. A guide web is formed secured directly or as one piece, i.e. of uniform material, on the upper side of the ground sill, wherein this guide web exhibits
- 10 undercuts over its entire length towards the upper side of the ground sill, such that, if required, a running rail hollow profile provided on its underside with a longitudinal gap, and carrying a guide web on its upper side, can be locked in engagement directly with the undercuts on the guide web of the ground sill.
- 15 Further known from DE 20 2004 005 204 U1 is a frame construction of the sliding door. The leafs comprise in each case a glazing element, which is carried by a leaf frame. On the lower frame transverse profile of the movable leaf, a longitudinal cut-out opening of the leaf frame serves to accommodate pairs of rollers, which, during the sliding movement of the movable leaf, run between its leaf frame and a roller support profile of the ground sill profile. The lower frame
- 20 transverse profile of the fixed-frame leaf is supported by a support profile on the ground sill profile. The frame profile of the fixed-frame leaf is secured to the support profile by a plurality of securing screws. Located in each case between the leaf frame and the support profiles are a pair of leaf seal profiles, which seal the leaf frame against the ground sill profile.
- 25 The known devices likewise require a guide web in order to implement a secure roller guide arrangement for the running rollers on the sliding frame. The known guide webs project over the ground sill system, and in other design variants extend the ground sill system still further, such that, with the addition of further guide web, the device becomes far removed from a barrier-free system, and an even larger potential tripping edge develops.
- 30
- The invention is based on the object of providing a functionally reliable and compact ground sill system for a movable leaf as a sliding leaf or slidable lift-and-slide leaf of a window or a door, which avoids the disadvantages described, i.e. creates barrier-free transitions, improves water clearance and tightness against driving rain, and, while providing for a satisfactory appearance
- 35 of the window or door, is economical and can be fitted and adjusted in a simple, rapid, reliable, and precise manner, with only a small structural space required.

To solve this object, a sliding leaf or lift-and-slide leaf of a window or a door comprises a ground sill system. To accommodate a guide web, an accommodation slot is provided in a ground sill profile. The guide web forms a running rail, which comprises running rollers for running  
5 opposite the sliding leaf, and engages over its entire length in the accommodation slot, guided in positive or non-positive fit. Preferably, an adapter profile is allocated to the ground sill system, which, with convex-shaped connection means on its under side, can engage into the accommodation slot of the ground sill profile in positive or non-positive fit, and the adapter  
10 profile interacts with the ground sill profile such as to be functionally connected. On the upper side of the adapter profile, opposite the under side, an accommodation slot is provided, which equates to the accommodation slot of the ground sill profile and is suitable for accommodating the guide web as one piece, i.e. of uniform material, or divided in two, wherein the guide web forms with the upper edge of the running rail forms, together with the upper side of the adapter  
15 profile, a flush-surface barrier-free contact. Due to a contact of the adapter profile on the ground sill profile in a manner which forms a shoulder, a visible contact surface is formed on the respective sides of the adapter profile, on which can be laid an inner base surface towards the inner space side of the window or door, and, towards the outer space side, optionally different widening profiles for the transition to the outer base surface, preferably for barrier-free  
20 transitions.

25 In order to create an even surface which will not induce tripping, it is of advantage for the guide web to be let into the accommodation slot of the adapter profile, and to terminate in flush contact with the upper side, wherein the height of the accommodation slot corresponds to the height of the guide web.

30 To put the advantages described above into effect, the adapter profile adapts with the ground sill profile and forms a modular structural unit. The ground sill profile can be fixed to the adapter profile in positive fit, and can be coupled in non-positive fit by means of a locking/snap connection or by additional securing elements, such as securing screws. Due to the type of the  
35 connection, a high sealing effect is achieved, and prevents the possible penetration of water due to wind loads and driving rain.

In order to improve the existing appearance of the window or door, and to achieve simple and economical production, the configuration and distance intervals in the cross-section of the  
40 adapter profile, in width and height, can be selected such as to match with differently configured widening profiles, wherein the adapter profile can be variably separated in width and is covered by the sliding leaf. The ground sill system can therefore be universally mounted on and adjusted to the most widely differing widening profiles from different system manufacturers. In order to

simplify separation, prefabricated separation joints can be provided in the adapter profile, which allow for a folding movement followed by separation, or which can be used as a visible edge as an aid to cutting.

- 5 A stable and effectively sealing connection of the adapter profile with the ground sill profile, and a variant which in terms of manufacturing technique is both simple and economical, can be attained in that the connection means is formed in cross-section as angular, extending over the length of the ground sill profile, and engages over the length of the ground sill profile. Also possible are connection means which are divided into several sections, although at the expense  
10 of the advantages described heretofore.

- A simple assembly and secure retention of the adapter profile on the ground sill profile with simple and economical means is advantageously achieved in that the connection means are configured for a snap locking connection and/or by means of additional securing means,  
15 engaging securely into the accommodation slot of the ground sill profile.

- In order to put the foregoing advantages into effect, the adapter profile is produced from a full material or full profile, for example from wood or from any desired load-bearing material, e.g. marble, or is configured as a hollow chamber profile, consisting of an extruded profile of plastic  
20 or aluminium.

- As a result of the seals which are arranged over the entire length of the adapter profile, on the under side between the ground sill profile on the respective sides of the connection means, which are advantageously convex extruded onto the adapter profile, a high sealing effect is  
25 achieved against the possible penetration of water due to wind loadings and driving rain. They also compensate for tolerances between the connection of the adapter profile and the ground sill profile, and have a supportive effect due to pressing behaviour onto the seat of the connection.

- 30 An advantageous further embodiment can further be seen in that the adapter profile with the ground sill profile causes a change in the overall height of the ground sill system, and extends over a length of the frame, as a result of which, laterally in the cross-section of the adapter profile, and at least over the length of the respective inner sides of the vertical spars, additional contact surfaces are formed, which provide space for the positioning of further widening profiles  
35 which can be connected in combinations, and which can be placed such as to be adjusted to the width of the ground sill system. The dimension of the overall height can be defined such as to match the shaping and functional performance of the adapter profile and/or as a dependency of the configuration of the widening profiles.

Particularly advantageous is the fact that the widening profile on the outer space side is a water discharge grille. In this situation, the water discharge grille comprises a mounting body with cut-out regions which correspond to the water discharge, which are configured in different patterns, for example as longitudinal webs running parallel to the adapter profile, as transverse webs  
5 running towards the adapter profile, or are formed as perforated or angular webs. The mounting body is stably supported on spacer profile blocks positioned at a distance from one another, which themselves lie on the ground sill profile, inclined at angle in the direction of the outer space side. Due the cavity formed in the spacer profile blocks between the ground sill profile and the mounting body, a gully body is formed, such that undesirable water can be conveyed  
10 away before possible penetration, or water which has already penetrated can be automatically conveyed over the surface of the ground sill profile inclined towards the outer space side, away from the window or door. In addition, water which penetrates into the rebate space can also be conveyed away by way of water removal cut-out openings or holes in the rebate space between the adapter profile and sliding leaf, going outwards from the accommodation slot of the adapter  
15 profile running at an inclined angle in the direction of the widening profile.

Due to the direct contact between the water discharge grille and the adapter profile, water which has penetrated into the rebate space can preferably also be conveyed out onto the outer space side covered over.

20 In order to put the foregoing advantages into effect, the widening profile extends in the length from the closure side vertical frame spar of the door or window frame as far as the fixed section frame, which approximates to the opening width of the window or door. Furthermore, the widening profile, in the cross-section in the direction towards the inner space side, is  
25 advantageously in flush surface contact with the adapter profile, and forms in the direction towards the outer space side a flush surface contact with the outer floor surface. Accordingly, the widening profile or the water discharge grille covers the entire opening range of the sliding leaf of the window or door, such that water which might possibly penetrate in the opening range of the sliding leaf can already, with simple means, run off reliably and without any problem from  
30 the outer space side, and still with good appearance, by adaptation to a barrier-free flat floor surface.

A functional extension of the adapter profile in respect of increasing security against the possibility of water penetration, which potentially can collect in the ground sill profile, is put into  
35 effect in that the adapter profile comprises water discharge cut-outs or boreholes, which run at an inclined angle starting from the accommodation slot of the adapter profile or the rebate space of the ground sill system to the sliding leaf, towards the outer space side, in the direction of the widening profile or water discharge grille. Preferably, the water discharge cut-outs or

boreholes open on a contact surface of the adapter profile in a manner which cannot be seen, and therefore covered, into the region of the water discharge grille, wherein the water can run off from the rebate space of the ground sill system, as well as the remaining water present on the outer space side, on the ground sill profile inclined at an angle towards the outside.

5

The object of the invention is also solved by a sliding element, in particular a sliding leaf or lift-and-slide leaf of a window or door, with a ground sill system. In this situation, a ground sill profile comprises an accommodation slot for a guide web for the running rollers of running rails comprising leaf-side carriages, which is arranged on the upper side of ground sill profile, 10 opposite the sliding leaf, to accommodate the guide web. The guide web can be inserted over its entire length into the accommodation slot, with positive or non-positive fit. Likewise, an adapter profile can preferably also be introduced into the accommodation slot. For this purpose, the adapter profile comprises on its under side an appropriately fitted connection means, which is adapted to the shaping of the accommodation slot of the ground sill profile. Depending on the 15 configuration, the adapter profile can be connected in positive or non-positive fit, by means of a locking engagement/snap connection or by securing screws, into the accommodation slot of the ground sill profile. In addition, on the side facing away from the connection means, the adapter profile preferably comprises, on an upper side opposite an axis, an accommodation slot, which approximates to the accommodation slot of the ground sill profile. In order to accommodate the 20 running rail secured to the sliding leaf, comprising running carriages for the running rollers, the accommodation slot of the adapter profile accommodates the guide web. With the placing of the adapter profile onto the ground sill profile, corresponding contact surfaces are formed on the respective sides, which are used for the contacting and positioning of different widening profiles. The adapter profile and the widening profiles form themselves, and with the floor surfaces of the 25 inner space side and the outer space side, a flush-surface and flat transition point.

In addition, it has proved advantageous with regard to the function, assembling, and costs of the fitting, if the adapter profile can be fitted independently of the fitting of the actuation linkage and independently of the production of the window or the door. The fitting of the adapter profile horizontally between the sliding leaf and the fixed section or frame is possible. Also conceivable 30 are a plurality of adapter profiles being used, arranged above one another, which can be centred with one another in the respective accommodation slot.

Further advantageous embodiments derive from the drawings. These show:

35 Fig. 1 A front view, represented from the inner space side, of a window or a door, with a sliding leaf in the closed state, with a fixed section at the frame, and a ground sill system of the sliding leaf and the fixed section arranged at the lower horizontal frame,

- 5 Fig. 2 a vertical section through the sliding leaf region corresponding to the section A-A of the window or door according to Fig. 1, on which the closed sliding leaf lies on an adapter profile with a guide web of the ground sill system, and with a water discharge grille, likewise represented in section and arranged at the outer space side,
- Fig. 3 a vertical section through the sliding leaf region corresponding to the section B-B of the window or door according to Fig. 1, with a fixed section and an adapter profile arranged on the ground sill system, with a guide web for moving the sliding leaf,
- 10 Fig. 4 a vertical section through the sliding leaf region corresponding to the section A-A of the window or door according to Fig. 1, with a second embodiment variant, on which the closed sliding leaf lies on an adapter profile of the ground sill system, and with a water discharge grille, likewise represented in section, facing towards the outer space side,
- 15 Fig. 5 a vertical section through the sliding leaf region corresponding to the section B-B of the window or door according to Fig. 1, with a second embodiment variant according to Fig. 4, with a fixed section and an adapter profile arranged on the ground sill system, with a guide web for moving the sliding leaf,
- 20 Fig. 6 a ground sill profile of a ground sill system with an adapter profile in a vertical section, with a borehole or a cut-out represented for the removal of water which could potentially penetrate into the rebate space of the window or door,
- Fig. 7 a perspective representation of the ground sill system from the inner space side, with an adapter profile and guide web positioned thereon, and in contact with a water discharge grille arranged at the adapter profile of a flat barrier-free transition at the lower horizontal region of the window or door,
- 25 Fig. 8 a perspective representation of the ground sill system from the outer space side, with an adapter profile and guide web positioned thereon, and a water discharge grille in contact with the adapter profile, forming a gully body, of a flat, barrier-free transition at the lower horizontal region of the window or door,
- 30 Fig. 9 a perspective section of the window or door according to Fig. 1 of the lower horizontal region, with a ground sill system, from the outer space side, with a

water discharge grille according to Fig.7 lying on distance spacer blocks and a gully body formed thereby, and

Fig. 10 a front view and a view from above of the ground sill system, without a frame, sliding leaf, and fixed section.

- 5 The window or door designated in the Figures by 1 consists essentially of an outer post or panel frame 2, in which a movable leaf for opening and closing the door 1 and a fixed section 4 are provided. According to Fig. 1, an arrow characterizes the path for the opening of the sliding leaf 3.
- 10 The leaf 3, which is configured as a lift-and-slide leaf, comprises, among other elements, the leaf frame 5 and the glazing element 6 provided in this frame. The fixed section 4 consists essentially of the frame 7 and the associated glazing element 8.

15 With the sliding leaf 3 according to Fig. 1, this is locked by locking elements engaging on the vertical spar of the panel frame 2, of a fitting, not shown, provided on the leaf frame 5 of the sliding frame 3. On the side facing away from the fixed section 4, the vertical spar of the leaf frame 5 of the sliding leaf 3, overlapping in the joint region of the fixed section frame 7 forming the transition, is locked by further locking elements, not represented.

- 20 In addition, in Fig. 1 a ground sill system 9 is arranged in the lower horizontal region of the window or door 1. Corresponding sectional representations A-A and B-B in Fig. 1 characterize the ground sill system 9 of a sliding leaf 3 or slidable lift-and-slide leaf in further Figures 2 to 5. The ground sill system 9 shown in Figs. 1 to 10 is configured, for example, as a thermally-separated ground sill, and composed of a plurality of connection profiles. In this situation,
- 25 tubular or box profiles can be manufactured from metallic material, in particular aluminium, by extrusion, or consist of stable-form and rot-resistant plastic material, and produced as profiles in an extrusion process. The ground sill system 9, in particular the ground sill profile 11, can of course also consist entirely of metallic material, predominantly aluminium, and can be manufactured by extrusion as one piece, or from a plastic material with metallic profile inserts.
- 30 Finally, it is also possible, instead of a ground sill profile 11, for a cover profile of metal or plastic to be used, which does not exhibit a tubular or box-shaped cross-section, but is configured as relatively flat and open downwards, and which in this case can be secured on the lower horizontal spar of the panel frame 2 made of wood or also plastic.

- 35 All the embodiments described heretofore of ground sill profiles 11 and cover profiles as shown in Figures 2 to 5 can be connected to a base profile 40 to form a structural unit. Panel frames 2,

which are structured with ground sill systems 9 in accordance with systems described heretofore are in practical use as slidable lift-and-slide leaf windows and doors 1, and extend in the lower horizontal region over the entire length of the window or door 1. For this purpose, the ground sill systems 9 according to Figures 2 to 8 are provided with at least one guide web 12 for the grooved running rollers 13 of running rails 15, comprising leaf-side running carriages 14. Depending on the purpose of use of the slidable lift-and-slide leaf windows and doors, it may be necessary in this situation for various different design forms of running rails 15 to be used. Preferred in this situation are running rails 15 which are designed for ground sill systems 9 which are suitable for disabled persons, i.e. which in particular can be crossed by wheelchairs, and are formed as relatively flat and therefore have a flat running rail 15.

A ground sill system 9 with a flat and barrier-free surface followed by a flat transition region to the floor level leading to the inner space side 23 and to the outer space side 25, and which fulfils all the requirements in respect of sealing tightness and safety when lifted, is solved hereinafter by a sliding leaf 3 or slidable lift-and-slide leaf of a window or door 1. For this, according to Figs. 2 to 8, an accommodation slot 10 is provided to accommodate the guide web 12 on the ground sill profile 11. The running rail 15 carrying the guide web 12, which is arranged on the upper side of the ground sill profile 11 opposite the sliding leaf 3, engages, not shown, over its entire length in the accommodation slot 10, being guided in positive or non-positive fit. According to a further embodiment variant, an adapter profile 16 is provided at the ground sill system 9, which engages in positive and/or non-positive fit, with convex-shaped connection means 18 on its under side 17, in the accommodation slot 10 of the ground sill profile 11, and interacts in function with the adapter profile 16. For this purpose, the guide web 12, previously in engagement, is removed from the accommodation slot 10, or the accommodation slot 10 is shaped in such a way that the connection means 18 can be accommodated despite the guide web 12 being present.

According to Figures 2 to 8, an accommodation slot 20 is provided on the upper side 19, opposite the under side 17, of the adapter profile 16, which equates to the accommodation slot 10 of the ground sill profile 11, and is capable of accommodating the guide web 12 as one piece, i.e. made of uniform material, or divided in two parts, wherein the guide web 12, with upper edge running rails 15, forms together with the upper side 19 of the adapter profile 16 a flush barrier-free contact. Due to the shoulder formed by the adapter profile 16 lying on the ground sill profile 11, a visible contact surface 21, 22 is formed on the respective sides of the adapter profile 16, connected to which is an inner floor surface 24, leading to the inner space side 23 of the window or door 1, and on which, leading to the outer space side 25, optionally, different widening profiles 26, 27 can be laid to provide the transition to the outer floor surface 28 for barrier-free crossing. The height of the contact surfaces 21, 22 can be determined by the

shaping of the adapter profile 16, and are delimited in length by the respective vertical spars of the panel frame 2. According to Figures 2 to 8, the contact surfaces 21, 22 of the adapter profile 16 are aligned vertically, extending without any transition points into the outer dimensions of the sliding leaf 3. Depending on the configuration of the adapter profile 16, with a differing width 29, a shoulder can be formed to the sliding leaf 3, such that the contact surfaces 21, 22 are displaced accordingly for the widening profiles 26, 27. In terms of design, not represented, a reduced width 29 of the adapter profile 16 has the effect, for example, of displacing the water discharge grille 34 under the sliding leaf 3.

10 According to Figures 2 to 8, the guide web 12 is let into the accommodation slot 20 of the adapter profile 16 and comes in flush contact with the upper side 19, wherein the height of the accommodation slot 20 corresponds to the height of the guide web 12.

The adapter profile 16 adapts, according to Figures 2 to 8 with the ground sill profile 11, and forms an integral structural unit. For this purpose, the ground sill profile 11 can be fixed in positive fit to the adapter profile 16, and can, by means of a locking engagement/snap connection or by additional securing elements, such as securing screws, be connected to it in non-positive fit. Due to the type of the connection, a high sealing effect is achieved, and the possible penetration of water due to wind load and driving rain is prevented.

20 The cross-section dimensions of the adapter profile 16 in width 29 and height 30 can be selected so as to accord with differently configured widening profiles 26, 27. For this purpose, the adapter profile 16 can be variably separated in the width 29. In addition, the adapter profile 16 is covered full-surface in the width 29 by the sliding leaf 3. Depending on the embodiment variant, the adapter profile 16 is configured in the width 29, not represented, depending on the different configurations, as less than that of the sliding leaf 3, such that, for example, the contact surface 22 is configured as offset, and the widening profile 26 projects under the sliding leaf 3. Accordingly, the ground sill system 9 can be universally mounted and adjusted on the most widely differing widening profiles from different system manufacturers. For easier separation in the longitudinal direction of the adapter profile 16, prefabricated separation joints, not represented, can be provided in the adapter profile 16, which allow for the folding and subsequent separation of individual part sections in order to allow for the reduction of the width of the adapter profile 16, or are used as visible edges or or assistance for cutting with the same purpose.

35 A tight-sealing and stable connection of the adapter profile 16 with the ground sill profile 11 is provided by the connection means 18, which is shaped as angular in cross-section and extends over the length of the adapter profile 16. For this purpose, according to Figures 2 to 8, webs 39

are arranged at the connection means 18, which project in the direction of the ground sill profile 11, which engage in a stable form into the cut-out opening 10 of the ground sill profile 11.

- 5 Easy assembly and secure retention of the adapter profile 16 on the ground sill profile 11 is advantageously achieved with simple and economical means in that the connection means 18 is configured for a lock engagement connection and/or by means of additional securing means, not represented, such as securing screws, such as to be secured engaging into the accommodation slot 10 of the ground sill profile 11.
- 10 The adapter profile 16 can in this situation be made of a full material or full profile, for example of wood or from any desired load-bearing material, such as marble. According to Figures 2 to 8, the adapter profile 16 is configured as a hollow chamber profile, and made of a plastic or from aluminium as an extrusion profile.
- 15 By means of seals 31, 32, according to Figures 2 to 8, which are extruded convex over the entire length of the adapter profile 16, on the under side 17 of the adapter profile 16, immediately next to the connection means 18 between the ground sill profile 11, a high sealing effect is achieved against the possible penetration of water due to wind loads and driving rain. They also compensate for tolerances between the connection of the adapter profile 16 and the
- 20 ground sill profile 11 and provide support by exerting a pressing effect on the seat of the connection.

- It can be seen in Figures 2 to 8 that the adapter profile 16 has the effect with the ground sill profile 11 of causing a change in the overall height 33 of the ground sill system 9, and extends
- 25 over a length of the respective inner sides of the vertical spars, or, not represented, over the length of the entire panel frame 2. In this situation, additional contact surfaces 21, 22, are formed laterally in the cross-section of the adapter profile 16, which provide space for the positioning of further widening profiles 26, 27, which can be connected and combined, and which can be inserted as adapted to the width of the ground sill systems 9. The dimension of
- 30 the overall height 33 can be defined to match the shape and function of the adapter profile 16 and/or as a dependency of the configuration of the widening profiles 26, 27.

- According to Figures 2 to 10, it is clear that the widening profile 26 on the outer space side 25 is a water discharge grille 34. In this situation, the water discharge grille 34 comprises a mounting
- 35 body 35 with corresponding cut-outs for water discharge, which are configured in different patterns, for example as longitudinal webs, located parallel to the adapter profile 16, as represented in Figures 2 to 10, or as webs aligned transverse to the adapter profile 16 and to the direction of displacement of the sliding leaf 3, or formed as perforated or angular webs. The

mounting body 35 is supported in a stable manner on spacer profile blocks 36, arranged at a distance from one another, which themselves lie on the surface 41 of the ground sill profile 11, inclined in the direction of the outer space side 25. The number of spacer profile blocks 36 is determined depending on the type and length of the window or door 1. As shown in Figure 8 to 10, two spacer profile blocks 36 are used. Due to the spacer profile blocks 36, between the ground sill profile 11 and the mounting body 35 a cavity is created, which forms a gully body 37, such that unwanted water can be automatically conveyed away before possible penetration, or water which has already penetrated can be removed over the surface 41 inclined towards the outer space side of the ground sill profile 11, away from the window or door 1.

10

In addition, water which has penetrated into the rebate space of the window or door 1 can be conducted away from the window or door 1 through water discharge cut-outs or boreholes 38, to the outer space side 25. For this purpose, the adapter profile 16 comprises water discharge cut-outs or boreholes 38, which run at an inclined angle starting from the accommodation slot 20 to the outer space side 25, in the direction of the widening profile 26. Due to the direct contact of the water discharge grille 34 at the adapter profile 16, water which has penetrated into the rebate space can also be transported away covered, to the outer space side 25.

15

According to Figures 9 and 10, the widening profile 26 or the water discharge grille 34 extends in the length from the closure-side vertical frame spar of the panel frame 2 as far as the fixed section frame 5, which approximates the opening width of the window or door 1. In addition, the widening profile 26 is in flush surface contact in cross-section, in the direction towards the inner space side 23, with the adapter profile 16, and in the direction of the inner space side 25 forms a flush contact with the outer floor surface 28. Accordingly, the widening profile 26 or the water discharge grille 34 cover the entire opening range of the sliding leaf 3 of the window or door 1, such that water which might penetrate in the opening range of the sliding leaf 3 can already run off reliably and without any problem, by simple means and visually advantageously by adjustment of the outer space side 25 to a barrier-free flat floor surface.

20

25

Shown in Figures 1 to 10 is a displacement element, in particular a slidable lift-and-slide leaf 3 of a window or door 1 with a ground sill system 9. In this situation, a ground sill profile 11 comprises an accommodation slot 10 for a guide web 12 for running rails 15, which comprise the running rollers 13 of leaf-side running carriages 14, which is formed on the upper side of the ground sill profile 11, opposite the sliding leaf 3, to accommodate the guide web 12. The guide web 12 can be inserted over its entire length in positive or non-positive fit into the accommodation slot 10.

30

35

According to Figures 2 to 8, an adapter profile 16 can likewise be introduced into the accommodation slot 10. For this purpose, the adapter profile 16 comprises on its under side 17 a connection means 18, arranged as elevated, which is adapted to the shape of the accommodation slot 10 of the ground sill profile 11. Depending on the configuration, the adapter profile 16 can be connected in positive or non-positive fit, by means of a locking engagement or snap connection or by securing screws, into the accommodation slot 10 of the ground sill profile 11. In addition, the adapter profile comprises, on the side of the connection means 18 facing away, preferably on an upper side 19 opposite an axis, an accommodation slot 20, which equates to the accommodation slot 10 of the ground sill profile 11. In order to accommodate the running carriages 14, secured to the sliding leaf 3, for the running rails 15 comprising the running rollers 13, the accommodation slot 20 of the adapter profile 16 accommodates the guide web 12. Due to the location of the adapter profile 16 on the ground sill profile 11, corresponding contact surfaces 21, 22 are formed on the corresponding sides, which are used for the locating and positioning of different widening profiles 26, 27. The adapter profile 16 and the widening profiles 26, 27 form themselves, and with the floor surface 24 of the inner space side 23 and the floor surface 28 of the outer space side 25, a flush surfaced and flat transition region.

**Reference number list**

	1	Window or door
	2	Panel frame
5	3	Sliding leaf
	4	Fixed section
	5	Leaf frame
	6	Glazing element
	7	Fixed section frame
10	8	Glazing element
	9	Ground sill system
	10	Accommodation slot
	11	Ground sill profile
	12	Guide web
15	13	Running roller
	14	Running carriage
	15	Running rail
	16	Adapter profile
	17	Under side
20	18	Connection means
	19	Upper side
	20	Accommodation slot
	21	Contact surface
	22	Contact surface
25	23	Inner space side
	24	Floor surface
	25	Outer space side
	26	Widening profile
	27	Widening profile
30	28	Floor surface
	29	Width
	30	Height
	31	Seal
	32	Seal
35	33	Overall height
	34	Water discharge grille
	35	Mounting body
	36	Spacer profile block

	37	Gully body
	38	Water discharge cut-out/water discharge borehole
	39	Web
	40	Base profile
5	41	Surface

## Patentkrav

1. Bundstykkessystem (9) til en forskydelig fløj som skydefløj (3) eller forskydelig hæve-skydefløj på et vindue eller en dør (1), med en optagenot (10) i en bundstykkeprofil (11) i bundstykkessystemet (9) til optag af en føringsholder (12) til kørehjulene (13) på en køreskinne (15) med ruller (14) på fløjsiden, hvilken optagenot er anbragt på oversiden af bundstykkeprofilen (11) over for skydefløjen (3), hvor føringsholderen (12) i hele sin længde kan gribe form- og/eller kraftssluttende ind i optagenoten (10), **kendetegnet ved, at** der er tilvejebragt mindst en adapterprofil (16), som med en på sin underside (17) konveks konfigureret forbindelsesmekanisme (18) kan gribe form- og/eller kraftssluttende ind i bundstykkeprofilens (11) optagenot (10), at adapterprofilen (16) på sin overside (19) har en optagenot (20), som er udformet kongruent til bundstykkeprofilens (11) optagenot (10), hvor adapterprofilens (16) optagenot (20) på oversiden optager føringsholderen (12) og sammen med oversiden (19) danner en flugtende, barrierefri kontakt, sådan at føringsholderen (12) valgfrit kan indføres i bundstykkeprofilens (11) optagenot (10) eller i adapterprofilens (16) optagenot (20), hvor der på adapterprofilens (16) respektive sider formes en synlig kontaktflade (21, 22), på hvilke der imod rummets inderside (23) kan placeres en indvendig bundflade (24) og imod rummets yderside (25) valgfrit forskellige udvidelsesprofiler (26, 27) til den udvendige bundflades (28) overgang, foretrukket til barrierefrie overgange.

2. Bundstykkessystem (9) eller afdækningsprofil ifølge krav 1, **kendetegnet ved, at** føringsholderen (12) er forsænket i adapterprofilens (16) optagenot (20) og ender flugtende med oversiden (19), hvor højden af optagenoten (20) svarer til højden på føringsholderen (12).

3. Bundstykkessystem (9) eller afdækningsprofil ifølge krav 1, **kendetegnet ved, at** adapterprofilen (16) tilpasser sig bundstykkeprofilen (11) og danner en modulær enhed.

4. Bundstykkessystem (9) ifølge krav 1, **kendetegnet ved, at** udformningen og afstandene i tværsnittet af adapterprofilen (16) i bredden (29) og højden (30) kan

vælges efter forskelligt udformede udvidelsesprofiler (26, 27), hvor adapterprofilen (16) kan adskilles variabelt i bredden (29) og dækkes af skydefløjen (3).

5 **5.** Bundstykkessystem (9) ifølge krav 1, **kendetegnet ved, at** forbindelsesmekanismen (18) i tværsnit strækker sig med kantet form i adapterprofilens (16) længde.

10 **6.** Bundstykkessystem (9) ifølge krav 1, **kendetegnet ved, at** forbindelsesmekanismen (18) er udformet til at gribe fast ind i bundstykkeprofilens (11) optagenot (10) til indgrebsforhindelse og/eller ved hjælp af yderligere fastgørelsesmidler.

15 **7.** Bundstykkessystem (9) ifølge krav 1, **kendetegnet ved, at** adapterprofilen (16) er udført i et massivt materiale eller en massiv profil eksempelvis af træ eller af et vilkårligt bærefast materiale, f.eks. marmor.

**8.** Bundtrinsystem (9) ifølge krav 1, **kendetegnet ved, at** adapterprofilen (16) er udført som hulkammerprofil af plast eller af aluminium som ekstruderet profil.

20 **9.** Bundstykkessystem (9) ifølge krav 1, **kendetegnet ved, at** adapterprofilen (16) på undersiden (17) mellem bundstykkeprofilen (11) på de respektive sider af forbindelsesmekanismen (18) mindst har en tætning (31, 32).

25 **10.** Bundstykkessystem (9) ifølge krav 1, **kendetegnet ved, at** adapterprofilen (16) med bundstykkeprofilen (11) bevirker en ændring i bundstykkessystemets (9) samlede højde (33) og strækker sig i en længde af de respektive indersider af de vertikale vanger eller i blændrammens (2) samlede længde.

30 **11.** Bundstykkessystem (9) ifølge krav 1, **kendetegnet ved, at** udvidelsesprofilen (26) på rummets yderside (25) er en afvandingsrist (34), som består af et påsætningslegeme (35) og af et rendelegeme (37) mellem påsætningslegemet (35) og bundstykkeprofilen (11), hvilket rendelegeme er dannet af afstandsblokke (36) placeret på bundstykkeprofilen (11) hældende i retning mod rummets yderside (25).

12. Bundstykkessystem (9) ifølge krav 1, **kendetegnet ved, at** udvidelsesprofilen (26) rækker i længden fra blændrammens (2) vertikale rammevange i låsesiden til den faste sektion af rammen (5), hvilket svarer til vinduets eller dørens (1) åbningsvidde, og i tværsnit i retning mod rummets inderside (23) ligger flugtende op ad adapterprofilen (16) og i retning mod rummets yderside (25) danner en flugtende kontakt med den ydre bundflade (28).

13. Bundstykkessystem (9) ifølge krav 1, **kendetegnet ved, at** adapterprofilen (16) har afvandingsudsparinger eller -boringer (38), som forløber hældende fra optagenoten (20) til rummets yderside (25) i retning mod udvidelsesprofilen (26).

14. Skydeelement med mindst en forskydelig fløj som skydefløj (3) eller forskydelig hæve-skydefløj på et vindue eller en dør (1), med et bundstykkessystem (9) ifølge et eller flere af de foregående krav.

15

15. Skydeelement, særligt en skyde- eller hæve-skydefløj (3) på et vindue eller en dør (1), hvor skydeelementet er forsynet med et bundstykkessystem (9) ifølge et eller flere af de foregående krav, med en optagenot (10) til en føringsholder (12) til kørerullerne (13) på en køreskinne (15) med ruller (14) på fløjsiden, hvilken optagenot er udført på oversiden af bundstykkeprofilen (11) over for skydefløj (3) til optag af føringsholderen (12), hvor føringsholderen (12) i hele sin længde kan indføres form-/ eller kraftsluttende i optagenoten (10), **kendetegnet ved, at** der er tilvejebragt mindst en adapterprofil (16), som med en på sin underside (17) konveks konfigureret forbindelsesmekanisme (18) kan gribe form- og/eller kraftsluttende ind i bundstykkeprofilens (11) optagenot (10), hvor adapterprofilen (16) på sin overside (19) har en optagenot (20), som er udformet kongruent med bundstykkeprofilens (11) optagenot (10), hvor adapterprofilens (16) optagenot (20) optager føringsholderen (12) på oversiden, sådan at føringsholderen (12) valgfrit kan indføres i bundstykkeprofilens (11) optagenot (10) eller i adapterprofilens (16) optagenot (20), hvor adapterprofilens (16) kontaktflader (21, 22) ved kontakt med de respektive sider danner en flugtende og jævn overgang til rummets inderside (23) og rummets yderside (25) ved hjælp af forskellige udvidelsesprofiler (26, 27).

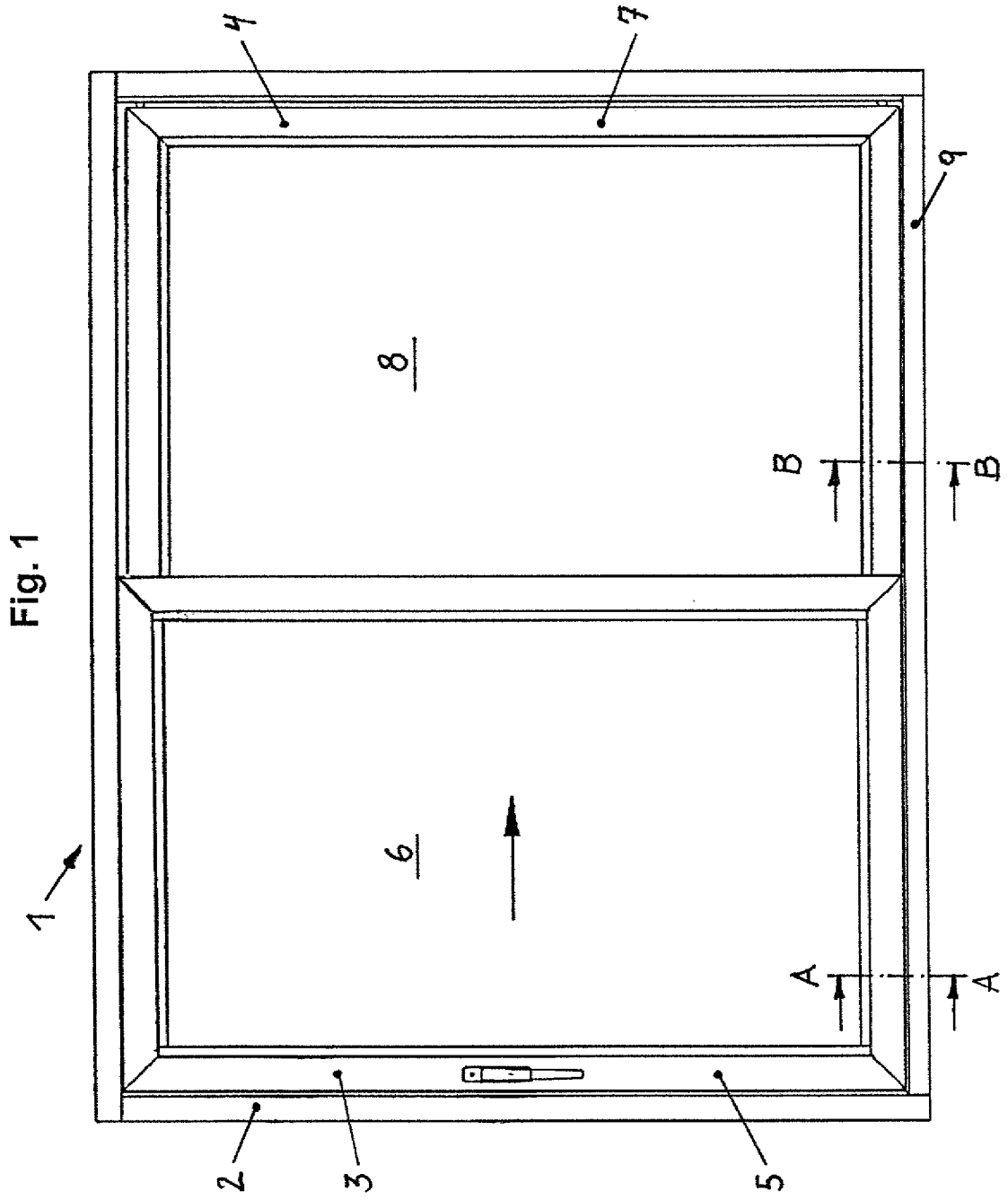

Fig. 3

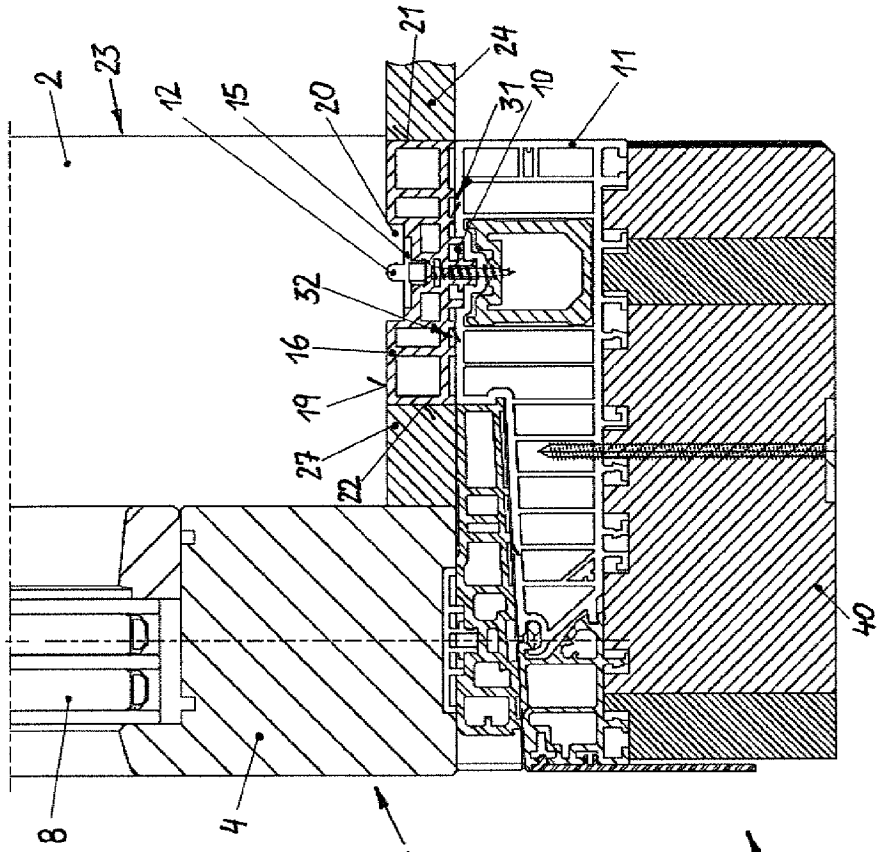

Fig. 2

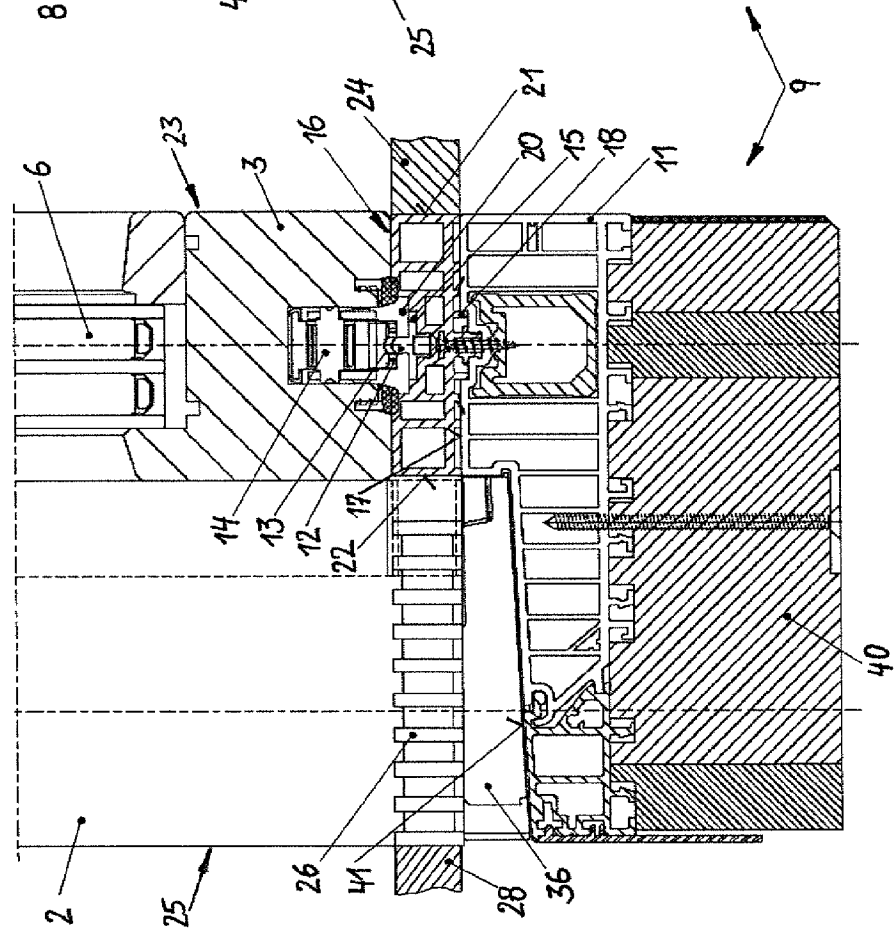

Fig. 5

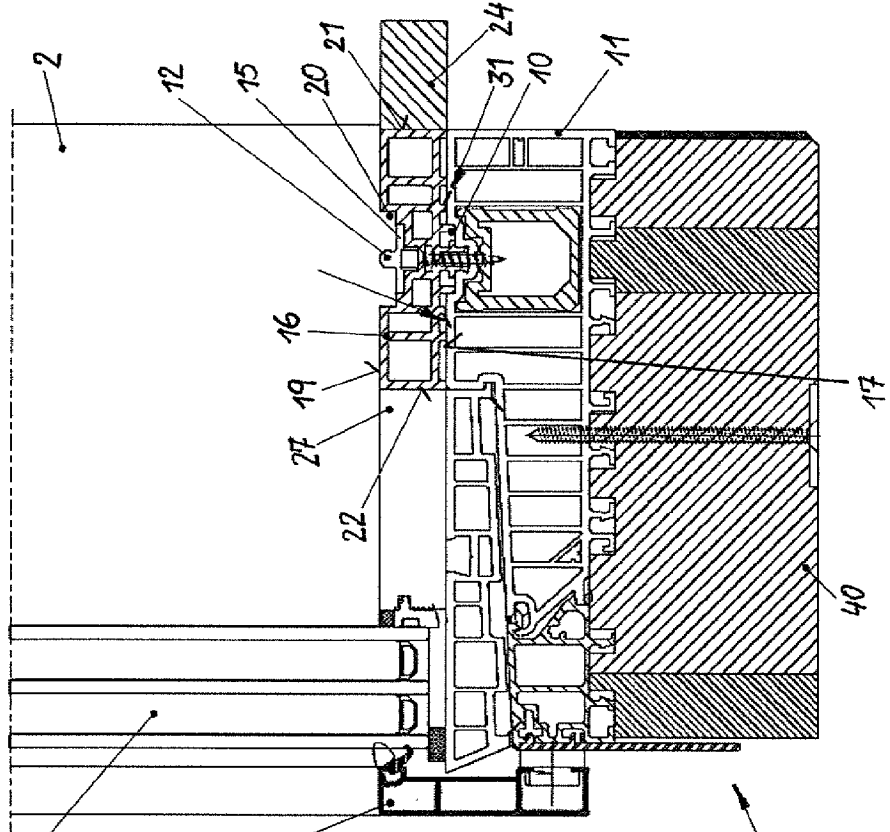

Fig. 4

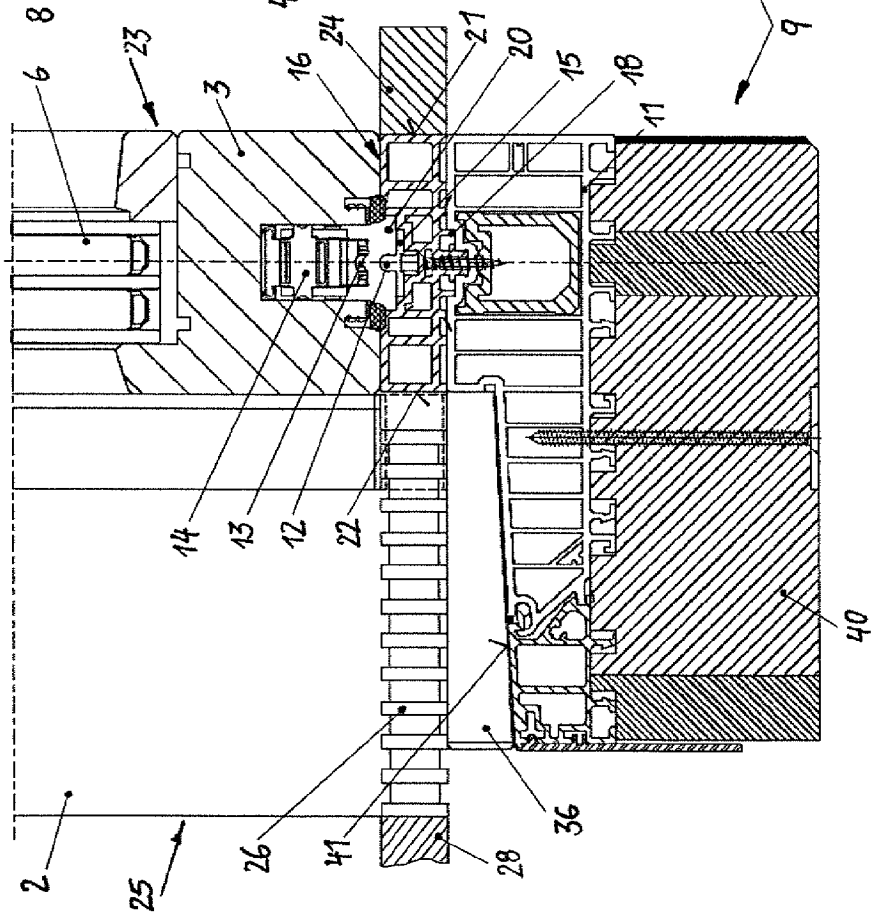

Fig. 6

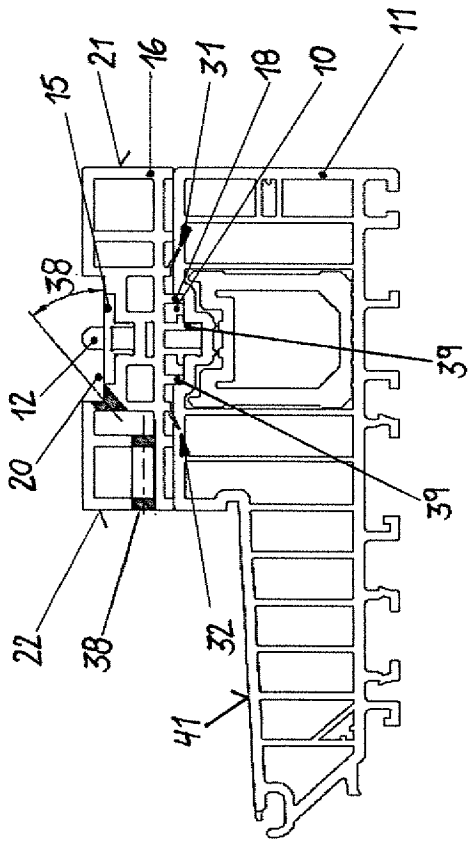

Fig. 7

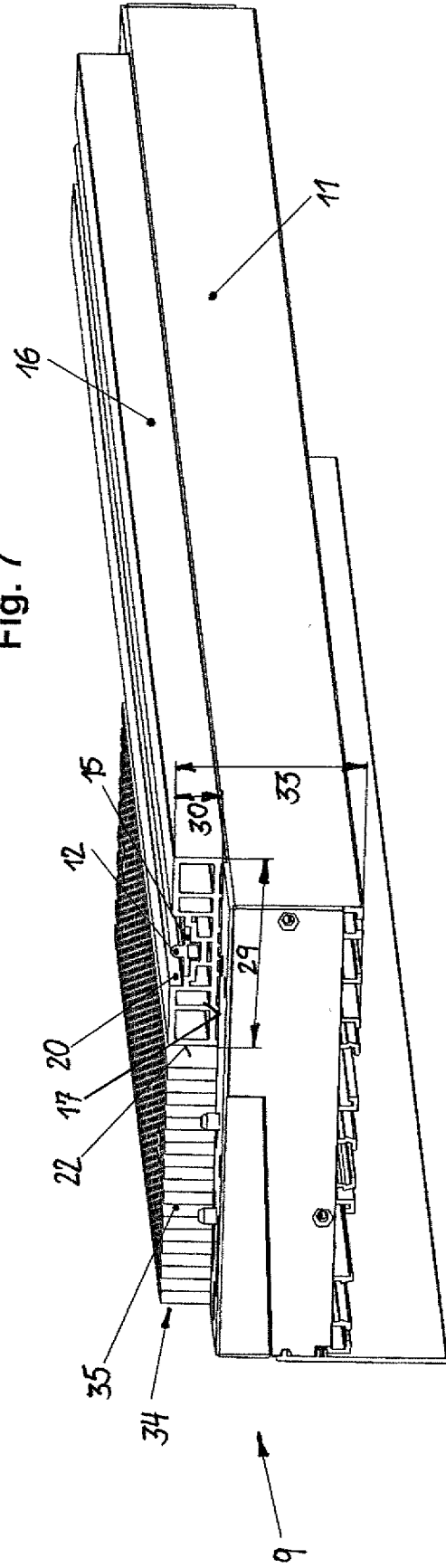

Fig. 9

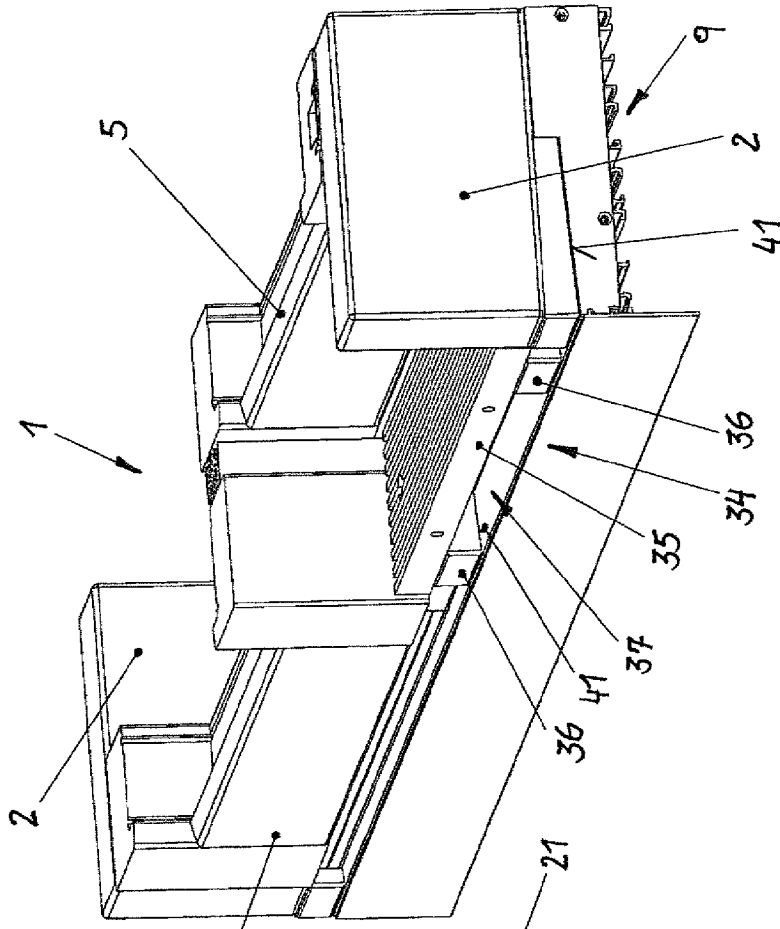

Fig. 8

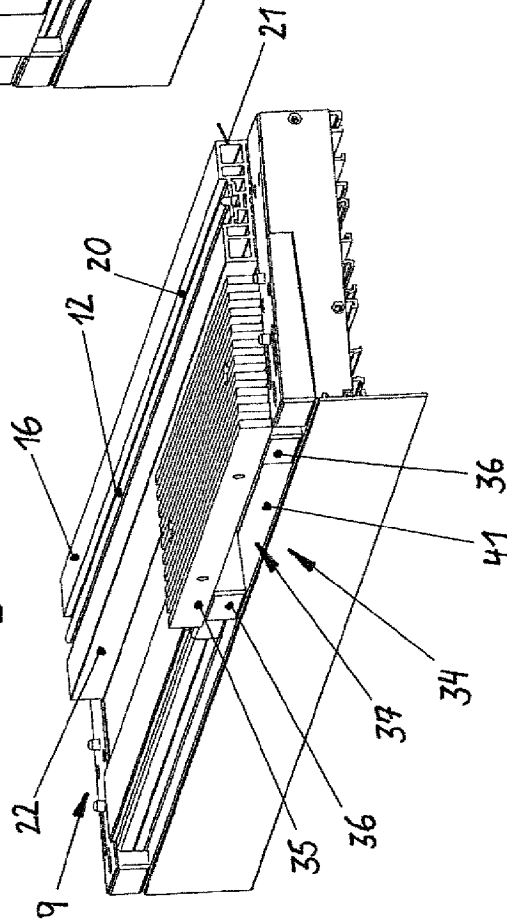

Fig. 10

