

July 22, 1947.

L. V. ANDREWS ET AL
STEAM PURIFYING APPARATUS

2,424,212

Filed July 29, 1944

2 Sheets-Sheet 1

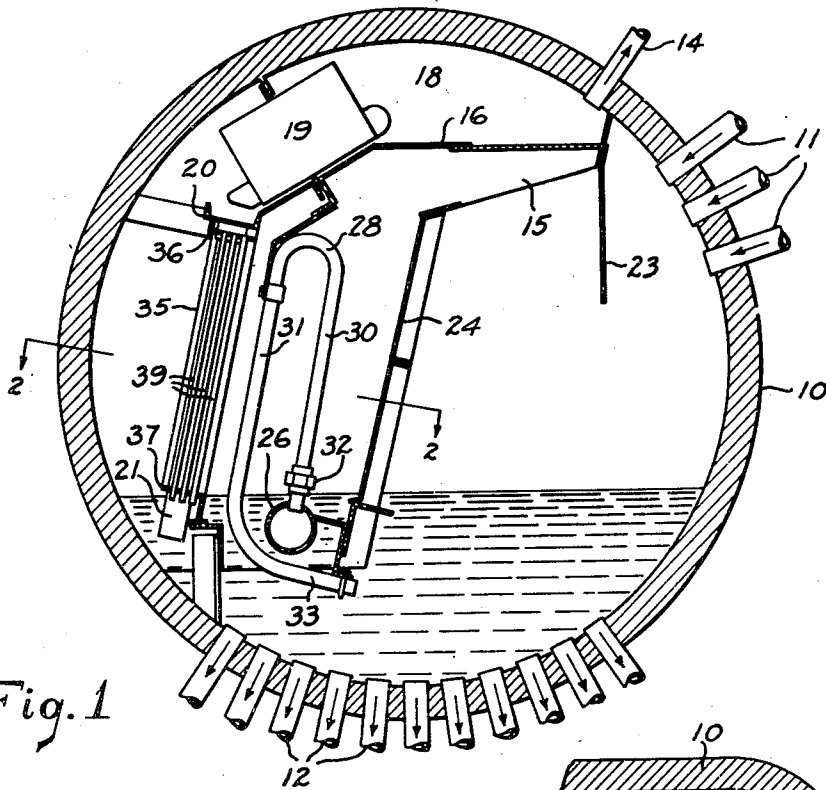

Fig. 1

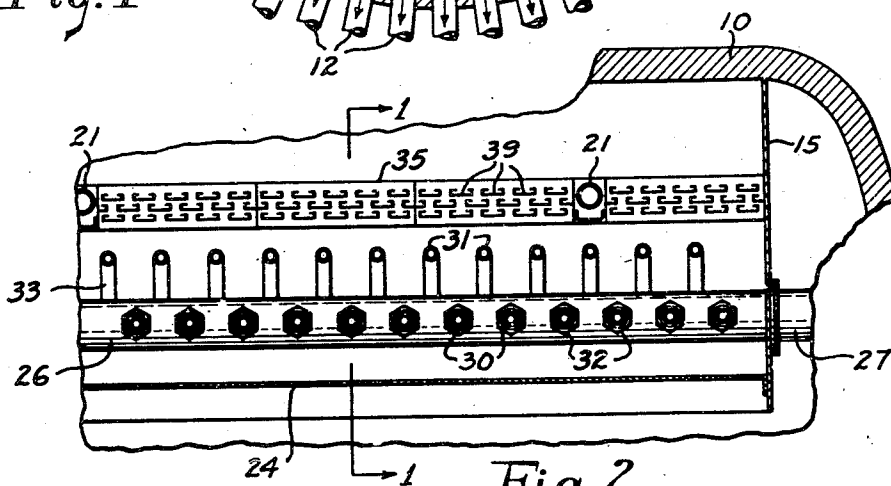

Fig. 2

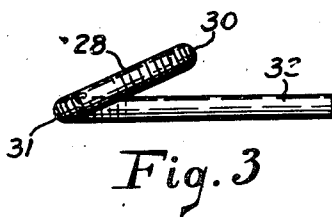

Fig. 3

Inventors
L. V. ANDREWS
GUSTAV A. REHM

By *Albert G. Blodgett*
Attorney

July 22, 1947.

L. V. ANDREWS ET AL
STEAM PURIFYING APPARATUS

2,424,212

Filed July 29, 1944

2 Sheets-Sheet 2

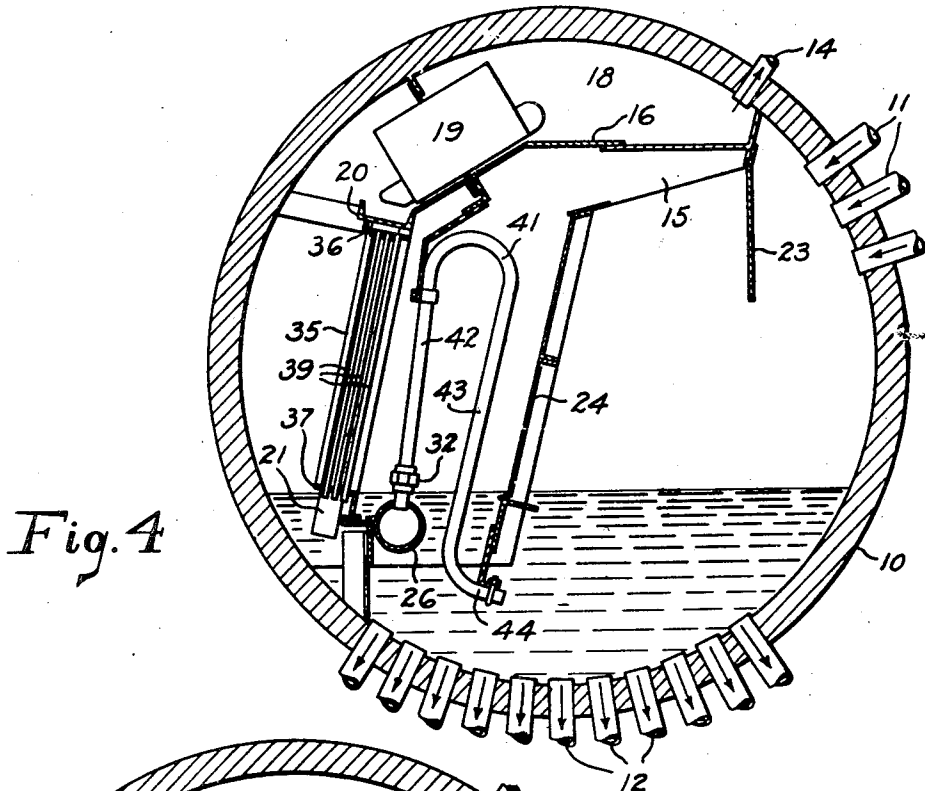

Fig. 4

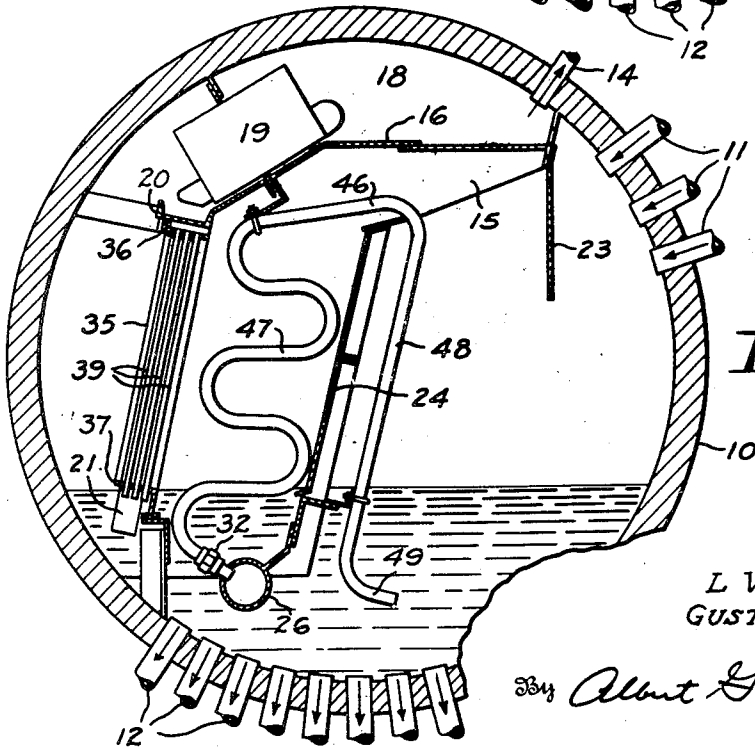

Fig. 5

Inventors
L V ANDREWS
GUSTAV A. REHM

By *Albert G. Blodgett*
Attorney

UNITED STATES PATENT OFFICE

2,424,212

STEAM PURIFYING APPARATUS

L. V. Andrews and Gustav A. Rehm, Worcester, Mass., assignors to Riley Stoker Corporation, Worcester, Mass., a corporation of Massachusetts

Application July 29, 1944, Serial No. 547,208

4 Claims. (Cl. 122-459)

1

This invention relates to steam purifying apparatus, and more particularly to apparatus capable of removing substantially all foreign matter from the steam before it leaves the boiler in which it is generated.

The prior patent to Andrews No. 2,287,592 shows a steam purifying apparatus mounted within the steam-and-water drum of a boiler, and in certain respects the present invention is an improvement over the construction disclosed in the said Andrews patent.

It is one object of the invention to provide a steam purifying apparatus which will operate efficiently despite appreciable variations in the boiler water level.

It is a further object of the invention to provide a steam purifying apparatus so constructed that there can be no possibility of contaminating the steam with foreign matter carried into the boiler with the feed water.

It is a further object of the invention to provide a steam purifying apparatus through which the boiler feed water is introduced into the boiler, the construction being such as to minimize the formation of sticky sludge within the boiler.

It is a further object of the invention to provide a steam purifying apparatus which can be readily removed for cleaning when required.

It is a further object of the invention to provide a steam purifying apparatus so constructed as to avoid water hammer during operation of the apparatus.

With these and other objects in view, as will be apparent to those skilled in the art, the invention resides in the combination of parts set forth in the specification and covered by the claims appended hereto.

Referring to the drawings illustrating one embodiment of the invention, and in which like reference numerals indicate like parts,

Fig. 1 is a section through a steam purifying apparatus, taken on the line 1-1 of Fig. 2;

Fig. 2 is a fragmentary section on the line 2-2 of Fig. 1;

Fig. 3 is a detail of one of the heat transfer elements of the apparatus;

Fig. 4 is a view similar to Fig. 1, showing a modification of the invention; and

Fig. 5 is a view similar to Fig. 4, showing a further modification of the invention.

The embodiment illustrated comprises a horizontal cylindrical boiler drum 10 which may form the steam-and-water drum of a well-known type of steam boiler. A bank of tubes 11 is connected to the front portion of the drum to deliver a mix-

2

ture of steam and water to the drum, and a bank of downcomer tubes 12 is connected to the lower portion of the drum. A row of steam outlet tubes 14 is connected to the upper front portion of the drum, above the tubes 11. As the steam and water mixture enters the drum from the tubes 11, the water for the most part will separate from the steam by gravity and escape downwardly through the tubes 12, while the steam will escape through the tubes 14. The present invention is concerned primarily with means to purify the steam before it reaches the outlet tubes 14.

Near each end of the drum there is provided a vertical plate 15 approximately semi-circular in shape and welded or otherwise secured to the surrounding cylindrical surface of the drum. These plates are located in the rear portion of the drum, with their free edges at the front. A partition wall 16 extends between the upper portions of the two plates 15 and is connected to the wall of the drum both in front of the tubes 14 and in the rear thereof, thus providing in the upper part of the drum a chamber 18 with which the steam outlet tubes 14 communicate. Before entering this chamber, the steam is forced to pass through a moisture separator 19 which extends through the rear portion of the partition 16. The separated moisture will be discharged downwardly and rearwardly into a channel member 20 extending longitudinally of the drum. From this channel member the moisture is conducted downwardly through pipes 21 to the pool of water in the bottom of the drum. This separator 19 may be of any desired type, one suitable construction being disclosed in the patent to Kuhner No. 2,235,892, granted March 25, 1941.

Before the steam reaches the separator 19, most of the boiler water carried in suspension by the steam is removed, and the steam is subjected to a washing action by pure water formed by condensing a portion of the steam. In this manner substantially all foreign matter, whether soluble or insoluble, is removed, and such moisture as does reach the separator is nearly pure water. An initial separation of the suspended boiler water from the steam is effected by an upright baffle 23 extending downwardly from the front portion of the wall 16 directly in the path of the steam and water mixture discharged rearwardly from the tubes 11, and arranged to deflect this mixture downwardly. Somewhat to the rear of the baffle 23 there is provided an upright plate or baffle 24 which preferably slopes forwardly and upwardly. The ends of this plate are connected to the plates 15, and its lower edge is submerged in the pool

3

of water within the drum. The upper edge of the plate 24 is spaced from the partition wall 16 thereabove to provide a passage for the rearward flow of the steam.

The steam is brought into heat transfer relationship with the boiler feed water in order that a portion of the steam may be condensed. For this purpose a horizontal pipe 26 extends longitudinally of the drum 10 in the rear of the plate 24 and preferably below the normal water level of the boiler, one end of this pipe being closed and its other end extending through the adjacent plate 16 and connecting with the feed water supply pipe 27 of the boiler. The pipe 26 discharges the feed water into a series of looped tubes 28 each shaped approximately as an inverted U with an up-flow leg 30 and a down-flow leg 31, these legs being offset laterally to provide two staggered rows of tubes in the path of the steam, as shown in Fig. 2. Each up-flow leg 30 is connected at its lower end to the pipe 26 by means of a detachable coupling or union 32. The down-flow legs 31 are positioned rearwardly of the up-flow legs, and the lower portions 33 of the legs 31 are located in the lower portion of the drum and bent forwardly to discharge the feed water forwardly beneath the lower edge of the plate 24. Thus any chemicals which may be dissolved in the feed water will have an opportunity to react with the chemicals in the boiler water in a region where highly alkaline conditions prevail, rather than being carried directly into the rearmost of the down-comer tubes 12. This results in the formation of sludges which will remain in free circulation rather than sticky sludges which would adhere to the boiler surfaces and obstruct the water circulation and the transfer of heat.

Since the temperature of the feed water flowing through the tubes 28 is below that of the steam, some of the steam will be condensed on the outer surfaces of the tubes. This condensate will collect soluble and insoluble impurities from the steam, and much of this material will flow downwardly by gravity along the tubes into the pool of boiler water, thereby effecting a primary washing of the steam. Some of the impurities in the steam will travel between the tubes 28 without coming into contact therewith, and in order to remove such impurities a scrubber 35 is mounted directly behind the tubes 28. This scrubber is constructed of a plurality of separate sections mounted between the drain pipes 21. Each scrubber section comprises upper and lower plates 36 and 37 respectively connected by upright bars 38, these bars being arranged in a plurality of rows which extend longitudinally of the drum, with the bars in adjacent rows staggered. The bars 38 are preferably in the form of rectangular tubes with an open slot in the rear wall of each tube, so that the cross section of each bar is that of a rearwardly open channel. The lower ends of the bars 38 extend through the lower plate 37 so that moisture collected in the interior of the channels will be discharged by gravity into the boiler water.

In the operation of the invention a mixture of steam and water is discharged into the drum 10 from the tubes 11 and impinges on the baffle 23, which deflects the mixture downwardly and causes most of the water to be deposited in the pool of boiler water. From this pool water travels downwardly through the tubes 12, so that there will be a continuous flow of water through the drum in a downward and rearward direc-

4

tion. The steam flows beneath the baffle 23, then rearwardly over the top of the plate 24 and into contact with the tubes 28, some boiler water being carried in suspension with the steam. The boiler feed water flows from the feed pipe 27 into the pipe 26 and thence through the tubes 28, from which it is discharged in a forward direction by the tube portions 33. The feed water is thus projected into the boiler water in a direction opposite to the flow of water through the drum, and any chemicals carried by the feed water will have an opportunity to react with the boiler water in the region of maximum alkalinity. The sludge which forms under these conditions is of a non-sticky nature and will remain in free circulation until it is removed by the operation of the boiler blow-down system. As the steam comes into contact with the relatively cool tubes 28, any foam which is present in the steam will be chilled and the foam bubbles will collapse, greatly reducing the opportunity for entrainment of foreign matter by the steam. The tubes 28 will also remove some of the heat from the steam and cause condensate to form on the outer surfaces of the tubes. Some of the condensate will flow downwardly along the tubes, carrying along foreign matter which is deposited on the tubes by the steam. The remaining condensate will be swept from the tubes by the steam and carried into the scrubber 35 to keep the bars 38 wetted with relatively pure water, so that a further washing action will take place there. The velocity of the steam past the bars will create a region of reduced pressure within the interior of the bars, and this will cause moisture to leave the steam and enter the bars, thereupon flowing downwardly through the bars by gravity. Such moisture as remains in the steam when it leaves the scrubber 35 will be comparatively free from impurities, and most of this moisture will be removed by the separator 19 before the steam reaches the outlet tubes 14. During the passage of the steam through the relatively cool zone adjacent the tube loops 28, the droplets of boiler water carried in suspension will be enlarged by the formation of condensate thereon, and these larger droplets are much more readily separated from the steam.

Even though the water level in the boiler drum 10 may rise considerably above the level illustrated, there will still be ample space available for the steam flow without danger of excessive carry-over and possible flooding of the separator. Since the feed water is fully enclosed by the tubes 28 there is no opportunity for the steam to be contaminated by impurities in the feed water. The discharge ends of the tubes 28 being submerged in the boiler water, no steam can enter these tubes even if the feed water flow should cease temporarily. Consequently the danger of water hammer caused by steam condensing within these tubes or within the pipe 26 is eliminated. If the tubes 28 should ever require cleaning they can easily be removed by disconnecting the unions 32.

In Fig. 4 there is shown a slight modification in which the tube loops 28 of Fig. 1 are replaced by tube loops 41 each having an up-flow leg 42 and a down-flow leg 43, the latter terminating in a forwardly bent portion 44 extending beneath the plate 24. In this embodiment the up-flow legs are located behind the down-flow legs rather than in front thereof, but it is not believed that this change will bring about any appreciable difference in operation.

5

In Fig. 5 there is shown a further modification in which the tube loops 28 of Fig. 1 are replaced by tube loops 46 each having an up-flow leg 47 and a down-flow leg 48, the latter terminating in a forwardly bent portion 49. In this embodiment the down-flow legs 48 are located in front of the plate 24, where they will be particularly effective in chilling and collapsing any mass of foam which may accumulate against the front surface of this plate. The up-flow legs 47 are made in sinuous form in order to present a larger surface area for contact with the steam and thereby increase the amount of condensate formed. In all essential particulars the operation will be similar to that of the other embodiments described.

Having thus described our invention, what we claim as new and desire to secure by Letters Patent is:

1. Steam purifying apparatus comprising a horizontal boiler steam-and-water drum having a steam outlet in its upper portion and a pool of boiler water in its lower portion, means to deliver a mixture of steam and water to the drum, downcomer tubes connected to the lower portion of the drum, a series of looped tubes arranged in a longitudinal row within the drum and extending across the path of the steam as it flows toward the outlet, each looped tube having an up-flow leg and a down-flow leg connected at their upper ends, the down-flow legs extending into the pool of boiler water, and means to supply boiler feed water to the lower ends of the up-flow legs.

2. Steam purifying apparatus comprising a horizontal boiler steam-and-water drum having a steam outlet in its upper portion and a pool of boiler water in its lower portion, means to deliver a mixture of steam and water to the drum, downcomer tubes connected to the lower portion of the drum, a series of looped tubes arranged in a longitudinal row within the drum and extending across the path of the steam as it flows toward the outlet, each looped tube having an up-flow leg and a down-flow leg connected at their upper ends, the down-flow legs extending into the pool of boiler water, and a boiler feed water supply pipe extending longitudinally of the drum and connected to the lower ends of the up-flow legs.

3. Steam purifying apparatus comprising a

6

horizontal boiler steam-and-water drum having a steam outlet in its upper portion and a pool of boiler water in its lower portion, means to deliver a mixture of steam and water to the drum, downcomer tubes connected to the lower portion of the drum, a series of looped tubes arranged in a longitudinal row within the drum and extending across the path of the steam as it flows toward the outlet, each looped tube having an up-flow leg and a down-flow leg connected at their upper ends, the up-flow legs being staggered relative to the down-flow legs and the down-flow legs extending into the pool of boiler water, and means to supply boiler feed water to the lower ends of the up-flow legs.

4. Steam purifying apparatus comprising a horizontal boiler steam-and-water drum having a steam outlet in its upper portion and a pool of boiler water in its lower portion, tubes to deliver a mixture of steam and water to the front portion of the drum, downcomer tubes connected to the lower portion of the drum, a series of looped tubes arranged in a longitudinal row within the drum and extending across the path of the steam as it flows toward the outlet, each looped tube having an up-flow leg and a down-flow leg connected at their upper ends, and means to supply boiler feed water to the lower ends of the up-flow legs, the lower ends of the down-flow legs being immersed in the said pool and bent forwardly to discharge the feed water in a forward direction below the surface of the boiler water.

L. V. ANDREWS,
GUSTAV A. REHM.

REFERENCES CITED

The following references are of record in the file of this patent:

UNITED STATES PATENTS

Number	Name	Date
2,058,239	Kerr	Oct. 20, 1936
2,075,059	Rosencrants et al.	Mar. 30, 1937
2,256,115	Hobbs	Sept. 16, 1941
2,287,592	Andrews	June 23, 1942
1,948,524	Kerr	Feb. 27, 1934
536,096	Quiggin	Mar. 19, 1895
2,055,781	Angermueller	Sept. 29, 1936
2,067,080	Frankel	Jan. 5, 1937