

June 2, 1942.

N. J. CONRAD

2,285,252

CIRCUIT INTERRUPTING APPARATUS

Original Filed Sept. 8, 1938

Fig. 1.

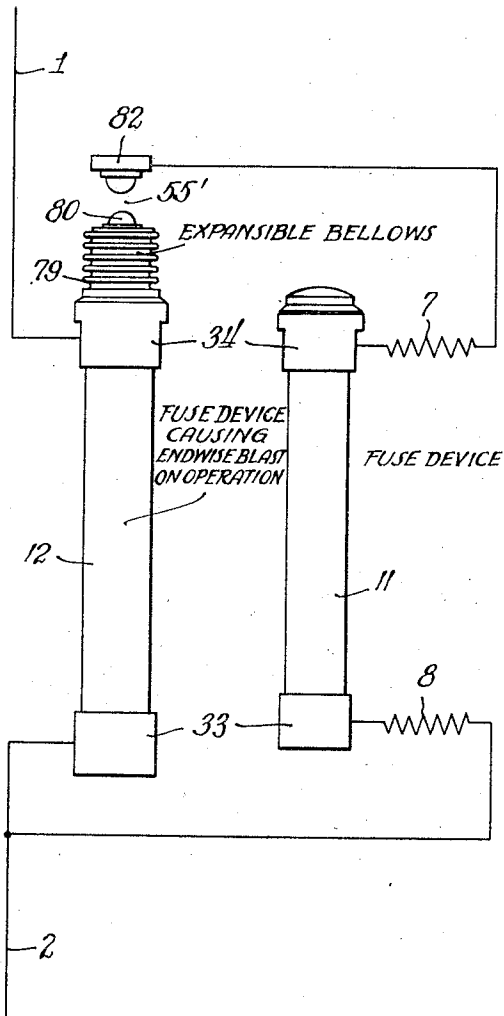
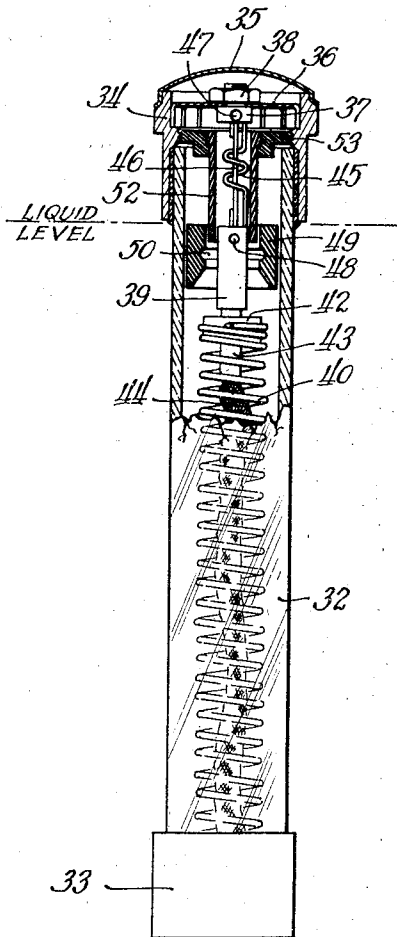

Fig. 2.



Inventor:
Nicholas J. Conrad.

By

Max Jackson Böttcher, Designer

Attys.

UNITED STATES PATENT OFFICE

2,285,252

CIRCUIT INTERRUPTING APPARATUS

Nicholas J. Conrad, Winnetka, Ill., assignor to Schweitzer & Conrad, Inc., Chicago, Ill., a corporation of Delaware

Application September 8, 1938, Serial No. 228,980, which is a division of application Serial No. 637,593, October 13, 1932, now Patent No. 2,134,470, dated October 25, 1938. Divided and this application April 29, 1940, Serial No. 332,247

11 Claims. (Cl. 200—120)

My invention relates, generally, to circuit interrupting apparatus and it has particular relation to the construction thereof.

This application is a division of my copending application, Serial No. 228,980, filed September 8, 1938, now Patent No. 2,223,601, which is a division of my application, Serial No. 637,593, filed October 13, 1932, now Patent No. 2,134,470, issued October 25, 1938.

An object of this invention is to provide for operation of a flexible member from one position to another on operation of a circuit interrupter.

Another object of this invention is to close one end of a blast type circuit interrupter by a flexible member a part of which is moved from one position to another on operation of the circuit interrupter.

A further object of this invention is to hermetically seal one end of a liquid fuse device by means which expands on operation of the fuse device.

For a more complete understanding of my invention, reference may be had to the following detailed description taken in connection with the accompanying drawing, in which:

Figure 1 illustrates diagrammatically an embodiment of the invention; and

Figure 2 is a side elevational view, partly in section, of one form of fuse which may be employed in the practice of my invention.

Referring first to Figure 1, the circuit interrupter is indicated between the conductors 1 and 2. Two liquid quenched fuses 11 and 12 are employed, the fuse 11 being connected through resistors 7 and 8 in parallel with the fuse 12. The proportions of the fuses may, for example, be as follows:

Fuse 11, ½ ampere rating; fuse 12, 25 ampere rating, with the resistance of the resistors 7 and 8 consisting of 55.5 ohms.

Another example of proportioning for a different circuit, is as follows:

Fuse 11, 5 amperes rating; fuse 12, 100 amperes rating; with a resistance, in series, of 55.5 ohms.

The fuses 11 and 12 are preferably well known fuses now on the market. A suitable construction of fuse is shown in Figure 2. Various modifications of the fuse of Figure 2 are disclosed in my Patent No. 2,091,430, issued August 31, 1937. A suitable fuse for this purpose is also disclosed in my prior Patents No. 1,743,322 of January 14, 1930, and No. 1,834,578 of December 1, 1931. A sufficient description of such fuses and their operation is contained in said prior patents, and a brief description of the fuse shown in Figure 2 will suffice for present purposes.

The fuse comprises a glass sleeve 32 having metallic terminals at the ends thereof, the lower terminal 33 being in the form of a closed cap cemented on the glass sleeve, and the upper terminal 34 being in the form of a ferrule or sleeve likewise cemented on the upper end of the glass sleeve 32. The upper ferrule 34 is closed releasably by a cap 35 which, in case of excessive pressure and upon heavy blowing of the fuse, is adapted to be removed by the internal pressure. The sleeve or ferrule 34 is counterbored to provide a shoulder for mounting the upper terminal plate 36, which has slotted spring fingers pressing radially against the walls of the counterbore and axially against the shoulder formed by the counterbore. A terminal stud 37 has a threaded shank extending through the plate 36 and it is held in place by the nut 38 threaded on said shank. A cooperating movable terminal 39 is mounted upon the upper end of the tension spring 40 through the medium of a spring head 42, to which the spring 40 is anchored. This spring head 42 has a threaded coupling with the terminal 39 and also has a socket 43 to which the flexible cable 44 is firmly anchored, electrically and mechanically. The cable 44 shunts the spring 40. A silver fuse wire 45 formed in the shape of a helix with the ends straightened out axially is connected between the movable terminal 39 and the stationary terminal 37. A high tensile strength wire, preferably of nickel-chromium-alloy composition, indicated at 46, has loops formed at each end and these loops are engaged by pins 47 and 48 in the terminals 37 and 39, respectively. The ends of the fusible link 45 are mechanically anchored in slots in the terminals 37 and 39 to give a good mechanical and electrical anchorage, the edges of the slots being riveted or battered over to grip the fuse wire along a considerable length. A liquid director 49 is supported on radially extending arms 50 upon the terminal 39. An explosion chamber is provided about the fusible element by means of the sleeve 52, the upper end of which is pressed into or otherwise anchored in the barrier plate 53, which barrier plate is threaded into the bore of the ferrule 34 to form a transverse wall. The upper end of the liquid director 49 embraces loosely but fairly closely the upper end of the explosion chamber sleeve 52. The glass sleeve is filled with arc extinguishing liquid to a point preferably just above the liquid director 49.

In operation, upon the occurrence of overload the fuse element 45 first melts, throwing the load over upon the high tensile strength wire 46,

termed the strain wire. Thereupon the strain wire melts and looses the coil spring 40 to retract the terminal 39. At the same time arc extinguishing liquid is thrown into the explosion chamber 52, this stream of liquid being rapidly vaporized and to some extent broken down, and discharged upwardly into the chamber formed above the barrier plate 53. Here the vapors and gases are condensed and chilled, and if the arc is interrupted before the pressure rises to too high a value the operation of interrupting current flow occurs without blowing of the cap 35. If the operation is severe, as in a short circuit on a system of large capacity, the pressure in the fuse may rise to a value high enough to blow off the cap 35. The terminal plate 36 and terminal 37 may then also be expelled, and as the terminal 39 and liquid director 49 descend, vapors and gases of high pressure and very high velocity are expelled through the explosion chamber, tending to deionize or deactivate the gases carrying the arc, to put out the same.

Referring now to Figure 1, it will be observed that the cap 35 is omitted from the fuse 12 and that instead it is provided with an expandible member or bellows 79, which carries a contact 80 adapted to cooperate with the contact 82, forming the terminals of the gap 55'. In this case the pressure developed in the fuse 12 switches in the shunt circuit by either bringing the contacts 80 and 82 into engagement or bringing them near enough to each other that the voltage drop across the gap will break the gap down and switch in the shunt circuit.

In operation the fuse 12 normally carries the entire current flowing through the circuit represented by the conductors 1 and 2. On the occurrence of an overload in this circuit, the fuse 12 operates as previously described. The pressure generated as a result of the blast action of the arc extinguishing material causes the expandible member or bellows 79 to be extended for closing the gap 55'. In such case the contact 80 may be moved into contact engagement with the contact 82. In either case the auxiliary circuit is then connected for energization to the current source represented by the conductors 1 and 2. The current flow is then transferred to the fuse 11 but it is materially limited by the resistors 7 and 8. The fuse 11 then operates in the manner previously described to open the path through the auxiliary circuit in which it is connected. Since the path between the conductors 1 and 2 has now been opened by the fuse 12 in the main circuit and the fuse 11 in the auxiliary circuit, no further flow of current takes place.

I do not intend to be limited to the specific details which I have above described. I do not wish to limit the arc extinguishing material, nor the specific form of the fuses, to the forms above described for the reason that those skilled in the art will at once appreciate that the mode of operation which I have explained may be embodied in forms structurally quite different but mechanically the equivalent of the aforesaid.

I claim:

1. Circuit control apparatus comprising, in combination, a liquid fuse device adapted to be mounted in an upright position for connection in a circuit to automatically interrupt the same on the occurrence of a predetermined overload, and a flexible bellows hermetically sealed to one end of said fuse device and forming therewith a unitary device, said flexible bellows itself serving

to close said one end of said fuse device and to expand as a result of blowing thereof.

2. Circuit control apparatus comprising, in combination, a liquid fuse device adapted to be mounted in an upright position for connection in a circuit to automatically interrupt the same on the occurrence of a predetermined overload, and a flexible bellows hermetically sealed to the upper end of said fuse device and being free of the liquid therein and forming therewith a unitary device, said flexible bellows itself serving to close said upper end of said fuse device and expanding on blowing thereof.

3. Circuit control apparatus comprising, in combination, a fuse device of the blast action arc extinguishing type for connection in a circuit to automatically interrupt the same on the occurrence of a predetermined overload, and a flexible bellows closing one end of said fuse device and located directly in the path of the blast generated on blowing of said fuse device and adapted to expand as a result of the pressure of said blast.

4. A circuit interrupter comprising, in combination, an insulating housing having terminals at its ends for connection to an electric circuit, means within said housing adapted to form an arc on operation of the circuit interrupter as a result of an overload in said circuit, and a flexible member secured to one of said terminals and having a central portion adapted to be moved to an alternate position on operation of the circuit interrupter while the portion secured to said one terminal remains stationary.

5. A circuit interrupter comprising, in combination, an insulating housing having terminals at its ends for connection to an electric circuit, means within said housing adapted to form an arc on operation of the circuit interrupter as a result of an overload in said circuit, one of said terminals comprising a metallic ferrule, and a flexible member hermetically sealed to the outer end of said ferrule with the central part thereof adapted to move outwardly endwise of said housing on operation of the circuit interrupter while the rim thereof remains attached to said ferrule.

6. A circuit interrupter comprising, in combination, an insulating housing having terminals at its ends for connection to an electric circuit, means within said housing adapted to form an arc on operation of the circuit interrupter as a result of an overload in said circuit, means responsive to the heat of the arc for generating pressure acting outwardly of one end of said housing, and flexible means secured to the terminal at said one end of said housing and adapted to have a central portion thereof moved outwardly of said housing by said pressure while the whole remains attached to said terminal at its outer portion.

7. A circuit interrupter comprising, in combination, a tubular insulating housing having ring-like metal terminals at its ends for connection to an electric circuit, one of said terminals including means forming a rigidly closed cap, fusible means within said housing adapted to form an arc on operation of the circuit interrupter as a result of an overload in said circuit, and a flexible member hermetically sealed to the outer end of the other ring-like terminal with the central part thereof adapted to move outwardly endwise of said housing on operation of the circuit interrupter while the rim thereof remains attached to said other terminal.

8. A circuit interrupter comprising, in combination, a tubular insulating housing having ring-

like metal terminals at its ends for connection to an electric circuit, one of said terminals including means forming a rigidly closed cap, fusible means within said housing adapted to form an arc on operation of the circuit interrupter as a result of an overload in said circuit, means responsive to the heat of the arc for generating pressure acting outwardly through the other of said terminals, and deformable means secured to the outer end of said other terminal with the central part thereof adapted to be moved outwardly by said pressure while the rim thereof remains attached to said other terminal.

9. A circuit interrupter comprising, in combination, a tubular insulating housing having ring-like metal terminals at its ends for connection to an electric circuit, one of said terminals including means forming a rigidly closed cap, fusible means within said housing adapted to form an arc on operation of the circuit interrupter as a result of an overload in said circuit, and a flexible bellows closed at one end and open at the other with the open end hermetically sealed to the outer end of the other ring-like terminal, said closed end of said flexible bellows moving outwardly endwise of said housing on operation of the circuit interrupter.

10. A circuit interrupter comprising, in combination, an insulating housing having terminals at its ends for connection to an electric circuit at least one of which terminals comprises a metallic ferrule, means within said housing for interrupting said electric circuit as a result of an overload therein, and a flexible member having a central portion adapted to be moved to an alternate position outwardly of said housing on interruption of said circuit and an outer portion attached to said metallic ferrule.

11. A circuit interrupter comprising, in combination, an insulating housing having terminals at its ends for connection to an electric circuit at least one of which terminals comprises a metallic ferrule, means within said housing for interrupting said electric circuit as a result of an overload therein accompanied by an endwise blast through said metallic ferrule, and a flexible member secured to said metallic ferrule and having a portion adapted to be moved outwardly thereof as a result of said blast whereby the volume of the space enclosed by said housing and flexible member is increased.

NICHOLAS J. CONRAD.