

(No Model.)

E. G. COHEN.
MACHINE FOR ATTACHING TAGS.

No. 452,097.

Patented May 12, 1891.

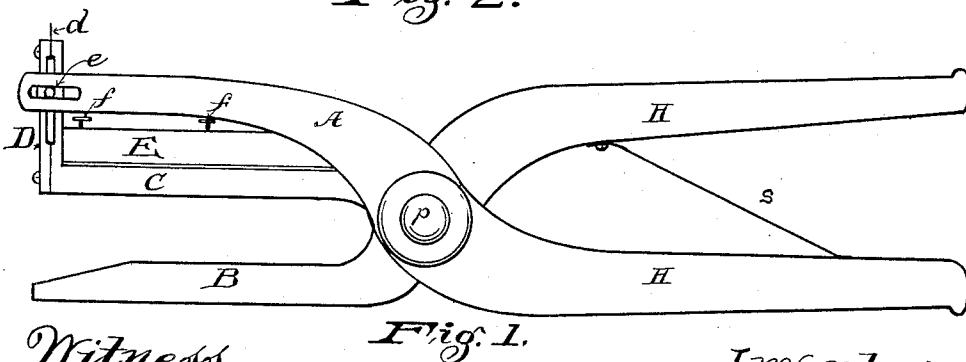
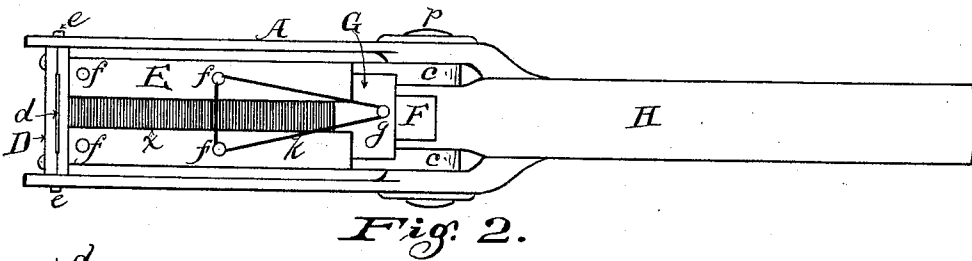
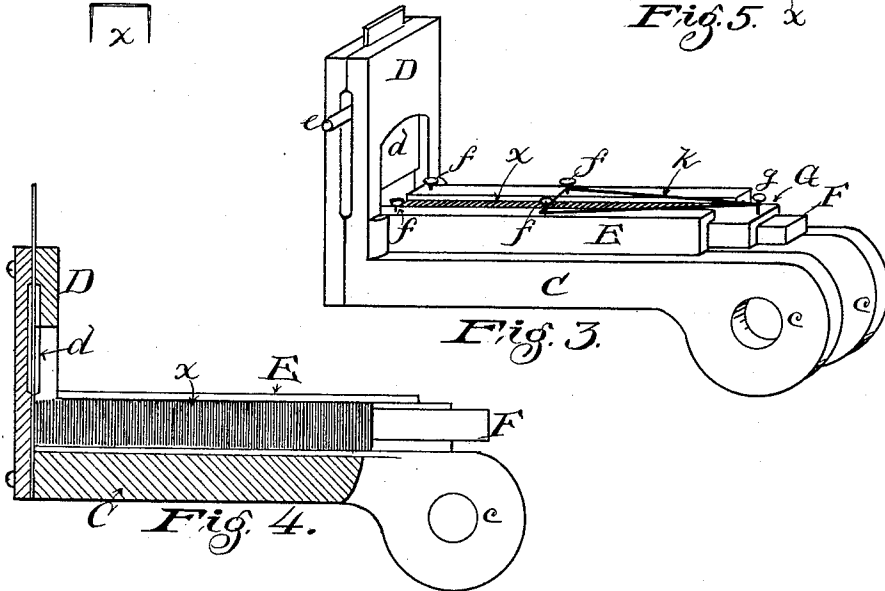
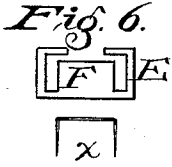

Witness,

E. Jay Purney
A. E. Norton.

Inventor,

E. George Cohen.
By Geo. M. Tibbitts
attor.

UNITED STATES PATENT OFFICE.

EMANUEL GEORGE COHEN, OF CLEVELAND, OHIO.

MACHINE FOR ATTACHING TAGS.

SPECIFICATION forming part of Letters Patent No. 452,097, dated May 12, 1891.

Application filed December 10, 1890. Serial No. 374,256. (No model.)

To all whom it may concern:

Be it known that I, EMANUEL GEORGE COHEN, a citizen of the United States, residing at Cleveland, in the county of Cuyahoga and State of Ohio, have invented certain new and useful Improvements in Machines for Attaching Tags to Garments and like Articles, of which the following is a specification.

This invention relates to a hand implement for attaching tags or labels to garments and other like goods by means of wire staples, and has for its object to greatly facilitate such work and to reduce the time and expense of performing the same.

The invention consists in the novel constructions and combinations comprising this implement, as hereinafter fully described, and pointed out in the claim.

In the accompanying drawings, Figure 1 is a side elevation, and Fig. 2 is a top or plan view, of my new implement ready for use. Fig. 3 is a detached view of the staple holding, feeding, and setting part of the implement. Fig. 4 is a longitudinal section of the same. Fig. 5 is a sectional view of the staple-holder. Fig. 6 is an end view of same.

A and B represent the two main jaws of the device, each being provided with handles H H, in form like a pair of pinchers, to be grasped and manipulated by the hand of the operator. A retracting-spring *s* is fixed between said handles to spread them apart. The upper jaw A is made in the form of a fork, as seen in Fig. 2, and between this fork is pivoted the jaw B.

C is a plate having its inner end bifurcated, forming eyes *c c*, by which it is also attached to the pivotal pin *p* between the aforesaid fork, the said eyes straddling the journal of the jaw B, as seen in Fig. 2. The forward end of said plate C has a head D permanently fixed thereto. Within the head D is provided a sliding plunger *d* in a narrow vertical slot in said head, having lugs or pins *e e* extending through slots in the sides of the head, the said pins also engaging with slots in the ends of the fork A, as seen in Figs. 1 and 2, by means of which the plunger is moved.

E is a staple-holder consisting of a rectangular box having a longitudinal opening throughout the middle of its top and having a longitudinal bar F secured to the bottom and extending beyond the rear end. Upon this bar the staples *x* are placed, lying astride, as seen in Fig. 5. G is a follower-block, which also sits astride of said bar F, and is designed for a pusher to feed forward the staples.

K is an india-rubber or elastic band stretched and held by a pin or hook *g* on the block G and by pins or hooks *ff* on the box E, provided for forcing said follower-block inward for feeding the staples to the plunger as fast as they are used.

The manner of using this implement is as follows: The operator takes it in hand in like manner to a pair of pliers or pinchers. With the other hand a tag or label is laid on the garment, and then the implement is placed with the head of the staple-holder upon the said tag. Then by compressing the handles the jaws are brought together and a staple is forced through the tag and the fabric of the garment, the opposite jaw bending and clinching the staple down on the under side of the fabric, thus accomplishing the securing of tags firmly and in much quicker time than could possibly be done by sewing or otherwise.

Having described my invention, I claim—

The herein-described hand implement for attaching tags by means of staples, consisting of bifurcated jaw A, jaw B, and plate C, joined by pivotal pin *p*, plate C having slotted head D, provided with plunger *d*, operated by jaw A, plate C also having staple-holder E F and follower G, follower G impelled by the elastic band K for feeding the staples forward, constructed and operating substantially as and for the purpose specified.

E. GEORGE COHEN.

Witnesses:

GEO. W. TIBBITTS,
CHARLES ZUCKER.