

C. C. WILSON.
MACHINE FOR WRAPPING KISSES, &c.

No. 110,812.

Patented Jan. 3, 1871.

Fig 1

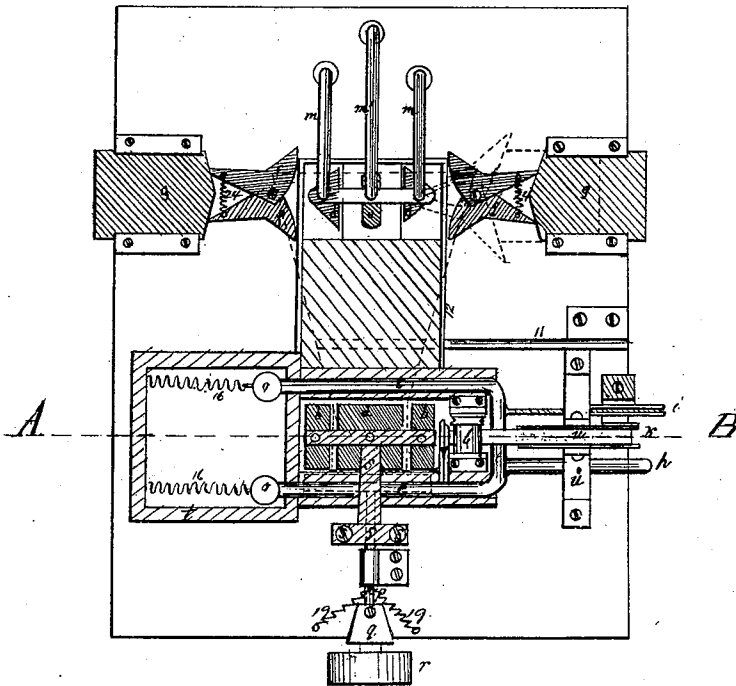
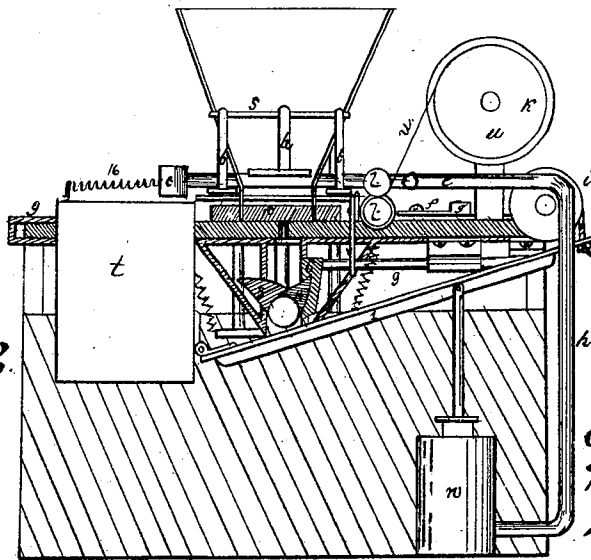

Fig. 2.



Section from the line AB.

Witnesses.
 G. L. Ewert.
 A. H. Mann

Inventor.
 Chas. C. Wilson
 per
 H. C. Mason
 attys.

C. C. WILSON.
MACHINE FOR WRAPPING KISSES, &c.

No. 110,812.

Patented Jan. 3, 1871.

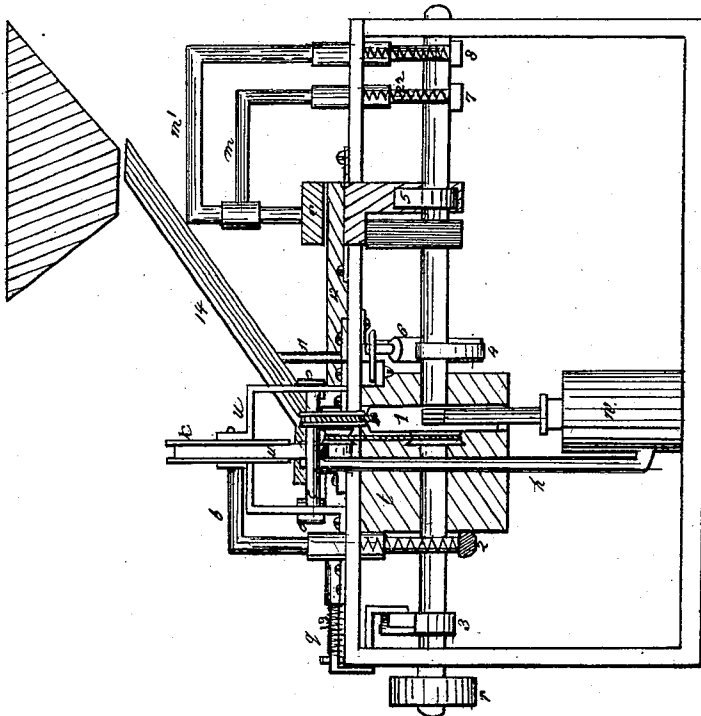

Fig. 3.

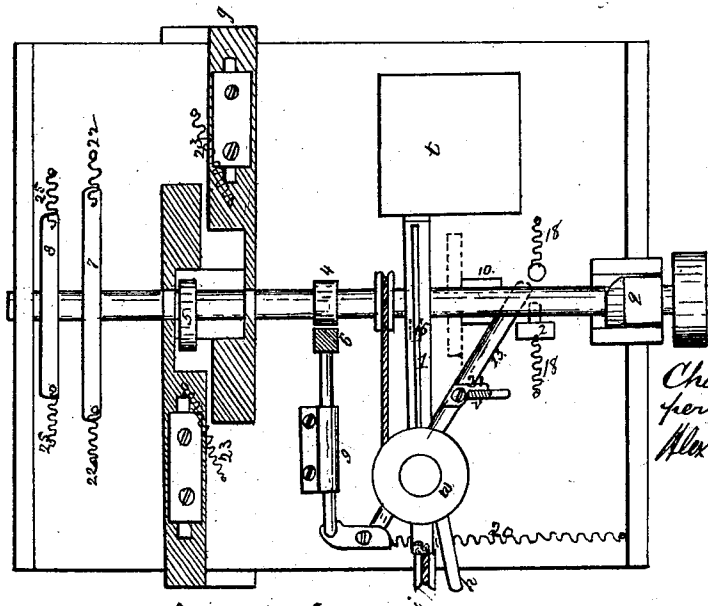

Fig. 4.

Witnesses.
 C. L. Ewert.
 A. H. Mart

Inventor.
 Chas. C. Wilson
 per
 Alexander Mason
 attys.

United States Patent Office.

CHARLES C. WILSON, OF BALTIMORE, MARYLAND.

Letters Patent No. 110,812, dated January 3, 1871.

IMPROVEMENT IN MACHINES FOR WRAPPING "KISSES," &c.

The Schedule referred to in these Letters Patent and making part of the same.

To all whom it may concern.

Be it known that I, CHARLES C. WILSON, of Baltimore, in the county of Baltimore and in the State of Maryland, have invented certain new and useful Improvements in Machines for Wrapping Kisses, &c.; and do hereby declare that the following is a full, clear, and exact description thereof, reference being had to the accompanying drawing and to the letters of reference marked thereon making a part of this specification.

The nature of my invention consists in the construction and arrangement of a machine for wrapping candy kisses or other articles, as will be hereinafter fully set forth.

In order to enable others skilled in the art to which my invention appertains to make and use the same, I will now proceed to describe its construction and operation, referring to the annexed drawing, in which—

Figure 1 is a plan view of my machine;

Figure 2 is a transverse vertical section of the same through the line A B, fig. 1;

Figure 3 is a side view; and

Figure 4, a bottom view of the machine.

A represents the table or bed of my machine, supported at any desired height from the floor.

B is the driving-shaft, running longitudinally under the bed A, and turned by means of a crank at one end, or by a belt connecting any engine or power with a pulley on the shaft.

14 is the hopper through which the kisses or other articles are fed, and fall in succession, one after the other, under the front center plunger *a* and between the front side plungers *b b*.

These plungers are, by vertical rods, connected with a horizontal carrier, *s*, and are arranged in the following manner:

The side plungers *b b* are on a level, or at the same height, while the center plunger *a* is so much higher up above the side plungers as the thickness of the kiss or other article to be wrapped.

Previous to the kiss falling down under the plunger *a* the paper which is to be wrapped around it is drawn under the three plungers. This paper, being first cut the proper size, is placed flat in the box *t*, which is provided with a spring-bottom, so as to force the pile of paper upward against the two suckers, *o o*, placed above and at the inner edge of the paper feed-box *t*.

The suckers *o o* are hollow, with holes or apertures at their lower sides, and are attached to horizontal pipes, *e e*, connected together, as shown in fig. 1, and moving in stationary guides above the bed-plate A.

The pipes *e e* are, by a flexible tube, *h*, connected with an air-pump, *w*.

The piston-rod of the air-pump *w* is pivoted to a lever, 1, which is pivoted at its inner end, as shown in fig. 2, while the outer or rear end of said lever is, by a belt or cord, connected with the pipes *e e*, said belt or cord passing over the roller *i*.

The shaft B being turned, a cam, 15, on the same, operates the lever 1, which thus operates in a two-fold manner.

By means of the air-pump it creates a suction in the suckers *o o*, making the top piece of paper in the box *t* adhere to their under faces, and, at the same time, it draws the pipes *e e*, with the sucker and adhering paper, across the bed so as to bring the paper immediately under the plungers *b b*.

As soon as the cam 15 ceases to operate on the lever 1, the suction ceases, dropping the paper, and at the same time springs, 16 16, attached to the suckers, as shown in figs. 1 and 2, draw them, with the pipes *e e*, back in their original position, causing the lever 1 also to resume its former place, to be again acted upon at the next revolution of the shaft.

On the opposite side of the bed-plate A from the paper-feed box *t*, in suitable bearings, is a wheel or roller, *k*, having the mottoes usually wrapped up with candy kisses wound around it.

The motto *u* passes from said wheel *k* between two elastic feed-rollers, *l l*, which are operated by means of a cord or belt from a pulley on the shaft B.

The motto is fed in at the same time as the paper is drawn in under the plungers *b b*, and at the proper time it is cut off by the scissors *v*. The mechanism for operating these scissors will be presently described.

The horizontal carrier *s*, to which the plungers *a* and *b b* are connected, as above set forth, is attached to two vertical rods, which pass down through the bed-plate A, and one of which rods is, below said bed-plate, provided with a head or catch, 2.

This catch is operated upon by a cam, 17, on the shaft B, so as to force the carrier *s*, with the plungers, vertically downward.

This brings the kiss and paper down through a rectangular opening at the front end of a box, 12, secured on the top of the bed-plate, the sides of the paper being by this movement bent upward at right angles.

The instant this has been accomplished the cam 17 escapes from the catch 2, and springs, 18 18, throw the carrier *s*, with the plungers *a b b*, suddenly and quickly upward again to their former position.

As soon as these plungers have thus been suddenly brought out of the way a side plunger, *p*, moves inward, folding the right side of the paper over on top of the kiss. This plunger is then suddenly withdrawn, and at the same time, or a little previous, a carrier, 10, pushes the kiss through the box 12 to the other

end thereof, this movement causing the left side of the paper to be folded over the kiss and lap over the edge of the already folded right side of the paper.

The plunger *p* is attached to a bent plate, *q*, passing around the right end of the bed-plate *A*, and sliding in guides on the under side of the same.

On the under side of this plate is a friction-roller, operated upon by the cam 3, on the shaft *B*, to force the plunger *p* inward for the purpose above mentioned.

The plunger *p* is moved back by springs 19 19.

The carrier 10, which pushes the kiss through to the other end of the box 12, has an arm extending through a longitudinal slot in the bed-plate *A*, which arm is provided with a loop. Through this loop passes the long end of a bent lever, 13, pivoted on the under side of the bed-plate, while the short end of said lever is connected with a rod, 9, moving in a stationary guide on the under side of the bed-plate.

On the inner end of the rod 9 is a finger, 6, which is operated upon by a cam, 4, on the shaft *B*. The operation of this mechanism is to move the carrier 10 forward for the purposes mentioned.

As soon as the cam 4 escapes from the finger 6 a spring, 20, attached to the lever 13, as shown in fig. 4, throws said lever, with the carrier, suddenly and quickly back in their original position.

On the lever 13 is a projection, 21, which, when said lever is by the spring 20, as above described, thrown suddenly back, operates upon the scissors *v* to cut off the motto. A spring should be attached to said scissors to open them when the lever 13 is moved forward.

The kiss, with the paper folded on both sides, being pushed through the box 12, is deposited under the back center plunger *c* and back side plungers *d d*.

The side plungers *d d* are constructed as shown in fig. 1, that is, almost in the shape of a triangle, their inner edges being the base. These plungers are connected with a plate having bent rods, *m m*, passing through the bed-plate and connected at their lower ends by a cross-bar, 7, which passes immediately below the shaft *B*. A cam on said shaft operates the cross-bar 7 so as to force the plungers *d d* downward, the object of which is to press the ends of the folded paper together at the ends of the kiss, leaving on each side a triangular piece, which, from the action of the plunger, will naturally bend slightly upward.

While the plungers *d d* are yet moving downward, and before they have completed their downward stroke, two other cams, 5, on the shaft *B*, commence to operate upon slides *g g*, one on each side of the back plungers, forcing said slides inward. These slides, moving inward, operate each upon one pair of side folders, *f f*, which are so arranged that, at the instant the plungers *d d* complete their downward stroke, they will catch on and fold the triangular pieces of paper untouched by the plungers.

Springs, 22 22, attached to the cross-bar 7, throw the plungers *d d* upward again as soon as the cam has passed said cross-bar.

As soon as the cams 5 5 cease to operate on the slides *g g*, springs, 23, throw the slides back again, and other springs, 24, open the folders *f f*.

The back center plunger *c* is attached to a bent rod, *m'*, which passes down through the bed-plate, and is

attached to a frame, 8. This frame is also operated upon by a cam on the shaft *B* so as to force the plunger *c* downward when the folders *f* have commenced to return. This movement of the plunger *c* forces the wrapped kiss through an aperture in the bed-plate *A*, which has the effect of bending the folded ends of the paper upward in shape, when the kiss falls out completed.

A spring or springs, 25, attached to the frame 8, force the plunger *c* up again as soon as it has forced the kiss through.

It will, of course, be understood that when the carrier 10 returns to its first position after having deposited the kiss under the back plungers, the operation is commenced anew at this end of the machine, while the first kiss is completed by the back plungers, as just described.

I do not confine myself to the particular mechanisms herein described for operating the various devices by which the paper is folded around a kiss, or carried from one place to another, as they may, of course, be varied without materially changing the operation of said devices.

Other articles that have to be wrapped in paper may be wrapped in the same manner, by changing the size of the various parts composing my machine.

Having thus fully described my invention,

What I claim as new, and desire to secure by Letters Patent, is—

1. The air-pump *w*, flexible tube *h*, movable pipes *s s*, and suckers *o o*, or their equivalents, for feeding paper by suction, as herein set forth.
2. The lever 1 and cam 15, arranged as described, for operating the air-pump *w* and feeding mechanism *e o*, substantially as set forth.
3. In combination with the feeding mechanism *e o*, the springs 16 16, for the purposes set forth.
4. The arrangement of the wheel *k*, elastic feed-rollers *l l*, and scissors *v*, for feeding and cutting off the mottoes, substantially as herein set forth.
5. The front plungers *a* and *b b*, constructed and arranged to operate substantially as and for the purposes herein set forth.
6. The plunger *p*, constructed and arranged to operate substantially as and for the purposes herein set forth.
7. The carrier 10, constructed and arranged to operate substantially as and for the purposes herein set forth.
8. The triangular plungers *d d*, constructed and arranged to operate substantially as and for the purposes herein set forth.
9. The folders *f f*, constructed and arranged substantially as and for the purposes herein set forth.
10. The back center plunger *c*, arranged to operate substantially as and for the purposes herein set forth.

In testimony that I claim the foregoing I have hereunto set my hand this 5th day of November, 1870.

CHARLES C. WILSON.

Witnesses:

A. N. MARR,
C. L. EVERT.