

No. 656,752.

Patented Aug. 28, 1900.

H. SOMMERFELD.
FAN MOTOR.

(Application filed July 11, 1899.)

(No Model.)

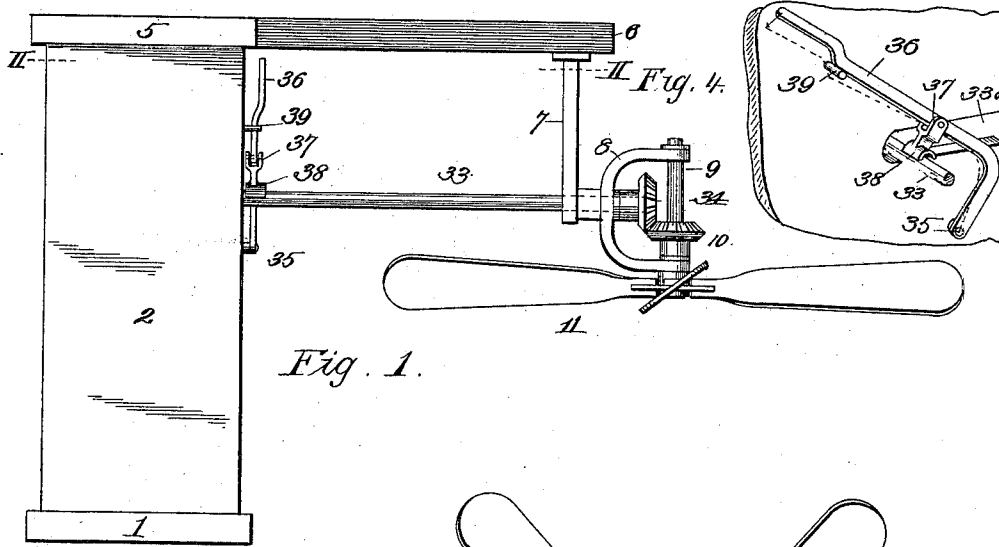

Fig. 1.

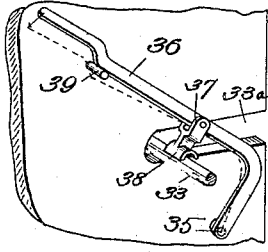

Fig. 4.

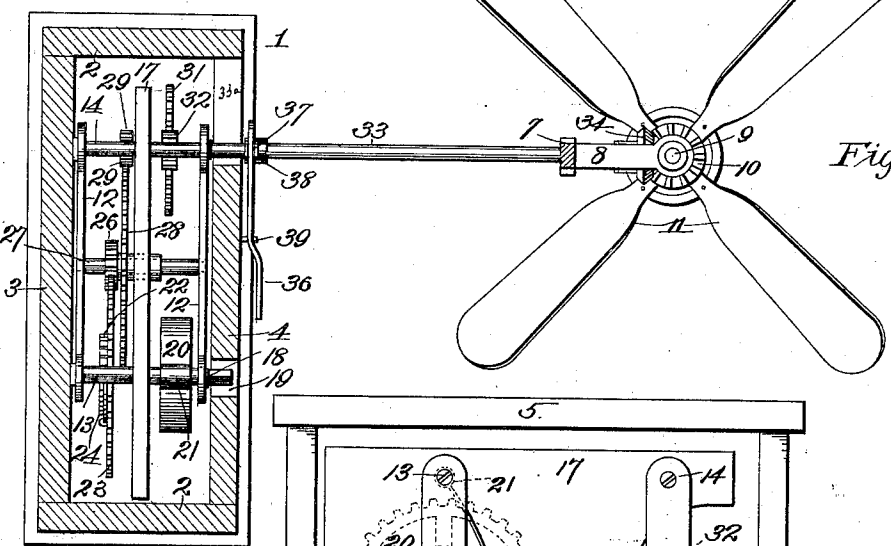

Fig. 2.

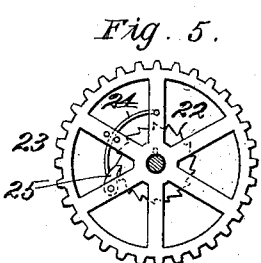

Fig. 5.

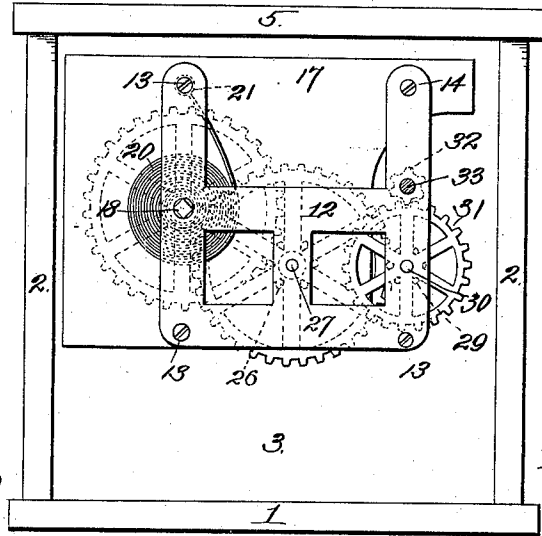

Fig. 3.

Witnesses:
H. C. Rodgers
M. R. Remley.

Inventor:
H. Sommerfeld

By August Fischer & Sonpe
attys

UNITED STATES PATENT OFFICE.

HEINRICH SOMMERFELD, OF CANTON, KANSAS, ASSIGNOR OF ONE-HALF
TO JUSTUS SCHROEDER, OF KANSAS CITY, MISSOURI.

FAN-MOTOR.

SPECIFICATION forming part of Letters Patent No. 656,752, dated August 28, 1900.

Application filed July 11, 1899. Serial No. 723,456. (No model.)

To all whom it may concern:

Be it known that I, HEINRICH SOMMERFELD, of Canton, McPherson county, Kansas, have invented certain new and useful Improvements in Fan-Motors, of which the following is a specification.

My invention relates to fan-motors; and my object is to produce a device of this character which is portable, so that it may be removed from one room of the house to another, and which is of simple, strong, durable, and cheap construction.

To this end the invention consists in certain novel and peculiar features of construction and combinations of parts, as hereinafter described and claimed, and in order that it may be fully understood reference is to be had to the accompanying drawings, in which—

Figure 1 represents a side view of a portable fan-motor embodying my invention. Fig. 2 is a horizontal section taken on the dotted line II II of Fig. 1. Fig. 3 is a front view with the front wall of the casing omitted and showing the shaft geared directly to the fan-shaft in section. Fig. 4 is a perspective view showing the brake-lever for arresting the movement of the fan. Fig. 5 is a view showing the drive-shaft in section and a front view of the gearing mounted thereon.

Referring to the drawings in detail, 1 designates a motor-supporting case; 2, the side walls; 3, the back wall; 4, the front wall, and 5 the top, the latter having forward an extending carrying-beam 6, carrying a depending arm 7 near its outer end, and formed with or secured to said hanger is a yoke 8, in which is journaled the short vertical shaft 9, a bevel gear-wheel 10 and a fan 11 being secured rigidly on said shaft, the former within and the latter below said yoke. This casing is adapted to be secured to a wall or other support in any suitable or preferred manner.

The frame proper of the motor is constructed as follows: 12 12 designate a pair of parallel and substantially U-shaped frames connected at their four corners by the cross-rods 13 in the manner common in clockwork mechanism or in any other suitable or preferred manner, and secured upon said cross-rods, so as to centrally partition said frame, by preference is a partition 17. 18 designates

the power-shaft extending through said partition and journaled at its opposite ends in the frames 12, the front end of said shaft being rectangular in cross-section and projecting into the hole 19 of the front wall of the casing in order that it may be readily turned by means of a key when it is desired to rewind the coil-spring 20, mounted upon the shaft and secured at its inner end thereto and at its outer end, as at 21, to the cross-rod 13, vertically above said shaft. Secured rigidly on the shaft at the opposite side of partition 17 is a ratchet-wheel 22, and journaled on the shaft adjacent to said ratchet-wheel is a large gear-wheel 23, carrying the spring 24 and a pivoted pawl 25, the spring holding said pawl yieldingly in engagement with the ratchet-wheel in order that movement imparted to the shaft by the spring 20 may be transferred by the ratchet-wheel to said gear-wheel. Said gear-wheel 23 meshes with a pinion 26, journaled upon the stationary shaft 27, and formed integral with or secured to said pinion 26 is a gear-wheel 28, meshing with a pinion 29, journaled upon the short stationary shaft 30 of the frame, and said pinion 29 is formed integral with or secured in any suitable manner to the gear-wheel 31, which meshes with the pinion 32, mounted rigidly on an extending shaft 33, journaled in the frame and near its front end in the yoke 8 and carrying rigidly a bevel-gear 34, which meshes with the bevel-gear 10 upon the fan-shaft, as hereinbefore explained. In order to accommodate this shaft 33, the front wall of the casing is slotted, as shown at 33^a, said slot extending to the adjacent edge of said front wall in order that said wall may be removed in case it is necessary to have access to the interior mechanism and it is not desired to dismantle the entire casing.

In order to arrest the movement of the fan at any time, I pivot to the front wall, as at 35, the angle-lever 36, and pivoted to said lever is a link 37, terminating in a segmental brake-shoe 38, which engages the shaft 33 or not, accordingly as the lever is disposed below or above the pin 39, projecting from the front wall. When the lever rests upon the pin, as shown in Fig. 4, the brake-shoe is above and out of contact with the shaft 33. When the

lever is disposed below the plane of and pushed under the pin, it is held by the latter, with the shoe 38 frictionally engaging the shaft 33 and holding the same stationary.

5 The operation of the device when the spring is wound up is obvious, its movement being controlled entirely by the position of the controlling-lever 36, as will be readily understood. In such operation the spring causes
10 the ratchet-wheel 22 by engagement with the pawl 25 to operate the fan. When the spring is rewound, it is obvious that the wheel turns in the opposite direction, and consequently slips inoperatively past the pawl, and thereby
15 does not affect the position of the fan.

From the above description it will be apparent that I have produced a fan which embodies the features of advantage enumerated as desirable in the statement of invention
20 and which may be varied in minor particulars without departing from the spirit and scope of the invention.

Having thus described the invention, what

I claim as new, and desire to secure by Letters Patent, is—

25 The combination of a motor-supporting case 1, containing a suitable motor, a carrying-beam 6, extending from said case, a depending arm 7 rigidly secured to said beam, a
30 yoke 8, secured at its closed end to arm 7, a shaft 33, actuated by said motor and journaled near its outer end in the closed portion of yoke 8, a vertical shaft 9 journaled in the
35 arms of said yoke, bevel gear-wheels 10 and 34 secured on shafts 9 and 33 respectively, a bent brake-lever 36, pivotally secured to the motor-case below shaft 33, and a link 37, pivoted to said lever and terminating in a brake-
shoe 38, substantially as described.

In testimony whereof I affix my signature
40 in the presence of two witnesses.

HEINRICH SOMMERFELD.

Witnesses:

C. H. WAY,
C. W. PERSINGER.