

Feb. 6, 1945.

P. W. CRIST ET AL

2,368,746

LIQUID HANDLING APPARATUS

Filed Dec. 31, 1942

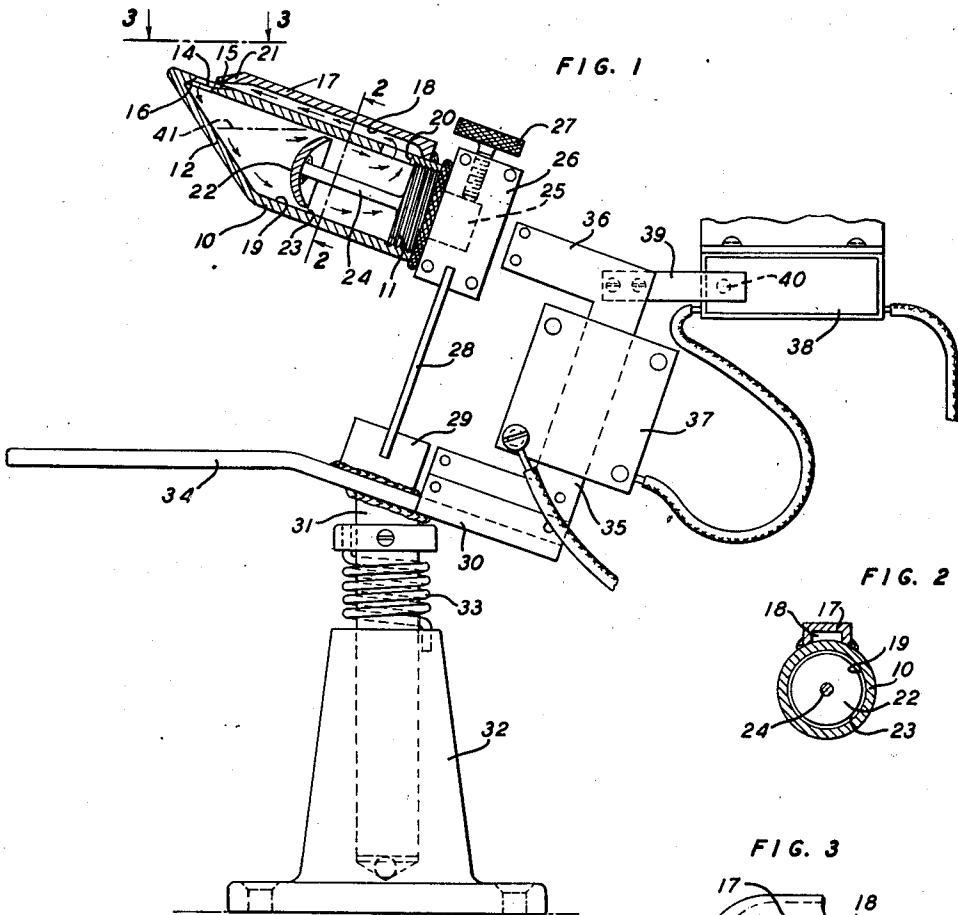

FIG. 1

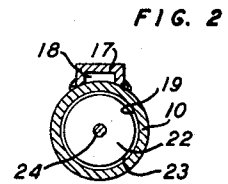

FIG. 2

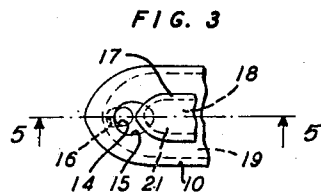

FIG. 3

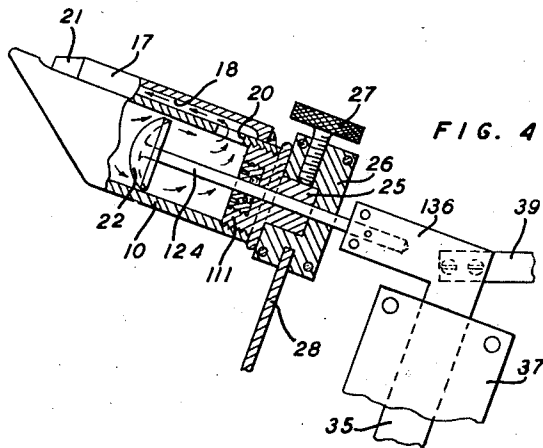

FIG. 4

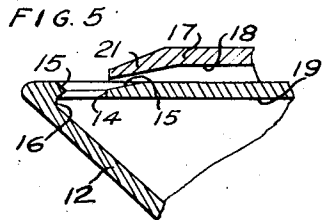

FIG. 5

INVENTORS
P.W. CRIST
S.G. JOHANSSON
BY
E.R. Nowell
INVENTOR

UNITED STATES PATENT OFFICE

2,368,746

LIQUID HANDLING APPARATUS

Philip W. Crist, Roselle Park, and Sven G. Johansson, Cranford, N. J., assignors to Western Electric Company, Incorporated, New York, N. Y., a corporation of New York

Application December 31, 1942, Serial No. 470,889

3 Claims. (Cl. 259-94)

This invention relates to liquid handling apparatus, and more particularly to apparatus for churning a liquid suspension of finely divided solid matter and presenting a continuously flowing portion thereof of uniform consistency for removal in small quantities for use.

There are innumerable instances in various arts where use is made of finely divided solid matter suspended in a liquid and having a more or less great tendency to settle out of the liquid when allowed to remain undisturbed. For example, in the manufacture of the silver coated sections of crystalline quartz employed in various forms of high frequency electrical apparatus, it is sometimes the case that it is necessary to provide an extra thickness of silver in the silver films or coatings over a small and carefully located portion of the area of a film, to which thickened portion of the film a connector wire is to have its end butt-welded or soldered. This may be done by dipping a predetermined length of the end of the connector wire into a suitable liquid suspension of finely divided metallic silver with an admixture of powdered lead borate in a suitable vehicle, and then applying the end of the wire carrying a modicum of the silver suspension adherent thereto, to the pre-selected location on the quartz plate, and applying heat to fuse the silver to the quartz by the action of the lead borate. Obviously, it is highly preferable that the pool, reservoir or stream of the suspension into which the wire end is dipped, shall be of uniform consistency at each repetition of the operation in order that the resultant joints may be uniform.

An object of the present invention is to provide a device to contain a body of liquid and to churn and circulate the same in such fashion as to present a circulating portion thereof of uniform consistency, and having means whereby the churning action may be interrupted at will when it is desired to remove a modicum of the uniform suspension from the circulated portion thereof.

With the above and other objects in view, the invention may be embodied in a device comprising a reservoir to contain a body of liquid and formed with a channel external to one wall thereof, means within the reservoir to both churn the liquid and to circulate a stream of the liquid from and back to the main body of liquid through the channel, and controllable means to actuate the churning and circulating means.

Other objects and features of the invention will appear from the following detailed descrip-

tion of one embodiment thereof taken in connection with the accompanying drawing, in which the same reference numerals are applied to identical parts in the several figures and in which

Figure 1 is a view in side elevation and partly in vertical section of an apparatus constructed in accordance with the invention;

Fig. 2 is a section on the line 2-2 of Fig. 1;

Fig. 3 is a partial plan view of the portion indicated at 3-3 in Fig. 1;

Fig. 4 is a view similar to a part of Fig. 1 of a modified form; and

Fig. 5 is an enlarged section on the line 5-5 of Fig. 3.

Considering now particularly Figs. 1, 2 and 3, the apparatus comprises a reservoir 10, here shown as a hollow cylinder or tube, closed at its right end by a screw plug 11 and at its left end by a flat, slantingly transverse wall 12. Near the tip of the ovally rounded point thus formed at the left end of the upper side of the cylindrical reservoir, there is a small perforation 14, preferably dished out at the right side of its outer end as shown at 15 and dished out at the left side of its inner end as indicated at 16. Along the top of the reservoir is secured a channel member 17 defining a longitudinal, laterally enclosed passageway or channel 18, which communicates with the interior chamber 19 of the reservoir 10 at the right by means of an aperture 20 in the reservoir wall. At the left, the end of the member 17 overhangs the dish 15 of the aperture 14 to allow the channel 18 to communicate with the chamber 19 through the aperture 14 also. Preferably member 17 is drawn down into a nose 21 to provide a vertically narrow and laterally relative wide outlet of the channel 17 to the aperture 14, so that liquid passing from the channel into the dish 15 will flow in a thin horizontal sheet.

A churning member 22, in form like a deeply concavo-convex lens, is located within the chamber 19, transversely across the same about at the middle thereof, with its convex face to the left. The diameter of the member 22 is slightly less than that of the chamber 19, so that there is an annular passage 23 between the member 22 and the wall of the chamber 19. The member 22 is rigidly mounted on the left end of an axial stem 24 whose right end is rigidly attached to the plug 11.

The outer face of the plug 11 bears an integral or rigidly attached extension or tenon 25 fittable into a corresponding recess formed in a block or armature 26 of magnetic material, and removably secured in place by a jam screw 27. The

block 26 is rigidly mounted on the upper end of a relatively stiff, spring support 28 whose lower end is rigidly mounted in a block 29 secured on the upper face of a turntable 30. The turntable 30 in turn is rigidly secured on the upper end of a vertical shaft 31 rotatably supported in a suitable base member 32. A coil spring 33 tends to turn the shaft 31 and therewith the table 30 counterclockwise as seen from above. The turntable is provided with a handle lever 34 by which the table may be turned against the effect of the spring 33. The turntable is permanently tilted from the horizontal, as shown, so that the axis of the cylindrical reservoir 10 is similarly permanently tilted to bring the left ends of the chamber 19 and channel 18 above their right ends.

An electromagnet 35 is rigidly mounted on the table 30 with one pole 36 in proximity to the armature 26. The winding 37 of the armature is connected through a switch 38 to any suitable source (not shown) of suitably alternating or pulsating electrical current. A lever arm 39 rigidly secured on the table 30 by means of the magnet 35 serves to actuate the control button or member 40 of the switch 38. The switch device 38 is so arranged that, when no force is exerted on the handle 34 and the spring 33 is free to act, the lever arm 39 will then press against the button 40 to actuate the latter to close the circuit through the winding 37 of the magnet, and when the arm 39 is moved away from the button 40 by manual or other pressure on the lever 34, the circuit through the magnet winding will be interrupted until the button 40 is again pressed by the arm 39.

Hence, when the apparatus is as shown in Fig. 1, the magnet having its winding continuously fed with alternating or pulsating current, exerts a pulsating attraction on the armature 26 which is thus caused to have a rapid vibratory motion on its elastic support 28. The reservoir 10 is thus given the same vibratory motion, being reciprocated rapidly to and fro in the direction of its axis, together with the combination churning and pumping member 22. The reservoir 10 is filled with the liquid in question, preferably to about the level indicated at 41. Owing to the inertia of the body of liquid, the effect of the vibratory motion of the reservoir 10 and member 22 is to churn the liquid thoroughly and also, because of the concavo-convex shape of the member 22, to propel or pump the liquid as indicated by the arrows. This causes the liquid to be kept thoroughly mixed and to be continuously circulated, as indicated, from the chamber 19, up through the aperture 20, up along the channel 18, and out from under the nose 21 in a flat thin uniform sheet to the aperture 14, and so back into the chamber 19.

When it is desired to dip a stylus, wire end, or other like member into the liquid to pick up a predeterminedly constant amount of liquid of uniform consistency, the lever 34 is pushed (away from the beholder in Fig. 1). The strong vibration of the device is thus halted; but the flow of liquid from under the nose 21 continues, because of the inertia of the circulating liquid, long enough to keep the dish 15 full until the end of the stylus, wire or the like can be dipped and removed. On releasing the lever 34, the table

swings back to the position shown and the churning and circulation of the liquid are resumed.

Where the specific gravity of the liquid in question is relatively high, the arrangement as above described may be preferred. However, if both the liquid and its solid burden are light, they may partake of the vibration of the reservoir and thus diminish the effectiveness of the churning and pumping actions. In such case it may be preferred, as shown in Fig. 4, to carry the stem 124 of the member 22 through the screw plug 111 and attach it rigidly to the pole 136 of the magnet 35. In operation, the member 22 will then be held stationary while the reservoir 10 and its contents are moved to and fro relatively to the member.

Other modifications and adaptations may well be made from the illustrative embodiments disclosed while still remaining within the spirit and scope of the invention as pointed out and described in the appended claims.

What is claimed is:

1. Apparatus to contain a body of liquid and to churn the same and to present accessibly a circulated portion thereof of uniform consistency, the said apparatus comprising a reservoir to contain a body of liquid in the chamber thereof and formed with a dish in the outer surface of the top wall thereof and communicating with the said chamber and further formed with an enclosed channel communicating between the said chamber and the said dish, a churning and pumping member positioned in the said chamber, and means to reciprocate the reservoir to cause the member to churn the liquid and pump the same to circulate through the channel and the dish.

2. Apparatus to contain a body of liquid and to churn the same and to present accessibly a circulated portion thereof of uniform consistency, the said apparatus comprising a reservoir to contain a body of liquid in the chamber thereof and formed with a dish in the outer surface of the top wall thereof and communicating with the said chamber and further formed with an enclosed channel communicating between the said chamber and the said dish, a churning and pumping member positioned in the said chamber, and means to reciprocate the reservoir relatively to the member to cause the member to churn the liquid and pump the same to circulate through the channel and the dish.

3. Apparatus to contain a body of liquid and to churn the same and to present accessibly a circulated portion thereof of uniform consistency, the said apparatus comprising a reservoir to contain a body of liquid in the chamber thereof and formed with a dish in the outer surface of the top wall thereof and communicating with the said chamber and further formed with an enclosed channel communicating between the said chamber and the said dish, a churning and pumping member positioned in the said chamber, and means to reciprocate the reservoir and the member to cause the member to churn the liquid and pump the same to circulate through the channel and the dish.

PHILIP W. CRIST.
SVEN G. JOHANSSON.