

(19) World Intellectual Property Organization  
International Bureau



(43) International Publication Date  
19 July 2007 (19.07.2007)

PCT

(10) International Publication Number  
WO 2007/081756 A3

- (51) International Patent Classification:  
H04N 7/26 (2006.01) H04N 13/00 (2006.01)  
H04N 7/36 (2006.01)
- (21) International Application Number:  
PCT/US2007/000199
- (22) International Filing Date: 8 January 2007 (08.01.2007)
- (25) Filing Language: English
- (26) Publication Language: English
- (30) Priority Data:  
60/757,289 9 January 2006 (09.01.2006) US
- (71) Applicant (for all designated States except US): THOMSON LICENSING [FR/FR]; 46, quai A. Le Gallo, F-92100 Boulogne-Billancourt (FR).
- (72) Inventors; and
- (75) Inventors/Applicants (for US only): SU, Yeping [CN/US]; 2707 Hunters Glen Drive, Plainsboro, NJ 08536 (US). YIN, Peng [CN/US]; 5508 Hunters Glen Drive, Plainsboro, NJ 08536 (US). GOMILA, Cristina [ES/US]; 25C Chestnut Court, Princeton, NJ 08540 (US).

- (74) Agents: LAKS, Joseph, J. et al.; Thomson Licensing LLC, Two Independence Way, Suite #200, Princeton, NJ 08540 (US).
- (81) Designated States (unless otherwise indicated, for every kind of national protection available): AE, AG, AL, AM, AT, AU, AZ, BA, BB, BG, BR, BW, BY, BZ, CA, CH, CN, CO, CR, CU, CZ, DE, DK, DM, DZ, EC, EE, EG, ES, FI, GB, GD, GE, GH, GM, GT, HN, HR, HU, ID, IL, IN, IS, JP, KE, KG, KM, KN, KP, KR, KZ, LA, LC, LK, LR, LS, LT, LU, LV, LY, MA, MD, MG, MK, MN, MW, MX, MY, MZ, NA, NG, NI, NO, NZ, OM, PG, PH, PL, PT, RO, RS, RU, SC, SD, SE, SG, SK, SL, SM, SV, SY, TJ, TM, TN, TR, TT, TZ, UA, UG, US, UZ, VC, VN, ZA, ZM, ZW.
- (84) Designated States (unless otherwise indicated, for every kind of regional protection available): ARIPO (BW, GH, GM, KE, LS, MW, MZ, NA, SD, SL, SZ, TZ, UG, ZM, ZW), Eurasian (AM, AZ, BY, KG, KZ, MD, RU, TJ, TM), European (AT, BE, BG, CH, CY, CZ, DE, DK, EE, ES, FI, FR, GB, GR, HU, IE, IS, IT, LT, LU, LV, MC, NL, PL, PT, RO, SE, SI, SK, TR), OAPI (BF, BJ, CF, CG, CI, CM, GA, GN, GQ, GW, ML, MR, NE, SN, TD, TG).

Published:  
— with international search report

[Continued on next page]

(54) Title: METHODS AND APPARATUSES FOR MULTI-VIEW VIDEO CODING

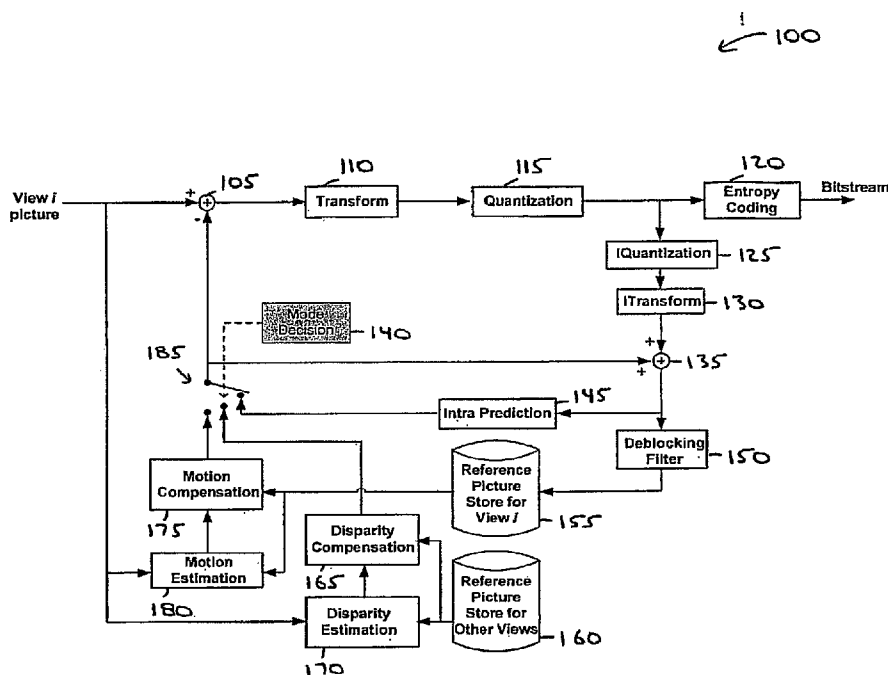

(57) Abstract: There are provided methods and apparatus for multi-view video coding. A video encoder includes an encoder (100) for encoding a block in a picture by choosing between temporal prediction and cross-view prediction to enable a prediction for the block. The picture is one of a set of pictures corresponding to multi-view video content and having different view points with respect to a same or similar scene. The picture represents one of the different view points. A high-level syntax is used to indicate the use of cross-view prediction for the block.

WO 2007/081756 A3



— *before the expiration of the time limit for amending the claims and to be republished in the event of receipt of amendments*

*For two-letter codes and other abbreviations, refer to the "Guidance Notes on Codes and Abbreviations" appearing at the beginning of each regular issue of the PCT Gazette.*

**(88) Date of publication of the international search report:**

3 January 2008

**INTERNATIONAL SEARCH REPORT**

International application No  
PCT/US2007/000199

<b>A. CLASSIFICATION OF SUBJECT MATTER</b> INV. H04N7/26 H04N7/36 H04N13/00		
According to International Patent Classification (IPC) or to both national classification and IPC		
<b>B. FIELDS SEARCHED</b>		
Minimum documentation searched (classification system followed by classification symbols) H04N		
Documentation searched other than minimum documentation to the extent that such documents are included in the fields searched		
Electronic data base consulted during the international search (name of data base and, where practical, search terms used) EPO-Internal, INSPEC		
<b>C. DOCUMENTS CONSIDERED TO BE RELEVANT</b>		
Category*	Citation of document, with indication, where appropriate, of the relevant passages	Relevant to claim No.
X	YIP P Y ET AL: "Joint source and channel coding for h.264 compliant stereoscopic video transmission" ELECTRICAL AND COMPUTER ENGINEERING, 2005. CANADIAN CONFERENCE ON SASKATOON, SK, CANADA MAY 1-4, 2005, PISCATAWAY, NJ, USA, IEEE, 1 May 2005 (2005-05-01), pages 188-191, XP010868784 ISBN: 0-7803-8885-2 pages 188-190, paragraph 1 - paragraph 3 figure 2	1-6, 11-16, 21-26, 31-36, 41-46
Y	----- -/--	7,17,27, 37
<input checked="" type="checkbox"/> Further documents are listed in the continuation of Box C. <span style="margin-left: 200px;"><input type="checkbox"/> See patent family annex.</span>		
* Special categories of cited documents :		
*A* document defining the general state of the art which is not considered to be of particular relevance *E* earlier document but published on or after the international filing date *L* document which may throw doubts on priority claim(s) or which is cited to establish the publication date of another citation or other special reason (as specified) *O* document referring to an oral disclosure, use, exhibition or other means *P* document published prior to the international filing date but later than the priority date claimed		*T* later document published after the international filing date or priority date and not in conflict with the application but cited to understand the principle or theory underlying the invention *X* document of particular relevance; the claimed invention cannot be considered novel or cannot be considered to involve an inventive step when the document is taken alone *Y* document of particular relevance; the claimed invention cannot be considered to involve an inventive step when the document is combined with one or more other such documents, such combination being obvious to a person skilled in the art. *&* document member of the same patent family
Date of the actual completion of the international search  <p align="center">12 July 2007</p>		Date of mailing of the international search report  <p align="center">15/11/2007</p>
Name and mailing address of the ISA/ European Patent Office, P.B. 5818 Patentlaan 2 NL - 2280 HV Rijswijk Tel. (+31-70) 340-2040, Tx. 31 651 epo nl, Fax: (+31-70) 340-3016		Authorized officer  <p align="center">Lombardi, Giancarlo</p>

## INTERNATIONAL SEARCH REPORT

International application No  
PCT/US2007/000199

C(Continuation). DOCUMENTS CONSIDERED TO BE RELEVANT		
Category*	Citation of document, with indication, where appropriate, of the relevant passages	Relevant to claim No.
Y	"TEXT OF COMMITTEE DRAFT OF JOINT VIDEO SPECIFICATION (ITU-T REC. H-264 ISO/IEC 14496-10 AVC) MPEG02/N4810" ISO/IEC JTC1/SC29/WG11 MPEG02/N4810, FAIRFAX, US, May 2002 (2002-05), pages 104-105, XP002442280 pages 104-105, paragraph 11.4.1	7, 17, 27, 37
A		1-6, 11-16, 21-26, 31-36, 41-46
X	----- CHEN G; KIM J H; LOPEZ J; ORTEGA A: "Response to Call for Evidence on Multi-View Video Encoding" INTERNATIONAL ORGANISATION FOR STANDARDISATION, ISO/IEC JTC1/SC29/WG11, CODING OF MOVING PICTURES AND AUDIO, HONG KONG, CHINA, JANUARY 2005, vol. MPEG2005/M11731, no. PROPOSAL, January 2005 (2005-01), pages 1-4, XP002442281 the whole document	1-6, 11-16, 21-26, 31-36, 41-46
A		7, 17, 27, 37
X	----- ADIKARI A B B ET AL: "A H.264 compliant stereoscopic video codec" ELECTRICAL AND COMPUTER ENGINEERING, 2005. CANADIAN CONFERENCE ON SASKATOON, SK, CANADA MAY 1-4, 2005, PISCATAWAY, NJ, USA, IEEE, 1 May 2005 (2005-05-01), pages 1622-1625, XP010869087 ISBN: 0-7803-8885-2 the whole document	1-6, 11-16, 21-26, 31-36, 41-46
A		7, 17, 27, 37

# INTERNATIONAL SEARCH REPORT

International application No.  
PCT/US2007/000199

## Box II Observations where certain claims were found unsearchable (Continuation of item 2 of first sheet)

This International Search Report has not been established in respect of certain claims under Article 17(2)(a) for the following reasons:

1.  Claims Nos.:  
because they relate to subject matter not required to be searched by this Authority, namely:
  
2.  Claims Nos.:  
because they relate to parts of the International Application that do not comply with the prescribed requirements to such an extent that no meaningful International Search can be carried out, specifically:
  
3.  Claims Nos.:  
because they are dependent claims and are not drafted in accordance with the second and third sentences of Rule 6.4(a).

## Box III Observations where unity of invention is lacking (Continuation of item 3 of first sheet)

This International Searching Authority found multiple inventions in this international application, as follows:

see additional sheet

1.  As all required additional search fees were timely paid by the applicant, this International Search Report covers all searchable claims.
2.  As all searchable claims could be searched without effort justifying an additional fee, this Authority did not invite payment of any additional fee.
3.  As only some of the required additional search fees were timely paid by the applicant, this International Search Report covers only those claims for which fees were paid, specifically claims Nos.:
  
4.  No required additional search fees were timely paid by the applicant. Consequently, this International Search Report is restricted to the invention first mentioned in the claims; it is covered by claims Nos.:

see annex

### Remark on Protest

- The additional search fees were accompanied by the applicant's protest.
- No protest accompanied the payment of additional search fees.

**FURTHER INFORMATION CONTINUED FROM PCT/ISA/ 210**

This International Searching Authority found multiple (groups of) inventions in this international application, as follows:

1. claims: 1-7,11-17,21-27,31-37,41-46

Apparatus for multiview video encoding, where temporal prediction by means of motion type vectors and cross-view prediction by means of disparity type vectors are used, each vector being encoded in a block using as predictor only vectors from neighboring blocks containing vectors of the same type.

---

2. claims: 1,8,9,11,18,19,21,28,29,31,38,39

Apparatus for multiview video encoding, where temporal prediction by means of motion type vectors and cross-view prediction by means of disparity type vectors are used, where both types of vector are encoded for a single block.

---

3. claims: 10,20,30,40,47,48

Apparatus for multiview video encoding, where cross-view prediction by means of disparity type vectors are used, where the disparity vector is temporally encoded based at least on the disparity vector of a temporally co-located block and of a neighbouring block of said temporally co-located block.

---