

June 29, 1937.

J. L. LOCKHEAD

2,085,031

MUZZLE LOADING FIREARM

Filed Oct. 21, 1935

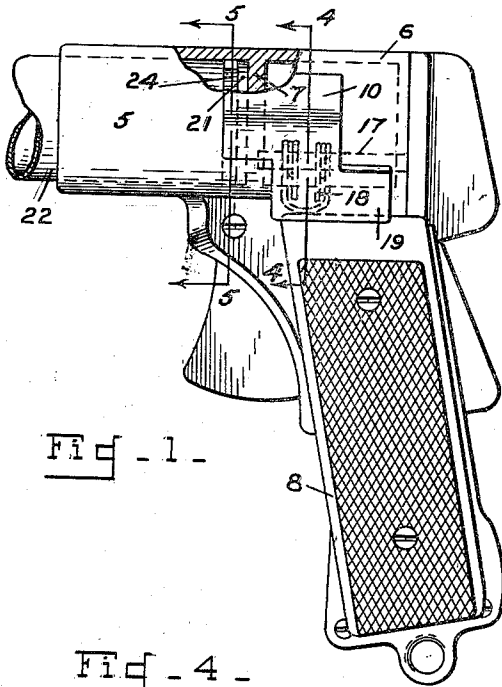

Fig. 1 -

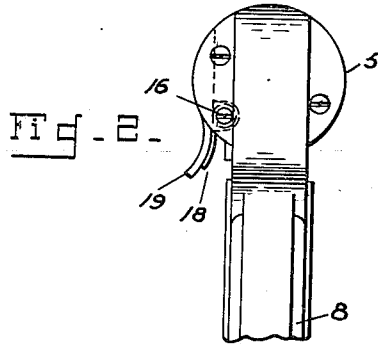

Fig. 2 -

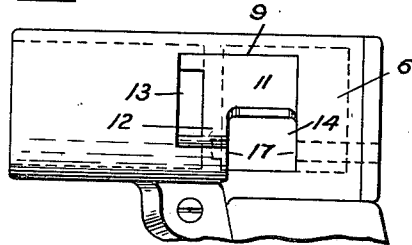

Fig. 4 -

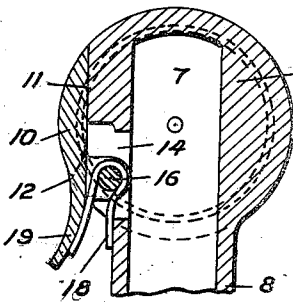

Fig. 5 -

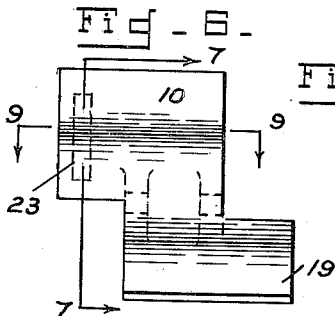

Fig. 6 -

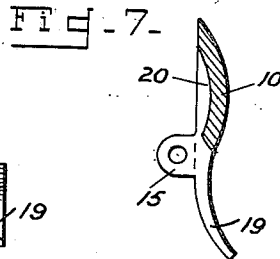

Fig. 7 -

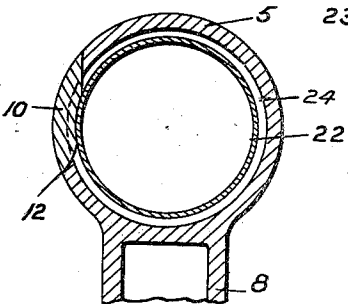

Fig. 8 -

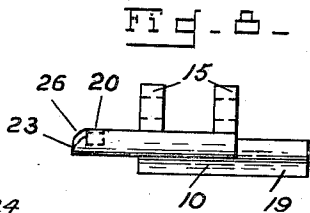

Fig. 9 -

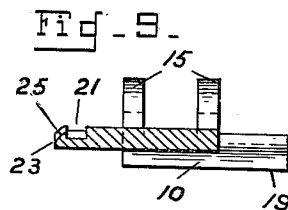

Fig. 10 -

Inventor
John L. Lockhead
By *W. M. Roach*
Attorney

UNITED STATES PATENT OFFICE

2,085,031

MUZZLE LOADING FIREARM

John L. Lockhead, Springfield, Mass.

Application October 21, 1935, Serial No. 45,953

1 Claim. (Cl. 42—1)

(Granted under the act of March 3, 1883, as amended April 30, 1928; 370 O. G. 757)

The invention described herein may be manufactured and used by or for the Government for governmental purposes, without the payment to me of any royalty thereon.

5 This invention relates to a muzzle loading firearm particularly adapted for firing pyrotechnic signals and the like and is an improvement on the firearm shown in Patent No. 1,747,057 of February 11, 1930 and Patent No. 1,970,501 of August 14, 1934.

10 In the latter patent the cartridge is retained in the barrel by a latch that must be hand fitted at assembly to provide perfect contact.

15 The purpose of this invention is to provide an arrangement of latch and frame whereby these elements may be cast and machine finished and still be interchangeable. This is accomplished by establishing an engaging surface which is parallel to a diameter of the barrel and lock case of the frame. The formation of the engaging surface of the frame provides a slot for receiving the latch and it also provides an opening in the barrel for receiving the claw of the latch. The claw of the latch is formed by grooving the forward portion of the latch.

25 To these and other ends, the invention consists in the construction, arrangement and combination of elements described hereinafter and pointed out in the claim forming a part of this specification.

30 A practical embodiment of the invention is illustrated in the accompanying drawing, wherein:

35 Fig. 1 is a view in side elevation with parts in section of the improved firearm and showing a cartridge loaded therein.

Fig. 2 is a view in rear elevation.

Fig. 3 is a view in side elevation of a portion of the frame.

40 Figs. 4 and 5 are sectional views on the respective lines of Fig. 1.

Fig. 6 is a view in elevation of the latch.

Fig. 7 is a sectional view on the line 7—7 of Fig. 6.

45 Fig. 8 is a plan view of the latch, and

Fig. 9 is a sectional view on the line 9—9 of Fig. 6.

50 Referring to the drawing by characters of reference there is shown a pistol frame including a short muzzle loading barrel 5, a lock case 6, a breech plate 7 between the barrel and lock case, and a grip 8.

55 A cut is made in one side of the frame to form a slot 9 (Fig. 3) for receiving a latch 10 and to establish a seating surface 11 for the latch which is parallel to the vertical center line of the frame except for its lower portion which is slightly curved as shown at 12 in Fig. 5. The cut extends through the rear portion of the barrel 5 and provides an aperture 13 in the barrel. The outer

surface of the latch conforms to the contour of the frame and the inner surface conforms to the seating surfaces 11 and 12.

A recess 14 is cut in the side wall of the lock case and is embraced within the length of the slot 9 but extends below the same. A pair of eyes 15—15 on the latch are disposed within the recess 14 and receive a pivot pin 16 which is mounted in spaced longitudinally extending passages 17—17 in the lock case 6. A spring 18 coiled on the pivot pin has one end bearing against the grip 8 and the other end bearing against a downwardly extending finger-piece 19 on the latch.

The forward portion of the latch is provided on its inner side with an arcuate groove 20 adapted to receive the rim 21 of a signal cartridge 22. The provision of the groove establishes a claw 23 which is insertable in the cannellure 24 of the cartridge. The inner face of the claw is curved as at 25 to conform to the cylindrical contour of the cartridge and its front extremity is beveled as at 26.

The outer surface of the latch is flush with the frame when it is held in normal cartridge-engaging position by the spring 18. When the cartridge case is inserted in the barrel the rim strikes the beveled edge 26 of the latch and moves it outwardly until the rim is opposite the groove 20, at which time the claw 23 snaps into the cannellure 24. The cartridge case is now securely held in the loaded position. It is released by acting on the finger-piece of the latch.

By virtue of this construction the frame and latch may be cast and machined to a finish. The parts are interchangeable and will not require special hand fitting at assembly. The upper portion of the latch will have close contact with the seating surface 11 and the lower portion will also have a good fit on the curved seating surface 12 because the latter is close to the axis of rotation of the latch.

I claim:—

60 In a firearm, a frame including a barrel and having a cut forming a slot to establish a seating surface whose major portion is parallel to the vertical center line of the frame and whose lower portion is curved, said cut having sufficient depth to extend through the wall of the barrel and provide an opening therein, a latch fitting in the slot and having a surface corresponding to the seating surface of the slot, means for pivotally mounting the latch in the frame with the axis of rotation close to the curved seating portion, said latch having a cartridge-engaging front portion extending through the opening in the barrel when the latch is seated on the seating surface and a spring normally holding the latch on the seating surface.

JOHN L. LOCKHEAD. 60