



(12) **DEMANDE DE BREVET CANADIEN
CANADIAN PATENT APPLICATION**

(13) **A1**

(86) Date de dépôt PCT/PCT Filing Date: 2016/08/24
(87) Date publication PCT/PCT Publication Date: 2017/03/02
(85) Entrée phase nationale/National Entry: 2018/02/12
(86) N° demande PCT/PCT Application No.: PL 2016/000090
(87) N° publication PCT/PCT Publication No.: 2017/034426
(30) Priorité/Priority: 2015/08/25 (PL P.413664)

(51) Cl.Int./Int.Cl. *F03D 1/04* (2006.01)
(71) Demandeur/Applicant:
STASZOR, ROMAN, PL
(72) Inventeur/Inventor:
STASZOR, ROMAN, PL
(74) Agent: ROBIC

(54) Titre : EOLIENNE A TUNNEL AYANT UN AXE HORIZONTAL DE LA ROTATION DU ROTOR
(54) Title: TUNNEL WIND TURBINE WITH A HORIZONTAL AXIS OF THE ROTOR ROTATION

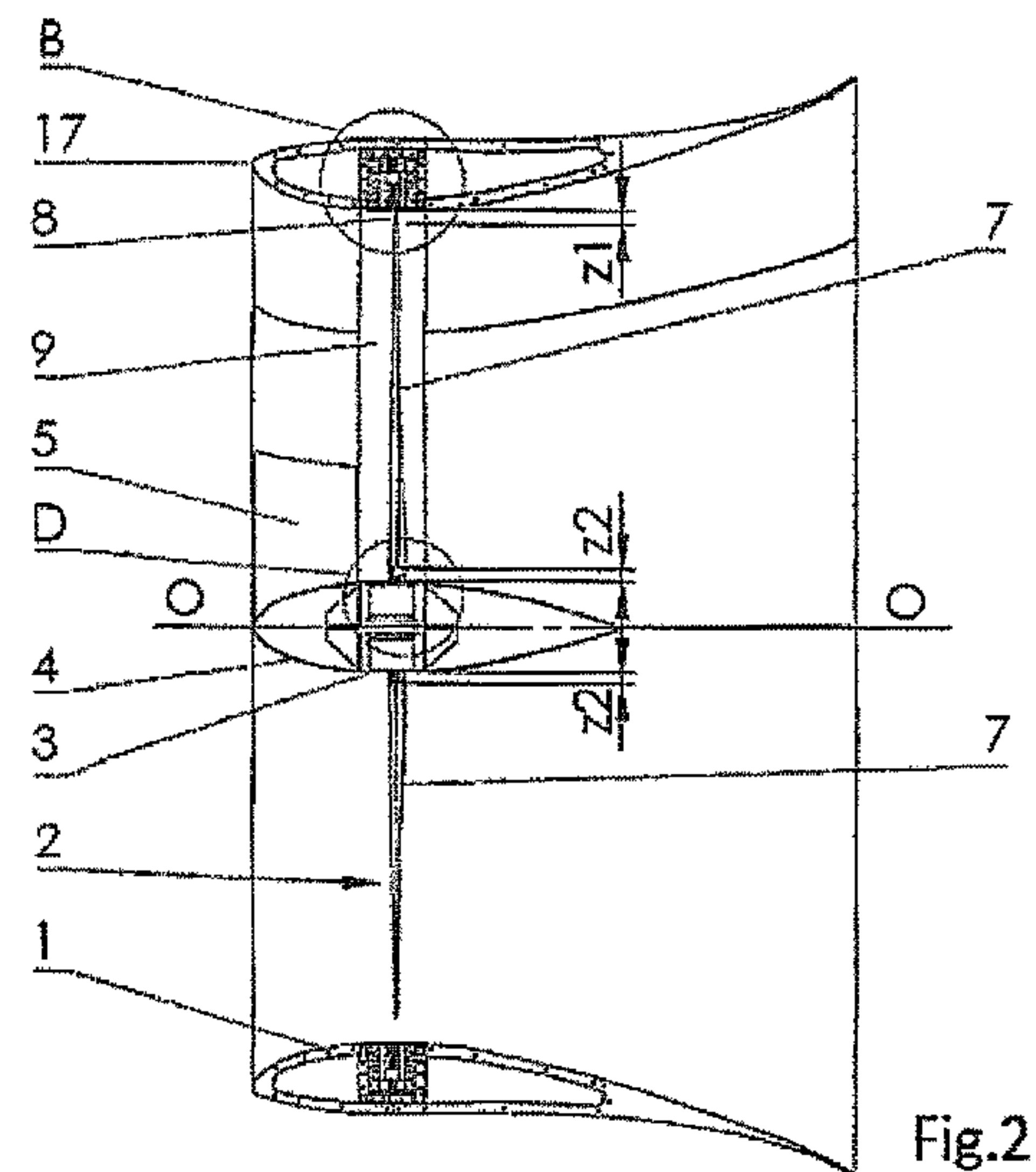
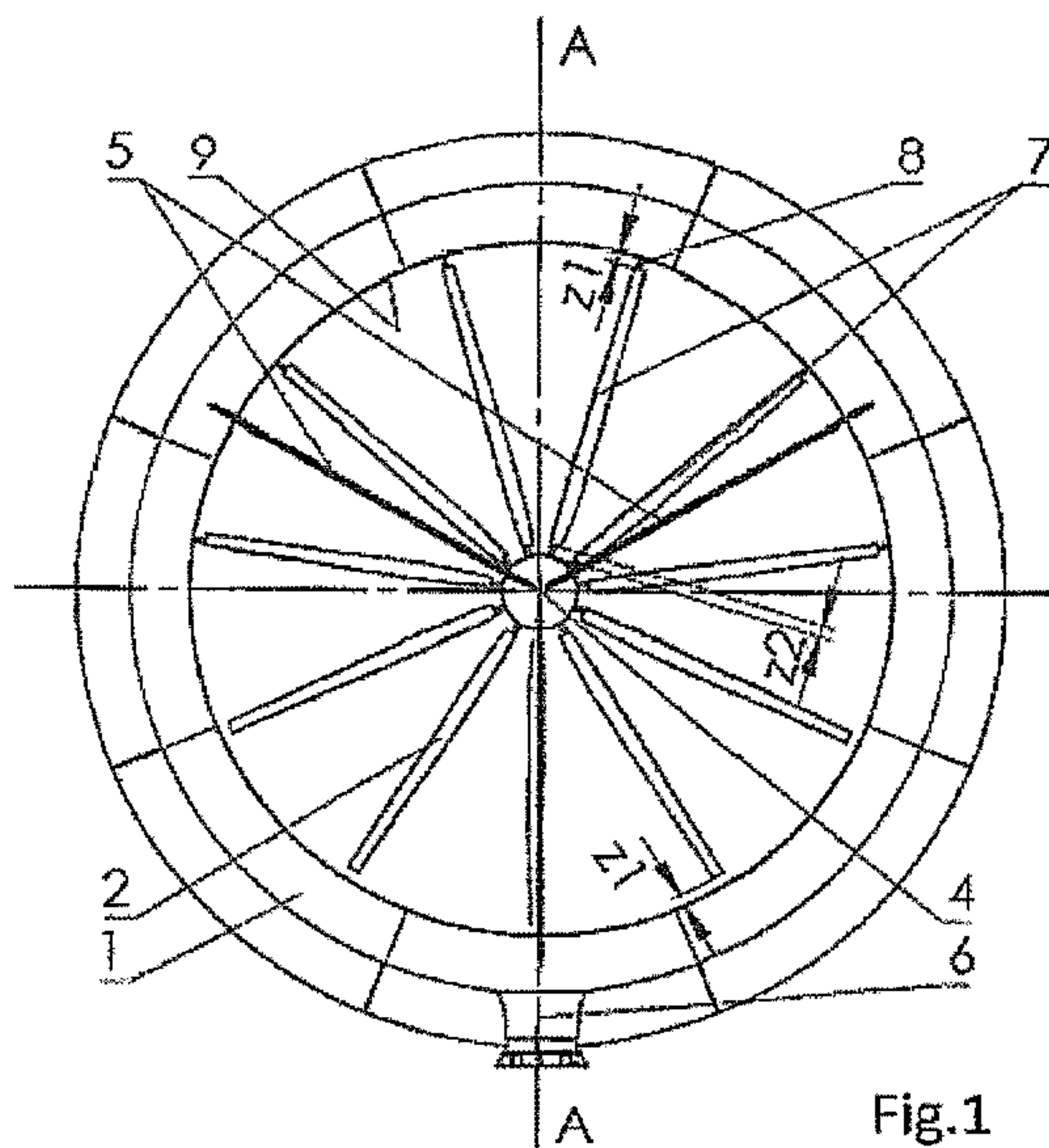

(57) **Abrégé/Abstract:**

The turbine contains a diffuser (1) in the form of a rotational body, the wall of which has the shape of a convex-concave aeronautical profile in the axial section and a rotor (2) with blades (7) rotating in the plane of a throat (R_t) of the diffuser (1) and connected with a hub (3) by lower ends. The lower ends of the blades (7) are set away from the surface of the hub (3) by the dimension of the lower gap (z_2), the dimension being determined by the height of connectors (8) mounted to the lower ends of the blades (7) and to the hub (3), the dimensions of the upper gap (z_1) between the upper ends of the blades (7) and the surface of the throat (R_t) and the lower gap (z_2) have dimensions ranging from 0.5 to 15% of the radius of the throat (R_t), preferably from 3 to 8%. The upper gap (z_1) is determined by the height of the connectors (8) mounted to the upper ends of the blades (7) and to the rotational ring (9) which rotates in the circumferential recess (10) of the diffuser (1) and the inner surface of which has a shape of the throat (R_t). Furthermore, the ratios of the dimensions of the upper gaps (z_1) and the lower gaps (z_2) to the corresponding lengths of chords (c_1 , c_2) on the ends of blade (7) of the profiles have values ranging from 0.20 to 2.5, preferably from 0.6 to 1.2.

(12) INTERNATIONAL APPLICATION PUBLISHED UNDER THE PATENT COOPERATION TREATY (PCT)

(19) World Intellectual Property
Organization
International Bureau(43) International Publication Date
2 March 2017 (02.03.2017)(10) International Publication Number
WO 2017/034426 A1(51) International Patent Classification:
F03D 1/04 (2006.01)(21) International Application Number:
PCT/PL2016/000090(22) International Filing Date:
24 August 2016 (24.08.2016)

(25) Filing Language: English

(26) Publication Language: English

(30) Priority Data:
P.413664 25 August 2015 (25.08.2015) PL

(72) Inventor; and

(71) Applicant : STASZÓR, Roman [PL/PL]; ul. Jedności
Narodowej 8, 97-300 Piotrków Trybunalski (PL).(74) Agent: TABOR-KMIECIK, Katarzyna; ul Mazowiecka
28A/8-9, 30-019 Kraków (PL).(81) Designated States (unless otherwise indicated, for every
kind of national protection available): AE, AG, AL, AM,
AO, AT, AU, AZ, BA, BB, BG, BH, BN, BR, BW, BY,
BZ, CA, CH, CL, CN, CO, CR, CU, CZ, DE, DK, DM,DO, DZ, EC, EE, EG, ES, FI, GB, GD, GE, GH, GM, GT,
HN, HR, HU, ID, IL, IN, IR, IS, JP, KE, KG, KN, KP, KR,
KZ, LA, LC, LK, LR, LS, LU, LY, MA, MD, ME, MG,
MK, MN, MW, MX, MY, MZ, NA, NG, NI, NO, NZ, OM,
PA, PE, PG, PH, PL, PT, QA, RO, RS, RU, RW, SA, SC,
SD, SE, SG, SK, SL, SM, ST, SV, SY, TH, TJ, TM, TN,
TR, TT, TZ, UA, UG, US, UZ, VC, VN, ZA, ZM, ZW.(84) Designated States (unless otherwise indicated, for every
kind of regional protection available): ARIPO (BW, GH,
GM, KE, LR, LS, MW, MZ, NA, RW, SD, SL, ST, SZ,
TZ, UG, ZM, ZW), Eurasian (AM, AZ, BY, KG, KZ, RU,
TJ, TM), European (AL, AT, BE, BG, CH, CY, CZ, DE,
DK, EE, ES, FI, FR, GB, GR, HR, HU, IE, IS, IT, LT, LU,
LV, MC, MK, MT, NL, NO, PL, PT, RO, RS, SE, SI, SK,
SM, TR), OAPI (BF, BJ, CF, CG, CI, CM, GA, GN, GQ,
GW, KM, ML, MR, NE, SN, TD, TG).

Published:

- with international search report (Art. 21(3))
- before the expiration of the time limit for amending the
claims and to be republished in the event of receipt of
amendments (Rule 48.2(h))

(54) Title: TUNNEL WIND TURBINE WITH A HORIZONTAL AXIS OF THE ROTOR ROTATION

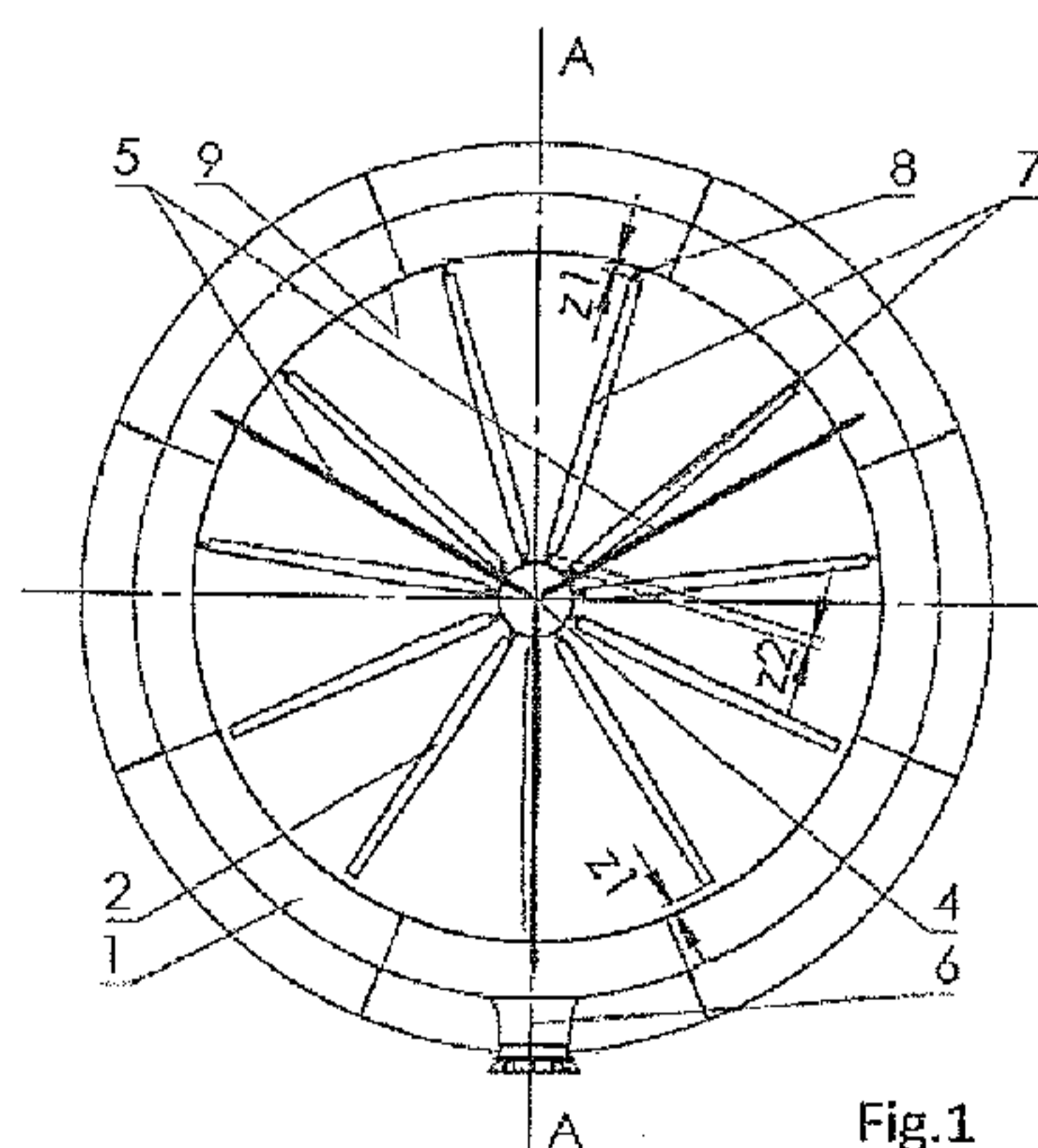

Fig.1

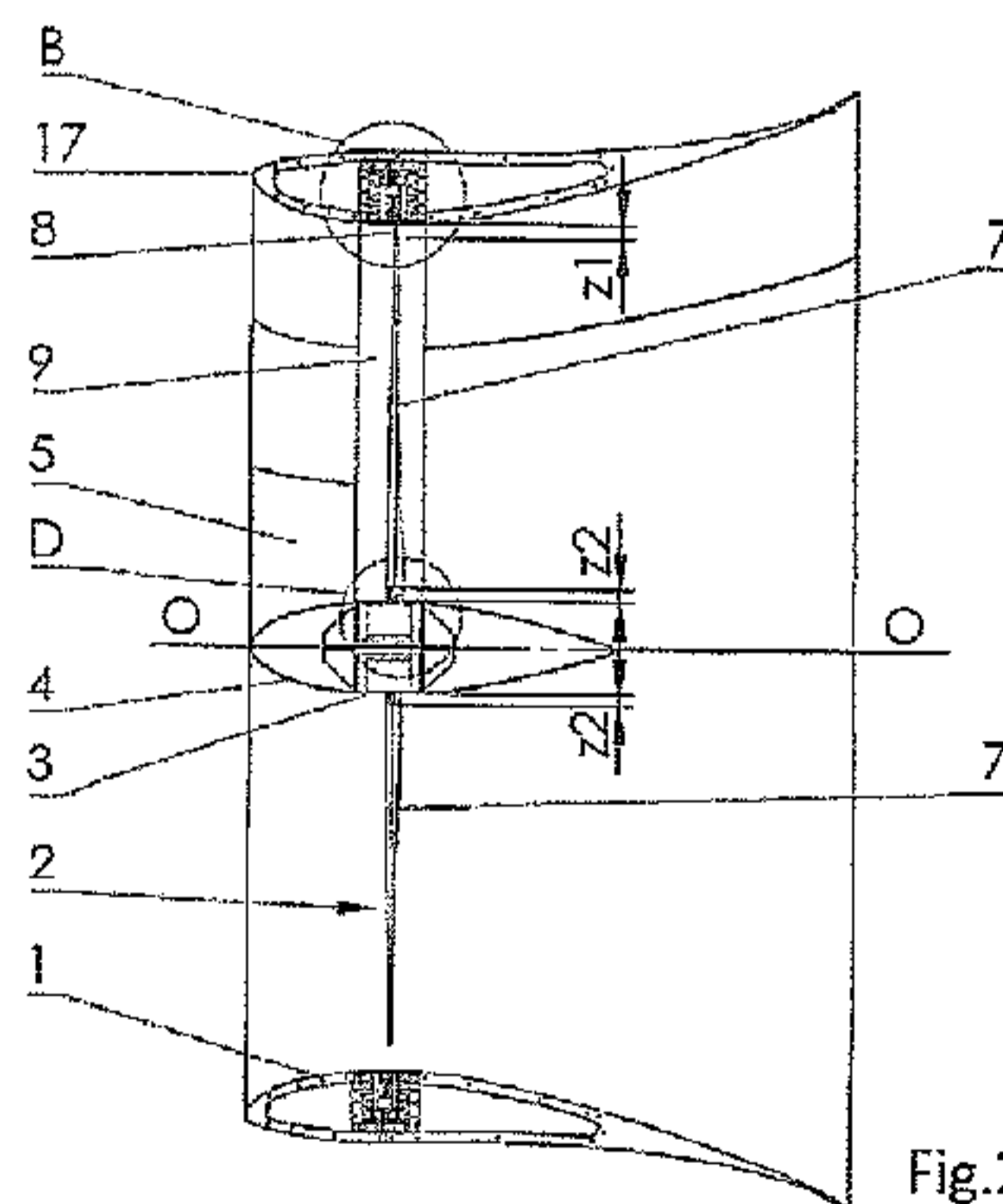

Fig.2

(57) **Abstract:** The turbine contains a diffuser (1) in the form of a rotational body, the wall of which has the shape of a convex-concave aeronautical profile in the axial section and a rotor (2) with blades (7) rotating in the plane of a throat (R_1) of the diffuser (1) and connected with a hub (3) by lower ends. The lower ends of the blades (7) are set away from the surface of the hub (3) by the dimension of the lower gap (z_2), the dimension being determined by the height of connectors (8) mounted to the lower ends of the blades (7) and to the hub (3), the dimensions of the upper gap (z_1) between the upper ends of the blades (7) and the surface of the throat (R_1) and the lower gap (z_2) have dimensions ranging from 0.5 to 15% of the radius of the throat (R_1), preferably from 3 to 8%. The upper gap (z_1) is determined by the height of the connectors (8) mounted to the upper ends of the blades (7) and to the rotational ring (9) which rotates in the circumferential recess (10) of the diffuser (1) and the inner surface of which has a shape of the throat (R_1). Furthermore, the ratios of the dimensions of the upper gaps (z_1) and the lower gaps (z_2) to the corresponding lengths of chords (c_1, c_2) on the ends of blade (7) of the profiles have values ranging from 0.20 to 2.5, preferably from 0.6 to 1.2.

WO 2017/034426 A1

Tunnel wind turbine with a horizontal axis of the rotor rotation

The subject of the invention is a single stage diffuser wind turbine with a horizontal axis of the rotor rotation, converting kinetic energy of air into rotational mechanical energy and then transformed into electric energy in a current generator.

The development of tunnel wind turbines results mainly from the elimination of losses of centrifugal kinetic energy of air and the possibility to recover it through additional increase of the speed of air flowing through a rotor built into the throat of the diffuser. There are many various solutions of single stage diffuser wind turbines with a horizontal axis of the rotor rotation, the design of which is to ensure high power coefficient from the area covered by the rotor [W/m^2]. The condition is to accelerate and increase the volume of the stream of air in the throat, which requires maintaining relatively laminar air flow through the diffuser while keeping the obtuse angle as wide as possible. There are known many wind turbines with solutions employing swirls to support stabilisation of the stream of air flowing through the diffuser and to prevent detachment of the air flow from the wall in the obtuse zone at the outlet of the diffuser as well as behind the nacelle.

Due to the full use of the wind energy in the contemporary solutions of tunnel turbines, there are acceptably used small gaps between the upper ends of blades and the surface of the throat and practically gapless connection with the hub. The selection of the upper gap dimension only takes into account the assembly and installation conditions, the elongation of blades loaded with centrifugal force and the radial "runout" with the permissible wear of the hub bearing. The swirls of air generated in such small gaps - practically not exceeding 0.05% of the throat radius - have negligibly small energy and their impact on the flow of air behind the rotor in the underpressure-divergent part of the diffuser is negligibly small.

There are known solutions of tunnel turbines, presented, among others, in patent descriptions W02009063599, WO2010005289, WO2014134032 and JP2003278635 in which there is a flange offset perpendicularly outwards behind which underpressure and circumferential swirls are formed along the edge of the flange with axes lying in the plane perpendicular to the axis of the diffuser. There is also known a solution presented in the description JP2006152854 with a rotor situated in the plane of the throat of the diffuser, the wall of which has an aeronautical profile in the cross-section. The inner surface of the wall of the diffuser, near the outlet, is perforated with numerous nozzles which are connected through

channels conducted through ribs connecting the diffuser with the nacelle with a suction nozzle situated in the axis of the rear end of the nacelle. The underpressure existing behind the nacelle causes air to be sucked in through the holes of an open end zone of the diffuser, with a preferable result of near-wall layers of flowing air being sucked to the diffuser wall with an air flow stabilisation effect.

Apart from the above mentioned, there is also known a solution of a turbine presented by the patent description US4720640, containing an immobile diffuser in the form of a rotational body, the wall of which has a convex-concave shape with its nose directed towards the inflowing air. There is a rotor with blades situated in the diffuser throat plane, the blades being connected with their lower ends with a hub bearing mounted coaxially with the diffuser. The contour of the hub is consistent with an aerodynamic profile of the nacelle. The upper ends of the blades are connected with a rotational ring situated in a ring recess of the diffuser, the inner surface of the ring forming the diffuser throat zone. The description presents two possible embodiments of the turbine: with a current generator built into a ring recess of the diffuser and with an electric generator built into the nacelle and a rotor of which is driven from the side of the rotor hub.

The technical problem solved by the present invention is an increase of the efficiency of a diffuser wind turbine by intensifying the preferable impact of swirls to reduce the total resistance of flow and to increase the stream of the volume of air flowing through the turbine.

The turbine according to the present invention has, similarly as in the solutions described above, an immobile diffuser in the form of a rotating body, the wall of which has, in its axial section, the shape of a convex-concave aeronautical profile with its nose directed towards the inflowing air and which is supported on the turbine mast by the wind direction bearing set. In the diffuser throat plane there is a bearing mounted blade rotor, the blades of which are connected by their lower ends with the hub bearing mounted coaxially with the diffuser. The hub has a contour consistent with a streamlined profile of the nacelle which is connected by ribs with the diffuser. The essence of the invention consists in that the lower ends of the blades are set away from the hub surface by the dimension of the lower gap determined by the height of connectors fixed to the lower ends of the blades and to the hub. In this case, the dimensions of the upper gap, between the upper ends of the blades and the surface of the throat and the lower gap have dimensions ranging from 0.5 to 15% of the throat radius, preferably from 3 to 8%.

A solution of the turbine is preferable where the upper gap is determined by the height of the connectors fixed to the upper ends of the blades and to a rotational ring which rotates in a circumferential recess of the diffuser and the inner surface of which has the shape of a throat.
65

In both solutions presented above it is preferable if the ratios of the dimensions of the upper and lower gaps to the corresponding lengths of chords of the profiles on the ends of the blade have values ranging from 0.20 to 2.5, preferably from 0.6 to 1.2.

It is preferable in a turbine without a rotational ring if each of the blades is mounted to the hub by two connectors with a round cross section and which are fixed in a radial direction near endings of the profiles of the lower ends of the blades.
70

It is preferable in a turbine with a rotational ring if each of the blades is mounted to the rotational ring and to the hub by two connectors with a round cross section, fixed in a radial direction near endings of the profiles of the upper end and the lower end of the blades.

It is also preferable if the side of the nacelle has the shape being a mirror reflection of a section of the inner surface profile of the diffuser, the ends of the section being determined by points of intersection of the straight line parallel to the diffuser axis and the line conducted through the front point of the diffuser nose advance and the point of intersection of this line and the profile of the open part of the diffuser.
75

In another preferable embodiment, the ratio of the area of the axial projection of the blades on the throat plane to the active area of flow through the throat has a value ranging from 0.02 to 0.30, preferably from 0.10 to 0.15.
80

It is also preferable if the ratio of the inlet hole area to the active area of flow through the throat has a value ranging from 1.0 to 1.6, preferably 1.20 to 1.30 and, in reference to the outlet hole area, it has a value ranging from 0.5 to 0.9 and most preferably from 0.65 to 0.75.
85

The invention achieves optimum effects when specific geometrical relations of the diffuser which determine its obtuse angle are maintained. The ratio of the diffuser length to the diameter of the throat should have a value ranging from 0.3 to 1.1, preferably from 0.6 to 0.8, and in relation to the diameter of the outlet hole, a value ranging from 0.1 to 0.9, preferably from 0.4 to 0.6, whereas, in relation to the diameter of the inlet hole, a value ranging from 0.2 to 1.0, preferably from 0.5 to 0.7.
90

In an embodiment of the turbine with a rotational ring, it is preferable if the circumferential recess is formed by a round support frame of a C-shaped cross section open in the direction of the rotor rotation axis and to which composite coatings determining the

95 aeronautical profile of the diffuser and a lower module of the wind direction bearing set are mounted.

The electrical current generator in the embodiment of the turbine without a rotational ring is a generator built in a nacelle, the rotor of which is driven from the rotor hub while, in a turbine with a rotational ring, the current generator is built inside a support frame, fixed
100 magnets are mounted on the external circumference of the rotational ring and induction coils are fixed to the support frame.

In a high power turbine, made according to the invention, the elements of large overall dimensions: the diffuser, its support frame, coatings of the aeronautical profile, the rotational ring and elements of the current generator are divided into circumferential sections with the
105 maximum dimensions enabling transport in standard containers, the sections being interconnected on the place of operation into the required working shape.

The solution of the turbine according to the invention in the wall layers of the diffuser and the nacelle generates swirl structures having axes essentially parallel to the axis of the diffuser and significant energy while simultaneously minimising the swirl structures having
110 perpendicular axes. The impact of the swirls caused by the invention produces pressure changes preventing the distraction of air jets from the surface of both the diffuser and the nacelle. The phenomena are effective when the indicated sizes of the gaps and dimensional relations are used. The flow resistances are preferably minimised by the circumferential symmetrisation of flow obtained by a mirror-like shape of the diffuser and the nacelle.

115 The invention will be fully comprehensible through a description of exemplary embodiments of the turbines shown on the drawing, the particular figures of which present:

Fig.1 - front view of the turbines from the air inlet side, presenting:

- on the upper half, an embodiment with the rotor blades connected on both ends by
120 connectors with the rotational ring and with the nacelle hub, and,
- on the lower half, an embodiment with the rotor blades connected by connectors only with the hub, in an embodiment without the rotational ring,

Fig.2 - axial section through the A-A line with Fig.1,

Fig.3 - detail B of the drawing in Fig.2,

125 Fig.4 - cross section through the C-C line with Fig.3,

Fig.5 - detail D of the drawing in Fig.2,

Fig.4 - cross section through the E-E line with Fig.5,

Fig.7 - axial section through the diffuser and the nacelle with marking of the characteristic dimensions of the diffuser,

130 Fig.8 - front view of the turbine support frame with a rotational ring,

Fig.9 - detail F of the drawing in Fig.8, in perspective,

Fig.10 - detail G of the drawing in Fig.8, in perspective,

Fig.11 - perspective "exploded" view of elements of the turbine with a rotational ring and a current generator in the diffuser,

135 Fig. 12 - graph of the impact of relative sizes of the upper gap and the lower gap on the mechanical power of the turbine according to the data obtained while testing the exemplary embodiment with a rotational ring,

Fig. 13 - graph of the impact of the ratio of the upper gap and the lower gap size to the corresponding lengths of chords of blade ends on the mechanical power of the turbine, the graph being made for the exemplary embodiment with a rotational ring.

140

The tunnel turbines according to the invention, similarly to the known solutions, have the diffuser 1 and the rotor 2 which is bearing mounted with the hub 3 in the nacelle 4 fixed coaxially by three radial ribs 5 before the throat R_t of the diffuser 1. The diffuser 1 has a form of a rotational body, the wall of which has the shape of a convex-concave aeronautical profile in the axial section. The aeronautical profile of the diffuser 1 is directed with its nose towards the inflowing air. The diffuser 1 in the lower point of the external wall of the side has a seat of the bearing set 6 for the alignment of the turbine with the direction of wind, of a vertical rotation axis and with which the turbine is supported on the mast not visible in the drawing. The rotor 2, with, for example, 11 blades 7, rotates in the plane of the throat R_t of the diffuser 1.

150

Fig.1 presents two basic optional embodiments of the turbines according to the invention, differing by the design of the rotor 1. In the embodiment shown on the upper half of Fig.1, the upper ends of the blades 7 are connected by spacer connectors 8 with the rotational ring 9 situated in the recess 10 of the diffuser and the inner area of which has the shape of the profile of the throat R_t of the diffuser 1. On the other hand, in the embodiment according to the lower half of Fig.1, the upper ends of the blades 7 are free. In both embodiments, the lower ends of the blades 7 are connected by spacer connectors 8 with the hub 3 having a contour consistent with the aerodynamic profile of the nacelle 4. Between the upper ends of the blades 7 and the surface of the throat R_t of the diffuser 1 there exist upper gaps z_1 which, in the embodiment with

155

the rotational ring 9, are determined by the length of the connectors 8. The lower ends of the
 160 blades 7 are set away from the surface of the hub 3 by the dimension of the lower gap z_2 of
 a length of the connectors 8 mounted to the lower ends of the blades 7 and to the hub 3. The
 dimensions of the upper gap z_1 and the lower gap z_2 can be equal or different but their values
 should always range from 0.5 to 15% of the radius of the throat R_t . For a prototype embodiment,
 this relation amounts to 3.2% with the typical dimensions of the turbine:

165 upper gap z_1 , lower gap z_2 $z_1 = z_2 = 50$ mm
 length of the chord of the upper end of the blade $c_1 = 50$ mm
 length of the chord of the lower end of the blade $c_2 = 66$ mm
 diffuser throat radius $R_t = 1530$ mm
 inlet hole radius $R_i = 1700$ mm
 170 outlet hole radius $R_o = 2026$ mm
 nacelle radius $R_h = 165$ mm
 diffuser length $L_d = 2170$ mm
 nacelle length $L_h = 1360$ mm
 surface of axial projection of 11 blades $\times 25240$ mm² = 277641 mm²

175 The ratios of the dimensions of the upper gaps z_1 and the lower gaps z_2 to the
 corresponding lengths 7 of the chords c_1 and c_2 on the ends of the blade 7 of the profiles are
 also essential for the efficiency of the structure of swirls in the turbine according to the
 invention. Their values should range from 0.20 to 2.5 and in the present exemplary
 embodiment, where $z_1 = z_2$, they amount to 7 and 1.0, respectively. In both embodiments, the
 180 blades 7 of the rotor 2 are fixed to the hub 3 through two connectors 8 of a round cross section
 which are fixed with their axes in a radial direction and near the endings of profiles of lower
 ends of the blades 7. In the embodiment with the rotational ring 9, the upper ends of the blades
 7 are also connected by the same two stud connectors 8 to the rotational ring 9. The
 circumferential symmetrisation of flow through the diffuser 1 is also important for the
 185 invention. It has been achieved as a result of shaping the nacelle 4 according to a mirror
 reflection of a section of the inner surface profile of the diffuser 1, the ends of the section being
 determined by the points of intersection of the straight line l_i parallel to the diffuser axis O-O
 and the line conducted through the front point of advance of the nose 17 of the diffuser and the
 point l_h of the inner surface of the open part of the diffuser. The high efficiency of the impacts of
 190 the initiated system of swirls is achieved while maintaining proper dimensional relations which

in the examined turbine amount to:

- the ratio of the axial projection of the blades 7 onto the plane of the throat R_t to the active area of flow through the throat R_t with the nacelle choke taken into account has a value of 0.12,
- the ratio of the area of the inlet hole R_i to the active area of flow through the throat R_t has a value of 1.22,
- the ratio of the area of the inlet hole R_i to the area of the outlet hole R_o has a value of 0.7,
- the ratio of the length L_d of the diffuser 1 to the diameter of the throat R_t has a value of 0.7,
- the ratio of the length L_d of the diffuser 1 to the diameter of the outlet hole R_o has a value of 0.53, and
- the ratio of the length L_d of the diffuser 1 to the diameter of the inlet hole R_i has a value of 0.64. The obtuse angle 9° results from the dimensions of the tested diffuser 1 as being contained between the aeronautical profile chord and the diffuser axis O-O.

Furthermore, the circumferential recess 10 in the diffuser 1 for the rotational ring 9 is formed by a round support frame 11 of a C-shaped cross section open in the direction of the diffuser axis O-O and to which are mounted composite coatings, the front one 12 and the rear one 13, determining the aeronautical profile of the diffuser 1 and the lower module 14 of the bearing set 6 of the wind direction. In the embodiments of the turbine without the rotational ring 9 but also with the rotational ring 9, the current generator may be an electric generator 15 built into the nacelle 4 with the rotor driven from the hub 3 of the rotor 2. On the other hand, in the embodiment with the rotational ring 9, the current generator 16 is preferably built in the support frame 11, with fixed magnets mounted on the outer circumference of the rotational ring 9 and with the induction coils fixed to the support frame 11. An embodiment of the turbine with the current generator 16 in the diffuser 1 and the electric generator 15 in the nacelle 4 is also possible.

Due to the significant dimensions of the high power turbine and the resultant transport problems, the diffuser 1, its support frame 11, coatings 12, 13, 14 of an aeronautical profile, the rotational ring 9 and elements of the current generator 16 are divided into circumferential sections with maximum dimensions enabling transport in a standard container. In the operation location, they are assembled by being interconnected by means of fasteners 18 into the required working shape of the turbine.

The prototype turbine in the embodiment with the rotational ring 9 was tested in an aerodynamic tunnel. With the speed of wind of 5 m/s, the turbine according to the described

embodiment of the invention showed a significant increase of the mechanical power P_Q in relation to the power of the turbine P_b having the same diffuser and rotor without the lower gap $z_2 = 0$ and with a small upper gap $z_1 = 6$ mm, constituting 0.39 % of the radius of the throat $R_t = 1530$ mm. The chart in Fig. 12 shows the increase of power. The results of the test of the impact of the ratio of dimensions of the upper gap z_1 and the lower gap z_2 to the corresponding lengths of the chords c_1 and c_2 of the ends of the blade on the increase of mechanical power are shown on the chart in Fig. 13. Both charts confirm an increase of power of the turbine with features of the invention which initiate swirls with an effect of much more stabilised and reduced air flow resistance.

To a designer who is an expert in this field, a solution of a turbine containing essential features of the present invention is obvious - that is, the dimensionally specified upper gaps z_1 and lower gaps z_2 generating a preferable system of swirls - the design of the turbine being complemented with a mechanism of change of the advance angle of the blades 7, the mechanism being built into the nacelle.

PATENT CLAIMS

1. A tunnel wind turbine with a horizontal axis of the rotor rotation, including:
 - a diffuser (1) in the form of a rotating body, the wall of which has, in its axial section, the shape of a convex-concave aeronautical profile with a nose (17) directed towards inflowing air and which is supported by a wind direction bearing set (6) of a vertical rotation axis on the turbine mast, and
 - a rotor (2) with blades (7) rotating in the plane of a throat (R_t) of the diffuser (1) and lower ends are connected with a hub (3) bearing mounted coaxially with the diffuser (1) and having a contour consistent with an aerodynamic profile of a nacelle (4) which is connected by ribs (5) with the diffuser (1), characterised in that the lower ends of the blades (7) are set away from the surface of the hub (3) by the dimension of the lower gap (z_2), the dimension being determined by the height of the connectors (8) mounted to the lower ends of the blades (7) and to the hub (3), the dimensions of the upper gap (z_1) between the upper ends of the blades (7) and the surface of the throat (R_t) and the lower gap (z_2) have dimensions ranging from 0.5 to 15% of the radius of the throat (R_t), preferably from 3 to 8%.
2. The turbine according to claim 1 characterised in that the upper gap (z_1) is determined by the height of the connectors (8) fixed to the upper ends of the blades (7) and to the rotational ring (9) which rotates in a circumferential recess (10) of the diffuser (1) and the inner surface of which has a shape of the throat (R_t).
3. The turbine according to claim 1 or 2, characterised in that the ratios of the dimensions of the upper gaps (z_1) and the lower gaps (z_2) to the corresponding lengths of chords (c_1 , c_2) on the ends of blades (7) of the profiles have values ranging from 0.20 to 2.5, preferably from 0.6 to 1.2.
4. The turbine according to claim 1, characterised in that each of the blades (7) is mounted to the hub (3) by two connectors (8) having a round cross section and which are fixed in a radial direction near endings of the profiles of the lower ends of the blades (7).
5. The turbine according to claim 2, characterised in that each of the blades (7) is mounted to the rotational ring (9) and to the hub (3) by two connectors (8) having a round cross section (d), fixed in a radial direction near the endings of the profiles of the upper end and the lower end of the blades (7).

6. The turbine according to claim 1 or 2, characterised in that the side wall of the nacelle (4) has a shape being a mirror reflection of a section of the inner surface profile of the diffuser (1), the ends of the section being determined by points of intersection of the straight line (1_i) parallel to the diffuser axis (O-O) and the one conducted through the front point of the advance of the nose (17) of the diffuser (1) and the point (1_h) of the inner surface in the open part of the diffuser (1).
35
7. The turbine according to claim 1 or 2, characterised in that the ratio of the area of the axial projection of all blades (7) on the plane of the throat (R_t) to the active area of flow through the throat (R_t) has a value ranging from 0.02 to 0.30, preferably from 0.10 to 0.15.
- 40 8. Turbine according to claim 1 or 2, characterised in that the ratio of the area of the inlet hole (R_i) to the active area of flow through the throat (R_t) has a value ranging from 1.0 to 1,6, preferably from 1.20 to 1.30.
9. Turbine according to claim 1 or 2, characterised in that the ratio of the area of the inlet hole (R_i) to the area of the outlet hole (R_o) has a value ranging from 0.5 to 0.9, preferably from
45 0.65 to 0.75.
10. Turbine according to claim 1 or 2, characterised in that the ratio of the length (L_d) of the diffuser (1) to the diameter of the throat (R_t) has a value ranging from 0.3 to 1.1, preferably from 0.6 to 0.8.
11. Turbine according to claim 1 or 2, characterised in that the ratio of the length (L_d) of the
50 diffuser (1) to the diameter of the outlet hole (R_o) has a value ranging from 0.1 to 0.9, preferably from 0.4 to 0.6 whereas the length (L_d) of the diffuser (1) in relation to the diameter of the inlet hole (R_i) has a value ranging from 0.2 to 1.0, preferably from 0.5 to 0.7.
12. The turbine according to claim 2, characterised in that the circumferential recess (10) in the
55 diffuser (1) is formed by a round support frame (11) of a C-shaped cross section open in the direction of the diffuser (1) axis and to which there are mounted composite coatings (12, 13) determining the aeronautical profile of the diffuser (1) and the lower module (14) of the bearing set (6) of the wind direction.
13. The turbine according to claim 1 or 2, characterised in that it has an electric generator (15)
60 built into the nacelle (4) and the rotor of which is driven from the hub (3) of the rotor (2).
14. The turbine according to claim 12, characterised in that there is a current generator (16) built within the support frame (11), with fixed magnets mounted on the outer

circumference of the rotational ring (9) and with induction coils fixed to the support frame (11).

- 65 15. The turbine according to claim 1 or 2 or 14, characterised in that the diffuser (1), its support frame (11), coatings (12,13) of the aeronautical profile, the rotational ring (9) and elements of the current generator (16) are divided into circumferential sections with the maximum dimensions enabling transport in standard containers, the sections being assembled by being interconnected with fasteners (18) into the required working shape of the turbine.

LIST OF FIGURE MARKINGS

1. diffuser
2. rotor
3. hub
4. nacelle
5. rib
6. bearing set
7. blade
8. connector
9. revolving ring
10. recess
11. support frame
12. front coating of profile
13. rear coating of profile
14. lower module with bearing set
15. electric generator
16. current generator
17. aeronautical profile nose
18. fastener

- z1 upper gap
z2 lower gap
c1 length of the chord of the upper end of the blade
c2 length of the chord of the lower end the blade
O-O diffuser axis
Rt diffuser throat radius
Ri inlet hole radius
Rh nacelle hub radius
Ro outlet hole radius
L_d diffuser length
L_h nacelle length

- l_i straight line parallel to the diffuser axis, conducted through the front point of the noseadvance
- l_h point of intersection of the straight line l_j and the inner surface of the diffuser profile
- P_o mechanical power of the turbine according to the exemplary embodiment of the invention
- P_b mechanical power of the turbine with the same diffuser with $z1 = 6$ mm and $z2 = 0$ mm

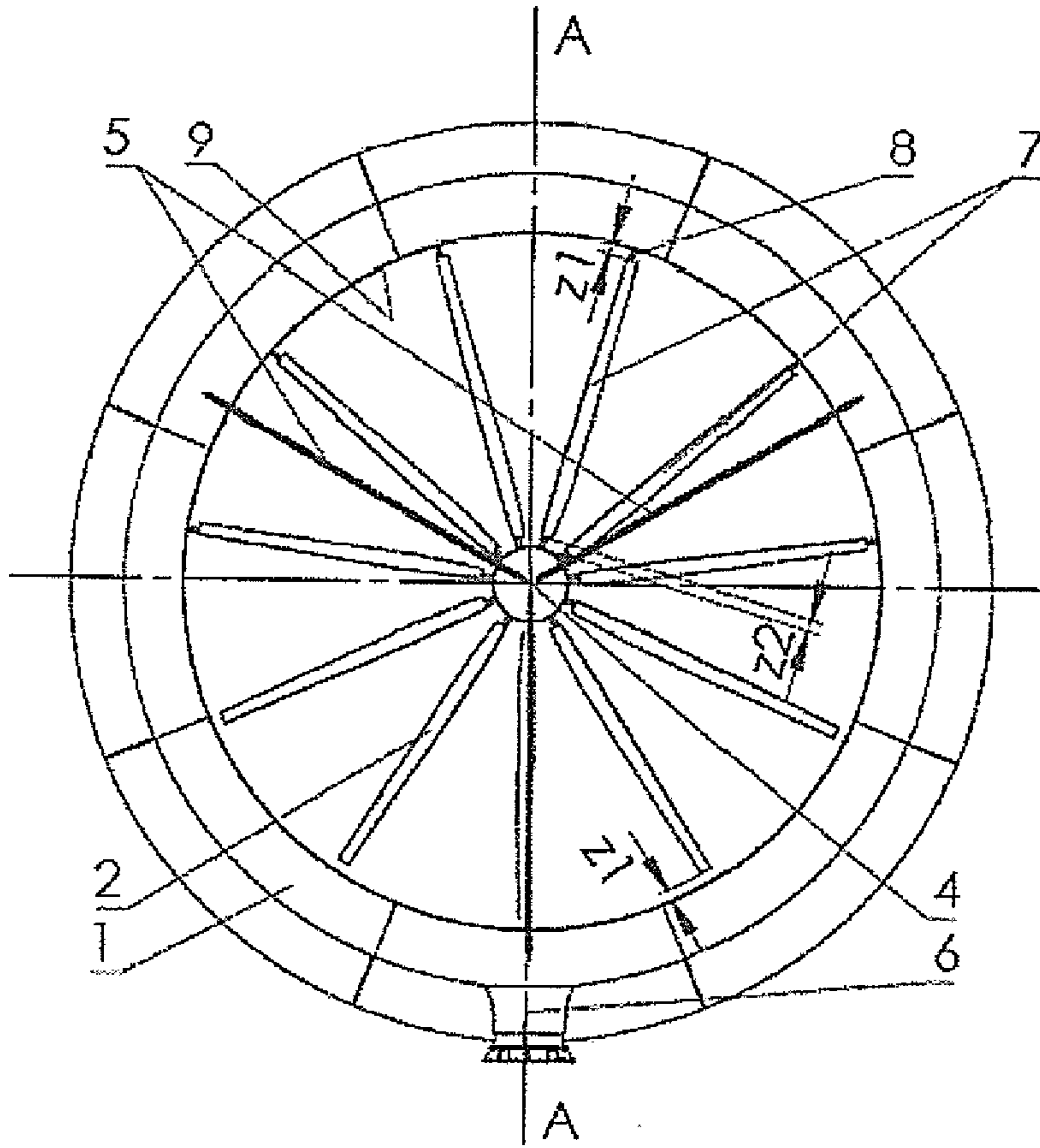

Fig.1

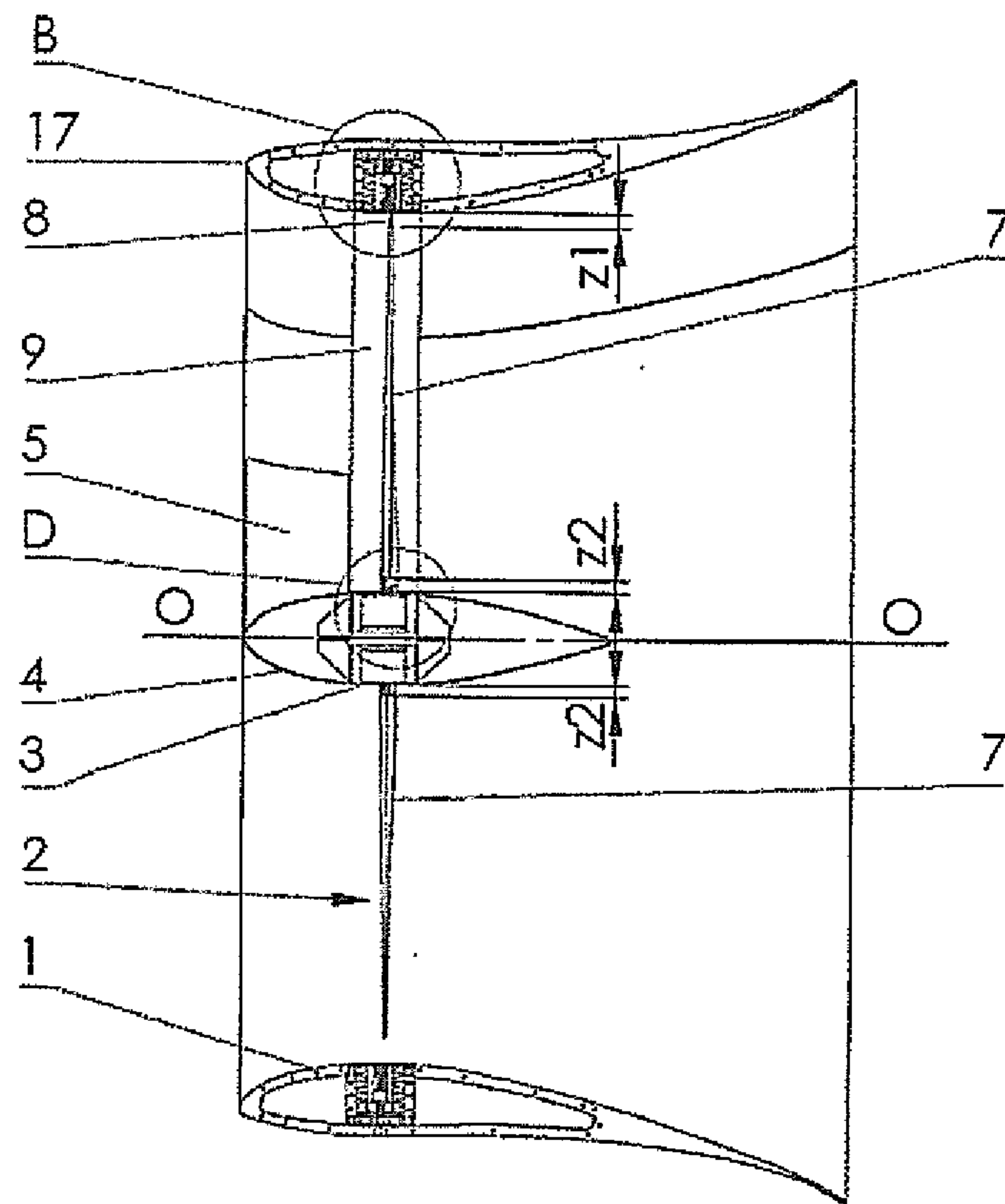

Fig.2

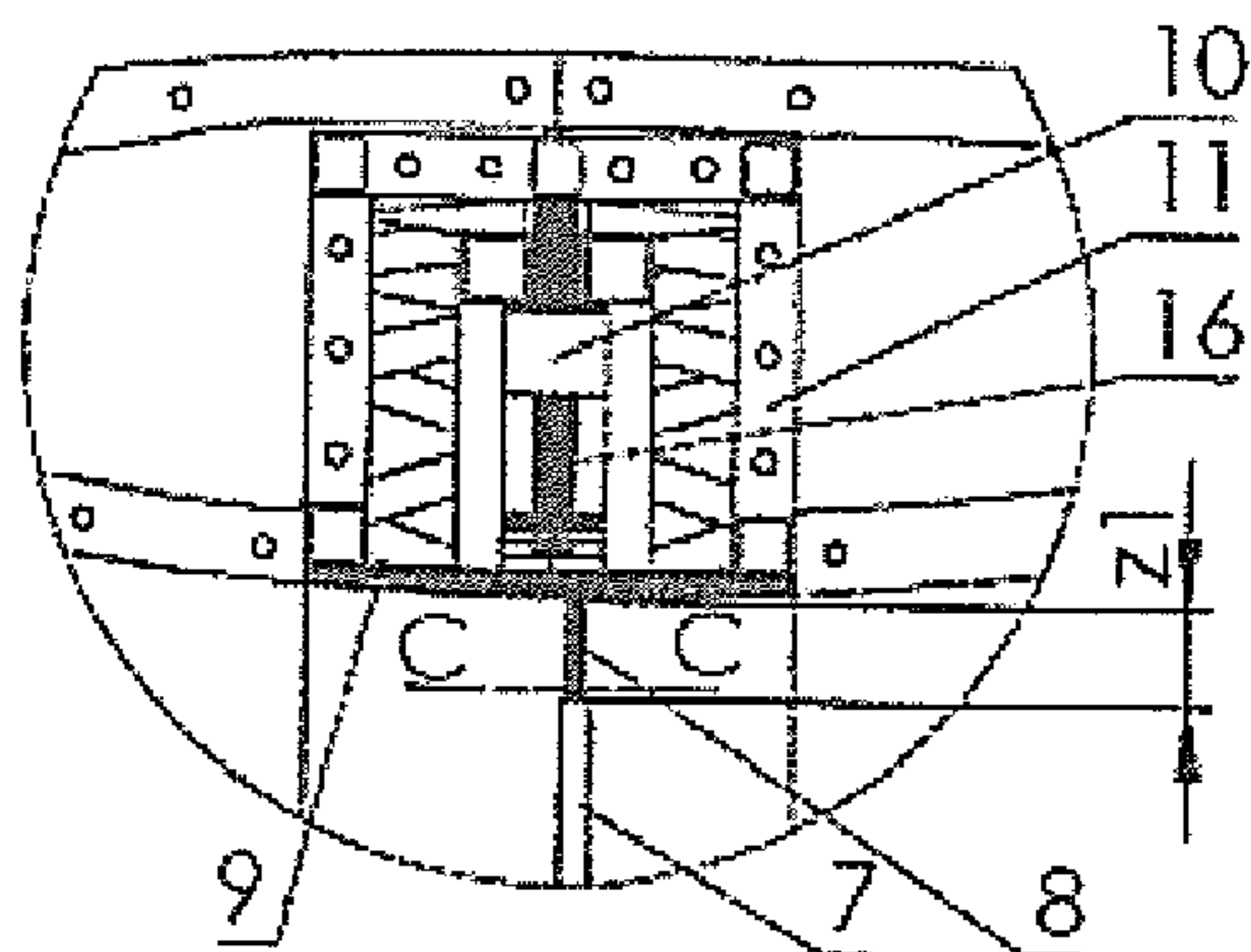

Fig.3

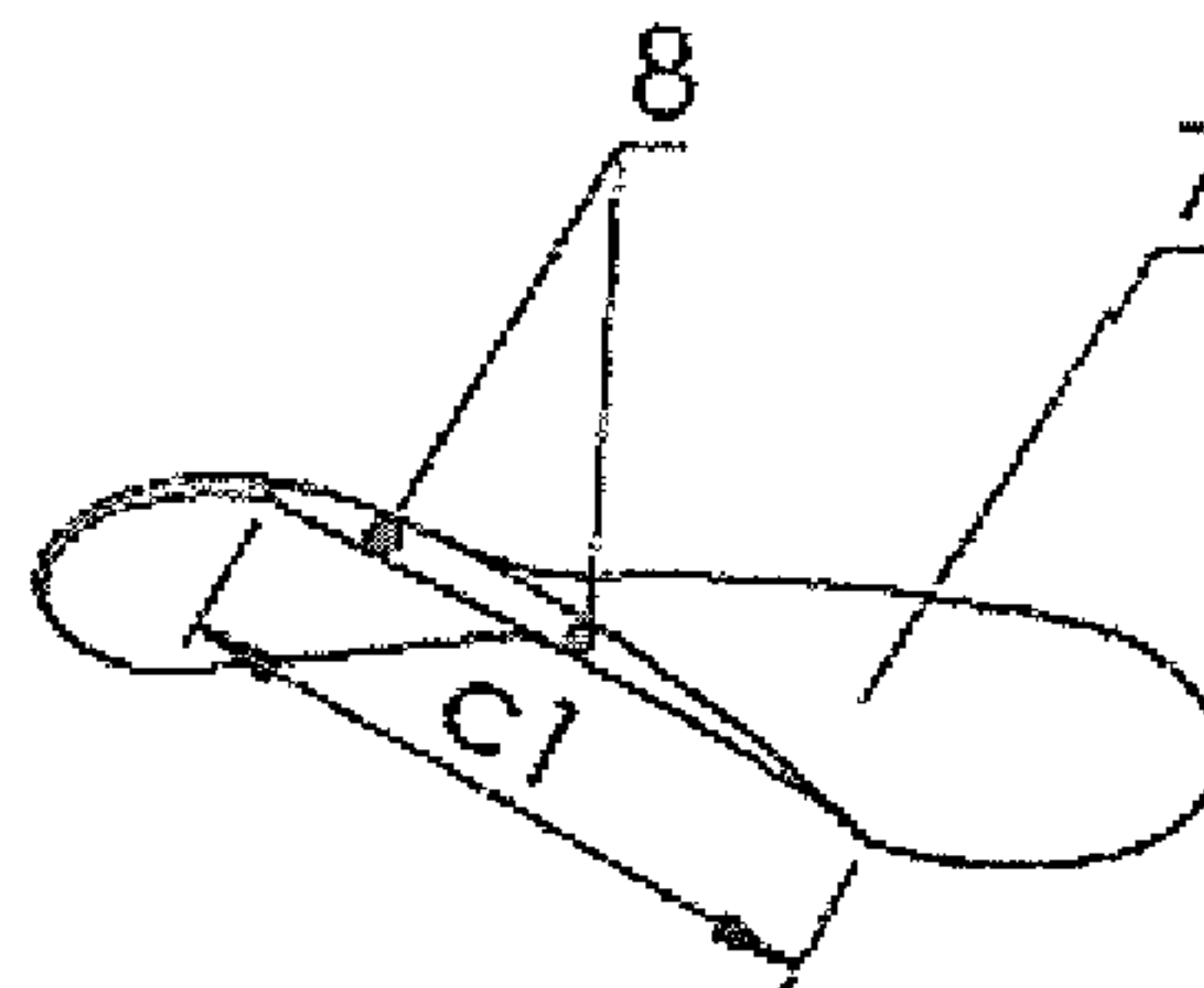

Fig.4

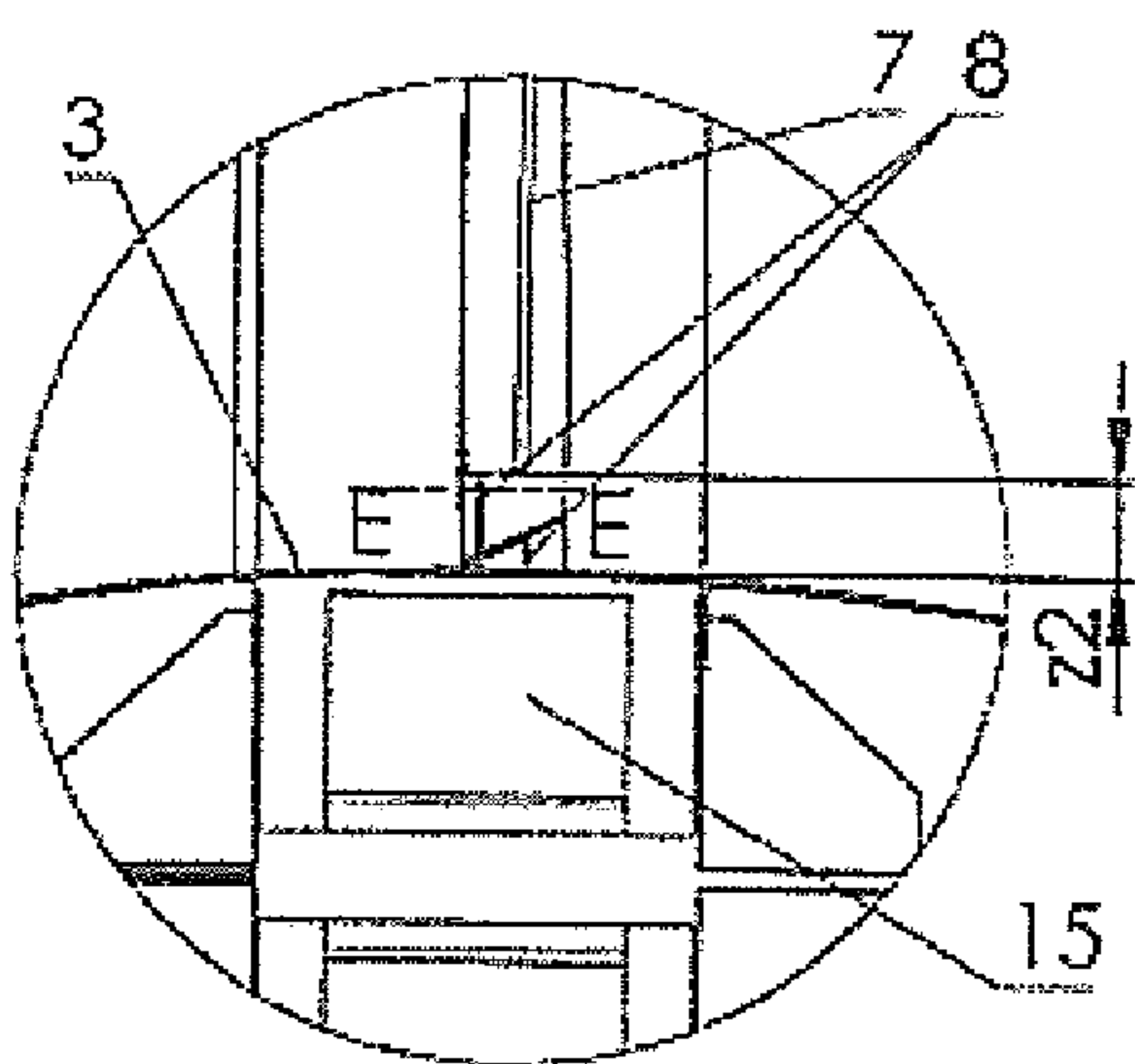

Fig.5

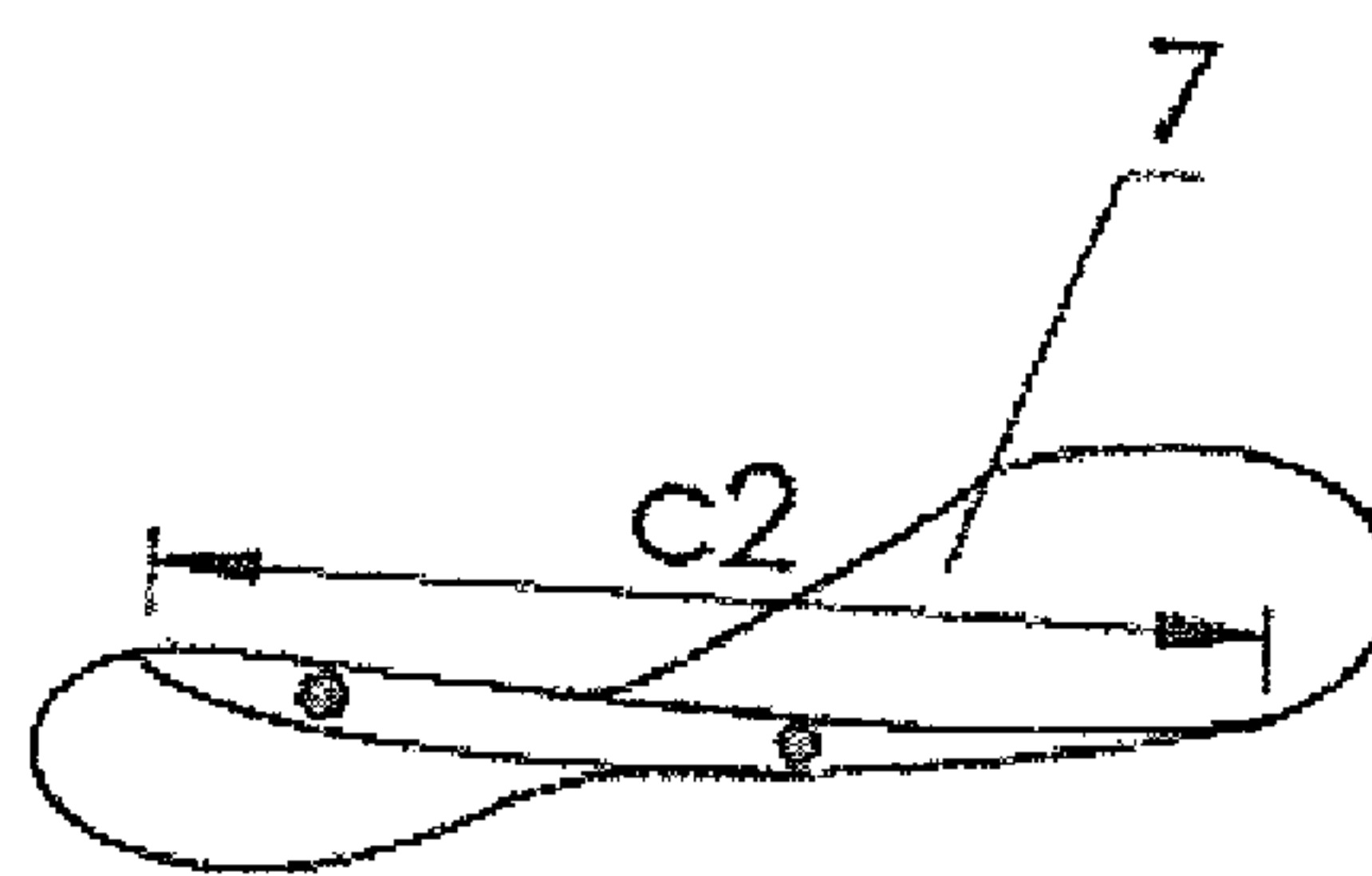

Fig.6

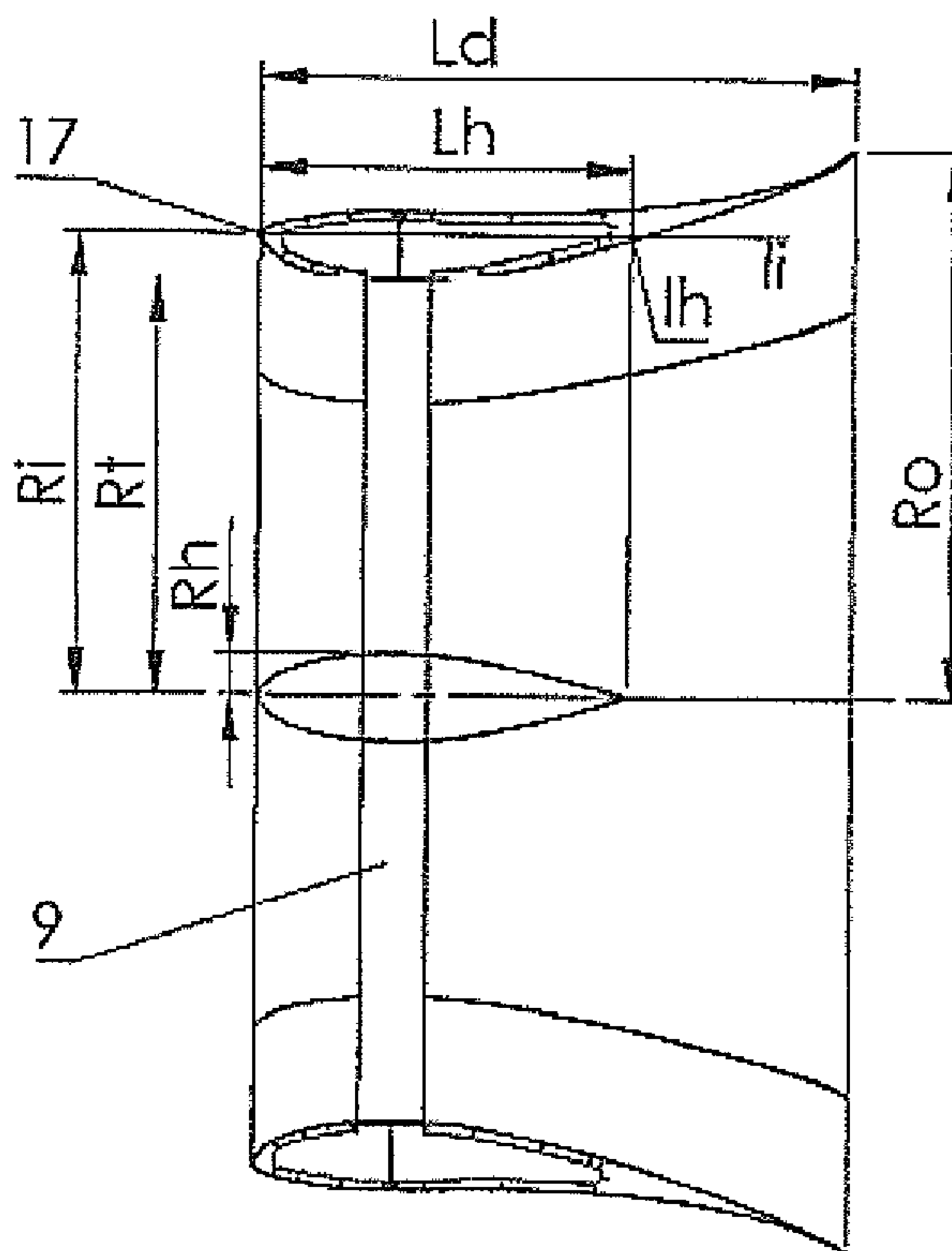

Fig.7

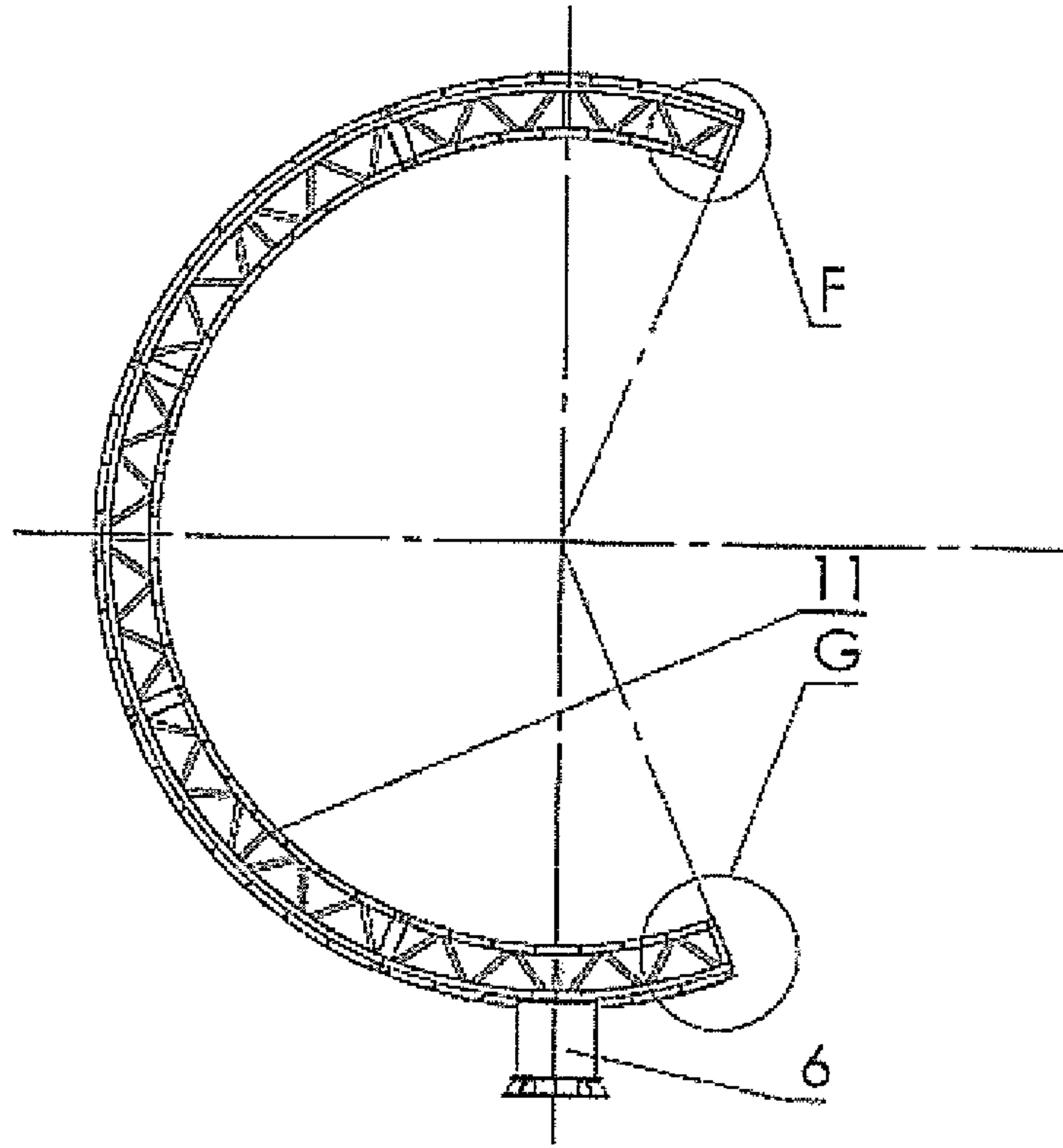

Fig.8

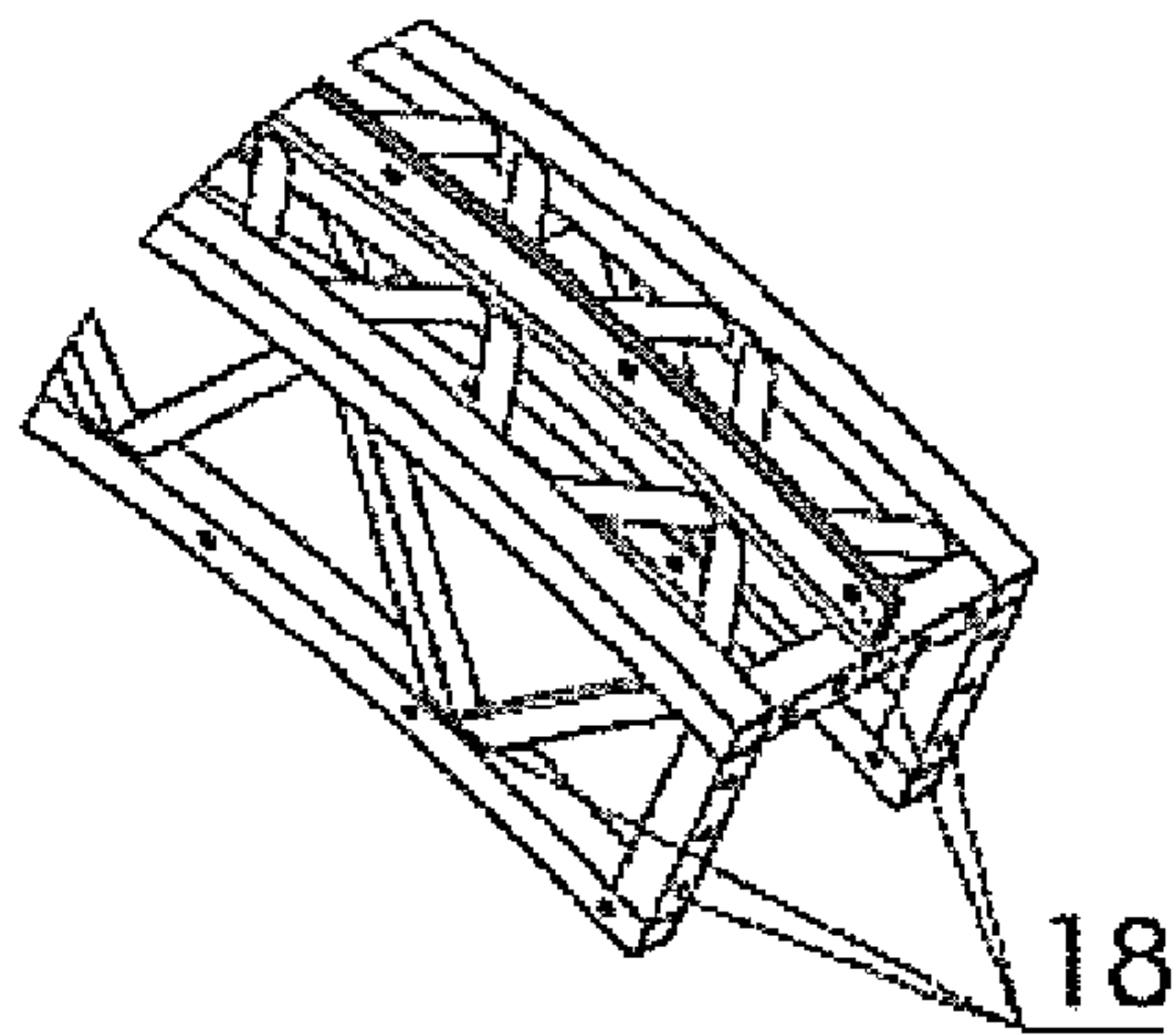

Fig.9

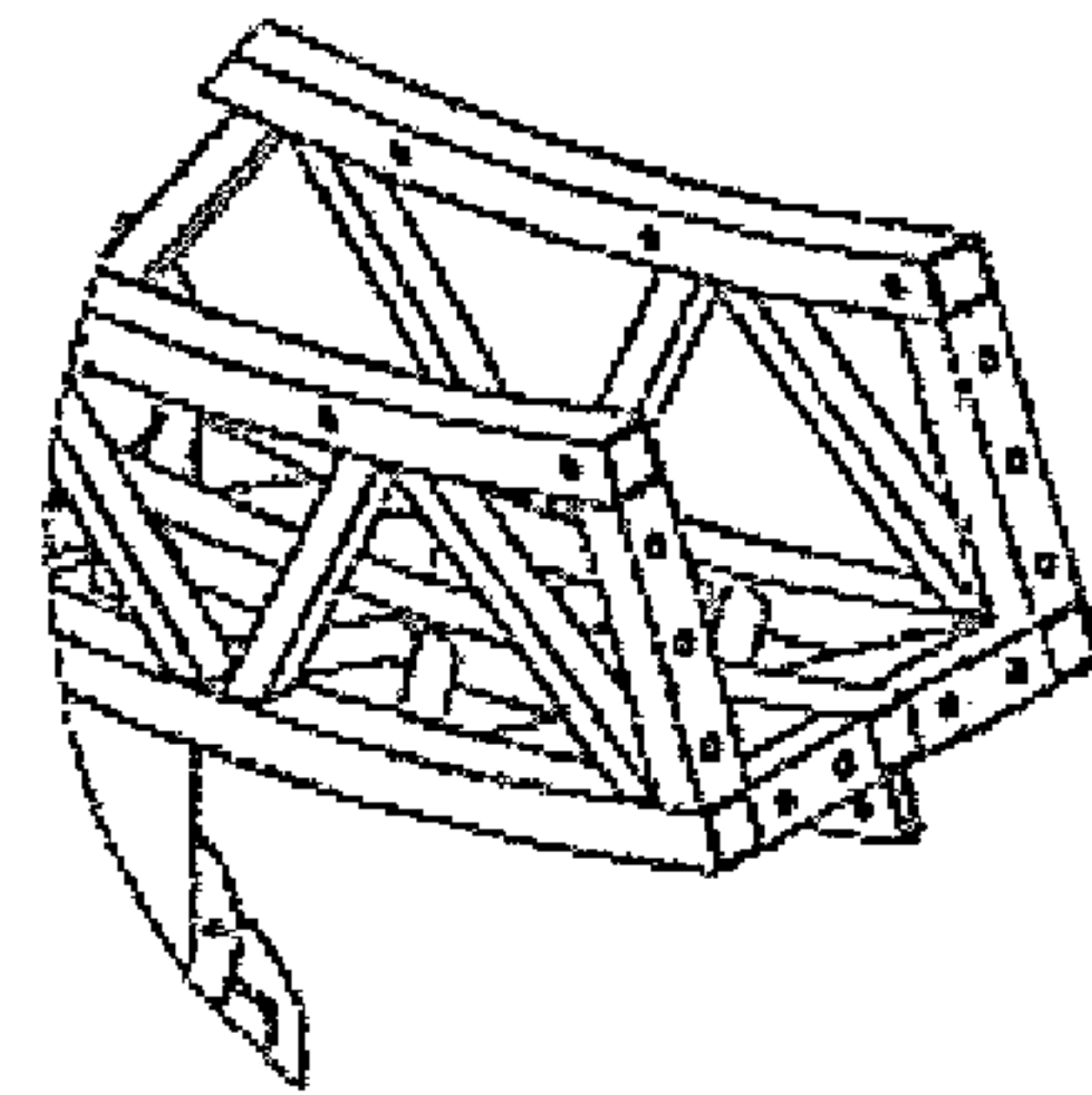

Fig.10

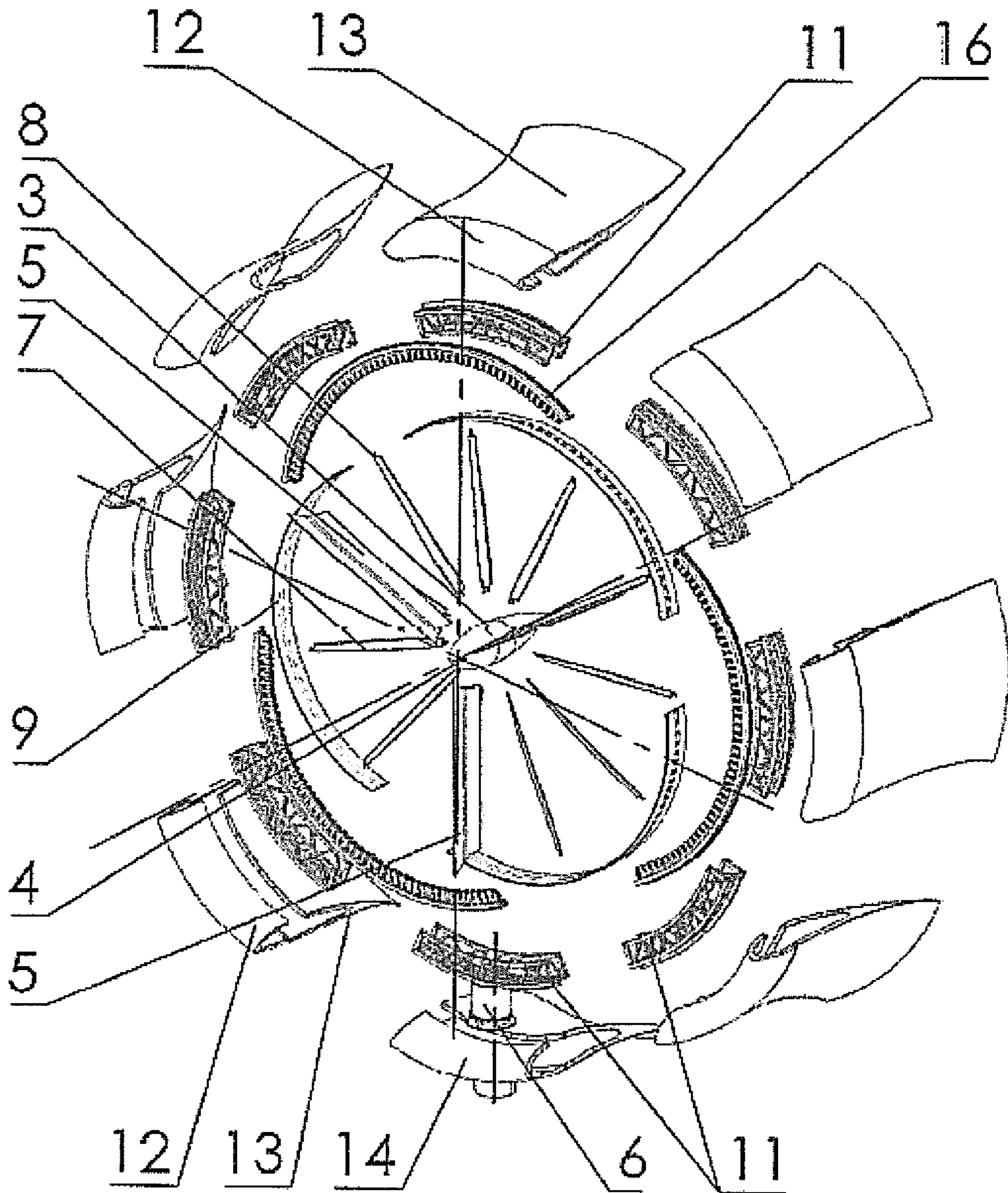

Fig.11

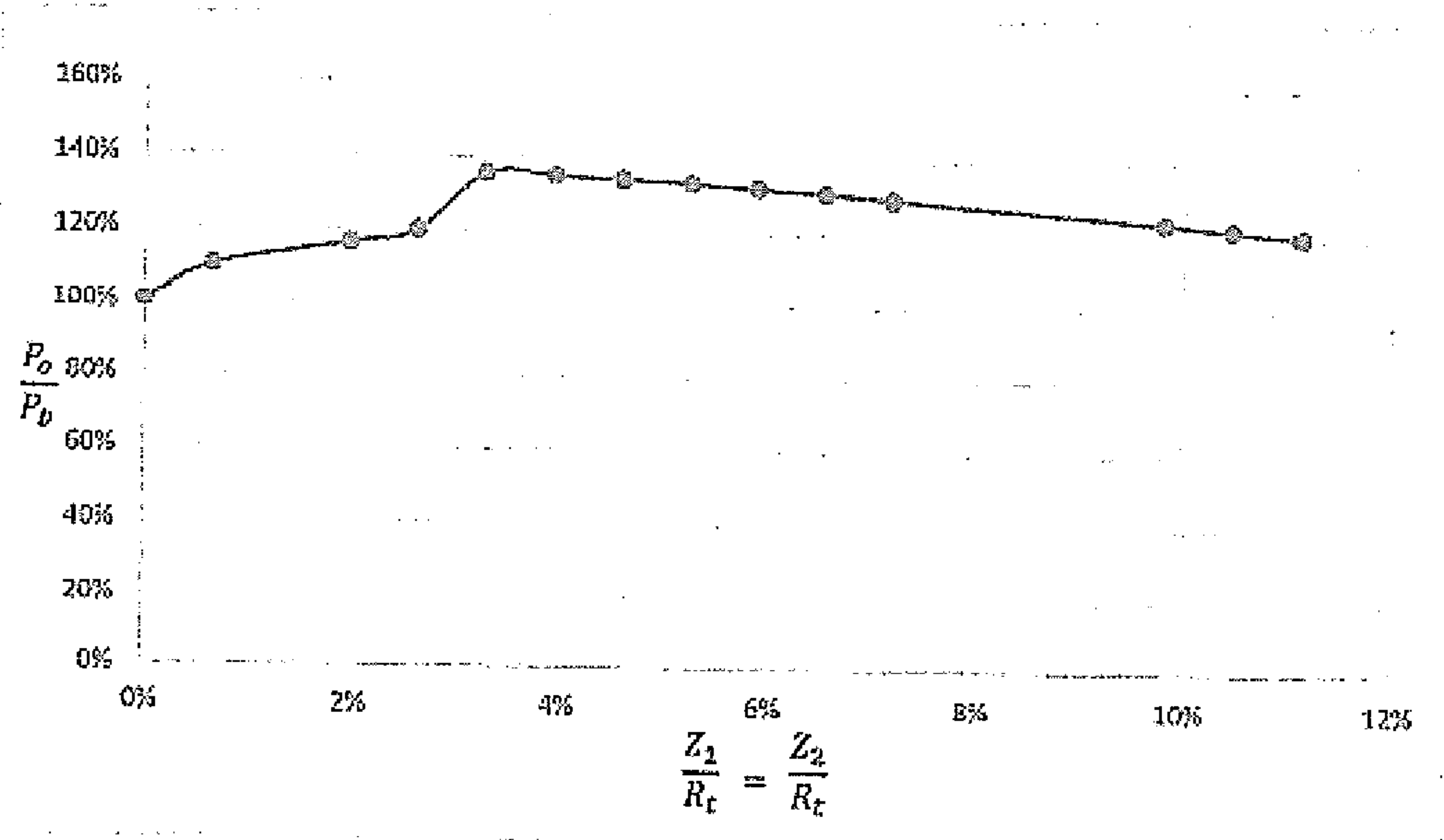

Fig.12

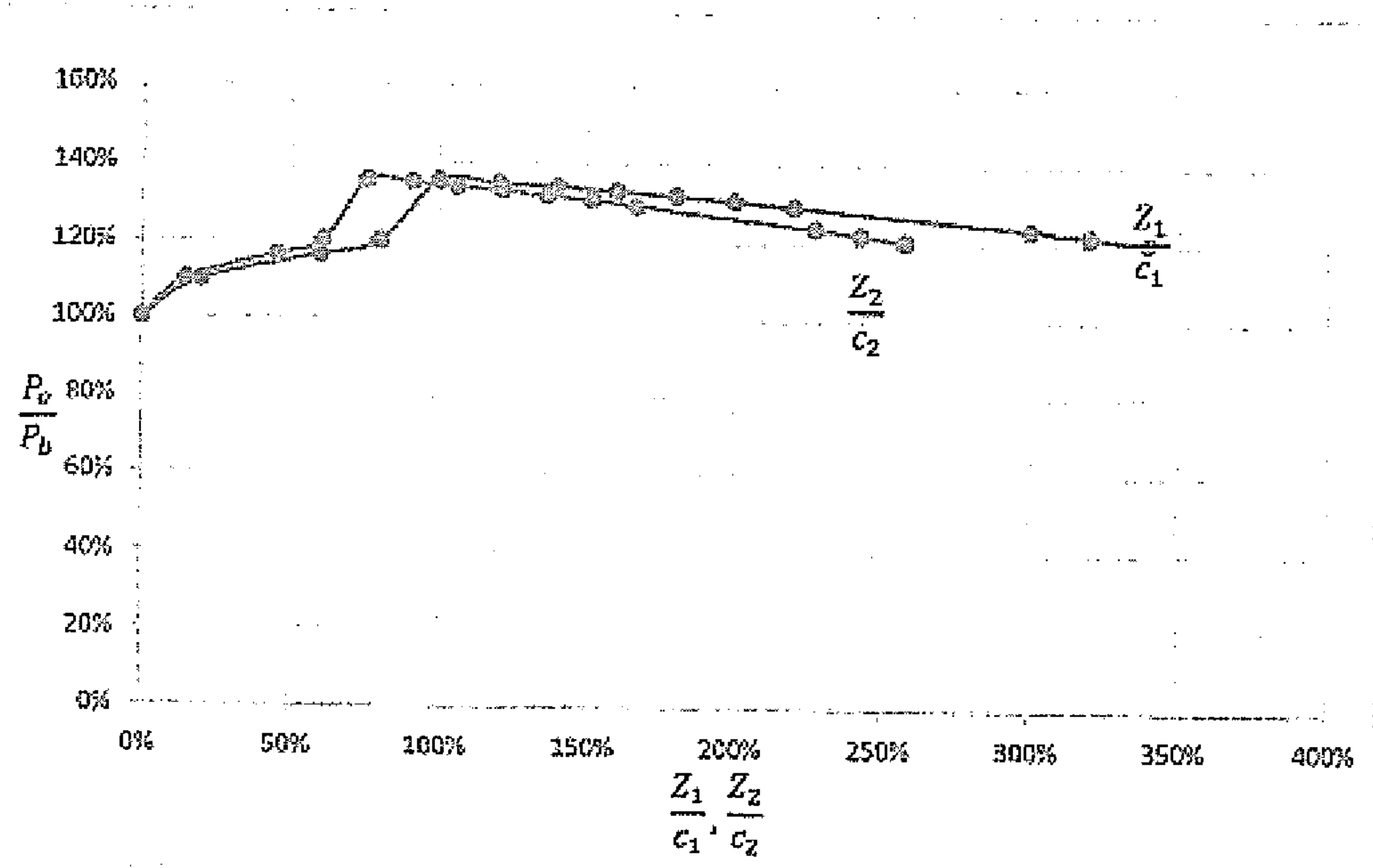

Fig.13

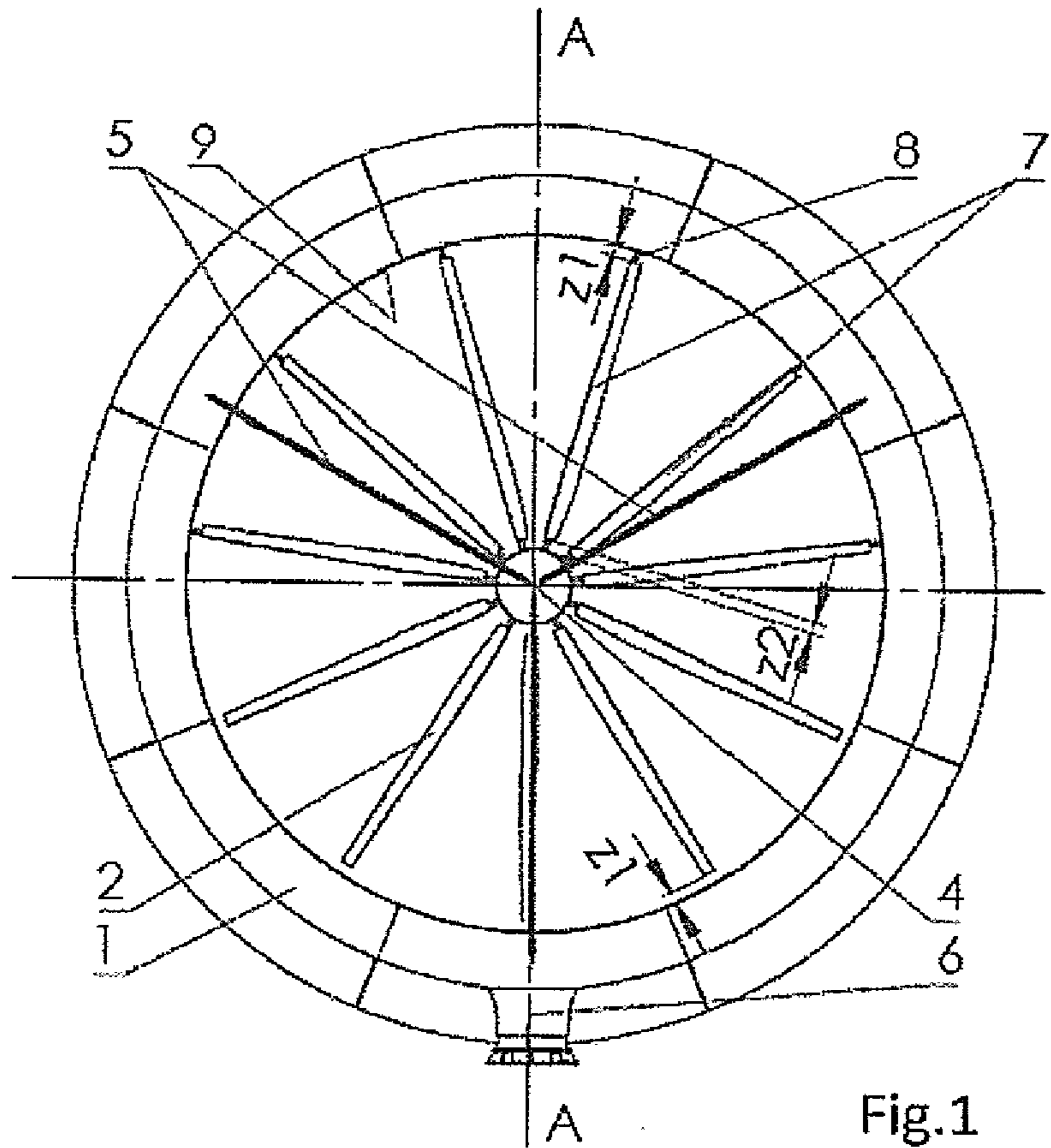

Fig.1

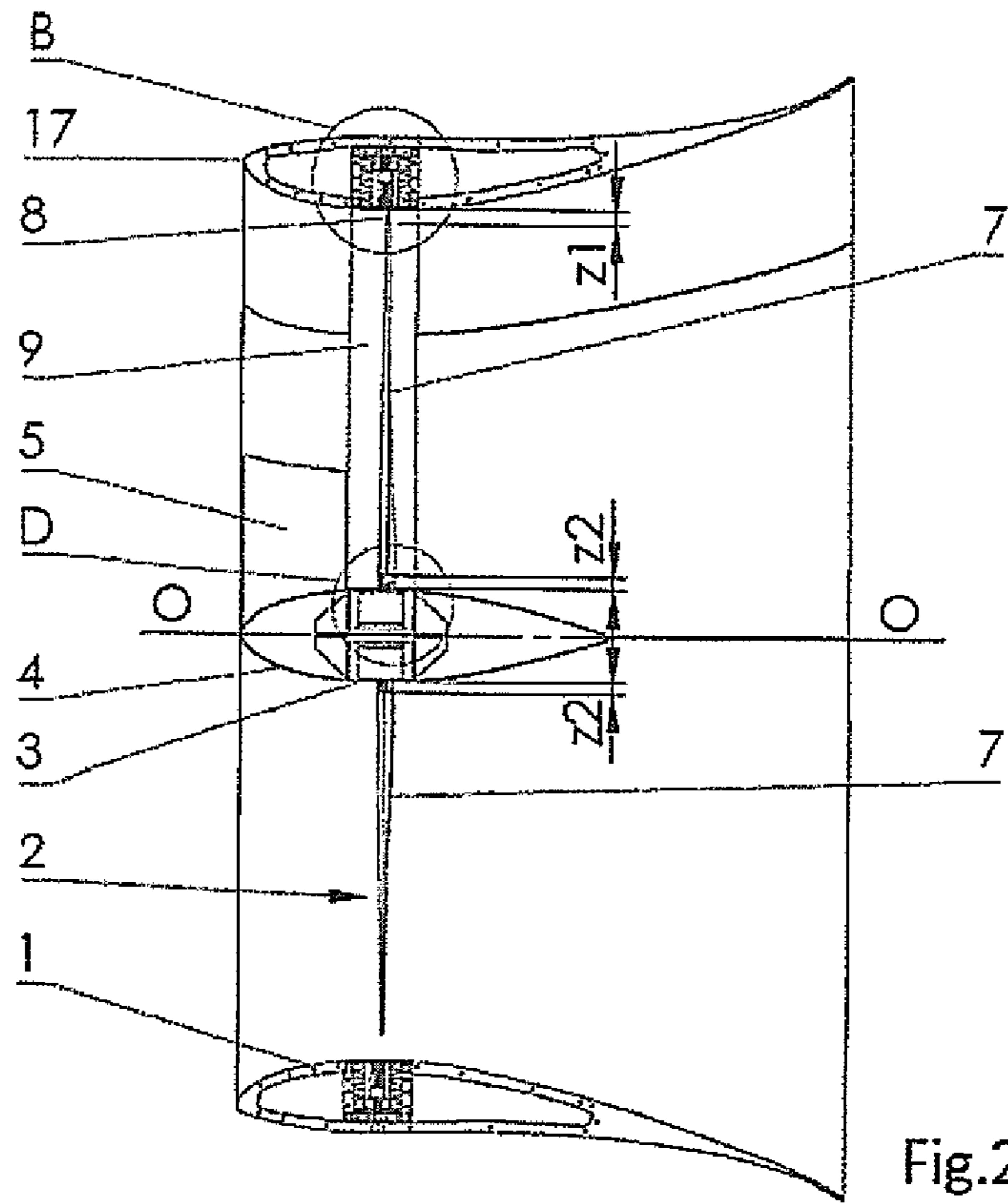

Fig.2