

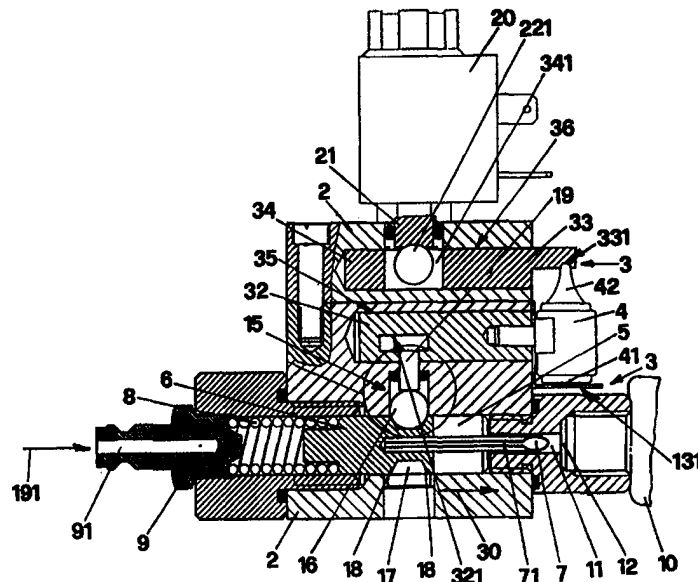

## INTERNATIONAL APPLICATION PUBLISHED UNDER THE PATENT COOPERATION TREATY (PCT)

<p>(51) International Patent Classification <sup>6</sup> : A62C 2/24, E05F 15/20</p>	<p>A1</p>	<p>(11) International Publication Number: <b>WO 98/50112</b> (43) International Publication Date: 12 November 1998 (12.11.98)</p>
<p>(21) International Application Number: PCT/EP98/02663 (22) International Filing Date: 6 May 1998 (06.05.98) (30) Priority Data: VI97A000067 8 May 1997 (08.05.97) IT (71)(72) Applicants and Inventors: CAODURO, Carlo [IT/IT]; Via Roma, 26, I-36010 Monticello Conte Otto (IT). CAO- DURO, Paolo [IT/IT]; Via Europa, 15, I-36010 Zanè (IT). (74) Agent: BONINI, Ercole; Studio Ing. E. Bonini s.r.l., Corso Fogazzaro, 8, I-36100 Vicenza (IT).</p>	<p>(81) Designated States: CZ, PL, SK, European patent (AT, BE, CH, CY, DE, DK, ES, FI, FR, GB, GR, IE, IT, LU, MC, NL, PT, SE).  <b>Published</b> <i>With international search report. Before the expiration of the time limit for amending the claims and to be republished in the event of the receipt of amendments.</i></p>	

(54) Title: SAFETY DEVICE FOR AUTOMATIC CONTROL FOR THE OPENING OF SKYLIGHTS, WINDOWS OR DOORS



## (57) Abstract

The invention realises a safety device (1) for automatic control for the opening of skylights comprising: a valve body (2) with which a thermosensitive bulb (4), a bomb (10) containing pressurised gas for feeding the actuator of the opening of the skylight and a solenoid (20) whose movable element (21) cooperates with blocking means (3) of said bulb (4), are connected. A piston (6) coupled in said valve body (2) is supplied with a pin (7) suitable for piercing the membrane (12) which intercepts the delivery mouth (11) of said bomb (10) in order to feed said actuator when said movable element (21) releases said bulb (4).

**FOR THE PURPOSES OF INFORMATION ONLY**

Codes used to identify States party to the PCT on the front pages of pamphlets publishing international applications under the PCT.

<b>AL</b>	Albania	<b>ES</b>	Spain	<b>LS</b>	Lesotho	<b>SI</b>	Slovenia
<b>AM</b>	Armenia	<b>FI</b>	Finland	<b>LT</b>	Lithuania	<b>SK</b>	Slovakia
<b>AT</b>	Austria	<b>FR</b>	France	<b>LU</b>	Luxembourg	<b>SN</b>	Senegal
<b>AU</b>	Australia	<b>GA</b>	Gabon	<b>LV</b>	Latvia	<b>SZ</b>	Swaziland
<b>AZ</b>	Azerbaijan	<b>GB</b>	United Kingdom	<b>MC</b>	Monaco	<b>TD</b>	Chad
<b>BA</b>	Bosnia and Herzegovina	<b>GE</b>	Georgia	<b>MD</b>	Republic of Moldova	<b>TG</b>	Togo
<b>BB</b>	Barbados	<b>GH</b>	Ghana	<b>MG</b>	Madagascar	<b>TJ</b>	Tajikistan
<b>BE</b>	Belgium	<b>GN</b>	Guinea	<b>MK</b>	The former Yugoslav Republic of Macedonia	<b>TM</b>	Turkmenistan
<b>BF</b>	Burkina Faso	<b>GR</b>	Greece	<b>ML</b>	Mali	<b>TR</b>	Turkey
<b>BG</b>	Bulgaria	<b>HU</b>	Hungary	<b>MN</b>	Mongolia	<b>TT</b>	Trinidad and Tobago
<b>BJ</b>	Benin	<b>IE</b>	Ireland	<b>MR</b>	Mauritania	<b>UA</b>	Ukraine
<b>BR</b>	Brazil	<b>IL</b>	Israel	<b>MW</b>	Malawi	<b>UG</b>	Uganda
<b>BY</b>	Belarus	<b>IS</b>	Iceland	<b>MX</b>	Mexico	<b>US</b>	United States of America
<b>CA</b>	Canada	<b>IT</b>	Italy	<b>NE</b>	Niger	<b>UZ</b>	Uzbekistan
<b>CF</b>	Central African Republic	<b>JP</b>	Japan	<b>NL</b>	Netherlands	<b>VN</b>	Viet Nam
<b>CG</b>	Congo	<b>KE</b>	Kenya	<b>NO</b>	Norway	<b>YU</b>	Yugoslavia
<b>CH</b>	Switzerland	<b>KG</b>	Kyrgyzstan	<b>NZ</b>	New Zealand	<b>ZW</b>	Zimbabwe
<b>CI</b>	Côte d'Ivoire	<b>KP</b>	Democratic People's Republic of Korea	<b>PL</b>	Poland		
<b>CM</b>	Cameroon	<b>KR</b>	Republic of Korea	<b>PT</b>	Portugal		
<b>CN</b>	China	<b>KZ</b>	Kazakstan	<b>RO</b>	Romania		
<b>CU</b>	Cuba	<b>LC</b>	Saint Lucia	<b>RU</b>	Russian Federation		
<b>CZ</b>	Czech Republic	<b>LI</b>	Liechtenstein	<b>SD</b>	Sudan		
<b>DE</b>	Germany	<b>LK</b>	Sri Lanka	<b>SE</b>	Sweden		
<b>DK</b>	Denmark	<b>LR</b>	Liberia	<b>SG</b>	Singapore		
<b>EE</b>	Estonia						

## SAFETY DEVICE FOR AUTOMATIC CONTROL FOR THE OPENING OF SKYLIGHTS, WINDOWS OR DOORS.

The invention concerns a safety device for automatic control for the opening of skylights, windows or doors in case of fire, particularly suitable for being applied to skylights.

It is known that when skylights are present in a building, these should be supplied with provided safety devices suitable for automatically controlling the opening in order to assure, in case of fire, that the products of the combustion are evacuated.

More precisely said safety devices, in case of fire, should be able to feed with pressurised gas, generally CO<sub>2</sub> contained in a bomb, the actuator which controls the opening of the lid of the skylight.

According to an embodiment belonging to the known technique, said safety devices precisely comprise a bomb of pressurised gas whose delivery mouth, which is connected with the conduct that feeds the actuator of the skylight, is sealed with a fracturable membrane. A shutter, provided with a lock mechanism, on which, for the releasing, an actuator supplied with a blasting microcharge piloted by an electric pulse deriving from a hand drive or automatic remote control acts, is arranged frontally to said membrane.

The safety devices belonging to the known technique just described, present the inconvenience that the resistance which lights the detonator by Joule effect, constitutes an ohmic charge which is particularly sensitive to atmospherics, to induced currents, to radio frequency disturbances that are present in the environment in order that the safety device could accidentally intervene in a completely casual way.

Another inconvenience is that the periodical maintenance of such safety devices results rather expensive for the high price of the cartridge which is not reusable any more.

Not last inconvenience is also that such safety devices, every time the intervention of the device itself is simulated in order to verify its working order, or if it is necessary to open the skylight deliberately in order to evacuate fumes or smells which are present in the room, it is necessary to execute a manual intervention which inevitably involves the use of the blasting cartridge which then should be replaced.

In order to eliminate such inconveniences, on behalf of the same depositor of

the present patent, the invention having reference number PD93U000125 has been recorded. This invention describes a safety device which is provided with electromechanical means, in particular with a solenoid, which mechanically intervene on the vial by leverages and permit to remove it without breaking it, when it is necessary to simulate the intervention of the safety device in order to verify its working order or when it is necessary to open manually the skylight. Such safety device presents the advantage of permitting the simulation of the intervention without damaging any component.

Besides, being the solenoid an inductive charge which is not sensitive to the external disturbances of electric nature, the danger of an accidental intervention is eliminated.

Said safety device however presents the inconvenience that the solenoid absorbs a rather high current because it should exercise a considerable thrust on the leverages of removal of the thermosensitive vial in order to realise its release.

In particular, by the realised tests, it has been seen that the solenoid, which is fed by direct 24 Volts current, for working correctly, absorbs a 2 Amperes current.

The solenoids which equip the different safety devices are all in a cascade connection and therefore, particularly in the industrial settlements where a high number of skylights and smoke evacuators is present, it is necessary to arrange electric lines with a suitable section and fed by uninterruptible power supplies which are rather expensive and, first of all, they should be planned by an experienced staff.

The present invention intends to overcome all the mentioned inconveniences. In particular, one of the purposes of the invention is for realising a safety device, particularly suitable for automatically controlling the opening of skylights, supplied with electromechanical driving means which present an absorption of current which is much lower than safety devices belonging to the known technique equivalent to it.

A further purpose is for the safety device of the invention could be manually controlled in order to verify its working order, simulating the opening of the skylight and could be reloaded after the testing intervention.

Not last purpose is for the safety device of the invention could be manually controlled for opening the skylight, at will of the utilizer, without damaging the

thermosensitive vial.

The mentioned purposes are achieved with the realisation of a safety device for the automatic control for the opening of skylights, windows, doors or similars, which according to the main claim comprises:

- 5    – a valve body in which a chamber that communicates with at least a fluid actuator for the opening of said skylight, is realised;
- a piston coupled in said chamber, supplied at one end with a pin and at the other of elastic means suitable for realising its axial sliding in said chamber;
- a bomb containing pressurised gas, supplied with a delivery mouth which  
10   communicates with said chamber and which feeds it with said pressurised gas when said pin pierces a membrane which intercepts said delivery mouth;
- a thermosensitive bulb in between blocking means, suitable for keeping it fixed in position by axial compression exercised by thrust means in contact  
15   with said piston, and it is characterised in that said blocking means of said bulb comprise:
  - a support element which receives one end of said bulb, rotably coupled to said valve body and cooperating with said thrust means;
  - a check element which receives the other end of said bulb, rotably coupled  
20   to said valve body in comparison with which it is made fixed by contrast means cooperating with the movable element of a solenoid, being said thrust means suitable for realising the rotation of said support element with whom they cooperate in order to obtain the release of the whole bulb when said solenoid disconnects said movable element from said contrast means  
25   in order to render said check element of said bulb free of rotating in order to make said piston free of sliding inside said chamber, thrust by elastic means.

According to a preferred embodiment, the support and check elements which form the blocking means in between which the thermosensitive bulb is kept  
30   fixed in position, are coupled with the valve body by pivots, neutral in the seats in which they are coupled.

In particular the intervention of the solenoid consists only in a returning action of the movable element which blocks the rotation of the check element which, when it is free, freely rotates in its own seat, because it is eccentrically thrust  
35   by the shifting of the piston coupled in the cylindrical chamber of the valve

element itself.

Therefore the solenoid could be fed on very reduced currents because it, in a way different from that of the devices belonging to the known technique with electromechanical control, should not realise any thrust action against  
5 mechanic members but it should realise only the function of removing the contrast means which restrain the check element because the proper operation of the safety device happens when the elastic means axially thrust the piston coupled in the cylindrical chamber of the valve body.

Advantageously the use of the safety device of the invention permits, as it has  
10 been said, to use the same electric lines of feeding of the safety devices belonging to the known technique previously mentioned and in case even installed.

Still advantageously in case of new installations, it is possible to realise electrical systems which feed them, less expensive and less complex because  
15 the feeding currents of the safety devices are lower, control points be equal, than the use of safety devices belonging to the known technique equivalent to them.

The purposes and the advantages will be better pointed out during the description of a preferred embodiment of the invention given as an example  
20 but not as a restriction and which refers to the enclosed drawings where:

- fig. 1 shows the safety device of the invention in a longitudinal section and in a rest position;
- fig. 2 shows a particular of fig. 1;
- fig. 3 shows the safety device represented in fig. 1, seen on the side of the  
25 thermosensitive bulb;
- fig. 4 shows a particular of the device represented in fig. 3;
- fig. 5 shows the safety device of the invention represented in a longitudinal section, in the configuration that it assumes when it is activated;
- fig. 6 shows a particular of the device represented in fig. 5;
- 30 – fig. 7 shows the side view of the safety device represented in fig. 5, partially sectioned in correspondence of the movable element of the solenoid;
- fig. 8 shows the enlargement of the particular corresponding with the movable element of the solenoid.

As fig. 1 shows, the safety device of the invention, indicated as a whole with 1,  
35 is formed of a valve body 2 which is outside supplied with blocking means 3

suitable for supporting a thermosensitive bulb 4 and inside it presents a chamber 5 in which a piston 6, supplied at one end with a pin 7 and at the other with elastic means 8 suitable for realising, by thrust, the axial sliding, slides.

5 It can be also observed that on one side a sleeve 9 which puts in communication said chamber 5 with the actuator of the skylight, both of them represented in figure, is applied to said valve body 2. While on the opposite side and in correspondence of the pin 7 a bomb 10 containing inert pressurised gas, where said bomb presents a delivery mouth 11 which  
10 communicates with said chamber 5 and is closed by a fracturable membrane 12, is applied to the valve body.

As regards said blocking means 3 of said bulb 4, it can be observed that they comprise:

- 15 – a support element 31 which receives one end 41 of said bulb 4 and it is supplied with a first pivot 32 rotably coupled in a seat 35 arranged in the valve body 2;
- a check element 33 which receives another end 42 of the same bulb 4 and it is supplied with another pivot 34 coupled in another seat 36 arranged in the same valve body 2.

20 It can be finally observed that said first pivot 32 of said support element 31 cooperates with thrust means, indicated as a whole with 15, and visible with more details in fig. 3, which comprise a sphere 16 arranged in an annular niche 17 with conical opposite walls 18, realised in the body of said piston 6. Said sphere 16, as also fig. 2 shows in particular, is sliding coupled inside a seat  
25 180 realised in the valve body 2 and it is put in contact with a thrust spindle (19) which slides in the same seat 180 and which is opposite to a first plane 321, misaligned of the quantity 190 in comparison with the longitudinal axis of the said first pivot 32 to which it belongs.

In the upper part of the valve body 2 a solenoid 20 whose movable element 21  
30 cooperates with contrast means 22 which are formed of a third pivot 221 that is made elastic by a spring 224, and in contact with a second plane 341 belonging to said second pivot 34, is present.

More precisely, as figs. 4 and 8 show, said third pivot 221 is supplied with a stubbling 222 in which, when the safety device is in a rest position represented  
35 in figs. 1 and 2, the movable element 21 fits in for blocking said third pivot 221

in adherence against said second reference plane 341 of said second pivot 34. When the safety device of the invention is in rest conditions it, as it has just been said, is in the configuration represented in figs. 1 and 3 in which the sphere 16 is arranged in the annular niche 17 of the piston 6 and it is pushed upwards by the lateral conical walls 18 in order that the thrust spindle 19 is in contact with the first plane 321, misaligned of the quantity 190 in comparison with the axis of the first pivot 32 to which said first plane 321 belongs.

The movable element 21 keeps the third pivot 221 blocked in the position of fig. 3 and being opposite to the second reference plane 341 of the second pivot 34 it prevents this one from rotating. Consequently the thermosensitive bulb 4, which presents the end 41 and 42 arranged respectively in the first seat 131 of the support element 31 and in the second seat 331 of the check element 33, it is blocked in position by the axial compression exercised by said thrust means 15.

In such a situation the piston 6 remains in the position represented in fig. 1 where, even if the spring 8 is loaded, it is blocked by the presence of the sphere 16 which prevents its approach towards the bomb 10 according to the direction 30 in order that the pin 7 with which it is supplied, is detached from the fracturable membrane 12.

In such a position the actuator which opens the skylight is not activated by the fluid which is in the bomb 10 and therefore the skylight itself remain closed.

In case of fire, the thermosensitive bulb 4 fractures and the first pivot 32 of the support element 31 can rotate neutral on its longitudinal axis because it is not blocked any more in position by the interposition of the stiff body which prevented its rotation and formed of the bulb 4.

The thrust spindle 19 can therefore move upwards pushed by the sphere 16 which lifts itself by the axial thrust on the piston 6 exercised by the elastic recovery of the spring 8 which, as fig. 5 shows, brings the pin 7 in order to pierce the fracturable membrane 12 of the bomb 10.

During such movements, the check element 33 is fixed in position.

The inert pressurised gas flows through the inner conduct 71 of the pin 7 in order to arrive at the conduct 91 of the sleeve 9 from which, by a pipe - line not represented, is brought inside the actuator of the skylight, obtaining its opening.

It can be observed that the inert pressurised gas which fills also the chamber

180, can't outwardly flow passing through the clearances present in the elements which form the safety device because, as fig. 6 shows, the gasket 181 of the OR kind arranged in the chamber 180, contrasts watertight against the sphere 16 preventing the passing through of the compressed fluid.

5 This happens in case in which the safety device intervenes in case of fire.

After the intervention of the safety device, it is restored in a rest position, represented in figs. 1 and 3, manually applying a rotation to the support element 31 and to the overhanging check element 33, in order to reposition the bulb which is ready for further intervention.

10 The skylight is manually closed and the fluid which is inside the actuator and that has permitted the opening, is discharged in the environment through the adduction pipe - line, not represented, the conduct 91 of the sleeve 9 which is crossed according to the direction 191 and the seat 180, from which it discharges outside passing through the clearances among the members which  
15 form the safety device not being, as fig. 1 and also fig. 2 show, the sphere 16 watertight against the gasket 181.

However, it is possible to obtain the intervention of the safety device itself manually controlling it in order to open deliberately the skylight even in case in which there is no fire or for verifying its working order.

20 In such a case by the switching off of an interrupter, not represented in figure, the solenoid 20 which, as figs. 7 and 8 show, disengages the movable element 21 from the stubbling 222 arranged in the third pivot 221 which, not being mechanically blocked any more, withdraws according to the direction 223 compressing the spring 224 and releasing the second pivot 34 permitting it to  
25 rotate on its axis, is excited.

The thrust to which the bulb 4 is subjected by action of the thrust means 15 and particularly of the thrust spindle 19 forced by the sphere 16, causes the rotation of the second pivot 34 itself whose second seat 331 frees the bulb 4. This one unhooks therefore also from the first seat 131 by which it is united to  
30 the support element 31 and therefore makes neutral also the first pivot 32 which is rotated on its turn by the lift of the thrust spindle 19 for the sliding of the piston 6 caused by the thrust of the spring 8.

Also in this case the progress of the pin 7 which comes in the configuration represented in fig. 5, is obtained.

35 It is clear that if the intent of the utilizer is that of activating the safety device

only for verifying its working order, he will make sure, before activating it, of removing the bomb 10 in order to prevent the piercing of the membrane and of arranging for receiving the bulb 4 when this is released by the blocking means. Vice - versa in case the utilizer proceeds to open the skylight by the pressurised gas contained in the bomb, he will be able to recover only the thermosensitive bulb.

After any intervention of the automatic or manual safety device, it is necessary, as it has been said in advance, to recover it in a rest position represented in figs. 1 and 3, manually applying a rotation to the support element 31 and to the overhanging check element 33 in order to reposition the bulb 4, ready for further interventions.

It is possible to comprehend, therefore, on the basis of what has been said, that the safety device of the invention achieves all the prefixed purposes. In particular the purpose for obtaining the operation of the safety device using solenoids which are fed on lower currents than the necessary ones for feeding the solenoids which equip the safety devices belonging to the known technique and in particular the safety device described in the mentioned patent having reference number PD93U000125 on behalf of the same inventor of the present patent, is achieved.

Indeed, only a shift of the movable element 21 with which it is supplied, is asked to the solenoid 20 of the safety device of the invention and therefore it doesn't make any thrust action against any mechanical member. Consequently it should be of a small power and absorb a limited current which experimental tests, realised on prototypes, have permitted to define on values of about 250 mA.

It has also been seen how it is possible to make the safety device of the invention intervening manually and by control of the operator, for example for verifying the working order without destroying the thermosensitive bulb and using the pressurised gas contained in the bomb.

Besides, the limited value of current which the solenoid absorbs and that experimental tests have indicated of about 250 mA. permits to install the safety device of the invention even in replacement of electric or electromechanical safety devices belonging to the known technique, without replacing or however modifying the feeding electric lines.

During the feeding phase modifications which, however, if based on the same

idea of solution described, are all to be considered protected by the present patent, could be made.

## CLAIMS

1) Safety device (1) for the automatic control for the opening of skylights, windows, doors and similars comprising:

- 5 – a valve body (2) in which a chamber (5) which communicates with at least a fluid actuator for the opening of said skylight is realised;
- a piston (6) coupled in said chamber (5), supplied at one end with a pin (7) and at the other end with elastic means (8) suitable for realising its axial sliding in said chamber (5);
- 10 – a bomb (10) containing pressurised gas, supplied with a delivery mouth (11) which communicates with said chamber (5) and which feeds it with said pressurised gas when said pin (7) pierces a membrane (12) which intercepts said delivery mouth (11);
- a thermosensitive bulb (4) in between blocking means suitable for keeping it fixed in position by axial compression exercised by thrust means (15) in  
15 contact with said piston (6), **characterised in that** said blocking means (3) of said bulb (4) comprise:
  - a support element (31) which receives a first end (41) of said bulb (4), rotably coupled with said valve body (2) and cooperating with said thrust means (15);
  - 20 – a check element (33) which receives a second end (42) of said bulb (4), rotably coupled with said valve body (2) in comparison with which it is blocked by contrast means (22) cooperating with the movable element (21) of a solenoid (20), being said thrust means (15) suitable for realising the rotation of said support element (31) with which they cooperate in order to  
25 obtain the release of the whole bulb (4) when said solenoid (20) disconnects said movable element (21) from said contrast means (22) in order to make this check element (33) of said bulb (4) free of rotating in order to make said piston (6) free of sliding inside said chamber (5), thrust by said elastic means (8).

- 30 2) Safety device (1) according to the claim 1) **characterised in that** said support element (31) which receives said first end (41) of said bulb (4) is supplied with a first cylindrical pivot (32) which mates neutral in a first hole (35) arranged in said valve body (2), being said first cylindrical pivot (32) supplied with a first reference plane (321) suitable for cooperating with said thrust  
35 means (15) in contact with said piston (6).

3) Safety device (1) according to the claim 2) **characterised in that** said thrust means (15) comprise a sphere (16) arranged in an annular niche (17) with conical opposite walls (18) realised in the body of said piston (6), being said sphere (16) sliding coupled inside a seat (180) realised in the valve body (2) orthogonally to the longitudinal axis of said piston (6) and being put in contact with a thrust spindle (19) which contrasts against said first reference plane (321) of said first cylindrical pivot (32) belonging to said support element (31).

4) Safety device (1) according to the claim 3) **characterised in that** inside said seat (180) realised in the valve body (2) a gasket (181) of the OR kind, inside which said thrust spindle (19) is sliding coupled, is present, contrasting said gasket (181) against said sphere (16) when said conical opposite walls (18) of said annular niche (17) force said sphere (16) against said gasket (181).

5) Safety device (1) according to the claim 3) **characterised in that** said thrust spindle (19) presents the orthogonal longitudinal axis and misaligned in comparison with the longitudinal axis of said first cylindrical pivot (32) in order to realise with said first reference plane (321) an eccentric contact, in order to obtain the rotation of said first cylindrical pivot (32) on its longitudinal axis when the axial shifting of said piston (6) forces said thrust spindle (19) against said first reference plane (321).

6) Safety device (1) according to the claim 1) **characterised in that** said check element (33) which receives said second end (42) of said bulb (4) is formed of a second cylindrical pivot (34) which mates neutral in a second hole (36) realised in said valve body (2) and which presents an end protruding from the valve body itself supplied with a second seat (331) suitable for receiving said second end (42) of said bulb (4), said second pivot (34) presenting, in an intermediate position, a second reference plane (341) in contact with contrast means (15) belonging to the valve body (2) itself and cooperating with said movable element (21) of said solenoid (210).

1/2

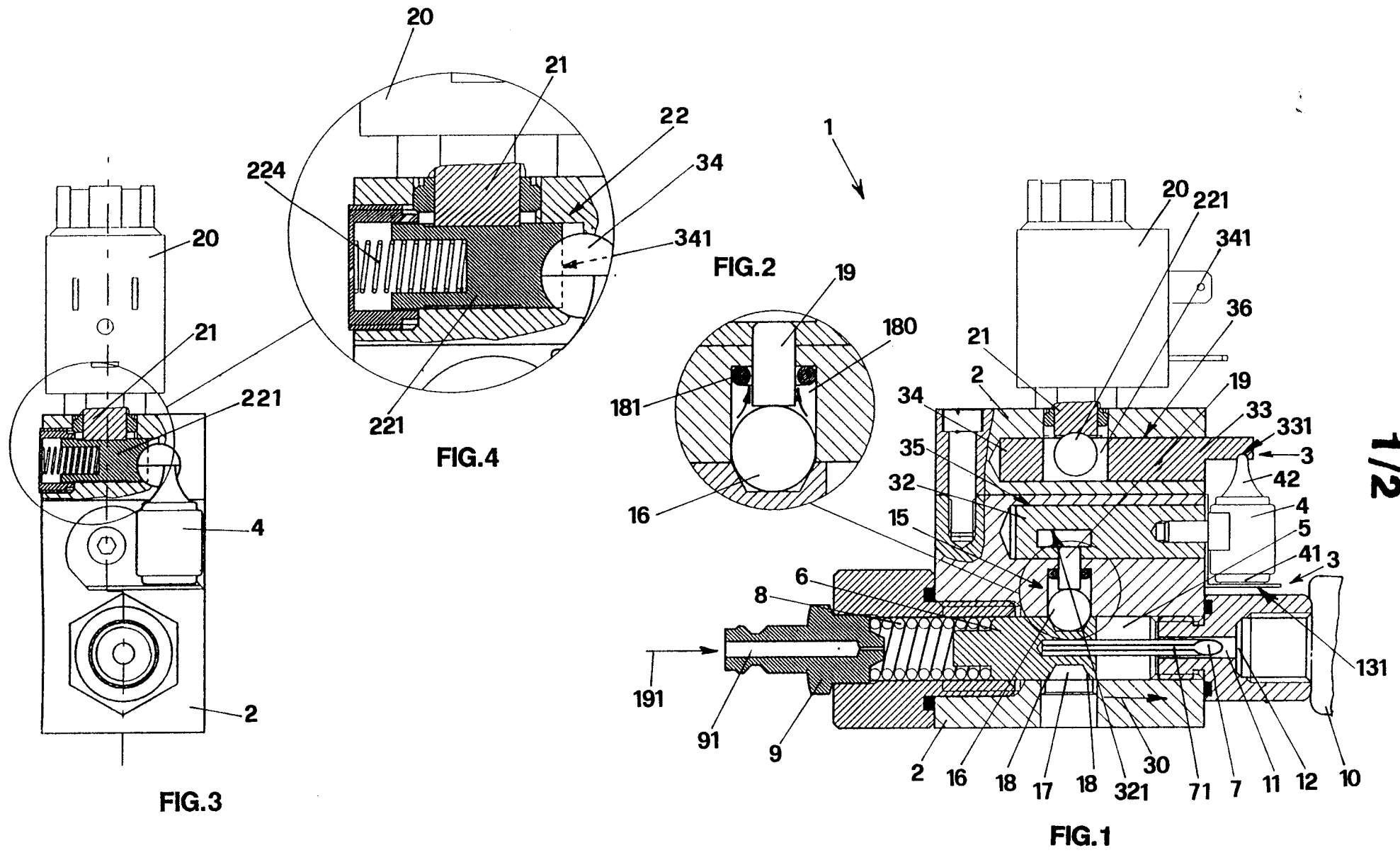

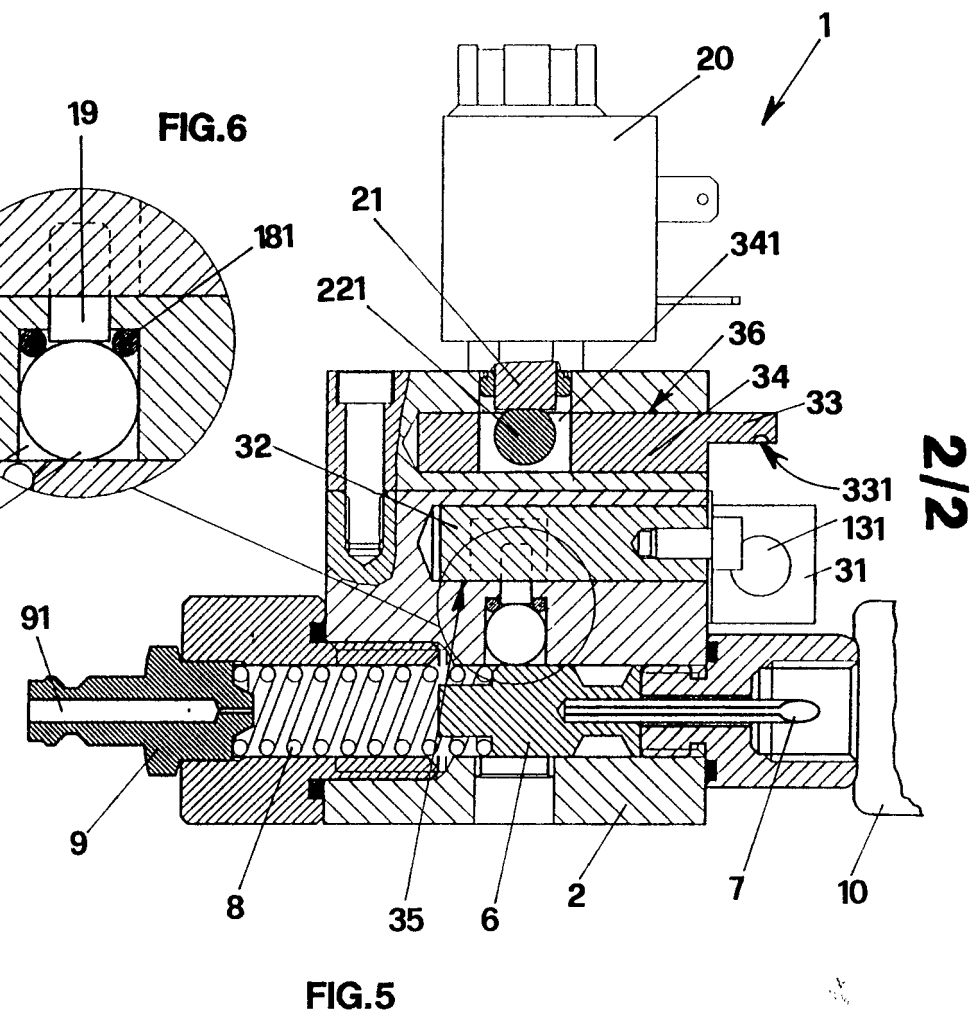
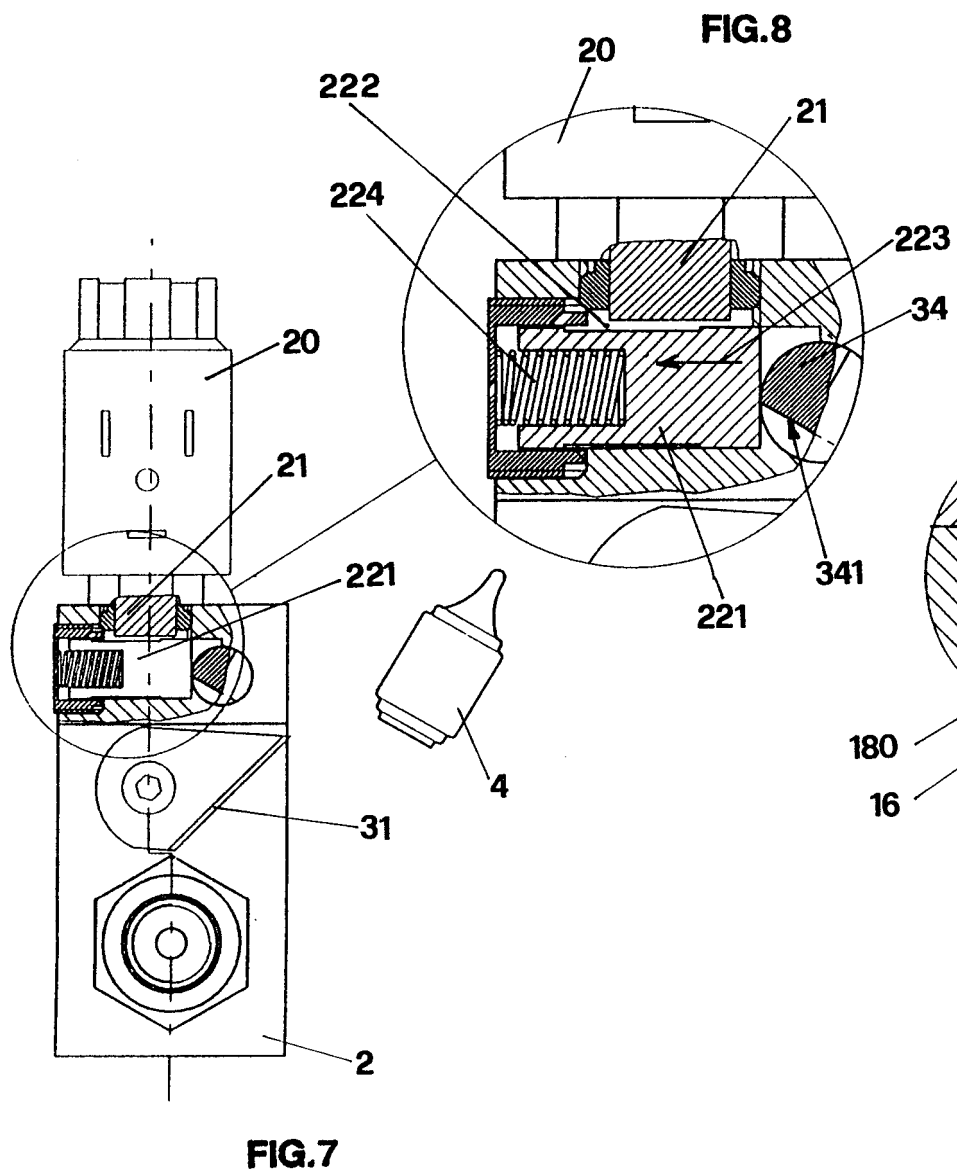

2/2

# INTERNATIONAL SEARCH REPORT

International Application No

PCT/EP 98/02663

**A. CLASSIFICATION OF SUBJECT MATTER**  
 IPC 6 A62C2/24 E05F15/20

According to International Patent Classification (IPC) or to both national classification and IPC

**B. FIELDS SEARCHED**

Minimum documentation searched (classification system followed by classification symbols)  
 IPC 6 A62C E05F

Documentation searched other than minimum documentation to the extent that such documents are included in the fields searched

Electronic data base consulted during the international search (name of data base and, where practical, search terms used)

**C. DOCUMENTS CONSIDERED TO BE RELEVANT**

Category °	Citation of document, with indication, where appropriate, of the relevant passages	Relevant to claim No.
A	DE 24 34 049 A (FORTMEIER) 5 February 1976 see page 1 - page 4; figures ---	1, 3
A	DE 35 12 039 A (FORTMEIER) 9 October 1986 see abstract -----	3, 4

Further documents are listed in the continuation of box C.

Patent family members are listed in annex.

° Special categories of cited documents :

- "A" document defining the general state of the art which is not considered to be of particular relevance
- "E" earlier document but published on or after the international filing date
- "L" document which may throw doubts on priority claim(s) or which is cited to establish the publication date of another citation or other special reason (as specified)
- "O" document referring to an oral disclosure, use, exhibition or other means
- "P" document published prior to the international filing date but later than the priority date claimed

- "T" later document published after the international filing date or priority date and not in conflict with the application but cited to understand the principle or theory underlying the invention
- "X" document of particular relevance; the claimed invention cannot be considered novel or cannot be considered to involve an inventive step when the document is taken alone
- "Y" document of particular relevance; the claimed invention cannot be considered to involve an inventive step when the document is combined with one or more other such documents, such combination being obvious to a person skilled in the art.
- "&" document member of the same patent family

Date of the actual completion of the international search

20 October 1998

Date of mailing of the international search report

27/10/1998

Name and mailing address of the ISA

European Patent Office, P.B. 5818 Patentlaan 2  
 NL - 2280 HV Rijswijk  
 Tel. (+31-70) 340-2040, Tx. 31 651 epo nl,  
 Fax: (+31-70) 340-3016

Authorized officer

Van Kessel, J

# INTERNATIONAL SEARCH REPORT

Information on patent family members

International Application No

PCT/EP 98/02663

Patent document cited in search report	Publication date	Patent family member(s)	Publication date
DE 2434049 A	05-02-1976	AT 347101 B	11-12-1978
		AT 500575 A	15-04-1978
		DK 320475 A,B	17-01-1976
-----			
DE 3512039 A	09-10-1986	NONE	
-----			