

(19) World Intellectual Property Organization  
International Bureau



(43) International Publication Date  
14 August 2003 (14.08.2003)

PCT

(10) International Publication Number  
**WO 03/065916 A1**

- (51) International Patent Classification<sup>7</sup>: **A61B 18/14**
- (21) International Application Number: PCT/US03/03507
- (22) International Filing Date: 5 February 2003 (05.02.2003)
- (25) Filing Language: English
- (26) Publication Language: English
- (30) Priority Data:  
10/072,610 6 February 2002 (06.02.2002) US
- (71) Applicant (for all designated States except US): **THERMAGE, INC.** [US/US]; 4058 Point Eden Way, Hayward, CA 94545 (US).
- (72) Inventors; and
- (75) Inventors/Applicants (for US only): **STERN, Roger** [US/US]; 10418 Palo Vista Road, Cupertino, CA 95014 (US). **LEVINSON, Mitchell** [US/US]; 7924 Spyglass Court, Pleasanton, CA 94588 (US). **WEBER, Bryan** [US/US]; 2612 Tahoe Drive, Livermore, CA 94550 (US).
- (74) Agent: **DAVIS, Paul**; Heller Ehrman White & McAuliffe, 275 Middlefield Road, Menlo Park, CA 94025-3506 (US).
- (81) Designated States (national): AE, AG, AL, AM, AT, AU, AZ, BA, BB, BG, BR, BY, BZ, CA, CH, CN, CO, CR, CU, CZ, DE, DK, DM, DZ, EC, EE, ES, FI (utility model), FI, GB, GD, GE, GH, GM, HR, HU, ID, IL, IN, IS, JP, KE, KG, KP, KR, KZ, LC, LK, LR, LS, LT, LU, LV, MA, MD, MG, MK, MN, MW, MX, MZ, NO, NZ, OM, PH, PL, PT, RO, RU, SD, SE, SG, SK, SL, TJ, TM, TN, TR, TT, TZ, UA, UG, US, UZ, VC, VN, YU, ZA, ZM, ZW.
- (84) Designated States (regional): ARIPO patent (GH, GM, KE, LS, MW, MZ, SD, SL, SZ, TZ, UG, ZM, ZW), Eurasian patent (AM, AZ, BY, KG, KZ, MD, RU, TJ, TM), European patent (AT, BE, BG, CH, CY, CZ, DE, DK, EE, ES, FI, FR, GB, GR, HU, IE, IT, LU, MC, NL, PT, SE, SI, SK, TR), OAPI patent (BF, BJ, CF, CG, CI, CM, GA, GN, GQ, GW, ML, MR, NE, SN, TD, TG).
- Published:  
— with international search report

[Continued on next page]

(54) Title: HANDPIECE FOR RF TREATMENT OF TISSUE

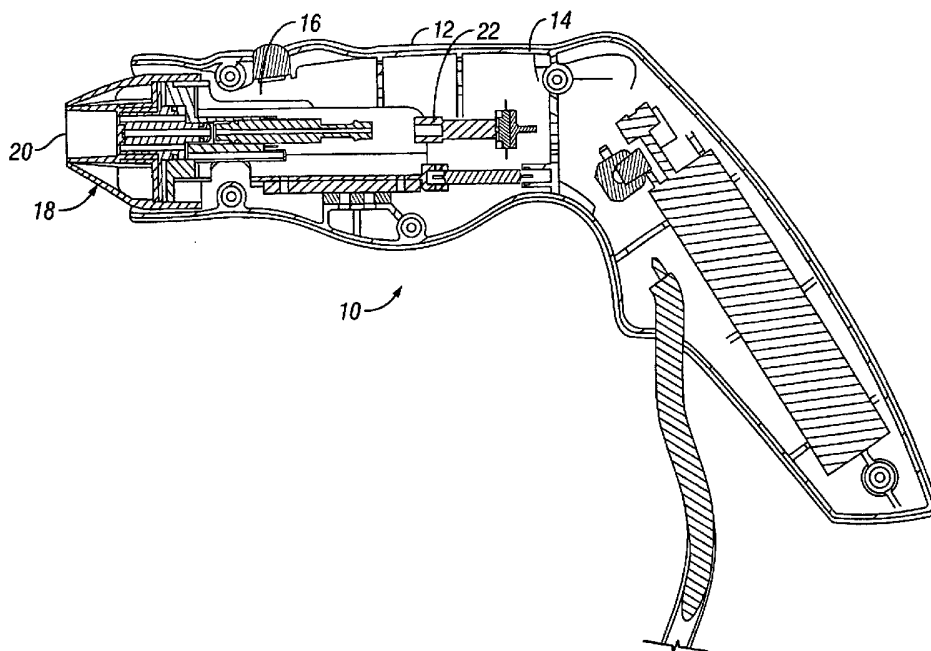

(57) Abstract: A handpiece that includes a handpiece assembly, a handpiece housing and a cooling fluidic medium valve member. An electrode assembly is coupled to the handpiece housing. The electrode assembly has at least one RF electrode that is capacitively coupled to a skin surface when at least a portion of the RF electrode is in contact with the skin surface.



WO 03/065916 A1



— *before the expiration of the time limit for amending the claims and to be republished in the event of receipt of amendments*

*For two-letter codes and other abbreviations, refer to the "Guidance Notes on Codes and Abbreviations" appearing at the beginning of each regular issue of the PCT Gazette.*

## HANDPIECE FOR RF TREATMENT OF TISSUE

### Cross-Reference to Related Applications

This application is a continuation-in-part of U.S. Serial No. 09/522,275, filed 09-  
5 Mar-2000, which claims priority to U.S. Application No. 60/123,440, filed March 9, 1999,  
both of which are fully incorporated herein by reference.

### Field of the Invention

This invention relates generally to a handpiece for treating tissue, and more  
10 particularly, to an RF electrode handpiece for treating skin and underlying tissues.

### Description of Related Art

The human skin is composed of two elements: the epidermis and the underlying  
dermis. The epidermis with the stratum corneum serves as a biological barrier to the  
15 environment. In the basilar layer of the epidermis, pigment-forming cells called  
melanocytes are present. They are the main determinants of skin color.

The underlying dermis provides the main structural support of the skin. It is  
composed mainly of an extra-cellular protein called collagen. Collagen is produced by  
fibroblasts and synthesized as a triple helix with three polypeptide chains that are  
20 connected with heat labile and heat stable chemical bonds. When collagen-containing  
tissue is heated, alterations in the physical properties of this protein matrix occur at a  
characteristic temperature. The structural transition of collagen contraction occurs at a  
specific "shrinkage" temperature. The shrinkage and remodeling of the collagen matrix  
with heat is the basis for the technology.

25 Collagen crosslinks are either intramolecular (covalent or hydrogen bond) or  
intermolecular (covalent or ionic bonds). The thermal cleavage of intramolecular  
hydrogen crosslinks is a scalar process that is created by the balance between cleavage  
events and relaxation events (reforming of hydrogen bonds). No external force is  
required for this process to occur. As a result, intermolecular stress is created by the  
30 thermal cleavage of intramolecular hydrogen bonds. Essentially, the contraction of the  
tertiary structure of the molecule creates the initial intermolecular vector of contraction.

Collagen fibrils in a matrix exhibit a variety of spatial orientations. The matrix is  
lengthened if the sum of all vectors acts to distract the fibril. Contraction of the matrix

is facilitated if the sum of all extrinsic vectors acts to shorten the fibril. Thermal disruption of intramolecular hydrogen bonds and mechanical cleavage of intermolecular crosslinks is also affected by relaxation events that restore preexisting configurations. However, a permanent change of molecular length will occur if crosslinks are reformed  
5 after lengthening or contraction of the collagen fibril. The continuous application of an external mechanical force will increase the probability of crosslinks forming after lengthening or contraction of the fibril.

Hydrogen bond cleavage is a quantum mechanical event that requires a threshold of energy. The amount of (intramolecular) hydrogen bond cleavage required  
10 corresponds to the combined ionic and covalent intermolecular bond strengths within the collagen fibril. Until this threshold is reached, little or no change in the quaternary structure of the collagen fibril will occur. When the intermolecular stress is adequate, cleavage of the ionic and covalent bonds will occur. Typically, the intermolecular cleavage of ionic and covalent bonds will occur with a ratcheting effect from the  
15 realignment of polar and nonpolar regions in the lengthened or contracted fibril.

Cleavage of collagen bonds also occurs at lower temperatures but at a lower rate. Low-level thermal cleavage is frequently associated with relaxation phenomena in which bonds are reformed without a net change in molecular length. An external force that mechanically cleaves the fibril will reduce the probability of relaxation phenomena  
20 and provides a means to lengthen or contract the collagen matrix at lower temperatures while reducing the potential of surface ablation.

Soft tissue remodeling is a biophysical phenomenon that occurs at cellular and molecular levels. Molecular contraction or partial denaturization of collagen involves the application of an energy source, which destabilizes the longitudinal axis of the molecule  
25 by cleaving the heat labile bonds of the triple helix. As a result, stress is created to break the intermolecular bonds of the matrix. This is essentially an immediate extra-cellular process, whereas cellular contraction requires a lag period for the migration and multiplication of fibroblasts into the wound as provided by the wound healing sequence. In higher developed animal species, the wound healing response to injury involves an  
30 initial inflammatory process that subsequently leads to the deposition of scar tissue.

The initial inflammatory response consists of the infiltration by white blood cells or leukocytes that dispose of cellular debris. Seventy-two hours later, proliferation of fibroblasts at the injured site occurs. These cells differentiate into contractile myofibroblasts, which are the source of cellular soft tissue contraction. Following

cellular contraction, collagen is laid down as a static supporting matrix in the tightened soft tissue structure. The deposition and subsequent remodeling of this nascent scar matrix provides the means to alter the consistency and geometry of soft tissue for aesthetic purposes.

5           In light of the preceding discussion, there are a number of dermatological procedures that lend themselves to treatments which deliver thermal energy to the skin and underlying tissue to cause a contraction of collagen, and/or initiate a wound healing response. Such procedures include skin remodeling/resurfacing, wrinkle removal, and treatment of the sebaceous glands, hair follicles adipose tissue and spider veins.

10           Currently available technologies that deliver thermal energy to the skin and underlying tissue include Radio Frequency (RF), optical (laser) and other forms of electromagnetic energy. However, these technologies have a number of technical limitations and clinical issues which limit the effectiveness of the treatment and/or preclude treatment altogether. These issues include the following: i) achieving a uniform thermal effect

15           across a large area of tissue, ii) controlling the depth of the thermal effect to target selected tissue and prevent unwanted thermal damage to both target and non-target tissue, iii) reducing adverse tissue effects such as burns, redness blistering, iv) replacing the practice of delivery energy/treatment in a patchwork fashion with a more continuous delivery of treatment (e.g. by a sliding or painting motion), v) improving

20           access to difficult-to-reach areas of the skin surface and vi) reducing procedure time and number of patient visits required to complete treatment. As will be discussed herein the current invention provides an apparatus for solving these and other limitations.

          One of the key shortcomings of currently available RF technology for treating the

25           skin is the edge effect phenomenon. In general, when RF energy is being applied or delivered to tissue through an electrode which is in contact with that tissue, the current patterns concentrate around the edges of the electrode, sharp edges in particular. This effect is generally known as the edge effect. In the case of a circular disc electrode, the effect manifests as a higher current density around the perimeter of that circular

30           disc and a relatively low current density in the center. For a square-shaped electrode there is typically a high current density around the entire perimeter, and an even higher current density at the corners where there is a sharp edge.

          Edge effects cause problems in treating the skin for several reasons. First, they result in a non-uniform thermal effect over the electrode surface. In various

treatments of the skin, it is important to have a uniform thermal effect over a relatively large surface area, particularly for dermatologic treatments. Large in this case being on the order of several square millimeters or even several square centimeters. In electrosurgical applications for cutting tissue, there typically is a point type applicator  
5 designed with the goal of getting a hot spot at that point for cutting or even coagulating tissue. However, this point design is undesirable for creating a reasonably gentle thermal effect over a large surface area. What is needed is an electrode design to deliver uniform thermal energy to skin and underlying tissue without hot spots.

A uniform thermal effect is particularly important when cooling is combined with  
10 heating in skin/tissue treatment procedure. As is discussed below, a non-uniform thermal pattern makes cooling of the skin difficult and hence the resulting treatment process as well. When heating the skin with RF energy, the tissue at the electrode surface tends to be warmest with a decrease in temperature moving deeper into the tissue. One approach to overcome this thermal gradient and create a thermal effect at  
15 a set distance away from the electrode is to cool the layers of skin that are in contact with the electrode. However, cooling of the skin is made difficult if there is a non-uniform heating pattern. If the skin is sufficiently cooled such that there are no burns at the corners of a square or rectangular electrode, or at the perimeter of a circular disc electrode, then there will probably be overcooling in the center and there won't be any  
20 significant thermal effect (i.e. tissue heating) under the center of the electrode. Contrarily, if the cooling effect is decreased to the point where there is a good thermal effect in the center of the electrode, then there probably will not be sufficient cooling to protect tissue in contact with the edges of the electrode. As a result of these  
25 limitations, in the typical application of a standard electrode there is usually an area of non-uniform treatment and/or burns on the skin surface. So uniformity of the heating pattern is very important. It is particularly important in applications treating skin where collagen-containing layers are heated to produce a collagen contraction response for tightening of the skin. For this and related applications, if the collagen contraction and resulting skin tightening effect are non-uniform, then a medically undesirable result may  
30 occur.

There is a need for an improved RF handpiece for cosmetic applications.

### **SUMMARY OF THE INVENTION**

Accordingly, an object of the present invention is to provide an RF handpiece which provides a substantially uniform delivery of energy to a target tissue site.

Another object of the present invention is to provide an RF handpiece which  
5 includes at least one RF electrode that is capacitively coupled to a skin surface when at least a portion of the RF electrode is in contact with the skin surface.

Yet another object of the present invention is to provide an RF handpiece that provides a uniform thermal effect in tissue at a selected depth, while preventing or minimizing thermal damage to a skin surface and other non-target tissue.

10 A further object of the present invention is to provide an RF handpiece configured to reduce or eliminate the edge effects and hot spots of RF electrodes applied to skin surfaces.

Another object of the present invention is to provide an RF handpiece configured to provide an atomizing delivery of a cooling fluidic medium to the RF electrode.

15 Still another object of the present invention is to provide an RF handpiece configured to evaporatively cool the back surface of the RF electrode, and conductively cool a skin surface adjacent to a front surface of the RF electrode.

A further object of the present invention is to provide an RF handpiece configured to controllably deliver a cooling fluidic medium to the back surface of the RF  
20 electrode at substantially any orientation of the front surface of the RF electrode relative to a direction of gravity.

Yet another object of the present invention is to provide an RF handpiece that includes an RF electrode with both conductive and dielectric portions.

Another object of the present invention is to provide an RF handpiece that  
25 includes a force sensor that zeros out gravity effects created by the weight of the electrode assembly of the RF handpiece in any orientation of the front surface of the RF electrode relative to a direction of gravity.

These and other objects of the present invention are achieved in a handpiece that has a handpiece assembly. The handpiece assembly includes a handpiece housing  
30 and a cooling fluidic medium valve member. An electrode assembly is coupled to the handpiece housing. The electrode assembly has a least one RF electrode that is capacitively coupled to a skin surface when at least a portion of the RF electrode is in contact with the skin surface.

In another embodiment of the present invention a handpiece, a handpiece assembly includes a handpiece housing and a cooling fluidic medium valve member with an inlet and an outlet. An electrode assembly is removeably coupled to the handpiece housing. The electrode assembly has a least one RF electrode with a front  
5 surface and a back surface. The RF electrode is capacitively coupled to a skin surface when at least a portion of the RF electrode is in contact with the skin surface.

In another embodiment of the present invention, a handpiece includes a handpiece assembly with a handpiece housing. An insert is at least partially positionable in the handpiece housing. An RF electrode is coupled to the insert. The  
10 RF electrode has a back surface that faces the handpiece housing and an opposing front surface. A cooling fluidic medium dispensing assembly is coupled to the handpiece housing and the insert.

In another embodiment of the present invention, a handpiece includes a handpiece assembly with a handpiece housing. An insert is detachably coupled to the  
15 handpiece housing. The insert includes an RF electrode with a conductive portion and a dielectric.

In another embodiment of the present invention, a handpiece includes a handpiece assembly with a handpiece housing. An insert is detachably coupled to the handpiece housing. An RF electrode is positioned in the insert. The RF electrode  
20 includes a flex circuit.

In another embodiment of the present invention, a handpiece includes a handpiece assembly with a handpiece housing. An insert is detachably coupled to the handpiece housing. The insert includes a flex circuit and an RF electrode that with a  
25 conductive portion and a dielectric.

### **BRIEF DESCRIPTION OF THE DRAWINGS**

Figure 1 is a cross-sectional view of one embodiment of the handpiece of the present invention.

Figure 2 is an exploded view of the Figure 1 insert assembly.

30 Figure 3 is a close-up view of one embodiment of an RF electrode of the present invention.

Figure 4 is another cross-sectional view of a portion of the handpiece housing from Figure 1.

Figure 5 is a cross-sectional view of the insert from Figure 1.

### **DETAILED DESCRIPTION**

Referring now to Figure 1, one embodiment of the present invention is a handpiece 10 with a handpiece assembly 12. Handpiece assembly 12 includes a handpiece housing 14 and a cooling fluidic medium valve member 16. An electrode assembly 18 is coupled to handpiece housing 14. Electrode assembly 18 has a least one RF electrode 20 that is capacitively coupled to a skin surface when at least a portion of RF electrode 20 is in contact with the skin surface. Without limiting the scope of the present invention, RF electrode 20 can have a thickness in the range of 0.010 to 1.0 mm.

Handpiece 10 provides a more uniform thermal effect in tissue at a selected depth, while preventing or minimizing thermal damage to the skin surface and other non-target tissue. Handpiece 10 is coupled to an RF generator. RF electrode 20 can be operated either in mono-polar or bi-polar modes. Handpiece 10 is configured to reduce, or preferably eliminate edge effects and hot spots. The result is an improved aesthetic result/clinical outcome with an elimination/reduction in adverse effects and healing time.

A fluid delivery member 22 is coupled to cooling fluidic medium valve member 16. Fluid delivery member 22 and cooling fluidic medium valve member 16 collectively form a cooling fluidic medium dispensing assembly. Fluid delivery member 16 is configured to provide an atomizing delivery of a cooling fluidic medium to RF electrode 20. The atomizing delivery is a mist or fine spray. A phase transition, from liquid to gas, of the cooling fluidic medium occurs when it hits the surface of RF electrode 20. The transition from liquid to gas creates the cooling. If the transition before the cooling fluidic medium hits RF electrode 20 the cooling of RF electrode 20 will not be as effective.

In one embodiment, the cooling fluidic medium is a cryogenic spray, commercially available from Honeywell, Morristown, New Jersey. A specific example of a suitable cryogenic spray is R134A<sub>2</sub>, available from Refron, Inc., 38-18 33<sup>rd</sup> St., Long Island City, New York 11101. The use of a cryogenic cooling fluidic medium provides the capability to use a number of different types of algorithms for skin treatment. For example, the cryogenic cooling fluidic medium can be applied milliseconds before and after the delivery of RF energy to the desired tissue. This is achieved with the use of cooling fluidic medium valve member 16 coupled to a cryogen supply, including but not

limited to a compressed gas canister. In various embodiments, cooling fluidic medium valve member 16 can be coupled to a computer control system and/or manually controlled by the physician by means of a foot switch or similar device.

5 A key advantage of providing a spray, or atomization, of cryogenic cooling fluidic medium is the availability to implement rapid on and off control. Cryogenic cooling fluidic medium allows more precise temporal control of the cooling process. This is because cooling only occurs when the refrigerant is sprayed and is in an evaporative state, the latter being a very fast short-lived event. Thus, cooling ceases rapidly after the cryogenic cooling fluidic medium is stopped. The overall effect is to confer very  
10 precise time on-off control of cryogenic cooling fluidic medium.

Referring now to Figure 2, fluid delivery member 22 can be positioned in handpiece housing 14 or electrode assembly 18. Fluid delivery member 22 is configured to controllably deliver a cooling fluidic medium to a back surface 24 of RF electrode 20 and maintain back surface 24 at a desired temperature. The cooling fluidic  
15 medium evaporatively cools RF electrode 20 and maintains a substantially uniform temperature of front surface 26 of RF electrode 20. Front surface 26 can be sufficiently flexible and conformable to the skin, but still have sufficient strength and/or structure to provide good thermal coupling when pressed against the skin surface.

RF electrode 20 then conductively cools a skin surface that is adjacent to a front  
20 surface 26 of RF electrode 20. Suitable fluidic media include a variety of refrigerants such as R134A and freon. Fluid delivery member 22 is configured to controllably deliver the cooling fluidic medium to back surface 24 at substantially any orientation of front surface 26 relative to a direction of gravity. A geometry and positioning of fluid delivery member 22 are selected to provide a substantially uniform distribution of  
25 cooling fluidic medium on back surface 24. The delivery of the cooling fluidic medium can be by spray of droplets or fine mist, flooding back surface 24, and the like. Cooling occurs at the interface of the cooling fluidic medium with atmosphere, which is where evaporation occurs. If there is a thick layer of fluid on back surface 24 the heat removed from the treated skin will need to pass through the thick layer of cooling  
30 fluidic medium, increasing thermal resistance. To maximize cooling rates, it is desirable to apply a very thin layer of cooling fluidic medium. If RF electrode 20 is not horizontal, and if there is a thick layer of cooling fluidic medium, or if there are large drops of cooling fluidic medium on back surface 24, the cooling fluidic medium can run down the surface of RF electrode 20 and pool at one edge or corner, causing uneven cooling.

Therefore, it is desirable to apply a thin layer of cooling fluidic medium with a fine spray.

In various embodiments, RF electrode 20, as illustrated in Figure 3, has a conductive portion 28 and a dielectric portion 30. Conductive portion 28 can be a metal including but not limited to copper, gold, silver, aluminum and the like. Dielectric portion 30 can be made of a variety of different materials including but not limited to polyimide, and the like. Other dielectric materials include but are not limited to silicon, sapphire, diamond, zirconium-toughened alumina (ZTA), alumina and the like. Dielectric portion 30 can be positioned around at least a portion, or the entirety of a periphery of conductive portion 28. Suitable materials for a dielectric portion 30 include, but are not limited to, Teflon® and the like, silicon nitride, polysilanes, polysilazanes, polyimides, Kapton and other polymers, antenna dielectrics and other dielectric materials well known in the art. In another embodiment, RF electrode 20 is made of a composite material, including but not limited to gold-plated copper, copper-polyimide, silicon/silicon-nitride and the like.

Dielectric portion 30 creates an increased impedance to the flow of electrical current through RF electrode 20. This increased impedance causes current to travel a path straight down through conductive portion 28 to the skin surface. Electric field edge effects, caused by a concentration of current flowing out of the edges of RF electrode 20, are reduced.

Dielectric portion 30 produces a more uniform impedance through RF electrode 20 and causes a more uniform current to flow through conductive portion 28. The resulting effect minimizes or even eliminates, edge effects around the edges of RF electrode 20.

In one embodiment, conductive portion 28 adheres to dielectric portion 30 which can be substrate with a thickness, by way of example and without limitation, of about 0.001". This embodiment is similar to a standard flex circuit board material commercially available in the electronics industry. In this embodiment, dielectric portion 30 is in contact with the tissue, the skin, and conductive portion 28 is separated from the skin. The thickness of the dielectric portion 30 can be decreased by growing conductive portion 28 on dielectric portion 30 using a variety of techniques, including but not limited to, sputtering, electro deposition, chemical vapor deposition, plasma deposition and other deposition techniques known in the art. Additionally, these same processes can be used to deposit dielectric portion 30 onto conductive portion 28. In

one embodiment dielectric portion 30 is an oxide layer which can be grown on conductive portion 28. An oxide layer has a low thermal resistance and improves the cooling efficiency of the skin compared with many other dielectrics such as polymers.

Fluid delivery member 22 has an inlet 32 and an outlet 34. Outlet 34 can have a smaller cross-sectional area than a cross-sectional area of inlet 32. In one embodiment, fluid delivery member 22 is a nozzle 36.

Cooling fluidic medium valve member 16 can be configured to provide a pulsed delivery of the cooling fluidic medium. Pulsing the delivery of cooling fluidic medium is a simple way to control the rate of cooling fluidic medium application. In one embodiment, cooling fluidic medium valve member 16 is a solenoid valve. An example of a suitable solenoid valve is a solenoid pinch valve manufactured by the N-Research Corporation, West Caldwell, NJ. If the fluid is pressurized, then opening of the valve results in fluid flow. If the fluid is maintained at a constant pressure, then the flow rate is constant and a simple open/close solenoid valve can be used, the effective flow rate being determined by the pulse duty cycle. A higher duty cycle, close to 100% increases cooling, while a lower duty cycle, closer to 0%, reduces cooling. The duty cycle can be achieved by turning on the valve for a short duration of time at a set frequency. The duration of the open time can be 1 to 50 milliseconds or longer. The frequency of pulsing can be 1 to 50 Hz or faster.

Alternatively, cooling fluidic medium flow rate can be controlled by a metering valve or controllable-rate pump such as a peristaltic pump. One advantage of pulsing is that it is easy to control using simple electronics and control algorithms.

Electrode assembly 18 is sufficiently sealed so that the cooling fluidic medium does not leak from back surface 24 onto a skin surface in contact with a front surface of RF electrode 20. This helps provide an even energy delivery through the skin surface. In one embodiment, electrode assembly 18, and more specifically RF electrode 20, has a geometry that creates a reservoir at back surface 24 to hold and gather cooling fluidic medium that has collected at back surface 24. Back surface 24 can be formed with "hospital corners" to create this reservoir. Optionally, electrode assembly 18 includes a vent 38 that permits vaporized cooling fluidic medium to escape from electrode assembly 18. This reduces the chance of cooling fluidic medium collecting at back surface 24. This can occur when cooling fluidic medium is delivered to back surface 24 in vapor form and then, following cooling of back surface 24, the vapor condenses to a liquid.

Vent 38 prevents pressure from building up in electrode assembly 18. Vent 38 can be a pressure relief valve that is vented to the atmosphere or a vent line. When the cooling fluidic medium comes into contact with RF electrode 20 and evaporates, the resulting gas pressurizes the inside of electrode assembly 18. This can cause RF electrode 20 to partially inflate and bow out from front surface 26. The inflated RF electrode 20 can enhance the thermal contact with the skin and also result in some degree of conformance of RF electrode 20 to the skin surface. An electronic controller can be provided. The electronic controller sends a signal to open vent 38 when a programmed pressure has been reached.

Various leads 40 are coupled to RF electrode 20. One or more thermal sensors 42 are coupled to RF electrode. Suitable thermal sensors 42 include but are not limited to thermocouples, thermistors, infrared photo-emitters and a thermally sensitive diode. In one embodiment, a thermal sensor 42 is positioned at each corner of RF electrode 20. A sufficient number of thermal sensors 42 are provided in order to acquire sufficient thermal data of the skin surface. Thermal sensors 42 are electrically isolated from RF electrode 20.

Thermal sensors 42 measure temperature and can provide feedback for monitoring temperature of RF electrode 20 and/or the tissue during treatment. Thermal sensors 42 can be thermistors, thermocouples, thermally sensitive diodes, capacitors, inductors or other devices for measuring temperature. Preferably, thermal sensors 42 provide electronic feedback to a microprocessor of the an RF generator coupled to RF electrode 20 in order to facilitate control of the treatment.

The measurements from thermal sensors 42 can be used to help control the rate of application of cooling fluidic medium. For example, the cooling control algorithm can be used to apply cooling fluidic medium to RF electrode 20 at a high flow rate until the temperature fell below a target temperature, and then slow down or stop. A PID, or proportional-integral-differential, algorithm can be used to precisely control RF electrode 20 temperature to a predetermined value.

Thermal sensors 42 can be positioned placed on back surface 24 of RF electrode 20 away from the tissue. This configuration is preferable ideal for controlling the temperature of the RF electrode 20. Alternatively, thermal sensors 42 can be positioned on front surface 26 of RF electrode 10 in direct contact with the tissue. This embodiment can be more suitable for monitoring tissue temperature. Algorithms are utilized with thermal sensors 42 to calculate a temperature profile of the treated tissue.

Thermal sensors 42 can be used to develop a temperature profile of the skin which is then used for process control purposes to assure that the proper amounts of heating and cooling are delivered to achieve a desired elevated deep tissue temperature while maintaining skin tissue layers below a threshold temperature and avoid thermal injury.

5 The physician can use the measured temperature profile to assure that he stays within the boundary of an ideal/average profile for a given type of treatment. Thermal sensors 42 can be used for additional purposes. When the temperature of thermal sensors 42 is monitored it is possible to detect when RF electrode 20 is in contact with the skin surface. This can be achieved by detecting a direct change in temperature

10 when skin contact is made or examining the rate of change of temperature which is affected by contact with the skin. Similarly, if there is more than one thermal sensor 42, the thermal sensors 42 can be used to detect whether a portion of RF electrode 20 is lifted or out of contact with skin. This can be important because the current density (amperes per unit area) delivered to the skin can vary if the contact area changes. In

15 particular, if part of the surface of RF electrode 20 is not in contact with the skin, the resulting current density is higher than expected.

Referring now to Figure 4, a force sensor 44 is also coupled to electrode assembly 18. Force sensor 44 detects an amount of force applied by electrode assembly 18, via the physician, against an applied skin surface. Force sensor 44 zeros

20 out gravity effects of the weight of electrode assembly 18 in any orientation of front surface 26 of RF electrode 20 relative to a direction of gravity. Additionally, force sensor 44 provides an indication when RF electrode 20 is in contact with a skin surface. Force sensor 44 also provides a signal indicating that a force applied by RF electrode 20 to a contacted skin surface is, (i) below a minimum threshold or (ii) above a maximum

25 threshold.

An activation button 46 is used in conjunction with the force sensor. Just prior to activating Rf electrode 20, the physician holds handpiece 10 in position just off the surface of the skin. The orientation of handpiece 10 can be any angle relative to the angle of gravity. To arm handpiece 10, the physician can press activation button 46

30 which tares force sensor 44, by setting it to read zero. This cancels the force due to gravity in that particular treatment orientation. This method allows consistent force application of RF electrode 20 to the skin surface regardless of the angle of handpiece 10 relative to the direction of gravity.

RF electrode 20 can be a flex circuit, which can include trace components. Additionally, thermal sensor 42 and force sensor 44 can be part of the flex circuit. Further, the flex circuit can include a dielectric that forms a part of RF electrode 20.

Electrode assembly 18 can be moveably positioned within handpiece housing 12.

5 In one embodiment, electrode assembly 18 is slideably moveable along a longitudinal axis of handpiece housing 12. Electrode assembly 18 can be rotatably mounted in handpiece housing 12. Additionally, RF electrode 20 can be rotatably positioned in electrode assembly 18. Electrode assembly 18 can be removably coupled to handpiece housing 12 as a disposable or non-disposable insert 52, see Figure 5. For purposes of  
10 this disclosure, electrode assembly 18 is the same as insert 52. Once movably mounted to handpiece housing 12, insert 52 can be coupled to handpiece housing 12 via force sensor 44. Force sensor 44 can be of the type that is capable of measuring both compressive and tensile forces. In other embodiments, , force sensor 44 only measures compressive forces, or only measures tensile forces.

15 Insert 52 can be spring-loaded with a spring 48. In one embodiment, spring 48 biases RF electrode 20 in a direction toward handpiece housing 12. This pre-loads force sensor 44 and keeps insert 52 pressed against force sensor 44. The pre-load force is tared when activation button 46 is pressed just prior to application of RF electrode 20 to the skin surface.

20 A shroud 50 is optionally coupled to handpiece 10. Shroud 50 serves to keep the user from touching insert 52 during use which can cause erroneous force readings.

A non-volatile memory 54 can be included with insert 52. Additionally, non-volatile memory can be included with handpiece housing 12. Non-volatile memory 54 can be an EPROM and the like. Additionally, a second non-volatile memory 56 can be  
25 included in handpiece housing 12 for purposes of storing handpiece 10 information such as but not limited to, handpiece model number or version, handpiece software version, number of RF applications that handpiece 10 has delivered, expiration date and manufacture date. Handpiece housing 12 can also contain a microprocessor 58 for purposes of acquiring and analyzing data from various sensors on handpiece housing 12  
30 or insert 52 including but not limited to thermal sensors 42 , force sensors 44, fluid pressure gauges, switches, buttons and the like. Microprocessor 58 can also control components on handpiece 10 including but not limited to lights, LEDs, valves, pumps or other electronic components. Microprocessor 58 can also communicate data to a microprocessor of the RF generator.

Non-volatile memory 54 can store a variety of data that can facilitate control and operation of handpiece 10 and its associated system including but not limited to, (i) controlling the amount of current delivered by RF electrode 20, (ii) controlling the duty cycle of the fluid delivery member 22, (iii) controlling the energy delivery duration time of the RF electrode 20, (iv) controlling the temperature of RF electrode 20 relative to a target temperature, (v) providing a maximum number of firings of RF electrode 20, (vi) providing a maximum allowed voltage that is deliverable by RF electrode 20, (vii) providing a history of RF electrode 20 use, (viii) providing a controllable duty cycle to fluid delivery member 22 for the delivery of the cooling fluidic medium to back surface 24 of RF electrode 20, (ix) providing a controllable delivery rate of cooling fluidic medium delivered from fluid delivery member 22 to back surface 24, and the like.

Handpiece 10 can be used to deliver thermal energy to modify tissue including, but not limited to, collagen containing tissue, in the epidermal, dermal and subcutaneous tissue layers, including adipose tissue. The modification of the tissue includes modifying a physical feature of the tissue, a structure of the tissue or a physical property of the tissue. The modification can be achieved by delivering sufficient energy to cause collagen shrinkage, and/or a wound healing response including the deposition of new or nascent collagen.

Handpiece 10 can be utilized for performing a number of treatments of the skin and underlying tissue including but not limited to, (i) dermal remodeling and tightening, (ii) wrinkle reduction, (iii) elastosis reduction, (iv) sebaceous gland removal/deactivation, (v) hair follicle removal, (vi) adipose tissue remodeling/removal, (vii) spider vein removal, and the like.

In various embodiments, handpiece 10 can be utilized in a variety of treatment processes, including but not limited to, (i) pre-cooling, before the delivery of energy to the tissue has begun, (ii) an on phase or energy delivery phase in conjunction with cooling and (iii) post cooling after the delivery of energy to tissue has stopped.

Handpiece 10 can be used to pre-cool the surface layers of the target tissue so that when RF electrode 20 is in contact with the tissue, or prior to turning on the RF energy source, the superficial layers of the target tissue are already cooled. When RF energy source is turned on or delivery of RF to the tissue otherwise begins, resulting in heating of the tissues, the tissue that has been cooled is protected from thermal effects including thermal damage. The tissue that has not been cooled will warm up to therapeutic temperatures resulting in the desired therapeutic effect.

Pre-cooling gives time for the thermal effects of cooling to propagate down into the tissue. More specifically, pre-cooling allows the achievement of a desired tissue depth thermal profile, with a minimum desired temperature being achieved at a selectable depth. The amount or duration of pre-cooling can be used to select the  
5 depth of the protected zone of untreated tissue. Longer durations of pre-cooling produce a deeper protected zone and hence a deeper level in tissue for the start of the treatment zone. The opposite is true for shorter periods of pre-cooling. The temperature of front surface 26 of RF electrode 20 also affects the temperature profile. The colder the temperature of front surface 26, the faster and deeper the cooling, and  
10 vice versa.

Post-cooling can be important because it prevents and/or reduces heat delivered to the deeper layers from conducting upward and heating the more superficial layers possibly to therapeutic or damaging temperature range even though external energy delivery to the tissue has ceased. In order to prevent this and related thermal  
15 phenomena, it can be desirable to maintain cooling of the treatment surface for a period of time after application of the RF energy has ceased. In various embodiments, varying amounts of post cooling can be combined with real-time cooling and/or pre-cooling.

In various embodiments, handpiece 10 can be used in a varied number of pulse  
20 on-off type cooling sequences and algorithms may be employed. In one embodiment, the treatment algorithm provides for pre-cooling of the tissue by starting a spray of cryogenic cooling fluidic medium, followed by a short pulse of RF energy into the tissue. In this embodiment, the spray of cryogenic cooling fluidic medium continues while the RF energy is delivered, and is stopping shortly thereafter, e.g. on the order of  
25 milliseconds. This or another treatment sequence can be repeated again. Thus in various embodiments, the treatment sequence can include a pulsed sequence of cooling on, heat, cooling off, cooling on, heat, cool off, and with cooling and heating durations on orders of tens of milliseconds. In these embodiments, every time the surface of the tissue of the skin is cooled, heat is removed from the skin surface. Cryogenic cooling  
30 fluidic medium spray duration, and intervals between sprays, can be in the tens of milliseconds ranges, which allows surface cooling while still delivering the desired thermal effect into the deeper target tissue.

In various embodiments, the target tissue zone for therapy, also called therapeutic zone or thermal effect zone, can be at a tissue depth from approximately

100  $\mu\text{m}$  beneath the surface of the skin down to as deep as 10 millimeters, depending upon the type of treatment. For treatments involving collagen contraction, it can be desirable to cool both the epidermis and the superficial layers of the dermis of the skin that lies beneath the epidermis, to a cooled depth range between 100  $\mu\text{m}$  two  
5 millimeters. Different treatment algorithms can incorporate different amounts of pre-cooling, heating and post cooling phases in order to produce a desired tissue effect at a desired depth.

Various duty cycles, on and off times, of cooling and heating are utilized depending on the type of treatment. The cooling and heating duty cycles can be  
10 controlled and dynamically varied by an electronic control system known in the art. Specifically the control system can be used to control cooling fluidic medium valve member 16 and the RF power source.

The foregoing description of a preferred embodiment of the invention has been presented for purposes of illustration and description. It is not intended to be  
15 exhaustive or to limit the invention to the precise forms disclosed. Obviously, many modifications and variations will be apparent to practitioners skilled in this art. It is intended that the scope of the invention be defined by the following claims and their equivalents.

What is claimed is:

## CLAIMS

1           1.     An RF device, comprising:  
2           a device assembly including a housing and a cooling fluidic medium valve  
3 member; and  
4           an electrode assembly coupled to the housing, the electrode assembly including a  
5 least one RF electrode that is capacitively coupled to a skin surface when at least a portion of the  
6 RF electrode is in contact with the skin surface.  
7

1           2.     The RF device of claim 1, further comprising:  
2           a fluid delivery member coupled to the cooling fluidic medium valve member, wherein  
3 the fluid delivery member is configured to provide an atomizing delivery of a cooling fluidic  
4 medium to the RF electrode.

1           3.     The RF device of claim 2, wherein the fluid delivery member is coupled to a RF  
2 electrode housing .

1           4.     The RF device of claim 2, wherein the fluid delivery member is positioned in the  
2 electrode assembly.

1           5.     The RF device of claim 2, wherein the fluid delivery member includes a nozzle.

1           6.     The RF device of claim 2, wherein the fluid delivery member is configured to  
2 deliver a controllable amount of cooling fluidic medium to the RF electrode.

1           7.     The RF device of claim 2, wherein the fluid delivery member is configured to  
2 controllably deliver the cooling fluidic medium to a back surface of the RF electrode.

1           8.     The RF device of claim 2, wherein the fluid delivery member is configured to  
2 controllably deliver fluid to a backside of the RF electrode to evaporatively cool the RF electrode  
3 and conductively cool a skin surface in contact with the front side of the RF electrode.

1           9.     The RF device of claim 2, wherein the fluid delivery member is configured to  
2 controllably deliver a cooling fluidic medium to a back surface of the RF electrode at

3 substantially any orientation of the front surface of the RF electrode relative to a direction of  
4 gravity.

1 10. The RF device of claim 1, wherein the electrode assembly is sufficiently sealed to  
2 minimize flow of a cooling fluidic medium from a back surface of the RF electrode to a skin  
3 surface in contact with a front surface of the RF electrode.

1 11. The RF device of claim 1, wherein the electrode assembly includes a vent.

1 12. The RF device of claim 1, wherein the cooling fluidic medium valve member is  
2 configured to provide a pulsed delivery of a cooling fluidic medium.

1 13. The RF device of claim 1, wherein the cooling fluidic medium valve member  
2 includes a solenoid valve.

1 14. The RF device of claim 1, wherein the RF electrode includes a conductive portion  
2 and a dielectric portion.

1 15. The RF device of claim 14, wherein the conductive portion includes metal.

1 16. The RF device of claim 14, wherein the conductive portion includes copper.

1 17. The RF device of claim 14, wherein the dielectric portion includes polyimide.

1 18. The RF device of claim 14, wherein the RF electrode includes a copper polyimide  
2 composite material.

1 19. The RF device of claim 1, further comprising:  
2 leads coupled to the RF electrode.

1 20. The RF device of claim 1, further comprising:  
2 a flex circuit coupled to the RF electrode.

1 21. The RF device of claim 20, wherein the flex circuit is configured to isolate flow  
2 of a cooling fluidic medium from a back surface of the RF electrode to a front surface of the RF  
3 electrode.

1 22. The RF device of claim 20, wherein the flex circuit is configured to create a  
2 reservoir for a cooling fluidic medium that gathers at a back surface of the RF electrode.

1           23.     The RF device of claim 20, wherein the flex circuit includes trace components.

1           24.     The RF device of claim 20, further comprising:

2           a force sensor coupled to the dielectric.

1           25.     The RF device of claim 20, wherein the flex circuit includes a thermal sensor.

1           26.     The RF device of claim 20, wherein the flex circuit includes a dielectric that  
2 forms a portion of the RF electrode.

1           27.     The RF device of claim 1, further comprising:

2           a force sensor coupled to the RF electrode.

1           28.     The RF device of claim 27, wherein the force sensor is configured to detect an  
2 amount of force applied by the RF electrode against a surface.

1           29.     The RF device of claim 27, wherein the force sensor is configured to zero out  
2 gravity effects of the weight of the electrode assembly.

1           30.     The RF device of claim 27, wherein the force sensor is configured to zero out  
2 gravity effects of the weight of the electrode assembly in any orientation of a front surface of the  
3 RF electrode relative to a direction of gravity.

1           31.     The RF device of claim 27, wherein the force sensor is configured to provide an  
2 indication of RF electrode contact with a skin surface.

1           32.     The RF device of claim 27, wherein the force sensor is configured to provide a  
2 signal indicating that a force applied by the RF electrode to a contacted skin surface is below a  
3 minimum threshold.

1           33.     The RF device of claim 27, wherein the force sensor is configured to provide a  
2 signal indicating that a force applied by the RF electrode to a contacted skin surface is above a  
3 maximum threshold.

1           34.     The RF device of claim 27, further comprising:

2           a tare button coupled to the force sensor.

1           35.     The RF device of claim 1, further comprising:

2 a spring coupled to the RF electrode.

1 36. The RF device of claim 35, wherein the spring is pre-loaded.

1 37. The RF device of claim 35, wherein the spring is configured to bias the RF  
2 electrode in a direction toward an RF electrode housing.

1 38. The RF device of claim 1, further comprising:  
2 a shroud coupled to the electrode assembly.

1 39. The RF device of claim 1, further comprising:  
2 a RF electrode identifier.

1 40. The RF device of claim 1, wherein the RF electrode includes a conductive portion  
2 with a dielectric positioned around at least a portion of a periphery of the conductive portion.

1 41. The RF device of claim 1, wherein the RF electrode includes a conductive portion  
2 with a dielectric positioned around an entirety of a periphery of the conductive portion.

1 42. The RF device of claim 1, wherein the electrode assembly includes a cooling  
2 fluidic medium channel with an inlet and an outlet.

1 43. The RF device of claim 42, wherein the outlet of the cooling fluidic medium  
2 channel has a smaller cross-sectional area than a cross-sectional area of the inlet.

1 44. The RF device of claim 1, wherein the electrode assembly is moveable within at  
2 least a portion of an RF electrode housing.

1 45. The RF device of claim 1, wherein the electrode assembly is slideably moveable  
2 within at least a portion of an RF electrode housing.

1 46. The RF device of claim 1, wherein the electrode assembly is rotatably moveable  
2 relative to an RF electrode housing.

1 47. The RF device of claim 1, wherein the RF electrode is rotatably positioned in the  
2 electrode assembly.

1 48. The RF device of claim 1, wherein the electrode assembly is coupled to The RF  
2 device housing in a stationary position.

1           49.    An RF device, comprising:  
2           a device assembly including a housing and a cooling fluidic medium valve member with  
3 an inlet and an outlet; and  
4           an electrode assembly removably coupled to the device assembly, the electrode assembly  
5 including a least one RF electrode with a front surface and a back surface, wherein the RF  
6 electrode is capacitively coupled to a skin surface when at least a portion of the RF electrode is  
7 in contact with the skin surface.

1           50.    The RF device of claim 49, further comprising:  
2           a fluid delivery member coupled to the cooling fluidic medium valve member, wherein  
3 the fluid delivery member is configured to provide an atomizing delivery of a cooling fluidic  
4 medium to the RF electrode.

1           51.    The RF device of claim 50, wherein the fluid delivery member is positioned in  
2 The RF device housing.

1           52.    The RF device of claim 50, wherein the fluid delivery member is positioned in the  
2 electrode assembly.

1           53.    The RF device of claim 50, wherein the fluid delivery member includes a nozzle.

1           54.    The RF device of claim 50, wherein the fluid delivery member is configured to  
2 deliver a controllable amount of cooling fluidic medium to the RF electrode.

1           55.    The RF device of claim 50, wherein the fluid delivery member is configured to  
2 controllably deliver the cooling fluidic medium to the back surface of the RF electrode.

1           56.    The RF device of claim 50, wherein the fluid delivery member is configured to  
2 controllably deliver fluid to a backside of the RF electrode to evaporatively cool the RF electrode  
3 and conductively cool a skin surface in contact with the front side of the RF electrode.

1           57.    The RF device of claim 50, wherein the fluid delivery member is configured to  
2 controllably deliver a cooling fluidic medium to the back surface of the RF electrode at  
3 substantially any orientation of the front surface of the RF electrode relative to a direction of  
4 gravity.

1           58.     The RF device of claim 49, wherein the electrode assembly is sufficiently sealed  
2 to minimize flow of a cooling fluidic medium from the back surface of the RF electrode to a skin  
3 surface in contact with the front surface of the RF electrode.

1           59.     The RF device of claim 49, wherein the electrode assembly includes a vent.

1           60.     The RF device of claim 49, wherein the cooling fluidic medium valve member is  
2 configured to provide a pulsed delivery of a cooling fluidic medium.

1           61.     The RF device of claim 49, wherein the cooling fluidic medium valve member  
2 includes a solenoid valve.

1           62.     The RF device of claim 50, wherein the fluid delivery member is configured to  
2 deliver a sufficient amount of cooling fluidic medium to controllably maintain the back surface  
3 of the RF electrode at a desired temperature.

1           63.     The RF device of claim 50, wherein the fluid delivery member is configured to  
2 controllably deliver a sufficient of cooling fluidic medium to the back surface of the RF  
3 electrode and maintain a substantially uniform temperature of the front surface of the RF  
4 electrode.

1           64.     The RF device of claim 49, further comprising:  
2 a thermal sensor coupled to the RF electrode.

1           65.     The RF device of claim 49, further comprising:  
2 a plurality of thermal sensors coupled to the RF electrode.

1           66.     The RF device of claim 49, further comprising:  
2 four thermal sensors coupled to the RF electrode.

1           67.     The RF device of claim 64, wherein the thermal sensor is positioned at the back  
2 surface of the RF electrode.

1           68.     The RF device of claim 64, wherein the thermal sensor is electrically isolated  
2 from the RF electrode.

1           69.     The RF device of claim 64, wherein the thermal sensor is selected from a  
2 thermocouple, thermistor, infrared photo-emitter and a thermally sensitive diode.

1           70.     The RF device of claim 49, wherein the outlet of the cooling fluidic medium  
2 valve member is distanced from the back surface of the RF electrode.

1           71.     The RF device of claim 49, wherein a geometry and a positioning of the fluid  
2 delivery member are selected to provide a substantially uniform distribution of fluid on the back  
3 surface of the RF electrode.

1           72.     The RF device of claim 49, wherein the RF electrode has a thickness in the range  
2 of 0.010 to 1.0 mm.

1           73.     An RF device, comprising:  
2 a device assembly including a housing;  
3 a support coupled to the housing;  
4 an RF electrode coupled to the support, the RF electrode including a back surface facing  
5 the RF electrode and an opposing front surface; and  
6 a cooling fluidic medium dispensing assembly coupled to assembly and the substrate.

1           74.     The RF device of claim 73, wherein the cooling fluidic medium dispensing  
2 assembly includes a fluid delivery member coupled to a cooling fluidic medium valve member.

1           75.     The RF device of claim 74, wherein the cooling fluidic medium valve member is  
2 positioned in the device assembly.

1           76.     The RF device of claim 74, wherein the cooling fluidic medium valve member is  
2 positioned in the support.

1           77.     The RF device of claim 74, wherein the fluid delivery member is positioned in the  
2 device assembly.

1           78.     The RF device of claim 74, wherein the fluid delivery member is positioned in  
2 support.

1           79.     The RF device of claim 74, wherein the fluid delivery member includes a nozzle.

1           80.     The RF device of claim 74, wherein the fluid delivery member is configured to  
2 deliver a controllable amount of cooling fluidic medium to the RF electrode.

1           81.     The RF device of claim 74, wherein the fluid delivery member is configured to  
2 controllably deliver a cooling fluidic medium to the back surface of the RF electrode.

1           82.     The RF device of claim 74, wherein the fluid delivery member is configured to  
2 controllably deliver fluid to a backside of the RF electrode to evaporatively cool the RF electrode  
3 and conductively cool a skin surface in contact with the front side of the RF electrode.

1           83.     The RF device of claim 74, wherein the fluid delivery member is configured to  
2 controllably deliver a cooling fluidic medium to the back surface of the RF electrode at  
3 substantially any orientation of the front surface of the RF electrode relative to a direction of  
4 gravity.

1           84.     The RF device of claim 74, wherein the RF electrode is sufficiently sealed to  
2 minimize flow of a cooling fluidic medium from the back surface of the RF electrode to a skin  
3 surface in contact with the front surface of the RF electrode.

1           85.     The RF device of claim 53, wherein the support includes a vent.

1           86.     The RF device of claim 74, wherein the cooling fluidic medium valve member is  
2 configured to provide a pulsed delivery of a cooling fluidic medium.

1           87.     The RF device of claim 74, wherein the cooling fluidic medium valve member  
2 includes a solenoid valve.

1           88.     The RF device of claim 73, wherein the front surface of the RF electrode is  
2 configured to conductively cool a skin surface in contact with the front surface of the RF  
3 electrode at substantially any orientation of the front surface of the RF electrode relative to a  
4 direction of gravity.

1           89.     The RF device of claim 74, wherein the front surface of the RF electrode and the  
2 cooling fluidic medium delivery member are configured to conductively cool a skin surface in  
3 contact with the front surface of the RF electrode at substantially any orientation of the front  
4 surface of the RF electrode relative to a direction of gravity.

1           90.     The RF device of claim 73, wherein the RF electrode includes a conductive  
2 portion and a dielectric.

1           91.     The RF device of claim 73, wherein the RF electrode includes a conductive  
2 portion with a dielectric positioned around at least a portion of a periphery of the conductive  
3 portion.

1           92.     The RF device of claim 73, wherein the RF electrode includes a conductive  
2 portion with a dielectric positioned around an entirety of a periphery of the conductive portion.

1           93.     The RF device of claim 73, wherein the support is removably coupled to the  
2 device assembly.

1           94.     The RF device of claim 93, further comprising:  
2 a non-volatile memory coupled to the support.

1           95.     The RF device of claim 94, wherein the non-volatile memory is an EPROM.

1           96.     The RF device of claim 73, further comprising:  
2 a non-volatile memory coupled to support.

1           97.     The RF device of claim 96, wherein the non-volatile memory is an EPROM.

1           98.     The RF device of claim 73, wherein The RF device housing includes a  
2 microprocessor.

1           99.     The RF device of claim 94, wherein the non-volatile memory provides control of  
2 current delivered to the RF electrode.

1           100.    The RF device of claim 94, wherein the non-volatile memory provides control of  
2 duty cycle of the cooling fluidic medium delivery member.

1           101.    The RF device of claim 94, wherein the non-volatile memory provides control of  
2 energy delivery duration time from the RF electrode.

1           102.    The RF device of claim 94, wherein the non-volatile memory controls the  
2 temperature of the front surface of the RF electrode relative to a target temperature.

1           103.    The RF device of claim 94, wherein the non-volatile memory provides a  
2 maximum number of firings of the RF electrode.

1           104.    The RF device of claim 94, wherein the non-volatile memory provides a  
2 maximum allowed voltage deliverable by the RF electrode.

1           105.    The RF device of claim 94, wherein the non-volatile memory provides a history  
2 of RF electrode use.

1           106.    The RF device of claim 94, wherein the non-volatile memory is configured to  
2 provide a controllable duty cycle to the cooling fluidic medium delivery member for the delivery  
3 of cooling fluidic medium to the back surface of the RF electrode.

1           107.    The RF device of claim 94, wherein the non-volatile memory is configured to  
2 provide a controllable delivery rate of cooling fluidic medium delivered from the cooling fluidic  
3 medium delivery member to the back surface of the RF electrode.

1           108.    The RF device of claim 74, wherein the RF electrode and the fluid delivery  
2 member are configured to provide a uniform heat removal from the front surface of the RF  
3 electrode when the front surface of the RF electrode is applied to a skin surface.

1           109.    The RF device of claim 74, wherein the RF electrode and the fluid delivery  
2 member are configured to provide a uniform heat removal from that portion of the front surface  
3 of the RF electrode applied to a skin surface.

1           110.    The RF device of claim 74, wherein the RF electrode and the fluid delivery  
2 member are configured to provide a uniform heat removal from that portion of the front surface  
3 of the RF electrode applied to a skin surface at substantially any orientation of the front surface  
4 of the RF electrode relative to a direction of gravity.

1           111.    The RF device of claim 74, wherein the RF electrode and the fluid delivery  
2 member are configured to conductively cool a skin surface in contact with the front surface  
3 of the RF electrode

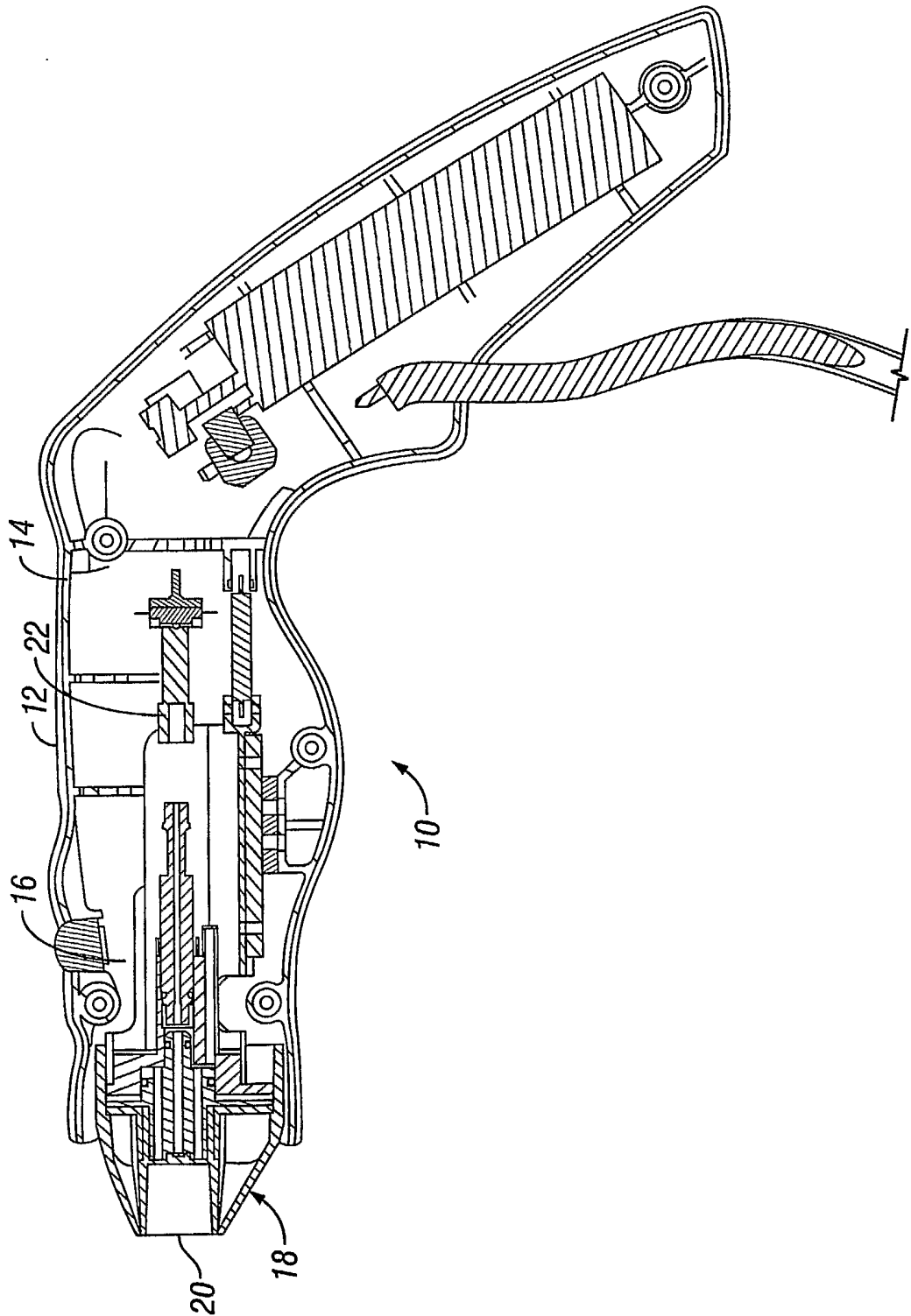

FIG. 1

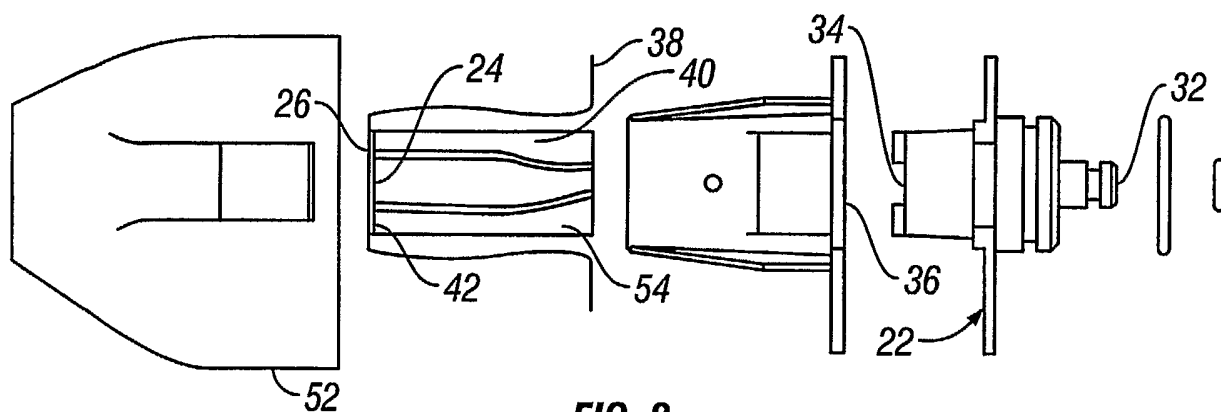

FIG. 2

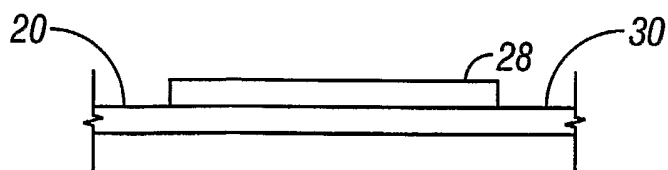

FIG. 3

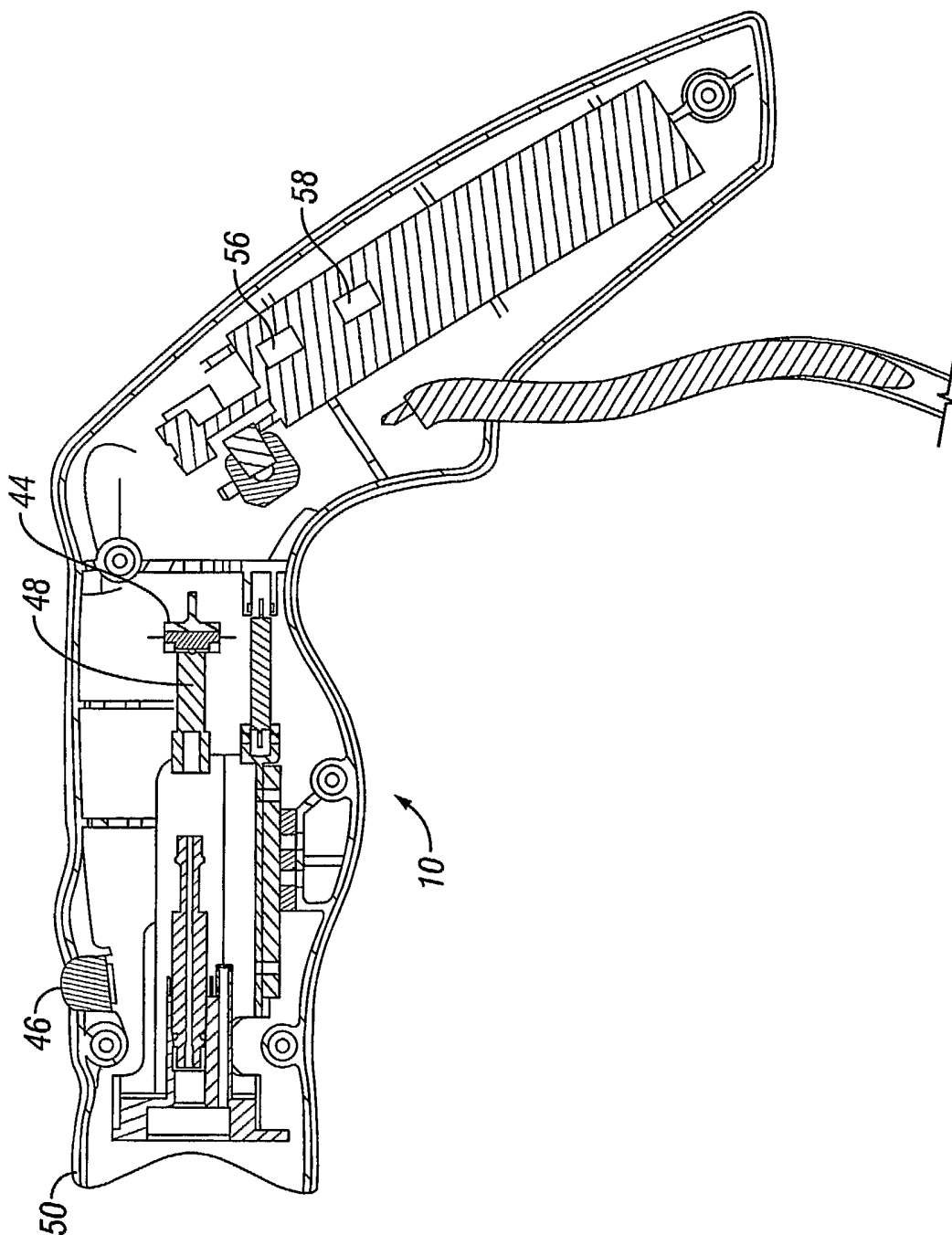

FIG. 4

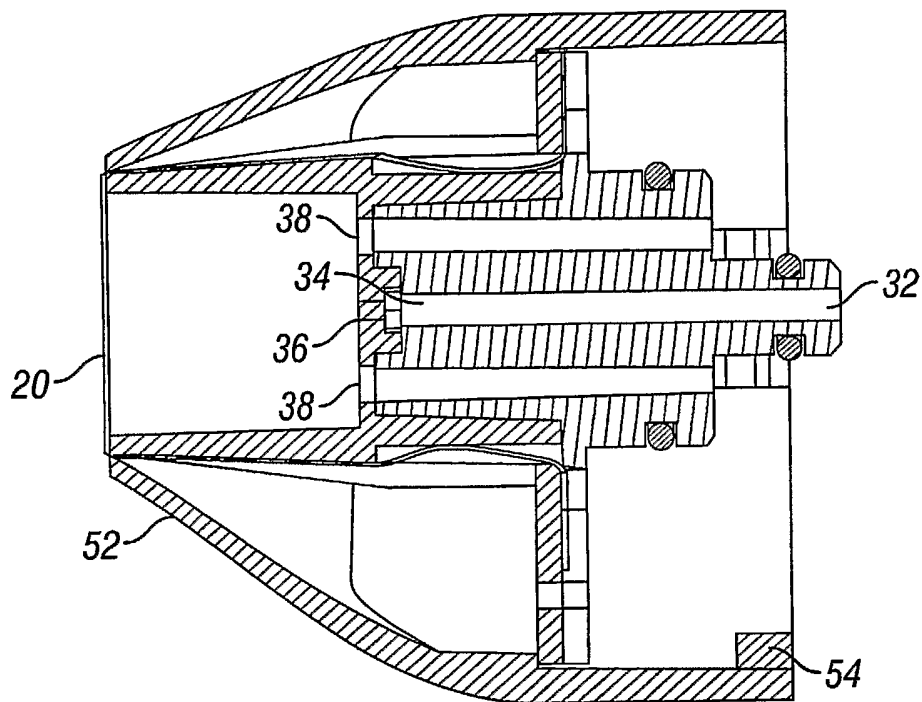

FIG. 5

## INTERNATIONAL SEARCH REPORT

International Application No

PL, JS 03/03507

## A. CLASSIFICATION OF SUBJECT MATTER

IPC 7 A61B18/14

According to International Patent Classification (IPC) or to both national classification and IPC

## B. FIELDS SEARCHED

Minimum documentation searched (classification system followed by classification symbols)

IPC 7 A61B

Documentation searched other than minimum documentation to the extent that such documents are included in the fields searched

Electronic data base consulted during the international search (name of data base and, where practical, search terms used)

EPO-Internal, PAJ, WPI Data

## C. DOCUMENTS CONSIDERED TO BE RELEVANT

Category °	Citation of document, with indication, where appropriate, of the relevant passages	Relevant to claim No.
X	EP 1 158 919 A (THERMAGE INC) 5 December 2001 (2001-12-05) cited in the application the whole document ---	1-111
X	WO 00 53113 A (STERN ROGER ; THERMAGE INC (US)) 14 September 2000 (2000-09-14) cited in the application the whole document ---	1-111
A	US 6 228 078 B1 (EGGERS PHILIP E ET AL) 8 May 2001 (2001-05-08) the whole document ---	1-111
A	US 5 948 011 A (KNOWLTON EDWARD W) 7 September 1999 (1999-09-07) abstract ---	1-111
	-/--	

 Further documents are listed in the continuation of box C. Patent family members are listed in annex.

° Special categories of cited documents :

"A" document defining the general state of the art which is not considered to be of particular relevance

"E" earlier document but published on or after the international filing date

"L" document which may throw doubts on priority claim(s) or which is cited to establish the publication date of another citation or other special reason (as specified)

"O" document referring to an oral disclosure, use, exhibition or other means

"P" document published prior to the international filing date but later than the priority date claimed

"T" later document published after the international filing date or priority date and not in conflict with the application but cited to understand the principle or theory underlying the invention

"X" document of particular relevance; the claimed invention cannot be considered novel or cannot be considered to involve an inventive step when the document is taken alone

"Y" document of particular relevance; the claimed invention cannot be considered to involve an inventive step when the document is combined with one or more other such documents, such combination being obvious to a person skilled in the art.

"&" document member of the same patent family

Date of the actual completion of the international search

26 May 2003

Date of mailing of the international search report

06/06/2003

Name and mailing address of the ISA

European Patent Office, P.B. 5818 Patentlaan 2  
NL - 2280 HV Rijswijk  
Tel. (+31-70) 340-2040, Tx. 31 651 epo nl,  
Fax: (+31-70) 340-3016

Authorized officer

Papone, F

## INTERNATIONAL SEARCH REPORT

International Application No

PCT/JS 03/03507

## C.(Continuation) DOCUMENTS CONSIDERED TO BE RELEVANT

Category *	Citation of document, with indication, where appropriate, of the relevant passages	Relevant to claim No.
A	WO 01 00269 A (KNOWLTON EDWARD W ;THERMAGE INC (US)) 4 January 2001 (2001-01-04) abstract	1-111
A	WO 99 08614 A (CLAUDE JOHN P ;DO PAUL (US); INGLE FRANK (US); MOSEL BRIAN J (US);) 25 February 1999 (1999-02-25)	

INTERNATIONAL SEARCH REPORT  
information on patent family members

International Application No  
PCT/US 03/03507

Patent document cited in search report	Publication date	Patent family member(s)	Publication date	
EP 1158919	A	05-12-2001	AU 3741500 A	28-09-2000
			CA 2364098 A1	14-09-2000
			EP 1158919 A1	05-12-2001
			JP 2002537939 A1	12-11-2002
			WO 0053113 A1	14-09-2000
			US 2002151887 A1	17-10-2002
			US 2002156471 A1	24-10-2002
			US 6413255 B1	02-07-2002
WO 0053113	A	14-09-2000	AU 3741500 A	28-09-2000
			CA 2364098 A1	14-09-2000
			EP 1158919 A1	05-12-2001
			JP 2002537939 A	12-11-2002
			WO 0053113 A1	14-09-2000
			US 2002151887 A1	17-10-2002
			US 2002156471 A1	24-10-2002
			US 6413255 B1	02-07-2002
US 6228078	B1	08-05-2001	US 6024733 A	15-02-2000
			AU 1464099 A	15-06-1999
			EP 1041933 A1	11-10-2000
			JP 2001523513 T	27-11-2001
			WO 9926546 A1	03-06-1999
			US 6264652 B1	24-07-2001
			US 6309387 B1	30-10-2001
			US 2002095152 A1	18-07-2002
			US 2002193789 A1	19-12-2002
			US 6461350 B1	08-10-2002
			US 6117109 A	12-09-2000
			US 6228082 B1	08-05-2001
			US 6461354 B1	08-10-2002
			US 2003084907 A1	08-05-2003
			US 2001029373 A1	11-10-2001
			US 2001020167 A1	06-09-2001
			US 2001049522 A1	06-12-2001
			US 6210402 B1	03-04-2001
US 5948011	A	07-09-1999	US 5755753 A	26-05-1998
			US 6311090 B1	30-10-2001
			US 6453202 B1	17-09-2002
			AU 5789396 A	21-11-1996
			EP 0957791 A1	24-11-1999
			JP 11504828 T	11-05-1999
			US 6377855 B1	23-04-2002
			US 6381497 B1	30-04-2002
			US 6381498 B1	30-04-2002
			WO 9634568 A1	07-11-1996
			US 6405090 B1	11-06-2002
			US 6241753 B1	05-06-2001
			US 6470216 B1	22-10-2002
			US 6461378 B1	08-10-2002
			US 6430446 B1	06-08-2002
			US 5919219 A	06-07-1999
			US 2002062142 A1	23-05-2002
			US 6377854 B1	23-04-2002
WO 0100269	A	04-01-2001	US 6350276 B1	26-02-2002
			AU 5785300 A	31-01-2001

INTERNATIONAL SEARCH REPORT  
 information on patent family members

International Application No

PCT/US 03/03507

Patent document cited in search report	Publication date	Patent family member(s)	Publication date
WO 0100269	A	CA 2376879	A1 04-01-2001
		EP 1196215	A1 17-04-2002
		JP 2003503118	T 28-01-2003
		WO 0100269	A1 04-01-2001
		US 2002049483	A1 25-04-2002
<hr/>			
WO 9908614	A	25-02-1999	
		US 6480746	B1 12-11-2002
		US 6035238	A 07-03-2000
		US 6081749	A 27-06-2000
		AU 732188	B2 12-04-2001
		AU 9103898	A 08-03-1999
		CA 2300152	A1 25-02-1999
		EP 1003432	A1 31-05-2000
		JP 2001514921	T 18-09-2001
		WO 9908614	A1 25-02-1999
		US 6216704	B1 17-04-2001
		US 6546934	B1 15-04-2003
		US 2001014819	A1 16-08-2001
US 2001018606	A1 30-08-2001		
US 6533780	B1 18-03-2003		
<hr/>			