



- (51) International Patent Classification:  
G02C 7/04 (2006.01) G02C 7/06 (2006.01)
- (21) International Application Number:  
PCT/IL2018/051334
- (22) International Filing Date:  
05 December 2018 (05.12.2018)
- (25) Filing Language: English
- (26) Publication Language: English
- (71) Applicant: HANITA LENSES R.C.A. [IL/IL]; 2288500  
Kibbutz Hanita (IL).
- (72) Inventor: PORAT, Menachem; 2288500 Kibbutz Hanita  
(IL).

(74) Agent: SHORR, Ron et al.; Geyra Gassner Kesten, 55 Yigal Alon Street, 6789115 Tel Aviv (IL).

(81) Designated States (unless otherwise indicated, for every kind of national protection available): AE, AG, AL, AM, AO, AT, AU, AZ, BA, BB, BG, BH, BN, BR, BW, BY, BZ, CA, CH, CL, CN, CO, CR, CU, CZ, DE, DJ, DK, DM, DO, DZ, EC, EE, EG, ES, FI, GB, GD, GE, GH, GM, GT, HN, HR, HU, ID, IL, IN, IR, IS, JO, JP, KE, KG, KH, KN, KP, KR, KW, KZ, LA, LC, LK, LR, LS, LU, LY, MA, MD, ME, MG, MK, MN, MW, MX, MY, MZ, NA, NG, NI, NO, NZ, OM, PA, PE, PG, PH, PL, PT, QA, RO, RS, RU, RW, SA, SC, SD, SE, SG, SK, SL, SM, ST, SV, SY, TH, TJ, TM, TN, TR, TT, TZ, UA, UG, US, UZ, VC, VN, ZA, ZM, ZW.

(84) Designated States (unless otherwise indicated, for every kind of regional protection available): ARIPO (BW, GH, GM, KE, LR, LS, MW, MZ, NA, RW, SD, SL, ST, SZ, TZ, UG, ZM, ZW), Eurasian (AM, AZ, BY, KG, KZ, RU, TJ,

(54) Title: CONTACT LENS WITH ADAPTABLE CURVATURE

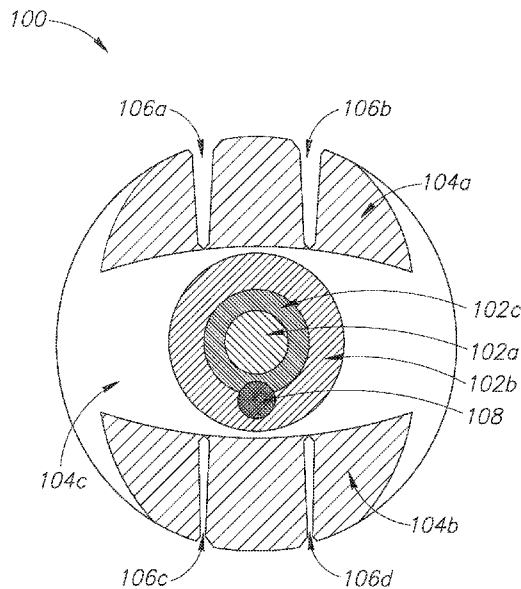

FIG. 2A

(57) Abstract: A soft contact lens that includes a dome-shaped flexible sheet of material. The dome-shaped flexible sheet of material includes: (a) a non-optic zone comprising the periphery of the dome-shaped flexible sheet of material, and including: an upper peripheral zone comprising an upper part of the periphery of the dome-shaped flexible sheet of material, and a lower peripheral zone comprising a lower part of the periphery of the dome-shaped flexible sheet of material. The curvature of the dome-shaped flexible sheet of material is dynamically adaptable, by virtue of at least one of the upper and lower peripheral zones being structured to laterally expand and contract; and (b) an optic zone disposed in an area of the dome-shaped flexible sheet of material that lies between the upper and lower peripheral zones, wherein the optic zone is configured to align with a visual axis of the eye.



TM), European (AL, AT, BE, BG, CH, CY, CZ, DE, DK, EE, ES, FI, FR, GB, GR, HR, HU, IE, IS, IT, LT, LU, LV, MC, MK, MT, NL, NO, PL, PT, RO, RS, SE, SI, SK, SM, TR), OAPI (BF, BJ, CF, CG, CI, CM, GA, GN, GQ, GW, KM, ML, MR, NE, SN, TD, TG).

**Published:**

— *with international search report (Art. 21(3))*

## **CONTACT LENS WITH ADAPTABLE CURVATURE**

### **CROSS-REFERENCE TO RELATED APPLICATIONS**

This application claims the benefit of priority of U.S. Provisional Patent  
5 Application No. 62/595,118, filed December 6, 2017, entitled “Contact Lens With  
Adaptable Curvature”, which is incorporated herein by reference in its entirety.

### **FIELD OF THE INVENTION**

The invention relates to the field of contact lenses.

10

### **BACKGROUND**

Multifocal lenses typically have two or more areas, or zones, with different optical  
powers, such as a far-power optic zone for distance vision, and a near-power optic zone  
for near or close up vision. In multifocal lenses, the zones may be further subdivided  
15 into additional power zones.

Effective use of a bifocal contact lens requires translation of an ocular system  
between vision surfaces when an eye changes from gazing at an object at a distance to  
gazing at a nearby object. Alternatively, there may be a desire to have a translating  
multifocal contact lens that may have one or more intermediate-power zones in addition  
20 to far and near-power optic zones. Such a translating contact lens may have to have an  
ability to control and optimize the amount of movement of a lens when the pupil  
translates from distance vision, to intermediate vision, to near vision, or any combination  
thereof.

While there are many designs for soft translating contact lenses, soft contact  
25 lenses typically have difficulty translating across the surface of the eye when the focus  
changes from a straight-ahead gaze, to a downward gaze. Some soft bifocal contact lens  
designs provide an integrally formed bevel to aid translation. While other lens designs  
may allow the lens to translate across the surface of an eye when the focus changes from  
a straight-ahead gaze to a downward gaze, they are less efficient at allowing to control  
30 lens movement of a lens during an eye's translation to a different visual direction.  
Another prior art example, describes a soft multifocal contact lens that has an integrally  
formed ramped ridge zone adjoining an outwardly extending latitudinal ridge that sits  
on an eyelid to aid in translation of a lens. The latitudinal ridge portion has a bump at  
each end, thereby increasing elevation height of the ends of the ridge compared to the

elevation height in the middle. However, a disadvantage of these and other known designs is discomfort to the wearer.

The foregoing examples of the related art and limitations related therewith are intended to be illustrative and not exclusive. Other limitations of the related art will become apparent to those of skill in the art upon a reading of the specification and a study of the figures.

## SUMMARY

The following embodiments and aspects thereof are described and illustrated in conjunction with systems, tools and methods which are meant to be exemplary and illustrative, not limiting in scope.

One embodiment relates to soft contact lens which comprises: a dome-shaped flexible sheet of material, comprising: (a) a non-optic zone comprising the periphery of the dome-shaped flexible sheet of material, wherein the non-optic zone is configured to cover a portion of the cornea and portion of the sclera of an eye, wherein the non-optic zone comprises: an upper peripheral zone comprising an upper part of the periphery of the dome-shaped flexible sheet of material, and a lower peripheral zone comprising a lower part of the periphery of the dome-shaped flexible sheet of material, wherein the curvature of the dome-shaped flexible sheet of material is dynamically adaptable, by virtue of at least one of the upper and lower peripheral zones being structured to laterally expand and contract; and (b) an optic zone disposed in an area of the dome-shaped flexible sheet of material that lies between the upper and lower peripheral zones, wherein the optic zone is configured to align with a visual axis of the eye.

In some embodiments, the lateral expansion of at least one of the upper and lower peripheral zones causes an at least 9% increase in a circumference of the dome-shaped flexible sheet of material at a 45° arc that is centered at the upper or lower peripheral zone, respectively; and the lateral contraction of at least one of the upper and lower peripheral zones causes an at least 9% decrease in a circumference of the dome-shaped flexible sheet of material at a 45° arc that is centered at the upper or lower peripheral zone, respectively.

In some embodiments, the soft contact lens further comprises at least two slits, wherein: each slit is an elongated portion cut out of the lens; each slit maintains a gap extending from the periphery of the membrane until the base of the slit towards an inner region of the membrane when the slit is in a normally neutral state; and each slit is

configured to open and close, thereby allowing the flexibility of the lens periphery in order to modify the curvature of the disk-shaped membrane.

In some embodiments, the gap of any one of the at least two slits is uniform along the length of the slit when the slit is in the normally neutral state.

5 In some embodiments, the gap of any of the at least two slits is non-uniform along the length of the slit when the slit is in the normally neutral state.

In some embodiments, any of the at least two slits has an elongated “U” shape when the slit is in the normally neutral state.

10 In some embodiments, any of the at least two slits has a “V” shape when the slit is in the normally neutral state.

In some embodiments, any of the at least two slits has a rectangular shape when the slit is in the normally neutral state.

In some embodiments, any of the at least two slits has a pointed picket shape when the slit is in the normally neutral state.

15 In some embodiments, the upper peripheral zone comprises at least one upper slit comprising at least one of the at least two elongated slits, wherein the at least one upper slit is configured to open and close, thereby dynamically adapting the curvature of the upper peripheral zone, and wherein the lower peripheral zone comprises at least one lower slit comprising at least another one of the at least two elongated slits, wherein the  
20 at least one lower slit is configured to open and close, thereby dynamically adapting the curvature of the lower peripheral zone.

In some embodiments, the at least one upper slit comprises at least two upper slits, and wherein the at least one lower slit comprises at least two lower slits.

25 In some embodiments, the optic zone comprises at least two optic zones having different dioptric powers.

In some embodiments, the optic zone comprises a distance vision zone, and a near vision zone, wherein the distance vision zone has a different dioptric power than the near vision zone.

In some embodiments, the optic zone has an aspheric configuration.

30 In some embodiments, the optic zone has a translating configuration.

In some embodiments, the optic zone has a concentric configuration, wherein the distance vision zone is located at the center of the optic zone, and wherein the near vision zone is ring-shaped and is located at the periphery of the optic zone.

In some embodiments, the optic zone further comprises a ring-shaped intermediate optic zone located between the distance vision zone and the near vision zone.

In some embodiments, the upper peripheral zone is configured to expand and the lower peripheral zone is configured to contract when the visual axis of the eye is aligned with the lower periphery of the optic zone, and wherein the upper peripheral zone and the lower peripheral zone are configured to be at a normally neutral state when the visual axis of the eye is aligned with the center of the optic zone.

In some embodiments, the soft contact lens further comprises a stabilizing middle zone positioned between the upper and lower peripheral zones, wherein the thickness of the stabilizing middle zone is greater than the thickness of the upper and lower peripheral zones.

In some embodiments, the soft contact lens has the following measurements: a length of each of the slits: 0.5-4 millimeters (mm), or 2-4 mm; and a gap provided by each of the slits: 0.1-1 mm.

In addition to the exemplary aspects and embodiments described above, further aspects and embodiments will become apparent by reference to the figures and by study of the following detailed description.

### **BRIEF DESCRIPTION OF THE FIGURES**

Exemplary embodiments are illustrated in referenced figures. Dimensions of components and features shown in the figures are generally chosen for convenience and clarity of presentation and are not necessarily shown to scale. The figures are listed below.

Figs. 1A-1B show a frontal view and a cross-sectional view, respectively, of a soft contact lens having an adaptable curvature and worn on an eye which gazes straight, in accordance with an embodiment;

Figs. 2A-2B show a frontal view and a cross-sectional view, respectively, of the soft contact lens of Figs. 1A-B worn on an eye which gazes downwards, in accordance with an embodiment;

Figs. 3A-3B show a frontal view and a cross-sectional view, respectively, of the soft contact lens of Figs. 1A-B worn on an eye which gazes upwards, in accordance with an embodiment;

Fig. 4 shows a frontal view of the soft contact lens of Figs. 1A-1B, with additional annotations and without a view of an iris, in accordance with an embodiment;

Fig. 5 shows a cross-sectional view of a soft contact lens, in accordance with an embodiment; and

Fig. 6 shows a frontal view of a soft contact lens having an adaptable curvature and worn on an eye which gazes straight, in accordance with an embodiment.

5

### DETAILED DESCRIPTION

A soft translating multifocal contact lens is disclosed herein, having a dynamically adaptable periphery that expands and contracts, allowing the lens to modify its curvature to accommodate the changing shape of the wearer's eye as the lens moves vertically over the eye's surface. Optionally, the lens is a multifocal lens. As the wearer shifts his focus between the different vision zones of the lens, the lens moves vertically over the surface of the eyeball, accordingly. The ability of the lens to accommodate its curvature to the varying curvature of the eye's surface may provide an easier and more comfortable experience for the wearer when shifting his focus to different regions of the lens.

15 The lens's periphery may be disposed with one or more slits that open and close, thereby dynamically changing the curvature of the periphery and enabling the lens to move vertically over the surface of the eye as the wearer switches his focus between the various multifocal optical zones of the lens.

Reference is now made to Figs. 1A, 1B, 2A, 2B, 3A, and 3B, which show a soft contact lens **100** having an adaptable curvature, in accordance with an embodiment. Each pair of these figures, namely 1A-B, 2A-B, and 3A-B, shows lens **100** in a frontal view and a cross-sectional view, respectively.

Lens **100** may be a dome-shaped flexible sheet of material (a suitable soft contact lens material), such as but not limited to silicon elastomers, silicone-containing macromers such as may include hydrogels, silicone-containing hydrogels, and the like. The surface of lens **100** may be a siloxane, or may include a substance having a siloxane functionality, such as polydimethyl siloxane macromers, methacryloxypropyl polydimethyl siloxane macromers, methacryloxypropyl polyalkyl siloxanes, and combinations thereof, and/or dilocone hydrogel or other hydrogel, such as etafilcon A.

30 For a further discussion of soft contact lenses and their tensile properties, as well as suitable materials for soft contact lenses, see Ioannis Tranoudis et al., "Tensile properties of soft contact lens materials", in Contact Lens & Anterior Eye 27(4):177-91, January 2005.

The center region of lens **100** may be an optic zone **102** that aligns with the wearer's visual axis and provides one or more sub-regions for corrective vision, details of which are provided below. The peripheral region of lens **100** bordering optic zone **102** may be a non-optic zone, that covers a portion of the cornea and sclera of the eye.

5 The non-optic zone may include three general sections: an upper peripheral zone **104a** and lower peripheral zone **104b** above and beneath the optic zone **102** at the upper and lower peripheries of lens **100**, as well as a stabilizing middle zone **104c** positioned between zones **104a** and **104b**, surrounding zone **102** from either side.

10 For the description that follows, it may be understood that the terms 'upper' and 'lower', and 'upwards' and 'downwards', are used for the purposes of clarity only, to accord the description with the drawings, and are not meant to be taken in an absolute sense. The lenses described herein below may have a symmetry about the horizontal axis, and thus the upper and lower features may be identical and interchangeable.

15 Non-optic zone **104** may include an upper peripheral zone **104a** located at the upper periphery of lens **100**, and a lower peripheral zone **104b** located at the lower periphery of lens **100**. The curvature of each of upper peripheral zone **104a** and lower peripheral zone **104b** may be dynamically adaptable, to allow modifying the overall curvature of lens **100** dynamically, and accommodate a vertical movement of lens **100** over the surface of the eye. This change of curvature may be expressed by a change in  
20 the circumference of lens **100** at one or two arcs extend over a certain angle at upper peripheral zone **104a** and lower peripheral zone **104b**. The arcs are illustrated in Fig. 4 – they are the circumference of lens **100** (disregarding the circumference of the slits) delimited between the dashed lines forming angles  $\alpha$  and  $\beta$ . The arcs may be, for example, of 45°. Namely, over upper and lower arcs of 45° each, the circumference may  
25 change between minus and plus 9% as lens **100** dynamically changes its curvature. These arcs are illustrated for the purpose of more clearly showing that the change of curvature of lens **100** is majorly expressed at these arcs, and less so (or not at all) beyond these arcs.

30 The at least 9% may be, in some embodiments, between 9-15%, 9-20%, 9-25%, 9-11%, 11-13%, 13-15%, 15-17%, 17-19%, 19-21%, 21-23%, 23-25%, or more than 25%. Each possibility represents a separate embodiment of the invention.

To achieve the curvature modification, one or more slits **106** may be provided with each of upper peripheral zone **104a** and lower peripheral zone **104b**, such as slits **106a**, **106b**, **106c**, and **106d**. Slits **106** may open at the periphery of lens **100** and close as

necessary to dynamically adapt the curvature of lens **100**, such as at peripheral zones **104a** and **104b**, accordingly. Optionally, lens **100** has two upper slits **106a**, **106b**, and two lower slits **106c**, **106d**, however it may be understood that this is but one implementation, and more or fewer slits may be used. For example, an alternative lens  
5 (not shown) may have three, or four, or five, or more upper slits, and three, or four, or five, or more, lower slits. Optionally, the number upper slits is different than the number of lower slits. For example, there may be more upper slits than lower slits, alternatively, there may be fewer upper slits than lower slits.

Slits **106** may be elongated and thin portions cut out of lens **100** that, in their  
10 normally neutral state (when the lens is in its rested state, namely when the wearer's gaze is straight ahead), maintain a gap extending from the periphery of lens **100** until the base of slits **106**, towards an inner region of lens **100**. When in the normally neutral state, slits **106** may have any suitable shape, such as but not limited to an elongated U-shape, V-shape, rectangular shape, a pointed picket-shape having a "V" shaped base  
15 pointing towards the center of lens **100** and elongated vertical walls extending to the periphery of lens **100**. In the normally neutral state, the gap maintained along the length any of slits **106** may be substantially uniform. Alternatively, in the normally neutral state, the gap along any of slits **106** may be non-uniform, for example the gap may be larger at the periphery of lens **100** and may taper towards the base of slits **106**. It may be  
20 appreciated that although slits **106** are shown having a uniform shape and size, this is not meant to be limiting, and different slits **106** on the same lens **100** may have a different shape and/or size. When opened, slits **106** increase the gap at the periphery of lens **100**, when closed, slits **106** may decrease the gap at the periphery of lens **100**. Slits **106** may fully close, closing the gap at the periphery of lens **100**. Slits **106** may partially open  
25 and/or partially close, increasing and/or decreasing the circumference of lens **100** as necessary.

Opening slits **106** opens a wider gap at the periphery of lens **100**, lengthening the circumference of lens **100**. Referring to Figs. 2A-B, upper slits **106a** and **106b** are open, lengthening the circumference of lens **100** at its upper periphery. When fully open, the  
30 gap caused by slits **106** at the periphery of lens **100** may range from 1 millimeter (mm) to 3 mm. When closed, the peripheral ends of slits **106** may touch (or be very close to one another, for example between 0.01 to 0.1 mm from each other), forming a teardrop shape, such as lower slits **106c** and **106d** of Fig. 2A, maintaining the uniform gap at the inner end of slits **100** and closing the gap at the periphery of lens **100**, shortening the

circumference of lens **100** at its lower periphery. The opening of slits **106** at any of upper and lower peripheral zones **104a** and **104b** causes their curvature to decrease and thus flatten, accordingly. Conversely, closing any of slits **106** at any of upper and lower peripheral zones **104a** and **104b** causes their curvature to increase and become more convex, accordingly. Figs. 3A-B show the opposite of Figs 2A-B, namely – upper slits **106a** and **106b** are closed, and lower slits **106c** and **106d** are open.

Since the sclera of the eye is slightly less convex than the cornea (or, in different terms, the radius of the sclera is larger than the radius of the cornea), dynamically modifying the curvature of the peripheral regions of lens **100** by opening and/or closing any of slits **106** may allow fitting its curvature to different vertical positions on the eye's surface, in which different areas of the lens are positioned over different areas of the sclera and the cornea. Without the dynamic modification of the curvature of lens **100**, a lens is at risk of remaining stationary on the eyeball when the wearer moves the eyeball around. Namely, a lens without dynamic curvature modification will likely move with the eyeball movement – up, down, right, and left. In contrast, the dynamic modification of present embodiments aids in ensuring that lens **100** can slide over the eyeball – but only up and down (vertically) and not laterally (horizontally) – when the wearer's gaze changes.

Optic zone **102** may include multiple sub-zones, each having a different dioptric power and correcting for a different type of refractive condition, such as a distance vision zone **102a** for correcting for myopia, a near vision zone **102b** for correcting for hyperopia, and **102c** for correcting for intermediate vision. Alternatively, these optic sub-zones or other optic sub-zones which are not shown, may have a different purpose. Although the configuration illustrated in the figures for the different corrective sub-zones of optic zone **102** is concentric, this is but one implementation and is not meant to be limiting. Other suitable configurations such as aspheric or translating configurations may be used, accordingly.

In general, with respect to any configuration for optic zone **102**, the upper peripheral zone **104a** is configured to expand and the lower peripheral zone **104b** is configured to contract when the visual axis of the eye is aligned with the lower periphery of the optic zone, allowing lens **100** to move vertically upwards with respect to the eyeball. Similarly, upper peripheral zone and the lower peripheral zone **104a** and **104b** are configured to be at their normally neutral state when the visual axis of the eye is aligned with the center of the optic zone.

Distance vision zone **102a**, may be substantially round-shaped and located at the center of the optic zone **102**, comprising the center of lens **100**, allowing the wearer to focus for distance by looking straight ahead when lens **100** is positioned centrally over the cornea. As shown in Figs. 1A-B, the wearer's pupil **108** is positioned in the middle of distance vision zone **102a** aligning his visual axis through the center of lens **100**, to correct his distance vision.

Near vision zone **102b** may be substantially ring-shaped and may be located at the periphery of the optic zone **102**, allowing the wearer to focus for near vision by looking down, such as when reading. As shown in Fig. 2A, the near vision zone **102b** comprising the bottom periphery of the optic zone **102** is positioned substantially over the wearer's pupil **108**, aligning his visual axis through the bottom of optic zone **102**, to correct his near vision. The difference between Figs. 1A-B and Figs. 2A-B may be appreciated as the position of lens **100**, centered over the cornea for distance vision in Figs. 1A-B, has shifted upwards relative to the pupil **108** in Figs. 2A-B when the wearer aligns his visual axis (pupil **108**) with the lower near vision zone **102b** for near vision. Such vertical shifting of lens **100** over the wearer's eyeball may be facilitated by modifying the curvature of the upper and lower peripheral zones **104a** and **104b** via slits **106a**, **106b**, **106c**, and **106d** to accommodate the changing curvature of the eyeball. Conversely, when the wearer aligns his visual axis (pupil **108**) with the upper near vision zone **102b** for near vision, as shown in Figs. 3A-3B, the position of lens **100** shifts downwards relative to pupil **108**.

Optionally, lens **100** may include a ring-shaped intermediate optic zone **102c** located between the distance vision zone **102a** and the near vision zone **102b** to correct for an intermediate focal distances ranging between far and near ranges. Shifting the visual axis to align with intermediate optic zone **102a** corrects the wearer's intermediate vision accordingly.

Optionally, lens **100** may include a zone for correcting astigmatism, and which may overlap or be separate from the corrective zones described above.

Reference is now made to Fig. 4, which, for the purposes of clarity, shows lens **100** of Fig. 1A with additional annotations, useful for conveying various measurements of the lens. The length of each of slits **106** may range from 0.5 to 4 mm, or more specifically from 2 to 4 mm, for example approximately 2.7 mm. Slits **106** may extend inwards, from the outer edge of lens **100**. Optionally, slits **106** may extend from the edge of lens **100** until the outer edge of optic zone **102**. Slits **106** may have a neutral 'straight'

position that maintains a uniform gap along the length of slit ranging from 0.1 to 1mm (Fig. 1A), for example approximately 0.5mm. The distance 'sg' between slits may range from 3.0 mm to 7.0 mm, for example approximately 5.0mm.

Optionally, one or more portions of middle zone **104c** of lens **100**, positioned  
5 between the upper and lower peripheral zones **104a** and **104b**, may be thicker than upper and lower peripheral zones **104a** and **104b**, serving to stabilize lens **100** horizontally over the eye. The total diameter of near vision zone **102b** may range between 8mm and 9mm and may be approximately 8.5mm. The total diameter of distance vision zone **102a** may range between 4mm and 5mm, for example approximately 4.5mm. The thickness  
10 of intermediate zone **104c** may range from 0.25mm and 0.75mm and may be approximately 0.5mm. The diameter D1 of lens **100** may range from 12mm and 16mm, and may be approximately 14.2mm. The thickness of lens **100** at middle zone **104c**, in Fig. 3A, may range from 0.3mm and 0.4mm, and may be approximately 0.35mm. The thickness of lens **100** at points at the thin areas, indicated in grey, may range from 0.2mm  
15 and 0.3mm, and may be approximately 0.25mm.

Some optical defects, such as astigmatism, are caused by a deformation of the cornea or inner source due to the inner shape of the eye's lens. Referring to Fig. 5, the curvature of the anterior face of the central optic zone **102a** may accommodate such deformations by having a different radius at the horizontal and vertical meridian.

The central optic zone **102a** portion of lens **100**, which is configured to rest over a  
20 human cornea, may be somewhat flatter (i.e., having a larger radius) than a typical cornea. The sagittal depth, S2, of the posterior face of the central optic zone **102a**, may be smaller than the sagittal depth S1 of the cornea, resulting in a gap of S1 minus S2 between lens **100** and the eye's surface at the cornea. This gap may reduce surface  
25 tension between lens **100** and the surface of the eye, allowing the lens **100** to move over the surface of the eye more freely.

Optionally, the gap may range from 0.001 mm to 0.1 mm. This gap, caused by the relative flatness of lens **100**, together with slits **106** allow lens **100** to move over the eye's surface in response to the user's change of focus.

The vertical motion of lens **100** over the eye is now described:  
30

Referring to Figs. 1A-B, slits **106** are at a normally neutral state when the pupil **108** is positioned over the center of lens **100**, aligning the visual axis of the eye (pupil **108**) with the distance vision zone **102a** at the center of lens **100**.

Referring to Figs. 2A-B, as the wearer turns his gaze downwards, such as to read, the eyeball rotates downwards, shifting the visual axis of his eye down to the lower near vision zone **102b**. As the wearer blinks, his lower and upper eyelids may push lens **100** upwards. Upper slits **106a** and **106b** open, expanding upper peripheral zone **104a** slightly, and flattening the curvature of lens **100** at upper peripheral zone **104a** to accommodate the slightly less convex sclera above the cornea. At the same time, lower slits **106c** and **106d** close, contracting lower peripheral zone **104b** slightly, and increasing the curvature of lens **100** at lower peripheral zone **104b** to accommodate the slightly more convex cornea, now aligned with near vision zone **102b** at the lower portion of optic zone **102**, adjacent to the upper portion of lower peripheral zone **104b**. Modifying the curvature of lens **100** thus, and reducing its surface tension with the surface of the eyeball may facilitate this upwards motion over the surface of the eyeball.

When the wearer shifts his gaze back for distance vision, slits **106** revert to their normally neutral state as shown in Figs. 1A-B, and lens **100** returns to be centrally aligned over the cornea, with the pupil **108** positioned centered in distance vision zone **102a**.

Figs. 3A-B show the opposite of Figs. 2A-B. Namely, in Figs. 3A-B, the wearer turns his gaze upwards, the eyeball rotates upwards, shifting the visual axis of his eye up to the upper near vision zone **102b**. Lower slits **106c** and **106d** open, expanding lower peripheral zone **104b** slightly, and flattening the curvature of lens **100** at lower peripheral zone **104b** to accommodate the slightly less convex sclera below the cornea. At the same time, upper slits **106a** and **106b** close, contracting upper peripheral zone **104a** slightly, and increasing the curvature of lens **100** at upper peripheral zone **104b** to accommodate the slightly more convex cornea, now aligned with near vision zone **102b** at the lower portion of optic zone **102**, adjacent to the lower portion of upper peripheral zone **104b**.

The optical properties described above may be implemented on both sides of lens **100**, allowing the wearer to place either face of the lens on the surface of the eye, to correct the vision accordingly. For example, correction for astigmatism, myopia and hyperopia may be implemented on any side of lens **100**. Lens **100** may be a Toric lens and may be produced using any suitable technology, such as by standard lath cut, molded, oscillation system, or diffractive technology.

It may be appreciated that the lens described above allows the lens to move over the eyeball while avoiding some of the drawbacks of the ballasted lens designs. Ballasted lenses are typically thicker at their lower half to provide stability. However, this

thickness at the lower half may cut off the supply of oxygen to the cornea and regions of the sclera, interfering with the proper metabolism of these tissues and leading to discomfort by the wearer.

Lens **100** may be manufactured using any suitable method, such as but not limited to spin-cast techniques, injection moulding, cast moulding, etc. For example, a suitable cast moulding technique is described PCT Publication No. WO2013/033752 to Ezekiel.

Reference is now made to Fig. 6, which shows a soft contact lens **200** having an adaptable curvature, in accordance with an embodiment. Lens **200** is similar to lens **100** of the former figures, with the notable difference that lens **200** is truncated **210** at its lower area, and is devoid of a lower peripheral zone. Reference numerals in Fig. 6 are larger by 100 than their corresponding elements in the previous figures, to simplify the discussion. All these elements may be identical across Fig. 6 and the other figures.

This truncated structure of lens **200** avoids the need for lower peripheral slits, because there is now nothing in the lower area of the lens which prevents it from freely sliding over the varying curvature of the cornea and/or sclera.

The truncation line may be straight, as shown in Fig. 6, or may be arcuate or have any other shape (not shown). The truncation line may be perpendicular to a longitudinal dimension of slits **206a-b**, or be disposed at an angle of, for example, 60 to 120 degrees relative to that longitudinal dimension (not shown).

The truncation line may border with optic zone **202**, or be slightly distant from it, such as at a distance of 0.3-0.6 mm, 0.6-0.9 mm, 0.9-1.2 mm, 1.2-1.5 mm, 1.5-1.8 mm, or more than 1.8 mm from the optic zone. Each possibility represents a separate embodiment of the invention.

Those of skill in the art will also readily recognize an opposite embodiment (not shown), in which the truncation line is at the top of the lens and the one or more slits are at its bottom.

In the figures, elements are not always provided with reference numbers; a certain element, for example, may be provided with a reference number in one of more figures, and be shown without that reference number in other one or more figures – merely for reasons of brevity. Since all figures in this application show the same device, it is intended that an element having the same shape and appearing in different figures, sometimes with a reference number and sometimes not – be interpreted as the same element.

In the description and claims of the application, each of the words “comprise” “include” and “have”, and forms thereof, are not necessarily limited to members in a list with which the words may be associated.

## CLAIMS

What is claimed is:

1. A soft contact lens, comprising:

a dome-shaped flexible sheet of material, comprising:

- 5 (a) a non-optic zone comprising the periphery of the dome-shaped flexible sheet of material, wherein the non-optic zone is configured to cover a portion of the cornea and portion of the sclera of an eye, wherein the non-optic zone comprises:

10 an upper peripheral zone comprising an upper part of the periphery of the dome-shaped flexible sheet of material, and

a lower peripheral zone comprising a lower part of the periphery of the dome-shaped flexible sheet of material,

15 wherein the curvature of the dome-shaped flexible sheet of material is dynamically adaptable, by virtue of at least one of the upper and lower peripheral zones being structured to laterally expand and contract; and

- (b) an optic zone disposed in an area of the dome-shaped flexible sheet of material that lies between the upper and lower peripheral zones, wherein the optic zone is configured to align with a visual axis of the eye.

2. The soft contact lens of claim 1, wherein:

20 the lateral expansion of at least one of the upper and lower peripheral zones causes an at least 9% increase in a circumference of the dome-shaped flexible sheet of material at a 45° arc that is centered at the upper or lower peripheral zone, respectively; and

25 the lateral contraction of at least one of the upper and lower peripheral zones causes an at least 9% decrease in a circumference of the dome-shaped flexible sheet of material at a 45° arc that is centered at the upper or lower peripheral zone, respectively.

3. The soft contact lens of any one of claims 1 and 2, further comprising at least one slit, wherein:

30 each slit is an elongated portion cut out of the lens;

each slit maintains a gap extending from the periphery of the membrane until the base of the slit towards an inner region of the membrane when the slit is in a normally neutral state; and

each slit is configured to open and close, thereby allowing the flexibility of the lens periphery in order to modify the curvature of the disk-shaped membrane.

4. The soft contact lens of claim 3, wherein the gap of any one of the at least one slit is uniform along the length of the slit when the slit is in the normally neutral state.
5. The soft contact lens of claim 3, wherein the gap of any of the at least one slit is non-uniform along the length of the slit when the slit is in the normally neutral state.
6. The soft contact lens of claim 3, wherein any of the at least one slit has an elongated “U” shape when the slit is in the normally neutral state.
7. The soft contact lens of claim 3, wherein any of the at least one slit has a “V” shape when the slit is in the normally neutral state.
8. The soft contact lens of claim 3, wherein any of the at least one slit has a rectangular shape when the slit is in the normally neutral state.
9. The soft contact lens of claim 3, wherein any of the at least one slit has a pointed picket shape when the slit is in the normally neutral state.
10. The soft contact lens of any one of claims 3-9, wherein the at least one slit is at least two slits.
11. The soft contact lens of claim 10, wherein the upper peripheral zone comprises at least one upper slit comprising at least one of the at least two elongated slits, wherein the at least one upper slit is configured to open and close, thereby dynamically adapting the curvature of the upper peripheral zone, and wherein the lower peripheral zone comprises at least one lower slit comprising at least another one of the at least two elongated slits, wherein the at least one lower slit

is configured to open and close, thereby dynamically adapting the curvature of the lower peripheral zone.

- 5 12. The soft contact lens of claim 11, wherein the at least one upper slit comprises at least two upper slits, and wherein the at least one lower slit comprises at least two lower slits.
- 10 13. The soft contact lens of any one of claims 3-9, wherein:  
the upper peripheral zone comprises the at least one slit, wherein the at least one slit is configured to open and close, thereby dynamically adapting the curvature of the upper peripheral zone, and  
the lower peripheral zone is truncated.
- 15 14. The soft contact lens of any one of claims 3-9, wherein:  
the lower peripheral zone comprises the at least one slit, wherein the at least one slit is configured to open and close, thereby dynamically adapting the curvature of the lower peripheral zone, and  
the upper peripheral zone is truncated.
- 20 15. The soft contact lens of any one of claims 1 and 3, wherein the optic zone comprises at least two optic zones having different dioptric powers.
16. The soft contact lens of claim 15, wherein the optic zone comprises a distance vision zone, and a near vision zone, wherein the distance vision zone has a different dioptric power than the near vision zone.
17. The soft contact lens of claim 15, wherein the optic zone has an aspheric configuration.
18. The soft contact lens of claim 15, wherein the optic zone has a translating configuration.
- 25 19. The soft contact lens of claim 15, wherein the optic zone has a concentric configuration, wherein the distance vision zone is located at the center of the optic zone, and wherein the near vision zone is ring-shaped and is located at the periphery of the optic zone.

20. The soft contact lens of claim 19, wherein the optic zone further comprises a ring-shaped intermediate optic zone located between the distance vision zone and the near vision zone.
- 5 21. The soft contact lens of any one of claims 1 and 3, wherein the upper peripheral zone is configured to expand and the lower peripheral zone is configured to contract when the visual axis of the eye is aligned with the lower periphery of the optic zone, and wherein the upper peripheral zone and the lower peripheral zone are configured to be at a normally neutral state when the visual axis of the eye is aligned with the center of the optic zone.
- 10 22. The soft contact lens of any one of claims 1 and 3, further comprising a stabilizing middle zone positioned between the upper and lower peripheral zones, wherein the thickness of the stabilizing middle zone is greater than the thickness of the upper and lower peripheral zones.
- 15 23. The soft contact lens of claim 3, having the following measurements:  
a length of each of the slits: 0.5-4 millimeters (mm); and  
a gap provided by each of the slits: 0.1-1 mm.
24. The soft contact lens of claim 3, wherein the length of each of the slits is between 2-4 mm.

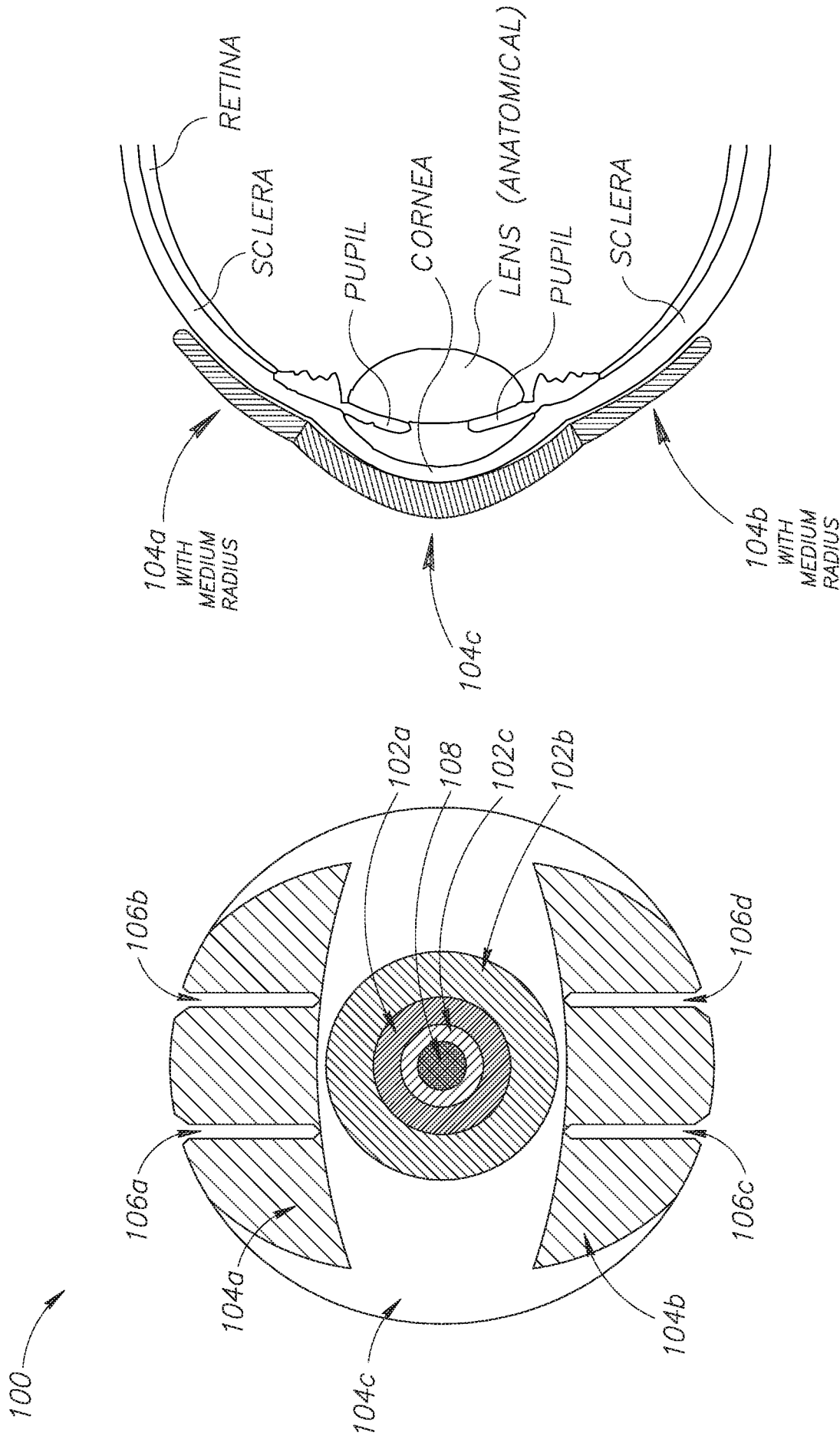

FIG.1B

FIG.1A

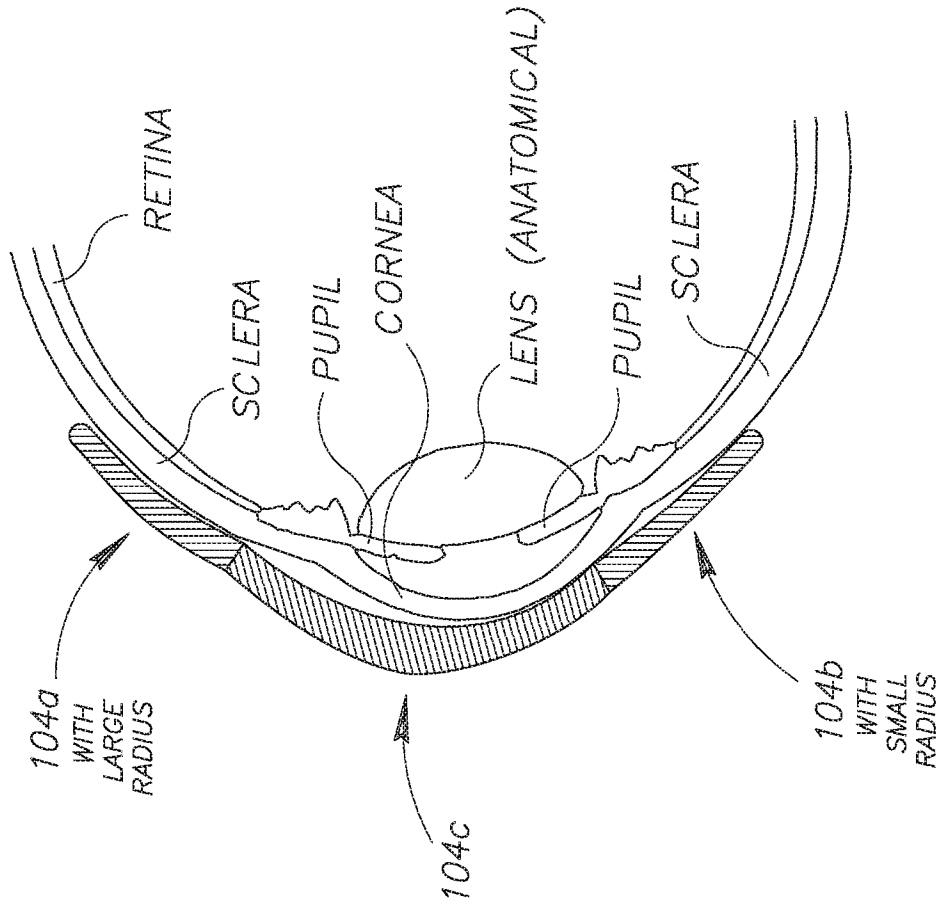

FIG. 2B

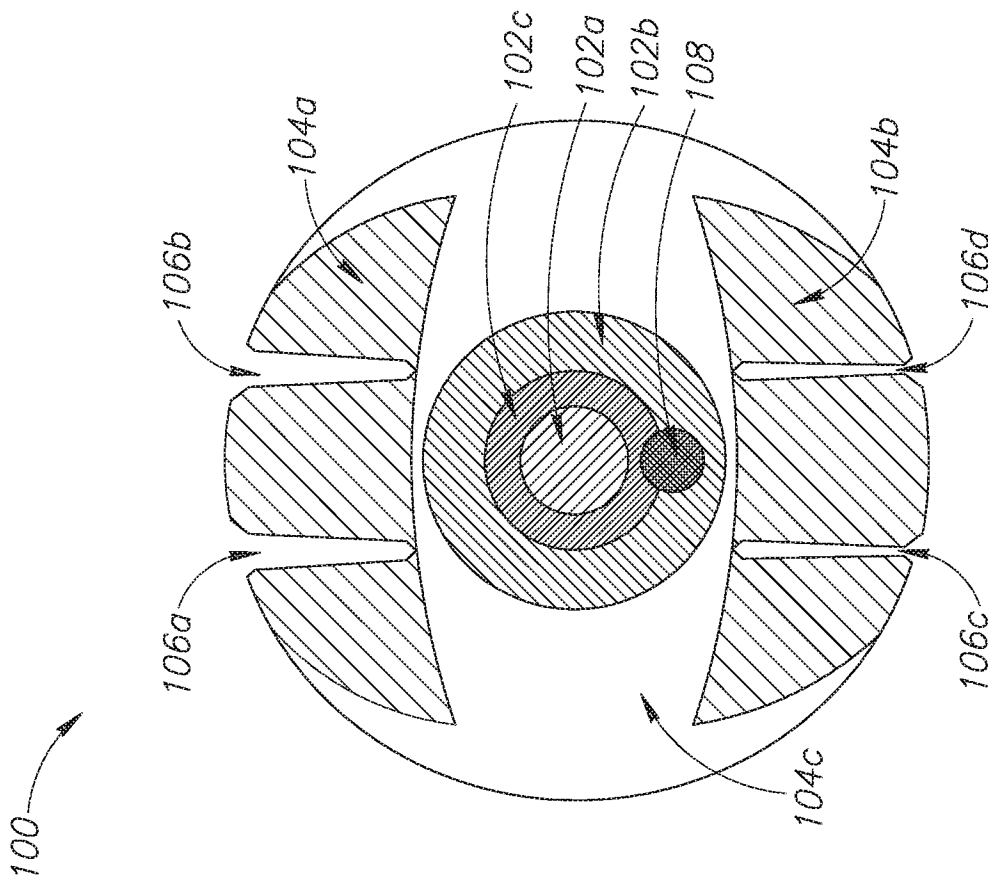

FIG. 2A

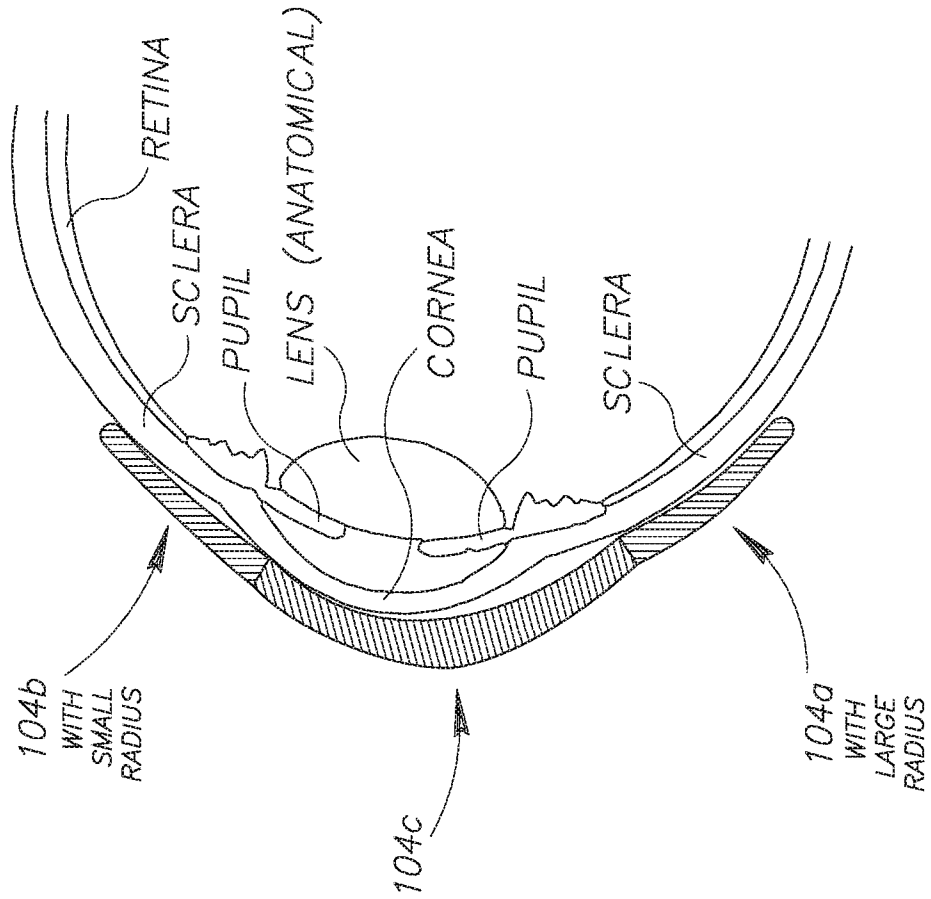

FIG. 3B

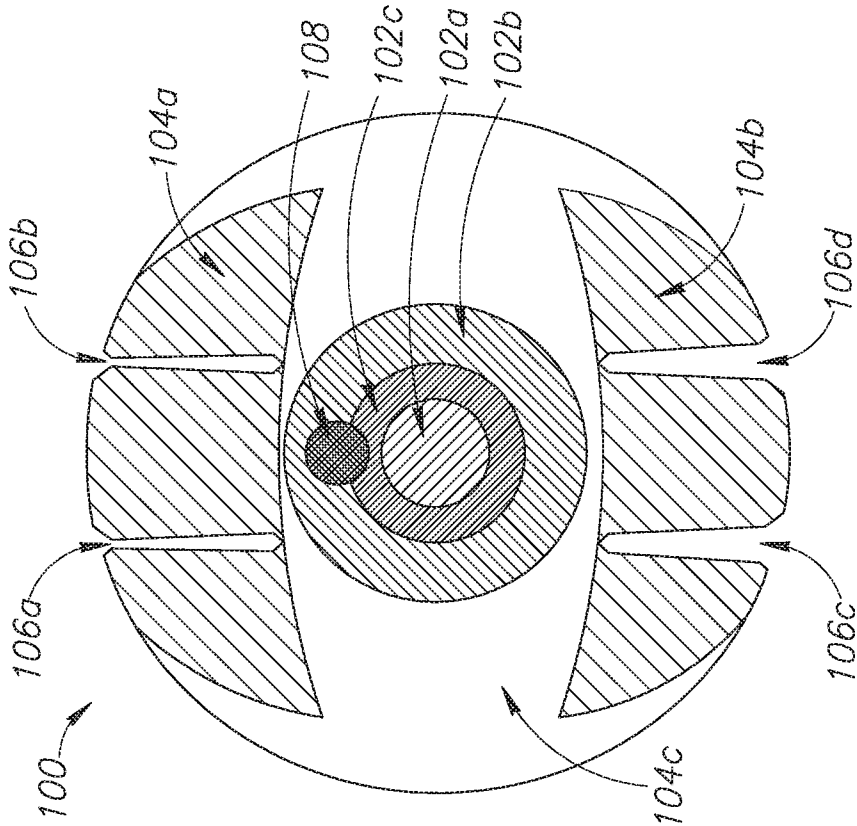

FIG. 3A

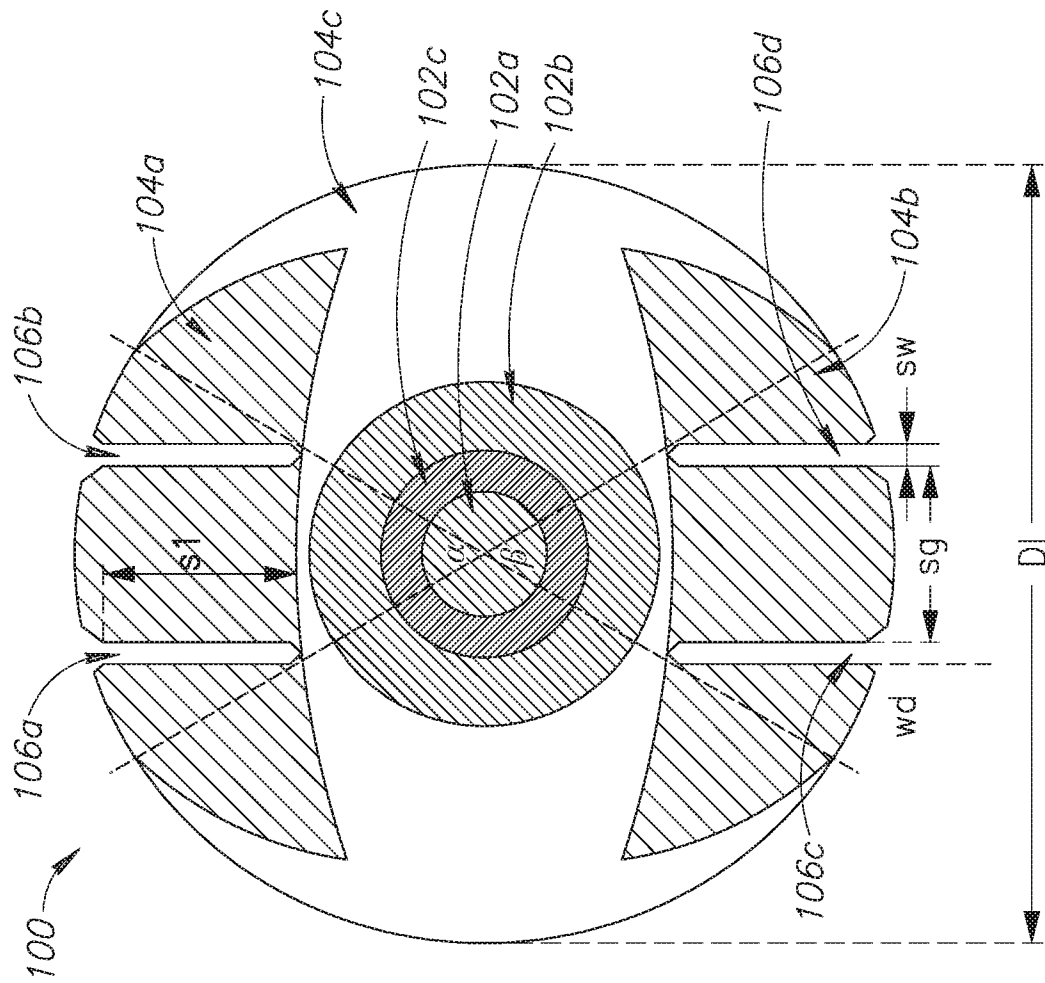

FIG.4

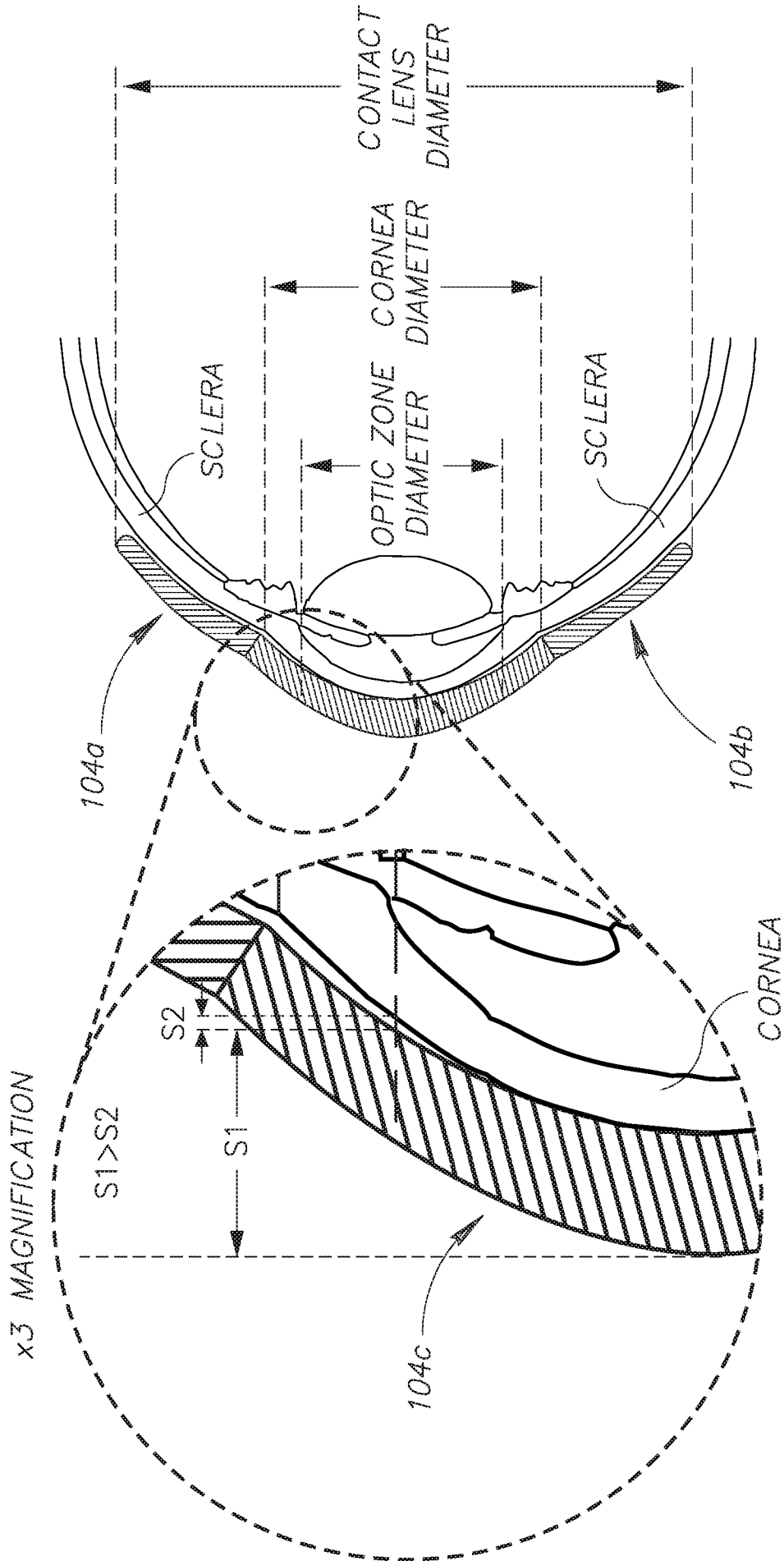

FIG.5

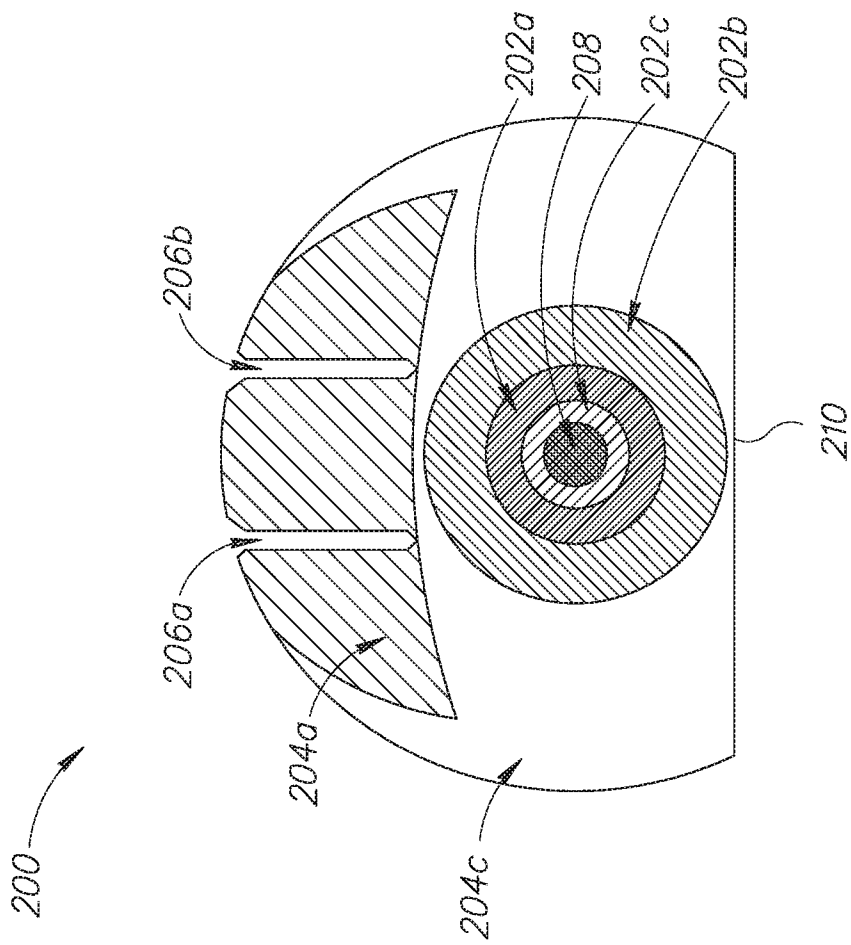

FIG.6

## INTERNATIONAL SEARCH REPORT

International application No.

PCT/IL2018/051334

## A. CLASSIFICATION OF SUBJECT MATTER

IPC (2019.01) G02C 7/04, G02C 7/06

According to International Patent Classification (IPC) or to both national classification and IPC

## B. FIELDS SEARCHED

Minimum documentation searched (classification system followed by classification symbols)

IPC (2019.01) G02C 7/04

Documentation searched other than minimum documentation to the extent that such documents are included in the fields searched

Electronic data base consulted during the international search (name of data base and, where practicable, search terms used)

Databases consulted: Google Patents, Derwent Innovation, Orbit

## C. DOCUMENTS CONSIDERED TO BE RELEVANT

Category*	Citation of document, with indication, where appropriate, of the relevant passages	Relevant to claim No.
X	WO 9814820 A1 UNIV SOUTH CAROLINA 04 Apr 1998 (1998/04/04) The whole document	1,2,15-22
A	The whole document	3-14,23,24
A	US 2010245760 A1 WIN-HALL DOROTHY 30 Sep 2010 (2010/09/30) The whole document	1-24
A	US 2017227788 A1 VISIONEERING TECH INC 10 Aug 2017 (2017/08/10) The whole document	1-24
A	CA 2678025 A1 PEXELOPTICS INC 28 Aug 2008 (2008/08/28) The whole document	1-24

 Further documents are listed in the continuation of Box C. See patent family annex.

\* Special categories of cited documents:

"A" document defining the general state of the art which is not considered to be of particular relevance

"E" earlier application or patent but published on or after the international filing date

"L" document which may throw doubts on priority claim(s) or which is cited to establish the publication date of another citation or other special reason (as specified)

"O" document referring to an oral disclosure, use, exhibition or other means

"P" document published prior to the international filing date but later than the priority date claimed

"T" later document published after the international filing date or priority date and not in conflict with the application but cited to understand the principle or theory underlying the invention

"X" document of particular relevance; the claimed invention cannot be considered novel or cannot be considered to involve an inventive step when the document is taken alone

"Y" document of particular relevance; the claimed invention cannot be considered to involve an inventive step when the document is combined with one or more other such documents, such combination being obvious to a person skilled in the art

"&amp;" document member of the same patent family

Date of the actual completion of the international search

14 Mar 2019

Date of mailing of the international search report

24 Mar 2019

Name and mailing address of the ISA:

Israel Patent Office

Technology Park, Bldg.5, Malcha, Jerusalem, 9695101, Israel

Facsimile No. 972-2-5651616

Authorized officer

Zreiqi Asia

Telephone No. 972-5651771

**INTERNATIONAL SEARCH REPORT**  
Information on patent family members

International application No.  
PCT/IL2018/051334

Patent document cited search report	Publication date	Patent family member(s)	Publication Date
WO 9814820 A1	04 Apr 1998	WO 9814820 A1	09 Apr 1998
		AU 4895097 A	24 Apr 1998
		US 5764339 A	09 Jun 1998
US 2010245760 A1	30 Sep 2010	US 2010245760 A1	30 Sep 2010
		US 7866815 B2	11 Jan 2011
US 2017227788 A1	10 Aug 2017	US 2017227788 A1	10 Aug 2017
		AU 2016201071 A1	24 Aug 2017
		AU 2016201071 B2	14 Dec 2017
		CN 107065218 A	18 Aug 2017
		EP 3206077 A1	16 Aug 2017
		SG 10201603913S A	28 Sep 2017
		SG 10201705911Y A	28 Sep 2017
		US 2018356651 A1	13 Dec 2018
		CA 2678025 A1	28 Aug 2008
		AR 065466 A1	10 Jun 2009
		AU 2008218240 A1	28 Aug 2008
		AU 2008218240 B2	30 Jan 2014
		AU 2009225638 A1	24 Sep 2009
		BR PI0807560 A2	01 Jul 2014
		BR PI0908992 A2	24 Nov 2015
		CA 2718521 A1	24 Sep 2009
		CN 101669059 A	10 Mar 2010
		CN 101669059 B	11 Sep 2013
		CN 102083390 A	01 Jun 2011
		EP 1980619 A1	15 Oct 2008
		EP 2115519 A2	11 Nov 2009
		EP 2115519 A4	05 Dec 2012
		EP 2271964 A2	12 Jan 2011

**INTERNATIONAL SEARCH REPORT**  
Information on patent family members

International application No.  
PCT/IL2018/051334

Patent document cited search report	Publication date	Patent family member(s)	Publication Date
		EP 2271964 A4	20 Sep 2017
		IL 200423 D0	29 Apr 2010
		JP 2011515157 A	19 May 2011
		KR 20090094047 A	02 Sep 2009
		KR 20100114133 A	22 Oct 2010
		MX 2009008829 A	28 Oct 2011
		TW 200848002 A	16 Dec 2008
		US 2009204207 A1	13 Aug 2009
		US 7926940 B2	19 Apr 2011
		US 2009033863 A1	05 Feb 2009
		US 8215770 B2	10 Jul 2012
		WO 2008103906 A2	28 Aug 2008
		WO 2008103906 A3	06 Nov 2008
		WO 2008122449 A1	16 Oct 2008
		WO 2009117506 A2	24 Sep 2009
		WO 2009117506 A3	07 Jan 2010