

P. C. EVANS & H. J. H. KING.
CARDING MACHINE FEEDER.

No. 107,890.

Patented Oct. 4, 1870.

FIG. 1.

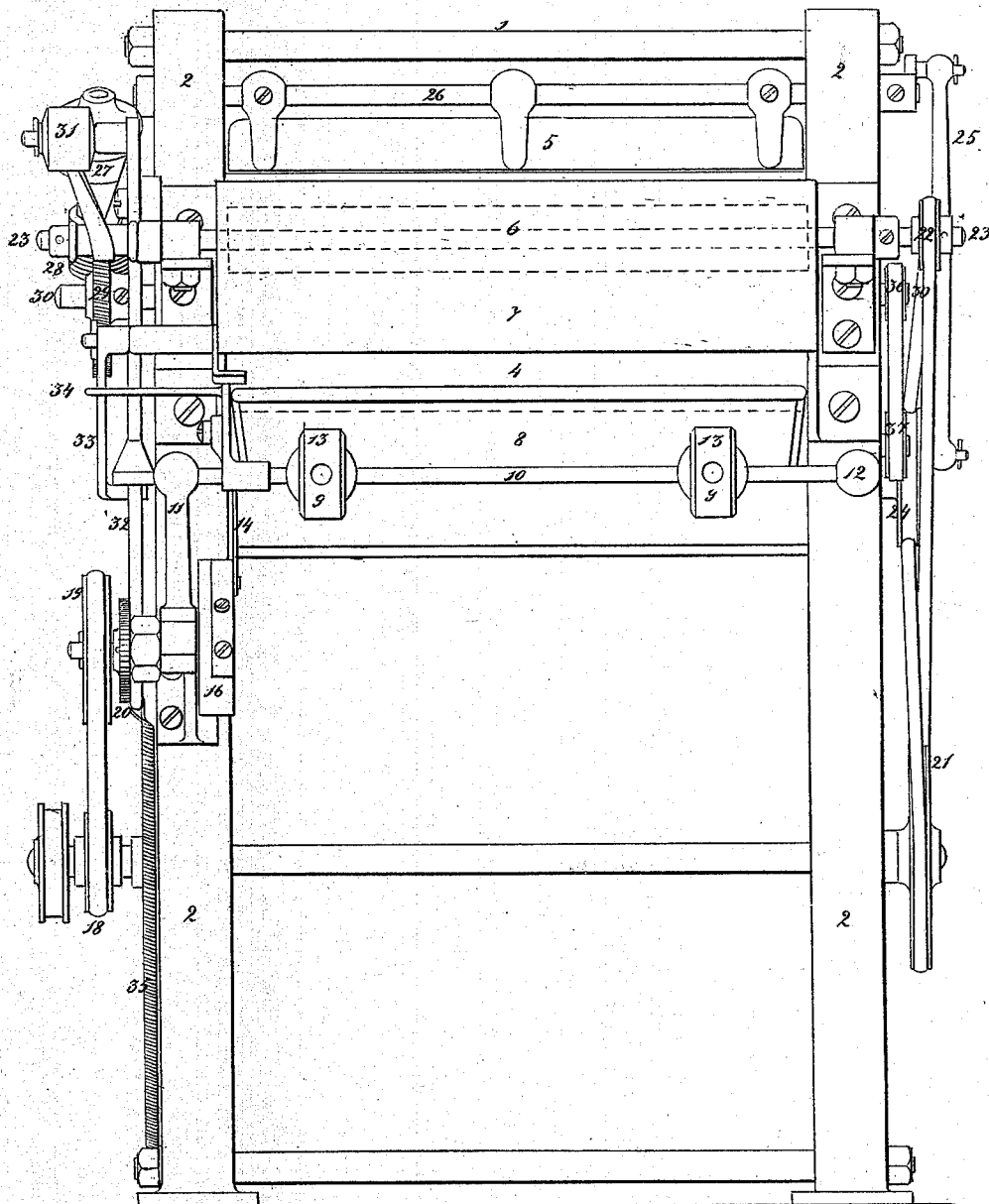

Witnesses
J. H. Adam
Robert Rose

P. C. Evans
H. J. H. King
by M. H. Boyce
Atty

P. C. EVANS & H. J. H. KING.
CARDING MACHINE FEEDER.

No. 107,890.

Patented Oct. 4, 1870.

FIG. 2.

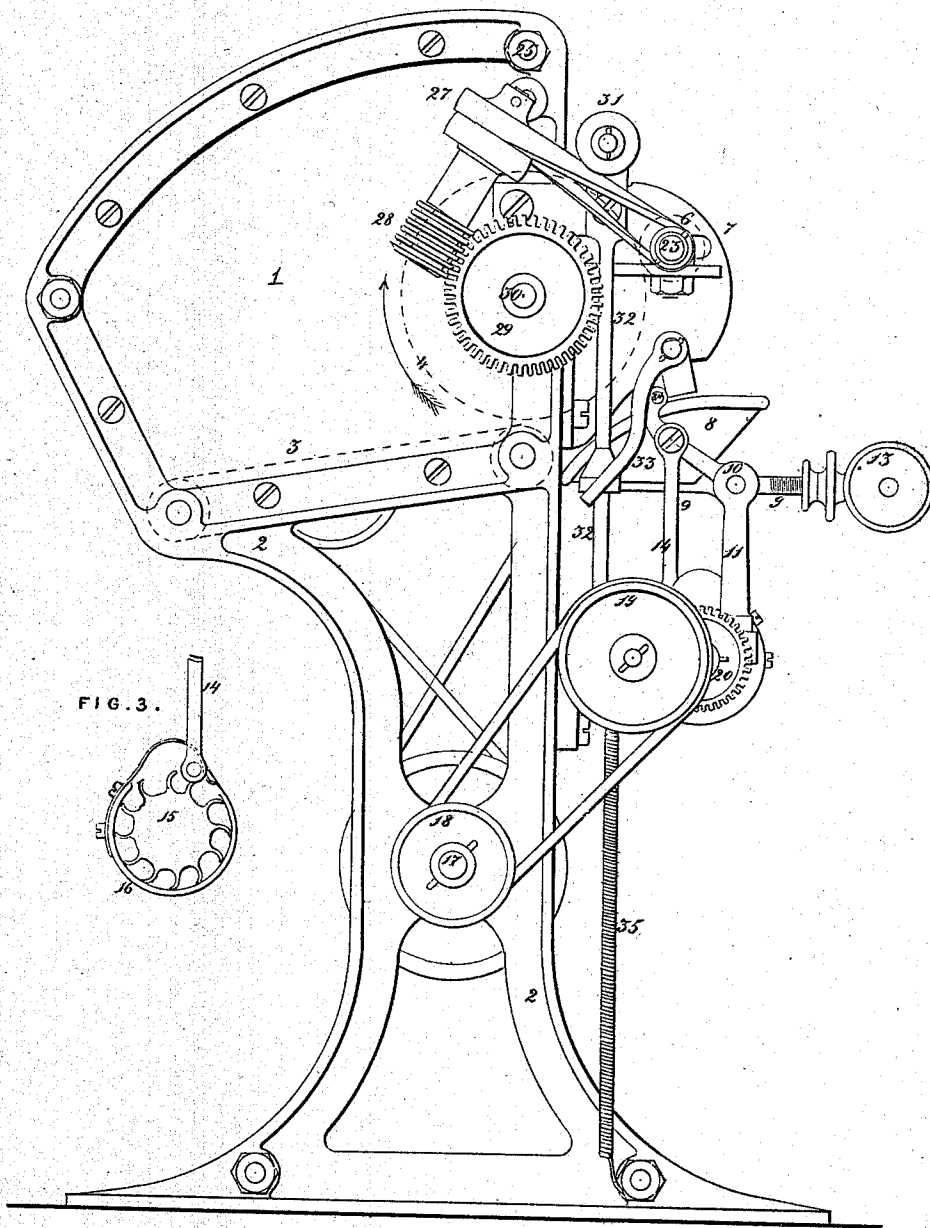

FIG. 3.

Witnesses
J. H. Adams
Robert Rose

P. C. Evans
H. J. H. King
by W. W. Boyce
Atty

United States Patent Office.

PHILIP CHARLES EVANS, OF BRIMSCOMBE, ENGLAND, AND HENRY JAMES HOGG KING, OF GLASGOW, SCOTLAND.

Letters Patent No. 107,890, dated October 4, 1870.

IMPROVEMENT IN WEIGHING-ATTACHMENTS FOR CARDING-MACHINE FEEDERS.

The Schedule referred to in these Letters Patent and making part of the same

We, PHILIP CHARLES EVANS, of Brimscombe, in the county of Gloucester, England, and HENRY JAMES HOGG KING, of Glasgow, in the county of Lanark, Scotland, have jointly invented certain Improved Apparatus for Feeding Wool, Cotton, or other Fibrous Materials to Carding or other Machines, of which the following is a specification.

Nature and Objects of the Invention.

This invention relates to the combining of feeding and weighing appliances, by means of which the fibrous materials are transferred from a heap to an endless apron, such as is usually employed for feeding or entering such materials to carding-machines; the materials being weighed in separate quantities and supplied at regular intervals, by which means greater uniformity and regularity can be obtained than is possible with the ordinary process of feeding by hand.

Description of the Accompanying Drawing.

Figure 1 is an elevation of the front which faces the carding or other machine.

Figure 2 is a side elevation.

Figure 3 is an inside view of mechanism for emptying the weighing scale.

General Description.

A box or hopper, 1, carried upon side standards 2, is provided, into which the fibrous materials are thrown in a loose state.

An endless apron, shown by dotted lines at 3 in fig. 2, forms the bottom of the box, and is moved in the direction to carry the fibrous materials toward the front where there is a roller, 4, shown by a dotted circle in fig. 2.

This roller 4 has hooks fixed all over its surface, and, turning in the direction shown by the arrow, picks up the fibrous materials and carries them round over its top, any excess being prevented from passing over by a vibrating paddle, 5.

A revolving paddle, indicated by dotted lines at 6 in fig. 1, and working under a hood or cover, 7, beats the fibrous materials off the hooked roller 4, so that they fall into a weighing-scale, 8. This scale 8 is carried by arms 9 on a horizontal spindle, 10, supported by brackets 11 12, and is counterbalanced by adjustable weights 13.

To one end of the weighing scale 8 there is loosely jointed a pendent-rod, 14, having at its bottom end a pin projecting across a hook-toothed wheel, 15, shown separately in fig. 3, and which is constantly revolving inside of an open box, 16. The rim of the box is nearly in contact with the teeth of the wheel, round

the sides and bottom, but is at the top shaped to allow the pin of the pendent rod 14 to rise clear of the teeth, the top consisting of spring, which allows the parts to yield when the point of a tooth happens to strike the pin improperly. As soon as the accumulation of the fibrous materials in the scale 8 causes the scale to begin to descend, the pin of the pendent-rod 14 engages with the toothed wheel 15, and that wheel draws down the scale quickly, emptying it, and then carries it up again. The fibrous materials drop from the scale 8 down upon an endless apron, not shown in the drawing, but which carries them into the carding or other machine.

The various movements hereinbefore described are all derived from a transverse horizontal shaft, 17, which is itself to be driven from the carding or other machine by means of a pitch, chain, or otherwise. A cord transmits motion from a pulley, 18, on the shaft 17, to a pulley, 19, which is on a stud, and which has fast to it a pinion, gearing with a spur-wheel, 20, fast on the spindle of the toothed wheel 15, which draws down the weighing-scale.

From another pulley, 21, on the shaft 17, a cord transmits motion to two pulleys, one, 22, being on the spindle 23 of the doffing-paddle 6, and the other, 24, on a stud and having an eccentric-pin, which, by a connecting-rod, 25, jointed to a crank-arm on the spindle 26 of the paddle 5, gives the vibrating motion to that paddle.

The hooked roller 4 is driven by means of the spindle 23 of the doffing-paddle 6, a belt from that spindle being passed round fast and loose pulleys 27 on an inclined spindle, which has fast on it a worm, 28, gearing with a worm-wheel, 29, fast on the spindle 30 of the hooked roller 4. From the positions of the parts, the belt tends to run on the upper pulley 27, which is the fast one; but when the weighing-scale 8 is being emptied, a roller, 31, carried by a vertical rod, 32, presses the belt down upon the loose pulley 27, in consequence of which the motion of the hooked roller ceases for the time.

The rod 32 is held up by a catch-lever, 33, which engages under a shoulder formed on it, but when the weighing-scale 8 begins to descend, a pin, 34, fixed to it, throws off the catch-lever 33, and the rod 32 descends by its own weight, aided, if necessary, by a spring, 35. After each emptying of the scale 8 the feeding is discontinued until the rod 32 is again raised, which is done by a cam adapted to the speed and requirements of the carding or other machine. Thus it may be conveniently done by a cam on the spindle of the outermost roller of the feed or entering apron of a carding-machine.

A pulley, 36, on the spindle 30 of the hooked roller

transmits motion, by a cord, to a pulley, 37, on the spindle of one of the rollers of the endless apron 3 at the bottom of the box or hopper 1.

Claims.

We claim as our invention—

1. In an apparatus for supplying material to carding and other machines, a self-discharging scale, substantially as described, operating as and for the purpose set forth.

2. In an apparatus for supplying material to carding and other machines, a scale, operated substantially as described, to automatically cut off the supply when it begins its discharge.

3. The toothed wheels 15, in combination with the weighing and discharging device 8 and rod 14, substantially as and for the purpose described.

4. The supply cut-off, consisting of the catch-lever 33, pin 34, and rod 32, in connection with the scale, substantially as and for the purpose described.

PHILIP C. EVANS.

H. J. H. KING.

Witnesses to PHILIP CHARLES EVANS' signature:

WILLIAM NASH, *Weston-Super-Mare,*

WALTER ASHLEY, *Weston-Super-Mare.*

Witnesses to HENRY JAMES HOGG KING's signature:

EDMUND HUNT, *Glasgow,*

ALEXR. TEMPLETON, *Glasgow.*