



US00D952445S

(12) **United States Design Patent**
Cope et al.

(10) **Patent No.:** **US D952,445 S**

(45) **Date of Patent:** **** May 24, 2022**

- (54) **LINEAR DOUBLE TRACK RAIL**
- (71) Applicant: **Magellan Company Pty Ltd**,
Chatswood (AU)
- (72) Inventors: **Alex Cope**, Chatswood (AU); **Glen Cassim**, Chatswood (AU)
- (73) Assignee: **Magellan Company Pty Ltd**,
Chatswood (AU)
- (**) Term: **15 Years**
- (21) Appl. No.: **29/710,745**
- (22) Filed: **Oct. 25, 2019**
- (30) **Foreign Application Priority Data**
May 6, 2019 (AU) 201912449
- (51) **LOC (13) Cl.** **09-06**
- (52) **U.S. Cl.**
USPC **D8/356**
- (58) **Field of Classification Search**
USPC D8/356, 354, 349, 367, 394, 395, 396;
248/74.1, 74.2, 74.3, 74.4
CPC . B65D 63/16; F16B 2/08; A44B 11/04; A44B
6/00; F16G 11/14; B60R 22/24
See application file for complete search history.

5,316,246	A *	5/1994	Scott et al.	248/68.1
D372,420	S *	8/1996	Mendez	D8/356
D376,309	S *	12/1996	Takai	D8/356
D404,580	S *	1/1999	Hasler	D6/320
D415,530	S *	10/1999	Ridder	D19/77
5,992,802	A *	11/1999	Campbell	248/68.1
6,227,502	B1 *	5/2001	Derman	248/74.4
6,360,051	B1 *	3/2002	Daoud	385/137
6,405,414	B1 *	6/2002	Byrnes	A61M 25/00
				24/339
D459,977	S *	7/2002	Byrnes et al.	D8/357
6,415,932	B1 *	7/2002	Fiscus et al.	211/64
6,458,104	B2 *	10/2002	Gautsche	604/179

(Continued)

Primary Examiner — Cynthia R Underwood

(74) *Attorney, Agent, or Firm* — Kaplan Breyer Schwarz,
LLP

- (56) **References Cited**
U.S. PATENT DOCUMENTS
577,220 A * 2/1897 Whitehead B25J 1/04
294/209
D247,345 S * 2/1978 Mulholland D2/607
4,114,241 A * 9/1978 Bisping 403/188
D256,303 S * 8/1980 Rieman D6/552
4,244,544 A * 1/1981 Kornat 248/68.1
D272,785 S * 2/1984 Rumbaugh D6/552
D272,787 S * 2/1984 Rumbaugh D6/552
4,971,271 A * 11/1990 Sularz 248/68.1

(57) **CLAIM**

The ornamental design for a linear double track rail, as shown and described.

DESCRIPTION

FIG. 1 is a top plan view of a linear double track rail showing our new design;
 FIG. 2 is bottom plan view of the linear double track rail of FIG. 1;
 FIG. 3 is a front elevation view of the linear double track rail of FIG. 1;
 FIG. 4 is a rear elevation view of the linear double track rail of FIG. 1;
 FIG. 5 is a left side elevation view of the linear double track rail of FIG. 1;
 FIG. 6 is a right side elevation view of the linear double track rail of FIG. 1; and,
 FIG. 7 is an isometric view of the linear double track rail of FIG. 1.
 The appearance of any portion of the linear double track rail between the break lines forms no part of the claimed design.

1 Claim, 7 Drawing Sheets

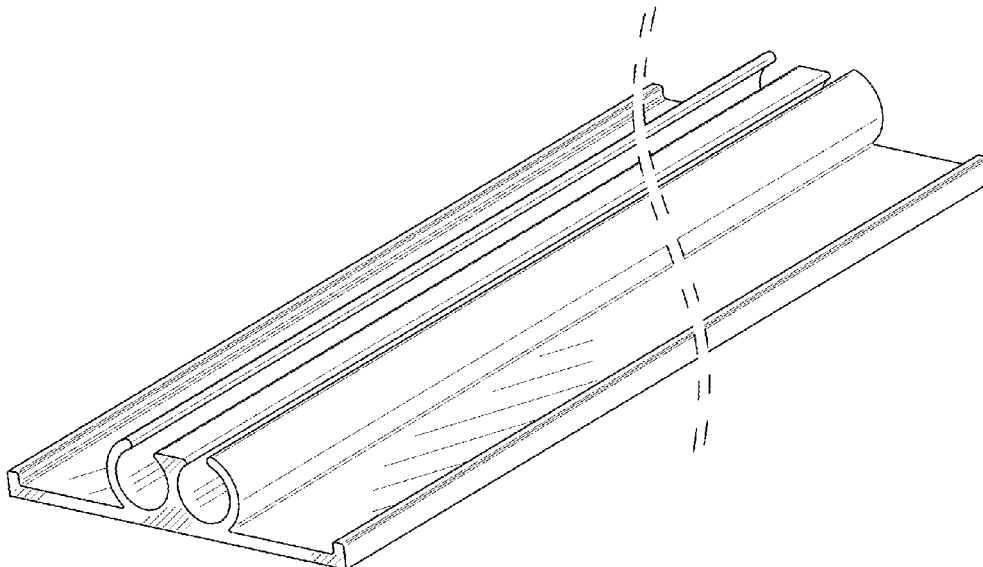

(56)

References Cited

U.S. PATENT DOCUMENTS

D485,161	S *	1/2004	Hutchinson	D8/383	8,056,680	B2 *	11/2011	Broten	182/221
D488,054	S *	4/2004	Myers	D8/356	D668,130	S *	10/2012	Pawluk	D8/356
D494,450	S *	8/2004	Schultz	D8/356	D676,310	S *	2/2013	Lowrance	D8/356
D534,065	S *	12/2006	Andre	D8/395	D691,875	S *	10/2013	Ganski	D8/356
H2203	H *	10/2007	Borchardt et al.	D8/396	D691,878	S *	10/2013	Ganski	D8/356
7,314,142	B2 *	1/2008	Lyman, Jr.	B43K 23/002	D702,532	S *	4/2014	Garrido et al.	D8/354
				206/214	8,900,196	B2 *	12/2014	Andino	604/174
D568,723	S *	5/2008	Morgan	D8/356	D720,606	S *	1/2015	Mathews et al.	D8/356
D577,990	S *	10/2008	Andre	D14/205	D728,349	S *	5/2015	Lake	D8/356
D580,661	S *	11/2008	Belokin	D6/315	D752,955	S *	4/2016	Rowan	D8/356
D586,567	S *	2/2009	Heroux	D6/323	D775,937	S *	1/2017	Davis	D8/356
D587,101	S *	2/2009	Morgan	D8/356	D786,048	S *	5/2017	Grewal	F16G 11/14
D587,102	S *	2/2009	Morgan	D8/356					D8/356
7,500,644	B2 *	3/2009	Naudet et al.	248/68.1	D843,131	S *	3/2019	Chou	D6/580
D606,323	S *	12/2009	Heroux	D6/323	D852,354	S *	6/2019	Wrangmark	D24/128
7,712,709	B2 *	5/2010	Winchester	248/89	D877,899	S *	3/2020	Shepherd	D24/128
D629,803	S *	12/2010	St. Ives	D14/396	D881,823	S *	4/2020	Clowes	D13/155
D638,690	S *	5/2011	Hoek	D8/356	D886,991	S *	6/2020	Kindler	D24/128
D638,691	S *	5/2011	Hoek	D8/356	D886,993	S *	6/2020	Dwyer	D24/128
D638,692	S *	5/2011	Hoek	D8/356	D896,955	S *	9/2020	Wiechman	D24/128
D640,527	S *	6/2011	Hoek	D8/356	2003/0132352	A1 *	7/2003	Weaver	248/68.1
D648,685	S *	11/2011	Symons	D13/155	2005/0189453	A1 *	9/2005	DeGuevara	248/68.1
						2010/0024993	A1 *	2/2010	Chou	E06B 9/50
										160/323.1
						2010/0132979	A1 *	6/2010	Chen	174/135

* cited by examiner

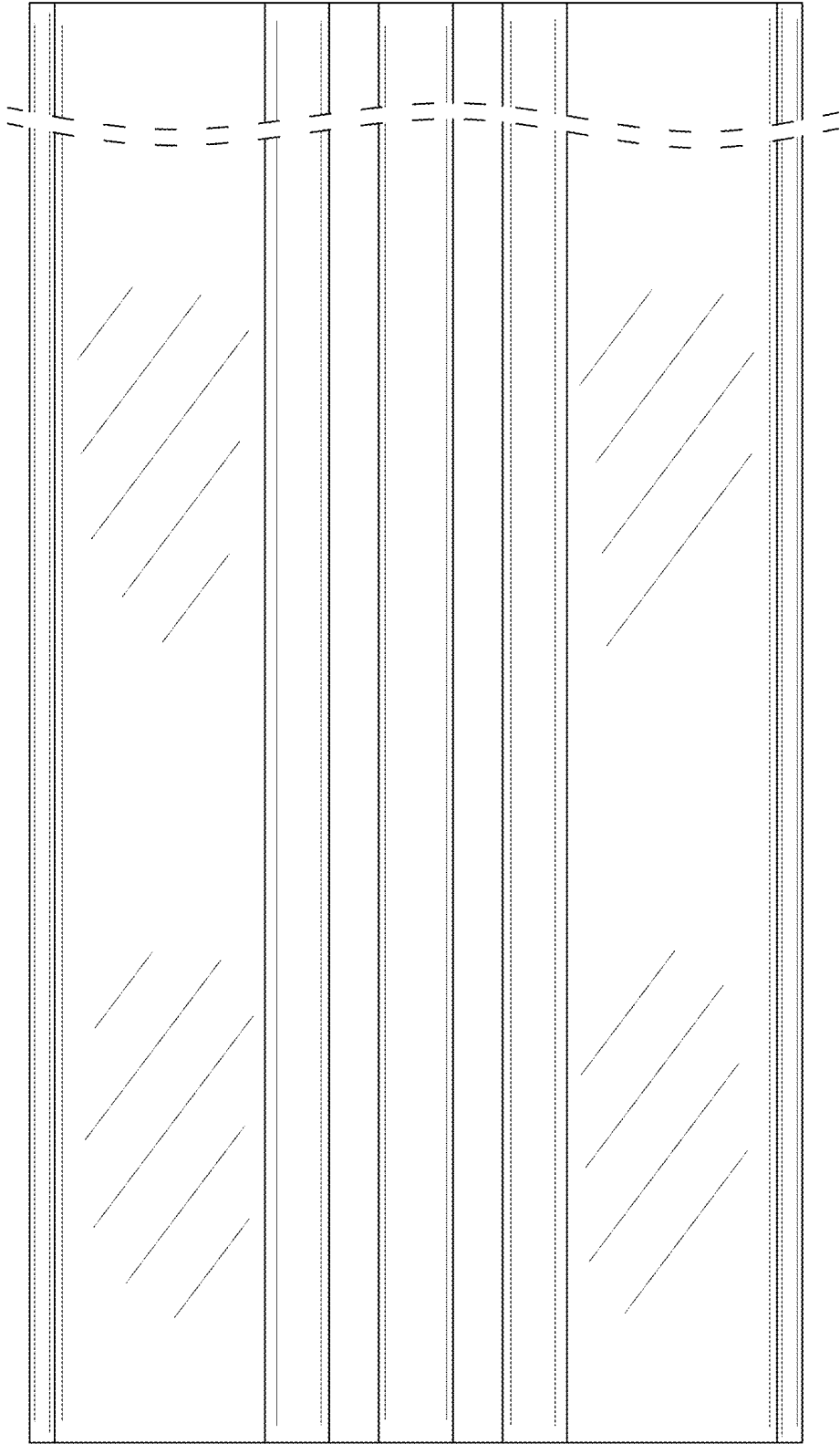

FIG. 1

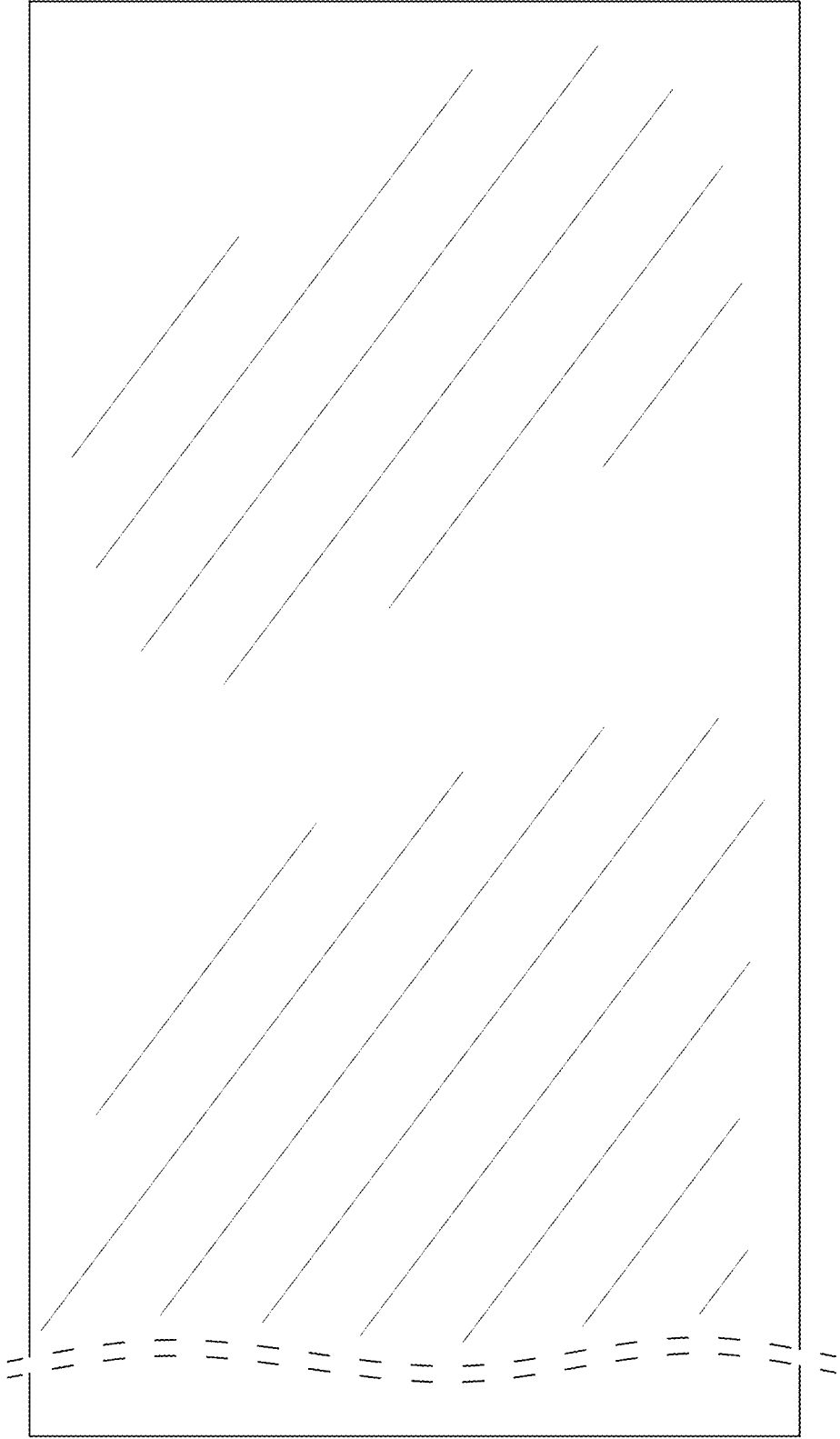

FIG. 2

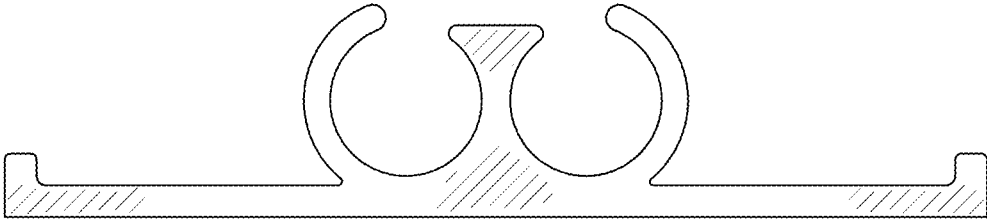

FIG. 3

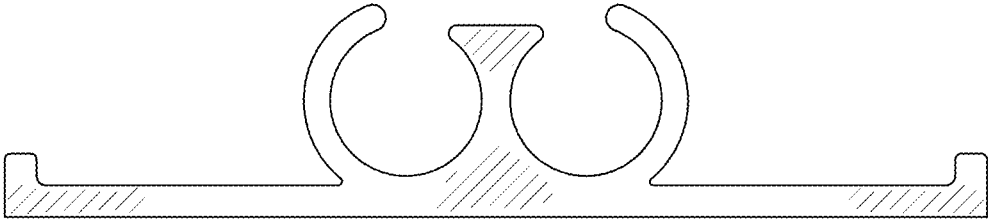

FIG. 4

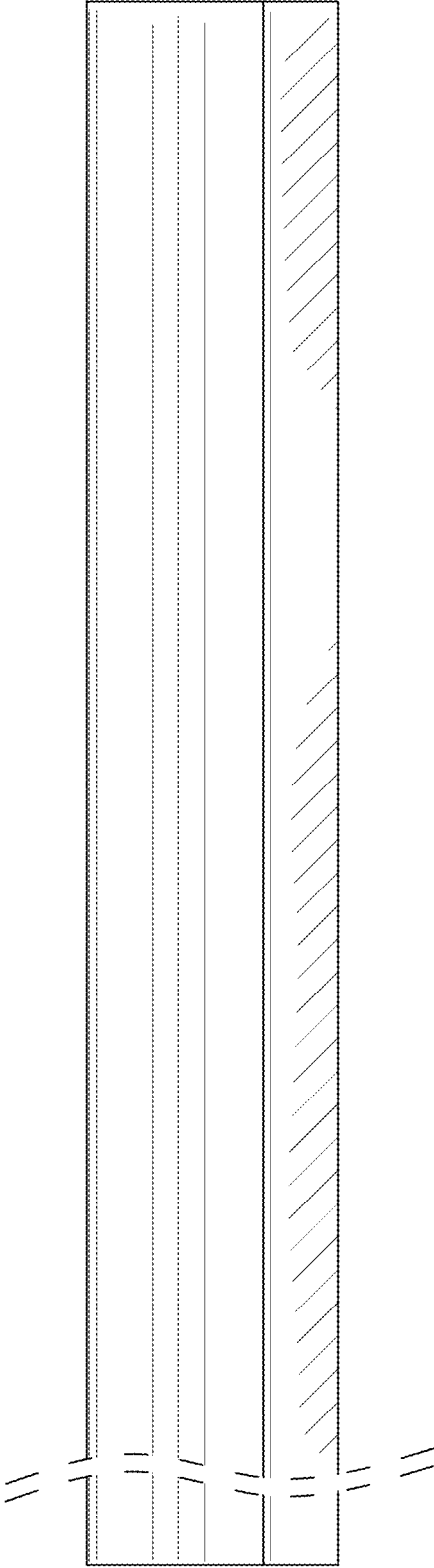

FIG. 5

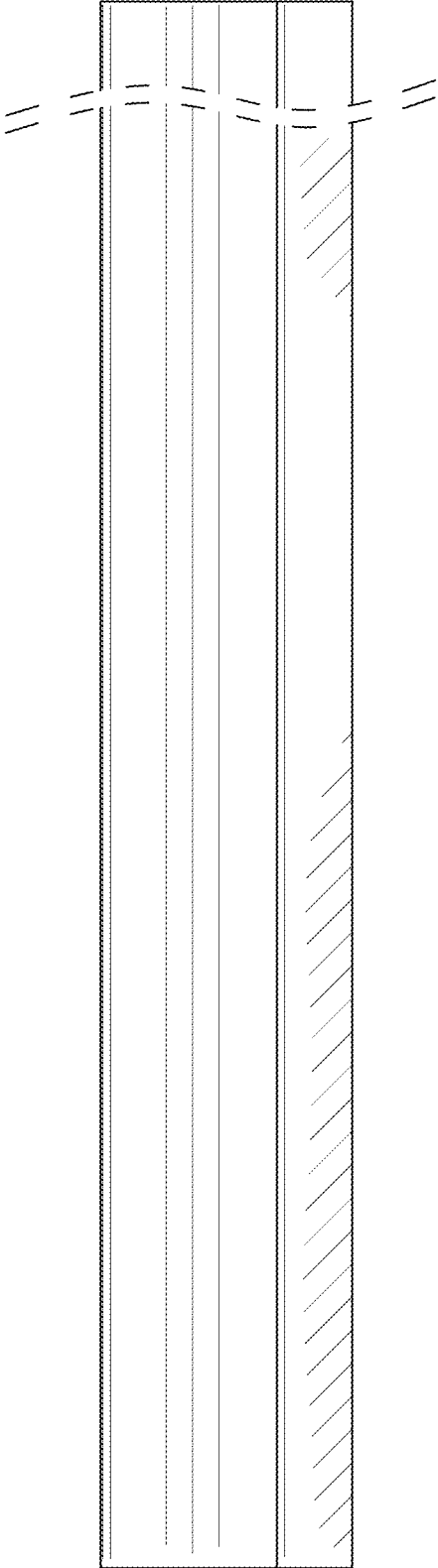

FIG. 6

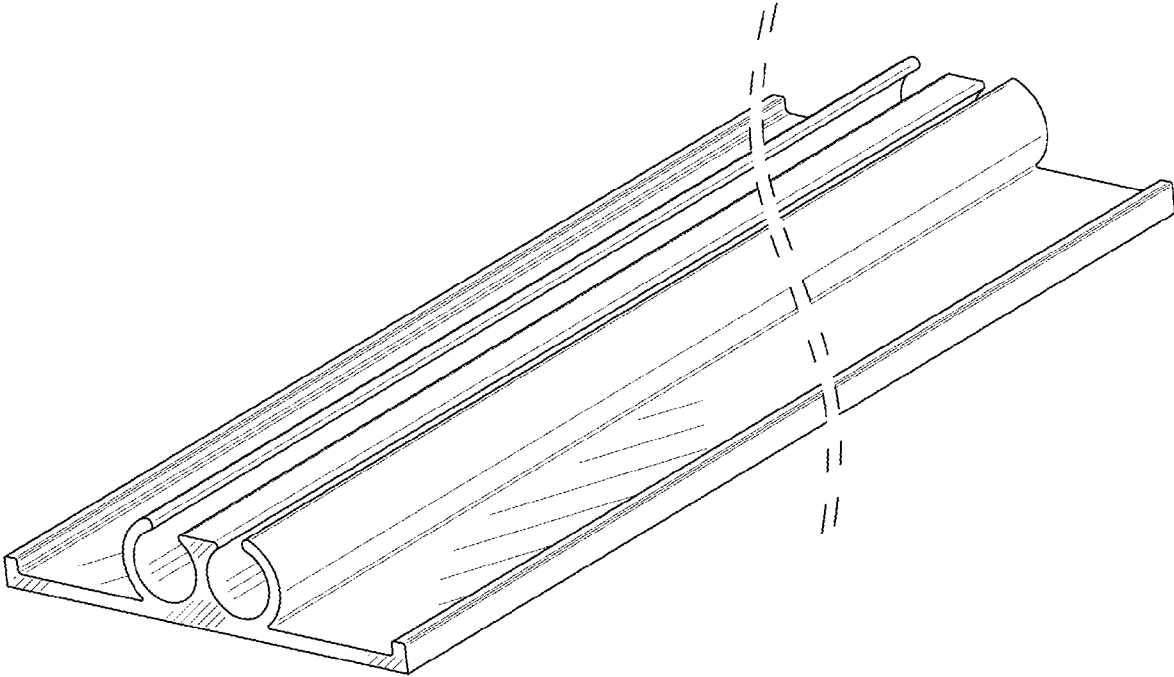

FIG. 7