

[54] **UNDER-WATER SPRAYING**  
 [75] Inventors: **Nicholas Norbert Tusch, London; Robert Ian Watson, Blackburn; Jack Taylor, Accrington, all of England**  
 [73] Assignee: **Colebrand Limited, London, England**  
 [22] Filed: **Aug. 27, 1973**  
 [21] Appl. No.: **391,714**

**Related U.S. Application Data**

[62] Division of Ser. No. 174,445, Aug. 24, 1971, Pat. No. 3,788,273.  
 [52] U.S. Cl. .... **117/104 R, 29/81 K, 114/222**  
 [51] Int. Cl. .... **B05c 5/02**  
 [58] Field of Search..... 114/222, 221 R; 15/322, 15/1.7; 29/81 B, 81 K, 81 C; 117/104 R, 127; 118/50, 305, 207; 134/37, 198, 199; 51/11, 319; 239/290, 288.5

**References Cited**

**UNITED STATES PATENTS**

1,079,208	11/1913	Browne.....	114/222
3,256,642	6/1966	Fonti.....	51/11
3,526,362	9/1970	Jackson .....	239/290

3,609,916	10/1971	Hammelmann.....	114/222
3,766,879	10/1973	Jones.....	114/222

**FOREIGN PATENTS OR APPLICATIONS**

1,454,007	10/1965	France.....	114/222
-----------	---------	-------------	---------

*Primary Examiner*—George E. A. Halvosa  
*Assistant Examiner*—Charles E. Frankfort  
*Attorney, Agent, or Firm*—Allison C. Collard

[57] **ABSTRACT**

The described invention relates to a method and apparatus for applying paint or the like to a submerged surface and includes the provision of a hollow shield with an elongated opening which shield is purged of water by compressed air the resultant airfilled space being traversed by a sheet-like spray of the paint supplied from atomising means and formed so as to be substantially uninterrupted by the internal wall of the shield. Various systems are described by way of elaboration of the actual margin of the shield to accommodate different surfaces; to provide for maintaining appropriate spacing between the margin of the shield and the surface and for affording mobility of the whole apparatus.

**14 Claims, 12 Drawing Figures**

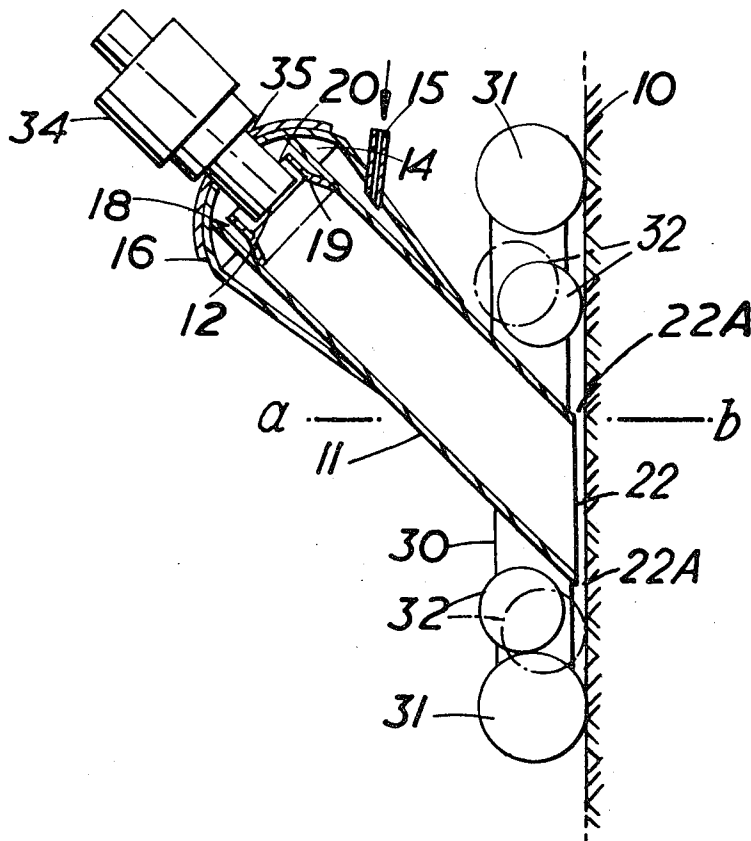

FIG. 1.

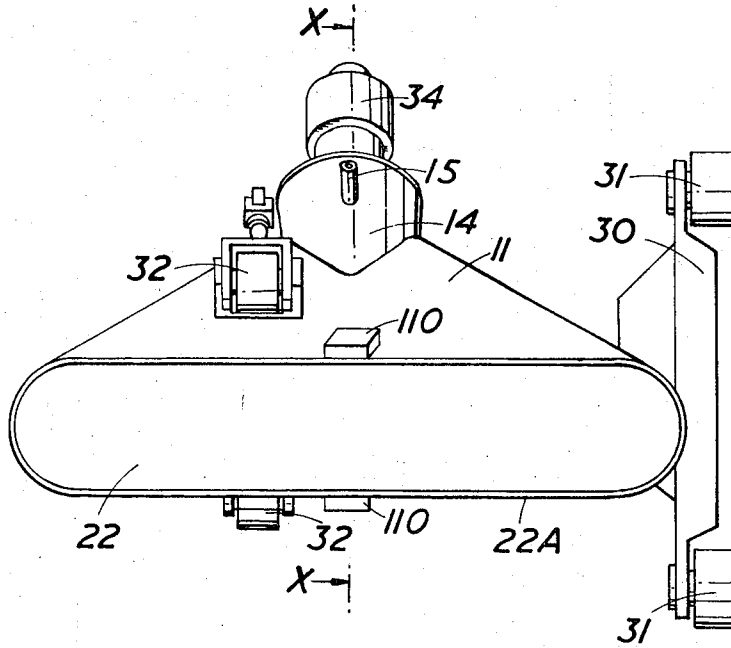

FIG. 2.

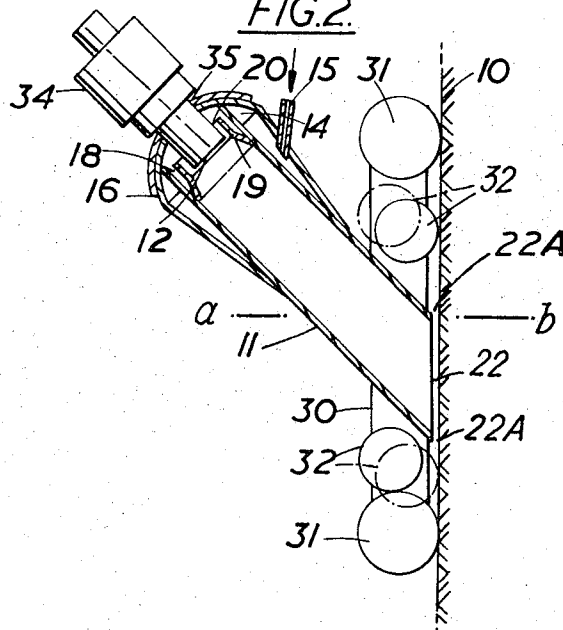

FIG. 3.

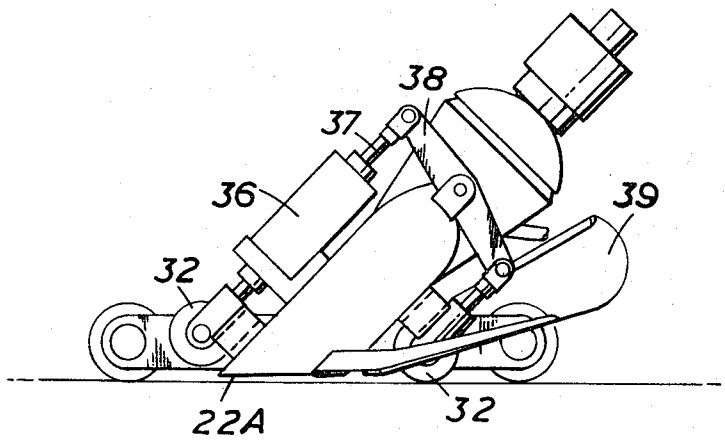
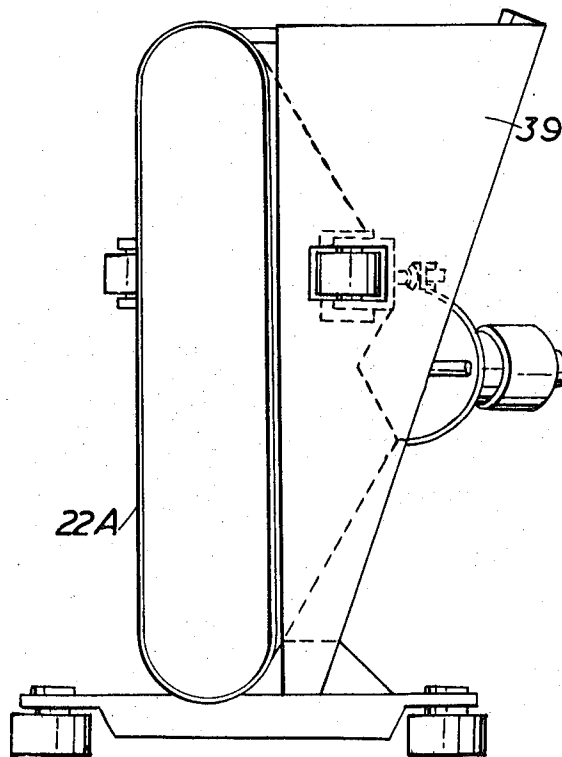

FIG. 4.



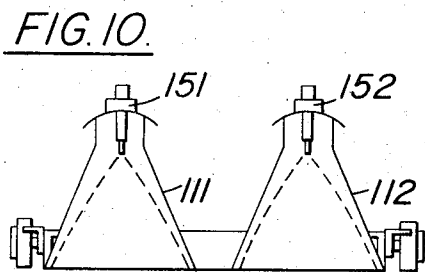
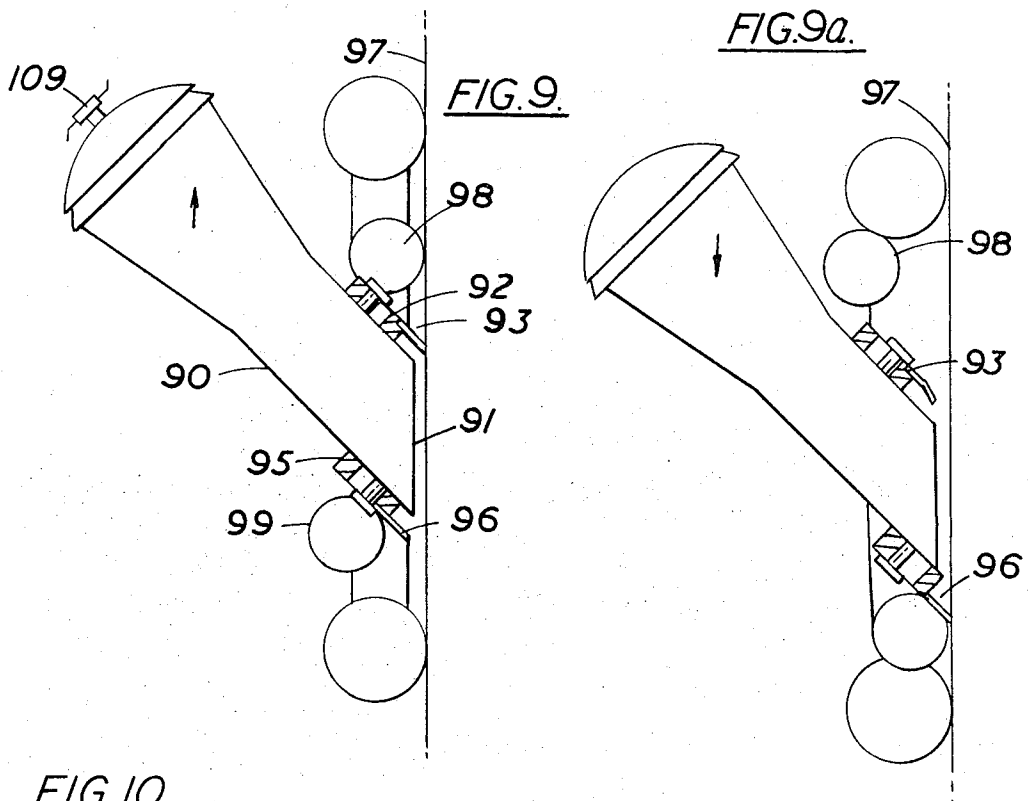
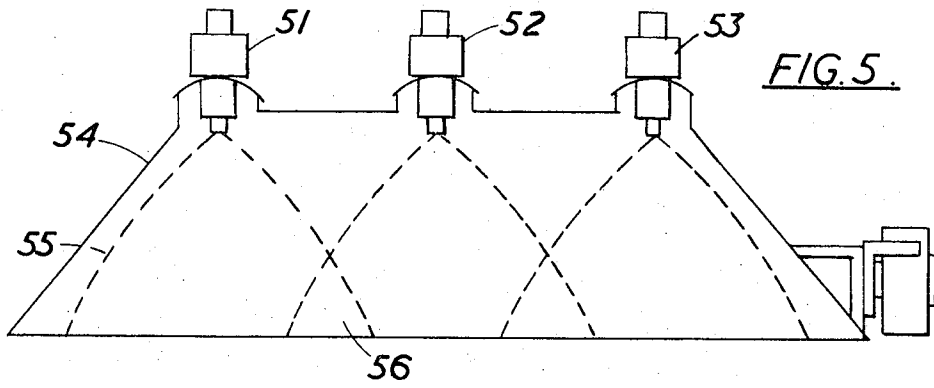

FIG. 6.

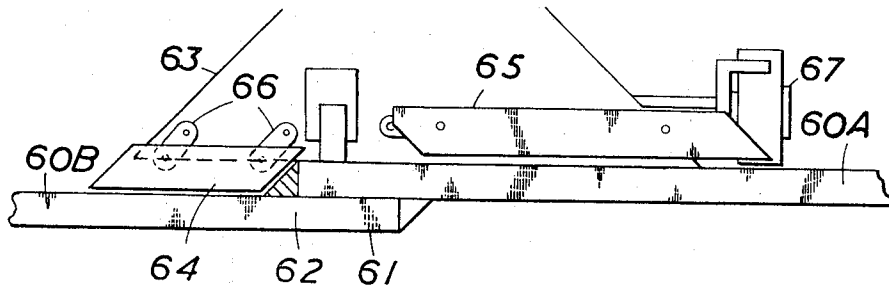

FIG. 6a.

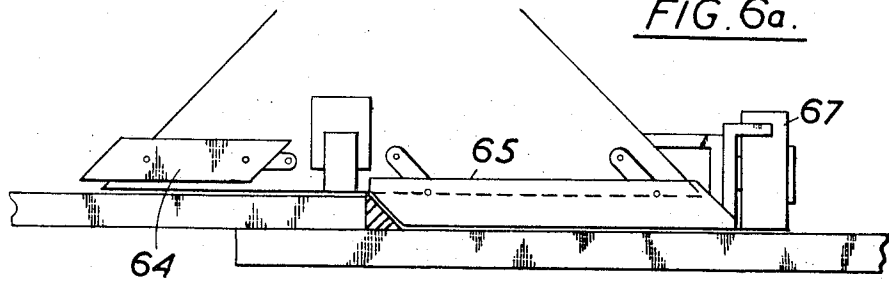

FIG. 7.

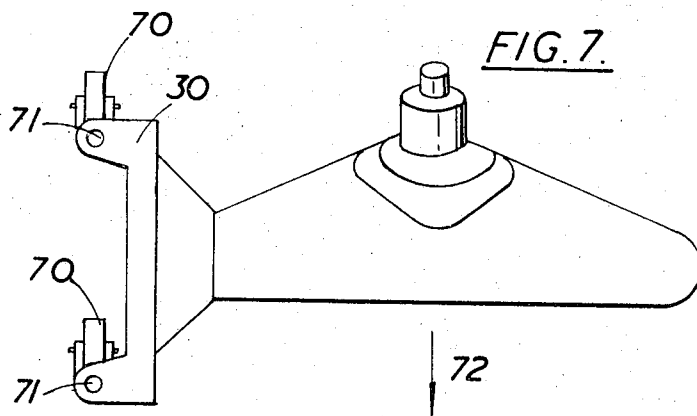
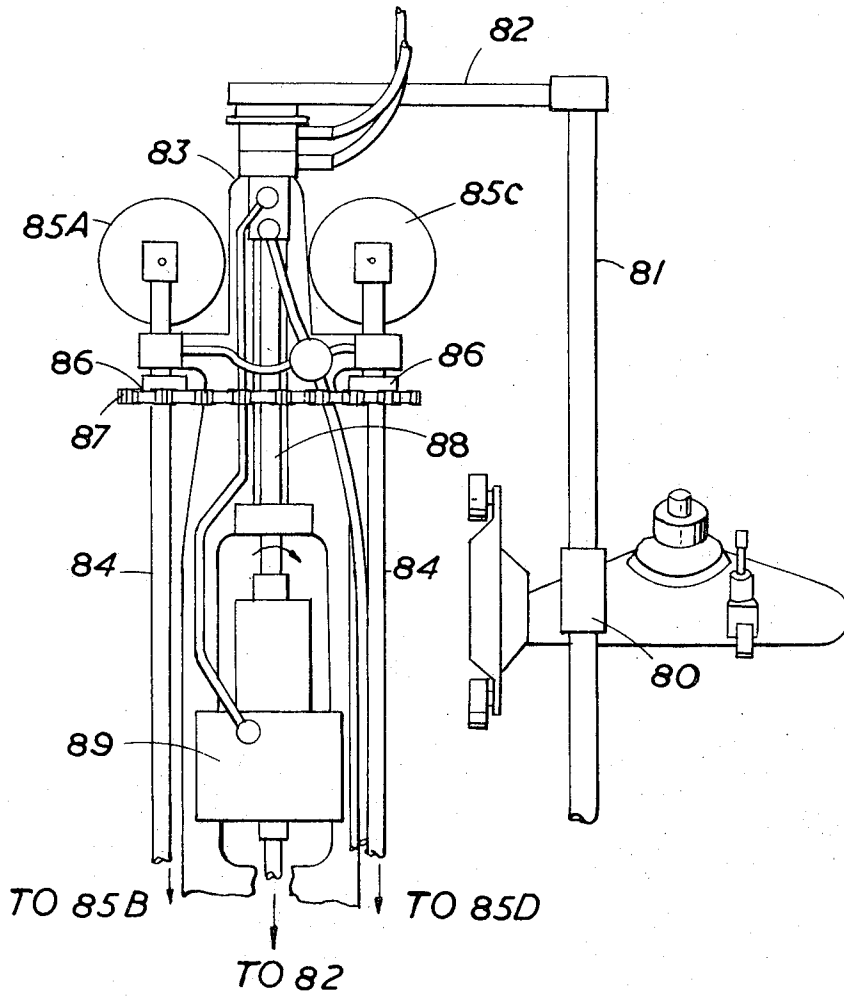

FIG. 8.



**UNDER-WATER SPRAYING**

This is a division of application Ser. No. 174,445 filed Aug. 24, 1971 now issued as U.S. Pat. No. 3,788,273.

This invention relates to a method of applying paint or like liquid to a surface which is submerged, and the apparatus used to practise the method. The invention is primarily intended to be used in the painting of, or application of a liquid in paint-like manner to, the hull of a ship or any other submerged surface which is normally inaccessible except to a diver. Particularly in the case of modern very large ships for which docking facilities are not easily available they nevertheless require to be treated with compositions such as for corrosion or fouling protection from time to time. There are also instances when it is required to apply similar substances to the submerged part of a sea-wall or like fixed structure, or to moored buoys.

The invention is entirely concerned with spray painting, or equivalent application (which we will refer to for brevity as painting) that is to say painting by the projection or droplets of the paint with considerable velocity to impact the surface upon which the droplets then coalesce to form a uniform film. It has been proposed previously to use as an applicator a bell-like shield enclosing a spraying nozzle and to purge the interior of the bell by compressed air so that the paint can pass relatively freely through air in the bell finally reaching the surface. In such prior proposals, however, it does not seem to have been thought practicable to apply the foregoing general idea in an economic and sensible manner and, which is more important, to cover the required surface area quickly by painting in a relatively broad swath or band by just one passage of the spray. If a circular shield be used as previously proposed, the length of its margin (i.e. the linear dimension) is unnecessarily great in proportion to the enclosed volume of the shield, so that the maximum leakage of air, and therefore the maximum consumption of air, can occur. The present invention seeks to economise in air to be supplied and as a secondary advantage of such economy, to diminish the cloud of bubbles which inevitably escape and can impede the operator's view of his work. A major advantage of the present invention therefore resides in its economy and convenience of operation.

The invention also makes use of various practical expedients which may or may not be applied according to the scale of the operation. For example, if large and heavy spraying apparatus is to be used as might be the case for very large ships' sides, the invention provides for means to secure the apparatus to the surface to be treated in such a manner that it can easily be moved, and also so that in any one attached position a considerable area may be painted. Again, if the apparatus is to be hand-held means are provided by the invention whereby it can easily be moved about over the surface. yet again, since it is required to control with considerable exactness the gap between the shield and the surface through which gap the air is to escape, the invention provides means for maintaining and controlling the gap. Since such means involve contact between the surface and parts which move over the surface, the invention provides that such contact is avoided in the area which has just been painted so that the newly applied paint is not disturbed. The means for effecting this according to the invention are reversible so that change of sense of direction of the painting operation is pro-

vided for. The invention affords other practical devices which have been found to be advantageous in some cases of submerged painting operations. The invention is in the first instance intended to be practised by a diver operator but it will not require very much elaboration to enable it to be used as a fully automatic applicator device.

Basically then, the invention resides in a method of coating a submerged surface by spraying with a liquid, in which there is passed over the surface the margin of an opening which is of relatively short dimension in the direction of such passage and of relatively long dimension in the direction across such passage, maintaining the margin so that at least its trailing edge (i.e. that of longer dimension which, in relation to the sense of direction of passage, is behind the other) is spaced from the surface by a gap which leads from the opening of an otherwise watertight hollow shield; supplying into the shield compressed air at a sufficient pressure and rate to keep the interior of the shield purged of water whilst there is air escape through the gap, and projecting the liquid to the surface from a source which is inside the shield and spaced from the surface as a spray of droplets in a sheet-like pattern corresponding in short and long dimensions to the opening but smaller, the velocity of projection of the droplets and their mass being such that they or at least a majority of them penetrate the volume of intervening air maintained within the shield and such film of water as there may be on the surface so as to reach the surface and form thereon a continuous film.

The invention further includes the elaboration of the foregoing method by various other steps as defined in the claims herewith.

The invention also includes apparatus for performing the above method and its variations. In particular, apparatus for painting a submerged surface comprises a hollow, watertight shield of a shape which, in a cross-section, extends from the location of a spray jet to an opening which is of considerably greater length than breadth, the length being transverse to the intended direction of passage for painting, and the spray jet is of any suitable known kind from which is ejected a spray of droplets of a flat or sheet-like character; and the shape of the shield is such as to surround this spray so as effectively not to obstruct the spray. Further features of the apparatus will become clear from the following descriptions and from the subject of Claims.

In applying the invention it is preferred to use a spray of purely hydraulic type, that is to say an airless spray in which the paint is delivered at a high pressure and from which the paint emerges at very high velocity and breaks up into droplets after emerging. It is, however, possible to use an air type spray but in such case the air which, as will be seen below, is used to purge the shield of water, will probably have to have a certain velocity itself, so as not to impede the action of the airspray. Yet again it is possible to make use of electrostatic spraying providing that the interior surface of the shield is electrically isolated from the paint source either by virtue of an insulating coating or by an insulating separator between the gun and the shield thus preventing the spray being attracted to the shield instead of to the surface to be painted. For various reasons of convenience however, the invention is primarily concerned with simple hydraulic spray means and there are many variations of appropriate spray nozzles on the market which

produce the required spray pattern in the form of a thin sheet: as will be seen, the spray means may consist of a plurality of aligned spray nozzles collectively delivering a sheet of spray particles.

Apparatus according to the invention, with comments on its use, will now be described by reference to the accompanying drawings in which:

FIG. 1 is a plan view of the so-called spray gun constituting the effective apparatus.

FIG. 2 is a part section on the line X—X in FIG. 1, FIG. 3 is an end elevation (from the same aspect as FIG. 2) of the spray gun shown in greater detail and

FIG. 4 is a plan view of the gun as shown in FIG. 3 illustrating a modification intended to prevent bubbles from obscuring the diver's view.

FIG. 5 is a sketch illustration showing a plurality of aligned spray nozzles.

FIGS. 6 and 6a are diagrams of another modification of the shield, to deal with certain types of surface e.g. where the surface is of steel sheets with lap joints.

FIG. 7 illustrates how castoring wheels may be used.

FIG. 8 is an illustration of a way of moving the spray gun over the surface in a mechanised manner.

FIGS. 9 and 9A are diagrams to show an elaboration of the shield to economise in air and reduce bubbling.

FIG. 10 discloses a plurality of shields each with spray nozzle and air supply means.

The gun forming the subject of this example is intended for use in spray painting under water of substantially vertical surfaces (indicated at 10 in FIG. 2), such as the sides of a ship. This gun in its simplest form, is intended to be hand-held and passed up and down the surface to be painted, traversed transversely at the end of the up stroke, passed through a down stroke, again traversed, and so on.

The gun comprises a hollow shield 11 of generally fish-tail shape and internally provided with a spray nozzle 12 at the closed, narrow, end of the shield. This nozzle is of a known type such as to produce by airless atomisation, a divergent sheet-like spray of droplets conforming to the shape of the shield but sufficiently smaller in cross section to substantially avoid coating the internal surfaces of the shield. These surfaces are preferably covered with P.T.F.E. as a further precaution against lodging of the paint on the surfaces or to make easier the removal of any paint which has fouled the interior of the shield. Surrounding the closed end of the shield is a chamber 14 with an inlet 15 for compressed air. Perforations 16 in the wall of the shield lead from the chamber 14 to an inner chamber 18 defined by a baffle 19. There is an annular gap 20 between the baffle 19 and the housing for the nozzle 12 so that the air flow passes from the chambers 14 and 18 into the shield around the spray jet and out of the opening 22 of the shield, which opening is narrow in the direction of intended passage and comparatively wide across such direction. The air supply arrangement is intended to admit the air into the shield without disturbing the spray pattern.

The margin 22A of the mouth 22 lies in a plane making an angle of about 45° with the axis of the nozzle 12 and, in use, is spaced at a small distance from the surface 10 to be sprayed. Provision is made, as will be seen, to enable this distance to be adjusted to an optimum for the particular surface being sprayed. When the nozzle axis lies in a vertical plane and at an angle of about 45° to the surface 10, the greater dimension

of the mouth 22 then lies horizontally, the lesser dimension  $h$  (FIG. 1) then lying in the intended direction of movement of the gun. The rate and pressure of air supply into the shield is maintained at a value sufficiently above the pressure of the ambient water to purge the shield of water and keep it purged, so to expose the area of the surface 10 within the margin 22A for painting. It is an advantage of the construction described, however, that if for any reason water enters the shield (e.g. because the gun runs off the surface being painted) or the air is interrupted, it will only do so to the level  $a-b$  (FIG. 2) and the volume of water to be removed at the re-start of work will be small. In that sense the shield acts as a "diving bell."

The gun is mounted on a carriage 30, only partly shown in the drawings. This carriage has two wheels 31 at one side of the mouth 22 which run on unpainted parts of the surface 10 to the side of the mouth 22. In addition there are two wheels 32 which lie within the width of mouth 22 and are alternatively engageable as shown in FIG. 3 by means of a double acting pneumatic ram 36, the piston rod 37 of which is connected directly to the mounting for one wheel 32 and through a rocker 38 pivoted on the shield to the mounting for the other wheel. When the gun is moving upwardly the upper wheel is engaged with the unpainted part of surface 10 as shown and the lower wheel 32 is held off the newly painted area of the surface. Conversely when the gun is moving downwardly the upper wheel is held off the surface and the lower wheel engages the surface. The line of the force with which the spray gun is applied to the surface lies within the triangle formed by the contact points of the three wheels, thus giving a stable arrangement.

The carriage may also be provided with a propeller (not shown) which rotates about an axis perpendicular to surface 10 and so produces a thrust tending to maintain the wheels 31, 32 in contact with the surface and hence maintain the mouth of the shield at its desired distance from the surface being sprayed.

The propeller and, for traction, the wheels 31 (and/or 32) may be driven by electricity, compressed air or hydraulically, the same power source being used for both, if desired. Preferably the drive to the traction wheels, if provided, is reversible. The speed at which the wheels and/or the propeller are driven may be variable and means may be provided to maintain the speed at a predetermined value.

The nozzle 12 is mounted in a housing 34 providing a feed conduit for the paint. This housing is mounted on the shield by way of a part spherical bearing 35 which enables the direction of the spray within the shield to be adjusted so that the spray may be caused to lie centrally in the margin of the shield.

Means such as an interconnection between a paint supply valve and the pressure of the ram 36 may be provided for automatically cutting off the supply of paint during periods in which the direction of movement of the gun is being reversed and wheels 32 changed over.

There may be a regulator for the air pressure within or attached to the shield. This may comprise a diaphragm (or equivalent piston) open on one side to the ambient water pressure and operable to maintain the air pressure within the shield at a pre-set value above the ambient pressure.

It is to be appreciated that by employing a high ratio of width to height ( $h$ ) of the opening 22 not only is a relatively wide strip painted at each up or down traverse of the gun but also the difference in water pressure at the upper and lower edges of the mouth is reduced to a minimum which assists in maintaining displacement of the water with a minimum of expenditure of air. It is also an advantage that the mouth of the shield may be held close to the surface being painted which reduces the consumption of air. However, a major advantage of keeping the lesser dimension ( $h$ ) of the opening as small as is practicable is that this affords the least possible length (in linear terms) of margin 22A in relation to the contained volume in the shield, thus affording the least possible leakage-path for the air.

It is within the invention to provide a deflector 39 as shown in FIG. 4 above the mouth of the shield, to be held close to the surface being painted and sloped or shaped to divert to one side (or both sides) air bubbling up from the shield mouth, hence to reduce obstruction by the bubbles to visual inspection of the surface which has been, or is about to be, painted.

Also, one or more scrubbers may be provided to scrub the surface prior to application of paint. The scrubbers may be separate from or embodied in the gun. These may be rotary brushes, driven by electricity, compressed air or hydraulically, and there may also be provided means for feeding at a controllable rate a wetting agent or other cleaning material through the centre of the brush.

In FIG. 5 it is shown that three separate nozzles 51, 52 and 53 are used within one shield 54. In such a case the actual shape of the shield may be modified somewhat in the manner drawn so as to accommodate the three droplet sprays indicated approximately in dotted line at 55. The sprays will be so positioned and the pattern of their tips so selected that they overlap as at 56; this, if appropriately selected, will not result in any undue concentration of paint in the zone 56 because the extreme margins of the divergent spray are in any case somewhat attenuated as compared to the main part of the spray. It will be clear from this illustration that any reasonable number of nozzles may be used, the breadth to length proportion of the opening of the shield 54 of course being appropriately varied. Moreover, instead of putting several spray nozzles, within one shield the apparatus may involve the provision of several complete units of shield plus nozzle and these may be arranged in somewhat staggered relationship so that one passage of the group of shields produces a uniform swath of paint.

FIGS. 6 and 6A illustrate a device which copes with a particular problem encountered in painting some ships hulls or like structures. The device is one which adapts a shield to conform reasonably well with a certain type of contour of surface. The same device enables a flat surface to be painted. In FIG. 6 the surface to be painted is broken up into an area 60A and a second area 60B these being supposed to be interconnected by a lap joint 61 probably by welding at 62. The shield 63 of the apparatus has at the margin of its opening two parts, 64 and 65 which are attached to the shield 63 by parallel links such as 66. Each of these parts can be swung by virtue of the parallel links so that, for example, the part 64 being swung the shield opening has its effective margin now shaped so as sub-

stantially to match the form of the weld 62. The operator will of course move either 64 or 65 into the appropriate position for the particular circumstance encountered, in other words as is seen in FIG. 6A, he can select the "hand" of operation. In FIG. 6A the part 65 is swung, part 64 being in the retracted position. Mechanism not shown in the drawing may be provided in any suitable form to advance a guide wheel 67 to maintain the shield parallel to the surfaces being painted. The shield is conditioned for normal use on a flat surface by retracting both parts 64 and 65 and placing the wheel 67 in the position to produce a small and uniform gap between the margin of the shield and the surface being painted. Similar provision, i.e. movable margin elements, may be used to facilitate operation over lines of rivets or similar excrescences.

Moving now to FIG. 7, it is indicated diagrammatically how the carriage, which is to be seen more fully in FIGS. 1-4 and its side running wheels can be arranged so that the operator can more readily traverse the apparatus from one completed path to a second adjacent parallel path, or to accommodate his operation to various surfaces or around obstacles. In this Figure, 30 again indicates the side part of the carriage and the two wheels (31 in previous Figures) are now indicated at 70 and they are mounted like furniture castors on pivotal axes 71 providing for 360° directional orientation of the wheels 70. The wheels 32 (earlier Figures) not shown in FIG. 7, will likewise be mounted for castoring. In FIG. 7 the wheels 70 are shown trailing thus indicating that the apparatus is moving in the direction of the arrow 72.

FIG. 8 shows one way in which the apparatus of any previous Figure can be mounted so that it is held against the surface to be painted and so that the gun as a whole may be manipulated with considerable facility over a wide area, both as to vertical and horizontal passage over the surface. The gun is attached to the structure of FIG. 8 by means of a bush 80 which slides on a rod 81. The gun is caused to traverse the rod 81 by an air motor, omitted from the drawing for simplicity, spraying a swath of paint as it does so. The rod 81 is attached to two radius arms 82 (only one of which is shown) which are connected by journals to the frame 83 which also carries, in bearings, the two shafts 84. Attached to the ends of the shafts 84 are vacuum cups 85 (only two of which are shown). A bearing movement is imparted via a shaft 88 to the radius arms 82 by means of a pneumatic motor 89, the torque reaction being transmitted from the motor casing to the frame 83.

In operation the device is placed on the surface to be painted and all four vacuum cups 85 evacuated causing them to adhere strongly to the surface. A torque is produced by the motor 89 in the arrowed direction and in consequence the spray gun is pressed against the surface. The gun is caused to traverse the length of the rod 81 and come to rest at one end. If the vacuum is released from vacuum cups 85C and 85D whilst torque is maintained by the motor, the frame 83 will, because of torque reaction rotate about the shaft 88 and will so to speak, take one 'step' to the left (of the Figure). Re-evacuating cups 85C and 85D will once more cause the device to be held rigidly to the surface and the movement of the spray gun restarted. The sprockets 86 and chain 87 cause the two vacuum cups which are taking the step to present their openings squarely to the sur-

face. By repetitive functioning of the vacuum system the device may be made to 'make' along the surface to be painted.

The radius arms **82** may be in the form of a toggle linkage and may thus permit the rod **81** to be angled in respect to the frame **83** and in consequence may give improved mobility to the gun.

The whole of this device may be controlled both as to suction and stepping by any suitable type of pilot or electrically operated valves.

Although this method of temporary attachment of the gun apparatus to the surface to be painted is given by way of example, it is to be understood that various other expedients may be used. We have previously mentioned the possibility of using a propeller-like device **109** as shown in FIG. 9. Permanent or electromagnets **110** as shown in FIG. 1 may be used where the surface to be painted is for example of mild steel.

Turning now to FIGS. 9 and 9A, a variant is illustrated which is in its turn capable of being very considerably changed. In essence its purpose is first to economise in the required airflow and secondarily to reduce the amount of bubbling which may inconvenience the operator; further the device may have some use in removing loose particles from the surface about to be painted. There is indicated a shield **90** with the margin of its opening at **91**. On a sliding bar such as at **92** which is mounted parallel with the long dimension of the margin **91**, there is mounted a flexible strip **93** which may be formed of bristles or of a resilient material. Along the other dimension of the margin **91** is a similar bar and strip, **95** and **96**. The bars **92** and **95**, can be moved on their guides and thus bring the strips **93** and **96** into contact with the surface **97** to be painted. When the spray is being moved upwards as indicated by the arrow in FIG. 9 the strip **93** is moved into a position where it acts, somewhat like a skirt of cushioncraft vehicle but actually in contact with the surface **97** and therefore sealing the leading edge of the margin **91** against outward leakage of air from the shield **90**. Alternatively in FIG. 9A when the spray is being moved downwards the strip **96** is put in contact with the surface **97**. The movements of the strips **93** and **96** are controlled in harmony with movement of a guidewheel **98** or **99** which is moved down to roll on the surface **97** according to the sense of direction of the passage of the apparatus. The wheels **98** and **99** are the equivalent of the wheels **32** in the previous Figures. It is unimportant what interconnection there is between the guidewheels and the sealing strips. By this device it will be seen that where the apparatus is being passed in one sense or the other of direction the leading edge is in effect sealed against the surface **97** whilst the trailing edge is clear. It is of course behind the leading edge that wet paint is deposited. The end portions of the shield **90** can either be left unsealed or may have extensions of the seal **93** or **96** extending partially around such ends. FIG. 10 discloses a further embodiment showing a plurality of shields **111** and **112** each with spray nozzle and air supply means **151** and **152** so as to provide a substantially uniform pattern of spray onto the surface.

The invention will have been seen to include not only a method for painting or performing like functions under-water, but also apparatus for carrying out such a method and various modifications thereof.

The paint selected to be used for underwater application by the spray apparatus should be such as to set cure or dry by chemical reaction (e.g. as in the epoxy system); solvent loss; or absorption of oxygen from the water to polymerise the film, perhaps aided by the air supplied to purge the shield. The nature of the paint itself is believed to aid penetration of the thin water film left on the surface; probably this has to do with water solubility of one or more ingredients, and flushing-off of solvents may play a part. Such features may be of account in making the selection.

We claim:

1. Method of coating a submerged surface by spraying with a liquid, comprising the steps of;

passing over the surface the margin of an opening which is of relatively short dimension in the direction of such passage and of relatively long dimension in the direction across such passage,

maintaining the margin so that at least its trailing edge of longer dimension in relation to the sense of direction of passage is spaced from the surface by a gap which leads from the opening of an otherwise water-tight hollow shield,

supplying into the shield compressed air through its inlet at a sufficient pressure and rate to keep the interior of the shield purged of water whilst escaping through the gap,

and projecting the liquid to the surface from a source which is inside the shield and spaced from the surface as a spray of droplets in a sheet-like pattern corresponding in short and long dimensions to the opening but smaller, the spray of droplets being assisted in its passage toward the opening by the compressed air,

the velocity of projection of the droplets and their mass being such that at least a majority of them penetrate the volume of intervening air maintained within the shield and such film of water as there may be on the surface so as to reach the surface and form thereon a continuous film, the gap between the surface and the margin of the opening being maintained so as to prevent water from entering the shield by the flow of compressed air passing through the gap from the shield.

2. Method according to claim 1 in which the compressed air is supplied to the interior of the shield through a passage which surrounds the source of liquid so that the general direction of air movement in the shield corresponds with that of the spray over substantially the same distance.

3. Method according to claim 1 in which the said gap is maintained by urging the shield towards the surface and limiting its position by means bearing against unsprayed area of the surface.

4. Method according to claim 3 in which the said means is adjustable so as to adjust the gap.

5. Method according to claim 3 in which the gap is maintained between the trailing edge of the shield margin and the surface at least the leading edge of the margin being of yieldable material such as to slide in relatively airtight contact on the unsprayed surface.

6. Method according to claim 3 in which the position-limiting means is changed according to the sense of direction of passage over the surface.

7. Method according to claim 3 in which the position-limiting means comprise

9

a surface-bearing device arranged to one side of the shield (as related to its passage direction) and at least two other secondary bearing devices spaced from the opening of the shield in the path of the opening,

in which method one or other of the secondary bearing devices is controllably put into operation according to the sense of direction of passage whereby the alternative of such secondary devices is out of contact with newly-sprayed surface.

8. Method according to claim 3 in which the position-limiting means include wheels which are mounted for directional orientation and in which method the wheels are orientated so as to traverse the shield from one passage track to a further parallel track.

9. Method according to claim 1 in which the shield is urged towards the surface by a thrust caused by propeller-like means.

10. Method according to claim 1 in which the shield is urged towards the surface by magnetism.

11. Method according to claim 1 in which the shield

10

is arranged and held positioned relatively to the surface so that its opening is lower than its main interior volume, so that it acts as a "diving-bell" to retain a pocket of air even if the air supply thereto is interrupted.

5 12. Method according to claim 1 in which the pressure of the air supply is controlled so as to be compatible with the depth at which the method is performed.

10 13. Method according to claim 1 in which the source inside the shield comprises a plurality of droplet-spraying nozzles spaced across the direction of passage, the liquid being supplied to such nozzles in parallel during the passage.

15 14. Method according to claim 1 in which the shield is supported by a structure held against the surface and which is adapted to traverse the shield along a first passage track, thereafter to shift the shield by a predetermined dimension in a direction transverse to said track, and to traverse the shield along a second passage track  
20 parallel to the first.

\* \* \* \* \*

25

30

35

40

45

50

55

60

65