



US 20040124504A1

(19) **United States**

(12) **Patent Application Publication**
Hsu

(10) **Pub. No.: US 2004/0124504 A1**

(43) **Pub. Date: Jul. 1, 2004**

(54) **ELECTRICALLY CONDUCTING ORGANIC
POLYMER/NANOPARTICLE COMPOSITES
AND METHODS FOR USE THEREOF**

Publication Classification

(76) Inventor: **Che-Hsiung Hsu**, Wilmington, DE
(US)

(51) **Int. Cl.⁷** **H01C 1/00**
(52) **U.S. Cl.** **257/655; 257/607; 252/512**

Correspondence Address:
**E I DU PONT DE NEMOURS AND
COMPANY
LEGAL PATENT RECORDS CENTER
BARLEY MILL PLAZA 25/1128
4417 LANCASTER PIKE
WILMINGTON, DE 19805 (US)**

(57) **ABSTRACT**

Compositions are provided comprising aqueous dispersions of electrically conducting organic polymers and a plurality of nanoparticles. Films cast from invention compositions are useful as buffer layers in electroluminescent devices, such as organic light emitting diodes (OLEDs) and electrodes for thin film field effect transistors. Buffer layers containing nanoparticles have a much lower conductivity than buffer layers without nanoparticles. In addition, when incorporated into an electroluminescent (EL) device, buffer layers according to the invention contribute to higher stress life of the EL device.

(21) Appl. No.: **10/669,422**

(22) Filed: **Sep. 24, 2003**

Related U.S. Application Data

(60) Provisional application No. 60/413,114, filed on Sep. 24, 2002.

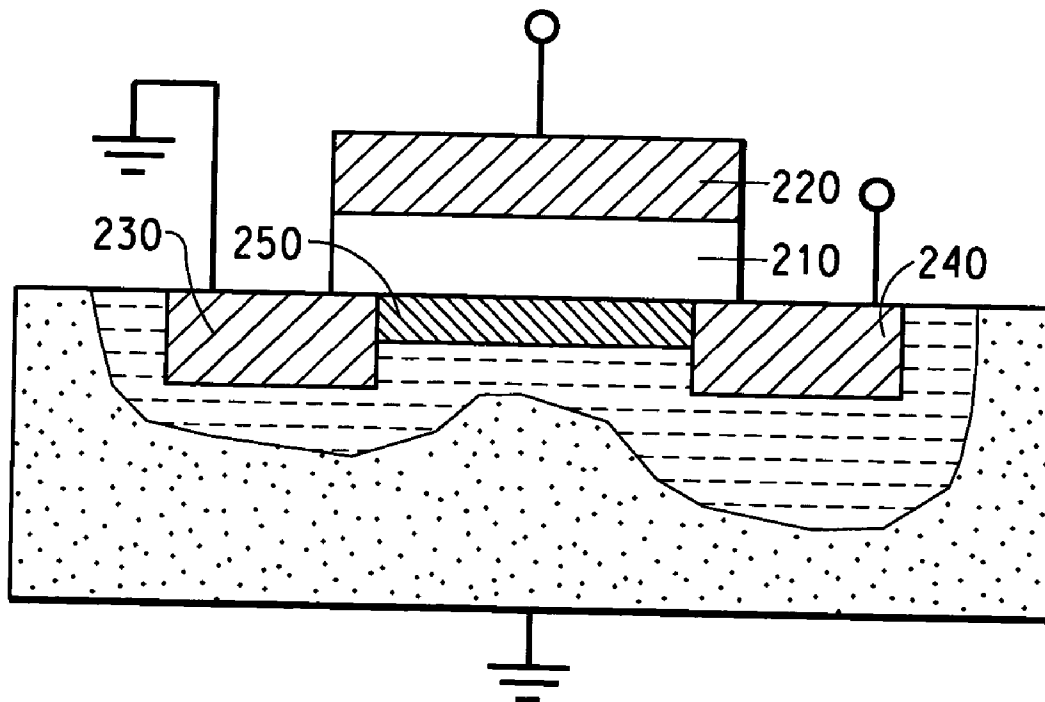

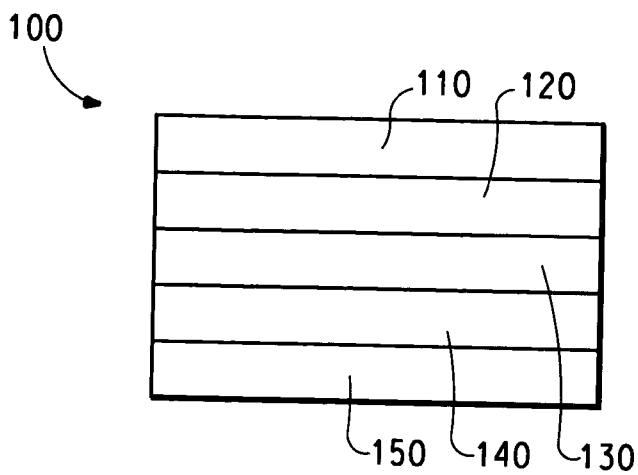

FIG. 1

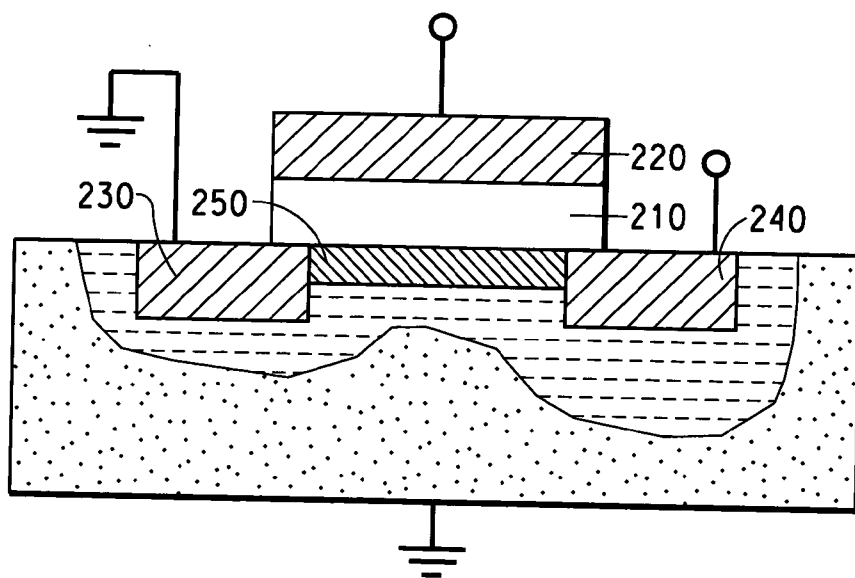

FIG. 2

ELECTRICALLY CONDUCTING ORGANIC POLYMER/NANOPARTICLE COMPOSITES AND METHODS FOR USE THEREOF

FIELD OF THE INVENTION

[0001] The invention relates to the use of conductive organic polymers in the production of pixellated electroluminescent devices, such as organic light emitting diodes, and thin film field effect transistor electrodes.

BACKGROUND

[0002] Conductive organic polymers originally attracted the attention of researchers over 20 years ago. The interest generated by these polymers compared to conventional conducting materials (e.g., metals, semiconductive metal oxides) was largely due to factors such as light weight, flexibility, durability, and potential ease of processing. To date the most commercially successful conductive organic polymers are the polyanilines and polythiophenes, which are marketed under a variety of tradenames. These materials can be prepared by polymerizing aniline or dioxythiophene monomers in aqueous solution in the presence of a water soluble polymeric acid, such as poly(styrenesulfonic acid) (PSS), as described in, for example, U.S. Pat. No. 5,300,575 entitled "Polythiophene dispersions, their production and their use." The recent development of electroluminescent (EL) devices for use in light emissive displays and thin film field effect transistors for use as electrodes has resulted in a new area of interest in conductive organic polymers. EL devices such as organic light emitting diodes (OLEDs) containing conductive organic polymers generally have the following configuration:

[0003] anode/buffer layer/EL polymer/cathode

[0004] The anode is typically any material that has the ability to inject holes into the otherwise filled π -band of the semiconducting, EL polymer, such as, for example, indium/tin oxide (ITO). The anode is optionally supported on a glass or plastic substrate. The EL polymer is typically a conjugated semiconducting organic polymer such as poly(paraphenylenevinylene) or polyfluorene. The cathode is typically any material, such as Ca or Ba, that has the ability to inject electrons into the otherwise empty π^* -band of the semiconducting, EL polymer.

[0005] The buffer layer is typically a conductive organic polymer which facilitates the injection of holes from the anode into the EL polymer layer. The buffer layer can also be called a hole-injection layer, a hole transport layer, or may be characterized as part of a bilayer anode. Typical aqueous-dispersible conductive organic polymers employed as buffer layers are the emeraldine salt form of polyaniline (PAni) or a polymeric dioxyalkylenethiophene doped with a polymeric sulfonic acid.

[0006] While the buffer layer must have some electrical conductivity in order to facilitate charge transfer, the highest conductivity of buffer layer films derived from commonly known aqueous polyaniline or polythiophene dispersion is generally in the range of about 10^{-3} S/cm. The conductivity is about three order magnitude higher than necessary. Indeed, in order to prevent cross-talk between anode lines (or pixels), the electrical conductivity of the buffer layers should be minimized to about 10^{-6} S/cm without negatively

affecting the light emitting properties of a device containing such a buffer layer. For example, a film made from a commercially available aqueous poly(ethylenedioxythiophene) dispersion, Baytron-P VP Al 4083 from H. C. Starck, GmbH, Leverkusen, Germany, has conductivity of $\sim 10^{-3}$ S/cm. This is too high to avoid cross-talk between pixels. Accordingly, there is a need for high resistance buffer layers for use in electroluminescent devices.

SUMMARY OF THE INVENTION

[0007] Compositions are provided comprising aqueous dispersions of electrically conducting organic polymers and a plurality of nanoparticles. Invention compositions are capable of providing continuous, smooth thin films as buffer layers in electroluminescent devices, such as organic light emitting diodes (OLEDs) or as electrodes for thin film field effect transistors. Nanoparticles contemplated for use in the practice of the invention can be inorganic or organic. Buffer layers containing inorganic or organic nanoparticles have a much lower conductivity than buffer layers without such nanoparticles. When incorporated into an electroluminescent (EL) device, buffer layers according to the invention provide high resistance while contributing to higher stress life of the EL device.

[0008] In accordance with another embodiment of the invention, there are provided electroluminescent devices comprising buffer layers cast from invention aqueous dispersions.

[0009] In accordance with a further embodiment of the invention, there are provided methods for reducing the conductivity of an electrically conductive organic polymer film cast from an aqueous dispersion of an electrically conducting polymer onto a substrate, comprising adding a plurality of nanoparticles to the aqueous dispersion.

[0010] In a still further embodiment of the invention, there are provided methods for producing buffer layers having increased thickness, the method comprising adding a plurality of nanoparticles to an aqueous dispersion of a conductive organic polymer, and casting a buffer layer from said aqueous dispersion onto a substrate.

[0011] In yet another embodiment of the invention, there are provided thin film field effect transistor electrodes cast from invention aqueous dispersions.

[0012] In a still further embodiment of the invention, there are provided methods for increasing conductivity of thin film field effect transistor electrodes cast from aqueous dispersion onto a substrate.

BRIEF DESCRIPTION OF THE DRAWINGS

[0013] FIG. 1 illustrates a cross-sectional view of an electronic device that includes a buffer layer according to the invention.

[0014] FIG. 2 illustrates a cross-sectional view of a thin film field effect transistor that includes an electrode according to the invention.

DETAILED DESCRIPTION

[0015] Compositions are provided comprising aqueous dispersions of electrically conducting organic polymers and a plurality of nanoparticles. As used herein, the term "dis-

persion" refers to a continuous medium containing a suspension of minute particles. In accordance with the invention, the "continuous medium" is typically an aqueous liquid, e.g., water. Nanoparticles according to the invention can be inorganic or organic. As used herein, the term "inorganic" means that the nanoparticles are substantially free of carbon. As used herein, the term "organic" means that the nanoparticles are composed substantially of carbon. As used herein, the term "nanoparticle" refers to particles having sizes less than 1000 nanometers (nm).

[0016] Compositions according to the invention typically contain a continuous aqueous phase in which the electrically conducting organic polymer is dispersed. Electrically conducting organic polymers contemplated for use in the practice of the invention include, for example, all forms of the polyanilines (e.g., leucoemeraldine, emeraldine, nigraniline, and the like) which are capable of forming acid/base salts to render the polymers electrically conductive. It is well known that different forms of polyaniline polymers can be synthesized, depending upon the degree of oxidation. Polyaniline (PAni) can generally be described as being composed of monomer units having aromatic amine nitrogen atoms, as in Formula I below, and/or aromatic imine nitrogen atoms, as in Formula II below:

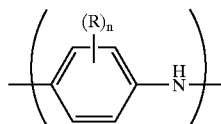

I

[0017] wherein:

[0018] n is an integer from 0 to 4;

[0019] and

[0020] R is independently selected so as to be the same or different at each occurrence and is selected from alkyl, alkenyl, alkoxy, cycloalkyl, cycloalkenyl, alkanoyl, alkythio, aryloxy, alkylthioalkyl, alkylaryl, arylalkyl, amino, alkylamino, dialkylamino, aryl, alkylsulfinyl, alkoxyalkyl, alkylsulfonyl, arylthio, arylsulfinyl, alkoxy carbonyl, arylsulfonyl, carboxylic acid, halogen, cyano, or alkyl substituted with one or more of sulfonic acid, carboxylic acid, halo, nitro, cyano or epoxy moieties; or any two R groups together may form an alkylene or alkenylene chain completing a 3, 4, 5, 6, or 7-membered aromatic or alicyclic ring, which ring may optionally include one or more divalent nitrogen, sulfur or oxygen atoms.

[0021] Although formulae I and II show the monomer units in the unprotonated form, it is known that in the presence of an acid (such as, poly(2-acrylamido-2-methyl-1-propanesulfonic acid (PAAMPSA), poly(styrenesulfonic acid) (PSS), and the like), the basic nitrogen atoms will be protonated to form a salt. The relative proportion of imine nitrogen atoms to amine nitrogen atoms increases with increasing oxidation. In one embodiment, the polyaniline is the emeraldine base form in which the ratio of monomer units having Formula I to those having Formula II is 2:1. In this embodiment, the ratio of amine nitrogen atoms to imine nitrogen atoms is 1:1.

[0022] In another embodiment, the electrically conductive organic polymer is poly(dioxythiophene). Poly(dioxythiophenes) contemplated for use in the practice of the invention have Formula III:

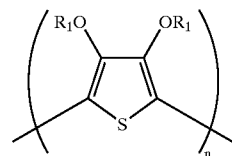

III

[0023] wherein:

[0024] R₁ and R₁' are each independently selected from hydrogen and alkyl having 1 to 4 carbon atoms,

[0025] or R₁ and R₁' taken together form an alkylene chain having 1 to 4 carbon atoms, which may optionally be substituted by alkyl or aromatic groups having 1 to 12 carbon atoms, or a 1,2-cyclohexylene radical, and

[0026] n is greater than about 9.

[0027] The electrically conductive organic polymers used in the invention compositions and methods are typically prepared by oxidatively polymerizing the corresponding monomers in aqueous solution containing a polymeric acid (e.g., PAAMPSA, PSS, and the like). The oxidative polymerization is carried out using an oxidizing agent such as ammonium persulfate, sodium persulfate, or the like. Thus, for example, when aniline is oxidatively polymerized in the presence of PAAMPSA, the electrically conductive acid/base salt PAni/PAAMPSA is formed. When ethylenedioxythiophene (EDT) is oxidatively polymerized in the presence of PSS, the electrically conductive acid/base salt poly(ethylenedioxythiophene) (PEDT)/PSS is formed.

[0028] The aqueous solution also can include a polymerization catalyst such as ferric sulfate, ferric chloride, and the like. The polymerization is typically carried out at low temperatures, e.g., between -10° C. and 30° C. After completion of the polymerization reaction, the polymers are optionally isolated from aqueous dispersion using a non-solvent for the polymers, e.g., acetone, and the like. When the electrically conductive organic polymer is isolated, the material is typically refined to produce polymer particles having a size less than about 1000 nm. In one embodiment, the polymer particles are less than about 500 nm. In another embodiment, the polymer particles are less than about 50 nm. The isolated electrically conductive organic polymer particles are then either directly combined with an aqueous dispersion of nanoparticles or the conductive organic polymer particles are redispersed in water prior to combination with an aqueous dispersion of nanoparticles.

[0029] In another embodiment of the invention methods, the oxidative polymerization is carried out in the presence of nanoparticles, thereby producing an aqueous dispersion without isolating the electrically conductive organic polymer. For example, nanoparticles may be added to an aqueous solution containing aniline monomers, thereby forming a dispersion. An oxidizing agent can then be added to poly-

merize the monomers in the presence of the nanoparticles. This embodiment of the invention is economically attractive since it provides invention aqueous dispersions in a “one-pot” synthesis. Invention aqueous dispersions prepared by either method provide the advantage of being easily filtered, for example, through a Millex 0.45 μm HV filter. Thus, invention aqueous dispersions readily provide continuous, smooth films.

[0030] Organic additives, such as steric stabilizers, may optionally be added to the aqueous solution prior to oxidative polymerization. These additives facilitate formation of electrically conductive organic polymers having nanometer sized particles. Organic additives include, for example, polyacrylamide, polyvinylalcohol, poly(2-vinylpyridine), poly(vinyl acetate), poly(vinyl methyl ether), poly(vinylpyrrolidone), poly(vinyl butyral), and the like.

[0031] Nanoparticles contemplated for use in the practice of the present invention can be either inorganic or organic. Inorganic nanoparticles contemplated for use in the practice of the invention include alumina, silica, metallic nanoparticles, electrically semiconductive metal oxides, and the like. In one embodiment, the electrically semiconductive metal oxide is selected from mixed valence metal oxides, such as zinc antimonates, and the like. In another embodiment, the metallic nanoparticles are molybdenum nanoparticles. Organic nanoparticles contemplated for use in the practice of the invention include colloidal sulfonic acids (such as perfluoroethylene sulfonates, and the like), polyacrylates, polyphosphonates, carbon nanotubes, and the like.

[0032] Nanoparticles contemplated for use in the practice of the invention may have a variety of shapes and sizes. In one embodiment, the nanoparticles are substantially spherical. In another embodiment, the nanoparticles are substantially elongated such as metal nanowires. Nanoparticles contemplated for use in the practice of the invention typically have an average particle diameter less than about 500 nm. In another embodiment, the nanoparticles have an average particle diameter less than about 100 nm. In still another embodiment, the nanoparticles have an average particle diameter less than about 50 nm. In another embodiment, the aspect ratio of elongated nano-particles is greater than 1 to 100. Aspect ratio is defined as ratio of particle width to particle length. For elongated particles, the “particle size” is considered to be the particle width. In another embodiment, the nano-particles have an irregular geometry. For irregularly-shaped particles, the “particle size” is considered to be size of the smallest screen opening through which the particle will pass. In another embodiment of the invention, there are provided buffer layers cast from aqueous dispersions comprising electrically conductive organic polymers and nanoparticles. Both the electrically conducting polymers and the nanoparticles can be readily dispersed in water. Thus, continuous, smooth films can be produced by casting from aqueous dispersions containing electrically conducting polymers and nanoparticles. Invention buffer layers have a reduced conductivity relative to buffer layers of identical composition except the inorganic nanoparticles are absent. Electrical resistivity is inversely proportional to electrical conductivity. Thus, as employed herein, the phrases “high resistance” and “low conductivity” are used interchangeably with reference to the buffer layers described herein. As used herein, the phrases “high resistance” and “low conductivity” each refer to a conductivity level less

than that of a commercially available buffer layers, i.e., less than about 1.0×10^{-3} S/cm. In another embodiment, the resistivity is preferably less than 1.0×10^{-5} S/cm. Resistivity and conductivity values are typically reported in units of ohm-centimeter (ohm-cm) and Siemens per centimeter (S/cm), respectively. As used herein, conductivity values are reported (using the unit S/cm) rather than resistivity values.

[0033] In another embodiment of the invention, there are provided electronic devices comprising at least one electroluminescent layer (usually a semiconductor conjugated polymer) positioned between two electrical contact layers, wherein at least one of the layers of the device includes a buffer layer of the invention. As shown in FIG. 1, a typical device has an anode layer 110, a buffer layer 120, an electroluminescent layer 130, and a cathode layer 150. Adjacent to the cathode layer 150 is an optional electron-injection/transport layer 140. Between the buffer layer 120 and the cathode layer 150 (or optional electron injection/transport layer 140) is the electroluminescent layer 130.

[0034] The device may include a support or substrate (not shown) that can be adjacent to the anode layer 110 or the cathode layer 150. Most frequently, the support is adjacent the anode layer 110. The support can be flexible or rigid, organic or inorganic. Generally, glass or flexible organic films are used as a support. The anode layer 110 is an electrode that is more efficient for injecting holes than the cathode layer 150. The anode can include materials containing a metal, mixed metal, alloy, metal oxide or mixed oxide. Suitable materials include the mixed oxides of the Group 2 elements (i.e., Be, Mg, Ca, Sr, Ba, Ra), the Group 11 elements, the elements in Groups 4, 5, and 6, and the Group 8-10 transition elements. If the anode layer 110 is to be light transmitting, mixed oxides of Groups 12, 13 and 14 elements, such as indium-tin-oxide, may be used. As used herein, the phrase “mixed oxide” refers to oxides having two or more different cations selected from the Group 2 elements or the Groups 12, 13, or 14 elements. Some non-limiting, specific examples of materials for anode layer 110 include indium-tin-oxide (“ITO”), aluminum-tin-oxide, gold, silver, copper, and nickel. The anode may also comprise an organic material such as polyaniline or polythiophene.

[0035] The anode layer 110 may be formed by a chemical or physical vapor deposition process or spin-cast process. Chemical vapor deposition may be performed as a plasma-enhanced chemical vapor deposition (“PECVD”) or metal organic chemical vapor deposition (“MOCVD”). Physical vapor deposition can include all forms of sputtering, including ion beam sputtering, as well as e-beam evaporation and resistance evaporation. Specific forms of physical vapor deposition include rf magnetron sputtering and inductively-coupled plasma physical vapor deposition (“IMP-PVD”). These deposition techniques are well known within the semiconductor fabrication arts.

[0036] Usually, the anode layer 110 is patterned during a lithographic operation. The pattern may vary as desired. The layers can be formed in a pattern by, for example, positioning a patterned mask or resist on the first flexible composite barrier structure prior to applying the first electrical contact layer material. Alternatively, the layers can be applied as an overall layer (also called blanket deposit) and subsequently patterned using, for example, a patterned resist layer and wet chemical or dry etching techniques. Other processes for

patterning that are well known in the art can also be used. When the electronic devices are located within an array, the anode layer **110** typically is formed into substantially parallel strips having lengths that extend in substantially the same direction.

[0037] The buffer layer **120** is usually cast onto substrates using a variety of techniques well-known to those skilled in the art. Typical casting techniques include, for example, solution casting, drop casting, curtain casting, spin-coating, screen printing, inkjet printing, and the like. Alternatively, the buffer layer can be patterned using a number of such processes, such as ink jet printing.

[0038] The electroluminescent (EL) layer **130** may typically be a conjugated polymer such as poly(paraphenylenevinylene) or polyfluorene. The particular material chosen may depend on the specific application, potentials used during operation, or other factors. The EL layer **130** containing the electroluminescent organic material can be applied from solution by any conventional technique, including spin-coating, casting, and printing. The EL organic materials can be applied directly by vapor deposition processes, depending upon the nature of the materials. In another embodiment, an EL polymer precursor can be applied and then converted to the polymer, typically by application of heat or other source of external energy (e.g., visible light or UV radiation).

[0039] Optional layer **140** can function both to facilitate electron injection/transport, and also serve as a confinement layer to prevent quenching reactions at layer interfaces. More specifically, layer **140** may promote electron mobility and reduce the likelihood of a quenching reaction if layers **130** and **150** would otherwise be in direct contact. Examples of materials for optional layer **140** include metal-chelated oxinoid compounds (e.g., Alq₃ or the like); phenanthroline-based compounds (e.g., 2,9-dimethyl-4,7-diphenyl-1,10-phenanthroline ("DDPA"), 4,7-diphenyl-1,10-phenanthroline ("DPA"), or the like); azole compounds (e.g., 2-(4-biphenyl)-5-(4-t-butylphenyl)-1,3,4-oxadiazole ("PBD" or the like), 3-(4-biphenyl)-4-phenyl-5-(4-t-butylphenyl)-1,2,4-triazole ("TAZ" or the like); other similar compounds; or any one or more combinations thereof. Alternatively, optional layer **140** may be inorganic and comprise BaO, LiF, Li₂O, or the like.

[0040] The cathode layer **150** is an electrode that is particularly efficient for injecting electrons or negative charge carriers. The cathode layer **150** can be any metal or nonmetal having a lower work function than the first electrical contact layer (in this case, the anode layer **110**). As used herein, the term "lower work function" is intended to mean a material having a work function no greater than about 4.4 eV. As used herein, "higher work function" is intended to mean a material having a work function of at least approximately 4.4 eV.

[0041] Materials for the cathode layer can be selected from alkali metals of Group 1 (e.g., Li, Na, K, Rb, Cs), the Group 2 metals (e.g., Mg, Ca, Ba, or the like), the Group 12 metals, the lanthanides (e.g., Ce, Sm, Eu, or the like), and the actinides (e.g., Th, U, or the like). Materials such as aluminum, indium, yttrium, and combinations thereof, may also be used. Specific non-limiting examples of materials for the cathode layer **150** include barium, lithium, cerium, cesium, europium, rubidium, yttrium, magnesium, and samarium.

[0042] The cathode layer **150** is usually formed by a chemical or physical vapor deposition process. In general, the cathode layer will be patterned, as discussed above in reference to the anode layer **110**. If the device lies within an array, the cathode layer **150** may be patterned into substantially parallel strips, where the lengths of the cathode layer strips extend in substantially the same direction and substantially perpendicular to the lengths of the anode layer strips. Electronic elements called pixels are formed at the cross points (where an anode layer strip intersects a cathode layer strip when the array is seen from a plan or top view).

[0043] In other embodiments, additional layer(s) may be present within organic electronic devices. For example, a layer (not shown) between the buffer layer **120** and the EL layer **130** may facilitate positive charge transport, band-gap matching of the layers, function as a protective layer, or the like. Similarly, additional layers (not shown) between the EL layer **130** and the cathode layer **150** may facilitate negative charge transport, band-gap matching between the layers, function as a protective layer, or the like. Layers that are known in the art can be used. In addition, any of the above-described layers can be made of two or more layers. Alternatively, some or all of inorganic anode layer **110**, the buffer layer **120**, the EL layer **130**, and cathode layer **150**, may be surface treated to increase charge carrier transport efficiency. The choice of materials for each of the component layers may be determined by balancing the goals of providing a device with high device efficiency with the cost of manufacturing, manufacturing complexities, or potentially other factors.

[0044] Depending upon the intended application of the electronic device, the EL layer **130** can be a light-emitting layer that is activated by signal (such as in a light-emitting diode) or a layer of material that responds to radiant energy and generates a signal, with or without an applied potential (such as detectors or voltaic cells). Examples of electronic devices that may respond to radiant energy are selected from photoconductive cells, photoresistors, photoswitches, phototransistors, and phototubes, and photovoltaic cells. After reading this specification, skilled artisans will be capable of selecting material(s) that are suitable for their particular applications. The light-emitting materials may be dispersed in a matrix of another material, with or without additives, but preferably form a layer alone. The EL layer **130** generally has a thickness in the range of approximately 50-500 nm.

[0045] In organic light emitting diodes (OLEDs), electrons and holes, injected from the cathode **150** and anode **110** layers, respectively, into the EL layer **130**, form negative and positively charged polarons in the polymer. These polarons migrate under the influence of the applied electric field, forming a polaron exciton with an oppositely charged species and subsequently undergoing radiative recombination. A sufficient potential difference between the anode and cathode, usually less than approximately 12 volts, and in many instances no greater than approximately 5 volts, may be applied to the device. The actual potential difference may depend on the use of the device in a larger electronic component. In many embodiments, the anode layer **110** is biased to a positive voltage and the cathode layer **150** is at substantially ground potential or zero volts during the operation of the electronic device. A battery or other power source(s) may be electrically connected to the electronic device as part of a circuit but is not illustrated in **FIG. 1**.

[0046] The invention also provides thin film field effect transistor electrodes. In thin film field effect transistors, a dielectric polymer or dielectric oxide thin film is provided with a gate electrode on one side and drain and source electrodes on the other side. Between the drain and source electrode, an organic semiconducting film is deposited. The organic semiconducting polymer film is typically cast from an organic solution using aromatic solvent such as toluene, or chlorinated organic solvent such as chloroform. To be useful for the electrode application, the conducting polymers and the liquids for dispersing or dissolving the conducting polymers must be compatible with the semiconducting polymers and the solvents for the semiconducting polymers to avoid re-dissolution of either conducting polymers or semiconducting polymers. Thin film field effect transistor electrodes fabricated from conducting polymers should have a conductivity greater than 10 S/cm. However, electrically conducting polymers made with a polymeric acid only provide conductivity in the range of $\sim 10^{-5}$ S/cm or lower. In order to enhance conductivity of the electrically conducting polymers without compromising processibility (such as casting, spin-coating, and the like) a highly conductive additive is needed. Accordingly, in another embodiment of the invention, there are provided thin film field effect transistor electrodes. Invention electrodes are cast from aqueous dispersions containing electrically conducting polymers and nanoparticles. In this embodiment, the nanoparticles are typically carbon nanotubes, metal nanoparticles, or metal nanowires resulting in electrodes having a conductivity of greater than about 10 S/cm. In a further embodiment, the electrically conducting polymers are polyanilines/polymeric acid, polydioxyalkylenethiophenes/polymeric acid, or the like.

[0047] The invention also provides thin film field effect transistors containing invention electrodes. Thin film field effect transistors, as shown in FIG. 2, are typically fabricated in the following manner. A dielectric polymer or dielectric oxide thin film 210 has a gate electrode 220 on one side and drain and source electrodes, 230 and 240, respectively, on the other side. Between the drain and source electrode, an organic semiconducting film 250 is deposited. Invention aqueous dispersions containing nanowires or carbon nanotubes are ideal for the applications of gate, drain and source electrodes because of their compatibility with organic based dielectric polymers and semiconducting polymers in solution thin film deposition.

[0048] In accordance with another embodiment of the invention, there are provided methods for reducing conductivity of an electrically conductive organic polymer film cast from aqueous dispersion onto a substrate to a value less than about 1×10^{-5} S/cm. Such a method can be performed, for example, by adding a plurality of nanoparticles to the aqueous dispersion of electrically conducting polymers. Surprisingly, it has been discovered that even electrically semi-conductive inorganic nanoparticles, when incorporated into an electrically conductive organic polymer film as described herein, reduce the conductivity of the polymer film. In one embodiment, the electrically conductive organic polymer film can be used as a buffer layer in electroluminescent devices. In another embodiment, the electrically conductive polymer film is PAni/PAAMPSA.

[0049] In a still further embodiment of the invention, there are provided methods for producing buffer layers having

increased thickness. Such a method can be performed, for example, by adding a plurality of nanoparticles to an aqueous dispersion of an electrically conductive organic polymer, and casting a buffer layer from said aqueous dispersion onto a substrate. Addition of nanoparticles to aqueous dispersions of conductive polymers produces aqueous dispersions having an increased viscosity. This enhanced viscosity provides increased control of the thickness of layers cast from the aqueous solutions. Control of buffer layer thickness is desirable since the appropriate thickness of a properly functioning buffer layer depends to some extent on the surface roughness of the metallic conductive layer onto which the buffer layer is deposited.

[0050] The invention will now be described in greater detail by reference to the following non-limiting examples.

EXAMPLES

Comparative Example 1

[0051] This comparative example illustrates preparation of PAni/PAAMPSA and its electrical conductivity and light emitting device properties as a buffer layer.

[0052] Synthesis of PAni/PAAMPSA was carried out in the following manner. Aniline (4.08 g) was dissolved in a 150 ml aqueous solution containing PAAMPSA (6.35 g, PAAMPSA was obtained from Sigma-Aldrich Corp., St. Louis, Mo., USA) in the form of 15 weight % aqueous solution; weight average molecular weight of the PAAMPSA is 2,000,000). The aqueous solution containing aniline and PAAMPSA was placed into a 4-necked 500 ml round bottomed flask and cooled to -4° C. with an ice/water bath. The solution was stirred continuously with a magnetic stirrer. To the chilled aqueous aniline/PAAMPSA solution, a 100 ml aqueous solution containing 4.235 g PAAMPSA and 2.36 g ammonium persulfate was added at a constant rate over a one hour period. The polymerization was allowed to proceed for 198 minutes.

[0053] The reaction mixture was then poured into two centrifuge bottles and centrifuged at 8000 rpm at 15° C. for 30 minutes. After centrifugation, the supernatant was slowly added to acetone to precipitate the polymeric product. After precipitation, the solid polymer was washed repeatedly in acetone, filtered, and dried overnight in a vacuum oven (~ 18 Hg., N_2 bleed, ambient temperature) Yield is 7.03 g.

[0054] PAni/PAAMPSA (1.21 g) as prepared above was dispersed in 39.12 g deionized water, which constitutes 3.0 wt % solid in the aqueous solution. The dispersion was tested for electrical conductivity and light emission properties. Commercially available indium tin oxide (ITO)/glass plates having ITO layers 100 to 150 nm thick were cut into samples 30 mm \times 30 mm in size. The ITO layers were subsequently etched with oxygen plasma. The ITO on the glass substrates to be used for electrical conductivity measurements were etched into a series of parallel lines of ITO to be used as electrodes. The ITO on the substrates to be made into LEDs for light emission measurement were etched into a 15 mm \times 20 mm layer of ITO to serve as the anode. The aqueous dispersion was then spin-coated onto each of the ITO/glass substrates at a spinning speed of 1,200 rpm. The resulting PAni/PAAMPSA layer was about 137 nm thick.

[0055] A sample for viscosity measurement was prepared as follows: 0.0989 g of the PAni/PAAMPSA was mixed with 9.9081 g deionized water, which constitutes 0.99 wt % PAni/PAAMPSA in the dispersion. The mixture was magnetically stirred overnight. It should be noted that the coating thickness is lower (137 nm vs. 300 nm) when compared with Invention Example 4 in spite of lower spin coating speed (1,200 rpm vs. 6,000 rpm). The comparison shows that the dispersion has a lower viscosity than the dispersion in Invention Example 4.

[0056] The PAni/PAAMPSA coated ITO/glass substrates were dried in nitrogen at 90° C. for 30 minutes before measuring for electrical conductivity. Electrical conductivity was determined by measuring the resistance between two electrodes and was calculated to be 3.6×10^{-5} S/cm based on the resistance, the thickness of the conductive layer and the distance between the two electrodes used to measure the resistance. The conductivity is shown in Table I.

[0057] For light emission measurements, when incorporated into a light emitting diode (LED), the PAni/PAAMPSA layer was top-coated with a super-yellow emitter poly(substituted-phenylene vinylene) (PDY 131 obtained from Covion Company, Frankfurt, Germany) to serve as the active electroluminescent (EL) layer. The thickness of the EL layer was approximately 70 nm. All film thicknesses were measured with a TENCOR 500 Surface Profiler. For the cathode, Ba and Al layers were vapor deposited onto the EL layer at a pressure of 1.3×10^{-4} Pa. The final thickness of the Ba layer was 3 nm; the thickness of the Al layer on top of the Ba layer was 300 nm. LED device performance was tested as follows. Measurements of current vs. applied voltage, light emission brightness vs. applied voltage, and light emission efficiency (candela/ampere-cd/A) were measured with a Keithley 236 source-measure unit from Keithley Instrument Inc. (Cleveland, Ohio), and a S370 Optometer with a calibrated silicon photodiode (UDT Sensor, Inc., Hawthorne, Calif.). Current was applied to each of five LED with a current density of 8.3 mA/cm² at room temperature. The average voltage to achieve the current density was 4.2 volts and the average light efficiency, and light emission brightness were 8.3 cd/A and 115 cd/m², respectively, as summarized in Table I. Table I also shows that device half-life at 80° C. and 3.3 mA/cm² current density was 12 hrs.

Invention Example 1

[0058] This example illustrates preparation of an aqueous PAni/PAAMPSA dispersion with silica nanoparticles and its electrical conductivity and light emission properties as a buffer layer.

[0059] PAni/PAAMPSA (0.63 g) prepared as in Comparative Example 1 was combined with 0.75 g Snowtex-UP® (0.75 g, Nissan Chemical Industries, Ltd. Tokyo, Japan), which contains 0.152 g silica nanoparticles, and 24.07 g deionized water. Snowtex-UP® is an aqueous dispersion having a pH from 9.0 to 10.5, and having a silica particle size of about 5-20 nm in width and about 40-300 nm in length. The silica:PAni/PAAMPSA weight ratio is 4.1:1.

[0060] The dispersion was tested for electrical conductivity and light emission properties in the same manner as described in Comparative Example 1. As shown in the results summarized in Table 1, a buffer layer cast from the

dispersion of Invention Example 1 has a lower conductivity (8.2×10^{-7} S/cm vs. 3.6×10^{-5} S/cm) and higher half-life (29 hours vs. 12 hours) when compared with Comparative Example 1. This example demonstrates effect of nanoparticles on reducing conductivity with enhanced device life-time.

Invention Example 2

[0061] This example illustrates preparation of an invention aqueous PAni/PAAMPSA dispersion with colloidal silica and its electrical conductivity and light emission properties as a buffer layer.

[0062] PAni/PAAMPSA (0.61 g) as prepared in Comparative Example 1 was combined with Snowtex-O® (0.75 g, from Nissan Chemical Industries, Ltd. Tokyo, Japan), which contains 0.153 g silica nanoparticles, and 23.47 g deionized water. Snowtex-O® is an aqueous dispersion having a pH range of 2-4 and having a silica particle size of 10-20 nm. The silica:PAni/PAAMPSA weight ratio is 3.99:1

[0063] The dispersion was tested for electrical conductivity and light emission properties in the same manner as described in Comparative Example 1. As shown in the results summarized in Table 1, a buffer layer cast from the dispersion of Invention Example 2 has a lower conductivity (7.6×10^{-7} S/cm vs. 3.6×10^{-5} S/cm) and higher half-life (30 hours vs. 12 hours) when compared with Comparative Example 1. This example again demonstrates effect of nano-particles on reducing conductivity with enhanced device life-time.

Invention Example 3

[0064] This example illustrates preparation of an invention aqueous PAni/PAAMPSA dispersion with electrically semi-conductive oxide and its electrical conductivity and light emission properties as a buffer layer.

[0065] PAni/PAAMPSA (0.90 g) as prepared in Comparative Example 1 was combined with Celnax CX-Z300H® (1.97 g, a zinc antimonite from Nissan Chemical Industries, Ltd. Tokyo, Japan), which contains 0.601 g conductive oxide particles, and 48.53 g deionized water. The Celnax CX-Z300H® is an aqueous dispersion having a pH of 6.85, and having 20 nm oxide nanoparticles. Conductivity of the oxide powder is 3.6 S/cm measured on a compressed dried pellet at a pressure of 160 Kg/cm². The oxides:PAni/PAAMPSA weight ratio is 1.50:1

[0066] The dispersion was tested for electrical conductivity and light emission properties in the same manner as described in Comparative Example 1. As shown in the results summarized in Table 1, a buffer layer cast from the dispersion of Invention Example 3 has a lower conductivity (8.3×10^{-8} S/cm vs. 3.6×10^{-5} S/cm) and higher half-life (61 hours vs. 12 hours) when compared with Comparative Example 1. This example again demonstrates effect of nano-particles on reducing conductivity with enhanced device life-time.

Invention Example 4

[0067] This example illustrates the preparation of an invention aqueous dispersion of PAni/PAAMPSA in the presence of SiO₂ nanoparticles and its electrical conductivity and light emitting properties as a buffer layer.

[0068] Synthesis of PAni/PAAMPSA in the presence of SiO₂ nanoparticles was carried out in the following manner. PAAMPSA (36.32 g of 15 wt % aqueous solution from Sigma-Aldrich Corp., St. Louis, Mo., USA) was placed in a 250 Nalgene® plastic bottle. To the PAAMPSA solution was added Snowtex-UP® (34.33 g from Nissan Chemical Industries, Ltd. Tokyo, Japan). Snowtex-UP® is an aqueous dispersion with pH of 9.0 to 10.5, containing silica particles sized 5-20 nm in width and 40-300 nm in length. The PAAMPSA/Snowtex-Up® silica mixture was dispersed in deionized water (150 ml). To this dispersion was added aniline (4.08 g). The aqueous PAAMPSA/Snowtex-Up®/aniline mixture was placed in a 4-necked 500 ml Round Bottomed Flask and then cooled to ~4° C. with an ice/water mixture. The solution was stirred continuously with a magnetic stirrer. To the chilled PAAMPSA/Snowtex-Up®/aniline dispersion 100 ml aqueous solution containing 4.493 g PAAMPSA (as above) and ammonium persulfate (2.33 g) was added over a one hour period. The reaction was allowed to proceed for 180 minutes.

Pa. The final thickness of the Ba layer was 3 nm; the thickness of the Al layer on top of the Ba layer was 300 nm. LED device performance was tested as follows. Measurements of current vs. applied voltage, light emission brightness vs. applied voltage, and light emission efficiency (candela/ampere-cd/A) were measured with a Keithley 236 source-measure unit from Keithley Instrument Inc. (Cleveland, Ohio), and a S370 Optometer with a calibrated silicon photodiode (UDT Sensor, Inc., Hawthorne, Calif.). Current was applied to each of five LED devices with a current density of 8.3 mA/cm² at room temperature. The average voltage to achieve the current density was 4.3 volts and the average light efficiency, and light emission brightness were 5.3 cd/A and 130 cd/m², respectively, as summarized in Table I. Table I also shows that device half-life at 80° C. and 3.3 mA/cm² current density was 42 hrs. It should be noted that the half-life is enhanced 4× and emission intensity is higher (130 cd/m² vs. 115) when compared with the PAni/PAAMPSA without silica in spite of the thickness being 2.2 times the thickness illustrated in Comparative Example 1.

TABLE 1

Effect of inorganic nanoparticles added to PAni/PAAMPSA on light emission properties of OLEDs on a glass substrate						
Example	Coating thickness (nm)	Conductivity (S/cm)	Voltage (volt) @ 8.3 mA/cm ²	Efficiency (Cd/A) @ 8.3 mA/cm ²	Brightness (Cd/m ²) @ 3.3 mA/cm ² , 80° C.	Half-life (hr) @ 3.3 mA/cm ² , 80° C.
Comparative Example 1	137 @ 1,200 rpm	3.6 × 10 ⁻⁵	4.2	8.3	115	12
Invention Example 1	114 @ 1,200 rpm	8.2 × 10 ⁻⁷	4.8	8.1	135	29
Invention Example 2	166 @ 1,200 rpm	7.6 × 10 ⁻⁷	4.9	7.4	108	30
Invention Example 3	113 @ 1,200 rpm	8.3 × 10 ⁻⁸	4.1	8.0	148	61
Invention Example 4	300 @ 6,000 rpm	9.0 × 10 ⁻⁷	4.3	5.3	130	42

[0069] The reaction mixture was then poured into two centrifuge bottles and centrifuged at 8000 rpm at 15° C. for 30 minutes. After centrifugation, the supernatant was slowly added to acetone to precipitate the polymeric product. After precipitation, the solid polymer was washed repeatedly in acetone, filtered, and dried overnight in a vacuum oven (~18 Hg., N₂ bleed, ambient temperature) (Yield was 14.19 g). It should be noted that the yield is almost twice the yield in Comparative Example 1. The increase in yield indicates that SiO₂ nanoparticles are present within the PAni/PAAMPSA.

[0070] PAni/PAAMPSA/SiO₂ (1.20 g, as prepared above) was dispersed in 38.80 g deionized water, which dispersion constitutes 3.0 wt % solid in the water. A buffer layer was cast onto an ITO substrate as in the previous examples. For light emission measurements, the PAni/PAAMPSA/silica layer was then top-coated with a super-yellow emitter poly(substituted-phenylene vinylene) (PDY 131 obtained from Covion Company, Frankfurt, Germany) to serve as the active electroluminescent (EL) layer in an LED device. The thickness of the EL layer was approximately 70 nm. Thickness of all films was measured with a TENCOR 500 Surface Profiler. For the cathode, Ba and Al layers were vapor deposited on top of the EL layer under a vacuum of 1.3×10⁻⁴

[0071] As shown in Table 2, the aqueous dispersion of Invention Example 4 produces a 300 nm coating thickness at a spinning speed of 6,000 rpm. The coating thickness is much higher than that of Comparative Example 1 (300 nm vs. 137 nm) despite a higher spin-coating speed (6,000 rpm vs. 1,200 rpm). The comparison shows that the PAni/PAAMPSA polymerized with silica nanoparticles has a higher viscosity than PAni/PAAMPSA polymerized without silica nanoparticles. As shown in Table II, this increased viscosity produces buffer layers having an increased thickness. The dispersion for viscosity measurement was prepared as follows: 0.0999 g of the PAni/PAAMPSA/silica was mixed with 9.9164 g deionized water, which constitutes 1.00 wt % PAni/PAAMPSA/silica in the dispersion.

TABLE 2

Viscosity of Aqueous PAni/PAAMPSA Dispersions			
Sample	Viscosity (cps)		
	10 s ⁻¹	100 s ⁻¹	1000 s ⁻¹
Comparative Example 1	5.50	4.52	4.10

TABLE 2-continued

Viscosity of Aqueous PAni/PAAMPSA Dispersions			
Sample	Viscosity (cps)		
	10 s ⁻¹	100 s ⁻¹	1000 s ⁻¹
Invention Example 4	8.30	6.80	6.15

Invention Example 5

[0072] This example demonstrates the integrity of solid films, prepared from a commercial aqueous PEDT dispersion, in organic solvents

[0073] In this example, a commercially available aqueous PEDT dispersion (Baytron-P VP Al 4083 from H. C. Starck, GmbH, Leverkusen, Germany), which has conductivity of $\sim 10^{-3}$ S/cm, was dried to solid films in a glass beaker under a nitrogen flow at room temperature. The dried films were mixed with common organic solvents (such as toluene, chloroform, dichloromethane, or the like) used to dissolve organic semiconducting polymers in the manufacture of thin film field effect transistors. The film flakes were not swollen by either of the organic liquids nor discolored the liquid. This result clearly demonstrates that PEDT films made from the Baytron-P are compatible with the organic solvents for semiconducting polymers, thereby demonstrating utility as electrodes for thin film field effect transistors.

Invention Example 6

[0074] This example demonstrates the integrity of solid films, prepared from an aqueous dispersion of PAni/PAAMPSA in organic solvents.

[0075] In this example, the aqueous dispersion of PAni/PAAMPSA prepared in Comparative Example 1 was dried to solid films in a glass beaker under a nitrogen flow at room temperature. The dried films were mixed with common organic solvents (such as toluene, chloroform, dichloromethane, or the like) used to dissolve organic semiconducting polymers in the manufacture of thin film field effect transistors. The film flakes were not swollen by either of the organic liquids nor discolored the liquid. This result clearly demonstrated that the PAni/PAAMPSA films made from aqueous dispersions of PAni/PAAMPSA are compatible with the organic solvents for semiconducting polymers, thereby demonstrating utility as electrodes for thin film field effect transistors.

Invention Example 7

[0076] This example illustrates the preparation of an invention aqueous dispersion containing a polyaniline/polymeric acid or a poly(dioxyethylenethiophene)/polymeric acid and highly conductive nanoparticles.

[0077] As shown in Comparative Example 1, electrical conductivity of PAni/PAAMPSA cast from an aqueous dispersion of PAni/PAAMPSA is only 3.6×10^{-5} S/cm, which is not sufficient for the application as gate, drain or source electrodes of thin film field effect transistors. The highest conductivity ever achieved from aqueous dispersion of PAni, for example from Ormecon (Amersbeck, Germany)

or PEDT, for example Baytron-P, is about 10^{-3} S/cm, which is still too low for the application. However, use of invention aqueous conducting polymer dispersions containing nanoparticles such as nano-wire or nano-particles of metal or carbon nanotubes dramatically increases the conductivity of electrodes cast from these aqueous dispersions. For example, metallic molybdenum wires having diameter of 15 nm and conductivity of 1.7×10^4 S/cm can be used for enhanced conductivity. Carbon nanotubes having dimension of 8 nm diameter and 20 μ m length and conductivity of 60 S/cm can also be used to enhance conductivity. Because of the high conductivity of the nanoparticles and dispersibility of the particles in water, composite aqueous dispersions consisting of the electrically conducting polymers and the highly conductive nanoparticles can be readily prepared for fabricating continuous, smooth films as drain, source or gate electrodes in thin film field effect transistors.

[0078] While the invention has been described in detail with reference to certain preferred embodiments thereof, it will be understood that modifications and variations are within the spirit and scope of that which is described and claimed.

What is claimed is:

1. A composition comprising an aqueous dispersion of an electrically conductive organic polymer and a plurality of nanoparticles.
2. A composition according to claim 1, wherein said electrically conductive organic polymer is selected from polyaniline with poly(2-acrylamido-2-methyl-1-propane-sulfonic acid) as the counterion (PAni/PAAMPSA) and poly(ethylenedioxythiophene) with poly(styrenesulfonic acid) as the counter ion (PEDT/PSS).
3. A composition according to claim 1, wherein said nanoparticles are inorganic nanoparticles.
4. A composition according to claim 3, wherein said inorganic nanoparticles are selected from silica, alumina, and electrically conductive metal oxides.
5. A composition according to claim 1, wherein said nanoparticles are organic nanoparticles.
6. A composition according to claim 5, wherein said organic nanoparticles are selected from polyacrylates, carbon nanotubes, and perfluoroethylene sulfonates.
7. A composition according to claim 1, wherein said nanoparticles have a particle size less than about 500 nm.
8. A composition according to claim 1, wherein said nanoparticles have a particle size less than about 250 nm.
9. A composition according to claim 1, wherein said nanoparticles have a particle size less than about 50 nm.
10. A composition according to claim 4, wherein the weight ratio of silica:electrically conductive polymer is about 4:1.
11. A composition according to claim 4, wherein the weight ratio of electrically conductive oxides:electrically conductive polymer is about 1.5:1.
12. A high resistance buffer layer comprising an electrically conductive polymer and a plurality of nanoparticles dispersed therein.
13. A high resistance buffer layer according to claim 12, wherein said electrically conductive polymer is selected from PAni/PAAMPSA and PEDT/PSS.
14. A high resistance buffer layer according to claim 12, wherein said nanoparticles are inorganic nanoparticles.

15. A high resistance buffer layer according to claim 12, wherein said inorganic nanoparticles are selected from silica, alumina, or electrically conductive metal oxides.

16. A high resistance buffer layer according to claim 12, wherein said nanoparticles are organic nanoparticles.

17. A high resistance buffer layer according to claim 12, wherein said organic nanoparticles are selected from polyacrylates, carbon nanotubes, and perfluoroethylene sulfonates

18. A high resistance buffer layer according to claim 12, wherein said layer has a conductivity of less than about 1×10^{-3} S/cm.

19. A high resistance buffer layer according to claim 12, wherein said layer has a conductivity of less than about 1×10^{-3} S/cm.

20. An organic light emitting diode (OLED) comprising a high resistance buffer layer comprising an electrically conductive polymer and a plurality of nanoparticles dispersed therein.

21. An OLED according to claim 20, wherein said electrically conductive polymer is selected from PANi/PAAMPSA or PEDT/PSS.

22. An OLED according to claim 20, wherein said nanoparticles are inorganic nanoparticles.

23. An OLED according to claim 20, wherein said inorganic nanoparticles are selected from silica, alumina, or electrically conductive metal oxides.

24. An OLED according to claim 20, wherein said nanoparticles are organic nanoparticles.

25. An OLED according to claim 20, wherein said organic nanoparticles are selected from polyacrylates, carbon nanotubes, and perfluoroethylene sulfonates.

26. An OLED according to claim 20, wherein said buffer layer has a conductivity less than about 1×10^{-3} S/cm.

27. A thin film field effect transistor electrode, comprising an electrically conductive polymer and a plurality of nanoparticles dispersed therein.

28. A thin film field effect transistor electrode according to claim 36, wherein said electrically conductive polymer is selected from PANi/PAAMPSA or PEDT/PSS.

29. A thin film field effect transistor electrode according to claim 27, wherein said nanoparticles are inorganic nanoparticles.

30. A thin film field effect transistor electrode according to claim 27, wherein said inorganic particles are metallic nanoparticles.

31. A thin film field effect transistor electrode according to claim 27, wherein said metallic nanoparticles are molybdenum nanoparticles.

32. A thin film field effect transistor electrode according to claim 27, wherein said nanoparticles are organic nanoparticles.

33. A thin film field effect transistor electrode according to claim 27, wherein said organic nanoparticles are carbon nanotubes.

34. A thin film field effect transistor comprising an electrode according to claim 27.

35. A thin film field effect transistor according to claim 34, wherein said thin film field effect transistor has a conductivity greater than about 10 S/cm.

36. A method for reducing conductivity of an electrically conductive organic polymer film cast from aqueous dispersion onto a substrate to a value less than about 1×10^{-3} S/cm, comprising adding a plurality of nanoparticles to said aqueous solution.

37. A method for producing buffer layers having increased thickness, comprising adding a plurality of nanoparticles to an aqueous dispersion of a conductive organic polymer, and casting a buffer layer from said aqueous dispersion onto a substrate.

38. A method for increasing conductivity of thin film field effect transistor electrodes cast from aqueous dispersion onto a substrate to a value greater than about 10^{-3} S/cm, comprising adding a plurality of nanoparticles to said aqueous solution.

39. A method according to claim 38, wherein said nanoparticles are selected from metal nanoparticles and carbon nanotubes.

* * * * *