



(72) JACKSON, LABAN P., US

(72) COLE, BRUCE, US

(72) MARTIN, H. LEE, US

(71) INTERACTIVE PICTURES CORPORATION, US

(51) Int.Cl.<sup>6</sup> H04N 7/00

(30) 1997/10/08 (60/061,342) US

(54) **PROCEDE ET SYSTEME DE PRODUCTION ET DE  
VISUALISATION D'IMAGES STEREOSCOPIQUES  
TOTALEMENT IMMERSIVES**

(54) **METHOD AND SYSTEM FOR THE CREATION AND  
INTERACTIVE VIEWING OF TOTALLY IMMERSIVE  
STEREOSCOPIC IMAGES**

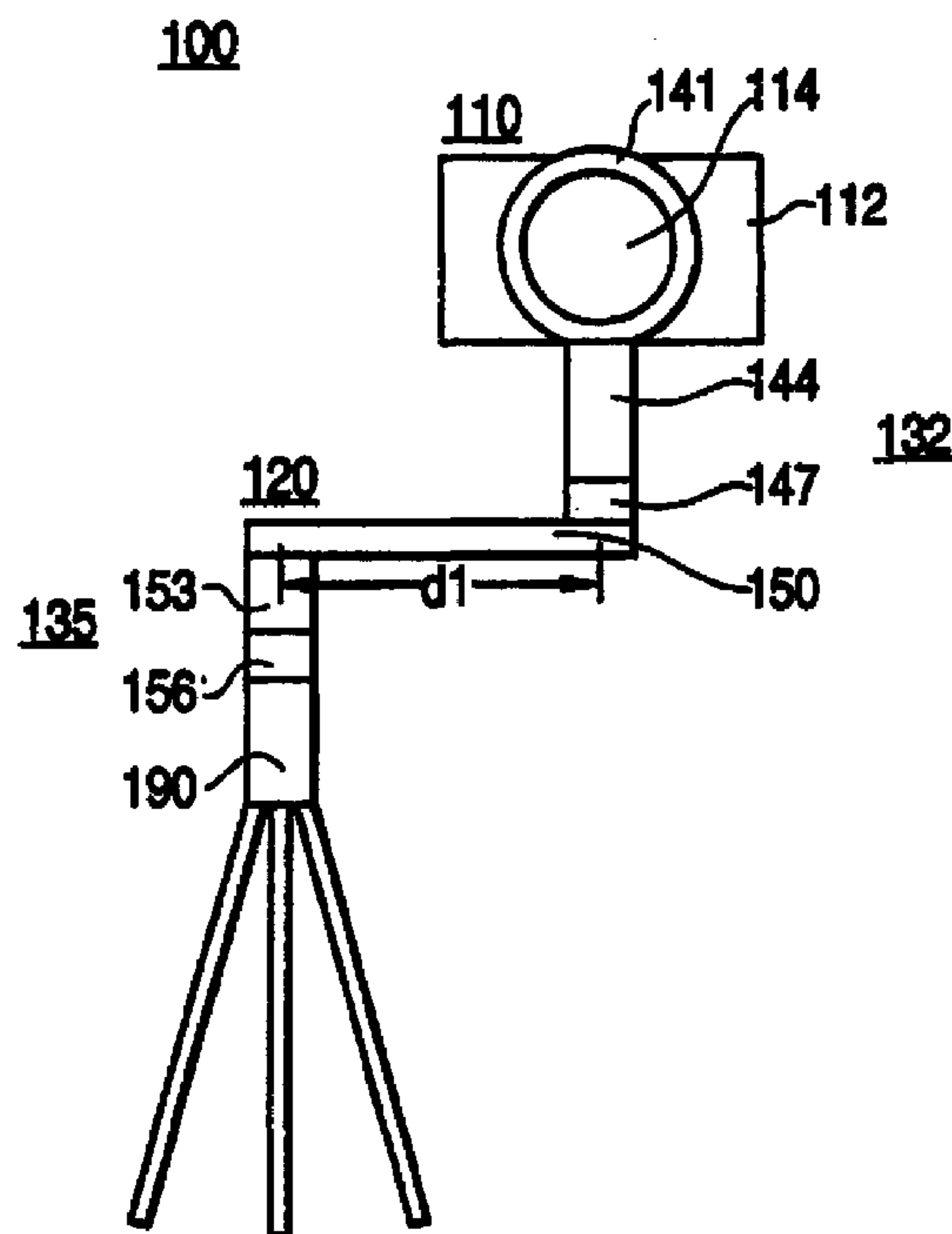

(57) L'invention concerne un procédé et un système de production et de visualisation d'images stéréoscopiques immersives. La production de deux images immersives à partir d'une plate-forme (120) de caméra décalée permet d'obtenir une illusion de profondeur par la présentation d'une vue gauche et droite sous forme d'image panoramique interactive. En capturant deux images immersives sur un appareil (110) comportant une séparation horizontale des centres de chaque image

(57) A method and system for the creation and viewing of stereoscopic immersive images. By creating two immersive images from an offset camera platform (120), the illusion of depth can be provided by left and right views in the form of an interactive panoramic image. By capturing two immersive images on a fixture (110) with horizontal separation of the centers of each immersive image, each constructed from a sequence of fisheye images that are captured in a constant direction and



(21) (A1) **2,305,229**  
(86) 1998/10/08  
(87) 1999/04/15

immersive, chacune de celles-ci étant construite à partir d'une séquence d'images de grand angulaire extrême qui sont capturées dans une direction constante, puis réunies, on produit deux fichiers (294, 298) qui peuvent être utilisés pour obtenir un affichage stéréoscopique. Les fichiers obtenus peuvent être affichés au moyen d'écrans (440) stéréoscopiques comprenant des moniteurs doubles, un pour chaque oeil, ou des écrans à obturateur pour chaque oeil à partir d'un moniteur simple, ou des écrans à filtres polarisés qui dirigent des vues séparées vers chaque oeil.

seamed together, two files (294, 298) that can be used to produce a stereoscopic display are created. The resulting files can be displayed using any number of stereoscopic displays (440) including dual monitors, one for each eye, or shuttered displays for each eye from a single monitor, or displays with polarized filters directing separate views to each eye.



PCT

WORLD INTELLECTUAL PROPERTY ORGANIZATION  
International Bureau

## INTERNATIONAL APPLICATION PUBLISHED UNDER THE PATENT COOPERATION TREATY (PCT)

<p>(51) International Patent Classification <sup>6</sup> : <b>H04N 7/00</b></p>	<p><b>A1</b></p>	<p>(11) International Publication Number: <b>WO 99/18725</b></p> <p>(43) International Publication Date: 15 April 1999 (15.04.99)</p>
<p>(21) International Application Number: PCT/US98/21304</p> <p>(22) International Filing Date: 8 October 1998 (08.10.98)</p> <p>(30) Priority Data: 60/061,342 8 October 1997 (08.10.97) US</p> <p>(63) Related by Continuation (CON) or Continuation-in-Part (CIP) to Earlier Application US 60/061,342 (CIP) Filed on 8 October 1997 (08.10.97)</p> <p>(71) Applicant (for all designated States except US): INTERACTIVE PICTURES CORPORATION (IPIX) [US/US]; Suite 100, 1009 Commerce Park Drive, Oak Ridge, TN 98052 (US).</p> <p>(72) Inventors; and (75) Inventors/Applicants (for US only): JACKSON, Laban, P. [US/US]; 2706 Fairmont Boulevard, Knoxville, TN 37917 (US). COLE, Bruce [US/US]; 620 West Vanderbilt Drive, North Oak Ridge, TN 37830 (US). MARTIN, H., Lee [US/US]; 11615 South Monticello Drive, Knoxville, TN 37922 (US).</p>	<p>(74) Agents: JACKSON, Thomas, H. et al.; Banner &amp; Witcoff, Ltd., 11th floor, 1001 G Street, N.W., Washington, DC 20001-4597 (US).</p> <p>(81) Designated States: AL, AM, AT, AU, AZ, BA, BB, BG, BR, BY, CA, CH, CN, CU, CZ, DE, DK, EE, ES, FI, GB, GE, GH, GM, HR, HU, ID, IL, IS, JP, KE, KG, KP, KR, KZ, LC, LK, LR, LS, LT, LU, LV, MD, MG, MK, MN, MW, MX, NO, NZ, PL, PT, RO, RU, SD, SE, SG, SI, SK, SL, TJ, TM, TR, TT, UA, UG, US, UZ, VN, YU, ZW, ARIPO patent (GH, GM, KE, LS, MW, SD, SZ, UG, ZW), Eurasian patent (AM, AZ, BY, KG, KZ, MD, RU, TJ, TM), European patent (AT, BE, CH, CY, DE, DK, ES, FI, FR, GB, GR, IE, IT, LU, MC, NL, PT, SE), OAPI patent (BF, BJ, CF, CG, CI, CM, GA, GN, GW, ML, MR, NE, SN, TD, TG).</p> <p><b>Published</b> With international search report. With amended claims.</p>	

(54) Title: METHOD AND SYSTEM FOR THE CREATION AND INTERACTIVE VIEWING OF TOTALLY IMMERSIVE STEREO-SCOPIC IMAGES

## (57) Abstract

A method and system for the creation and viewing of stereoscopic immersive images. By creating two immersive images from an offset camera platform (120), the illusion of depth can be provided by left and right view in the form of an interactive panoramic image. By capturing two immersive images on a fixture (110) with horizontal separation of the centers of each immersive image, each constructed from a sequence of fisheye images that are captured in a constant direction and seamed together, two files (294, 298) that can be used to produce a stereoscopic display are created. The resulting files can be displayed using any number of stereoscopic displays (440) including dual monitors, one for each eye, or shuttered displays for each eye from a single monitor, or displays with polarized filters directing separate views to each eye.

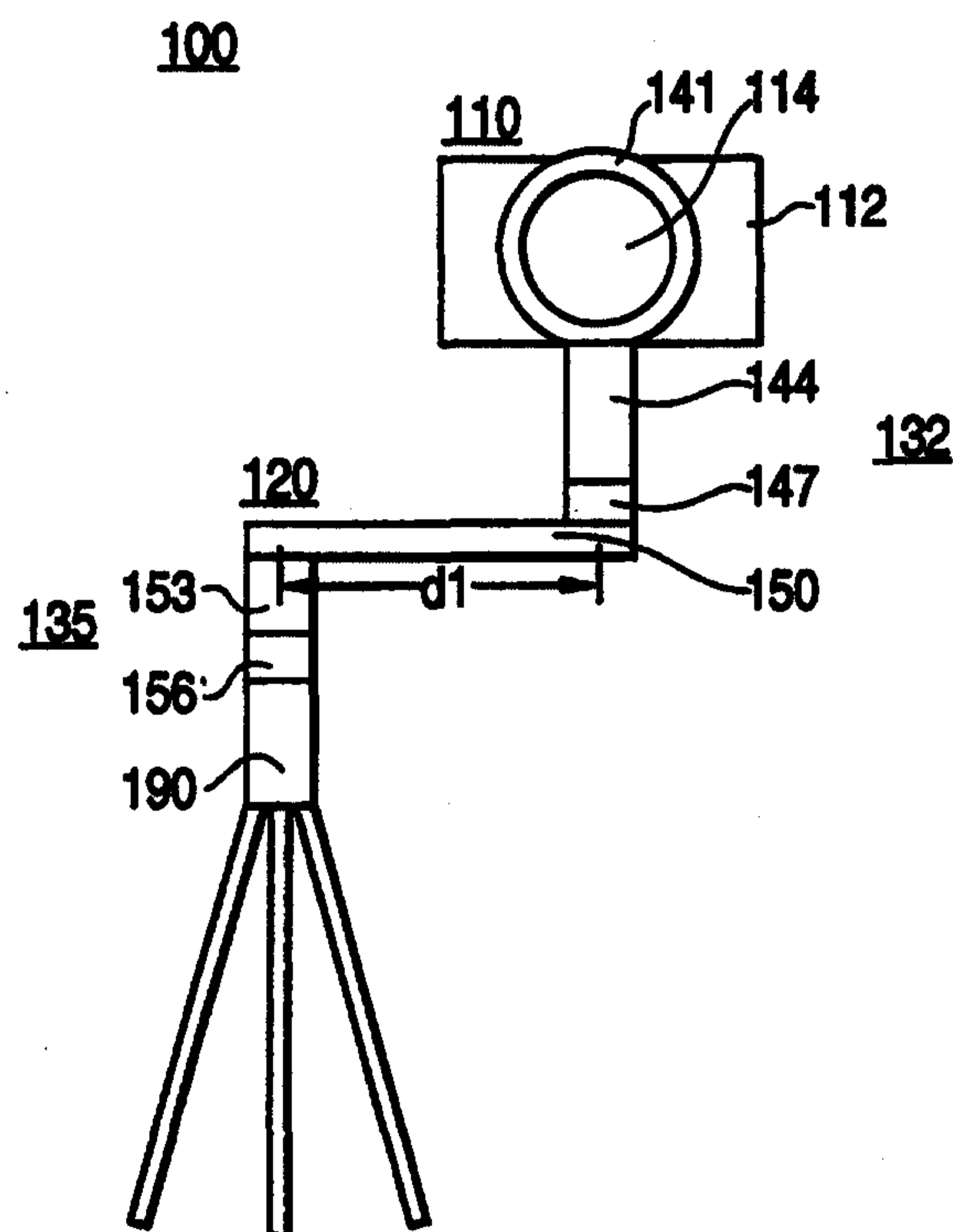

## **Method And System For The Creation and Interactive Viewing of Totally Immersive Stereoscopic Images**

This application makes reference to, incorporates herein and claims all benefits  
5 accruing under 35 U.S.C. § 119(e) by virtue of a provisional patent application earlier  
filed in the United States Patent and Trademark Office on October 8, 1997, entitled  
METHOD AND SYSTEM FOR CREATION AND INTERACTIVE VIEWING OF  
TOTALLY IMMERSIVE STEREOSCOPIIC IMAGES which was duly assigned Serial  
No. 60/061,342. This application is a continuation-in-part of U.S. Patent Application  
10 Serial No. 08/767,376 filed December 16, 1996, which is a continuation-in-part of U.S.  
Patent Application Serial No. 08/516,629 filed August 18, 1995, which is a continuation-  
in-part of U.S. Patent Application Serial No. 08/494,599 filed June 23, 1995 (now  
abandoned), which is a continuation-in-part of U.S. Patent Application Serial No.  
08/386,912 filed February 8, 1995, which is a continuation of U.S. Patent Application  
15 Serial No. 08/339,663 filed November 11, 1994, which is a continuation of U.S. Patent  
Application Serial No. 08/189,585 filed January 31, 1994 (now U.S. Patent No.  
5,384,588), which is a continuation-in-part of U.S. Patent Application Serial No.  
08/014,508 filed February 8, 1993 (now U.S. Patent No. 5,359,363), which is a  
continuation-in-part of U.S. Patent Application Serial No. 07/699,366 filed May 13,  
20 1991(now U.S. Patent No. 5,185,667). Furthermore, U.S. Patent Application No.  
08/494,599 filed June 23, 1995 (now abandoned), and U.S. Patent Application Serial No.  
08/516,629 filed August 18, 1995, are both continuation-in-parts of U.S. Patent  
Application Serial No. 08/373,446 filed January 17, 1995, which is a continuation-in-part  
of U.S. Patent Application Serial No. 08/189,585 filed January 31, 1994 (now U.S. Patent  
25 No. 5,384,588). This application is also a continuation-in-part of U.S. Patent Application  
Serial No. 08/863,584 filed May 27, 1997, which is a continuation-in-part of U.S.  
application serial number 08/386,912 filed February 8, 1995, which is a continuation of  
U.S. Patent Application Serial No. 08/339,663 filed November 11, 1994, which is a  
continuation of U.S. Patent Application Serial No. 08/189,585 filed January 31, 1994

(now U.S. Patent No. 5,384,588), which is a continuation-in-part of U.S. Patent Application Serial No. 08/014,508 filed February 8, 1993 (now U.S. Patent No. 5,359,363), which is a continuation-in-part of U.S. Patent Application Serial No. 07/699,366 filed May 13, 1991 (now U.S. Patent No. 5,185,667). In addition, U.S. Patent Application Serial No. 08/863,584 filed May 27, 1997, is also a continuation-in-part of U.S. application serial number 08/373,446 filed January 17, 1995, which is a continuation-in-part of U.S. Patent Application Serial No. 08/189,585 filed January 31, 1994 (now U.S. Patent No. 5,384,588).

### **Technical Field**

10 This invention relates to support structures for image capturing devices and the methods for their use in the capture and creation of totally immersive stereoscopic images from fisheye or wide-angle images captured from the support structures.

### **Background of the Invention**

15 One of the purposes of modern photography is to encourage a viewer to explore an image and, in the process, transform the image into something more than a two dimensional representation of space. Panoramic images provide some feeling of being enveloped into an image, but this feeling diminishes at the periphery of the image.

20 To create a greater feeling of being enveloped and to provide a greater resolution image to a viewer, high numbers of picture elements have been combined to create even larger panoramic images. See, for example, U.S. Patent No. 5,083,389 to Alperin which is expressly incorporated herein by reference. Unfortunately, the combining of a plurality of images creates the potential for distortions at the seams of the images. Additionally, the number of images required to create a composite image in this manner is burdensome.

25 A partially enveloping image was disclosed in U.S. Patent No. 5,185,667 to Zimmermann, expressly incorporated by reference to its entire contents. Zimmermann discloses a system and method for navigating about a spherically distorted image where the user's inputs control the displayed portion of the screen.

30 Another difficulty of capturing large field-of-view images is the potential for misalignment of a camera as it is moved from a first image capturing position to a second image capturing position. Further, with multiple images being captured, the possible

alignment error grows with each movement of a misaligned camera. The resulting images then require additional manual correlation to compensate for any misalignment of the camera.

5 Yet another difficulty is providing a supporting structure which allows for the quick and easy capture of an image. Another difficulty is providing a portable support for a camera where the support does not require numerous adjustments to capture panoramic or spherical images. See, for example, U.S. Patent Application Serial No. 08/767,376 filed December 16, 1996 to Kuban et al. that is expressly incorporated herein by reference. While the Kuban et al. system solves the above problems, it is directed to the capture of  
10 images about a single axis of rotation, which effects the usefulness of these images when used for stereoscopic viewing. This effect is due to the identical image being used as the display in each eye, which does not account for the normal inter-pupillary distance between a user's eyes. This inter-pupillary distance is necessary for realistic stereoscopic viewing.

15 None of this previous work uses the new techniques described in this application for the capture and creation of stereoscopic immersive images. Therefore, there is a need for the method of and apparatus for capturing fisheye or wide-angle images and then creating and displaying totally immersive stereoscopic images from the fisheye and wide-angle images.

### 20 Summary of the Invention

The problems and related problems of the prior art are overcome by the principles of the present invention. According to these principles, a lens supporting structure is disclosed which provides exact alignment of and offsets for a image capture means. The exact alignment produces captured images that are properly aligned for easily seaming  
25 together the captured images to form spherical images. In addition, the combination of the exact alignment and offsets is used to produce multiple, properly aligned captured images to form a seamed panoramic view. Embodiments of the present invention include a base support structure that rotably attaches to an offset mounting system that includes a rotatable eccentric mount support and a rotatable lens mount support that attaches to and  
30 supports a image capture means. Embodiments of the present invention also contemplate

the offset mounting system and rotatable lens mount taking on a variety of forms and combinations. For simplicity, the rotatable lens mount is described herein as a ring and associated elements thereof. Additional configurations of the rotatable lens mount include a supporting platform and equivalents thereof. In at least one embodiment, the rotatable lens mount attaches to a rotating sleeve that rotates about a central bore. In one embodiment the supporting structure is a tripod; in another a monopod is used to diminish the footprint of the structure on the image.

In one embodiment, the axis of rotation of the lens mount coincides with a plane of an objective lens of the lens where the plane signifies a large field-of-view of the lens. In another embodiment, the plane signifies an approximate 180-degree field-of-view of the lens. In yet another embodiment, the plane signifies a field-of-view greater than 180 degrees. The axis of rotation of the lens mount is preferably co-linear with the axis of rotation of the lens. By rotating the image capture means about the rotatable eccentric mount support and by rotating the lens about the axis of rotation of the lens mount, multiple images are captured. In particular, through the controlled positions of the eccentric and lens mounts, the captured images are seamed together to form totally immersive stereoscopic images. The number of fixed positions of the lens mount accounts for lenses with various fields-of-view.

In one embodiment, the offset mounting system consists of a lens mount, where the lens mount bottom securely attaches to the top end of the top-half of a two-stop rotator. The bottom end of the top-half of the two-stop rotator is rotably connected to the top end of the bottom-half of the two-stop rotator and the bottom end of the bottom-half of two-stop rotator securely attaches to the top side at a first end of the eccentric mount. The bottom side at a second end of the eccentric mount securely attaches to the top end of the top-half of an n-stop rotator, where n is a number greater than one. The bottom end of the top-half of the n-stop rotator is rotably connected to the top end of the bottom-half of the n-stop rotator.

By way of example only, capturing and seaming together left and right hemispherical images are described in greater detail in co-pending U.S. Application Serial No. 08/863,584 filed May 27, 1997, which is incorporated by reference herein as to its

entire contents.

Additional techniques for capturing first and second images having approximately equal to or greater than 180 degree field-of-view are described in co-pending U.S. Application Serial No. 08/494,599 filed June 23, 1995, which is incorporated by reference  
5 herein as to its entire contents.

Through the use of perspective correction and manipulation disclosed in U.S. Patent No. 5,185,667 to Zimmermann and its progeny including U.S. Patent Nos. 5,384,588; 5,359,363; and 5,313,306 and U.S. Patent Application Serial Nos. 08/189,585  
10 filed January 31, 1994, 08/339,663 filed November 11, 1994 and 08/373,446 filed January 17, 1995, the formed seamless image is explored, of which these are expressly incorporated by reference as to their entire contents. The exact representation of the transformation provided by this approach allows the seamless edges to be produced when the data is collected in a controlled manner.

Consequently, a method of capturing immersive images for stereoscopic display  
15 is claimed comprising the steps of: mounting an offset mounting means to a support means at a first end of the offset mounting means; mounting an image capture means to a second end of the offset mounting means and rotating the offset mounting means so that the image capture means is in a first position; rotating the offset mounting means through a first series of positions in a constant direction; capturing an immersive image with the  
20 image capture means at each of the series of positions such that the immersive images cover a 360 degree field-of-view; converting each of the captured immersive images into a first digital data image for each of the series of first positions; creating a first totally immersive representation; storing the first totally immersive representation in memory; rotating the offset mounting means so that the image capture means is in a second  
25 position, wherein the second position is 180 degrees apart from the first position; rotating the offset mounting means through a second series of positions in the constant direction; capturing an immersive image with the camera input means at each of the series of positions such that the immersive images cover a 360 degree field-of-view; converting  
30 each of the captured immersive images into a second digital data image for each of the series of second positions; creating a second totally immersive representation; and storing

the totally immersive representation in memory.

Consequently, a camera mounting apparatus for use in capturing totally immersive stereoscopic images is claimed that comprises: an n-stop rotator means having a top end and a bottom end; an eccentric mount means having a top side, a bottom side, a first end, and a second end, wherein the bottom side of the first end of the eccentric mount means is rigidly attached to the top end of the n-stop rotator means; a two-stop rotator means having a top end and a bottom end, wherein the bottom end of the two-stop rotator means is rigidly attached to the top side of the second end of the eccentric mount means; and a lens mount means having a bottom side, wherein the bottom side of the lens mount means is rigidly attached to the top end of the two-stop rotator means.

Consequently, a system for capturing immersive images for stereoscopic display is claimed comprising: an image capture means for capturing immersive images; an offset mounting means for mounting said image capture means thereon; a support means for mounting said offset mounting means thereon; an image receiving means for receiving said captured immersive images from said camera input means; a conversion means for converting said captured immersive images into digital data images; a storage means for storing said digital data images in memory; a processing means for creating two totally immersive representations from said digital data images, one for each eye; an associating means for associating said totally immersive representations as a pair; a transformation means for transforming a portion of said totally immersive representation with distortion and perspective correction; and a stereoscopic display means for displaying said two totally immersive representations independently to each eye of a user.

Consequently, a method of displaying totally immersive representations is claimed comprising the steps of: transforming portions of a first totally immersive representation and a second totally immersive representation with distortion and perspective correction, wherein the transforming portions step comprises the steps of: reading even lines from a first totally immersive representation digital image file, sending said even lines to a transformer for transforming said even lines into a right eye image, reading odd lines from a second totally immersive representation digital image file, and sending said odd lines to a transformer for transforming said odd lines into a left eye image; displaying said

transformed portions, wherein said displaying each said transformed portion step further comprises the steps of: selecting a stereoscopic display device for receiving said portions, said stereoscopic display device being selected from, but not limited to, the group comprising: independent miniature displays head mounted for each eye, displays with  
5 polarized filters that direct independent monitor images to each eye, color filters that direct stereo images to each eye through color mapping, and sequential shuttered glasses that alternately display every image to alternating eyes allowing the left eye to receive the left eye image and then the right eye to receive the right eye image, in rapid succession; and receiving said portions from said totally immersive representations in said stereoscopic  
10 display device.

Consequently, a method of capturing immersive images for stereoscopic display is claimed comprising the steps of mounting an image capture means on an offset mounting means; rotating the offset mounting means through a series of positions in a constant direction; capturing an immersive image with the image capture means at each  
15 of the series of positions; converting the captured immersive images into digital data images; creating two totally immersive representations from the digital data images, one for each eye, and digitally storing the totally immersive representations in memory; transforming a portion of the totally immersive representation with distortion and perspective correction; and displaying the two totally immersive representations  
20 independently to each eye of a user.

#### **Brief Description of the Drawings**

In the drawings,

Figure 1A illustrates a front view of one embodiment of the stereoscopic image capture system.

25 Figure 1B illustrates a side view of one embodiment of the stereoscopic image capture system.

Figure 2A illustrates a diagram of the image orientations and the order for the steps in the image capture process.

30 Figure 2B illustrates the right image digitization process and right totally immersive representation creation process.

Figure 2C illustrates the left image digitization process and left totally immersive representation creation process.

Figure 3 illustrates a flowchart of the steps in the image file display process.

5 Figure 4 illustrates an embodiment of a display in which the inventive method may be practiced and which is exemplary of other displays in which the inventive method may also be practiced.

Figure 5A illustrates one embodiment of the offset mounting system.

Figure 5B illustrates a side-perspective view of the lens mount.

10 Figure 5C illustrates a cut-away top view of the connection between the lens mount and the two-stop rotator.

Figure 5D illustrates a partial cross-section of the two-stop rotator that shows the structure of the positioning elements and central bore.

Figure 5E illustrates a bottom view of the top-half and top view of the bottom-half of the two-stop rotator.

15 Figure 5F illustrates a bottom view of the top-half and top view of the bottom-half of the n-stop rotator.

Figure 5G illustrates a partial cut-away view of the top side of eccentric mount at the n-stop rotator end..

Figure 6 illustrates an alternative embodiment of the offset mounting system.

20 **Detailed Description**

FIG. 1A shows a front view of the stereoscopic image capture system 100 as contemplated by embodiments of the present invention. System 100 includes an image capture means 110 securely mounted to an offset mounting means 120 and offset mounting means 120 is mounted to a support means 190. Image capture means 110 consists of a camera 112 with a lens 114 securely mounted to the camera 112. Embodiments of the present invention contemplate the camera 112 as a still camera taking chemical or digital pictures, or a video camera capturing video images. In one embodiment, the lens 114 is a wide-angle lens. Other embodiments of the present invention contemplate the lens 114 including the lens types of: fish-eye, hemispherical, and greater than hemispherical types of lenses. Embodiments of the present invention

25  
30

contemplate the support means 190 including stable base structures such as tripods and tripod-monopod combinations. Offset mounting means 120 consists of a lens mount 141 that securely attaches to a top-half 144 of a two-stop rotator 132. The top-half 144 of the two-stop rotator 132 is rotably connected to a bottom-half 147 of the two-stop rotator 132. The bottom-half 147 of the two-stop rotator 132 securely attaches on the top-side of a first end of an eccentric mount 150. The bottom-side of a second end of the eccentric mount 150 securely attaches to a top-half 153 of an n-stop rotator 135, where n is a number greater than one. The top-half 153 of the n-stop rotator 135 is rotably connected to a bottom-half 156 of the n-stop rotator 135. The bottom-half 156 of n-stop rotator 135 is mounted on a support means 190. two-stop rotator 132 and n-stop rotator 135 are separated by an inter-device distance  $d_1$ , for example, simulating the average interpupillary distance of human eyes. In one embodiment, the inter-device distance  $d_1$  is approximately 3 inches.

Embodiments of the present invention contemplate the two-stop and n-stop rotators 132 and 135, respectively, including a low friction layer between the contacting surfaces of the top-half 144 and bottom-half 146 of two-stop rotator 132 and between the top-half 153 and bottom-half 156 of n-stop rotator 135. This low friction layer preferably includes at least one Teflon TM (or equivalent) disk. Alternative embodiments of the two-stop and n-stop rotators 132 and 135, respectively, include bearings, a fluid filled enclosure, and coated surfaces. In one embodiment, the lens mount 141, two-stop rotator 132, eccentric mount 150, n-stop rotator 135, and support means 190 are made of aluminum and/or anodized aluminum.

By rotating the top-half 144 of two-stop rotator 132 180 degrees, the lens 114 points in a direction opposite from its initial direction. Positioning devices (see FIG. 5 description) between top-half 144 and bottom-half 147 of two-stop rotator 132 securely maintain lens 114 in a first position and in a second, opposite position, where the first and second positions differ by 180 degrees. Accordingly, a user wishing to capture two oppositely directed images photographs a first image with the camera 112 in a first position, rotates the top-half 144 of the two-stop rotator 132 until the camera 112 is oriented in a second position, which is 180 degrees apart from the first position, and

photographs a second image.

FIG. 1B illustrates a side view of the stereoscopic image capture system 100 illustrated in FIG. 1A.

FIG. 2A shows the images captured by the stereo image capture process of the present invention. In FIG. 2, an embodiment is shown for capturing images every 90 degrees with the stereoscopic image capture system 100 being centered at point 210. In this embodiment, the center of stereoscopic image capture system 100 is the center of n-stop rotator 135 and the center of image capture means 110 is the center of two-stop rotator 132. Offset mounting means 120 is first offset to the right of center 210 so that image capture means 110 is centered over right position 212 and lens 114 is oriented toward right 1 image 220. Right 1 image 220 is captured using image capture means 110. Offset mounting means 120 is then rotated 90 degrees in a counter-clockwise direction so that image capture means 110 is centered over top position 214 with camera lens 114 oriented toward right 2 image 230. Right 2 image 230 is captured using image capture means 110. Offset mounting means 120 is again rotated 90 degrees in a counter-clockwise direction so that image capture means 110 is centered over left position 216 with lens 114 oriented toward right 3 image 240. Right 3 image 240 is captured using image capture means 110. Offset mounting means 120 is rotated a final 90 degrees in a counter-clockwise direction so that image capture means 110 is centered over bottom position 218 with lens 114 oriented toward right 4 image 250. Right 4 image 250 is captured using image capture means 110.

FIG. 2B shows right 1, 2, 3, and 4 images 220, 230, 240, and 250, respectively, are sent through an Analog-to-Digital (A/D) converter 201 and digitized into right 1, 2, 3, and 4 digital images 220', 230', 240', and 250', respectively. Then, all of the right digital images 220', 230', 240', and 250 are combined into a right eye totally immersive representation 292. The right eye totally immersive representation 292 is then stored in a right eye file 294 for future display. While the order of image capture and the direction of rotation of the offset mounting means 120 can be varied in alternate embodiments of the present invention, this will require additional manual operator intervention and a more complex processing system. The order and constant direction specified in this

embodiment of the present invention has been selected to maximize the efficiency of the image capture and totally immersive representation creation processes. The constant direction specified in this embodiment could have also been clockwise.

A similar set of steps are followed to capture the left eye images. Offset mounting means 120 is first offset to the left of center 210 so that image capture means 110 is centered over left position 216 and lens 114 is oriented toward left 1 image 260. Left 1 image 260 is captured using image capture means 110. Offset mounting means 120 is then rotated 90 degrees in a counter-clockwise direction so that image capture means 110 is centered over bottom position 218 with lens 114 oriented toward left 2 image 270. Left 2 image 270 is captured using image capture means 110. Offset mounting means 120 is again rotated 90 degrees in a counter-clockwise direction so that image capture means 110 is centered over right position 212 with lens 114 oriented toward left 3 image 280. Left 3 image 280 is captured using image capture means 110. Offset mounting means 120 is rotated a final 90 degrees in a counter-clockwise direction so that image capture means 110 is centered over top position 214 with lens 114 oriented toward left 4 image 290. Left 4 image 290 is captured using image capture means 110.

FIG. 2C shows left 1, 2, 3, and 4 images 260, 270, 280, and 290, respectively, are sent through the A/D converter 201 and digitized into left 1, 2, 3, and 4 digital images 260', 270', 280', and 290', respectively. Then, all of the left digital images 260', 270', 280', and 290' are combined into a left eye totally immersive representation 296. The left eye totally immersive representation 296 is then stored in a left eye file 298 for future display.

The creation of the right and left totally immersive representations 292 and 296, respectively, and subsequent storage in right and left eye files 294 and 298 296, respectively, create images that are internally seamless and perfectly aligned. Similarly, the points in the right eye file 294 and the left eye file 298 are also perfectly aligned so as to provide the correct perspective view for each eye. This is important for accurate and realistic stereoscopic displays of the stored images to a user's left and right eyes.

Alternate embodiments can include capturing images at different offset angles, including, but not limited to: 180, 110, 72, 60, 45, 40, 36, and 30 degrees. In another embodiment, images could also be captured in the up and down directions either

independent of or in combination with the left and right images.

FIG. 3 shows a flowchart of the steps performed in one embodiment of the stereoscopic image file display process. In FIG. 3, the right eye file 294 and left eye file 298 information are alternately output through right eye connection 310 and left eye connection 320 to input connection 332 for gnostic transformer 330. Gnostic transformer 330 produces an interlaced stereo image by interlacing the right eye file 294 information into the even numbered lines and the left eye file 298 information into the odd numbered lines of the interlaced stereo image. Interlacing of the image data is accomplished by feedback loop 334, which outputs the number of the next line in the image, and, if it is an even number, then input connection 332 switches to right eye connection 310 to receive the next line of image data. Similarly, if the output line number is an odd number, then input connection 332 switches to left eye connection 320 to receive the next line of image data. This interlaced stereo image is then sent to a stereo interlaced output buffer 340. In one embodiment, stereo interlaced output buffer 340 outputs the stereo image as an interlaced display signal 335 to a Digital-to-Analog (D/A) converter 350 which converts interlaced display signal 335 to an analog signal and then transmits the analog signal to a display.

FIG. 4 shows one embodiment of a stereo display apparatus in which the inventive method may be practiced and which is exemplary of other displays in which the inventive method may also be practiced. In FIG. 4, the interlaced display signal 335 is output from stereo interlaced output buffer 340 to an image splitter 410. Image splitter 410 splits out the even and odd lines from the interlaced display signal 335 and sends the even lines via output connection 415 to a right eye display connection 420 to a right eye display 442 and sends the odd lines via output connection 415 to a left eye display connection 430 to the left eye display 444 of a miniature head mounted display 440. Output connection 415 switches between right eye display connection 420 and left eye display connection 430 based on the line number of the next line to be output. For example, if the next line to be output is an even number then output connection 415 switches to the right eye display connection 420, and if the next line to be output is an odd number then output connection 415 switches to the left eye display connection 430. Alternative stereo displays include,

but are not limited to, the following: dual displays; independent miniature displays head mounted for each eye; displays with polarized filters that direct independent monitor images to each eye; color filters that direct stereo images to each eye through color mapping; and sequential shuttered glasses that alternately display every image to  
5 alternating eyes allowing the left eye to receive the left eye image and then the right eye to receive the right eye image, in rapid succession.

FIG. 5A shows one embodiment of offset mounting means 120. In FIG 5A, offset mounting means 120 consists of a lens mount 141 with a lens mount bottom 142 that securely attaches to the top end 143 of the top-half 144 of a two-stop rotator 132. The  
10 bottom end 145 of the top-half 144 of the two-stop rotator 132 is rotably connected to the top end 146 of the bottom-half 147 of the two-stop rotator 132 and the bottom end 148 of the bottom-half 147 of the two-stop rotator 132 securely attaches to a top side 149 at a first end of an eccentric mount 150. Bottom side 151, at a second end of the eccentric mount 150, securely attaches to a top end 152 of a top-half 153 of an n-stop  
15 rotator 135, a bottom end 154 of the top-half 153 of the n-stop rotator 135 is rotably connected to a top end 155 of a bottom-half 156 of the n-stop rotator 135. Bottom end 157 of bottom-half 156 of n-stop rotator 135 contains a support means mounting recess 178 for attaching the offset mounting means 120 to the support means 190. The surface of both top-half 144 and bottom-half 147 can have a grooved areas to provide easier  
20 grasping by a user when rotating the two-stop rotator 132. Likewise, the grooved areas could be knurled, bumped, or some other grip enhancing structure in other embodiments.

FIG. 5B provides a side-perspective view of lens mount 141. In FIG. 5B, lens mount 141 comprises an outer surface 183, an inner surface 184, an image side 189, and a back side (not shown). Lens mount 141 is a substantially complete annular ring having  
25 an opening 188 that extends the across the width of image side 189 and extending between inner and outer surfaces 184 and 183, respectively, to create upper and lower portions of lens mount 141. Fastening screw 185 is recessed downward through recessing slot 186 on outer surface 183 in the upper portion of lens mount 141, passing through opening 188, and into the lower portion of lens mount 141 having a screw recess 187 for  
30 receiving the fastening screw 185. In the present embodiment opening 188 is disposed

at an approximately 90 degree angle from lens mount bottom 142. Lens mount bottom 142 is a flat section on the lower portion of outer surface 183. Fastening screw 185 is loosened to permit installation of lens 114 (not shown) and tightened to close opening 188 to securely hold lens 114. Alternate embodiments of the lens mount are disclosed in co-  
5 pending U.S. Application Serial No. 08/767,376 which is incorporated by reference herein in its entirety.

Embodiments of the present invention contemplate the two-stop and n-stop rotators 132 and 135, respectively, including a low friction layer between the contacting surfaces of top-half 144 of two-stop rotator 132 and bottom-half 147 of two-stop rotator  
10 132 and between top-half 153 of n-stop rotator 135 and bottom-half 156 of n-stop rotator 135. This low friction layer preferably includes at least one Teflon TM (or equivalent) disk. Alternative embodiments of the two-stop and n-stop rotators 132 and 135, respectively, include bearings, a fluid filled enclosure, and coated surfaces. In one embodiment, the lens mount 141, two-stop rotator 132, eccentric mount 150, n-stop  
15 rotator 135, and support means 190 are made of aluminum and/or anodized aluminum.

FIG. 5C show a cut-away top view of the connection of lens mount 141 and top end 143 of top-half 144 of two-stop rotator 132. Lens mount 141 has a pair of screws 181 recessed through inner surface 184, extending through lens mount bottom 142 and into top end 143 of top-half 144 of 2 stop-rotator 132 to securely fasten lens mount 141  
20 to top end 143. Bottom lip 170 is attached to image side 189 of lens mount 141 with the bottom edge of bottom lip 170 being aligned with and extending along lens mount bottom 142. Bottom lip 170 extends from the lens mount bottom 142 along image side 189 with the top edge of bottom lip 170 extending a short distance past inner surface 184. The top edge of bottom lip 170 is curved in substantially the same arc as inner surface 184.  
25 Bottom lip 170 is centered over top end 143 and recessed screw 182. Top lip 171 is similarly attached to image side 189 of lens mount 141 with top edge of top lip 171 being substantially aligned with outer surface 183 at a point essentially 180 degrees from bottom lip 170. Top lip 171 extends downward from outer surface 183 along image side 189 with the bottom edge of top lip 171 extending a short distance past inner surface 184.  
30 Alternate embodiments for lips include, but are not limited to: a single continuous lip and

more than two lips equally arranged around image side 189.

Referring again to FIG. 5A, recessed screw 182 extends from top end 143 of top-half 144 of two-stop rotator 132 downward through bottom end 145 of top-half 144 and into two-stop rotator central bore 122 where it terminates and operates to rotably connect  
5 top-half 144 and bottom-half 147 of two-stop rotator 132. FIG. 5A also shows screw 180 passing through washer 179 and bottom side 152 at a first end of eccentric mount 150 and into bottom end 148 of bottom-half 147 of two-stop rotator 132 to securely fasten two-stop rotator 132 to eccentric mount 150.

FIG 5D is a partial cross-section of two-stop rotator 132 along line A and shows  
10 the internal structure of the two-stop rotator 132 positioning elements. In the present embodiment, bottom end 145 of top-half 144 contains two recesses 177 positioned 180 degrees apart along the center line of bottom end 145. Springs 178 are positioned in recesses 177, ball bearings 175 are positioned on top of the springs 178, and bottom-half 147 is fastened to top-half 144 so that top end 146 of bottom-half 147 contact ball  
15 bearings 175 and strain springs 178 into recesses 177. The strain on springs 178 creates a force that constantly pushes ball bearings 175 against top end 146 of bottom-half 147. In the present embodiment, top-half 144 is fastened to bottom-half 147 by inserting fastening screw 182 through top end 143 of top-half 144 and into central bore 122 that extends from bottom-half 147. Referring now to FIG. 5E, as ball bearings 175 slide into  
20 curved indents 176 on top end 146 of bottom-half 147 the force exerted by the strained springs holds the ball bearings 175, and, thus, two-stop rotator 132 in place. Significant force must be exerted to move the ball bearings 175 out of the curved indents 176 in order to rotate the two-stop rotator 132. The on-center distance  $d$  between recesses 177 is equal to the on-center distance between curved indents 176. In addition, recesses 177 and  
25 curved indents 176 are aligned along the center line of two-stop rotator 132. In an alternate embodiment with an odd number of recesses and curved indents, the recesses and curved indents would have equidistant radii from the center point of the two-stop rotator 132 and be at equal offset angles, for example, radii equal to .5 inches and the offset angles equal to 110 degrees for a 3-stop rotator.

30 FIG. 5F shows the four recesses 177 and curved indents 176 of the current

embodiment of the n-stop rotator 135. The operation is consistent with that described above for two-stop rotator 132 and alternate embodiments with odd numbers of recesses and curved indents.

5 FIG. 5G shows a partial cut-away view of top side 149 at a second end of eccentric mount 150. Screws 161 are recessed into and through eccentric mount 150 through recessed screw holes 160 and into top end 152 of top-half 153 of n-stop rotator 135. Recessed screw holes 160 are parallel to and offset from the center line of n-stop rotator 135. Eccentric mount 150 also has locator pin holes 162 to receive locator pins 163. Locator pins 163 extend through eccentric mount 150 and into top end 152 of top-half 153 of n-stop rotator 135.  
10

FIG. 6 shows an alternate embodiment of the offset camera platform means 500. In this embodiment, the angled eccentric mount 150 of FIG. 5 is replaced with a straight eccentric mount 610. All other elements are identical to those described above for FIG. 5A. Another alternate embodiment would replace the angled eccentric mount 150 of FIG. 5A with a centered straight mount so that equal lengths of the straight mount extend past the n-stop rotator 135. In addition, the straight mount would permit the two-stop rotator 132 to slide from side-to-side.  
15

What has been described is merely illustrative of the application of the principles of the present invention. Other arrangements and methods can be implemented by those skilled in the art without departing from the spirit and scope of the present invention.  
20

All U.S. Patent Applications referenced herein shall be deemed to be incorporated by reference as to their entire contents.

**AMENDED CLAIMS**

[received by the International Bureau on 26 March 1999 (26.03.99);  
original claims 10, 17-19 and 22 amended;  
new claim 23 added; remaining claims unchanged (7 pages)]

1. **A method of capturing immersive images for stereoscopic display comprising the steps of:**

5 **mounting an offset mounting means to a support means at a first end of said offset mounting means;**

**mounting an image capture means to a second end of said offset mounting means and rotating said offset mounting means so that said image capture means is in a first position;**

**rotating said offset mounting means through a first series of positions in a constant direction;**

10 **capturing an immersive image with said image capture means at each of said series of positions such that said immersive images cover a 360 degree field-of-view;**

**converting each of said captured immersive images into a first digital data image for each of said series of first positions;**

**creating a first totally immersive representation;**

15 **storing said first totally immersive representation in memory;**

**rotating said offset mounting means so that said image capture means is in a second position, wherein said second position is 180 degrees apart from said first position;**

**rotating said offset mounting means through a second series of positions in said constant direction;**

20 **capturing an immersive image with said camera input means at each of said series of positions such that said immersive images cover a 360 degree field-of-view;**

**converting each of said captured immersive images into a second digital data image for each of said series of second positions;**

**creating a second totally immersive representation; and**

25 **storing said totally immersive representation in memory.**

2. **The method of capturing immersive images for stereoscopic display according to claim 1 wherein said image capture means comprises video or still image camera systems.**

3. The method of capturing immersive images for stereoscopic display according to claim 2 wherein said video or still image camera systems comprise digital and film cameras.

4. The method of capturing immersive images for stereoscopic display according to claim 1 wherein said image capture means comprises:

5 a camera; and  
a fisheye or wide-angle lens attached to said camera.

5. The method of capturing immersive images for stereoscopic display according to claim 1 wherein said creating a first totally immersive representation step further comprises the step of:

10 combining said first digital data images for each of said series of first positions into said first totally immersive representation, so that said first totally immersive representation is a seamless image.

6. The method of capturing immersive images for stereoscopic display according to claim 1 wherein said transforming a portion of said totally immersive representation step further comprises the step of:

15 transforming said portion based on user input.

7. The method of capturing immersive images for stereoscopic display according to claim 6 wherein said user input comprises:

20 pan, tilt, and zoom.

8. A camera mounting apparatus for use in capturing totally immersive stereoscopic images comprising:

an n-stop rotator means having a top end and a bottom end;

25 an eccentric mount means having a top side, a bottom side, a first end, and a second end, wherein said bottom side of said first end of said eccentric mount means is

rigidly attached to said top end of said n-stop rotator means;

a two-stop rotator means having a top end and a bottom end, wherein said bottom end of said two-stop rotator means is rigidly attached to said top side of said second end of said eccentric mount means; and

5 a lens mount means having a bottom side, wherein said bottom side of said lens mount means is rigidly attached to said top end of said two-stop rotator means.

9. The apparatus recited in claim 8, wherein said n-stop rotator means comprises:

a top-half;

a bottom-half, said bottom-half being rotably connected to said top-half; and

10 a rotator means disposed between said top-half and said bottom-half for rotating said top-half around said bottom-half.

10. The apparatus recited in claim 9, wherein said rotator means comprises:

a pair of springs;

a pair of ball bearings;

15 said top-half having a bottom end with a pair of recesses to first receive said pair of springs and then receive said pair of ball bearings; and

said bottom-half having a top end a pair of indents, said indents sized so as to allow said ball bearings to rest within said indents;

20 wherein said pair of indents and said pair of recesses will be coincident in two, 180 degree apart, positions of said rotably connected bottom-half and top-half of said two-stop rotator.

11. A system for capturing immersive images for stereoscopic display comprising:

an image capture means for capturing immersive images;

an offset mounting means for mounting said image capture means thereon;

25 a support means for mounting said offset mounting means thereon;

an image receiving means for receiving said captured immersive images from said

camera input means;

a conversion means for converting said captured immersive images into digital data images;

a storage means for storing said digital data images in memory;

5 a processing means for creating two totally immersive representations from said digital data images, one for each eye;

an associating means for associating said totally immersive representations as a pair;

a transformation means for transforming a portion of said totally immersive representation with distortion and perspective correction; and

10 a stereoscopic display means for displaying said two totally immersive representations independently to each eye of a user.

12. The system recited in claim 11 wherein said offset mounting means comprises:

an n-stop rotator means having a top end and a bottom end;

15 an eccentric mount means having a top side, a bottom side, a first end, and a second end, wherein said bottom side of said first end of said eccentric mount means is rigidly attached to said top end of said n-stop rotator means;

a two-stop rotator means having a top end and a bottom end, wherein said bottom end of said two-stop rotator means is rigidly attached to said top side of said second end of said eccentric mount means; and

20 a lens mount means having a bottom side, wherein said bottom side of said lens mount means is rigidly attached to said top end of said two-stop rotator means.

13. The system for capturing immersive images for stereoscopic display according to claim 11 wherein said camera input means comprises video or still image camera systems.

25 14. The system for capturing immersive images for stereoscopic display according to claim 12 wherein said video or still image camera systems comprise digital and film cameras.

15. The system for capturing immersive images for stereoscopic display according to claim 11 wherein said camera input means further comprises a fisheye or a wide-angle lens.

5 16. The system for capturing immersive images for stereoscopic display according to claim 11 wherein said stereoscopic display means is selected from the group comprising:  
independent miniature displays head mounted for each eye;  
displays with polarized filters that direct independent monitor images to each eye;  
color filters that direct stereo images to each eye through color mapping; and  
10 sequential shuttered glasses that alternately display every image to alternating eyes allowing the left eye to receive the left eye image and then the right eye to receive the right eye image, in rapid succession.

17. A method of displaying totally immersive representations comprising the steps of:  
transforming portions of a first totally immersive representation and a second totally  
immersive representation with distortion and perspective correction; and  
15 displaying said transformed portions.

18. The method of displaying totally immersive representations recited in claim 17,  
wherein the transforming portions step comprises the steps of:  
20 reading even lines from a first totally immersive representation digital image file;  
sending said even lines to a transformer for transforming said even lines into a right  
eye image;  
reading odd lines from a second totally immersive representation digital image file; and  
sending said odd lines to a transformer for transforming said odd lines into a left eye  
image.

25 19. The method of displaying totally immersive representations recited in claim 18 wherein said displaying each said transformed portion step further comprises the steps of:  
selecting a stereoscopic display device for receiving said portions, said stereoscopic

display device being selected from, but not limited to, the group comprising:

independent miniature displays head mounted for each eye,

displays with polarized filters that direct independent monitor images to each eye,

color filters that direct stereo images to each eye through color mapping, and

5 sequential shuttered glasses that alternately display every image to alternating eyes allowing the left eye to receive the left eye image and then the right eye to receive the right eye image, in rapid succession; and

receiving said portions from said totally immersive representations in said stereoscopic display device.

10 20. The apparatus recited in claim 8, wherein said n-stop rotator is offset on said offset camera platform mount from said two-stop rotator by an offset distance representative of the standard inter-pupillary distance in human eyes.

21. The apparatus recited in claim 20, wherein said offset distance is approximately three inches from the center of said n-stop rotator to the center of said two-stop rotator.

15 22. A method of capturing immersive images for stereoscopic display comprising the steps of:

mounting an image capture means on an offset mounting means;

rotating said image capture means through a series of positions in a constant direction;

capturing an immersive image with said image capture means at each of said series of

20 positions;

converting said captured immersive images into digital data images;

creating two totally immersive representations from said digital data images, one for each eye, and digitally storing said totally immersive representations in memory;

25 transforming a portion of each of said two totally immersive representations with distortion and perspective correction; and

displaying said portions of said two totally immersive representations independently to each eye of a user.

23. A method of capturing immersive spherical images for stereoscopic display comprising the steps of:

5 mounting an offset mounting means to a support means at a first end of said offset mounting means;

mounting an image capture means to a second end of said offset mounting means and rotating said offset mounting means so that said image capture means is in a first position;

10 rotating said offset mounting means through a first series of positions in a constant direction;

capturing an immersive image with said image capture means at each of said series of positions such that said immersive images cover a 360-degree hemispherical field-of-view;

converting each of said captured immersive images into a first digital data image for each of said series of first positions;

15 creating a first totally immersive representation from said first digital data images; storing said first totally immersive representation in memory;

rotating said offset mounting means so that said image capture means is in a second position, wherein said second position is 180 degrees apart from said first position;

20 rotating said offset mounting means through a second series of positions in said constant direction;

capturing an immersive image with said camera input means at each of said series of positions such that said immersive images cover a 360-degree hemispherical field-of-view;

converting each of said captured immersive images into a second digital data image for each of said series of second positions;

25 creating a second totally immersive representation from said second digital data images; and

storing said totally immersive representation in memory.

**FIG. 1B**

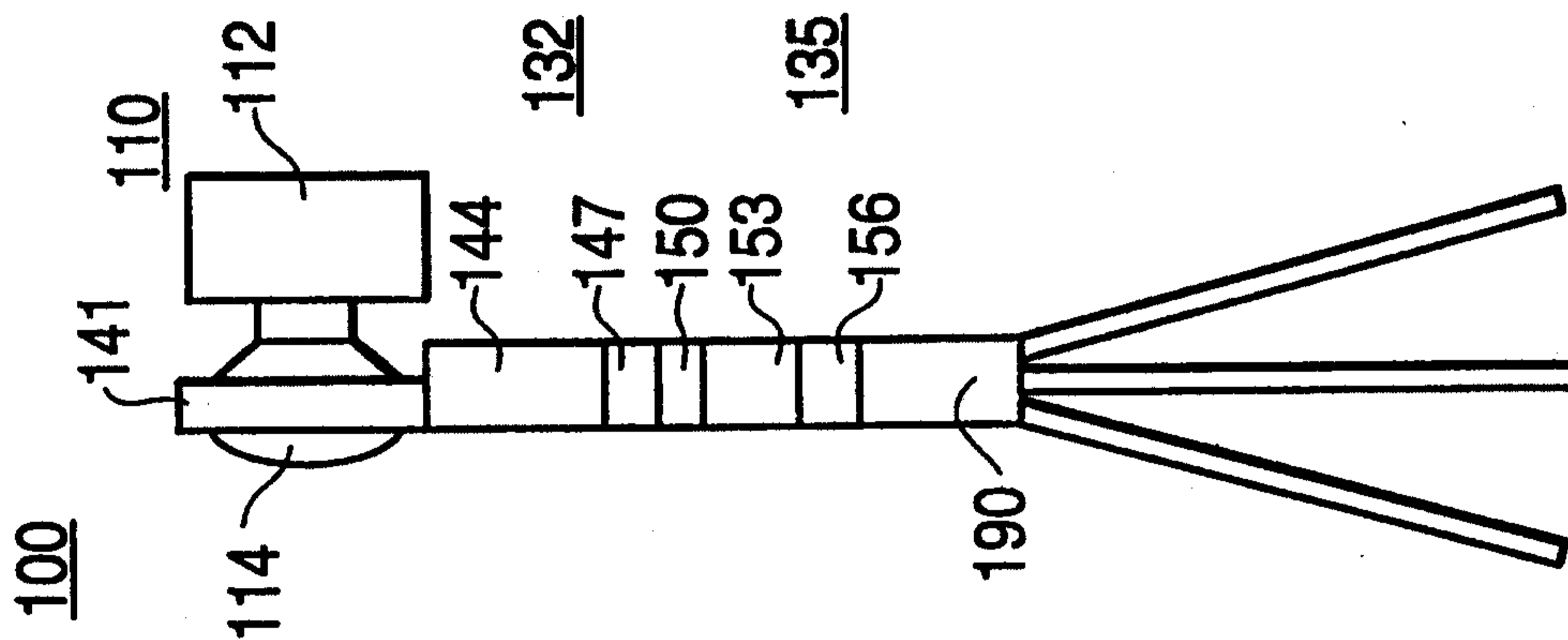

**FIG. 1A**

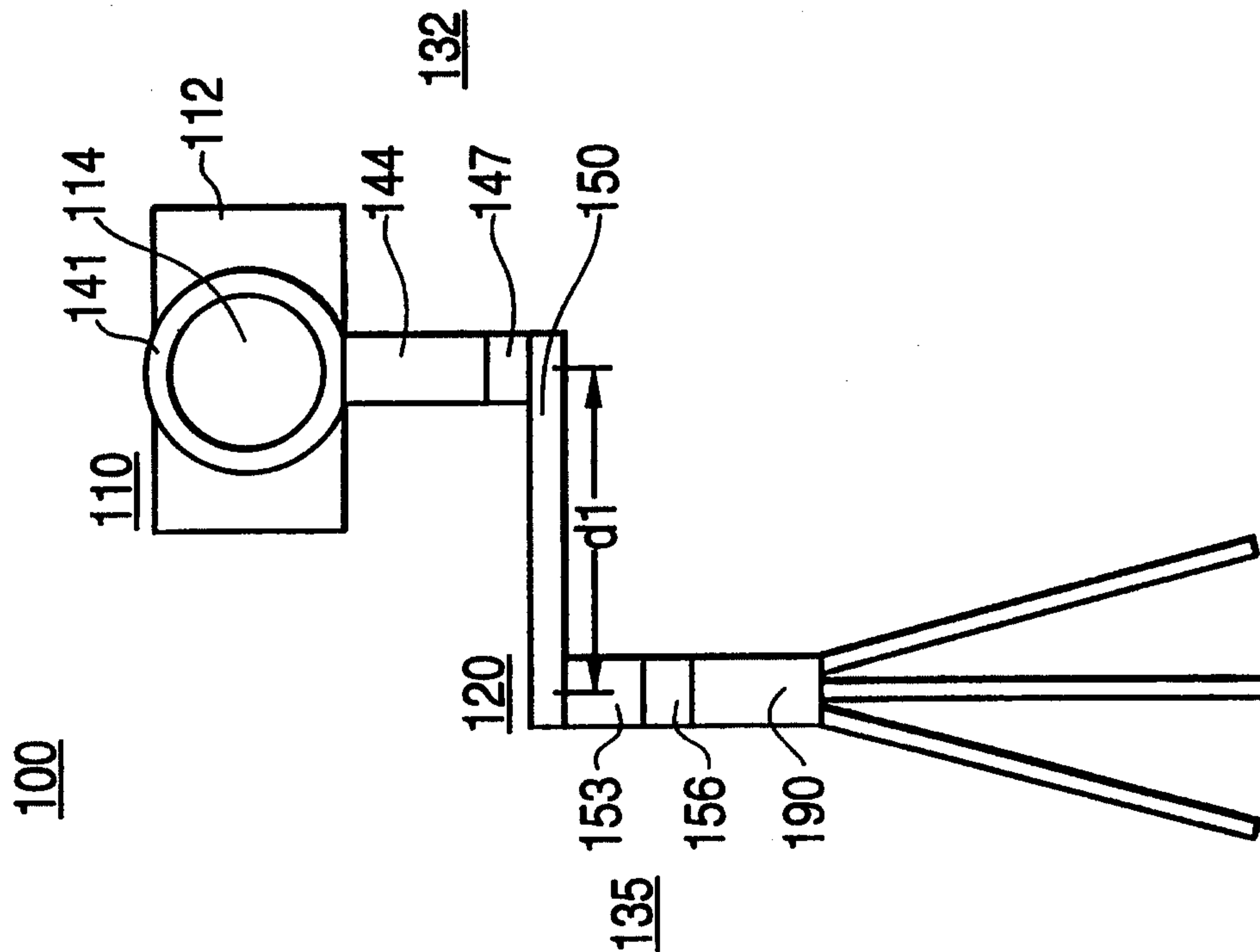

FIG. 2A

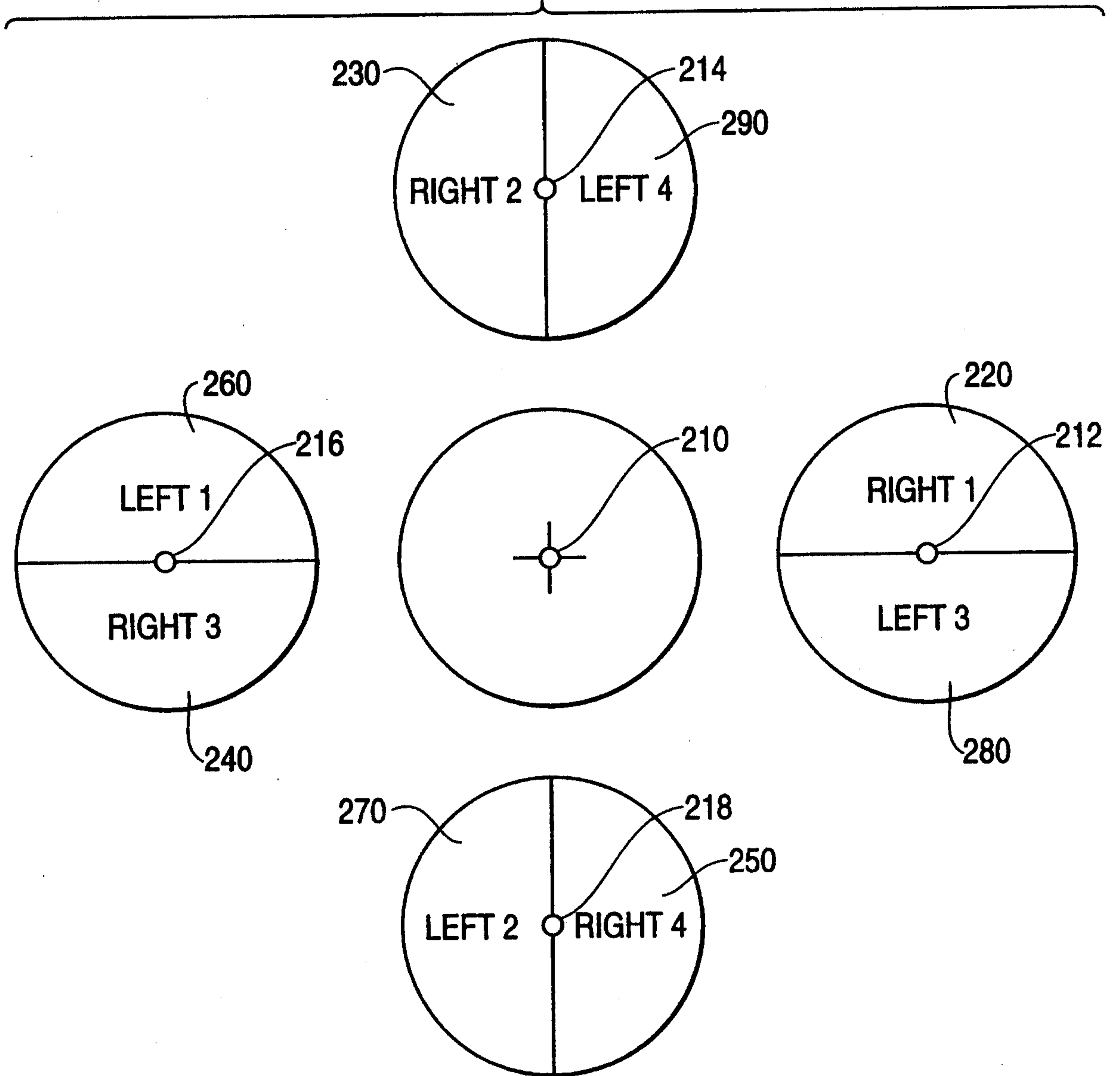

FIG. 2B

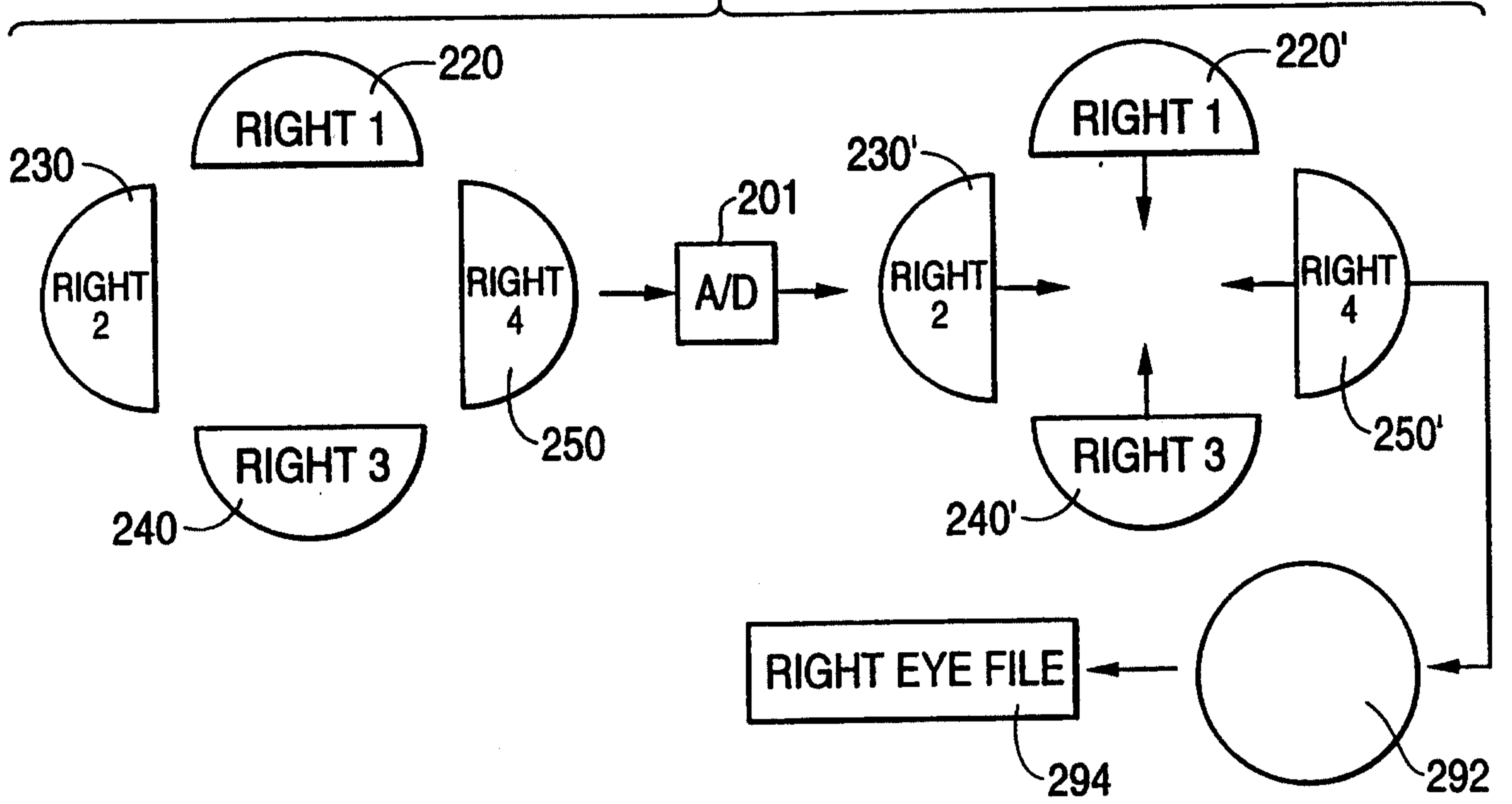
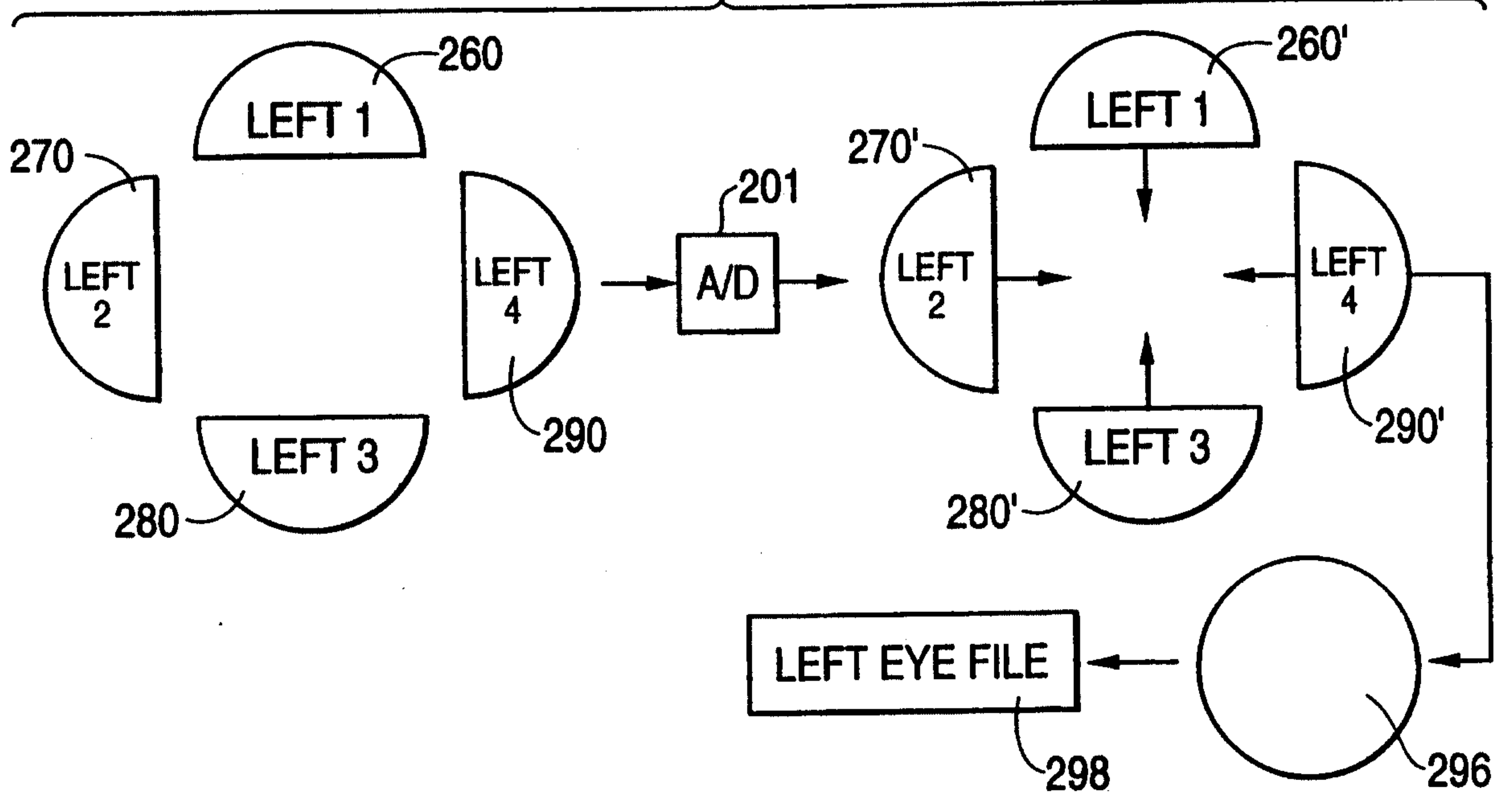
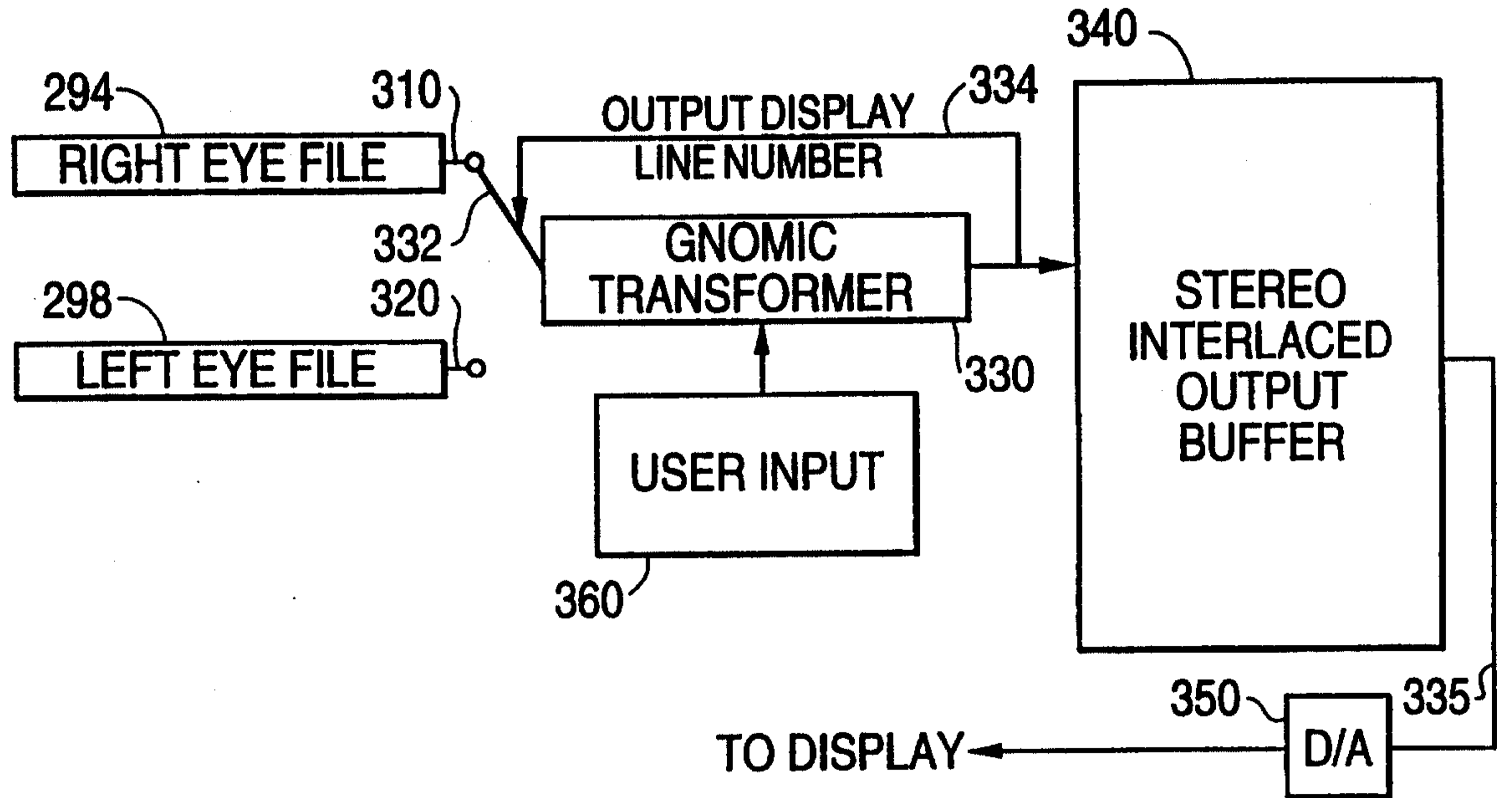

FIG. 2C



**FIG. 3**



**FIG. 4**

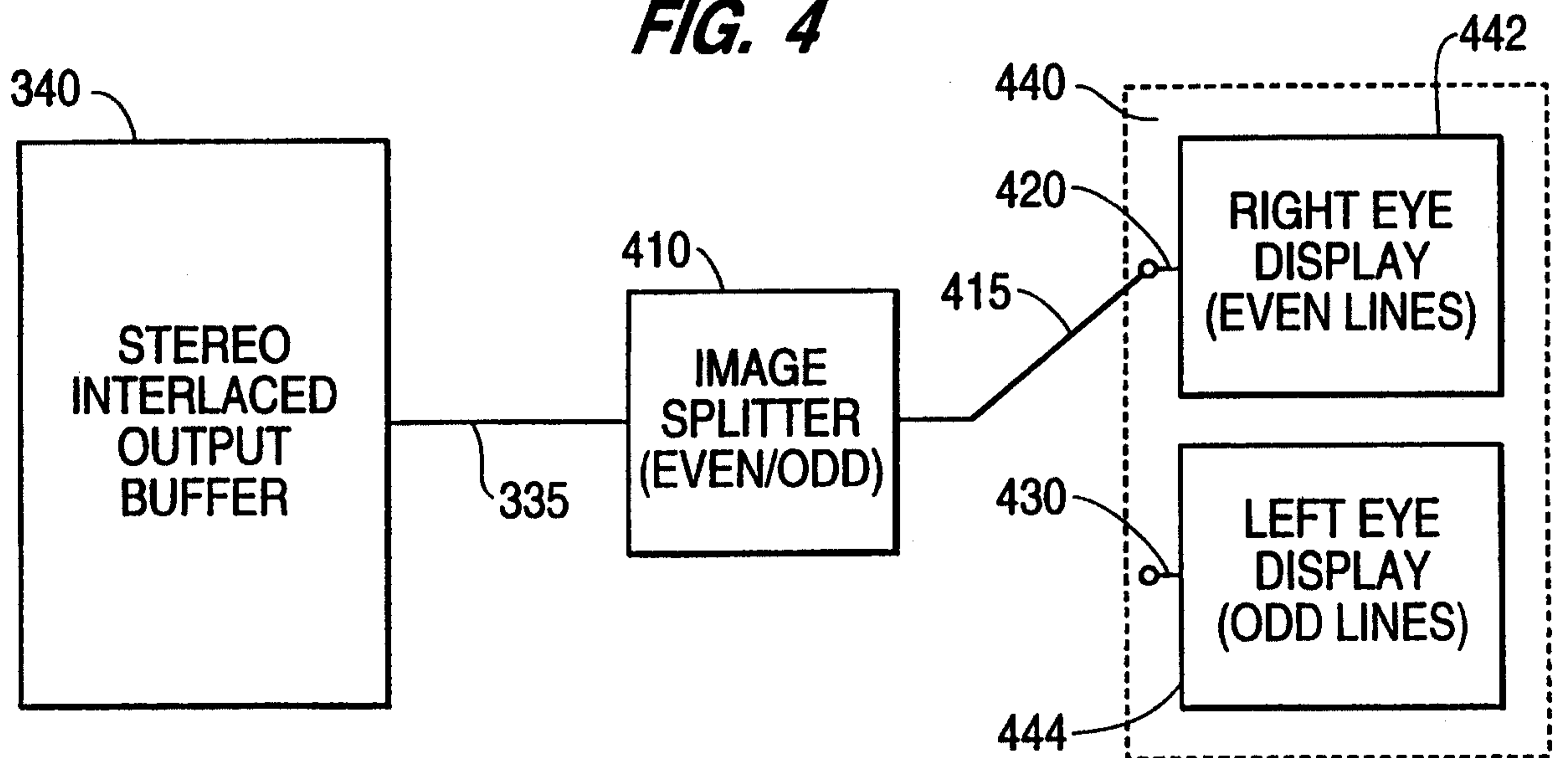

**FIG. 5A**

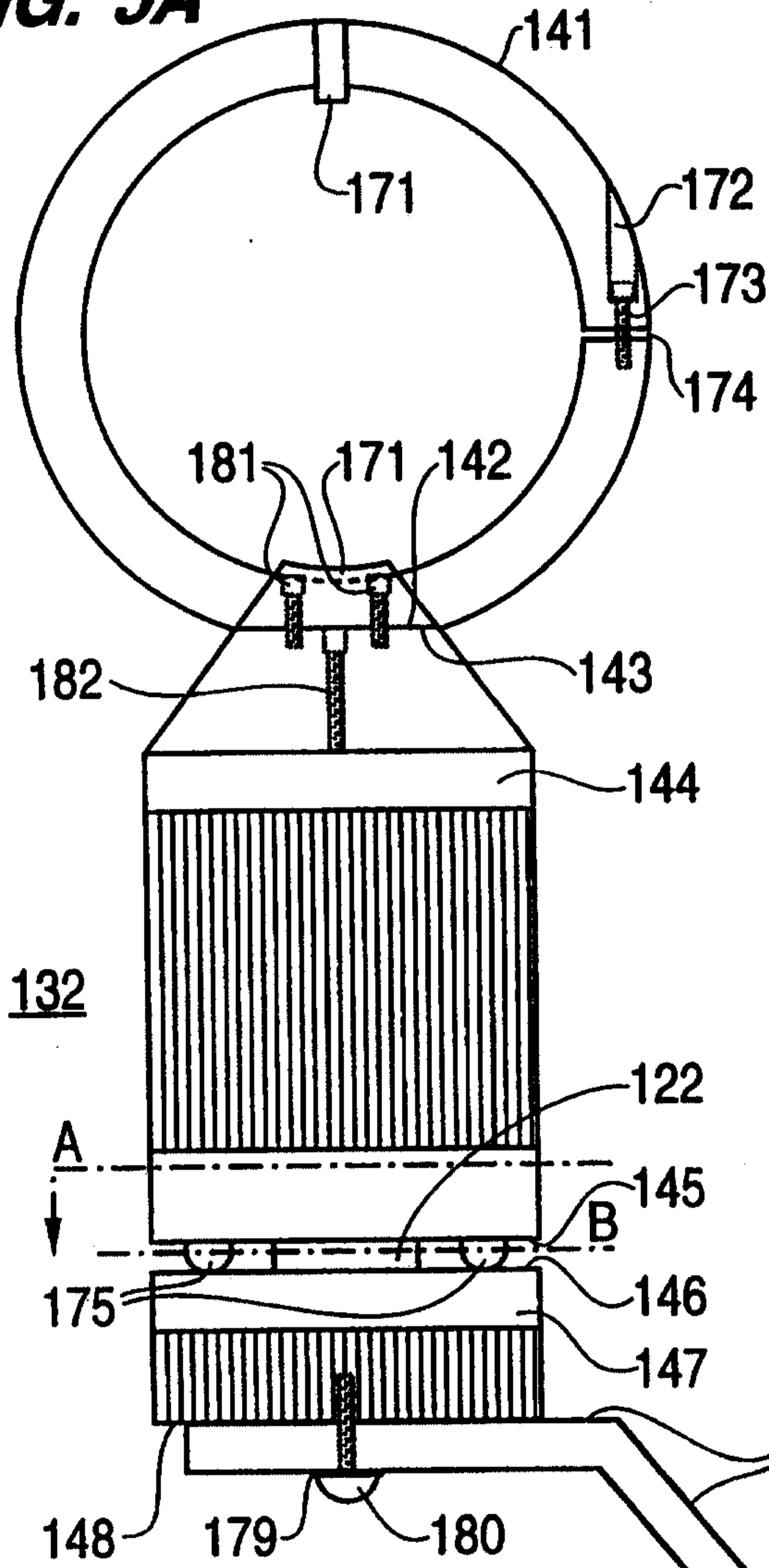

**FIG. 5B**

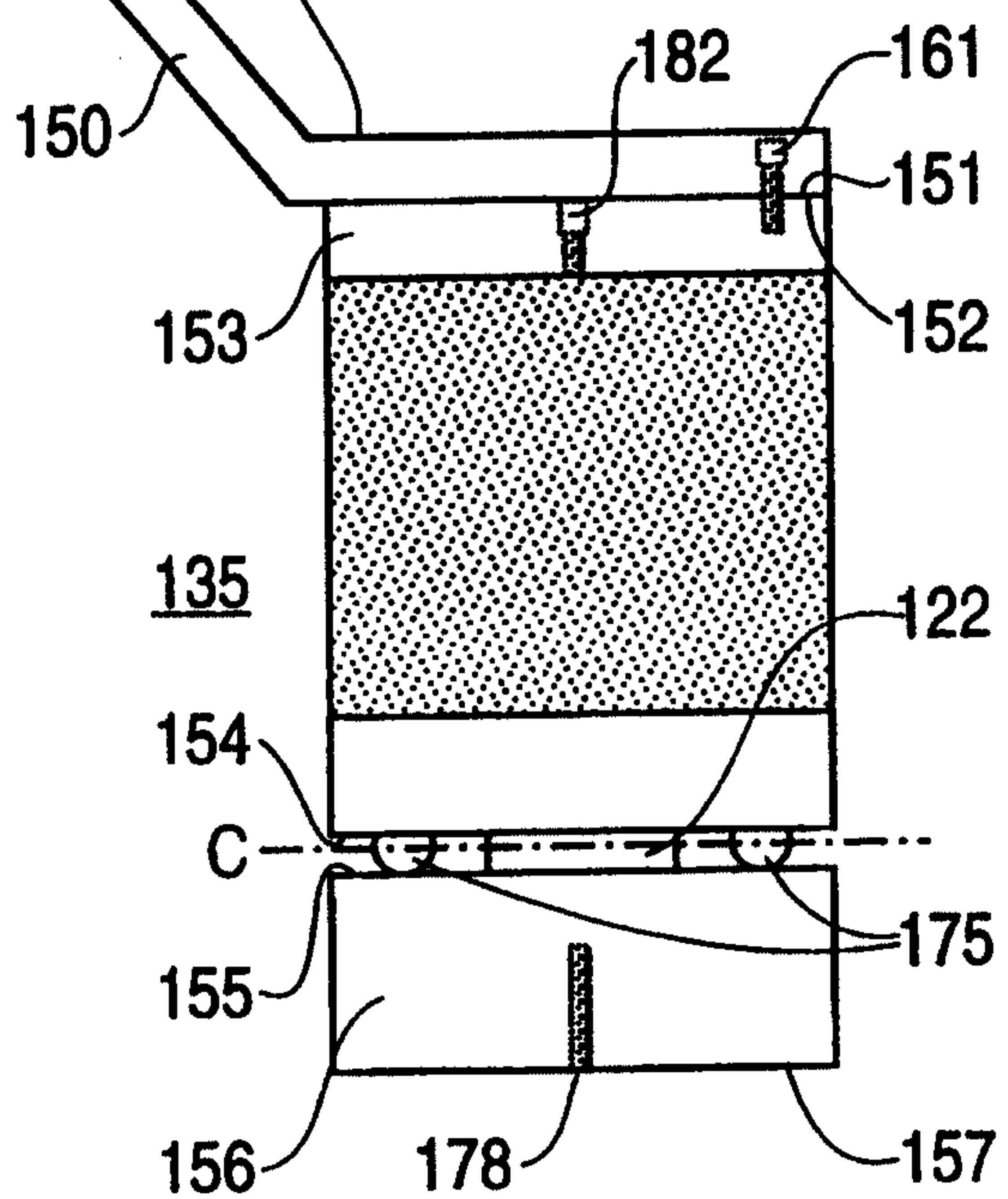
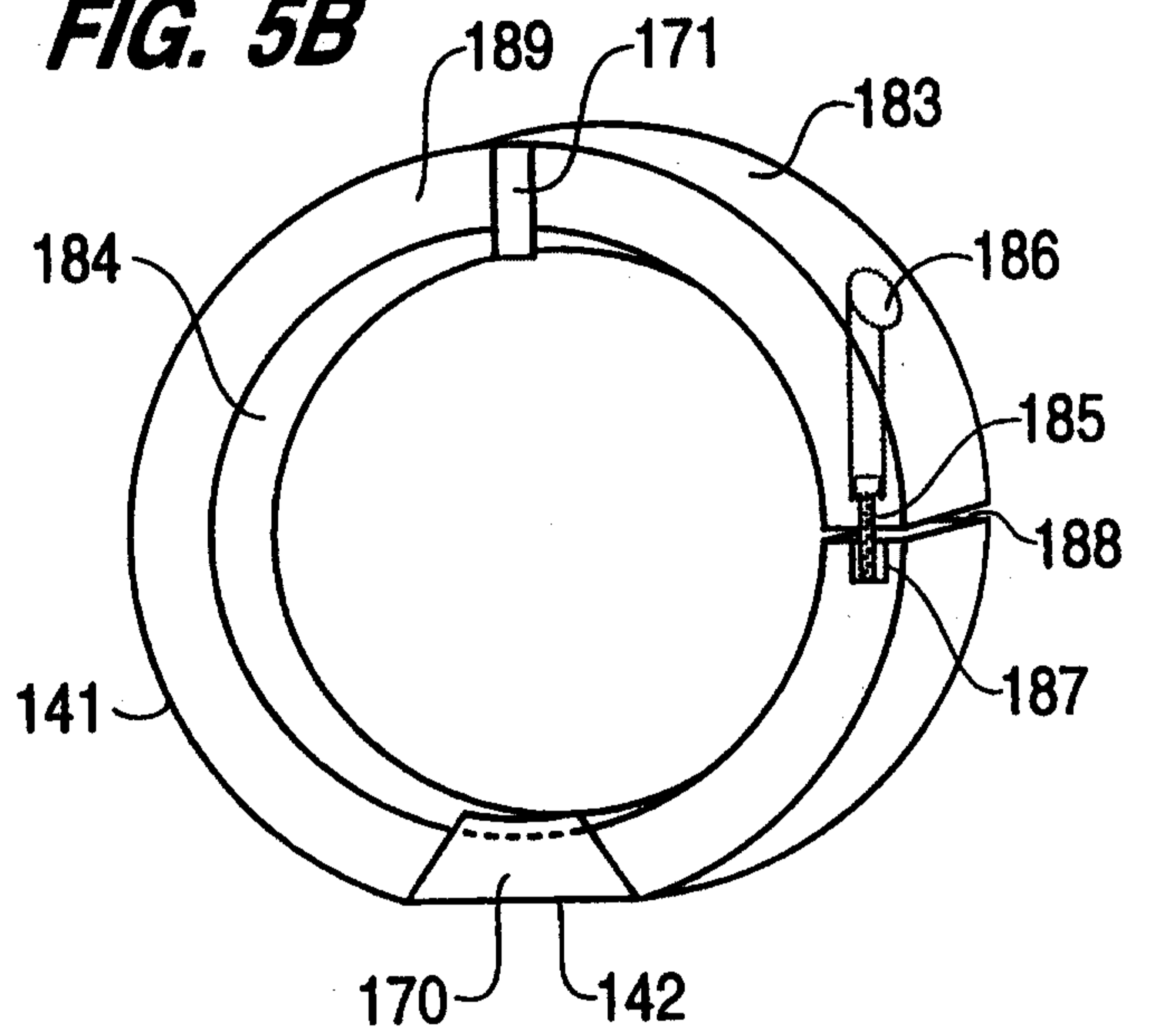

**FIG. 5C**

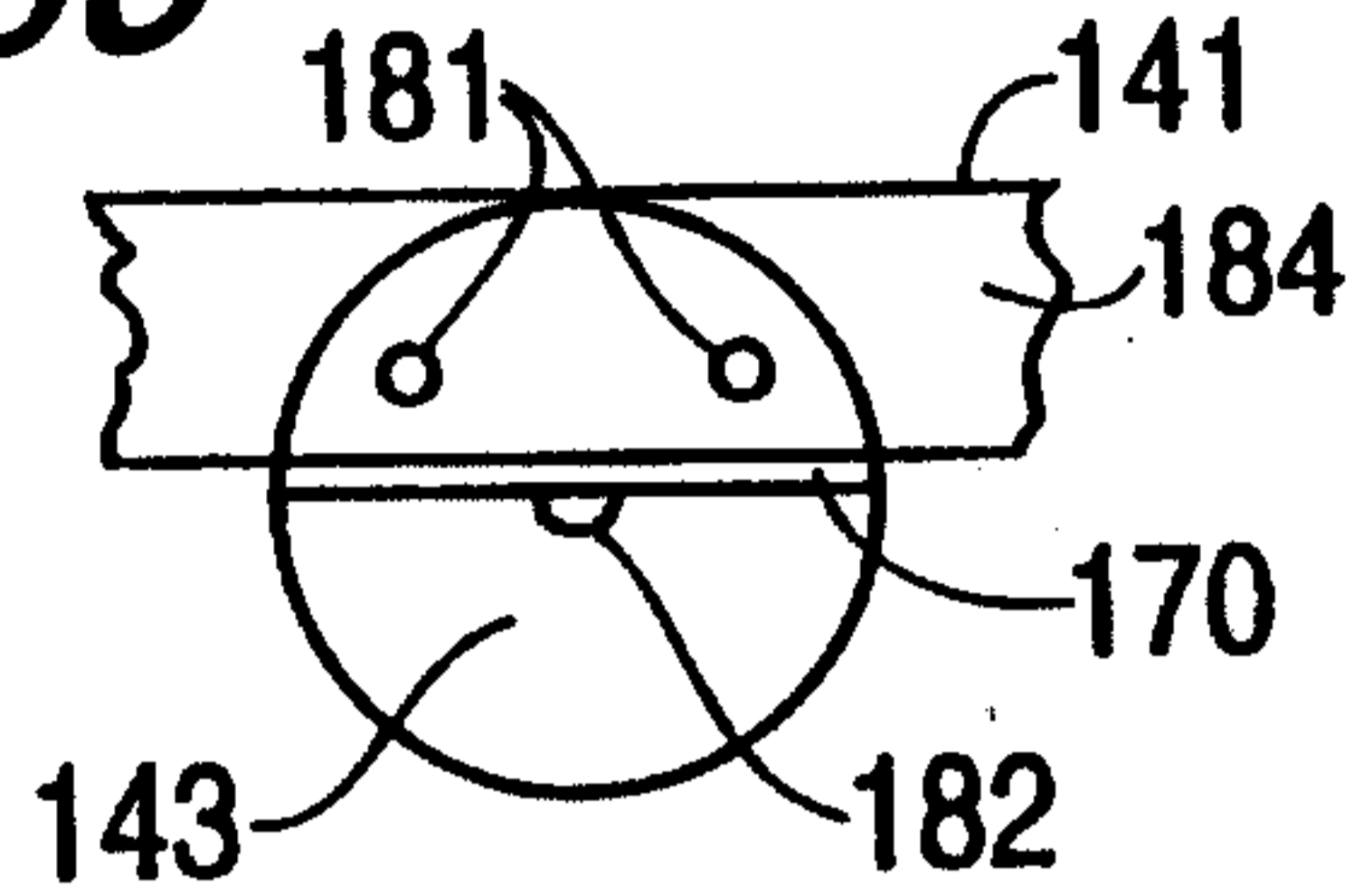

**FIG. 5E**

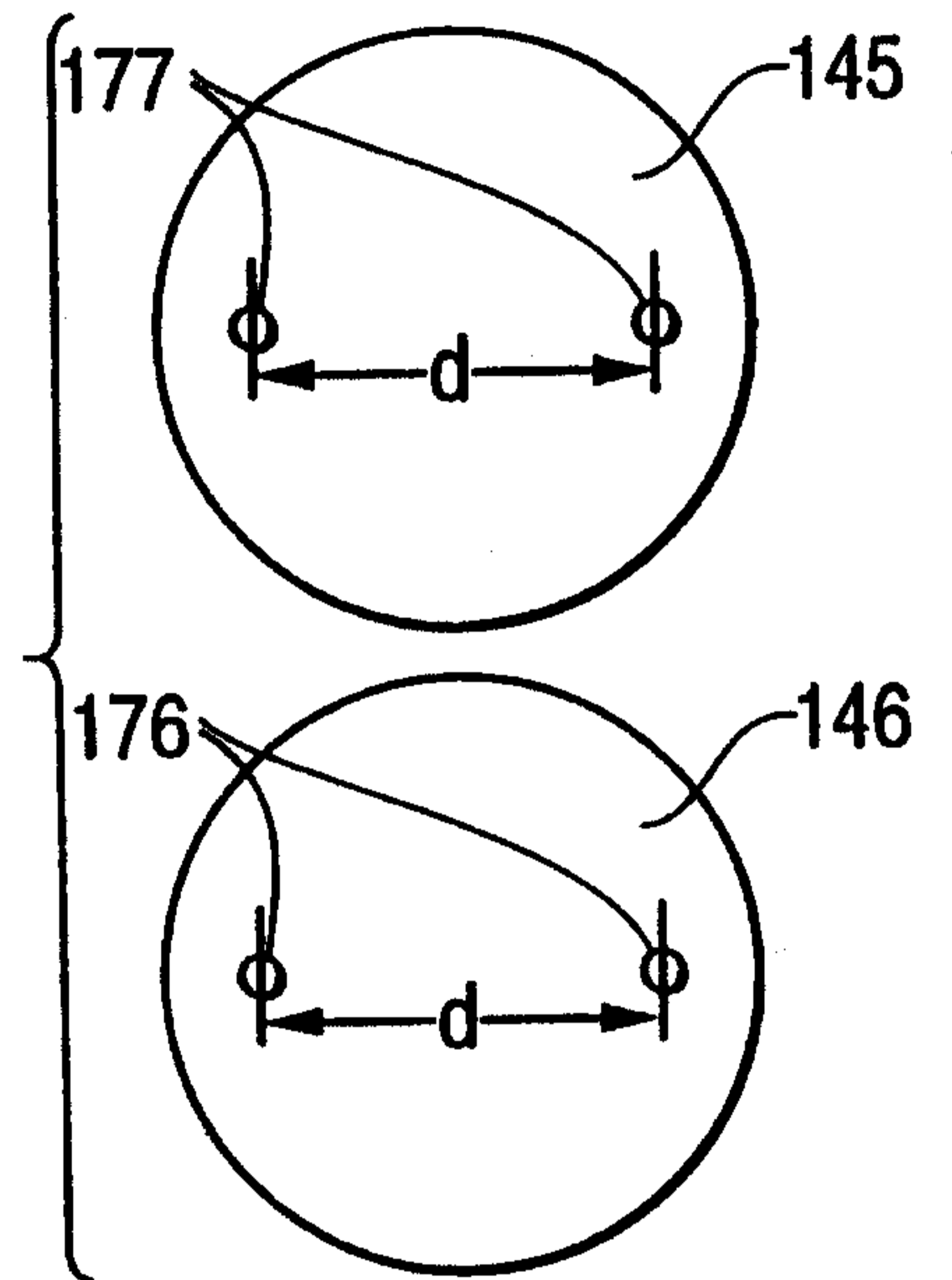

**FIG. 5D**

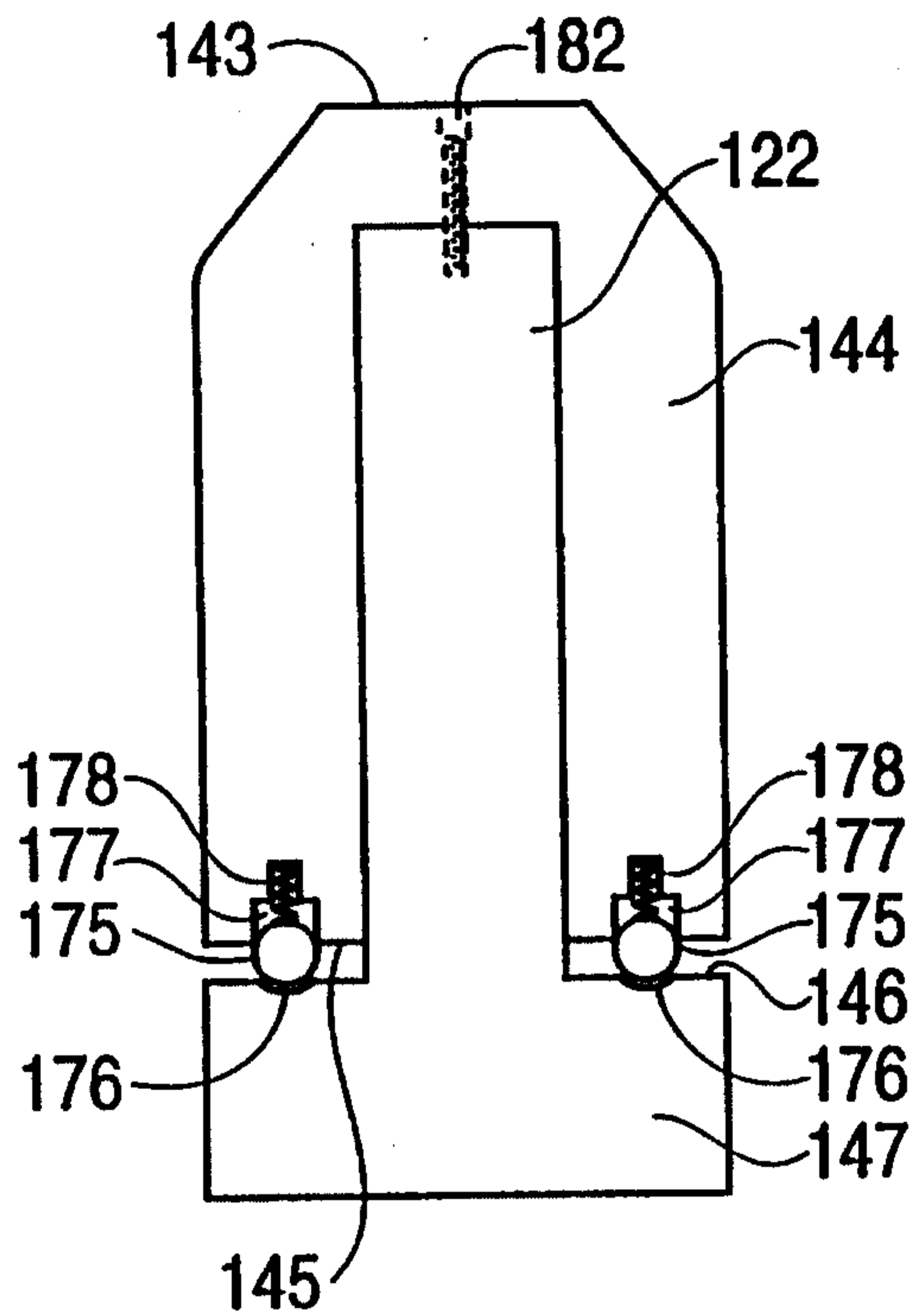

**FIG. 5F**

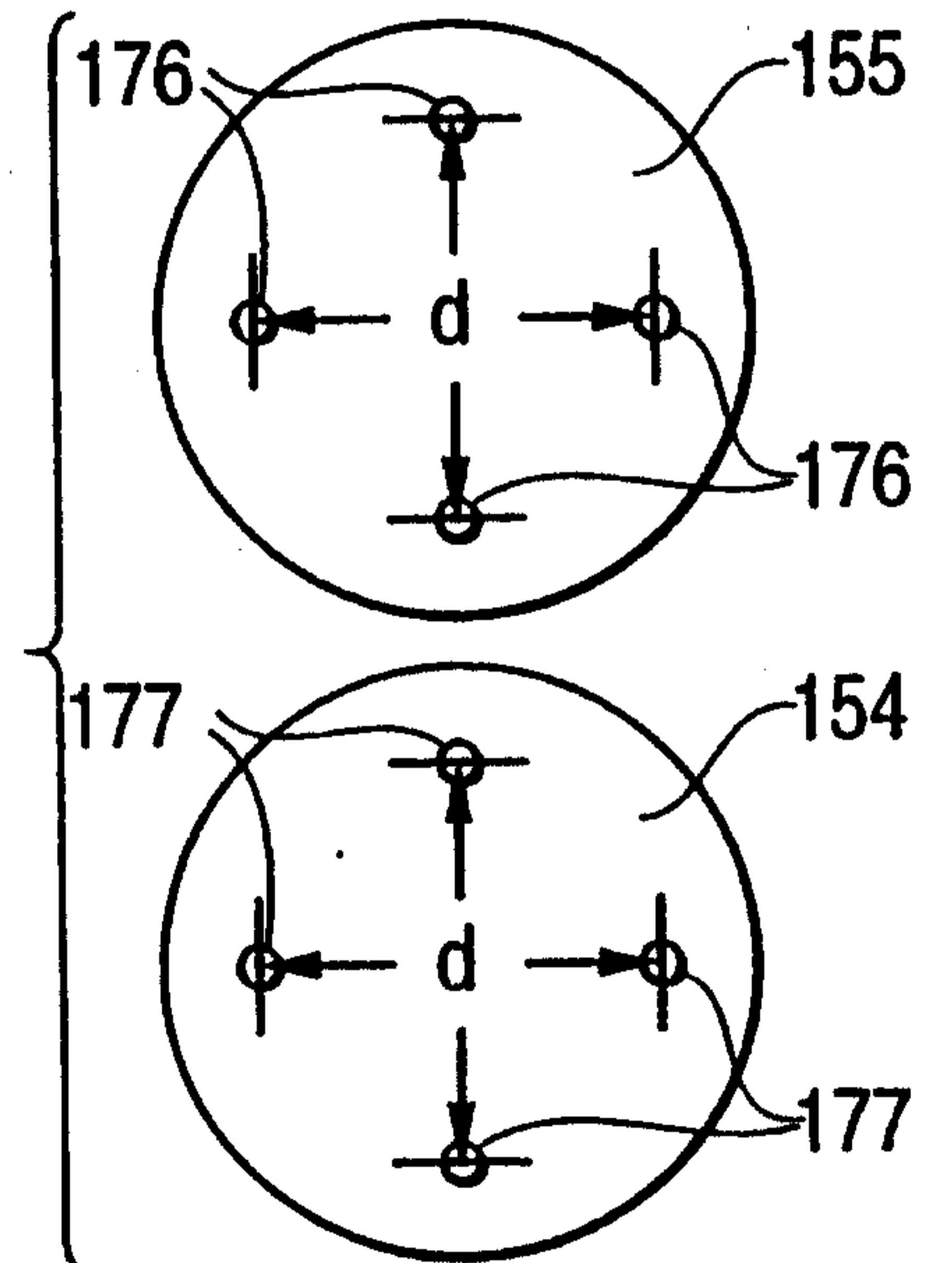

**FIG. 5G**

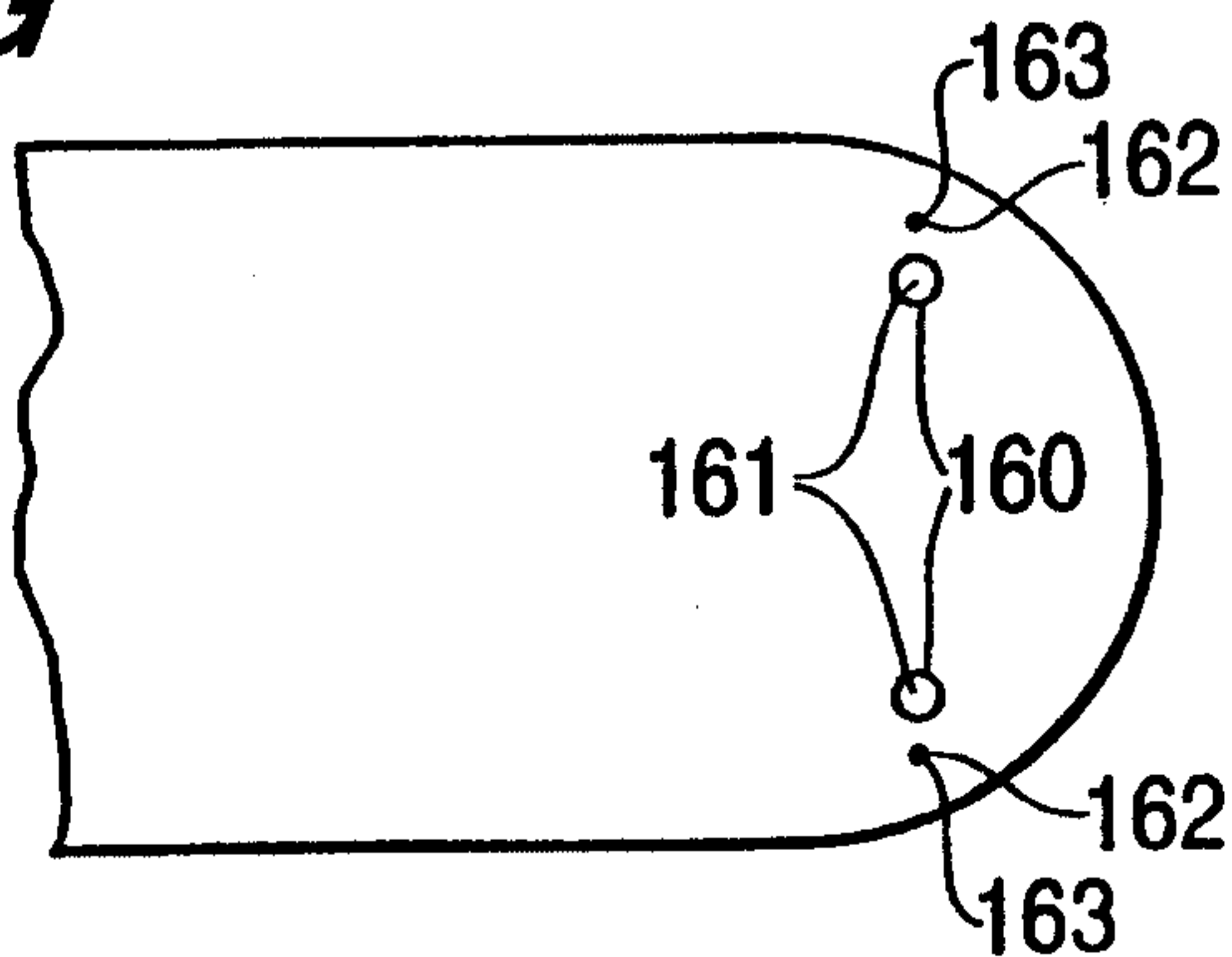

**FIG. 6**

