



US 20080032259A1

(19) **United States**

(12) **Patent Application Publication**
Schoeffel

(10) **Pub. No.: US 2008/0032259 A1**

(43) **Pub. Date: Feb. 7, 2008**

(54) **APPARATUS FOR EVACUATION OF ROOT CANAL**

Publication Classification

(76) Inventor: **G. John Schoeffel**, Dana Point, CA (US)

(51) **Int. Cl.**
A61C 5/02 (2006.01)
(52) **U.S. Cl.** **433/81; 433/91**

Correspondence Address:
DISCUS DENTAL IMPRESSIONS, INC.
8550 HIGUERA STREET
CULVER CITY, CA 90232 (US)

(57) **ABSTRACT**

(21) Appl. No.: **11/629,552**
(22) PCT Filed: **Jun. 14, 2005**
(86) PCT No.: **PCT/US05/21039**
§ 371(c)(1),
(2), (4) Date: **Dec. 13, 2006**

In an endodontic procedure, after the working of a root canal by instruments to remove material and shape the walls of the canal, irrigant is supplied via a microcannula. A vacuum is applied via a tube which is inserted partway down the root canal. The tube and microcannula pass through a material created by a standard dental filling material of a composite nature which provides a seal at a position near the top of the coronal opening. The irrigant is supplied in a manner sufficient to ensure delivery to a side vent of the microcannula. The vacuum at the end of tube draws the irrigant and debris up from the apex of the root canal into the tube. The side vent may have a plurality of more round holes, a diagonal slit, or a U shaped slit, or any other shape. The vent opening should not extend more than approximately 0.75 mm from the closed spherical tip of the microcannula, it must be burr free and the opening must be smaller than the internal diameter of the microcannula.

Related U.S. Application Data

(63) Continuation-in-part of application No. 11/152,942, filed on Jun. 13, 2005, now Pat. No. 7,226,288.
(60) Provisional application No. 60/579,915, filed on Jun. 14, 2004.

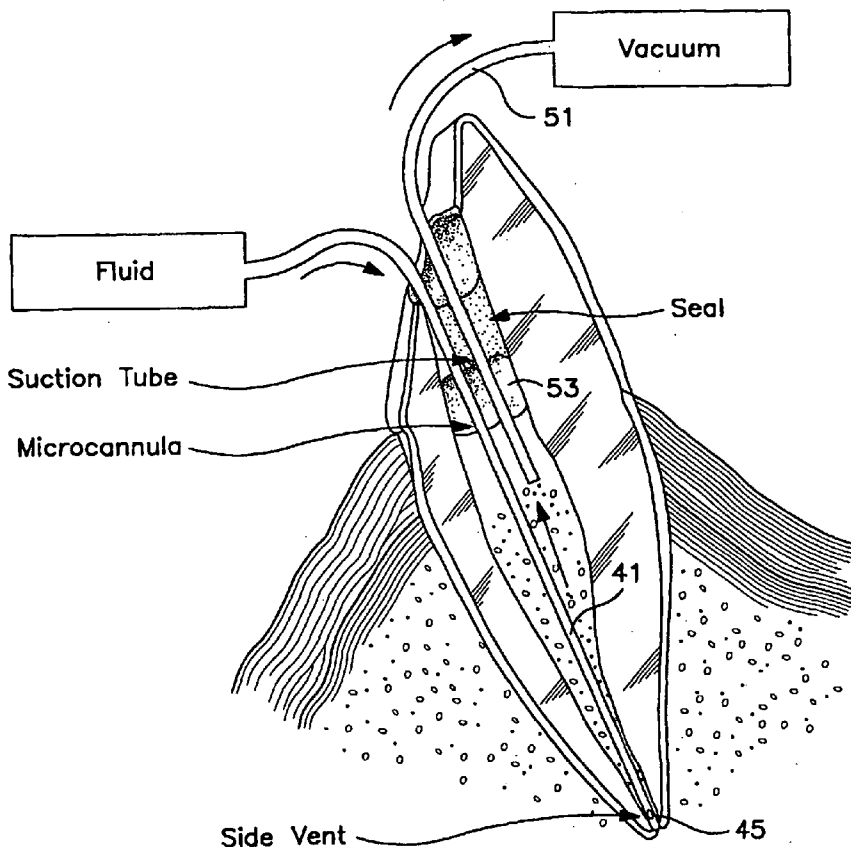

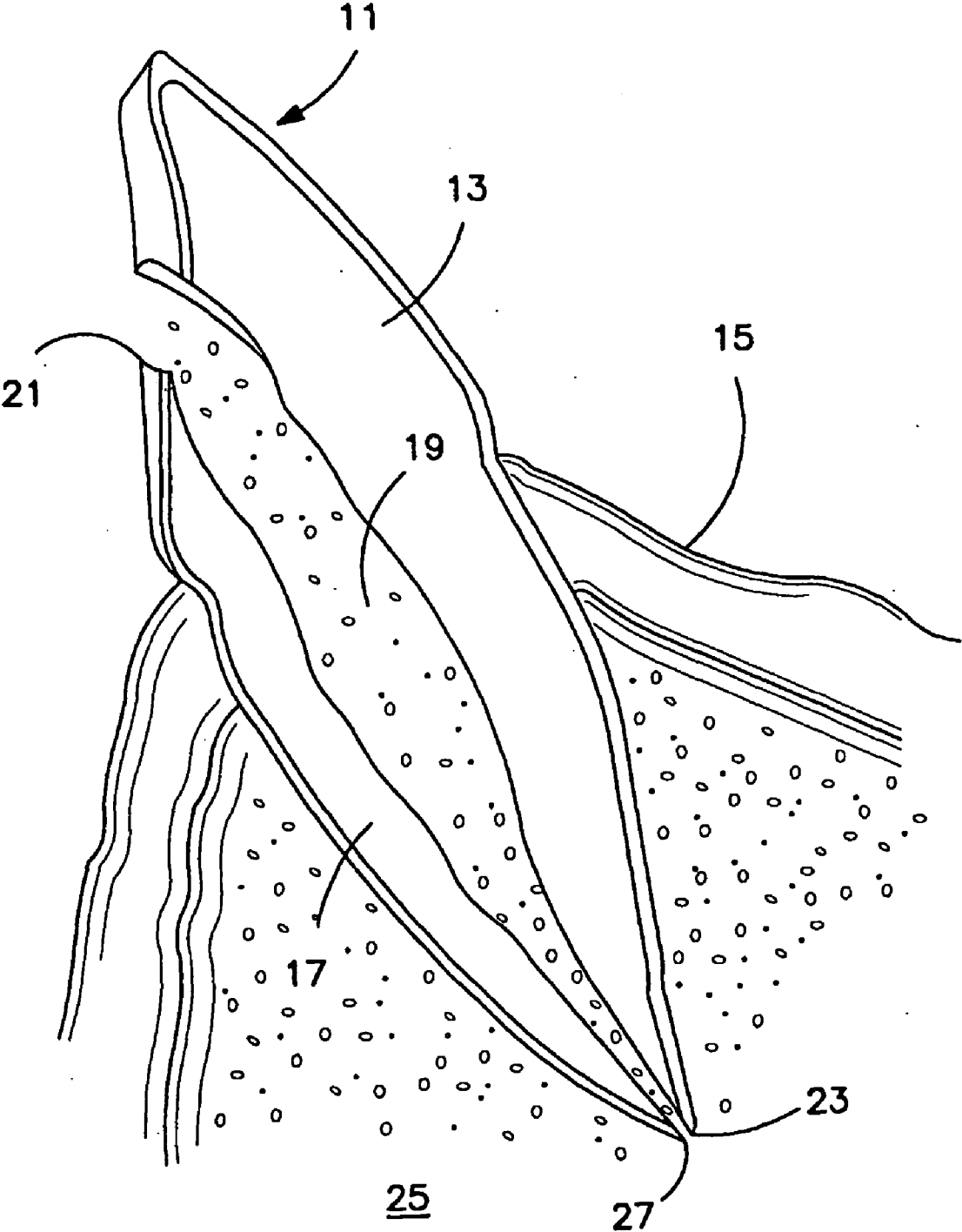

FIG. 1

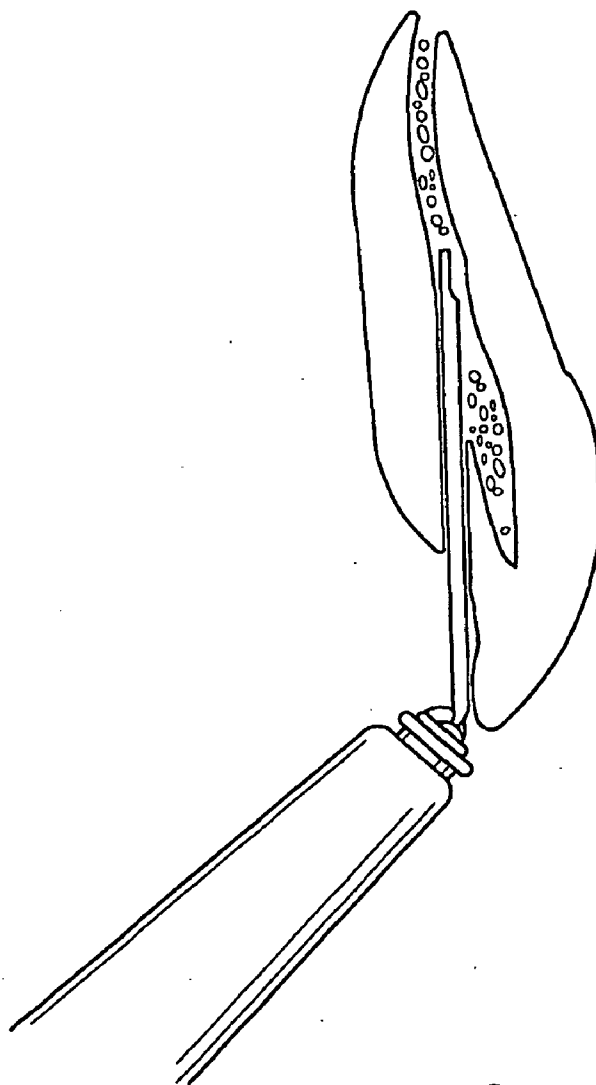

FIG. 2a

PRIOR ART

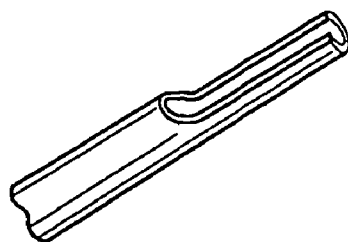
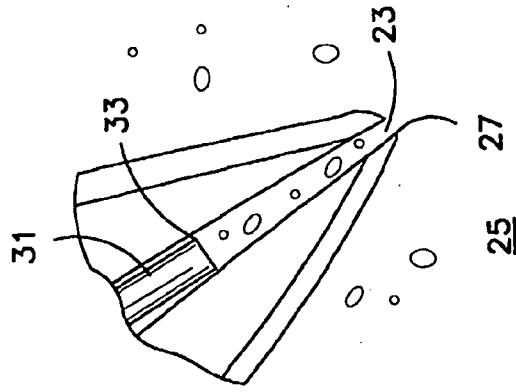
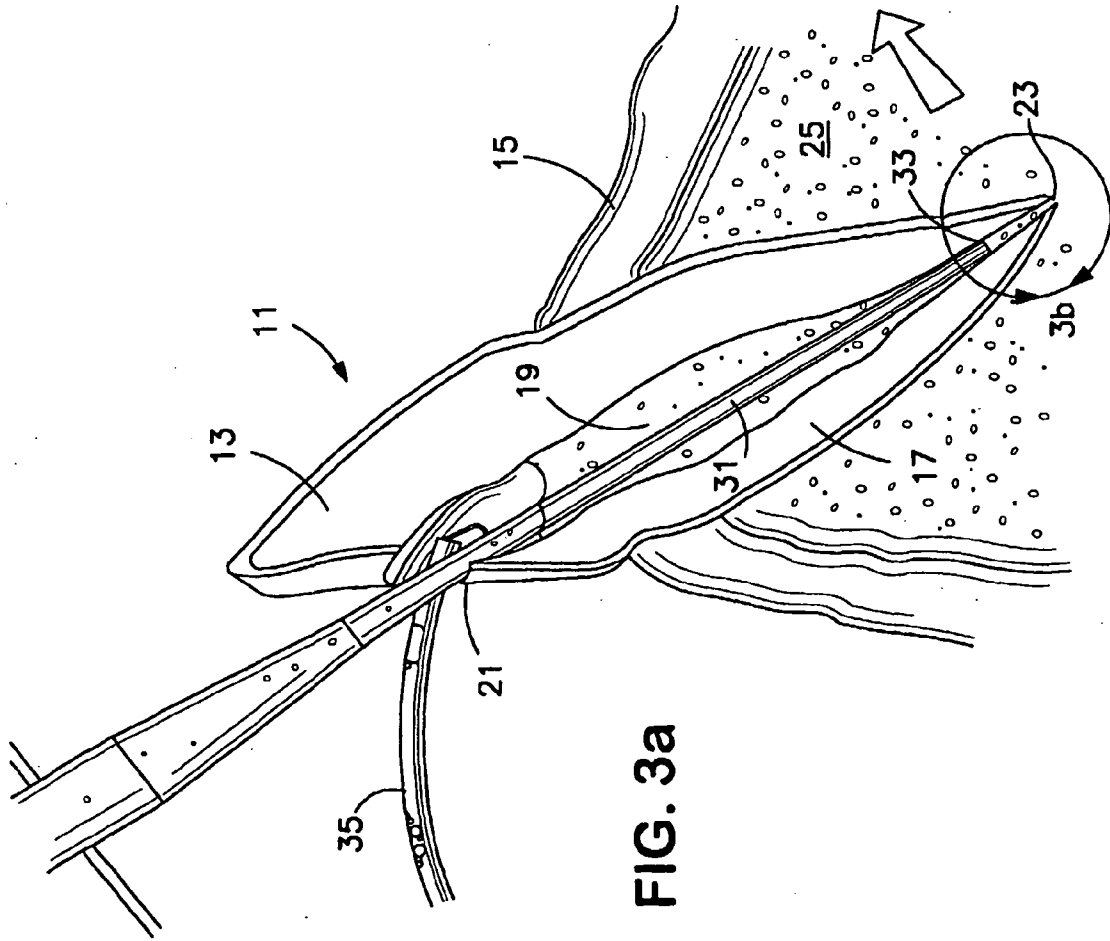

FIG. 2b

PRIOR ART



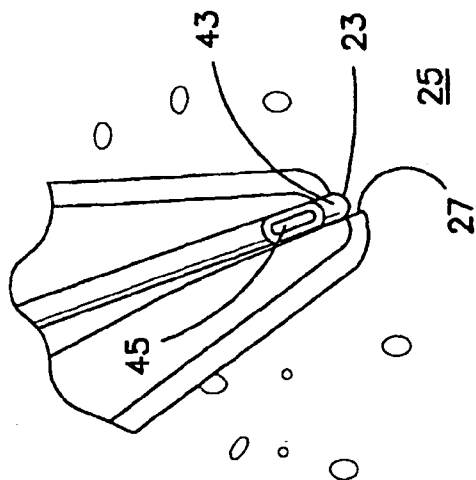

FIG. 4b

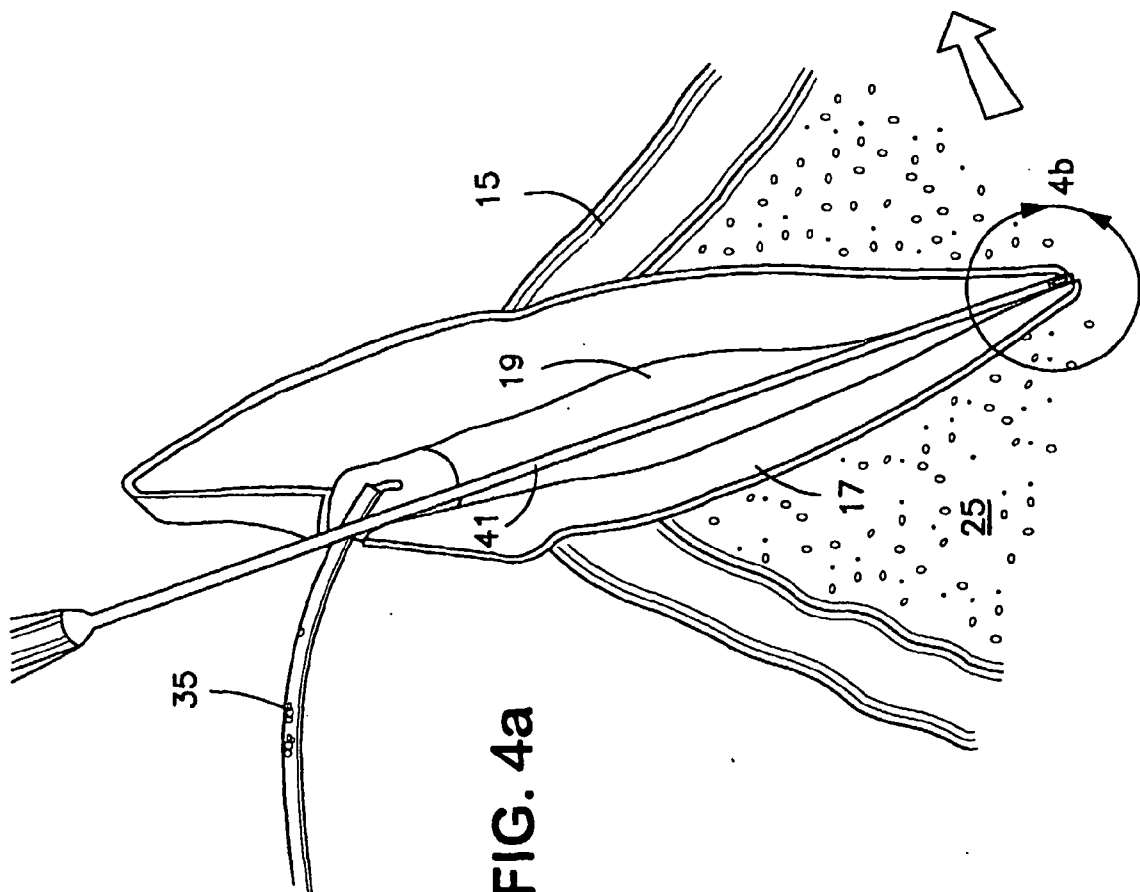

FIG. 4a

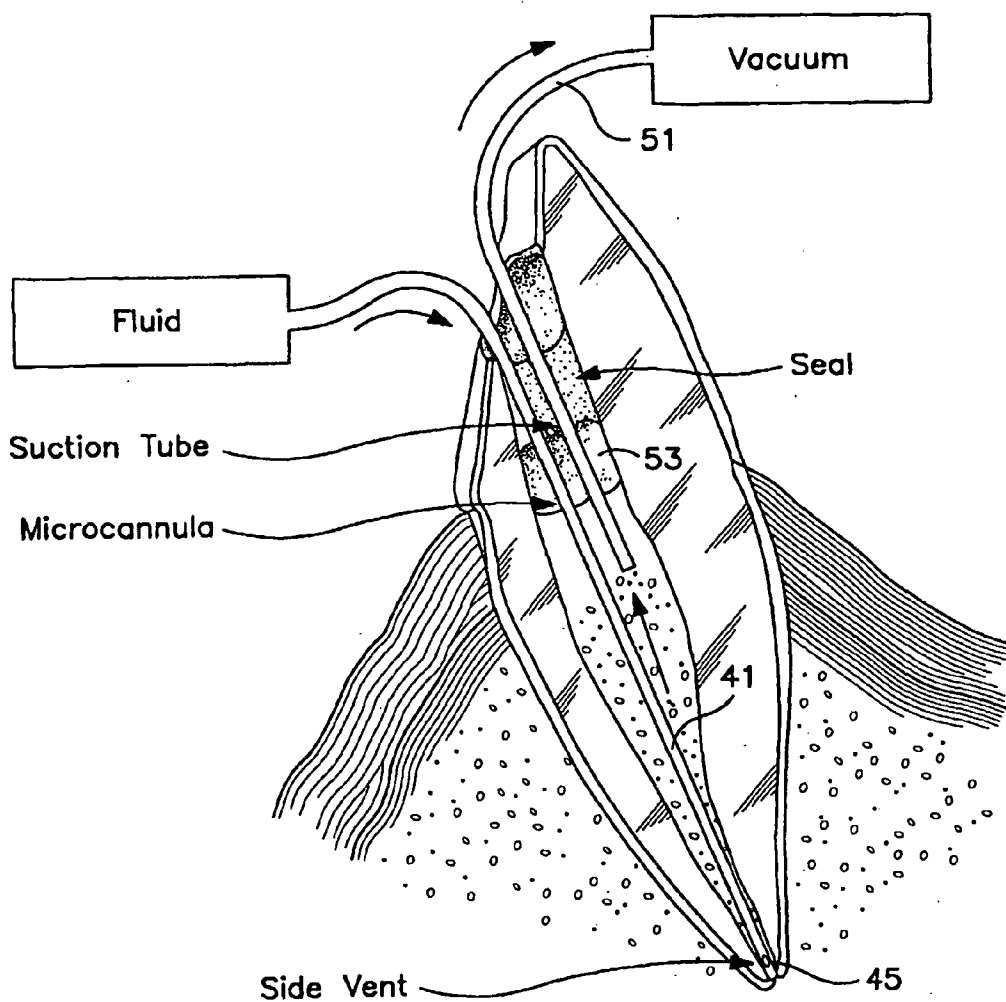

FIG. 5

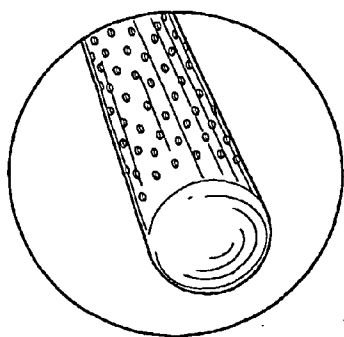

FIG. 6C

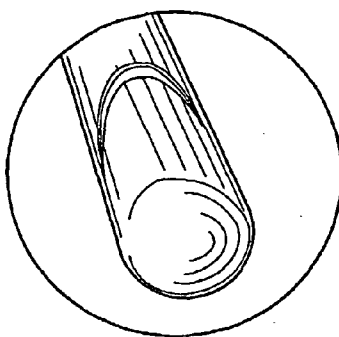

FIG. 6E

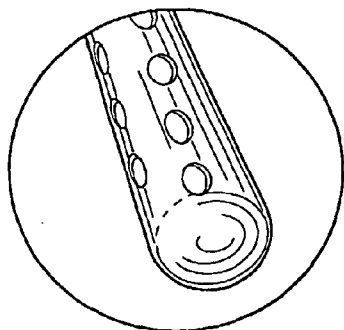

FIG. 6B

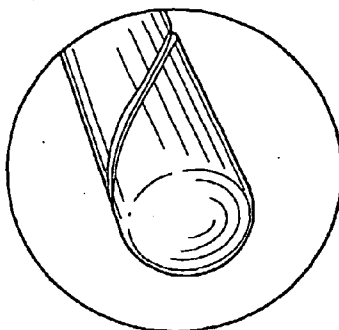

FIG. 6D

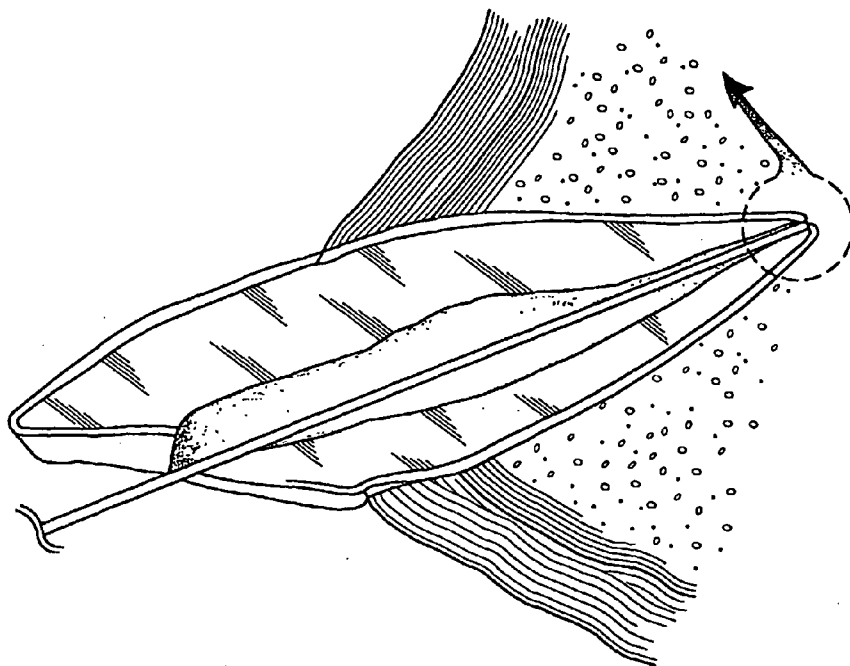

FIG. 6A

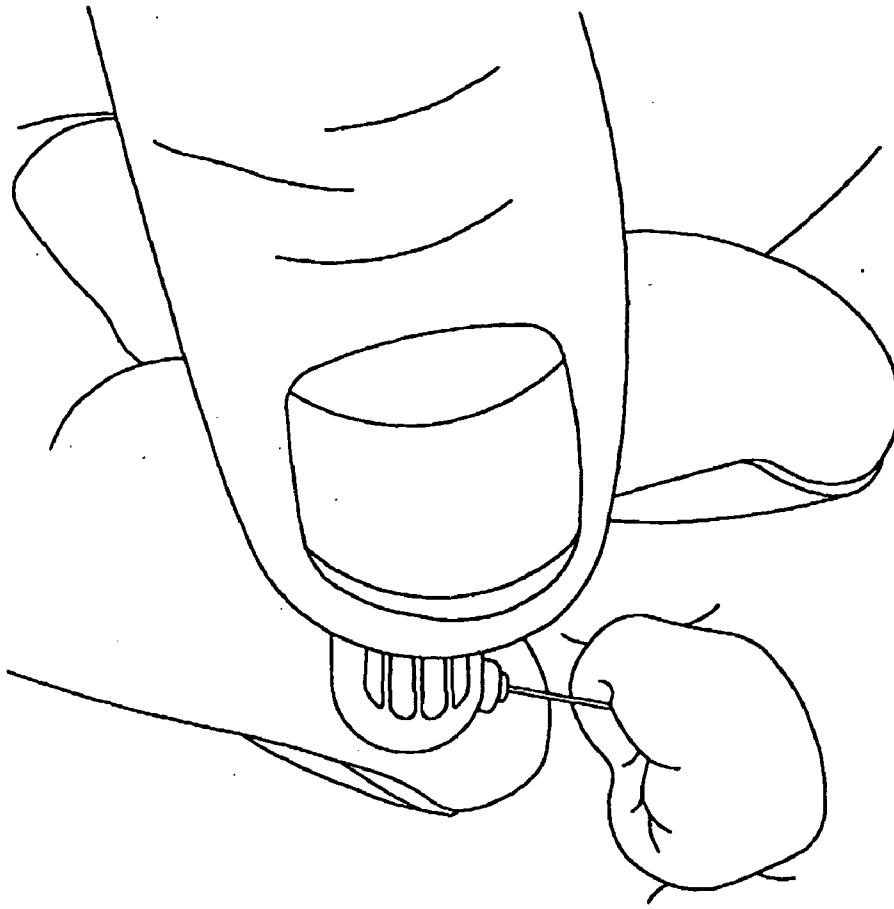

FIG. 8

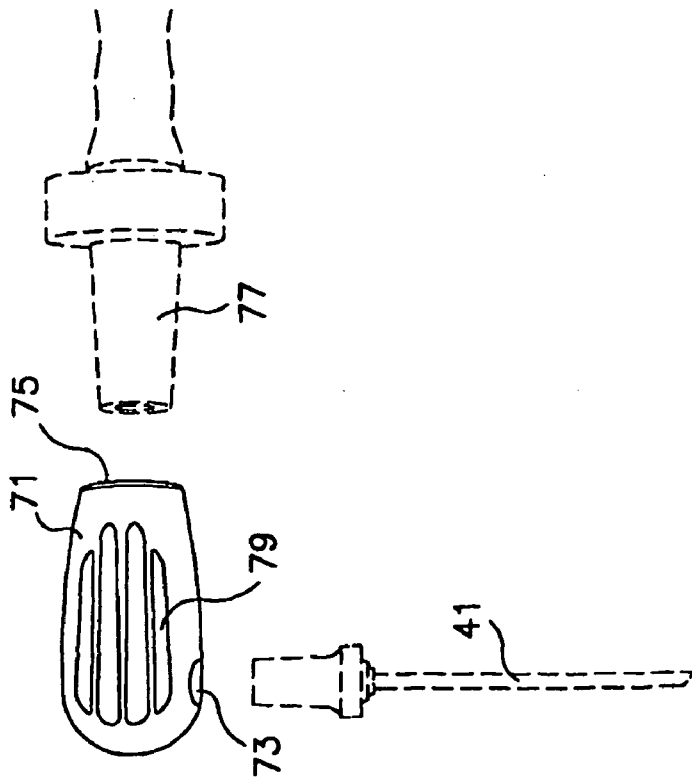

FIG. 7

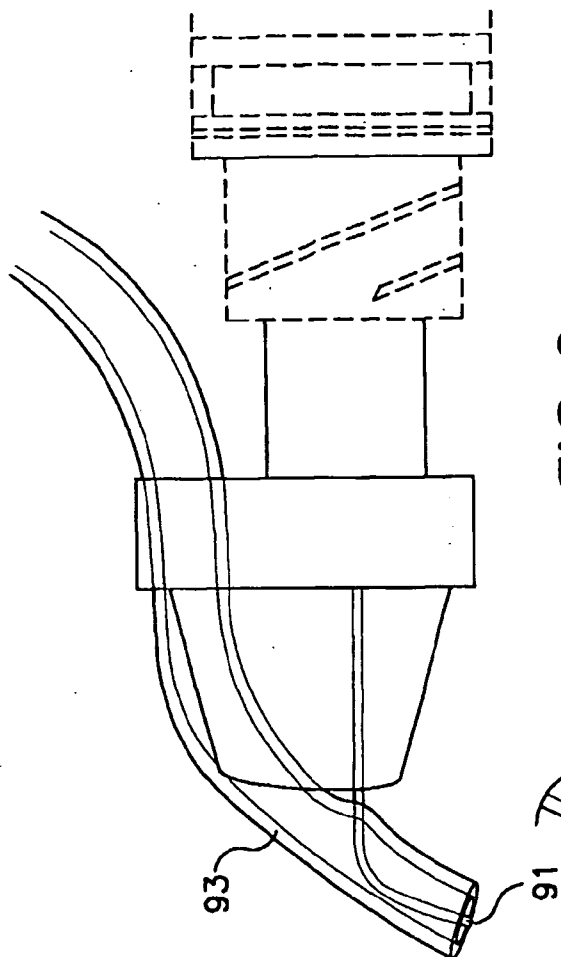

FIG. 9

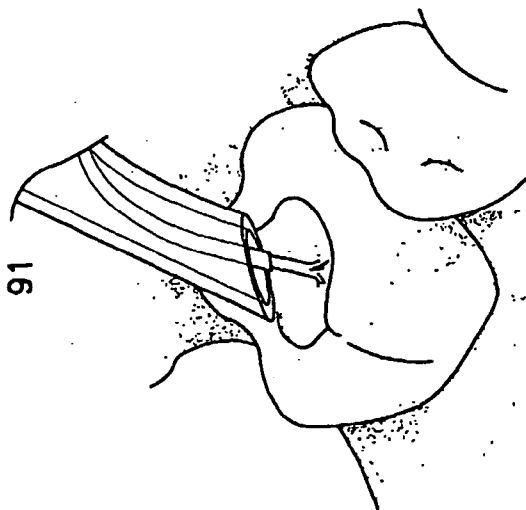

FIG. 10

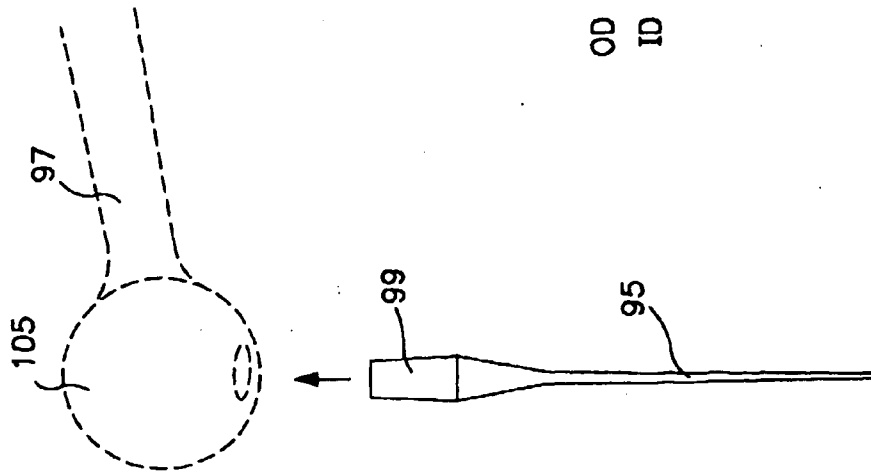

FIG. 11a

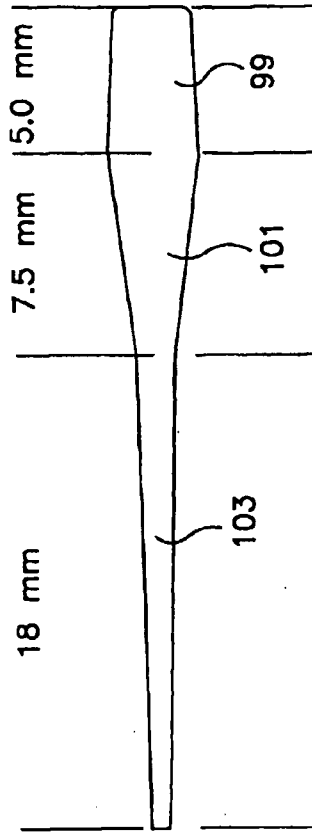

FIG. 11b

OD = .55 mm (.22")
ID = .36 mm (.014")

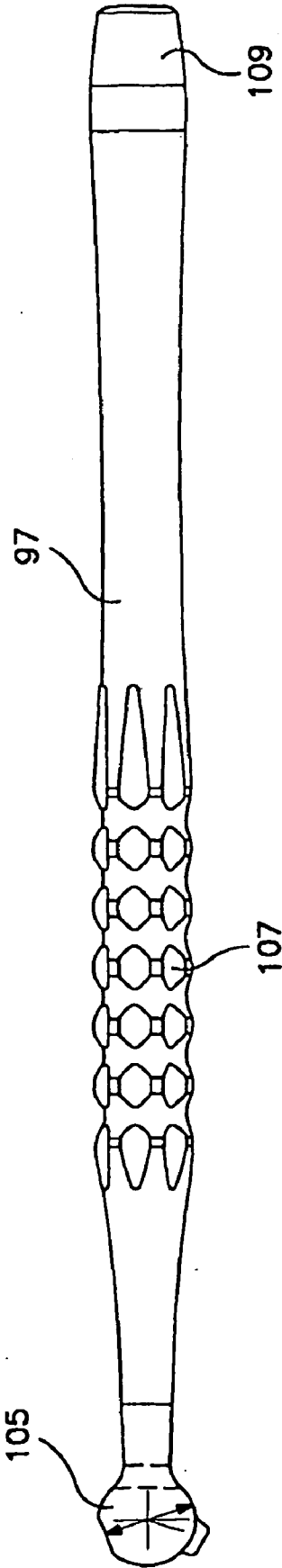

FIG. 12

APPARATUS FOR EVACUATION OF ROOT CANAL

[0001] The present application is a non-provisional application claiming the benefit of the priority of provisional application Ser. No. 60/579,915 filed Jun. 14, 2004 and is a continuation-in-part of application Ser. No. 10/387,804 filed Mar. 13, 2003.

1. FIELD OF THE INVENTION

[0002] The invention is in the field of endodontics, more particularly methods and apparatus used during root canal procedures.

2. BACKGROUND OF THE INVENTION

[0003] To preserve a tooth that has or could develop a diseased pulp cavity, it is necessary to prevent bacterial proliferation within the root or pulp canal of the tooth by enlarging the canal without excessively weakening the root's wall by using endodontic files, bores, reamers or other instrumentation in order to: 1) mechanically remove as much of the root canal contents as is possible and 2) allow the introduction of irrigants into the root canal space that dissolve and disinfect organic debris, thus minimizing the presence of bacteria, as well as clearing the walls of the root canal of calcific debris created during instrumentation. After completing steps 1 and 2, the root canal is typically filled or obturated with a material such as gutta-percha and a sealer to occlude the pulp cavity and thus seal the root canal. This procedure is referred to as root canal therapy. Irrigation assists in removing debris and necrotic material remaining after the endodontic files, bores, and reamers used during the removing and shaping steps of the procedure. Although, the irrigant preferably is capable of dissolving or disrupting soft tissue remnants to permit their removal, the irrigant may be any suitable liquid such as water or various alcohols. More particularly, although some degree of debridement is preferred, any fluid may be used to flush debris from the root canal. General examples of appropriate irrigants include hydrogen peroxide and sodium hypochlorite. In order to ensure that as much of the debris and necrotic material as possible is removed, the irrigant is typically applied under pressure using a syringe and a needle inserted into the canal as shown in FIG. 2. However, as reported in *Endodontics*, 5th Edition, by John I Ingle and Leif K Bakland published June 2002, pages 502-503, it is important that the needle fit loosely in the canal to allow backflow. It is also reported that there is little flushing beyond the depth of the needle unless the needle is bound in the canal and the irrigant forcibly ejected which is undesirable due to the danger of an irrigant such as sodium hypochlorite breaching the apex of the canal and entering the periapical tissue. However, unless the end of the needle is near the apex, the portion of the canal from the apex to the end of the needle cannot be effectively irrigated. But placing the end of the needle near the apex increases the likelihood of the irrigant, which is applied under pressure, entering the periapical tissue. This can be a source of post treatment endodontic pain for the patient. Furthermore, if a significant quantity of an irrigant like sodium hypochlorite is accidentally injected into the periapical tissue, morbid clinical complication can occur including excruciating pain, immediate swelling (ballooning) of the tissue and profuse bleeding.

[0004] Existing techniques attempt to address this problem by using very small needles to get close to the apex

while still fitting loosely in the canal to allow backflow or using an instrument to move some of the irrigant towards the apex with the irrigant no longer under pressure. However, neither technique completely solves the problem. Even the tip of the smallest needles that deliver irrigants under pressure must be kept a safe distance (approximately 4-6 mm) away from the apex in order to avoid accidentally forcing irrigants into the periapical tissue. This safety issue most often results in an area or zone between the apex and needle tip devoid of irrigant. Use of an instrument to force the irrigant through this zone towards the apex is very time consuming and also does not guarantee that the irrigant has flushed the canal all the way to the apex without going too far.

SUMMARY OF THE INVENTION

[0005] The present invention addresses the prior art problems of inadequate delivery of the irrigant to the apex of the canal resulting in an incomplete cleaning of the canal and penetration of the irrigant past the apex into the periapical tissue resulting in treatment complications. According to the invention, after the working of the canal by instruments to remove material and shape the walls of the canal, a cannula is inserted into the canal extending to about 5 mm from the apex and a vacuum is applied which begins to suck up the debris inside the canal. As this vacuum is applied, a small tube used to deliver irrigant is placed just inside the coronal opening of the root canal. Irrigant is passively flowed into the opening of the root canal, but not under pressure. As the irrigant is supplied, it is drawn to the source of the vacuum causing it to cascade down the walls of the root canals, into the tip of the cannula and out through the vacuum system. After several minutes of irrigant cascading down the canal walls, the cannula is removed and a second, smaller cannula with a hole in its wall near the tip is inserted into the canal until it virtually touches the apical tissue, but unlike the prior art, extending it past the apex does not cause irrigant to enter the periapical tissue because as soon as the hole enters the periapical tissue, since it is no longer in an open space, the vacuum created by the cannula is not present. In an alternate embodiment, instead of delivering irrigant via the cannula and applying a vacuum to the microcannula, the irrigant may be supplied via the microcannula. In this embodiment, a vacuum is applied via a tube which is inserted partway down the root canal. Tube and microcannula pass through a material created by a standard dental filling material of a composite nature which provides a seal at a position near the top of the coronal opening. The irrigant is supplied in a manner sufficient to ensure delivery to the side vent of the microcannula. The vacuum at the end of tube draws the irrigant and debris up from the apex of the root canal into the tube.

BRIEF DESCRIPTION OF THE DRAWINGS

[0006] FIG. 1 is a cut away side view of a tooth showing its root canal and periapical tissue.

[0007] FIG. 2 shows a prior art endodontic irrigation system.

[0008] FIG. 3a is a cut away side view of a tooth showing a first cannula and fluid delivery tube.

[0009] FIG. 3b is an expanded view taken along line 3b-3b of FIG. 3a.

[0010] FIG. 4a is a cut away side view of a tooth showing a second cannula and fluid delivery tube.

[0011] FIG. 4b is an expanded view taken along line 4b-4b of FIG. 4a

[0012] FIG. 5 is a cut away side view of a tooth showing an alternate embodiment of the invention illustrated in FIG. 4a.

[0013] FIGS. 6a-6e show alternates embodiments of the side vent used by microcannula 41.

[0014] FIG. 7 shows a finger piece for use with the invention.

[0015] FIG. 8 shows how the finger piece of FIG. 7 is used.

[0016] FIG. 9 shows a master delivery tip with syringe for use with the invention.

[0017] FIG. 10 shows how the master delivery tip of FIG. 9 is used.

[0018] FIGS. 11a and 11b show the detail of a macro cannula or cannula for use with the invention.

[0019] FIG. 12 shows a handle which may be used to hold the macro cannula shown in FIGS. 11a-11b.

DETAILED DESCRIPTION OF THE INVENTION

[0020] FIG. 1 illustrates a cutaway portion of a human tooth 11 as it may appear after a portion of a root canal procedure has been completed, namely wherein as much of the pulp material as is possible has been removed by instrumentation. The tooth 11 includes a crown portion 13 which is generally the exterior portion extending past gums 15. The interior portion of the tooth extending past the other side of gums 15 is referred to as the root 17. In approximately the middle of the root extending almost the entire length of the root is the root canal 19 which extends from one end 21 near the crown portion of the tooth to an apex 23 at the tip of root 17. As shown in FIG. 1, the non-visible portion of tooth 11 extending past gums 15 is surrounded by periapical tissue 25.

[0021] Of course, prior to the initiation of the root canal procedure, the apical foramen 27 located at or very near the root apex 23 is the only opening into the root canal.

[0022] After the instrumentation phase of the root canal procedure has been completed, there is a large quantity, both in terms of size and amount, of debris within the root canal.

[0023] According to the present invention, after the instrumentation step, cleansing of the root canal is performed in two phases. The first phase is referred to as gross evacuation of the coronal portion of the root canal which is the portion of the root canal 19 beginning approximately 4-5 mm from apex 23. The second phase is referred to as apical evacuation for cleaning the final 4-5 mm of the root canal.

[0024] Referring now to FIG. 3a, the methods and apparatus used for the gross evacuation of the coronal portion of the root canal will now be explained. A cannula 31 is inserted into the canal to a point 33 approximately 4-5 mm from the apex as seen in FIG. 3b. A suitable cannula for this purpose is a soft plastic cannula such as part number UP0341 available from Ultradent Products, Incorporated located in South Jordan, Utah. Of course, any comparable device may be used for this purpose. A vacuum is applied to

the cannula as is well known in the art which results in debris being sucked up into the cannula. Specifics of a suitable delivery tube 35 and vacuum system are well known to persons skilled in the art.

[0025] A fluid delivery tube 35 is placed at the top of the coronal opening of the root canal at end 21 as shown in FIG. 3a and the desired irrigant is supplied by fluid delivery tube 35. A suction exists at point 33 of the cannula by virtue of an opening in the end of the tube adjacent to point 33 and the applied vacuum which results in the irrigant and remaining debris being drawn to the hole in the end of cannula at point 33. This irrigation and suction results in a nearly complete cleaning of the upper portion of the canal, i.e., the portion extending from the tip of the cannula at point 33 through the entire length of the canal to end 21. This occurs because as the irrigant is delivered via the delivery tube, the irrigant fills the root canal space combines with the debris and together are sucked down the root canal by virtue of the vacuum created at the end of delivery tube at point 33 and then up through cannula 31 by virtue of the vacuum created. This step normally takes several minutes to complete depending on the size of the root canal space. For example upper canine teeth have larger root canal spaces than lower incisors and require a longer initial irrigation. At the end of this phase the irrigant will be clear and devoid of gas bubbles formed by the dissolving necrotic tissue as well as particulate matter remaining from instrumentation.

[0026] It should be noted that although some irrigant may go past end 33, the 4-5 mm distance from apex 23 is sufficient to prevent any irrigant from reaching periapical tissue 25.

[0027] The gross evacuation of the canal debris in the upper portion of the root canal is critical to the proper completion of phase two since a much smaller tube is used to evacuate the apical portion, i.e., the bottom 4-5 mm of the root canal. This is because the debris in the upper portion of the root canal, prior to the evacuation performed by phase one, includes particles of a size which would clog the smaller opening of the microcannula which is inserted into the apical portion of the root canal.

[0028] Phase two of the procedure will now be described with references to FIGS. 4a and 4b. In phase two, a microcannula 41 is inserted into the root canal extending to the apex 23 as best seen in FIG. 4b. Microcannula 41 is typically made of a metallic material such as stainless steel or titanium and in one embodiment, has an outside diameter of 0.014 inches. Its tip 43 is welded shut and rounded and includes a side vent approximately 0.75 mm long beginning at a point approximately 0.5 mm from the end of tip 43.

[0029] Of course, the foregoing dimensions and materials are provided by way of example of a specific embodiment. What is important is that microcannula 41 be sized so as to be able to fit into the canal so that it extends substantially completely to apex 23 with side vent 45 extending as close to the end of the root as possible but without extending into the periapical tissue. Further, microcannula 41 should be sized so that there is close contact between the root canal wall in the apical portion and the microcannula. This is to ensure that some of the irrigant is drawn to the end of microcannula 41 by capillary action.

[0030] As was the case in phase one, irrigant is delivered via delivery tube 35 and a vacuum is applied to microcannula 41. In this manner, irrigant is drawn down into the root canal and into the apical portion of the root canal, that is, the

bottom approximately 4-5 mm portion of the canal ending at apex **43**. Since tip **43** is closed, irrigant is drawn into vent **45** and does not extend past tip **43** and cannot be drawn into apical tissue **25** due to the vacuum which exists at vent **45**. By this technique, the irrigant flushes the apical portion of the root canal, removing out any remnants of debris which still exist in a manner which does not allow the irrigant to enter the periapical tissue.

[0031] Additionally, and importantly, in the event microcannula **41** is accidentally forced into the periapical tissue, the side vent will become obstructed by the tissue and the vacuum which exists in the root canal ceases to exist. Since the irrigant in the canal is not under pressure, the irrigant will cease to be withdrawn by microcannula **41** indicating to the practitioner that the microcannula has extended too far and needs to be withdrawn back into the root canal space slightly, up to the point when the side vent is not in the periapical tissue at which point the irrigant again begins to be withdrawn.

[0032] In an alternate embodiment, and referring now the FIG. 5, instead of delivering irrigant via delivery tube **35** and applying a vacuum to microcannula **41**, the irrigant may be supplied via the microcannula. In this embodiment, a vacuum is applied via a tube **51** which is inserted partway down the root canal. Tube **51** and microcannula **41** pass through a material created by a standard dental filling material of a composite nature (like the material used in white dental fillings) or alternately a standard dental impression material usually made of a silicone nature which provides a seal at a position near the top of the coronal opening. The irrigant is supplied in a manner sufficient to ensure delivery to the side vent **45** of the microcannula. The vacuum at the end of tube **51** draws the irrigant and debris up from the apex of the root canal into the tube.

[0033] In this alternate embodiment, the flow of the irrigant may be reversed from apex to crown by placing the microcannula adjacent to the apex, installing a vacuum tube into the canal near the coronal portion and sealing the canal coronally such that both the microcannula and vacuum tube are below the seal, with the vacuum tube being positioned more coronally. As a vacuum is applied to the coronal tube, irrigant is allowed to be drawn into the canal via the microcannula, then up the walls into the vacuum tube.

[0034] Referring now to FIGS. 6a-6e, side vent **45** instead of having a generally oblong shape as shown in FIG. 4b, may have a plurality of more round holes as shown in FIGS. 6b and 6c, a diagonal slit as shown in FIG. 6d or a U shaped slit as shown in FIG. 6e, or any other shape. In the FIG. 6b embodiment, the holes actually extend around the circumference of the microcannula. The diameter of the microcannula is 0.318 mm and the distance between the tip of the microcannula and the bottom of the hole nearest the tip is 0.22 mm. In one embodiment, the opening should not extend more than approximately 0.75 mm from the closed spherical tip of the microcannula, must be burr free and the opening must be smaller than the internal diameter of the microcannula to block any particles which clog the microcannula. The reasons the openings must be burr free is that the space where the microcannula is inserted is extremely restricted, and any burr extending from the opening is likely to scrape the dentin from the wall of the root canal and the resulting

debris could clog the side vent opening(s). Usually, microcannula **41** is coupled directly to a tube used to provide the vacuum or supply the fluid.

[0035] FIG. 7 shows a finger grip handle **71** used to hold microcannula **41** (shown in shadow line). The finger grip handle has an opening **73** into which microcannula **41** is inserted. A second opening **75** arranged 90° from opening **73** receives a tube (shown in shadow line) which is connected to a device which produces the required vacuum or supplies the required fluid. Ridges **79** provide a grip to assist holding the handle between two fingers as shown in FIG. 8. Given the relatively small dimensions of microcannula **41** and the difficulty of maneuvering the microcannula within the confines of the mouth to perform the desired procedure, finger grip handle **71** provides extra leverage not available without the handle. In a preferred embodiment, finger grip handle is made of titanium. The two openings are sized to so that the microcannula and vacuum or fluid delivery device are held by friction.

[0036] FIG. 9 shows a master delivery tip. The delivery tip includes a metal tube **91** set into a molded fixture made of non-reactive plastic like nylon or polypropylene that is inserted on a standard luer lock fitting. The molded fixture holds a flexible plastic tube **93** non-reactive plastic like PVC over the metal tube, the other end being attached to a vacuum pump (not shown). During clinical use the clinician is able to add a fluid into the access cavity preparation of a root canal. When the level of the fluid being applied tube **91** reaches the top of the access cavity preparation, the excess is sucked away by a vacuum applied to tube **93** rather than spilling into the oral cavity (mouth). This feature allows the dentist or dental assistant to maintain a constant level of fluid in the root canal access cavity and is helpful throughout all aspects of root canal preparation including instrumentation and irrigation. FIG. 10 shows this operation wherein the fluid being applied is concurrently sucked away.

[0037] FIG. 11a shows a specific design of a cannula **95** which may be used as cannula **31**. A top portion **99** which is 5.0 mm in length has a slight taper for fitting into an opening in a handle **97** shown in shadow line in FIG. 11a and in more detail in FIG. 11b. A middle portion **101** which is 7.5 mm in length tapers to an outside dimension of 1 mm. A third portion **103** tapers from 1 mm to 0.55 mm at its end. The inside dimension at this end is 0.36 mm. While it is preferable that there be no flash at the end of the third portion, there is a 5% of inside diameter surface area maximum flash permitted at this point, since anything larger would serve to trap canal debris.

[0038] FIG. 12 shows handle **97** having head **105** sized to fit the top end of cannula **95** (or microcannula cannula **41** or **31**) by friction. Raised elements **107** provide a finger grip. The opposite end **109** of handle **106** is sized to accept a tube from a vacuum unit (not shown).

1-11. (canceled)

12. An apparatus for irrigating a root canal of a tooth having a coronal end with an access cavity and an apex end, comprising:

at least one body portion; and

at least two tubes extending from said body portion, one of said tubes comprising a fluid delivery tube for

delivering a fluid into the canal, and the other of said tubes comprising a vacuum tube for connecting to a device for evacuation;

wherein at least a portion of the apparatus is adapted to be inserted into the canal access cavity.

13. The apparatus of claim 12 wherein each tube comprises an interior bore, and said bores of said fluid delivery tube and said vacuum tube do not communicate with each other independently of the canal.

14. The apparatus of claim 12 wherein said vacuum tube is adapted for positioning over the canal.

15. The apparatus of any of claim 12 wherein said vacuum tube is adapted to be disposed partway inside the canal for performing an evacuation of a coronal portion of the root canal.

16. The apparatus of claims 12 wherein said vacuum tube is adapted to be fully extended into the canal for performing an evacuation including the apex portion of the root canal.

17. The apparatus of claim 12 wherein said apparatus is adapted for performing an evacuation of a coronal portion of the root canal and followed by performing an evacuation of the apex portion of the root canal

18. The apparatus claim 12 wherein said vacuum tube comprises a microcannula.

19. The apparatus of claim 12 wherein both tubes are adapted to be positioned towards the coronal portion of the canal.

20. The apparatus of claim 12 wherein said at least two tubes comprises a second vacuum tube surrounding at least a portion of said fluid delivery tube.

21. The apparatus of claim 20 wherein both vacuum tubes are adapted to be connecting to the same device for evacuation.

22. The apparatus of claim 12 wherein said fluid delivery tube comprises a polymeric or a metal tube.

23. The apparatus of claim 12 wherein said body portion and said vacuum tube comprise a polymeric material or a metal.

24. The apparatus of claim 20 wherein said second vacuum tube comprises a polymeric material.

25. The apparatus of claim 19 wherein said microcannula comprises an uncovered end that is substantially closed.

26. An apparatus for use in irrigating a root canal comprising:

a cannula;

a microcannula; and

a handle adapted for coupling interchangeably to each of said microcannula and cannula used during a root canal procedure, said handle having a first opening at one end sized to hold each of said microcannula and said cannula by friction and a second opening at a second end arranged approximately 90° from said first opening and sized to hold a fluid delivery tube.

27. The apparatus of claim 26 further comprising a vacuum tube surrounding at least a portion of said fluid delivery tube.

28. The apparatus of claim 26 wherein said microcannula comprises a tube open at one end and closed at a second end, and adapted to be fitted into and extending substantially to the apex of the root canal.

29. The apparatus of claim 26 wherein said microcannula comprises a side vent disposed adjacent the second end, wherein said side vent comprises a plurality of holes, a generally diagonal slit or a U shaped slit.

30. The apparatus of claim 29 wherein said side vent is approximately 0.75 mm in length and begins approximately 0.22 mm from said second end.

31. The apparatus of claim 27 wherein said cannula or microcannula and said vacuum tube are adapted for connecting to the same device for evacuation.

32. A master delivery tip for delivering a fluid into a root canal having an access cavity, comprising:

a body portion; and

at least two tubes extending from the body portion, one of said tubes comprises a fluid delivery tube and the other of said tubes comprises a vacuum tube having one end adapted for coupling to an apparatus for evacuation;

wherein said fluid delivery tube is adapted for delivering a fluid into the access cavity of the root canal, and the vacuum tube is adapted for suctioning away any fluid above a certain level of the access cavity.

33. The master delivery tip of claim 32 wherein said vacuum tube has a second end disposed about and surrounding at least a portion of said fluid delivery tube.

34. The master delivery tip of claim 32 wherein each tube comprises an interior bore, and said bores of said fluid delivery tube and said vacuum tube do not communicate with each other independently of the canal.

35. The master delivery tip of claim 32 wherein said vacuum tube is adapted for positioning over the access cavity of the coronal end of the root canal.

* * * * *