

No. 830,643.

PATENTED SEPT. 11, 1906.

E. DARGATZ.
PADDED SAFETY PLATE FOR HORSESHOES.
APPLICATION FILED FEB. 5, 1906.

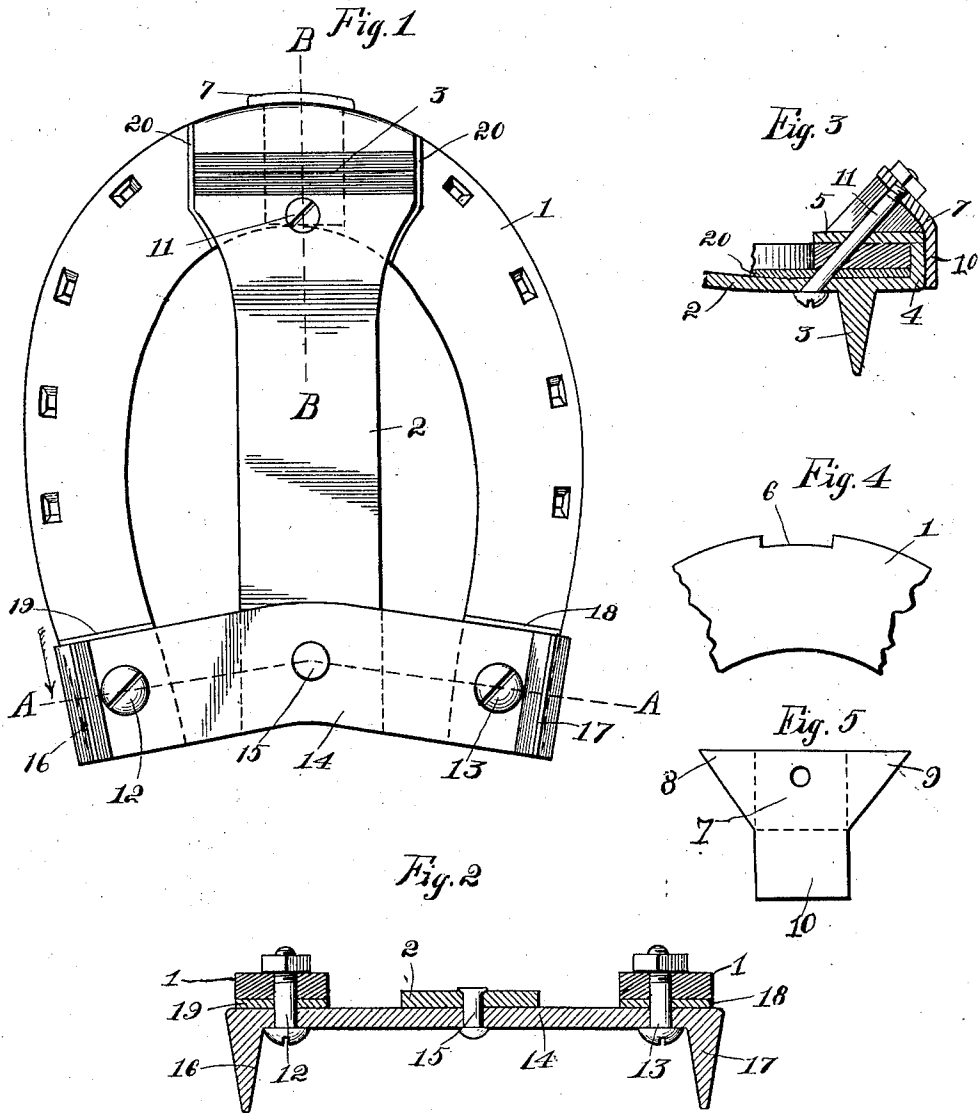

Witnesses:
R. C. Hamilton.
John S. Holzschuler

Inventor,
Emil Dargatz.
By Higdon & Higdon Attys

UNITED STATES PATENT OFFICE.

EMIL DARGATZ, OF KANSAS CITY, MISSOURI.

PADDED SAFETY-PLATE FOR HORSESHOES.

No. 830,643.

Specification of Letters Patent.

Patented Sept. 11, 1906.

Application filed February 5, 1906. Serial No. 299,463.

To all whom it may concern:

Be it known that I, EMIL DARGATZ, a citizen of the United States, and a resident of the city of Kansas City, Missouri, have invented a new and useful Improvement in Padded Safety-Plates for Horseshoes, of which the following is a specification.

My invention relates to an improvement in padded safety-plates for horseshoes to be adjustably secured to the under side of the shoe to prevent slipping when in use.

To this end my invention consists of certain novel parts and combination of parts, which will be illustrated in the drawings, pointed out in the specification, and claimed in the claim.

Figure 1 is an inverted plan view of a horseshoe with my invention in position. Fig. 2 is a cross-section through the heel portion of the shoe, taken on line A A of Fig. 1, indicated by a dart. Fig. 3 is a longitudinal section taken on line B B through the toe of the shoe and the plate. Fig. 4 is the toe of the shoe, showing a notch or recess adapted to be engaged by a loop integral with the front end of a longitudinal plate. Fig. 5 is the configuration of a piece of metal adapted for an adjustable toe-clip which will be fully described.

1 designates the shoe. Extending longitudinally and central therewith is a plate 2. Integral with the plate is a spur or calk 3. At the front end of said plate and also integral therewith the metal is diminished and extended, looping around and lapping over on top of the shoe, (designated 4 and 5,) indicated by dotted lines on the plate 2. (Seen in Fig. 1.) In order to prevent lateral movement of said plate at this point, I have notched or cut a recess 6 in the toe of the shoe (seen at Fig. 4) of corresponding dimensions with the width and thickness of loop 4 and 5. I have further provided a binder or toe-clip 7, constructed of a piece of metal, secured to the

toe of the shoe with a bolt 11, having oppositely-extended ears 8 and 9, with a depending parallel portion 10 engaging over the toe of the shoe. Before placing it in position the extended ears are bent to right angles to the parallel portion 10, and when in position the ears rest on the portion 5 of the loop, as seen in Fig. 3, and are held in position by a bolt 11, passing upward through the plate 2 and the toe of the shoe, as also seen at Fig. 3.

Secured horizontally to the heels of the shoe 1 by means of bolts 12 and 13 is a cross-plate 14, which underlaps plate 2 and is made secure thereto by a rivet 15, as seen at Fig. 2. Said cross-plate is provided with spurs or calks 16 and 17, which are adapted to prevent slipping when in use, the same as calk 3. (Seen at Fig. 3.) I have further provided pieces of yielding material 18, 19, and 20 between the heels of the end of cross-bar 14 and between the end of bar 2 and the toe of the shoe 1, (clearly indicated at Figs. 2 and 3,) the object of these being to soften or mollify the effect of contact between the animal's foot and the earth when stepping.

I claim as my invention—

Safety-plate attachment for horseshoes of the character described, the combination of a horseshoe, a recess in the toe thereof, a longitudinal plate and a cross-plate, a diminished extension and a toe-calk integral with the longitudinal plate, calks integral with the cross-plate, flexible bearings between the plates at the heels and toe of the shoe, a toe-clip and a bolt adapted to bind the longitudinal plate to the toe of the shoe, substantially as described.

In testimony whereof I affix my signature in the presence of two witnesses.

EMIL DARGATZ.

Witnesses:

ELEANORE C. WALTON,
F. A. SMITH.