

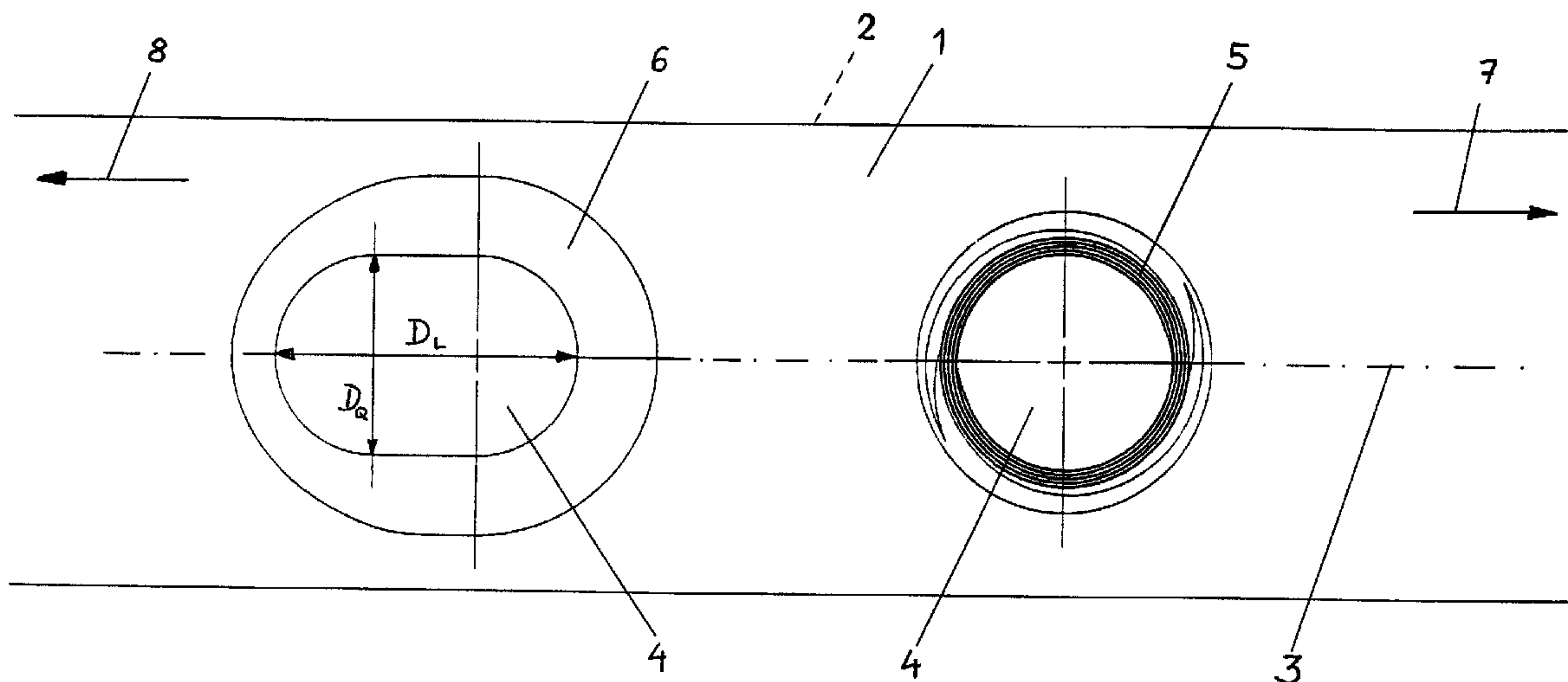

(86) Date de dépôt PCT/PCT Filing Date: 1999/03/09  
 (87) Date publication PCT/PCT Publication Date: 2000/09/14  
 (85) Entrée phase nationale/National Entry: 2001/09/10  
 (86) N° demande PCT/PCT Application No.: CH 1999/000106  
 (87) N° publication PCT/PCT Publication No.: 2000/053110

(51) Cl.Int.<sup>6</sup>/Int.Cl.<sup>6</sup> A61B 17/80  
 (71) Demandeur/Applicant:  
SYNTHES (U.S.A.), US  
 (72) Inventeurs/Inventors:  
SCHAVAN, ROBERT, DE;  
FRIGG, ROBERT, CH;  
WAGNER, MICHAEL, AT  
 (74) Agent: OSLER, HOSKIN & HARCOURT LLP

(54) Titre : PLAQUE POUR OSTEOSYNTHESE  
 (54) Title: BONE PLATE



(57) Abrégé/Abstract:

The inventive bone plate has a top surface (1), a bottom surface (2) for contact with the bone and several holes (4) which are situated along the longitudinal axis of the plate, connecting the top surface and the bottom surface (1, 2), for receiving bone screws (11). The diameter  $D_L$  of at least one of these holes (4) is greater in the direction of the longitudinal axis of the plate (3) than the diameter  $D_Q$  of said hole vertically in relation to the longitudinal axis of the plate (3). At least one of the holes (4) has an inner screw thread (5). This inner screw thread (5) extends over at least 180° of the geometrical body that it forms. The inventive bone plate can serve as a compression plate and as a so-called internal fixator at the same time, as effectively as if the two elements were separate.

Abstract

The bone plate comprises a top side (1) an underside (2) to make contact with the bone, and several holes (4) mounted along the longitudinal plate axis (3) and connecting the top side and the underside (1) and (2) to receive bone screws (11).

The diameter  $D_L$  of at least one of these holes (4) is larger along the longitudinal plate axis (3) than this hole's diameter  $D_Q$  transverse to the longitudinal plate axis (3). At least one of these holes (4) is fitted with an inside thread (5). This inside thread (5) subtends an arc of at least  $180^\circ$ .

The bone plate allows application as a compression plate and as a so-called inner affication system without entailing tradeoffs.

English translation of the International Patent Application PCT/CH99/00106 "Bone plate" in the name of Synthes AG Chur

**Bone plate**

The invention relates to as bone plate defined in the preamble of claim 1 and to an affixation system comprising such a bone plate as defined in the preamble of claim 15.

Basically there are two kinds of osteosyntheses implemented with bone plates.

The first kind relates to „rigid osteosynthesis“. Rigid osteosynthesis is used when treating fractures of joints, simple shaft fractures (where nailing is impossible), and also osteotomies. Aside anatomic repositioning ability, the bone per se supports the stability of osteosynthesis, resulting in earlier and more pain-free extremity-stressing. The advantages of stable fracture treatment also are observed where the blood circulation on account of trauma has been substantially reduced. When treating „non-unions“ or in the presence of infection, the fracture must be treated in stabilized manner to allow bone healing and to preclude further stimulating the infection by instability in the fracture gap.

The second kind relates to „flexible osteosynthesis“. The biggest advantages of flexible (biological) osteosynthesis relate to caring for comminuted fractures in the shaft zone of long bones. The goal relating to these fractures is keeping the bone lengths, and furthermore keeping the bone ends (joints), in their proper mutual positions. In this procedure the fracture zone is not directly affixed or manipulated, and consequently the blood circulation in this zone is not additionally hampered. The bone plates operate similarly to a locking, medullary pin solely anchored in the metaphyses.

These two extremes of plate osteosynthesis, they are indeed far apart. Fractures cannot always be assigned to either kind of osteosynthesis, and accordingly the surgeon frequently must compromise because no implant tradeoff is available to him when combining both methods. Such a combination for instance would be called for when a joint fracture can be compressed by means of tightening screws through the bone plate and the full joint part can be connected, by means of an inner affixation system, using angularly invariant screws to the diaphysis. Another application

illustratively concerns porous bones where a bone plate can be anchored by axially and angularly stabilized screws in the metaphysial fragment, stable plate affixation being possible in the diaphyseal range and being supported by a plate tightening screw passing through the fracture. Primary fracture stabilization can be achieved by this kind of care.

As a result, bone implants have been developed for both kinds of osteosynthesis and are now on the market. Both sets of implants are optimally designed for each method. The drawback of both systems therefore is that they cannot be combined.

Such a combined plate is known from the US Talos et al patent 5,709,686 wherein a cylindrical thread is present in the middle part of the elongated hole. The drawbacks of this known plate are the following:

- 1) The central position of the thread in the elongated hole of the plate restricts the range of the thread between 60 and 179°;
- 2) The central position of the thread in the elongated hole (clamping hole) of the plate is subject to the danger that the side webs of the elongated hole may widen; and
- 3) Because the thread is cylindrical, a special screw head must be used, that, when the screw is being tightened, can rest on the plate surface.

The objective of the invention is remedy. Its goal is to create a bone plate which combines both kinds of osteosynthesis without however entailing restriction on the care inherently afforded by the two plates per se. Accordingly the plate of the invention shall serve both as a compression plate and as a so-called inner affixation system without incurring tradeoffs.

The invention solves this problem by means of a bone plate as claimed in claim 1.

Using the plate of the invention as an inner affixation system results in much more stressing the interface of plate and screw because the plate is not forced against the bone and therefore the bone fracture is fixed on account of friction between the plate and the bone. This increase in stress is accounted for in that the thread in the elongated hole subtends a range of at least 180° and thereby will enclose the thread of

the screwhead by at least this angular range. This circumstance is especially significant where thin bone plates are involved.

In a further preferred development, the inside thread of the elongated hole conically tapers towards the underside of the bone plate. This embodiment offers the advantage that the screw affixation is implemented by the conical thread of the plate hole and by the matching conical thread of the screwhead used. This kind of affixation is especially important if self-drilling screws are used. Thanks to the conical thread in the head zone of the screw, this screw can be inserted into the bone independently of the plate. The screw shall be locked only when the threaded cone of the screwhead enters the inside thread of the plate's elongated hole. In spite of different thread beginnings in the plate hole's cone and in the bone, the conical screwhead thread will be centered in the plate's threaded cone.

When the conical thread is tightened, radial forces are generated in the plate hole. In order to adequately absorb these forces, the conical plate must be sufficiently dimensionally stable. Appropriately therefore the inside thread conically tapering toward the underside of the bone plate subtends a conical angle of 5 - 20°, typically of 10°.

In a further preferred embodiment, the holes defined by the features (a) and (b) are mutually identical and consequently the inside thread is fitted within a hole of which the diameter  $D_L$  measured in the direction of the longitudinal plate axis is larger than this hole's diameter  $D_Q$  measured perpendicularly to said longitudinal plate axis.

In another preferred embodiment of the invention, the inside thread, when seen in the direction of the longitudinal plate axis, is present at one of the two ends of the elongated hole. This position allows attaining an enlarged thread zone extending for instance to arcs from 190 to 280°, preferably from 200 to 250°.

Because the elongated hole is conical, there will be various values of the range of the inside thread at the underside or at the upper side of the plate. Measured at the underside, the arc of the thread preferably shall run from 180 to 230°, whereas measured at the top side it shall preferably run from 200 to 270°.

In a further preferred embodiment, the terminal, conical thread in the elongated hole (clamping hole) is present at that end which is nearest the center of the plate. This feature offers the advantage of leaving undegraded the clamping of the plate clamping holes.

As regards another preferred embodiment, at least one of the holes defined by feature (a) comprises at its upper portion facing the top side a concave and preferably spherical recess to receive a bone screw with a ballhead. This spherical screwhead of a conventional bone screw is optimally seated in this concave, spherical recess, foremost if the bone screw was inserted excentrically as required in fracture compression.

In a further preferred embodiment the underside is concave. Because of this concave underside, the plate better matches the round cross-section of the tibia, femur, humerus and lower arm bone. Because the plate underside is concave, it is possible to insert a conventional bone screw obliquely through the plate hole. Such a feature is important foremost when gripping a small bone fragment which must be pulled up to the plate.

In a further preferred embodiment, the inside thread runs over the full thickness of the bone plate from the underside to the top side in order to maximize dimensional stability.

In yet another preferred embodiment, the elongated hole flares in its thread-free sector, in its lower portion facing the underside, to allow bone-screw excursion.

In yet another preferred embodiment, the ratio of  $D_L/D_Q$  is within the range of 1.01 - 3.00, preferably in the range of 1.1 - 1.5. This ratio follows from the combination of the clamping hole, which requires some clamping path for the screw, with the threaded hole. The ascertained ratio of  $D_L/D_Q$  represents an optimal compromise between clamping effectiveness and minimal plate weakening by the combination hole.

Besides the bone plate of the invention, another embodiment additionally comprises at least one bone screw with an outer thread fitted on the screw head and matching the inside thread, said at least one bone screw preferably being self-drilling.

When the bone plate is used as a compression plate, the geometry of the clamping hole of the plate borehole is not adversely affected by the terminal, conical threaded hole. The advantage offered by the conical feature of the threaded hole 4 is that the screw can be inserted in plate-independent manner into the bone, the screw being connected to the plate by means of a threaded and matching screwhead only when the plate is being tightened. Such a feature is advantageous foremost when using self-tapping and self-drilling screws.

The invention and its further development are elucidated below in relation to the partly diagrammatical drawings of several illustrative embodiments.

**Fig. 1** is a topview of the bone plate of the invention comprising an unthreaded elongated hole and a separate threaded hole,

**Fig. 2** is a topview of the bone plate of the invention comprising an elongated hole with an integrated thread,

**Fig. 3** is a longitudinal section of the threaded hole of Fig. 1,

**Fig. 4** is a longitudinal section of the threaded elongated hole of Fig. 2, and

**Fig. 5** is a perspective of the bone plate of the invention with a bone screw inserted into the elongated hole with integrated thread.

The bone plate of the invention shown in Fig. 1 comprises a top side 1, an underside 2 that shall make contact with the bone and two holes 4 situated along the longitudinal plate axis 3 which shall receive the bone screws.

The arrow 7 indicates the direction toward one end of the bone plate and the arrow 8 points toward the center of the plate.

The diameter  $D_L$  of the hole 4 which is closer to the center of the plate when measured in the direction of the longitudinal plate axis 3 is larger than this hole's diameter  $D_Q$  measured perpendicularly to said axis 3. The diameter  $D_L$  is 5.2 mm and the diameter  $D_Q$  is 3 mm.

This elongated hole is fitted at its upper portion facing the top side 1 with a concave and preferably spherical recess 6 to receive a bone screw having a spherical head.

The hole 4 situated near the plate end comprises an inside thread 5 subtending an arc of  $360^\circ$ . In the artist's rendition of this embodiment, this plate hole assumes the shape of a cone tapering downward toward the underside 2, and accordingly the inside thread 5 also tapers downward toward the bone plate's underside 2 at a cone angle of  $10^\circ$ . Preferably the inside thread 5 is a double thread.

As shown in Fig. 3, the inside thread 5 of the hole 4 nearer the plate end runs along the full thickness of the bone plate from the top side 1 to the underside 2.

In the preferred embodiment of the invention shown in Figs. 2 and 4, the two bone-plate holes 4 of Fig. 1 are combined . as a result of which the inside thread 5 shall be inside both elongated holes 4. The thread 5 is situated at that end of the elongated hole which is nearer the center of the plate.

Furthermore the two elongated holes are the same as in the embodiment of Fig. 1.

Measured at the underside 2 and as indicated by the arc of circle 9, the inside thread 5 subtends an arc of  $223^\circ$  and when measured at the top side 1 and as indicated by the arc of circle 10 subtends an arc of  $256^\circ$ .

The table below the preferred parameters depending on the diameter of the inside thread 5.

Fig. 5 shows an affixation system fitted with a bone plate as shown in Fig. 4, wherein a bone screw 11 comprising an outside thread 12 at the screwhead 13, said outside thread 12 matching the bone-plate's inside thread 5. Appropriately the bone screw 12 is self-drilling and self-tapping.

thread diameter	3.0 mm	4.0 mm	5.0 mm
double thread	yes	yes	yes
pitch of thread	0.7 [mm]	0.9 [mm]	1.0 [mm]
depth of thread (= ½ of outside/inside diameter- differential)	0.2025 [mm]	0.2575 [mm]	0.2810 [mm]
angular excursion (at top side)	200°	200°	190°
angular excursion (at underside)	260°	240°	250°

CLAIMS

1. A bone plate comprising a top side (1), an underside (2) that shall make contact with the bone, and several holes (4) from the top side (1) to the underside (2) and configured along the longitudinal plate axis (3) and receiving bone screws (11), where
  - a) the diameter  $D_L$  of at least one of these holes (4) when measured in the direction of the longitudinal plate axis (3) is larger than the diameter  $D_Q$  of this hole perpendicularly to the longitudinal plate axis (3), and
  - b) at least one of these holes (4) is fitted with an inside thread (5), characterized in that
  - c) the inside thread (5) subtends an arc of at least  $180^\circ$  of the geometric body defined by it.
2. Bone plate as claimed in claim 1, characterized in that the inside thread (5) tapers conically in the direction of the underside (2) of the bone plate.
3. Bone plate as claimed in either of claims 1 and 2, characterized in that the inside thread (5) subtends an arc of  $190$  to  $280^\circ$ .
4. Bone plate as claimed in claim 3, characterized in that the inside thread (5) subtends an arc at least of  $200$  to  $250^\circ$ .
5. Bone plate as claimed in one of claims 1 through 4, characterized in that when measured at the underside (2) the inside thread runs across an arc of  $180$  to  $230^\circ$  and when measured at the top side (1) it runs across an arc of  $200$  to  $270^\circ$ .
6. Bone plate as claimed in one of claims 1 through 5, characterized in that the holes (4) defined by the features (a) and (b) are mutually identical whereby the inside thread (5) is fitted inside a hole (4) of which the diameter  $D_L$  when measured in the direction of the longitudinal plate axis (3) is larger than the diameter  $D_Q$  of this hole (4) measured perpendicularly to the longitudinal plate axis (3).

7. Bone plate as claimed in claim 6, characterized in that when seen in the direction of the longitudinal plate axis (3), the inside thread (5) is situated at one of the two ends of the elongated hole (4) defined in feature (a), preferably nearer the plate's center (8).
8. Bone plate as claimed in one of claims 1 through 7, characterized in that at least one of the holes (4) defined in feature (a) comprises a concave and preferably spherical recess (6) in its portion facing the top side (1) to receive a bone screw (11) having a spherical head (13).
9. Bone plate as claimed in one of claims 1 through 8, characterized in that the underside (1) is concave.
10. Bone plate as in one of claims 1 through 9, characterized in that the inside thread (5) runs through the full thickness of the bone plate from the top side (1) to the underside (2).
11. Bone plate as claimed in one of claims 1 through 11, characterized in that the hole (4) flares in its unthreaded sector in its lower portion facing the underside (2).
12. Bone plate as claimed in one of claims 1 through 11, characterized in that the ratio of  $D_L/D_Q$  is in the range of 1.01 to 3.00.
13. Bone plate as claimed in claim 12, characterized in that the ratio of  $D_L/D_Q$  is in the range of 1.1 to 1.5.
14. Bone plate as claimed in one of claims 2 through 13, characterized in that the cone angle of the inside thread (5) conically tapering toward the bone plate's underside is between 5 and 20°.
15. An affixation system comprising a bone plate claimed in one of claims 2 through 14, characterized in that in addition it comprises at least one bone screw (11) fitted with an outer thread (12) at the screwhead (13), said outer thread (12) matching the inside thread (5).

16. Affixation system as claimed in claim 15, characterized in that the bone screw (11) is self-drilling.

17. Affixation system as claimed in either of claims 15 and 16, characterized in that the bone screw (11) is self-tapping

1/4

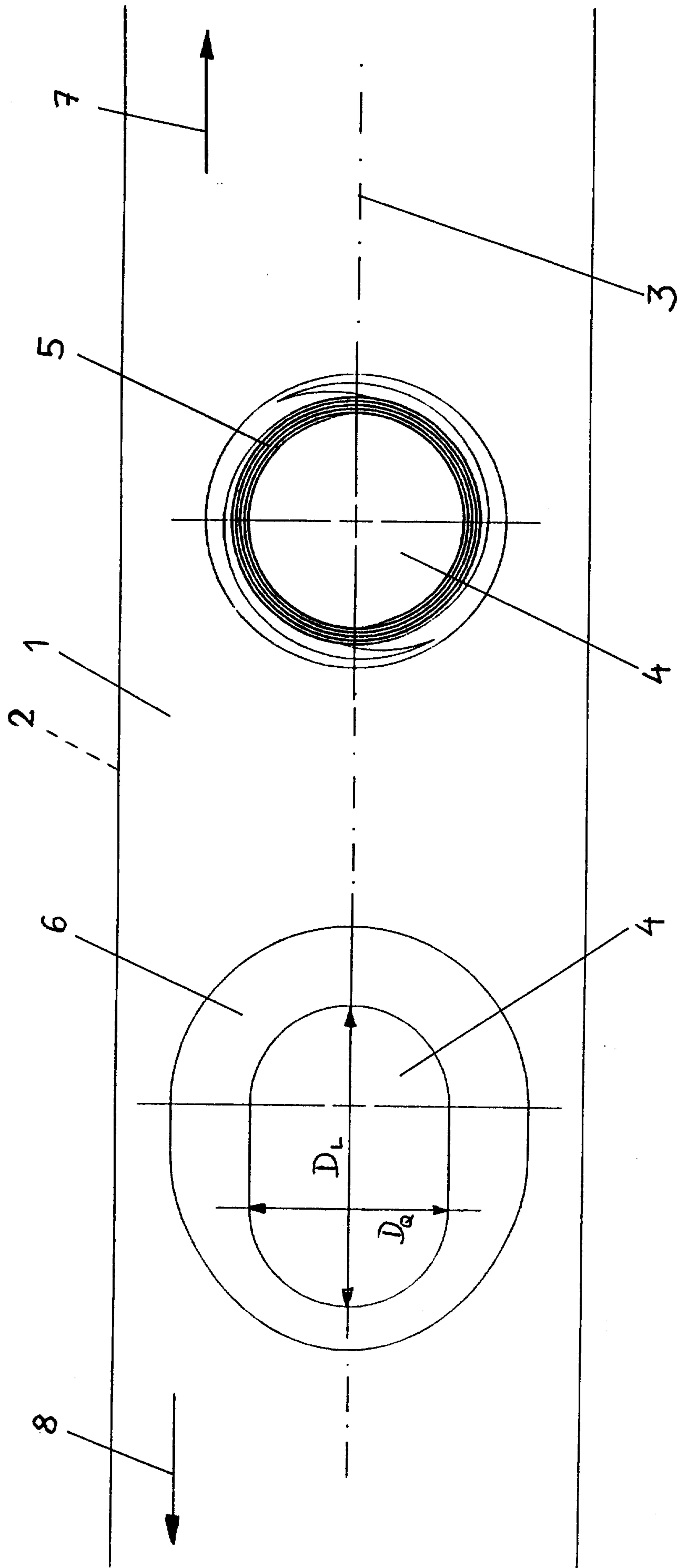

Fig. 1

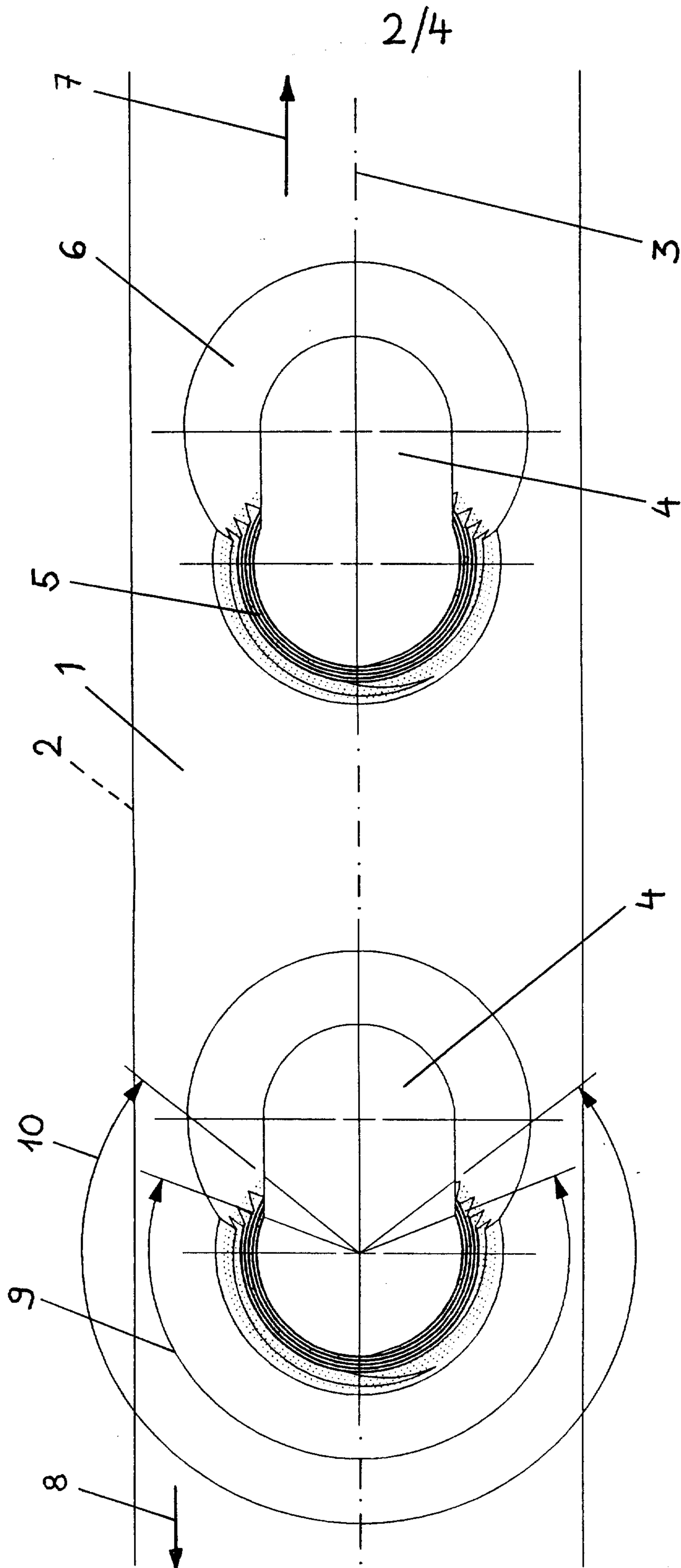

Fig. 2

3/4

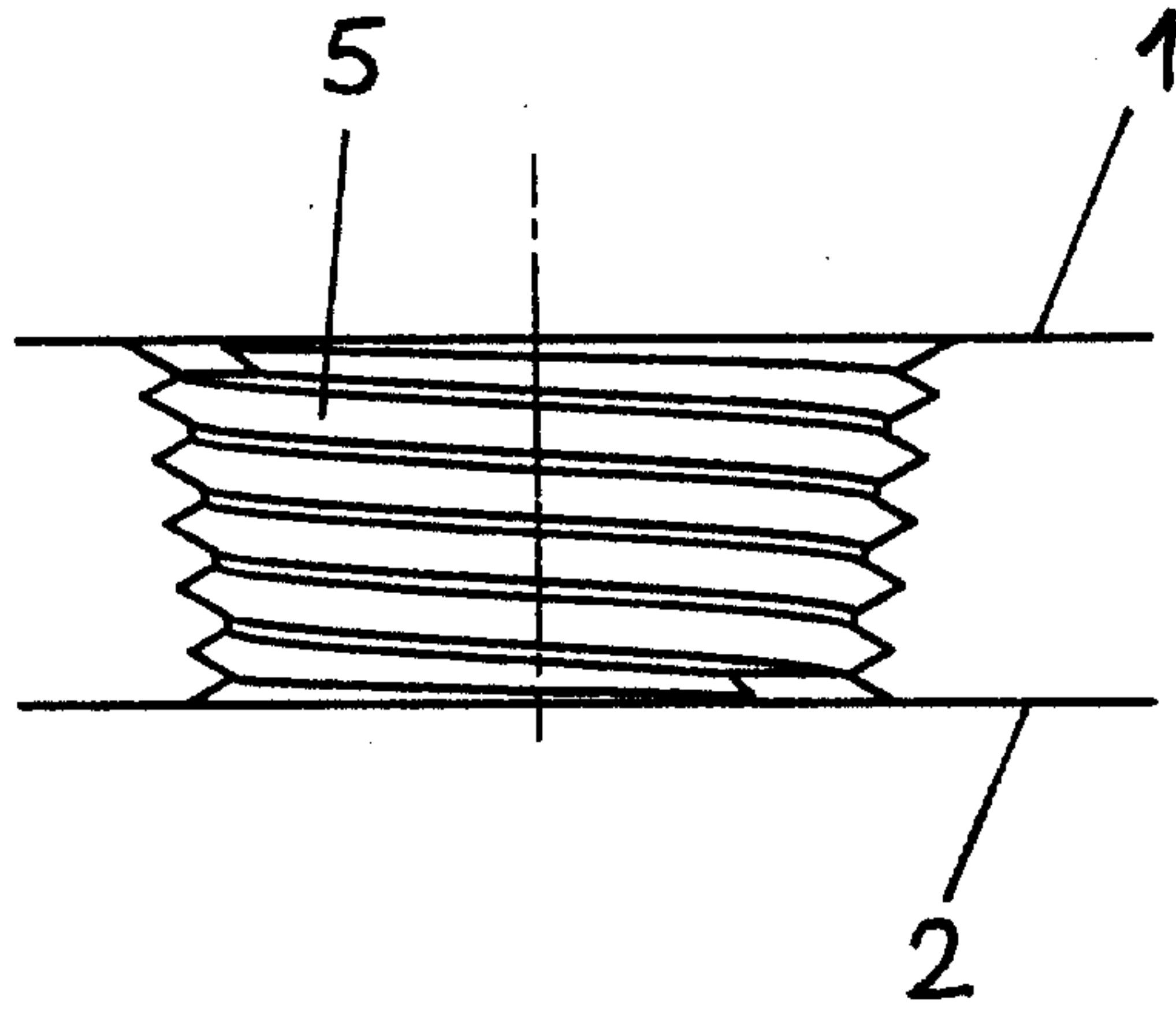

Fig. 3

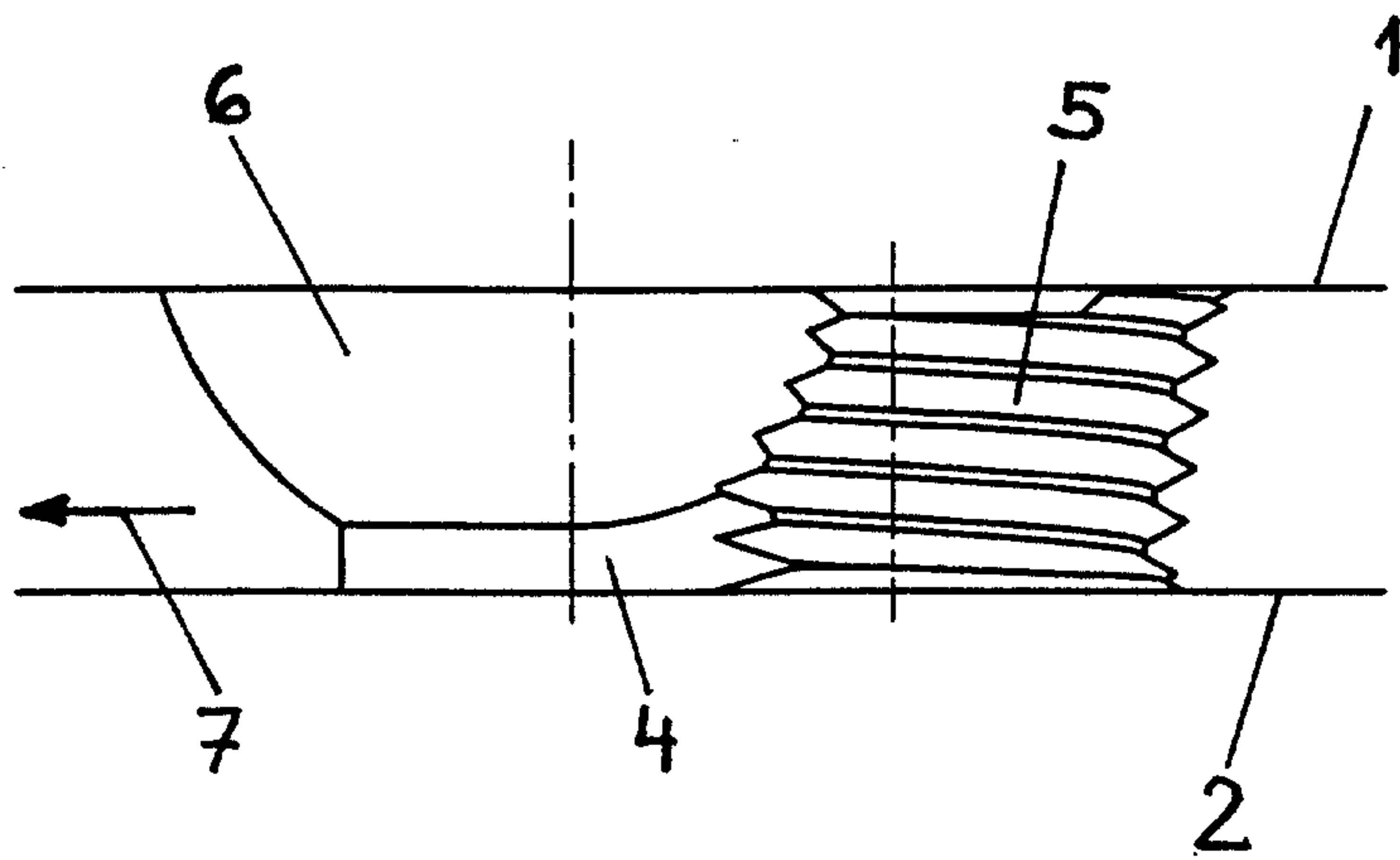

Fig. 4

4/4

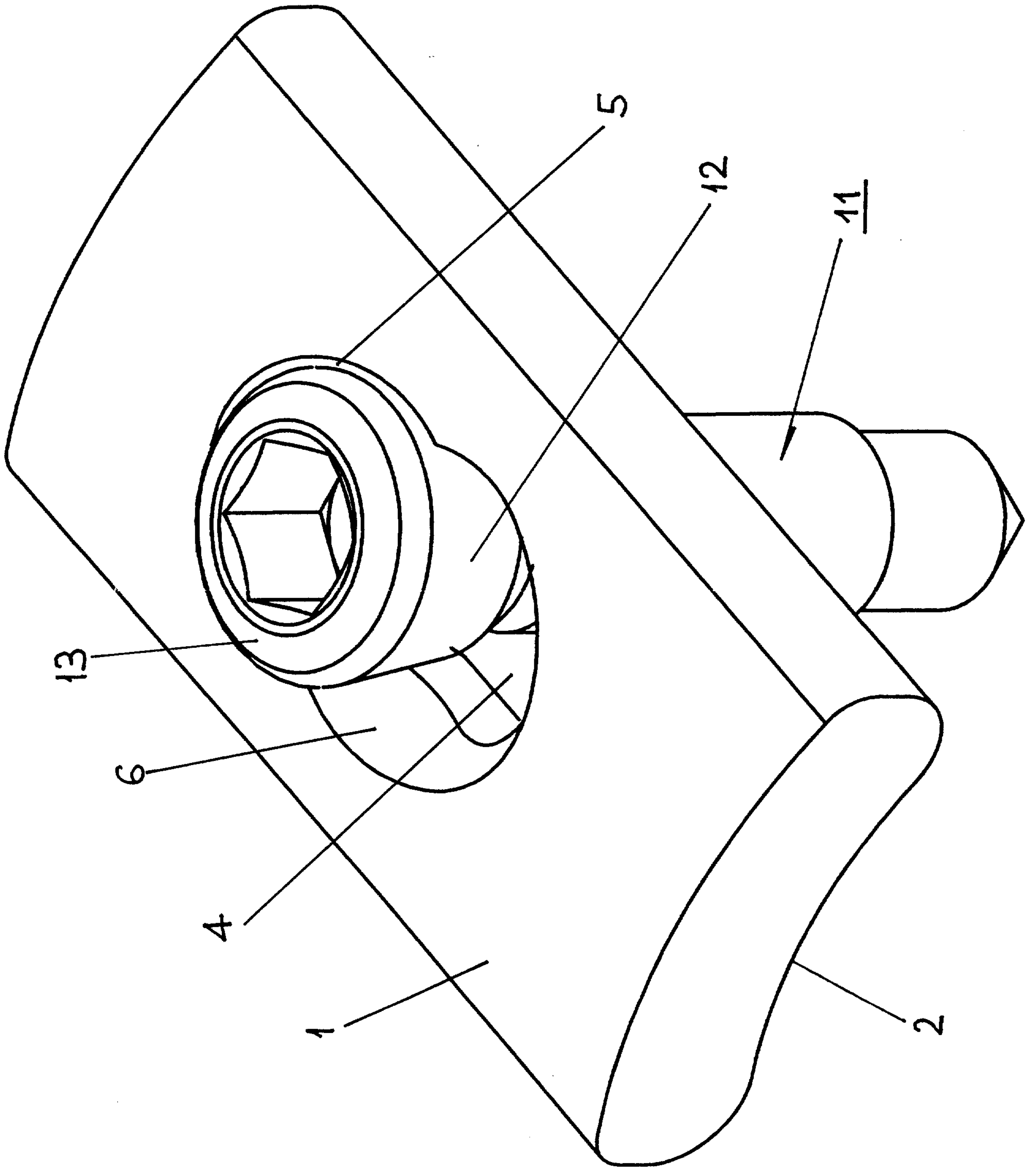

Fig. 5

