

(No Model.)

C. HALL.
PIPE WRENCH.

No. 523,810.

Patented July 31, 1894.

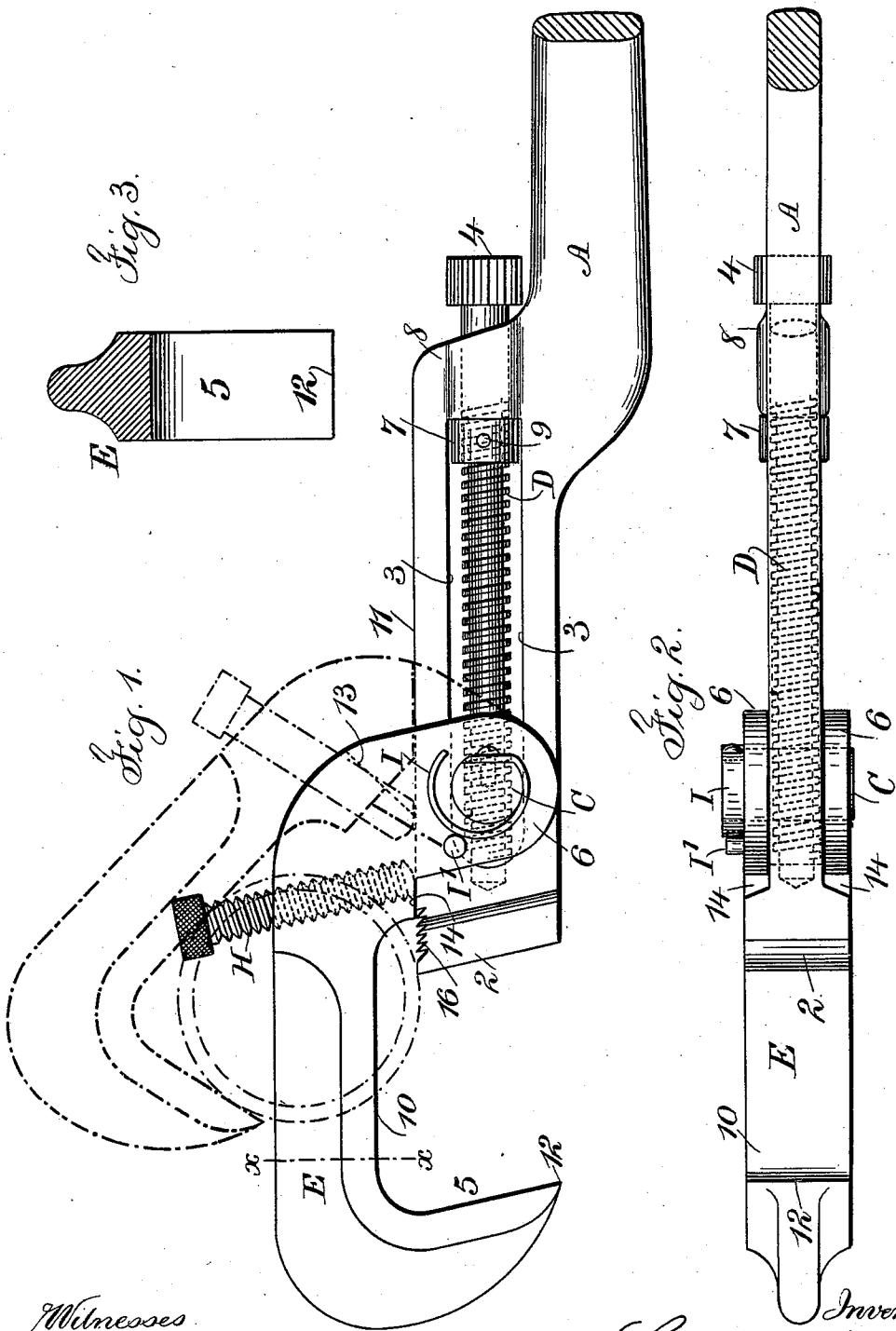

Witnesses
Charles Smith
J. Stait

Inventor
Charles Hall
per Lemuel W. Ferrell
Atty

UNITED STATES PATENT OFFICE.

CHARLES HALL, OF NEW YORK, N. Y.

PIPE-WRENCH.

SPECIFICATION forming part of Letters Patent No. 523,810, dated July 31, 1894.

Application filed March 5, 1894. Serial No. 502,310. (No model.)

To all whom it may concern:

Be it known that I, CHARLES HALL, a citizen of the United States, residing in the city, county, and State of New York, have invented an Improvement in Pipe-Wrenches, of which the following is a specification.

The present invention is a modification of an improvement upon the wrench represented in my Patent No. 516,485, dated March 13, 1894.

In the present invention I make the lever handle with an offset or bend adjacent to the end of the screw that occupies a slot in said lever handle, so that the screw may be continued as a plain circular rod through a hole at the offset or shoulder so that the actuating head for the screw comes at one side of the handle and adjacent to the shoulder, thereby rendering it unnecessary to provide separate bearing pieces as in my aforesaid application, and I make the interior side of the hook with an offset to allow for the introduction of a larger sized pipe without the necessity of projecting the point of the hook beyond the line of the lever handle when the swinging jaw is brought up against the opposite edge of the lever handle, at which place such swinging jaw is provided with a stop. I make use of a spring tending to turn the swinging jaw toward the lever handle, so as to prevent such swinging jaw dropping away from the position in which it is made use of.

In the drawings, Figure 1 is a side view of my improved wrench, partially in section. Fig. 2 is an elevation at right angles to Fig. 1, and Fig. 3 is a section at the line $x x$ of Fig. 1.

The lever handle A is made with a jaw 2 at the end thereof, the surface of which is at an acute angle so as to form a chisel edge adapted to press against the pipe or rod when the same is being rotated, and this lever handle A is formed with a longitudinal slot 3 into which is received the screw D, and such screw passes through the lever handle at the offset or shoulder 8 and terminates with a head or burr 4 by which the screw may be rotated, and the circular point of the screw is received in a recess at the end of the slot 3 and near the jaw 2, and to prevent the screw D slipping out of place there is a collar 7 surrounding such screw and preferably inter-

nally screw-threaded so that the screw is screwed through the collar and takes a bearing at the back end of the slot 3 to hold the screw in place; and it is advantageous to insert a pin 9 through the collar and through the screw D to hold the collar in place, and the portion of the screw shank or rod which passes through the handle A at the offset 8, is preferably cylindrical and as large as the screw-thread, so that the screw may be inserted through the hole in the handle and screwed into the collar 7 and also into the pivot C which is in the form of a nut sliding in the aforesaid groove 3 as in my aforesaid application.

The hook-shaped jaw E is slotted at the back end so that the plate portions 6 pass at each side of the handle lever A, and the pivot C passes through holes in the portion 6 of the jaw E, so that such jaw E swings upon the pivot C in receiving and acting upon the pipe or other round article.

When the jaw E is in the position represented in Fig. 1, the surface 5 of the hook-shaped jaw E is parallel with the surface 2 of the jaw at the end of the handle lever, so that the wrench can be used with nuts or bolt heads or other polygonal articles, but instead of the longitudinal inner surface of the hook being in line with the edge of the handle lever and jaw, I make an offset so that the surface 10 of the swinging hook E is sufficiently distant from the surface 11 of the handle lever for the reception of the largest sized pipe to which the wrench is adapted, and at the same time the point 12 of the hook will lap sufficiently upon such pipe to prevent the hook slipping and disengaging its hold upon the pipe, as indicated by dotted lines in Fig. 1; it being important that the point 12 of the hook E should be in line or nearly so with the edge of the handle bar, so as to coincide with the jaw 2 at the end of such handle bar when the hook is brought down into contact therewith.

The bottom portion 14 of the slot between the portions 6 of the swinging jaw E forms a stop against the surface 11 of the handle bar when the hook jaw E is swung up into the position shown in Fig. 1, and the bottom 13 of the slot between the portions 6 of the jaw E forms a stop to prevent the jaw E being

swung back too far, as illustrated by the dotted lines, and in order to accurately adjust the position in which the swinging jaw E may be stopped in its relation to the handle bar and its jaw when grasping a pipe, I employ the screw H passing through the swinging jaw at or adjacent to the surface 14 and pressing against the edge 11 of the handle bar jaw, and this screw H should work easily so that it can be rotated by hand as the wrench is applied to the pipe so that when the handle bar jaw presses against the pipe with the desired force, the screw H can be turned in to take a bearing against the surface 11 and prevent the pipe being crushed by undue pressure against the side thereof.

When the handle is moved in such a direction as to release the grip upon the pipe, the jaw E may swing away from the pipe and the wrench lose its hold thereon. To keep the jaw E up to its work, I provide a spring I one end of which is connected to the pivot C, and it is advantageously made in the form of an arc of a circle to act against a pin I' upon the jaw E to move the hook end of the jaw E toward the position shown by full lines in Fig. 1, and this is also advantageous when the jaws of the wrench are applied to turn a nut or other polygonal article, because the spring I holds the jaw E in the normal position for the reception of such nut or polygonal article between the surface 5 of the hook E and the inclined end 2 of the handle lever.

To lessen the weight of the swinging jaw E, the back edges of such jaw are beveled or formed as a rib with concave surfaces, as shown in cross section Fig. 3, thereby maintaining the proper width of operative surface upon said swinging jaw, and the necessary strength with as little weight as possible.

In cases where it is desired, teeth 16 may be provided along the side of the handle bar adjacent to the jaw 2, so as to act upon pipes of large diameter.

I claim as my invention—

1. The combination with the hook-shaped swinging jaw, of a pivot, a handle bar having a jaw at the end, a longitudinal mortise for the pivot of the swinging jaw, an offset in the handle, and a screw acting upon the pivot pin and passing through the handle bar at the offset thereof and acting longitudinally within the mortise, substantially as set forth.

2. The combination with a handle bar having a jaw at the end thereof and a longitudi-

nal mortise, of a screw within the mortise, a pivot pin against which the screw acts, a jaw having a hook at one end and receiving the pivot pin at the other end and slotted for the reception of the handle bar, the bottom 14 of the slot forming a stop against the side of the handle bar when the swinging jaw is in its normal position, substantially as set forth.

3. The combination with a handle bar having a jaw at the end thereof and a longitudinal mortise, of a screw within the mortise, a pivot pin against which the screw acts, a jaw having a hook at one end and receiving the pivot pin at the other end and slotted for the reception of the handle bar, the bottom 14 of the slot forming a stop against the side of the handle bar when the swinging jaw is in its normal position, such swinging jaw having an offset at 10 by which the effective length of the hook-shaped jaw at the end is increased to adapt the wrench to the larger sizes of pipe, substantially as set forth.

4. The combination with a handle bar having a jaw at the end thereof and a longitudinal mortise, of a screw within the mortise, a pivot pin against which the screw acts, a swinging jaw slotted at one end for the reception of the handle bar, a stop screw H passing through the swinging jaw and acting against the edge of the handle bar for arresting the movement of the parts after the pipe has been grasped, substantially as set forth.

5. The combination with a handle bar jaw slotted longitudinally, a pivot pin in the slot and a screw acting upon the pivot pin, of a swinging jaw slotted at one end and having holes through which the pivot pin passes, and a spring connected with the pivot pin and acting to move the swinging jaw toward the lever handle, substantially as set forth.

6. The combination with the swinging hook-shaped jaw slotted at one end, of a handle bar having a jaw at the end thereof and a slot for the pivot pin, an offset in the handle a screw passing through the offset and through the pivot pin and into a recess at the jaw end of the slot, and a collar around the screw at the other end of the slot for retaining the screw in position, substantially as set forth.

Signed by me this 27th day of February, 1894.

CHAS. HALL.

Witnesses:

GEO. T. PINCKNEY,
A. M. OLIVER.