

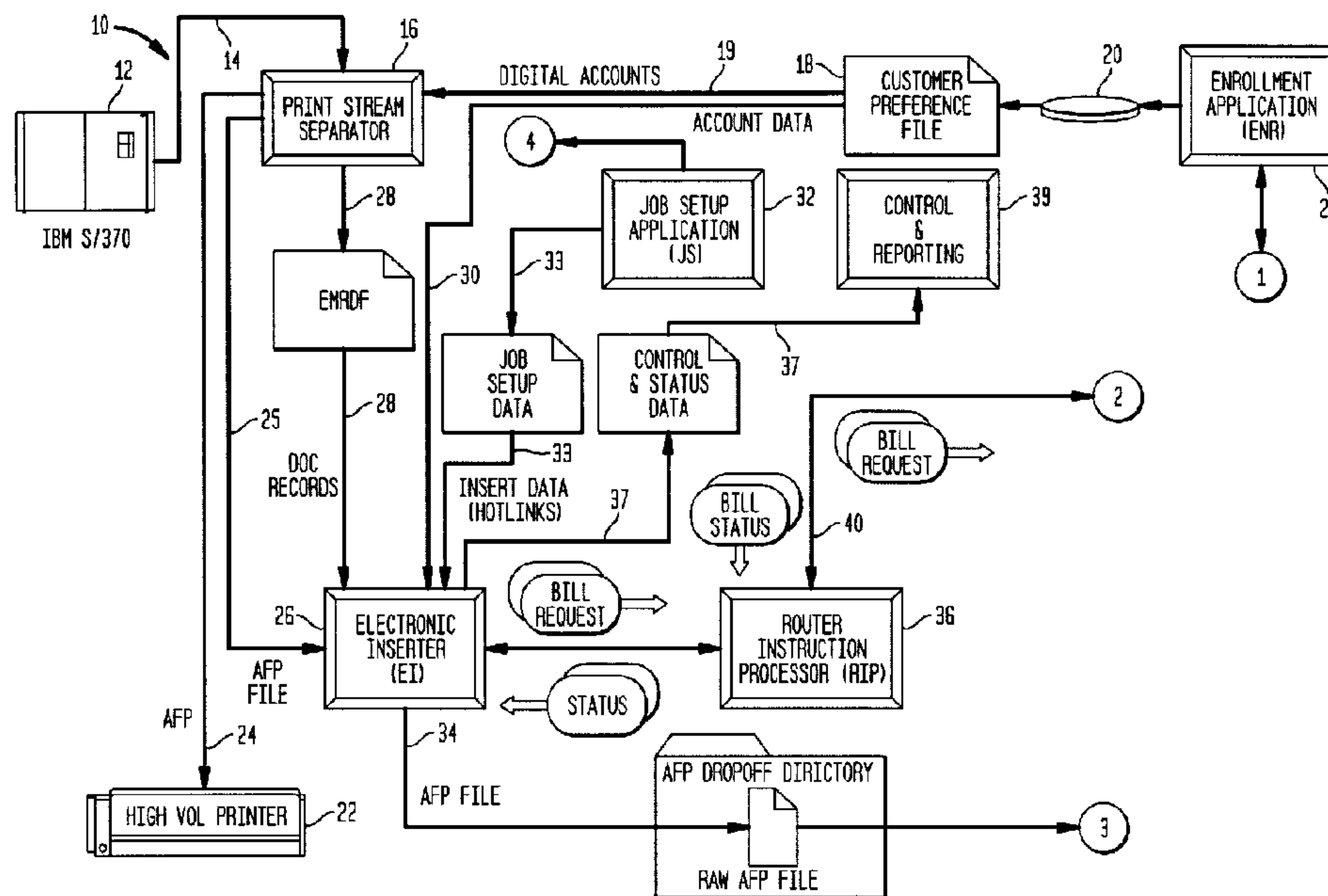

(22) Date de dépôt/Filing Date: 1999/12/24
 (41) Mise à la disp. pub./Open to Public Insp.: 2000/06/29
 (45) Date de délivrance/Issue Date: 2003/11/04
 (30) Priorité/Priority: 1998/12/29 (09/222528) US

(51) Cl.Int.⁷/Int.Cl.⁷ H04L 12/54, B41F 19/00
 (72) Inventeurs/Inventors:
 WOODMAN, CLARE E., US;
 GARDNER, DAVID P., US
 (73) Propriétaire/Owner:
 PITNEY BOWES INC., US
 (74) Agent: SIM & MCBURNEY

(54) Titre : SYSTEME ET METHODE DE SEPARATION D'UN FLOT D'IMPRESSION EN UN FLOT D'IMPRESSION DE DOCUMENTS ELECTRONIQUES ET UN FLOT D'IMPRESSION DE DOCUMENTS PAPIER
 (54) Title: SYSTEM AND METHOD FOR SEPARATING A PRINT STREAM INTO AN ELECTRONIC DOCUMENT PRINT STREAM AND A PHYSICAL DOCUMENT PRINT STREAM



(57) Abrégé/Abstract:

An apparatus for separating print stream data containing a plurality of primary documents and information concerning associated customers to receive the documents, wherein the apparatus receives customer preference data that allow separation of the print stream data into an electronic primary document print stream and a hard copy primary document print stream. The print stream separator further generates a second output for the customers that are to receive their primary documents by electronic delivery, where this second output contains information regarding which of a plurality of secondary documents the customer should receive with the primary document. The priorities of these secondary documents may be based upon specific customer preference data for the specific customer receiving his or her primary document. Priorities for these secondary documents can also be included in this second output. A method corresponding to this apparatus is also described.

**SYSTEM AND METHOD FOR SEPARATING A PRINT STREAM INTO AN
ELECTRONIC DOCUMENT PRINT STREAM AND A PHYSICAL
DOCUMENT PRINT STREAM**

Abstract of the Disclosure:

5 An apparatus for separating print stream data containing a plurality of
primary documents and information concerning associated customers to
receive the documents, wherein the apparatus receives customer preference
data that allow separation of the print stream data into an electronic primary
document print stream and a hard copy primary document print stream. The
10 print stream separator further generates a second output for the customers
that are to receive their primary documents by electronic delivery, where this
second output contains information regarding which of a plurality of
secondary documents the customer should receive with the primary
document. The priorities of these secondary documents may be based upon
15 specific customer preference data for the specific customer receiving his or
her primary document. Priorities for these secondary documents can also be
included in this second output. A method corresponding to this apparatus is
also described.

**SYSTEM AND METHOD FOR SEPARATING A PRINT STREAM INTO AN
ELECTRONIC DOCUMENT PRINT STREAM AND A PHYSICAL
DOCUMENT PRINT STREAM**

Background of the Invention

5 In the development of a digital data delivery system, it is found that an analog to the physical generation of a printed document is advantageous for acceptance of an electronic version of the document for presentation to an end-user such as a customer receiving for instance, a bill from a company with which that customer does business. In many legacy computer systems,
10 mainframe computers are used to generate print stream information in one of a plurality of formats, including the AFP file format. It is thus desirable to be able to use such a file format as the basis for generating electronic document in a digital document delivery system.

Summary of the Invention

15 A print stream separator according to the present invention receives print stream data from an associated generator of such information, such as a legacy mainframe computer print stream output. Such information in a typical application may contain a plurality of customer bills for presentation to the customers of a particular company. Bill information and accompanying customer account information form at least part of this print stream. Such
20 information in the past would generally be directed to a high speed, high volume printer in a particular file format such as the AFP file format for generation of the customer bills with insertion of one or more hard copy inserts, typically of an advertisement or informational nature. Such inserts are put into the customer's bill based upon information concerning the identified
25 customer as derived from a customer preference database and with the specific inserts being determined based upon a prioritization in view of information received from the customer preference database so as to maintain a certain weight limit for the hard copy mailing.

30 The present invention provides a print stream separator which receives the initial print stream data, as well as information from a customer

preference database. The print stream separator then determines which documents are to be generated in electronic form and which are to be directed to a high speed, high volume printer, such that the data presented to the high speed, high volume is separate and distinct from the data sent for
5 ultimate presentation and viewing in electronic form. Information within the customer preference file for each customer is the basis upon which a determination is made as to directing the print stream either to the high speed, high volume printer or to an electronic inserter for presentation in electronic form.

10 If the data is to be presented in electronic form, the print stream separator generates two outputs, a first output representing the customer primary document to be ultimately viewed by the customer, as well as an Electronic Mail Run Data File (EMRDF), which includes a header and fields containing information directed to that customer and the preference of inserts
15 to be generated with the primary document for that customer. Both the electronic document print stream and the EMRDF document record for the customer are then presented to the electronic inserter, which in turn receives job setup data from an associated job setup application module, including information for links associated with particular inserts to be associated with
20 the customer's primary document. The electronic inserter generates an output print stream in an AFP file format containing the primary document information. The EMRDF file is communicated to the router instruction processor (RIP) and contains information regarding specific links for "inserts" (secondary documents) which are to be associated with the primary
25 document.

As more fully described in co-pending Canadian patent application number 2,293,764 entitled System and Method for Presenting and Processing Documents on the Internet, filed on the same date herewith, and assigned to the same assignee, the print data stream from the electronic inserter is
30 presented to an interactive bill presentation server (IBPS), under the control of a bill processing server (BPS). The IBPS output is ultimately presented to a

customer having access to a computer with an associated web browser so as to allow view of the primary document and the associated inserts. The customer can, after viewing the primary document (which typically would be in the nature of a bill), respond to the primary document (bill) such as to make payment thereof. This response information is processed by the overall digital document delivery system by means of the bill processor server which updates the customer's account database such as to indicate payment of a bill or the like.

According to one object of an aspect of the present invention there is provided an apparatus for separating print stream data containing a plurality of primary documents and information concerning associated customers for receipt of each primary document, said print stream data to be separated into at least two data paths by said apparatus, one path of which is for electronic delivery of an electronic primary document with N secondary documents inserts, where N is a non-negative integer including 0, said apparatus comprising a print stream separator having:

A) means for receipt of the print stream data and means for receipt of customer preference data regarding at least some of the customers to which said print stream is directed;

B) means based upon the customer preference data for determining if a particular primary document in the print stream is intended for electronic delivery to the associated customer and if so, generate an output of the print stream for electronic delivery thereof; and

C) means for generating an output for the remaining print stream data for non-electronic delivery thereof;

wherein the means for determining if a particular primary document is intended for electronic delivery further has means for generating a second output related to the control and preferences of any secondary documents to be associated with the primary document, the second output containing information regarding which secondary documents can accompany the primary document and respective priorities of the secondary documents that can accompany the primary document.

According to another object of an aspect of the present invention there if provided a method for separating print stream data containing a plurality of primary documents and information concerning associated customers for receipt of each primary document, said print stream data to be separated into at least two data paths, one path of which is for electronic delivery of an electronic primary document with N secondary documents inserts, where N is a non-negative integer including 0, said method comprising the steps of:

- A) receiving the print stream data and receiving the customer preference data regarding at least some of the customers to which said print stream is directed;
- B) based upon the customer preference data, determining if a particular primary document in the print stream is intended for electronic delivery to the associated customer and if so, generating an output of the print stream for electronic delivery thereof;
- C) generating an output for the remaining print stream data for non-electronic delivery thereof; and
- D) for the print stream intended for electronic delivery, prioritizing any secondary documents that are to be sent to the customer, such that some secondary documents are given higher priority for inclusion or positioning than other secondary documents.

Brief Description of the Drawings

Figure 1A and 1B form an overall block diagram of a digital document delivery system according to the present invention illustrating the print stream separator and the associated electronic inserter forming part of the overall system and method.

Figure 2 is a block/flow diagram of the electronic inserter and router instruction processor shown in Figures 1A and 1B.

Figure 3 is a block/flow diagram of the router instruction processor, bill processing server and interactive bill presentment server shown in Figures 1A and 1B

Detailed Description

As used throughout this description, the words "user" and "customer" are synonymous as are the words "bill" and "primary document" and the words "insert" and "secondary document". Definitions of acronyms are presented in Table 1.

Figures 1A and 1B form an overall block diagrams of a digital document delivery system of which the print stream separator **16** and electronic insert **26** form a part thereof. Full disclosure concerning the overall operation of the digital document delivery system is presented in the previously mentioned Canadian patent application number 2,293,764 entitled: System and Method for Presenting and Processing Documents on the Internet.

The present invention is specifically directed to the mechanism by which a print stream generated by a computer system or the like such as a legacy mainframe computer **12** can be used as the input to a print stream separator so as to separate this print stream into a first print stream **24** intended for hard copy printing via a high speed, high volume printer **22** and a second print stream **25** intended for ultimate electronic delivery. The data

20

emanating from the computer on output **14** typically represents a print stream of primary documents such as bills for customers of a public utility or the like. It is desired to be able to identify those documents which are intended for electronic distribution and to separate these documents from the print stream **14** so as to be deliverable in electronic form, while the remaining documents which are intended for hard copy printing are directed to the second print stream **24**.

The print stream separator based upon customer information in the print stream **14** (which may be the customer's account number with the proprietor of the digital document delivery) identifies those documents intended for electronic delivery by comparing such information with information received from the customer's preference file **18** via a communication path **19**, and thereby creates a separate electronic print stream **25** for such documents.

Likewise, the print stream separator generates the first print stream **24** intended for hard copy printing, which excludes those documents intended for electronic printing.

Furthermore, the print stream separator generates an Electronic Mail Run Data File Specification (EMRDF) which contains control and preference information with respect to those electronic documents presented on output **25**. The electronic inserter **26** receives both the electronic print stream data **25** and the EMRDF data output **28**. The electronic inserter generates an electronic output print stream on output **34** which contains information regarding the electronic primary document to be presented to the customer. The EMRDF file containing information concerning any additional secondary documents known as "inserts" which are intended to be delivered with the primary document to that customer, are presented to the router instruction processor (RIP) **39**. This technique is thus an electronic analog of the output generated by the high speed, high volume printer **22**, which is also able to insert additional documents with the primary document based upon information received in the print stream **24**. For hard copy, this result is performed by what is known in the art as an inserting system which inserts documents with the primary document, such as advertising inserts,

accompanying a customer bill with the specific inserts based upon a customer preference file.

5 The customer preference file **18** may contain information concerning the customer such as the customer's sex, age, interests and the like. This information can be used by the electronic inserter to determine which of the inserts are of potentially the greatest interest to that customer and thus gives higher priorities to those inserts.

10 The electronic analog does not necessarily need to generate the electronic equivalent of such secondary documents (inserts) but rather need only contain links which can be used by the customer with an associated computer executing an Internet browser for using those links to access the specific insert information and viewing same on the customer's browser.

15 The electronic inserter also receives general customer information from the customer preference file **18** stored in the customer preference database **20** via communication path **30**. This information, for instance, can include the customer's e-mail address, facsimile number, beeper number, resident address and the like. It can also include the customer's preference for bill notification; such as e-mail as the first preference, and fax message as the second preference. Some of this information can be used to determine
20 how the customer is to be notified (e.g., E-mail, fax, beeper, regular mail) that a primary document is ready for viewing. If the customer does not view the primary document within a predetermined length of time, an alternative method of notification can be used.

25 Furthermore, the electronic inserter receives information from a job set up application module **32** via communication path **33** which contains information concerning potential inserts and their associated links which may form part of the print stream **34** for a specific customer, based upon that customer's preferences.

30 In this regard, reference is made to the details of the Electronic Mail Run Data File and how it is used by the electronic inserter to select inserts to accompany the primary document for a particular customer. The EMRDF is a file that is analogous to the MRDF file structure used with physical print inserters. The EMRDF is intended to contain information that is known only

to the mechanism that generates the print stream. Other files in the system have information about the customer, such as the customer database file 20, as well as specifics concerning the particular print job as contained in the job set up application module 32.

5 The EMRDF contains piece-level information for each document in the electronic print system. Its primary purpose is therefore to indicate which electronic insert(s) (secondary documents{s}) is to accompany the primary document, as well as the priority of that insert *vis-a-vis* other inserts. This information is translated into the equivalent of an electronic insert such as a
10 hypertext markup language (HTML) page or bit maps, or files in the PDF format, etc., as well as the relative importance for positioning the link to the insert with respect to the primary document.

 Priorities with regard to physical print inserts are normally based upon overall weight of the envelope and its contents and, from that, the inserts
15 typically have priority, such as "must have", which means that it is to be inserted if the weight of the overall envelope is under a predetermined amount, such as one ounce.

 For electronic presentation, priorities can be of a different nature, for instance, where on the primary document the link to the insert should be
20 displayed to the customer and the like. Thus, customers might want high priority inserts in a more visible location on the primary document than lower-priority inserts. Higher priority inserts may also contain JAVA language applets for making the insert more visible or pleasing to the customer. In general, priority data when used for electronic presentation is used by the
25 electronic insert decision-making algorithms for purposes of determining the location and number of inserts to be presented to the customer. The determination of an insert's priority can be fixed (i.e., the same for all customers) or it can be based upon information of the specific customer (i.e., the customer's age, sex, occupation, income level and the like). The
30 customer preference can form part of the customer preference data 18 transferred to the print stream separator 16.

 The customer preference data can also be used to determine the inclusion or exclusion of a particular secondary document. As seen in Table

3, parameter "Insertxx" (where "xx" is a number from 1 to 16) is a Boolean parameter which indicates the inclusion or exclusion of a particular insert. The customer preference file can, therefore, be used to set the true or false state of any of these parameters, which, in the example shown, has
5 information for sixteen inserts (Insert01 through Insert16).

The EMRDF file contains fields which are all of the type "character". The character set can vary depending upon where the EMRDF file is used and, thus, can be in the EBCDIC format when used for mainframe computer output and can be in the ASCII output when used on computer servers using
10 the Microsoft NT operating system or the UNIX operating system. Of course, if the EMRDF file is in the ASCII format and it is to be transferred to a mainframe, it would generally have to first be converted to the EBCDIC format.

The fields of the EBRDF file are typically left justified and padded with
15 blanks for the remainder of each field. The file consists of a header record with N piece records, where N is an integer up to some maximum number of primary documents for a given print job, such as ten million. Each of these record types is defined in Table 2. The records are terminated by two bytes containing carriage return (CR) and line feed (LF) characters (ASCII hex 0D
20 0A).

As set forth in Table 2, the specifics of the record are shown with regard to the header while Table 3 shows the specifics of the piece records. From these tables, it is clear that the inserts can have a priority based upon the number of inserts. In the preferred embodiment, the priority can be from
25 1 to 16 for each primary document.

As seen in Tables 2 and 3, the header record thus contains exactly 40 bytes and the piece record contains exactly 124 bytes. In the preferred embodiment of the invention, there can be up to ten million piece records in a given file.

30 As also seen in Figures 1A and 1B, the customer preference database is typically associated with an enrollment application module 27 which interacts with the user, typically over the Internet so as to update the customer preference data associated with a given customer. Such

information can include address information, interests of the customer, as well as any other pertinent information deemed necessary or desirable for the proprietor of the digital document delivery system.

5 In operation, the print stream separator, based upon customer preference data received from the customer preference database, determines which print documents should be separated from the overall print stream for presentation to the electronic inserter. Furthermore, based upon the customer preference data, the details of the Electronic Mail Run Data File can be determined for presentation to the electronic inserter.

10 Other data concerning the customer via the customer preference database can be communicated from this database via communication path 32 to the electronic inserter, such as the customer's e-mail address, preferences concerning document notification, and the like. Furthermore, as seen in Figures 1A and 1B, not only does the electronic inserter generate an
15 output print stream file, typically in an AFP format, but it also can generate control and status data via communication path 37 to a control and reporting module 39 with control and status data typically being generated by the electronic inserter for presentation to the controller reporting module. Such information can then be used to determine the status of a given print run, as
20 well as the nature of the customers and inserts associated with the primary documents sent to the customers in that particular print run.

The overall system thus comprises an efficient and convenient method for extracting documents for electronic delivery to customers from a print stream which contains print data, with the determination for extraction based
25 upon a customer preference database. Furthermore, the invention provides for the ability of generating links to other documents for presentation to the customer in electronic form based upon the preferences of the particular customer who is receiving the electronic primary document.

Module Details

30 Details of the modules described above so as to achieve the stated operation are presented in Table 4. Figure 2 shows a details of the modules as well as the objects and language protocols used in the preferred

embodiment of the present invention.

The print stream separator, electronic inserter, BPS and IBPS can be implemented on computer servers; e.g., Intel processor based servers using Microsoft Windows NT™ on UNIX™ operating systems. A high level object oriented language, e.g., Sun Microsystems' JAVA language, can be preferably used to implement the specific instructions for performing above-described tasks.

In the foregoing specification, the invention has been described as referenced to specific embodiments thereof. It will, however, be evident that various modification and changes may be made thereto without departing from the broader spirit and scope of the invention. The specification and drawings are, accordingly, to be regarded as illustrative rather than in a restrictive sense.

Table 1

ACRONYMS	DEFINITIONS
ACH	Automated Clearing House
AFP	Advanced Format for Printing
ASCII	American Standard Code for Information Exchange
CORBA	Common Object Request Broker Architecture
EBCDIC	Extended Binary Coded Decimal Interchange Code
HTML	Hypertext Markup Language
HTTP	Hypertext Transport Protocol
IIOP	Internet Inter-ORB Protocol
JDBC	JAVA Database Connectivity
MRDF	Mail Run Data File

ORB	Object Request Broker
PDF	Portable Document Format
SMTP	Simple Mail Transfer Protocol
XML	Extended Markup Language

Table 2

Parameter	Length	Offset	Description
EMRDFID	10	0	Identifier for this job
PrtStrmID	20	10	Identifies which print stream, most likely a file, that goes with this EMRDF. For a file, 8-dot-3 naming convention is acceptable. The directory in which the file resides is a job setup parameter.
TotalPieces	8	30	Total number of piece records. 10M max.
RecEnd	2	38	CRLF pair; hex 0D0A
The header record contains exactly 40 bytes.			

Table 3

Parameter	Length	Offset	Description
PieceNumber	8	40	Piece number, Unique to file.
AccountNumber	20	48	Customer's account number for billing.
PaperFlag	1	68	Y or N indicating whether paper was sent also.

TemplateID	5	69	Template for document composition.
Insert01	1	74	Y or N indicating whether to include this insert.
Insert02	1	75	Y or N indicating whether to include this insert.
Insert03	1	76	Y or N indicating whether to include this insert.
Insert04	1	77	Y or N indicating whether to include this insert.
Insert05	1	78	Y or N indicating whether to include this insert.
Insert06	1	79	Y or N indicating whether to include this insert.
Insert07	1	80	Y or N indicating whether to include this insert.
Insert08	1	81	Y or N indicating whether to include this insert.
Insert09	1	82	Y or N indicating whether to include this insert.
Insert10	1	83	Y or N indicating whether to include this insert.
Insert11	1	84	Y or N indicating whether to include this insert.
Insert12	1	85	Y or N indicating whether to include this insert.

Insert13	1	86	Y or N indicating whether to include this insert.
Insert14	1	87	Y or N indicating whether to include this insert.
Insert15	1	88	Y or N indicating whether to include this insert.
Insert16	1	89	Y or N indicating whether to include this insert.
InsertPriority01	2	90	Priority of this insert. 1 to 16
InsertPriority02	2	92	Priority of this insert. 1 to 16
InsertPriority03	2	94	Priority of this insert. 1 to 16
InsertPriority04	2	96	Priority of this insert. 1 to 16
InsertPriority05	2	98	Priority of this insert. 1 to 16
InsertPriority06	2	100	Priority of this insert. 1 to 16
InsertPriority07	2	102	Priority of this insert. 1 to 16
InsertPriority08	2	104	Priority of this insert. 1 to 16
InsertPriority09	2	106	Priority of this insert. 1 to 16
InsertPriority10	2	108	Priority of this insert. 1 to 16
InsertPriority11	2	110	Priority of this insert. 1 to 16
InsertPriority12	2	112	Priority of this insert. 1 to 16
InsertPriority13	2	114	Priority of this insert. 1 to 16
InsertPriority14	2	116	Priority of this insert. 1 to 16
InsertPriority15	2	118	Priority of this insert. 1 to 16
InsertPriority16	2	1120	Priority of this insert. 1 to 16

RecEnd	2	122	CRLF pair; hex 0D0A
The piece record contains exactly 124 bytes. There can be up to 10 million piece records in a file.			

Table 4

MODULE	FUNCTION
Enrollment Application Module 27	Capture customer account number, full name of customer, email address of customer, checking account number, customer's account bank name, bank routing number, WEB password
Print Stream Separator 16	Based on customer account number, split out documents destined by digital delivery, send these documents as AFP file.
Electronic Inserter 26	Get data from Job Setup Module 32, customer preference file from customer preference database 20, print stream separator 16 and EMRDF output, compose bill request objects (bR), receive status messages from RIP, control AFP feed to IBPS.
Job Setup Application 32	Produce file of inserts in the form of hotlinks that are logically assigned to physical inserter bins.

Router Instruction Processor (RIP) 36	Service incoming requests from multiple clients (EIs), route requests to FAX, EMAIL, WEB, LOCAL PRINT, and PAGER, issue notifications based on status received, process status back to clients.
Database Account 56	Store remittance data, bill data, and status data for digital bills.
Bill Processing Server (BPS) 42	Save and retrieve bill data to the database, service CORBA requests for hotlinks from IBPS, process bill status messages from IBPS back to the RIP, issue reports and initiate payments feeds.
Interactive Bill Present Server (IBPS) 44	Process interactive events performed on the bill by customers, render HTML to customers based on downloaded servlets and stored XML rules, design document templates.

What is claimed is:

1. An apparatus for separating print stream data containing a plurality of primary documents and information concerning associated customers for receipt of each primary document, said print stream data to be separated into at least two data paths by said apparatus, one path of which is for electronic delivery of an electronic primary document with N secondary documents inserts, where N is a non-negative integer including 0, said apparatus comprising a print stream separator having:
 - A) means for receipt of the print stream data and means for receipt of customer preference data regarding at least some of the customers to which said print stream is directed;
 - B) means based upon the customer preference data for determining if a particular primary document in the print stream is intended for electronic delivery to the associated customer and if so, generate an output of the print stream for electronic delivery thereof; and
 - C) means for generating an output for the remaining print stream data for non-electronic delivery thereof;wherein the means for determining if a particular primary document is intended for electronic delivery further has means for generating a second output related to the control and preferences of any secondary documents to be associated with the primary document, the second output containing information regarding which secondary documents can accompany the primary document and respective priorities of the secondary documents that can accompany the primary document.
2. An apparatus for separating print stream data as defined in Claim 1, further comprising an electronic inserter for receipt of the print stream for electronic delivery and for receiving the second output related to the preferences of the associated customer, for generating an electronic

print stream output containing the primary document associated with the customer, as well as information with respect to each secondary document to be associated with the primary document based upon the customer preference data.

3. An apparatus for separating print stream data as defined in Claim 2, wherein the electronic inserter further has means for receipt of job setup data which contains information concerning links directed to secondary documents that can be associated with a primary document

for delivery to a particular customer electronically.

4. An apparatus for separating print stream data as defined in Claim 3, wherein the electronic inserter further comprises means for generating control and status data concerning the electronic print stream output generated by the electronic inserter.
5. An apparatus for separating print stream data as defined in Claim 4, further wherein the electronic inserter receives customer preference data from a customer preference database and wherein said information is used to assist in notifying customers that at least a primary document is available for viewing.
6. An apparatus for separating print stream data as defined in Claim 5, further comprising means for modifying the customer preference data contained in the customer preference database.
7. An apparatus for separating print stream data as defined in Claim 6, wherein the apparatus for modifying the customer preference data contained in the customer preference database operates via the Internet with the customer.
8. An apparatus for separating print stream data as defined in Claim 5, wherein the received customer preference data by the electronic inserter can be used to determine the specific way the customer is notified that at least a primary document is available for viewing.
9. An apparatus for separating print stream data as defined in Claim 8, wherein the customer may be notified in more than one way that at least a primary document is available for viewing, and wherein an alternative way of notifying the customer is used if the customer does not view at least the primary document within a predetermined time after initial notification.

10. An apparatus for separating print stream data as defined in Claim 2, wherein the electronic print stream output of the electronic inserter is in the AFP file format.
11. An apparatus for separating print stream data as defined in Claim 1, wherein the means for determining if a particular primary document is intended for electronic delivery further has means for generating a second output related to the control and preferences of any secondary documents to be associated with the primary document.
12. An apparatus for separating print stream data as defined in Claim 11, wherein the second output of the print stream separator contains information regarding which secondary documents can accompany the primary document.
13. An apparatus for separating print stream data as defined in Claim 12, wherein the second output of the print stream separator contains information regarding the priorities of the respective secondary documents that can accompany the primary document.
14. An apparatus for separating print stream data as defined in Claim 1, wherein the priorities of at least one secondary document is based at least in part on customer preference data for the customer to receive said primary document.
15. An apparatus for separating print stream data as defined in Claim 1, wherein the inclusion or exclusion of at least one secondary document is based upon customer preference data.
16. A method for separating print stream data containing a plurality of primary documents and information concerning associated customers for receipt of each primary document, said print stream data to be

separated into at least two data paths, one path of which is for electronic delivery of an electronic primary document with N secondary documents inserts, where N is a non-negative integer including 0, said method comprising the steps of:

- A) receiving the print stream data and receiving the customer preference data regarding at least some of the customers to which said print stream is directed;
 - B) based upon the customer preference data, determining if a particular primary document in the print stream is intended for electronic delivery to the associated customer and if so, generating an output of the print stream for electronic delivery thereof;
 - C) generating an output for the remaining print stream data for non-electronic delivery thereof; and
 - D) for the print stream intended for electronic delivery, prioritizing any secondary documents that are to be sent to the customer, such that some secondary documents are given higher priority for inclusion or positioning than other secondary documents.
17. A method as defined in Claim 16, further comprising the step of notifying the customer that at least a primary document is available for viewing.
18. A method as defined in Claim 17, further comprising the step of generating information regarding the priorities of any secondary documents that are to be sent to the customer.
19. A method as defined in Claim 18, wherein the priority of at least one of the secondary documents is based at least in part on customer preference data for the customer to receive the primary document.

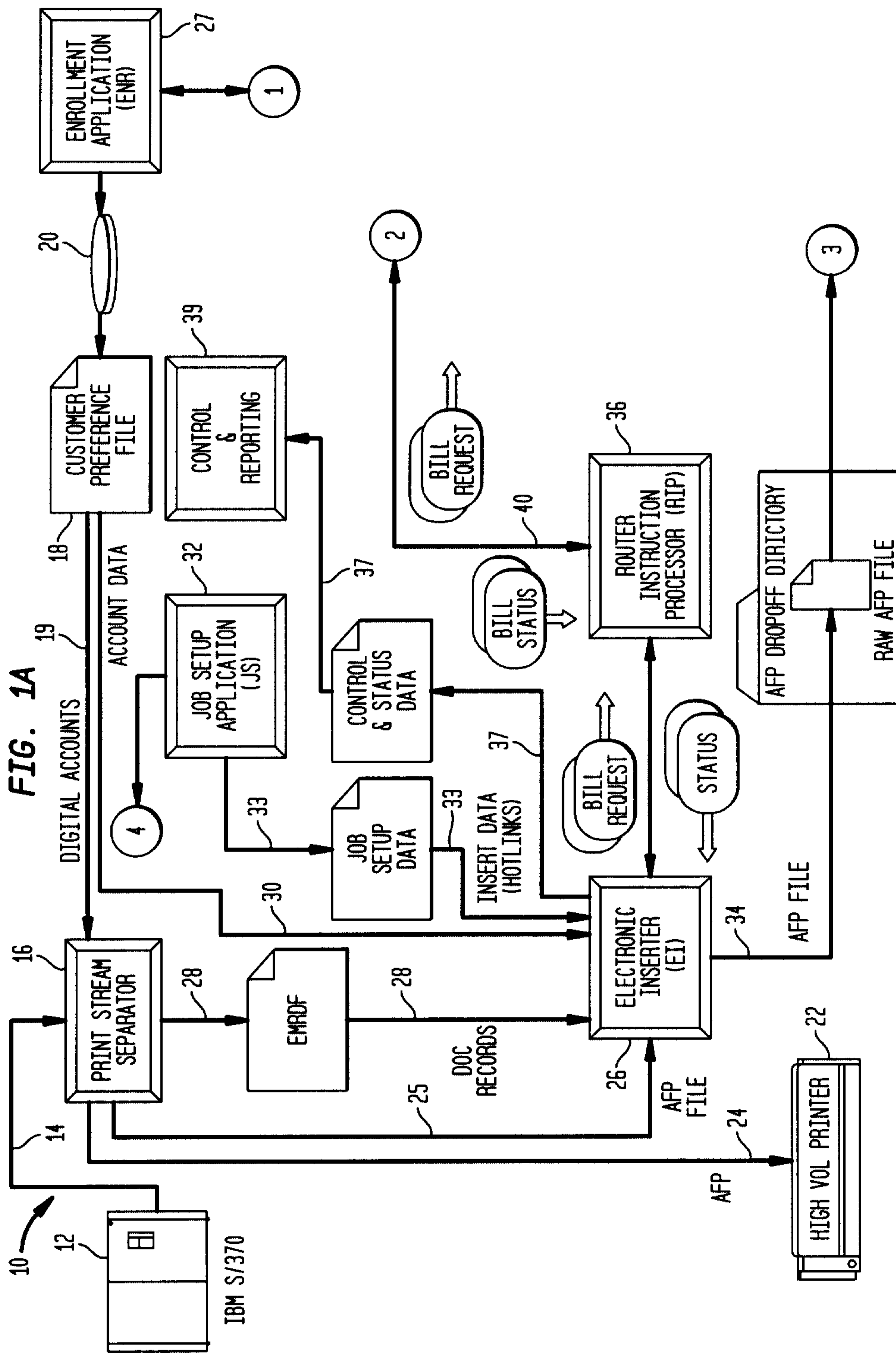

FIG. 1B

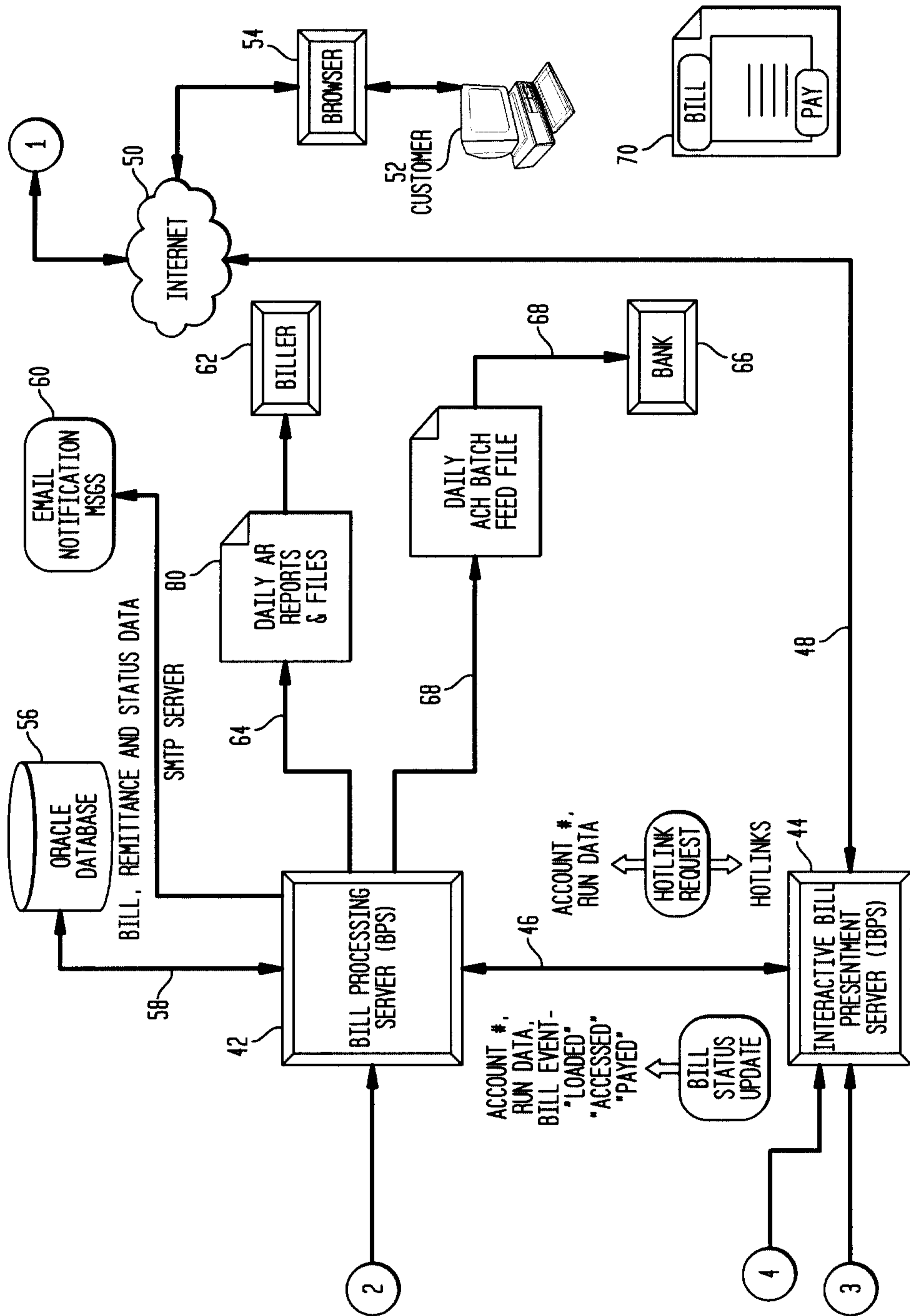

FIG. 2

