

B.C. Lawson,

Washing Machine.

No. 110,478.

Patented Dec. 27, 1870.

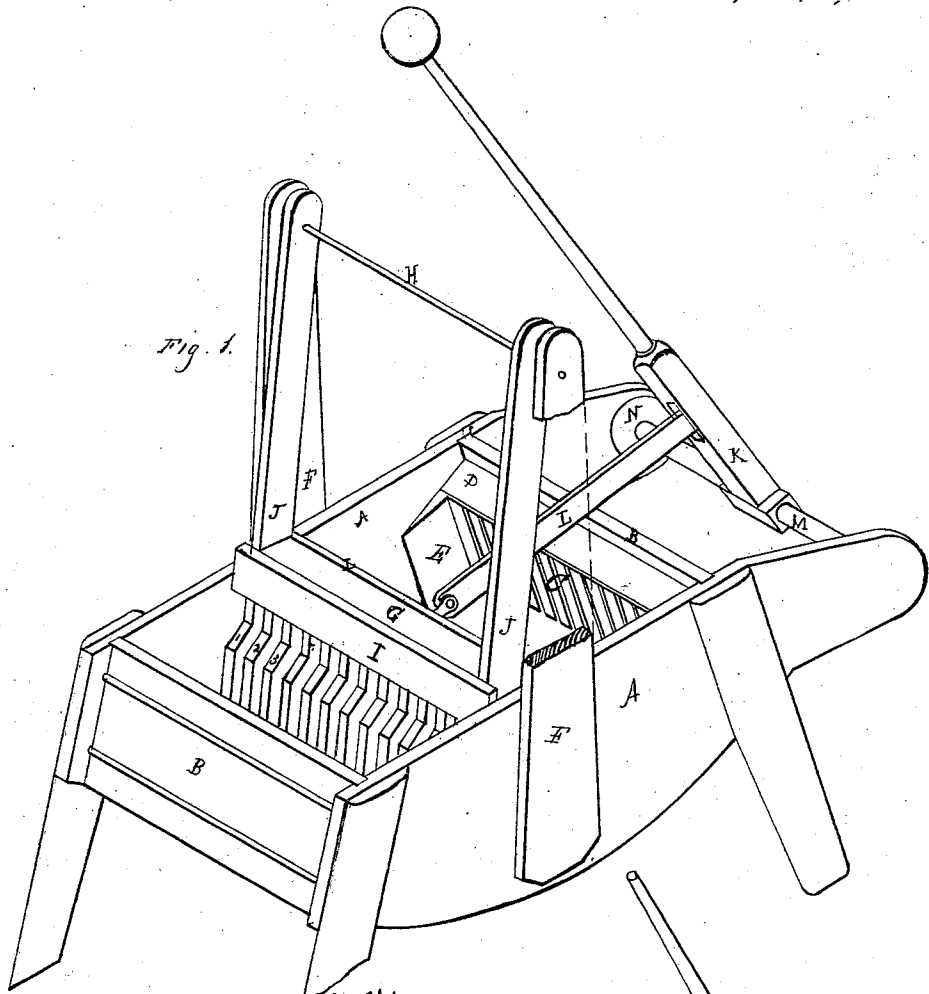

Fig. 1.

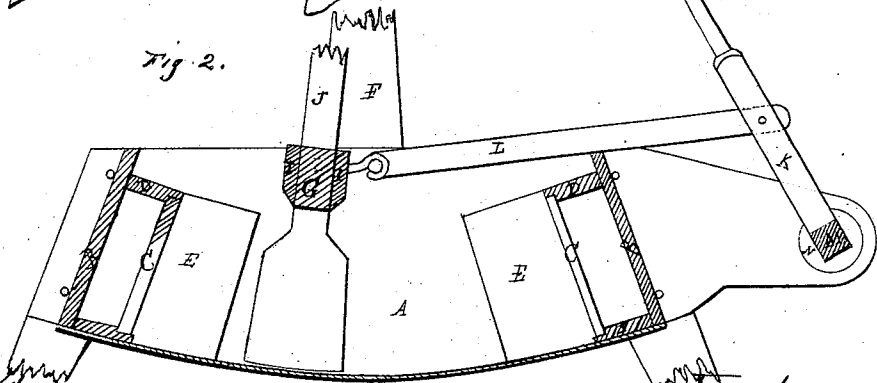

Fig. 2.

Witnesses.

*Edmund R. Bush
E. L. Hall*

Inventor.

B. C. Lawson

United States Patent Office.

BALAAM CHAFFIN LAWSON, OF YOLO COUNTY, CALIFORNIA.

Letters Patent No. 110,478, dated December 27, 1870.

IMPROVEMENT IN WASHING-MACHINES.

The Schedule referred to in these Letters Patent and making part of the same.

To all to whom it may concern:

Be it known that I, BALAAM CHAFFIN LAWSON, of the county of Yolo and State of California, have invented a new and useful Washing-Machine for washing clothes and other fabrics of linen, cotton, wool, or other fabrics; and I do hereby declare that the following is a full, clear, and exact description of the construction and operation of the same, reference being had to the annexed drawing making a part of this specification, in which—

Figure 1 is a perspective view, and
Figure 2 is longitudinal section.

The said machine consists of the following parts, to wit:

First. Of a tub or box, the sides A A being parallel, the top edges of said sides being straight, the bottom the arc of a circle, corresponding very nearly to that described by the swing or vibration of the dasher or plunger G, as seen in the drawing, and hereinafter described. The said sides extend beyond one of the ends B B of the tub, for the purpose of holding the lever-axle M.

Second. The ends B B form right angles with the sides A A, and incline inward from bottom to top sufficiently to accomplish the result hereinafter specified.

Third. The bottom of said tub is made of galvanized sheet-iron, and secured by nails or otherwise.

Fourth. At each end, and on the inside thereof, is placed and secured a wash-board or rack, C C, of the full width of said tub. Said wash-board or rack is composed of slats reaching from the bottom to near the top of said ends B B, with spaces between said slats of half the width of the face of said slats, or thereabout, or at such distance apart as will effect the result hereinafter named. The said slats are held in position by the caps or pieces D D, placed and secured upon each end of said slats. Said caps D D, being all of same width, and resting their outward edges against the ends B B of tub, give the same angle to wash-board as that of the ends B B. The edges inward of the caps D D are on a line with the face or inside edge of the slats composing wash-board or rack, and, said caps being wider than the slats, leave a space between said slats or wash-board and the ends B B of the tub, for the purpose hereinafter described.

Fifth. On each side of said tub, and on the inside thereof, and at both ends, are affixed the beveled boards E E, said boards being of equal length of slats composing wash-boards, and placed with the thick edges against said wash-boards and the thin edges toward center of tub, as seen in drawing, said boards to be of a thickness, width, and slope to effect the result hereinafter named.

Sixth. On each side, and on the outside of said tub,

are attached two uprights, F F, for the purpose of swinging the dasher G.

Seventh. The dasher or plunger G is composed of a number of pieces or feet, 1, 2, 3, &c., made of boards an inch thick, more or less, with shanks of sufficient length to be secured or fastened above the surface of the water in the tub. The said pieces or feet 1, 2, 3, &c., are held in position by placing pieces of boards of about the same thickness of the said feet of dasher, and of the same width with the shanks of said feet, and length to correspond with the width of pieces I I, between the upper ends of the shanks of said feet, and securing the same by the pieces I I, which said pieces I I are drawn together by bolts and screws. The said dasher G is swung by the shanks J J of the two outside feet (made of sufficient length for that purpose) upon an iron rod, H, which said rod passes through said shanks near the top, and through and near the top of the uprights F F.

Eighth. The said dasher is operated by the lever K, being connected therewith by the pitman L. The said lever K is also connected with the axle M, which said axle is placed in the buttons N N, secured to inside ends of said extended sides before mentioned. On the top of said lever K is placed a cast-iron ball, to give force to the stroke of the dasher.

Ninth. Said machine is set on four legs, with upper ends leaning inward at top at same angle of ends of tub.

Tenth. The construction and operation of the machine, the parts of which have been described, are as follows, to wit:

The tub is an oblong of sufficient capacity to give proper play to the dasher and contain as many clothes or other fabrics as may be successfully handled, say six sheets, or equivalent, more or less. The clothes are put into the tub, in equal parcels, in each end, or on each side of the dasher, with water sufficient to nearly cover the parcels to be washed after the same have been wet and pressed together in a roll reaching across the full width of the tub.

When the machine is operated, the parcels of fabric or clothes are driven, first one and then the other, against the wash-boards or racks placed respectively in each end of the tub, as before stated.

The dasher G, as hereinbefore described, may be passed briskly through the water without any perceptible resistance therefrom, leaving the almost entire force of the stroke to operate on the parcels to be washed. The water, being thus forcibly and suddenly pressed from the clothes or other fabrics, escapes partly back between the feet of the dasher, and partly through the wash-board or rack, into the space left for that purpose between said wash-boards on the

outer ends of said tub. The water is thereby prevented from being thrown over the top of the tub.

The water, by the operation of the said dasher G, is driven rapidly through the fabric, successfully and rapidly removing the particles of dirt.

At every stroke of the dasher the fabric or parcel in the tub makes one-fourth of a revolution, being effected by the combination of the circular bottom, the inward inclination from bottom to top of the wash-board, the beveled boards upon the sides, and the returning weight of the water thrown or forced by the stroke of the dasher into the space between the wash-board and the end of the tub, the water at the termination of the stroke in said space being much above the common level of the water in the tub.

When the parcel of fabric is forced against the wash-board by the stroke of the dasher said parcel is flattened and stands on edge, and, by the combination hereinbefore stated, falls forward, with the edge toward the dasher—the best possible position to receive the next stroke.

The purpose of the beveled boards E E is to make the side of the parcel of the clothes, when driven

against the wash-board, shortest next the wash-board, so that, in falling forward, the parcel is relieved from pressure against the sides of the tub.

Clothes turned in the manner described do not pack or twist together as they do when turned gradually or by degrees.

The edges of the feet 1, 2, 3, &c., of the dasher G slope back from bottom to top, to correspond with the face of wash-board or rack.

I do not claim as my invention any part of said machine except those hereinafter enumerated, to wit:

What I claim as my invention, and desire to secure by Letters Patent, is—

The combination of the circular bottom, the dasher G, the inclining wash-boards or racks C C, and the converging sides or beveled boards E E, in combination with axle M, pitman L, and weighted lever K, as constructed and shown, as the same is set forth in the foregoing specifications.

BALAAM CHAFFIN LAWSON.

Witnesses:

EDWIN R. BUSH,
E. G. HALL.